

Schwarze Industries, Inc.



A7 TORNADO

Product Manual



Quality	Performance	Public Safety	Value	Customer Support

BROUGHT TO YOU BY
Bortek
WE KNOW CLEAN[®]

A MEMBER OF THE
ALAMO GROUP
ALWAYS ON THE CUTTING EDGE[™]

© Schwarze Industries

Schwarze Industries, Inc.

A7

TORNADO

Product Manual



Foreword



Dear customer,

We are pleased to have you as a Schwarze customer. Your new sweeper has been carefully designed to give maximum service with minimum downtime.

This manual is provided to give you the necessary operating and maintenance instructions for keeping your sweeper in top operating condition. Careful use and timely service save extensive repairs and costly downtime losses. Make sure to read this manual thoroughly and understand what each control is for and how to use it.

Safety is of primary importance to the owner/operator and the manufacturer. Observe all safety precautions decals on the machine and noted throughout the manual for safe operation. If any assistance or additional information is needed, contact your authorized Schwarze dealer.

In addition to having many Authorized Dealers located throughout the country, Schwarze Industries also maintains a fully stocked factory service center in Huntsville, Alabama. In the event you need parts or service, call your nearest Authorized Dealer. Their name and number can be found on the Sweeper Information Sheet, located in the front of this manual. In the unlikely event that your local dealer is unable to provide the assistance you require, call us at our home office in Huntsville, Alabama. We have a state-of-the-art fabrication and production facility and a complete service and refurbishing center with an inventory of over \$500,000 in spare parts. In most cases, same day shipping and overnight delivery are available.

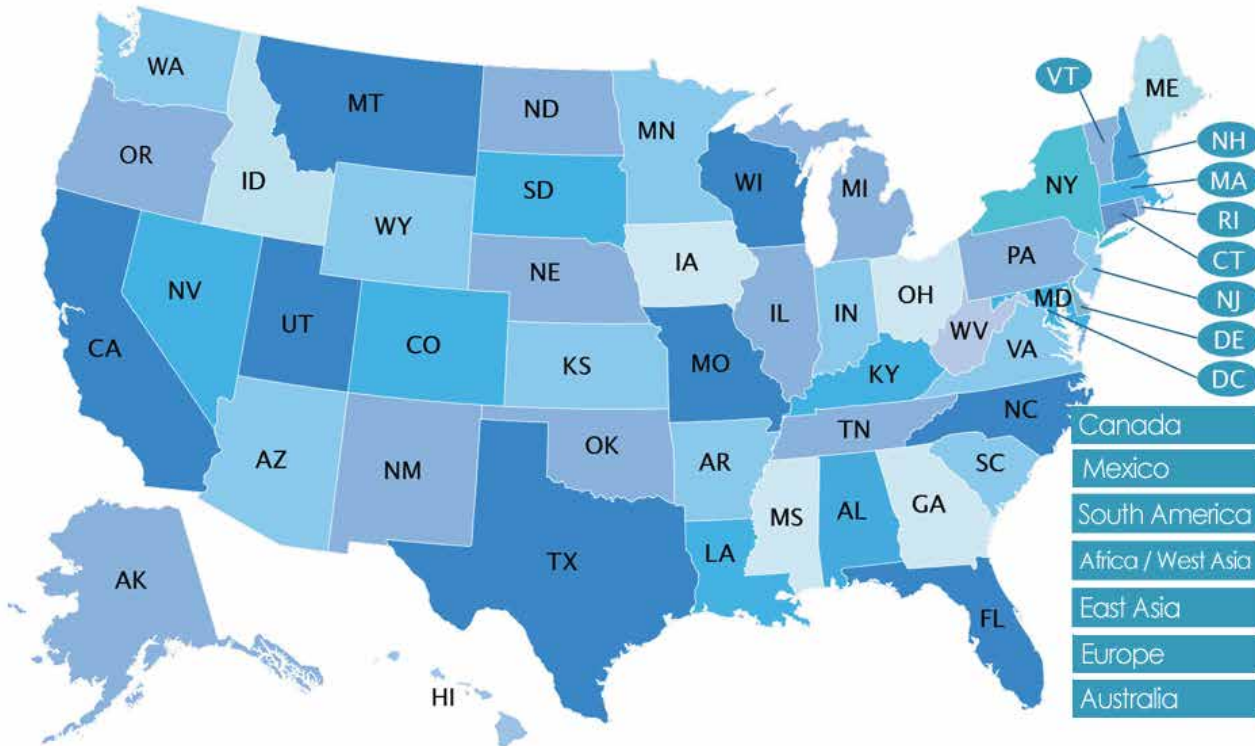

Schwarze dealer locator: <http://www.schwarze.com/locator>

Schwarze website: <http://www.schwarze.com>

Schwarze Customer Service: 1.800.879.7934

In This Manual

Foreword	4
1 Safety	9
General Safety Instructions and Practices	10
Visual Attention Safety	11
Personal Protection Equipment (PPE)	12
When Using Pressurized Air or Water	13
General Hazards and Prevention Safety	14
Entanglement and Entrapment Hazards De-energize Procedures	16
Vacuum Blockage Removal Hazards	17
Crushing Hazards and Prevention Safety	18
Trip and Fall Prevention Safety	19
High-pressure Fluid Leak Hazards	20
Power Lines/Static Electrical Hazard Warnings	21
Chemical and Biological Hazard Safety	22
Transport Safety and Hazards Warnings	23
Back Over Run-over Hazards	25
Sweeper & Vacuum Equipment Hazard Warnings	26
Thrown Object Hazards	27
Vacuum Equipment Operation Safety and Hazard Warnings	28
Dust Hazard and Explosion Prevention Safety	31
Operator Safety	32
Fire Hazards	33
Debris Body Dumping Safety and Hazard Warnings	34
Confined Space Hazard Warnings	35
De-energize and Lockout Procedures	36
Hazards with Equipment Maintenance	37
Hazard with Maintenance of Sweeper	38
1.14 Safety Decals Locations	41
2 Technical Data	47
3 Pre-Operation	49
Pre-Operation Inspection	50
Side Broom Pattern Check	52
4 Operations	53
4.1 The Sweeping Control Console	54
4.2 Water Switches	54
Dust Suppression System Operation	54
High Pressure Washdown (if equipped)	55
4.3 Lighting Switches	55
4.4 Regenerative Air Switches	55
Pickup Head Operation	55
Bleeder Door Operation	56

Sweeper Standby	56
4.5 Side Broom Switches	57
Side Broom Operation	57
Side Broom Speed	57
Side Broom Extension Override (if equipped)	58
Side Broom Tilt (if equipped)	58
Side Broom To Pavement Contact (Down Pressure) (if equipped)	58
4.6 Additional Optional Switches	59
Magnet Bar (if equipped)	59
Self Dumping Magnet (if equipped)	59
Driver Position (if equipped)	59
4.7 The Hopper Control Joystick	60
Main Indicator Area	61
Auxiliary Engine Speed Controls	61
Sweeps-In-Reverse Selection	61
4.9 Auxiliary Engine Start-up	61
4.10 Camera System	62
Hand Hose (if equipped)	63
Hopper Drain (if equipped)	64
Hopper Deluge (if equipped)	64
4.12 End of Shift Cleanup and Maintenance	64
5 Troubleshooting	67
5.1 Troubleshooting the Sweeping System	68
5.2 Troubleshooting the Auxiliary Engine	69
5.3 Troubleshooting the Water System	69
5.4 Troubleshooting the Hydraulic System	70
5.5 Troubleshooting the Side Brooms	71
5.6 Troubleshooting the Camera System	72
5.7 Troubleshooting the Automatic Shutdown System	72
6 Service	73
6.1 Oil Levels and Lubrication	74
Auxiliary Engine Oil	74
Auxiliary Engine Cooling System	74
Hydraulic System	74
Lubrication Schedule	74
Fan Shaft Bearing Lubrication	74
6.2 Pickup Head	75
Replacing the Skid Plate	75
Adjusting the Pickup Head Tension Spring	75
Replacing the Pickup Head	76
Replacing the Pickup Head Flaps	76
Adjusting the Pickup Head Blast Orifice	76
Replacing the Pickup Head Hoses	77
6.3 Hopper	77

Replacing the Hopper Seals	77
Replacing the Hopper	78
6.4 Side Broom(s)	78
Adjusting the Manual Side Broom Tilt	78
Adjusting the Manual Side Broom To Pavement Contact/Down-Pressure	79
Adjusting the Side Broom Extension Spring	80
Adjusting the Side Broom Hydraulics	80
Adjusting/Replacing the Side Broom Cylinder	81
Replacing the Side Broom Motor	81
Replacing the Side Broom Tilt Cylinder	82
Replacing the Side Broom Bristles	82
6.5 Power Module	83
Replacing the Engine Stub Shaft	83
Adjusting the Drive Belt Tension	84
Replacing the Drive Belt	84
Inspecting the Sweeping Fan System	85
Replacing the Fan System Fan	85
Replacing the Fan House Liner	87
Replacing the Fan Shaft Bearing	87
Hydraulic System Service Schedule	88
Hydraulic Tank	88
Adjusting the Hydraulic System Pressure	89
Checking the Directional Valve Override	89
6.6 Dust Suppression System	90
Refilling the Water Tank	90
Cleaning the Water Manifold Solenoid	90
Cleaning/Replacing the 'Y' Strainer	91
Water Pump Pressure Check	92
Water Nozzle Cleaning/Replacement	92
Dust Suppression System Winterizing	92
6.7 Electrical System	93
Fuse Panel Layout	93
Display Panel Descriptions	93
Operator's Screen	93
Menu Controls	93
Emission Control Catalyst Cleaning (Regen) , Engine Fault Codes and Other Engine Data	94
Cleaning the Catalyst	95
Maintenance and additional Screens	95
Resetting Equipment Hour Meters	96
The Engine Trouble Codes screen	96
Catalyst Condition / Soot Levels	97

Section 1 - Safety



GENERAL SAFETY INSTRUCTIONS AND PRACTICES

A careful operator is the best operator. Safety is of primary importance to the manufacturer and should be to the owner/operator. Most accidents can be avoided by being aware of your equipment, your surroundings, and observing certain precautions. The first section of this manual includes a list of Safety Messages that, if followed, will help protect the operator and bystanders from injury or death. Read and understand these safety messages before assembling, operating, or servicing this equipment. This equipment should only be operated by those persons who have read the manual, who are responsible and trained, and who know how to do so responsibly.



The Safety Alert Symbol combined with a Signal Word, as seen below, is used throughout this manual and on decals which are attached to the equipment. The Safety Alert Symbol means: **“ATTENTION! BECOME ALERT! YOUR SAFETY IS INVOLVED!”** The Symbol and Signal Word are intended to warn the owner/operator of impending hazards and the degree of possible injury faced when operating this equipment.

Practice all usual and customary safe working precautions and above all remember safety is up to **you**. Only **you** can prevent serious injury or death from unsafe practices.



DANGER

Indicates an imminently hazardous situation which, if not avoided, **WILL** result in death or serious injury.



WARNING

Indicates a potentially hazardous situation which, if not avoided, **COULD** result in death or serious injury.



CAUTION

Indicates a potentially hazardous situation which, if not avoided, **MAY** result in minor or moderate injury and property damage. It may also be used to alert against unsafe practices.

NOTICE

Indicates a potentially hazardous situation which, if not avoided, **MAY** result in property damage. It may also be used to alert against unsafe practices.

NOTE

Identifies points of particular interest for more efficient and convenient operation or repair.



READ, UNDERSTAND, and FOLLOW the following **Safety Messages**.

Serious injury or death may occur unless care is taken to follow the warnings and instructions stated in this manual and in the Safety Messages on the equipment. Always follow the instruction in this manual and use common sense to avoid hazards.

VISUAL ATTENTION SAFETY

Pictographs are used throughout this manual to help bring your visual attention to safety issues.

SAFETY HAZARD	SAFETY AVOIDANCE	SAFETY PREVENTION
<p>Pictograph surrounded by a triangle indicates a Safety Hazard that must be avoided. <i>Example:</i></p>  <p>Equipment contacting overhead electrical lines</p>	<p>Pictograph by itself or inside a box indicates an avoidance procedure that should be followed to prevent injuries. <i>Example:</i></p>  <p>Always shut off engine and remove key before working on equipment.</p>	<p>A circle with a slash through it indicates an action that is prohibited. <i>Example:</i></p>  <p>No Smoking</p>

Figure 1-1

NOTE

If you want a translation of this safety section in Spanish or French, please contact:

***Translation — Safety Section
(Company Contact Information)***

PERSONAL PROTECTION EQUIPMENT (PPE)

Wear Safety Glasses	Wear Hard Hat	Wear Safety Shoes	Wear Hearing Protection	Wear Protective Gloves	Wear Safety Reflective Vest

Figure 1-2

Always wear protective clothing and personal safety devices issued to you or required by job conditions. This should always include:

- Hard hat
- Safety shoes
- Safety glasses, goggles, or face shield
- Heavy gloves (chemical resistant)
- Hearing protection
- Reflective clothing

WARNING
<p>Never wear loose clothing or jewelry that can catch on controls or other parts of the machine. Loose clothing can be drawn into the suction hose or rotating components. Never wear a wristwatch or finger rings when working on or around equipment.</p>

WHEN USING PRESSURIZED AIR OR WATER





			
<p>Wear Face Protection Shield</p>	<p>Wear Protective Suit</p>	<p>Wear Waterproof Gloves and Safety Shoes</p>	<p>Wear Respirator</p>

Figure 1-3

When using pressurized air or water for cleaning you should use the following:

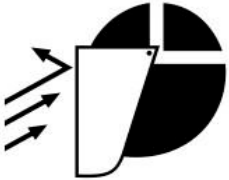
- Face Shield
- Wet Weather Protective Suit
- Waterproof Gloves
- Respirator
- Safety Boots with Metatarsal Guard

GENERAL HAZARDS AND PREVENTION SAFETY

Read and Understand Operator's Manual	DO NOT USE DRUGS or ALCOHOL before or while operating equipment	Always shut off engine and remove key before working on equipment	Always install Debris Body and debris door props before working under equipment	Always wear your seatbelt

Figure 1-4

WARNING

To avoid serious injury or death, do the following:

- Read, understand, and follow the operator's manual instructions, warnings, and safety messages.
- Do not allow untrained or unauthorized persons to operate equipment.
- Do not allow untrained coworkers to operate or assist in operating equipment.
- Do not allow bystanders near equipment or work area.
- Do not allow anyone to operate equipment while under the influence of drugs or alcohol.
- Consult medical professional for medication impairment side effects.
- Wear appropriate safety personal protective equipment (PPE).
- Wear appropriate breathing respirator and protective suit when operating with hazardous or unknown substances.
- Do not wear loose clothing or jewelry to avoid injury from entanglement in rotating parts.
- Keep body and limbs away from suction inlets.
- Do not open or close the debris door or raise or lower the body unless the area is clear of people and obstructions.
- Never put any part of your body under an open debris door unless it is sufficiently supported by prop.
- Never operate the vacuum pump unless you are certain the suction hose is clear of people and obstructions.
- Do not enter the debris body if hazardous materials are suspected inside the debris body. Take the unit to a certified tank cleaning facility.

- **Always shut off the engine**, remove the key, and set the parking brake before working on the truck or equipment.
- Stay alert. Prolonged operation can cause fatigue. Stop and rest.

Keep away from ROTATING ELEMENTS like gutter brooms and sweeping head.

- Do not operate sweeper if excessive vibration or noise exists.
- Never operate the sweeper if it becomes entangled with wire, rope, cable or chain. These items can cause mechanical damage or injure the operator or passerby.
- Keep away from suction elements such as suction head and suction hoses to prevent from being drawn into sweeper head, this could cause serious injury or death.

GROUND SPEED WHEN SWEEPING:

- Normal Speed range is 1 to 5 mph for curb line and 0 - 15 mph in open lot.
- DO NOT exceed rated operating speed for Truck and Auxiliary Engine.
- Never Sweep debris that is too large for sweeper to pick up.
- Use Right side steering for sweeping, and never while exceeding 15 mph. Sweeper must be driven from left side unless sweeper is only equipped with right side steering and controls.
- REDUCE sweeping SPEED when near steep slopes, ditches, drop-offs, overhead obstructions, and power lines.
- Stop sweeping if anyone comes within 25 feet of sweeper.
- Sweeper brooms are capable of propelling objects up to 25 feet

GENERAL HAZARDS AND PREVENTION SAFETY — CONTINUED





			
<p>Use adequate lighting for proper vision</p>	<p>Do not touch hot surface. Keep hands and limbs away from hot surfaces</p>	<p>Tanks can be under pressure. Relieve pressure before opening</p>	<p>Use three-point contact when climbing on equipment</p>

Figure 1-5

Visibility Conditions When Operating

- **Operate in daylight** or with lights that give at least 50 yards clear visibility.
- **Be able to see** and identify passersby, steep slopes, ditches, drop-offs, overhead obstructions, power lines, debris, and foreign objects.
- **Use extreme care** when backing up. Vision may be limited. Severe damage or injury can occur.
- **Do not run engines** in enclosed building without adequate exhaust ventilation.

Safety Signs

- **Replace** missing, damaged, or unreadable safety signs immediately!

Equipment Guards

- Do NOT operate machine if equipment guards are damaged or missing.
- **Replace** missing or damaged guards immediately!

Mounting and Dismounting Truck or Equipment

- **Only** mount or dismount when truck and moving parts are stopped.
- Never jump when exiting the machine. Never mount or dismount a moving machine.
- **Always use three-point contact** when climbing on or dismounting equipment.
- **Walkways, steps, and handrails** should be checked before use to ensure a proper non-slip surface. Replace or repair damaged components immediately.
- Use Steps Hand holds correctly
- Prevent falls by facing the machine when getting on and off. Maintain 3-point contact with steps, handholds, and hand rails.
- Use extra care when mud, snow or moisture present slippery conditions. Keep steps clean and free of grease and mud.
- Walkways, steps, and handrails should be checked before use to ensure a proper non-slip surface.
- Replace or repair damaged component immediately.

Hot Surface

- Stay clear of hot surfaces such as mufflers, hydraulic pumps, valves, and tanks.
- Relieve pressure from tank, reservoirs, valves, and hoses before servicing or opening.

ENTANGLEMENT AND ENTRAPMENT HAZARDS DE-ENERGIZE PROCEDURES

Brush or Convey Entanglement Hazard	Crushing Hazard	Remove key and read service/maintenance manual/handbook before servicing	Wait until all moving parts have stopped completely	Lock-Out

WARNING

Before attempting to remove a system blockage **ALWAYS SHUT DOWN ALL ENGINES AND DE-ENERGIZE THE MACHINE.** Serious injury or death can result from entanglement from reaching in or under moving or lifted components of the machine.

WARNING

Before loosening or removing hydraulic hoses or fittings **ALWAYS SHUT DOWN ALL ENGINES AND DE-ENERGIZE THE MACHINE.** Serious Injury or Death can result from falling boom, debris hopper, conveyor or raised components

- Lock the truck doors and securely store the truck keys.
- Securely install transport locks and block up any raised components to prevent inadvertent movement or falling.

DANGER





KEEP AWAY FROM ROTATING BLADES, BELTS AND PULLEYS TO AVOID SERIOUS INJURY OR DEATH FROM BLADE CONTACT:

- STAY AWAY and KEEP HANDS, FEET and BODY AWAY from rotating blades and parts until all moving elements have stopped.
- DO NOT put hands or feet under sweeper shielding.
- STOP rotating FAN BLADES disengage power and wait for blade to stop rotating before adjusting shields or components.
- STOP LOOK and LISTEN before approaching the sweeper to make sure all rotating motion has stopped.

To properly de-energize this equipment:

- Lower the debris body and debris door to the lowered transport position or onto the mechanical props to support the component.
- Lower the boom (if equipped) to the storage position or to the lowest or ground position.
- Place the transmission in the park position or neutral if not equipped with park position.
- Set the parking brake.
- Turn off the engine and remove the keys.
- Switch the battery power off if the truck has a battery disconnect switch, or disconnect the battery ground cables.

VACUUM BLOCKAGE REMOVAL HAZARDS

				
Never go under raised Debris Body until Prop is installed	Install Body Prop	Do not reach into vacuum hoses or tubes	Do not reach into fan or fan housing	Shut off Engine and wait until all motion has stopped

! DANGER

Removing blockage for the vacuum suction line can be extremely dangerous and result in serious bodily injury or death. Never attempt to clear the blockage unless the body props are in place and the engine(s) are shut off.

- Start sweeper vacuum system and make sure blockage has been cleared.
- If blockage remains take the unit to a service center to have the blockage removed.

! DANGER

Never attempt to clear the blockage unless the body props are in place and the engine(s) are shut off.

Before attempting to remove blockage:

- Engage the truck parking brake
- Raise the debris body and install debris body and install hopper chock
- Raise the vacuum head chock
- Raise the vacuum head off the ground and securely block it up to prevent it from falling
- Shut off the truck engine and any auxiliary engines, and wait for all motion to stop.

Never use hands or arms to reach under or into equipment to remove blockage

- Never place your hand or arms underneath the vacuum head. Use a reach tool to remove any debris blockage from under the Vacuum head:
- Only use a reach tool to remove blockage from vacuum hoses.
- Only use a reach tool to remove blockage from vacuum fan, fan housing or vacuum hose. Never use your hands to reach into the fan or fan housing.

After Blockage has been removed.

- Remove blocks from vacuum head and lower head to operating position.
- Remove debris body props
- Make sure no bystanders or coworkers are within 25 feet of the sweeper before starting the engine(s)
- Ensure no one is under or near debris body and lower debris body down vacuum head into operating position.

CRUSHING HAZARDS AND PREVENTION SAFETY

Never go under raised Debris Body until prop is installed	Never go under raised debris door until prop is installed	Truck can tip over while dumping debris on un-level surface	Slow down on curves, High Center of Gravity	Truck can tip over when truck wheels are on unstable ground

Figure 1-6

Debris Body Prop Support

WARNING

Never go under raised debris body until prop is installed. Failure to do so could result in personal injury or death.

1. Raise body sufficiently to allow body prop support to be swung into position.
2. Slowly lower body until body contacts body prop support.
 - To remove body prop support, reverse above procedure.

Debris Door Prop Support

WARNING

Always position debris door prop in proper position before entering any areas beneath debris door or entering body. Failure to do so could result in serious injury or death.

1. Raise debris door sufficiently to allow debris door prop support to be swung into position.
2. Slowly lower debris body until door contacts door prop support.
 - To remove debris door prop support, reverse above procedure.

Truck Tip Over

WARNING

Always wear seat belt while seated in truck to prevent injury.

- Truck driver must have valid applicable license and appropriate training before transporting liquids on public roads.
- Slow down on curves to prevent truck from tipping over.
- Always ensure unit is on firm and level ground before operating the dump system. When dumping, raise the body in steps, allowing the material to dump out in a steady flow.
- Do not allow people and/or vehicles beside debris body while dumping.
- Never drive truck with raised debris body.
- Keep truck away from drop-offs and soft soil ground where truck could tip over.

TRIP AND FALL PREVENTION SAFETY

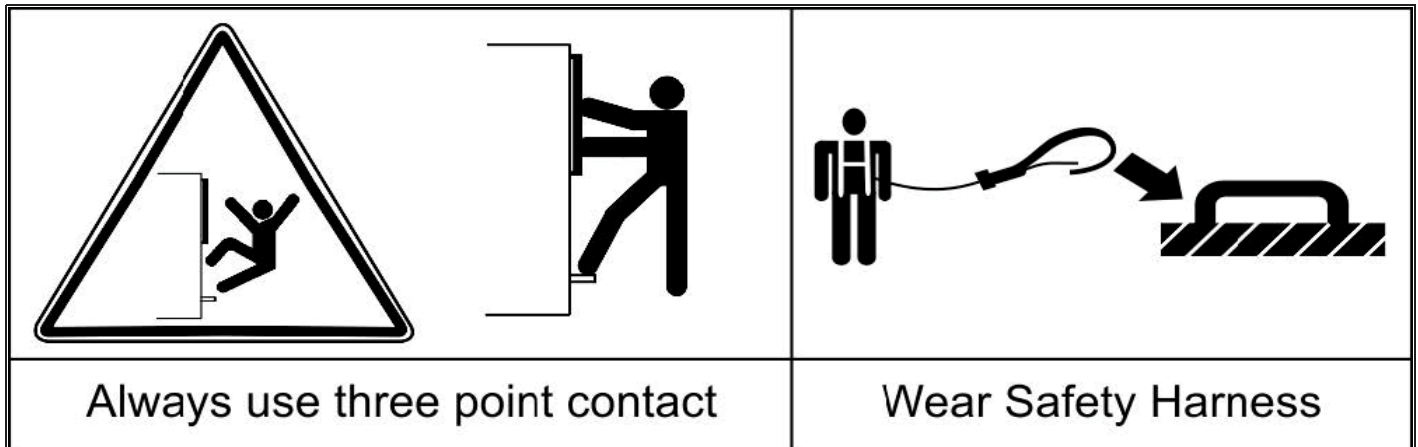

Figure 1-7

- **Always maintain** three-point contact with the machine, using two hands and one foot, or two feet and one hand, at all times during entry and exit. Never grab control levers or steering wheel when mounting or dismounting machine.
- **Walkways and steps** should be checked monthly to ensure a proper non-slip surface. Repair or replace damaged walkway or steps.
- **Keep** grab handles, steps, and walkways free of mud, oil, grease, and other foreign material. Clean non-skid surface material as required.
- **Ground level personnel** must be present whenever climbing onto unit to protect against inadvertent operation.
- **When servicing or working above ground,** occupants on elevated equipment surfaces must wear a full body harness with a lanyard attached to an authorized lanyard anchorage point. Attach only one lanyard per lanyard anchorage point.
- **Face the machine** when entering or leaving the elevated equipment surfaces.

HIGH-PRESSURE FLUID LEAK HAZARDS

High pressure oil penetrating skin	High pressure oil eroding skin	Using cardboard to check for oil leaks	Tank contents under pressure. Allow oil to cool before slowly removing cap

Figure 1-8

! DANGER

To avoid serious injury or death from high-pressure hydraulic oil leaks penetrating skin, follow these rules:

- Do not operate equipment with oil or fuel leaks.
- Keep all hydraulic hoses, lines, and connections tight and in good condition before applying pressure to the system.
- Relieve hydraulic pressure before servicing the hydraulic system.
- Remove and replace or test hydraulic hoses if a leak is suspected. Have a qualified service facility perform the test.

! DANGER

High-pressure fluid leaks can be invisible. When checking for hydraulic leaks and working around hydraulic systems, follow these rules:

- Always wear safety glasses and impenetrable gloves.
- Use paper or cardboard to search for leaks.
- Do not use hands or body parts to search for leak.
- Keep hands and body away from pin holes and nozzles ejecting hydraulic fluid.

! CAUTION

Use caution when removing hydraulic tank cap. Contents may be under pressure.

- **Allow oil to cool** before removing cap slowly.
- **Relieve** oil pressure before removing cap slowly.
- **Stay away** from hot oil that may spray from tank or hoses.

! DANGER

High-pressure hydraulic oil can puncture skin. If injured, seek immediate medical attention and inform the physician of the cause of the injury. Surgery is required to remove the fluid from the body. Failure to seek proper medical attention will result in serious injury or death.



Figure 1-9

POWER LINES/STATIC ELECTRICAL HAZARD WARNINGS

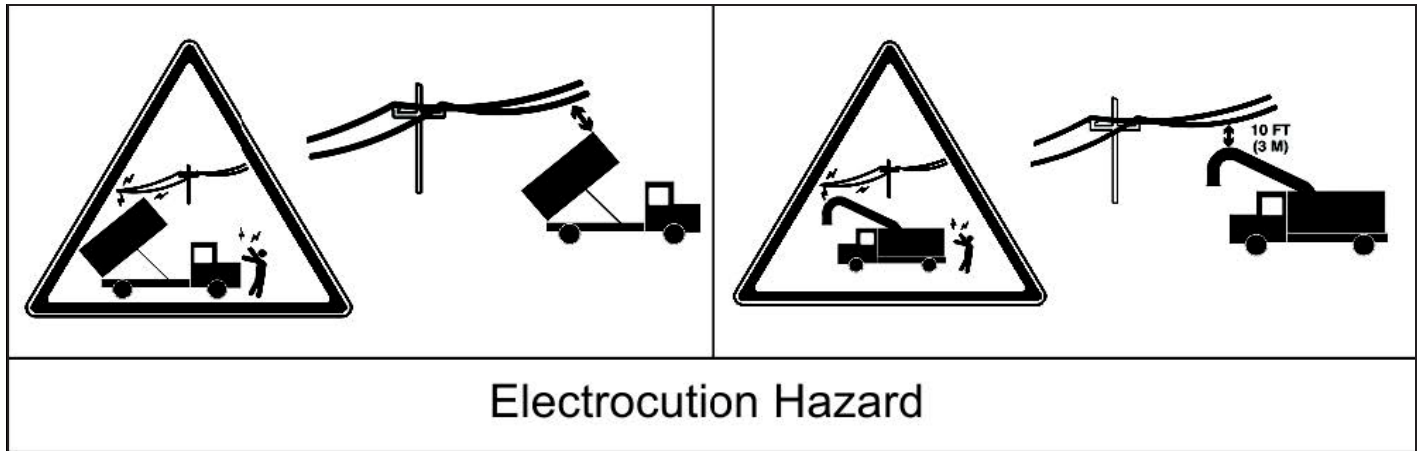

Figure 1-10

DANGER

This machine is not insulated and does not provide protection from contact or being near electrical current.

- **Never** operate the unit in an area where overhead power lines, overhead or underground cables, or other power sources may exist without ensuring that the appropriate power or utility company has de-energized the lines.
- **Always** check for power lines before raising boom or debris body.

Follow all requirements for using mobile equipment when working around power lines. The Occupational Safety and Health Administration (OSHA) requirements apply to most workers. The following information is from OSHA. Additional information can be obtained from www.osha.gov.

Overhead Power Line Tips for Construction Workers Before You Begin Construction Work

- Survey the site for overhead power lines.

NOTE

Never get within 10 feet of an overhead power line!

- Consider all overhead lines as energized until the electric utility indicates otherwise or an electrician verifies that the line is not energized and has been grounded.

CHEMICAL AND BIOLOGICAL HAZARD SAFETY



Figure 1-11

Chemicals and Diesel Engine Exhaust

WARNING

Operating, servicing and maintaining this equipment can expose you to chemicals including gasoline, diesel fuel, lubricants, petroleum products, engine exhaust, carbon monoxide, and phthalates, which are known to the State of California to cause cancer and birth defects or other reproductive harm. To minimize exposure, avoid breathing exhaust, do not idle the engine except as necessary, service your vehicle in a well-ventilated area and wear gloves or wash your hands frequently when servicing your vehicle. Battery posts, terminals and related accessories contain lead and lead compounds, chemicals known to the state of California to cause cancer, birth defects or other reproductive harm. For more information go to www.P65Warnings.ca.gov. This website, operated by California's Office of Environmental Health Hazard Assessment, provides information about these chemicals and how individuals may be exposed to them.

WARNING

Always read carefully and comply fully with the manufacturer's instructions when handling fuels, oils, solvents, cleansers, and any other chemical agent.

Chemical Waste Hazard

- Storm drains, catch basins, and sewers may contain harmful chemicals. To prevent contamination and injury.
- Seek immediate medical attention if exposure or contamination is suspected.

Biological Hazards

- Germs and other biological hazards are common in sewers, drains, and catch basins. Use appropriate personal protective equipment to avoid injury and contamination. Get medical attention for injuries associated with cleaning sewers, drains, and catch basins if biological contamination is suspected.

Dust Hazard

- Repeated or substantial breathing of hazardous dusts, including crystalline silica, could cause fatal or serious respiratory disease including silicosis. Concrete, masonry, many types of rock, and various other materials contain silica sand. California lists repairable crystalline silica as a substance known to cause cancer. Operation of this equipment under certain conditions may generate airborne dust particles that could contain crystalline silica. In those conditions personal protective equipment including an appropriate respirator must be used. If excessive dust is generated, a dust collection or suppression system should also be used during operation.
- Wear appropriate Personal Protective Equipment not limited to chemical resistant gloves, safety glasses, face shield and appropriate clothing.

TRANSPORT SAFETY AND HAZARDS WARNINGS

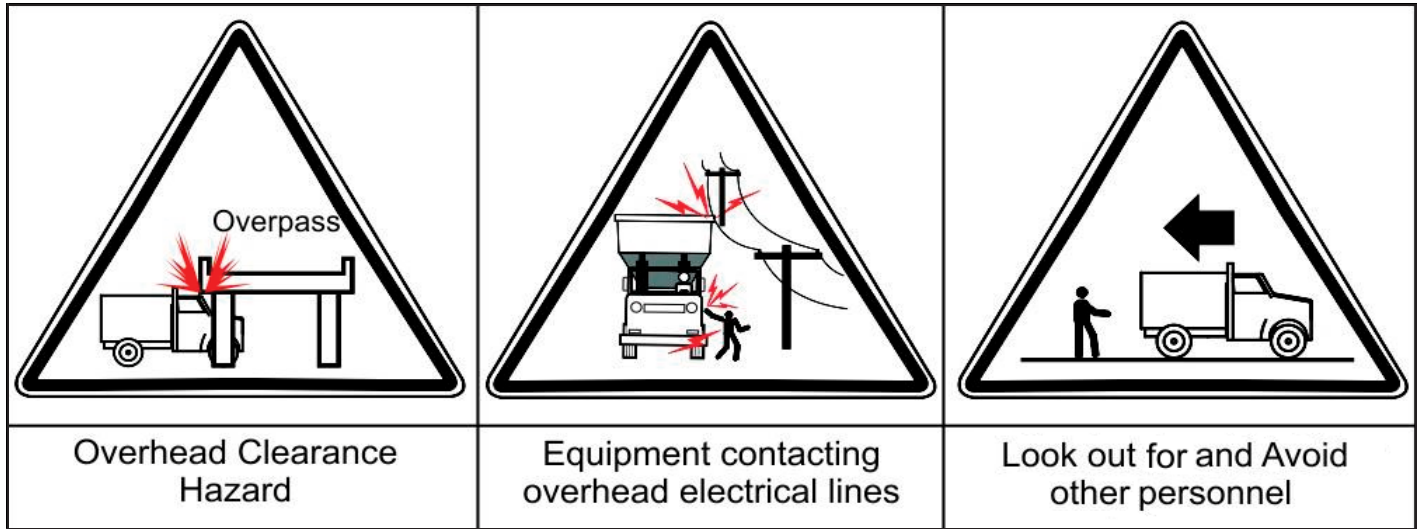

Figure 1-12

WARNING

Follow all steps before moving truck when towing or transporting equipment to avoid serious injury or death:

Never Exceed your Gross Vehicle Weight Rating (GVWR)

- In operation on public highways, the combined weight of the chassis, body, and payload must not exceed the gross vehicle weight rating of the chassis as rated by the chassis manufacturer.

Before Transporting Truck Inspection

- Ensure unit is road worthy by performing a pre-trip inspection before driving to and from job site.
- Check that debris door is closed and properly locked.
- Ensure all equipment is properly secured and positioned for maximum visibility and adequate clearances.
 - Close all water drain valves and install all plugs and strainers previously removed.
 - Check that boom (if equipped) is in transport position and properly secured.
 - Check that all tools, accessories, and work tubes/hoses are properly secured.
 - Check that cabinet doors and access panels are closed and properly secured.
 - Check that all clean-out doors are closed and latched shut.
 - Check that the dust chute and debris door are closed and latched shut.
- Always measure overhead clearance height of truck and equipment.
- Check for low hanging electric or telephone wires and power cables on the ground.
- Look out for and avoid other personnel, machinery and vehicles in the area. Use a spotter if you **do not** have clear view.

Pedestrian Safety

- Conduct a visual check and warning (honk horn) before starting or moving the truck to ensure the safety of people on the ground and other equipment in the area.
- Be aware of all personnel who are working on the ground.
- Look out for and avoid other personnel, machinery and vehicles in the area. Use a spotter if you **do not** have clear view.

TRANSPORT SAFETY AND HAZARDS WARNINGS — CONTINUED

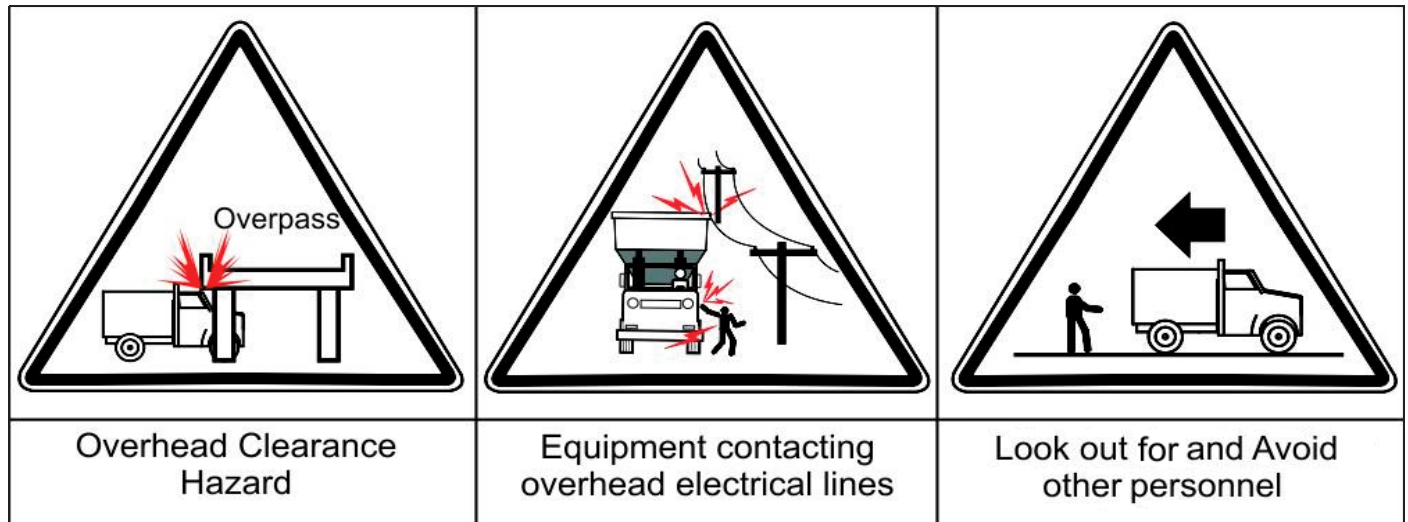

Figure 1-13

Determine Stopping Characteristics of Truck for Transport Braking

- Determine safe braking distances by performing braking tests in a safe location.
- Stopping distance with loaded debris body will be greater than empty truck.
- Reduce travel speed on wet or icy roads; stopping distances increase.

Determine Maximum Turning Speed Before Operating on Roads or Uneven Ground

- **Test** equipment by slowly increasing speed on turns to determine if it can be operated at higher speeds.
- **Use reduced** turning speeds on sharp turns to avoid equipment turning over.
- Truck has a high center of gravity when carrying a loaded debris body. Use extreme caution when transporting at highway speeds. Slow down for sharp corners to avoid tipping or turning over.

When Transporting Equipment

- **Do not move** truck unless debris body is fully lowered in the horizontal storage position.
- **Always** wear seat belt when operating truck.
- **Follow** all local traffic regulations.

- **Use** low speeds to avoid overturn when debris body is filled.
- Slow down and consider effects of water sloshing or debris movement.
- **Use** low speeds and gradual steering on curves, hills, rough or uneven surfaces, and wet roads.
- **Turn on** truck flashing warning lights when driving slower than traffic.
- Transport the truck only at safe speeds that allow for proper control of the truck while driving and stopping.

BACK OVER RUN-OVER HAZARDS

		
<p>Equipment contacting overhead electrical lines</p>	<p>Look out for and Avoid other personnel</p>	<p>Always use a spotter when possible</p>

This machine is equipped with a rear view camera to assist the driver in avoiding backing into objects or co-workers and bystanders. This rear-view camera is not a substitute for the machine's rear view mirrors or spotter.

- Always clean the rear-view mirrors and the rear-view camera and inspect daily before operating the machine.
- Check the rear view monitor at the beginning of each shift to ensure you can see clearly to the rear of the machine including the rear bumper. If the rear bumper is not visible in the monitor adjust the camera to ensure you can see the edge of your rear bumper. That way there will be no space between the rear bumper and camera viewing area that cannot be seen.

When backing following these best safety practices.

- Park and back defensively to prevent having to back up and possibly hitting co-workers, passersby, or objects.
- Always use a spotter when possible.
- Avoid backing whenever possible; Don't back up if you don't have to.
- When in doubt, don't back up.
- If turning in reverse, turn toward driver side if possible.
- Get out and look prior to backing.
- Check for all types of obstacles, including overhead.
- Back immediately after checking.
- Continually check mirrors on both sides of the machine while backing.
- Eliminate noise and other distractions before backing.
- Open your window so you can hear outside noises.
- Back slowly, in the lowest gear possible.

 **WARNING**

Use care when backing. Never try to back using the rear-view camera and monitor only! Use side rear view mirrors to aid vision as normal and use the rear-view monitor as you would a rear-view mirror on your automobile to watch for obstacles.

 **WARNING**

Make sure no bystanders, animals, or obstruction such as a vehicle, building, or street sign are behind the machine when backing up. The design of the machine impairs operator rear vision when backing. Use extreme caution to ensure that the machine is not backed into the path of pedestrian or vehicle traffic. If you cannot see to back clearly, stop the machine and examine the area. Serious injury or death and property damage could result from running into, being crushed by, or run over by a machine .

 **WARNING**

You will always have blind spots. Know their location, and try to minimize them. If you cannot see clearly request assistance to guide you while backing the machine .

SWEEPER & VACUUM EQUIPMENT HAZARD WARNINGS



		
<p>Do not put fingers in rotating components.</p>	<p>Do not put foot underneath sweeper.</p>	<p>Stop machine, Remove Key, Read Manual</p>

 **DANGER**

KEEP AWAY FROM ROTATING BLADES, BELTS AND PULLEYS TO AVOID SERIOUS INJURY OR DEATH FROM BLADE CONTACT:

- STAY AWAY and KEEP HANDS, FEET and BODY AWAY from rotating blades and parts until all moving elements have stopped.
- DO NOT put hands or feet under sweeper shielding.
- STOP rotating FAN BLADES disengage power and wait for blade to stop rotating before adjusting sweeper shields.
- STOP LOOK and LISTEN before approaching the sweeper to make sure all rotating motion has stopped.

THROWN OBJECT HAZARDS

	
<p>Thrown Objects Hazard</p>	<p>Inspect Area Remove large objects that could cause blockage in suction line.</p>

 DANGER
<p>SWEEPER CAN THROW OBJECTS 25 FEET OR MORE.</p>

TO AVOID SERIOUS INJURY TO OPERATOR OR PASSERBYS FROM THROWN OBJECTS:

- KEEP bystanders 25 feet away
- DO NOT operate if sweeper broom cover is open or missing. Broom can throw objects and result in serious injury or death.
- DO NOT operate if fan exhaust hose is removed. Fan can throw objects resulting in serious injury or death.

STOP SWEEPER IF PASSERBYS ARE WITHIN 25 FEET UNLESS:

- All THROWN OBJECT SHIELDING including, Steel Guards, and Bands, are in place and in good condition while operating.

SWEEPER THROWN OBJECT SHIELDING:

- KEEP all thrown object shielding including Steel Guards, Bands, and Side Skirts in place and in good condition when operating.
- DO NOT OPERATE with any thrown object shielding missing, damaged or removed.
- DO NOT try to sweep large debris that could cause suction line blockage.
- Remove material before sweeping.

VACUUM EQUIPMENT OPERATION SAFETY AND HAZARD WARNINGS

<p>Read and Understand Operator's Manual.</p>	<p>Ensure truck parking brakes are set.</p>	<p>Inspect equipment before operation. Ensure all components are operating properly.</p>	<p>Emergency Stop Button.</p>

Figure 1-14

It is the operator's responsibility to be knowledgeable of all potential operating hazards and to take every reasonable precaution to ensure that oneself, others, animals, and property are not injured or damaged by the operation of this equipment. Do not operate the equipment if passersby or untrained persons are within the active job site. Never operate this equipment if a shield or guard is missing or in poor operational condition.

NOTE

Read and understand all operating instructions and the entire safety section of this manual and the truck manual before attempting to operate any equipment.

If you do not understand any of the instructions, contact your nearest authorized dealer for a full explanation. Pay close attention to all safety signs and safety messages contained in this manual and those affixed to the unit.

WARNING

READ, UNDERSTAND, and FOLLOW the following Safety Messages. Serious injury or death may occur unless care is taken to follow the warnings and instructions stated in the Safety Messages. Always use common sense to avoid hazards.

WARNING

Always set the truck parking brakes and if on unlevel surfaces chock the wheels. Unexpected truck movement can cause serious injuries.

Before operating the equipment, conduct a walk-around inspection of the equipment for proper operation. Repair any improperly functioning, broken, or damaged equipment before operating. Inspect the job site for unsafe conditions and identify any potential hazards for operators and bystanders. Do not operate equipment if unsafe conditions cannot be controlled.

Emergency Stop Button Function

This equipment may be equipped with an emergency stop button that can be activated at any time during operation to disconnect the power and shut down the sweeping and dump operations.

Pressing the emergency stop button while the machine is in operation has the following results:

- All functions that are stopped will remain inactive

VACUUM EQUIPMENT OPERATION SAFETY AND HAZARD WARNINGS — CONTINUED





			
<p>Read and Understand Operator's Manual.</p>	<p>Ensure truck parking brakes are set.</p>	<p>Inspect equipment before operation. Ensure all components are operating properly.</p>	<p>Emergency Stop Button.</p>

Figure 1-15

 WARNING
<p>Make sure no one is near the end of the vacuum hose before engaging the vacuum pump. Failure to do so could cause personal injury.</p>

- Keep vacuum tools and hoses away from face and body. An injury caused by vacuum can be serious. The vacuum must be stopped as quickly as possible at any sign of danger. Seek medical attention immediately.
- Do not attach hose, pipe, or accessories with the vacuum on. The vacuum can trap fingers, hands, and feet with enough force to crush or cut.
- Make sure vacuum extension tubes are securely connected before engaging vacuum pump. Tube could fall and expose suction line.

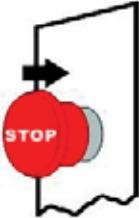
VACUUM EQUIPMENT OPERATION SAFETY AND HAZARD WARNINGS — CONTINUED

 CAUTION
<p>Failure to engage parking brakes and/or position wheel chocks could result in unexpected chassis movement, which could cause bodily injury or property damage.</p>

Prepare the job site

- Be aware of traffic and pedestrians on the job site. Use extreme caution while moving around the vehicle to avoid contact with other moving vehicles. Before stowing the boom or moving the vehicle, make sure pedestrians are clear of the area.

Arrange for Traffic Control

- If working near a road or other traffic area, contact local authorities about safety procedures and regulations.
- Always activate beacons and flashers before job setup.
- Always use safety cones.
- If working on a roadway, follow required temporary traffic control measures.
- Use job site controls, such as cones and barricade tape, to prevent bystanders from entering potentially hazardous areas.

Pre-Start Checklist

- Ensure operator and co-workers have read and understood the safety instructions in the Operator’s Manual.
- Prior to use ensure that all required maintenance has been performed.
- Park truck on level ground and set parking brakes.
- Ensure cleanout doors and debris door are closed and latched shut.
- Attach suction hose and tubing as required, including relief valve.

Plan for Emergency Services

Make sure you have the telephone numbers for local emergency and medical facilities on hand, and access to a telephone.

Vacuum Operation

- Operating the unit inside a building or confined areas can create additional risks to the unit, operators, and building occupants. Engine exhaust gas can reach deadly levels. Heat buildup from the engine and blower discharge can overheat equipment.
- Never use an air mover machine for vacuuming hydrocarbon or flammable materials.

 DANGER
<p>Never operate engines where there are or can be combustible vapors. Vapors pulled into an engine air intake can cause engine acceleration and over speeding. This can result in death, injury, and property damage.</p>

- The use of this equipment in the removal or handling of any regulated substance or material must be performed in strict accordance with all applicable federal, state, and local laws and regulations. Approved safety and personal protection equipment and clothing must be used and worn at all times.

DUST HAZARD AND EXPLOSION PREVENTION SAFETY

Figure 1-16

In a confined area, certain concentrations of dust in an otherwise normal atmosphere can explode when spark occurs. This phenomenon is known as a dust explosion. It has been known to occur in grain elevators, underground mines, flour mills, crushers, etc. The dust itself need not be an explosive or flammable substance.

The safe operation of transferring potentially explosive dust should be addressed by the following:

- Static charge dissipation
- Spark prevention

OPERATOR SAFETY

<p>Wear Gloves when refueling unit.</p>	<p>No smoking or open flames while refueling</p>	<p>Shut off Engine before refueling</p>	<p>Handle Fuel with care.</p>

WARNING

to avoid Serious Injury or Death follow these instructions

- READ, UNDERSTAND and FOLLOW Operator's Manual instructions, Warnings and Safety Messages.
- WEAR safety gloves when handling fuel, oils, lubricants and chemicals to prevent injury.

HANDLE FUEL SAFETY-AVOID FIRES

Handle fuel with care! It is highly flammable!

- Do not refuel the machine while smoking or when near open flame or sparks.
- Always stop engine before refueling machine. Fill fuel tank outdoors.
- Prevent fires by keeping machine clean of accumulated trash, grease, and debris. Always clean up spilled fuel.
- Use only an approved fuel container for transporting flammable liquids.
- Touch fuel container with fuel dispenser nozzle before removing can lid.
- Keep fuel dispenser nozzle in contact with fuel container inlet when filling.
- Always replace fuel tank cap after refueling and tighten securely.

Avoid Static Electricity Risk when Refueling

- Ultra-Low Sulfur Diesel (ULSD) fuel increase its ability to store a static charge. Static Charges can build up in ULSD fuel while it is flowing through the delivery hose. Static electric discharge when combustible fuel vapors are present can result in a fire or explosion.
- Therefore it is important to ensure the entire system (fuel supply, transfer pump, hoses, filters and nozzles) used to refuel your machine is properly grounded and bonded.

Handle Starter Fluid Safely

- Starter Fluid is highly flammable.
- Keep all sparks and flames away. Keep starting fluid away from batteries and cables
- Do not use starting fluid on an engine equipped with glow plugs or an intake heater.

FIRE HAZARDS

		
<p>In Case Of Fire</p>	<p>Stop the unit immediately. Move safely away from unit and fire.</p>	<p>Use Fire Extinguisher only for small fire.</p>

IN CASE OF FIRE:

- Stop machine immediately at the first sign of fire. Fire may be identified by the smell of smoke or sight of flames. Because fire grows and spreads rapidly, get off the machine immediately and move safely away from the fire. Do not return to the machine. The number one priority is your safety.
- Call the fire department.
- Equip machine with a properly charged fire extinguisher
- A portable fire extinguisher can put out a small fire or contain it until the fire department arrives, but portable extinguishers have limitations. Always put the safety of the operator and bystanders first. If attempting to extinguish a fire, keep your back to the wind with an unobstructed escape path so you can move away quickly if the fire cannot be extinguished.
- Read the fire extinguisher instructions and become familiar with their location, parts, and operation before a fire starts.

DEBRIS BODY DUMPING SAFETY AND HAZARD WARNINGS

Never go under raised Debris Body	Equipment contacting overhead electrical lines	Hand can be crushed by Debris Body	Truck can tip over when truck wheels are on unstable ground

Figure 1-17

WARNING

NEVER leave body raised or partly raised while vehicle is unattended or while performing maintenance or service under body unless body is propped to prevent accidental lowering. The debris body **MUST BE** empty for service work.

- **Never** attempt to prop a raised loaded debris body.
- **Never** attempt to raise body when vehicle is on unlevel ground.

WARNING

Never go under a raised loaded debris body. Never go under a raised body without securely propping it. Body must be empty.

- **Immediately** report any damage or malfunction of the unit or components to your employer.
- **Make sure** that all individuals and obstructions are clear of the hoist and body before operating the controls, and be ready to stop operation at any time that a hazardous condition might occur.

WARNING

Use extreme caution when dumping contents of the debris body. Ensure all personnel are at least 20 feet away from truck. Select a dump site that is on level ground and is clear of overhead obstructions. Serious injury or death to the operator and/or bystanders could occur if precautions are not taken when dumping the contents of the debris body.

- When positioning the truck at the dump station, choose an accessible location on level ground. Raising the debris body on unlevel ground increases the possibility of tipping.
- **Make sure** the area is clear of ground and overhead obstructions.
- **Never** raise the debris body unless you can clearly see all overhead structures. Stay clear of all utility lines.
- **Do not** dump the debris body over a pit area where the ground may cave in or is unstable.
- **Use care** when positioning the debris body at the dump station. Your vision, especially to the side and rear of the debris body, may be reduced by the size of the debris body. Use mirrors to aid vision. If you cannot see the dump site clearly, stop the truck and examine the area. If necessary, request assistance to guide you while backing the truck into position.
- **Never** drive with the debris body in the raised position. Traveling with the debris body in the raised position increases the chances of colliding with overhead obstructions. In addition, the center of gravity of the debris body is higher with a raised debris body, making the unit more prone to tipping over.

CONFINED SPACE HAZARD WARNINGS

			
Explosion Hazard	Chemical, Dust and Fumes Inhalation Hazard	Wear Respirator when around hazardous fumes	Never have an open flame

Figure 1-18

Confined Space Hazard

Follow all requirements for confined space when servicing. Debris body can be entered and are to be considered permit-required confined space as defined by the Occupational Safety and Health Administration (OSHA). The following information is from OSHA 3138-01R 2004. The full document can be obtained from www.osha.gov.

Many workplaces contain spaces that are considered to be “confined” because their configurations hinder the activities of employees who must enter into, work in, or exit from them. In many instances, employees who work in confined spaces also face increased risk of exposure to serious physical injury from hazards such as entrapment, engulfment, and hazardous atmospheric conditions. Confinement itself may pose entrapment hazards, and working in confined spaces may keep employees closer to hazards such as machinery components than they would be otherwise. For example, confinement, limited access, and restricted airflow can result in hazardous conditions that would not normally arise in an open workplace.

The terms “permit-required confined space” and “permit space” refer to spaces that meet OSHA’s definition of a “confined space” and contain health or safety hazards. For this reason, OSHA requires workers to have a permit to enter these spaces.

By definition, a confined space:

- Is large enough for an employee to enter fully and perform assigned work.
- Is not designed for continuous occupancy by the employee.
- Has a limited or restricted means of entry or exit.

These spaces may include underground vaults, bodies, storage bins, pits and diked areas, vessels, and silos.

DE-ENERGIZE AND LOCKOUT PROCEDURES

Electrical Wire Hazard	Hand Crushing Hazard	Remove key and read service/maintenance manual/handbook before servicing	Wait until all moving parts have stopped completely	Lock-Out

Figure 1-19

WARNING

Workers can be seriously or fatally injured if machinery they service or maintain unexpectedly energizes, starts up, or releases stored energy. Always de-energize equipment before working on or service machine.

1. Lower the debris body and debris door to the lowered transport position or onto the mechanical props to support the component.
2. Lower the boom (if equipped) to the storage position or to the lowest position.
3. Place the transmission in the park position.
4. Set the parking brake.
5. Turn off the engine and remove the keys.
6. Switch the battery power off if the truck has a battery disconnect switch, or disconnect the battery ground cables.
7. Lock the truck doors and securely store the truck keys.

NOTE

Follow all requirements for PPE when servicing equipment.

De-energization and lockout refer to specific practices and procedures to safeguard employees from the unexpected energization or startup of machinery and equipment or from the release of hazardous energy during service or maintenance activities.

De-energization requires the authorized employee to turn off and disconnect the machinery or equipment from its energy source(s) before performing service or maintenance and to either lock out or isolate the equipment/components to prevent the release of hazardous energy (e.g., electricity, compressed air, high pressure fluid, etc.).

Lockout devices hold energy-isolation devices in a safe or “off” position. They provide protection by preventing machines or equipment from becoming energized because they are positive restraints that no one can remove without a key or other unlocking mechanism or through extraordinary means, such as bolt cutters.

To properly de-energize this equipment:

HAZARDS WITH EQUIPMENT MAINTENANCE



WARNING

Avoid serious injury or death from component failure by keeping sweeper in good operating condition by performing proper service, repairs, and maintenance.

Before Performing Service, Repairs, and Maintenance on the Equipment

- Stop all engines, engage parking brake, lower sweeping gear, allow all moving parts to stop, and remove key before dismounting from truck.
- Place debris body, debris door, and boom in lowered position or securely block up with support props.
- Wear safety glasses, protective gloves and follow safety procedures when performing service, repairs and maintenance on the equipment.
- Allow components to cool before servicing or performing maintenance.
- Avoid contact with hot hydraulic oil tanks, pumps, motors, valves and hose connection surfaces.
- Securely support or block up raised framework and lifted components before working underneath equipment.
- Follow instructions in maintenance section when replacing hydraulic cylinders to prevent component from falling.
- Stop and shut off truck engine before doing any work procedures.
- Use ladder or raised stands to reach areas inaccessible from ground.
- Ensure good footing by standing on solid flat surfaces when getting on equipment to perform work.
- Follow manufacturer's instructions in handling oils, solvents, cleansers, and other chemical agents.
- Do not change any factory-set hydraulic calibrations to avoid component or equipment failures.
- Do not modify or alter equipment, functions, or components.
- DO NOT WELD or repair rotating components. These may cause vibrations and component failure being thrown from sweeper.

Performing Service, Repairs, Lubrication, and Maintenance

- Inspect for loose fasteners, worn or broken parts, leaky or loose fittings, missing or broken cotter keys, washers on pins, and all moving parts for wear.
- Replace any worn or broken parts with authorized service parts.
- Lubricate unit as specified by lubrication schedule.
- Never lubricate, adjust, or remove material while it is running or in motion.
- Torque all bolts and nuts as specified.

Safety Shields, Guards, and Safety Devices Inspection

- **Replace** any missing, broken, or worn safety shields, guards, and safety devices.
- **Replace** any damaged or worn safety warning decals. Damaged or worn decals need to be replaced with new ones.

PERFORM SERVICE, REPAIRS, LUBRICATION AND MAINTENANCE OUTLINED IN SWEEPER MAINTENANCE SECTION:

- **INSPECT** before each use for loose fasteners, worn or broken parts, leaky or loose fittings, missing or broken cotter keys and washers on pins, and all moving parts for wear.
- **REPLACE** any worn or broken parts with authorized service parts.
- **LUBRICATE** unit as specified by lubrication schedule
- **NEVER** lubricate, adjust or remove material while it is running or in motion.
- **TORQUE** all bolts and nuts as specified.

HAZARD WITH MAINTANENCE OF SWEEPER

<p>Risk of Battery Explosion Service Batteries Safely</p>	<p>Do Not attempt to remove the radiator cap. Only a trained mechanic should service the radiator.</p>	<p>Explosive separation of a tire and rim parts can cause serious injury</p>

WARNING

Avoid serious injury or death from component failure by keeping sweeper in good operating condition by performing proper service, repairs, and maintenance.

BATTERIES:

- Maintenance work on the batteries requires sufficient knowledge and the availability of proper tools.
- Keep naked flames, burning matches and spark sources clear of the battery; Risk of explosion.
- Never check the charging level of the battery by connecting the two poles with a metal object. Use an acid tester or voltmeter.
- Do not charge a frozen battery; Risk of explosion! Warm the battery to 16 °C beforehand.
- Battery acid can cause severe injuries by burning your skin and eyes. For this reason, wear suitable protective clothing.

COOLING SYSTEM:

- The engine cooling system is pressurized - use caution when removing radiator cap, the fluid may be under pressure.

Risk of burns! - For this reason, only remove the radiator cap with the engine switched off and after the engine has been able to cool.

TIRES:

- When working on the tires, make sure that the vehicle is secured against rolling, use parking brake and wheel chocks.
- Installing wheels and tires requires adequate knowledge and suitable tools.

- Repair work on the tires and wheels should be done by specially trained personnel using appropriate installation tools only.
- Check tire pressure regularly. Inflate the tires to the recommended pressures.
- Check the wheel nuts periodically. Missing wheel nuts can result in a wheel falling off and loss of control.

SERVICE TIRES SAFELY:

- Explosive separation of a tire and rim parts can cause serious injury or death.
- Do not attempt to mount a tire unless you have the proper equipment and experience to perform-the job.
- Always maintain the correct tire pressure. Do not inflate the tires above the recommended pressure. Never weld or heat a wheel and tire assembly. The heat can cause an increase in air pressure resulting in a tire explosion.
- Welding can structurally weaken or deform the wheel.
- When inflating tires, use a clip-on chuck and extension long enough to allow you to stand to one side and not in front of or over the tire assembly. Use a safety cage if available.
- Check wheels for low pressure, cuts, bubbles, damaged rims, or missing lug bolts and nuts. Remove and replace damaged tires.
- Wheels and tires are heavy, when handling wheels and tires use a safe lifting device or get an assistant to help lift, install, or remove.

HAZARD WITH MAINTANENCE OF SWEEPER

		
<p>Risk of Battery Explosion Service Batteries Safely</p>	<p>Do Not attempt to remove the radiator cap. Only a trained mechanic should service the radiator.</p>	<p>Explosive separation of a tire and rim parts can cause serious injury</p>

 **WARNING**

Operating, servicing and maintaining this equipment can expose you to chemicals including gasoline, diesel fuel, lubricants, petroleum products, engine exhaust, carbon monoxide, and phthalates, which are known to the State of California to cause cancer and birth defects or other reproductive harm. To minimize exposure, avoid breathing exhaust, do not idle the engine except as necessary, service your vehicle in a well-ventilated area and wear gloves or wash your hands frequently when servicing your vehicle. Battery posts, terminals and related accessories contain lead and lead compounds, chemicals known to the state of California to cause cancer, birth defects or other reproductive harm. For more information go to www.P65Warnings.ca.gov. This website, operated by California's Office of Environmental Health Hazard Assessment, provides information about these chemicals and how individuals may be exposed to them

This Page Intentionally Left Blank

1.14 Safety Decals Locations

NOTE

Schwarze supplies safety decals on this product to promote safe operation. Damage to the decals may occur while in shipping, use, or reconditioning. Schwarze cares about the safety of its customers, operators, and bystanders, and will replace the safety decals on this product in the field, free of charge (Some shipping and handling charges may apply). Contact your Schwarze dealer to order replacement decals.

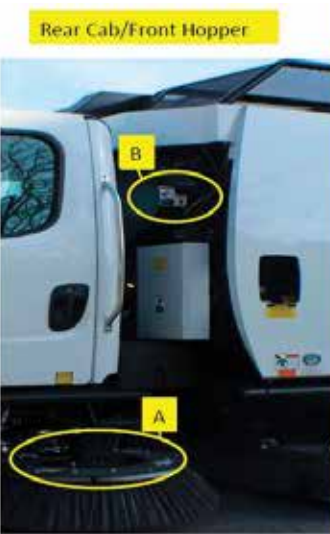
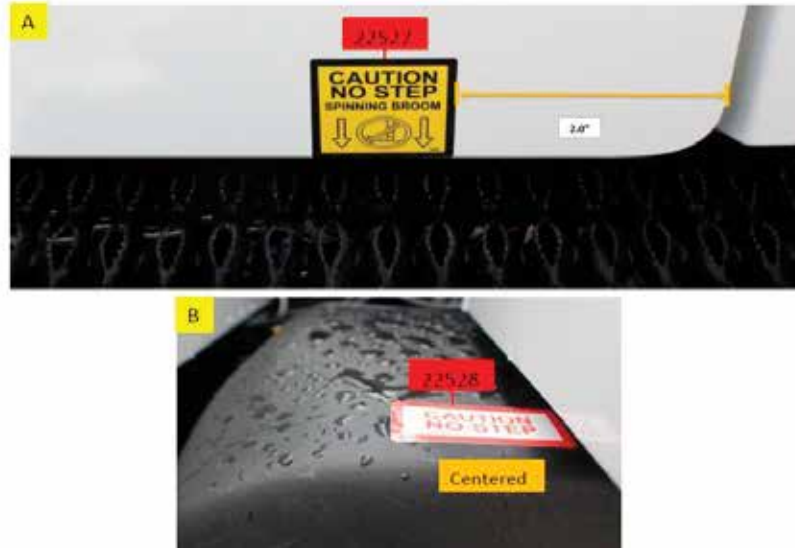
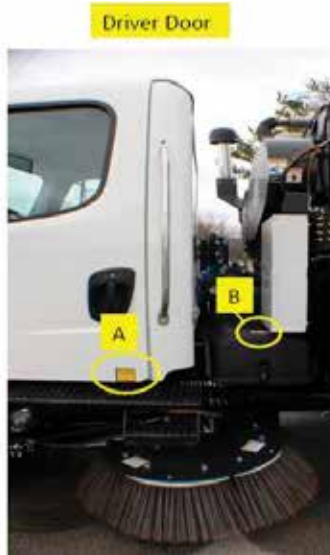

Note: Four stickers located on broom.

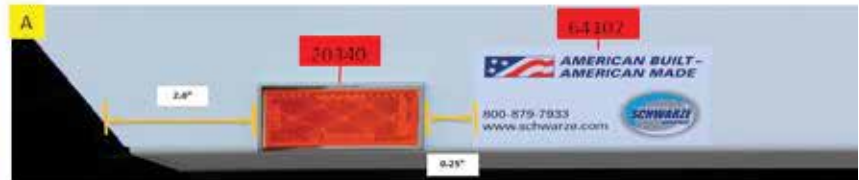
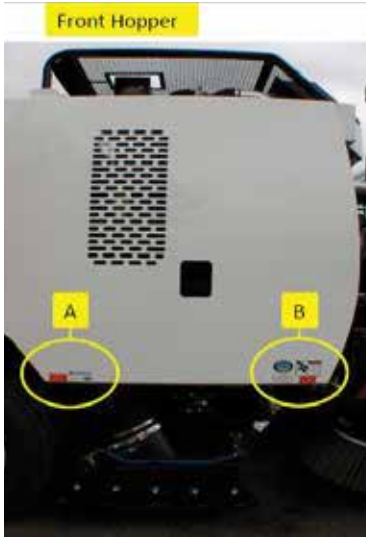
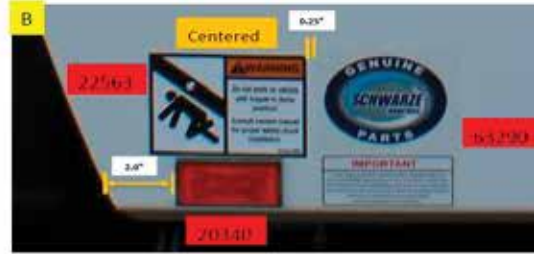

Note: Four
 Stickers
 Located on
 Broom

Front, Hopper Raised

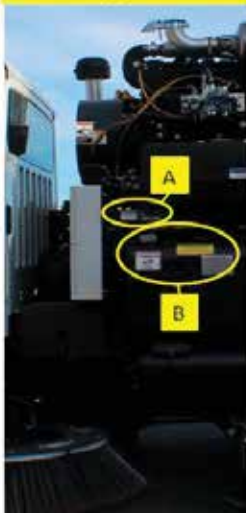

Middle, Hopper Raised



Rear, Hopper Raised

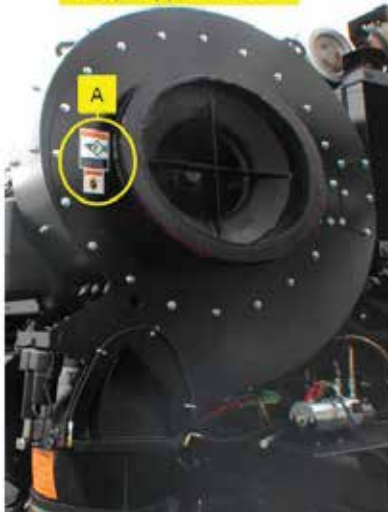

Rear, Hopper Raised

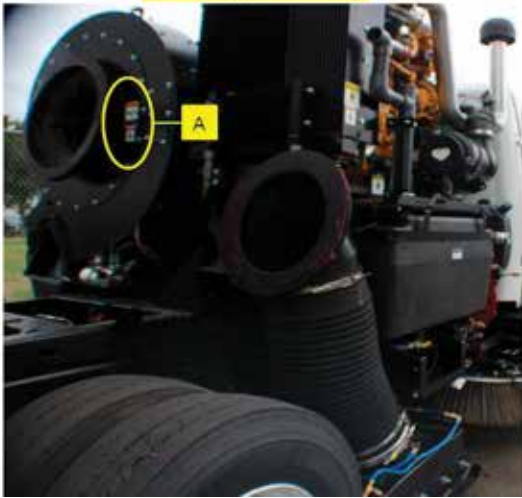

Middle, Hopper Raised

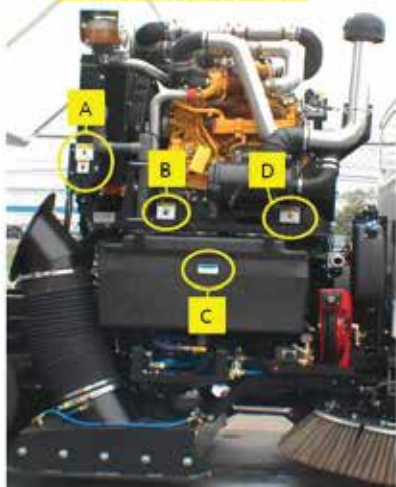

Top, Hopper Raised



Driver's Door

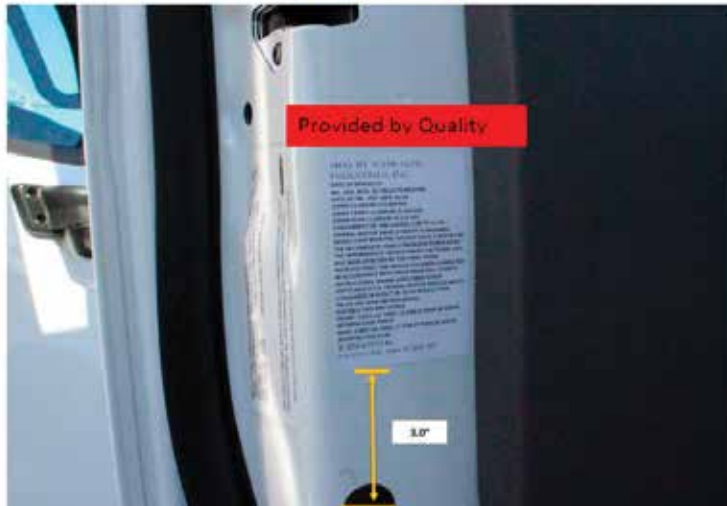

Interior Cab



Interior Cab, Dash



This Page Intentionally Left Blank

Section 2 - Technical Data

2

In this Section

Technical Drawings

Sweeper Specifications

Section 2 - Technical Data

Bortek
WE KNOW CLEAN

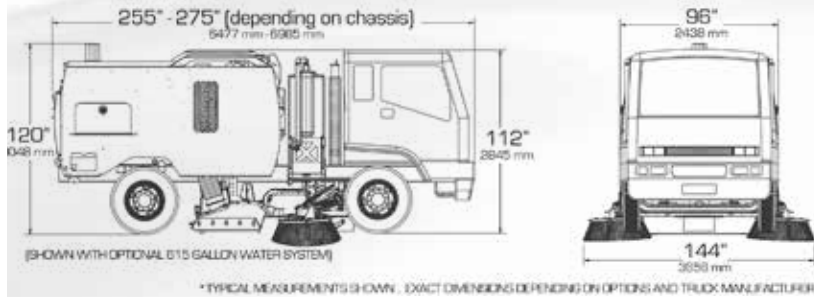

* TYPICAL MEASUREMENTS SHOWN. EXACT DIMENSIONS DEPENDING ON OPTIONS AND TRUCK MANUFACTURER

SWEEPING PATH

Pickup head only	90 in (2286 mm)
Head and 1 broom	117 in (2972 mm)
Head and 2 brooms	144 in (3658 mm)

CHASSIS

Mounts on various chassis to meet requirements

SWEEPER BODY

Construction	Welded 10-gauge stainless steel plate
Safety props	Lift spacers

STANDARD ENGINE

Model/type	4Q45T in-line 4 cylinder
Aspiration	Tier 4 Final turbo-charged diesel
Manufacturer	John Deere
Displacement	275 cu in. (4.5 L)
Brake horsepower	134 hp (100 kw) @ 2400 rpm
Torque	398 ft lb (540 Nm) @ 1600 rpm
Air cleaner	Centrifugal precleaner; dry type with safety element and restriction indicator
Oil filter	Full-flow/spin-on
Stroke	5 in (127 mm)
Bore	4.20 in (106 mm)
Compression ratio	19 to 1
Safety shutdown	Three-point automatic
Throttle control	Electronic

SWEEPER ELECTRICAL SYSTEM

Voltage	12 V
Engine alternator	90 amp

DUST CONTROL SYSTEM

Type	High pressure/low volume
Capacity	250 gallon (946 L)
Tank construction	Polyethylene filter; 50 mesh; cleanable
Fill diameter	2.5 in (63.5 mm)
Fill hose	25 ft (7620 mm)
Controls	Electric; in-cab
Nozzles	2 on each broom; 5 around suction head; 2 inside suction nozzle; 2 on front axle; 2 inside hopper
Water level gauge	In-cab

INSTRUMENTATION

Auxiliary engine	Flat panel display; tachometer; hourmeter; voltmeter; temperature gauge; oil pressure gauge; warning icons
------------------	--

FAN SYSTEM

Type	Closed-face radial
Drive	Direct via 5 groove; banded power belt
Construction	Hardox steel
Balance	1.5 grams on 2 sides
Diameter	32.75 in (832 mm)
Housing lining	Bolt-in corded rubber
Mounting	2 regreasable sealed bearings
Vacuum enhancer	For heavy/light material; in-cab indicator

PICKUP HEAD

Type	Dual chambered full-width blast orifice
Operating direction	Forward and reverse
Suspension	Adjustable spring balanced
Length	90 in (2286 mm)
Pressure hose diam	14 in (355.6 mm)
Suction hose diam	14 in (355.6 mm)
Hose construction	3/8 in (9.5 mm) wire-reinforced molded rubber
Head area	3240 sq in (20903 sq cm)
Controls	Hydraulic raise and lower
Skids	Double wide tungsten carbide
Construction	Abrasion-resistant steel inlet and outlet transitions.

SIDE BROOMS

Type	Vertical steel digger
Location	Right; left; forward of pickup head
Diameter	44 in (1118 mm)
Drive	Hydraulic
Suspension	Torque-sensing spring
Wear adjustment	Automatic
Pressure	Manual
Speed	Variable; non-reversing
Segments	5 each side; disposable
Tilt angle adjustment	In-cab controls

DEBRIS HOPPER

Volumetric capacity	8.4 cu yd (6.4 cu m)
Usable Capacity	7.0 cu yd (5.4 cu m)
Dump angle	51 degrees
Floor angle	3 degrees
Lifting	Twin hydraulic cylinders
Hopper dump door	Hydraulic open, close, lock
Inspection doors	1 on each side, pressure vessel lock
Hopper dump height	40 in (1016 mm)
Debris screens	Sawtooth drop down

HYDRAULIC SYSTEM

Type	Dual output 2 section
Pump capacity	8 gpm @ 1800 rpm (30 lpm) per section for 16 gpm total
Drive	Direct gear
Maximum pressure	2750 psi (190 bar)
Reservoir	25 gal (94 L)
Filter	10 micron; spin on
Protection	Pressure relief valve
Controls	Electro-hydraulic

AUXILIARY HYDRAULIC SYSTEM

Type	Gear type; driven by electric motor
Function	Lower hopper; open/close hopper door; raise brooms and pickup head

PAINT

One coat of sealer/primer and two coats of Dupont imron elite polyurethane in standard white color

OPTIONAL SWEEPER EQUIPMENT

Special Paint
Front Mounted Magnet Bar
Amber Beacon
Strobe Light Kit
Arrowboard Kit
Additional Flood Lights
Hopper Hand Hose
Remote Drop Down Screens
Hopper Dump Assist Shaker
12-volt Auxiliary Hydraulic System
Dual Steeling and Controls
Extra Water
High Pressure Front Spraybar
High Pressure Wash Dow
Side Air Blast Head
Hopper Deluge
Head Drain
Dual Outside Hopper Controls
Lifetime Hopper Warranty
Short Wheelbase Chassis

Note: Design and specifications subject to change without notice.

Section 3 - Pre-Operation

3

In this Section

Pre-Operation Inspection

Side Broom Pattern Check

Side Broom Pattern Check

The side broom pattern is the pattern of marks left on a sweeping surface after the sweeper has passed over it. You should check this pattern to verify the following conditions:

- That the broom is reaching the sweeping surface
- That the left-broom pattern is a 9-to-1 o'clock contact
- That the right-broom pattern is an 11-to-3 o'clock contact.

Inspection:

1. Move the sweeper to a flat asphalt or concrete sweeping surface and start the auxiliary engine.
2. Turn the side broom(s) on.
3. Allow the broom(s) to run in contact with the sweeping surface for about a minute or so.
4. Turn the side broom(s) off.
5. Raise the side broom(s).
6. Move the sweeper forward several feet to expose the surface just swept.
7. Turn off the truck engine and set the parking brake.
8. Get out of the cab and inspect the broom pattern.

If either pattern is irregular, the corresponding side broom tilt or down-pressure needs adjustment.

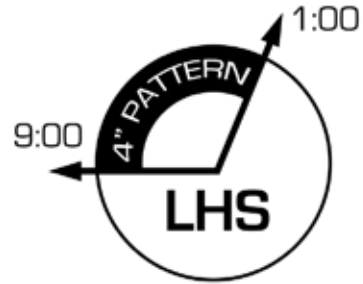

Left Side Broom

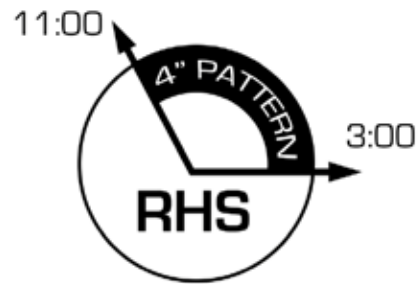

Right Side Broom

Section 4 - Operations

How your Schwarze A7 Tornado sweeper works

The Schwarze A7 Tornado regenerative air sweeper is mounted on a standard production truck chassis and uses a 'closed loop' to pickup debris from the pickup head.

The sweeper unit is powered by an auxiliary engine mounted on the sweeper frame. This engine propels a fan that draws air from the hopper and forces it down the pressure hose.

This air is then funneled across the front of the chamber, and out a slot, called the 'blast orifice.' As the air is pushed through the blast orifice, it is transformed into a high velocity stream that blasts forward and downward onto the sweeping surface in the pickup head's lower/front chamber.

The sheer force of this air loosens debris, then picks it up and pushes it across the pickup head in a spiraling motion and moves it towards the suction inlet on the vacuum side of the pickup head.

A series of flexible rubber flaps, called 'curtains,' are on the front and back of the pickup head. These curtains, along with the metal skid plates on each end, contain the high velocity air within the pickup head.

The vacuum inside the hopper, caused by the fan, pulls the debris up through the suction hose and into the hopper.

Once inside the hopper, a number of strategically placed water nozzles can be activated to decrease the amount of airborne dust.

As the dust comes in contact with the water, it will become heavy and also fall to the bottom of the hopper.

The air is then drawn through a screen to remove any remaining lighter debris. Any fine dust particles that might still remain after that are pulled into a dust separator.

The fan then draws the cleaned air from the dust separator back into the fan housing.

And the cycle begins again.

4

In this Section

The Sweeping Control Switches

The Hopper Control Joystick

The Display Module

Auxiliary Engine Start-up

Additional Optional Equipment

Sweeping Operation

End of Shift Cleanup and Maintenance

4.1 The Sweeping Control Console

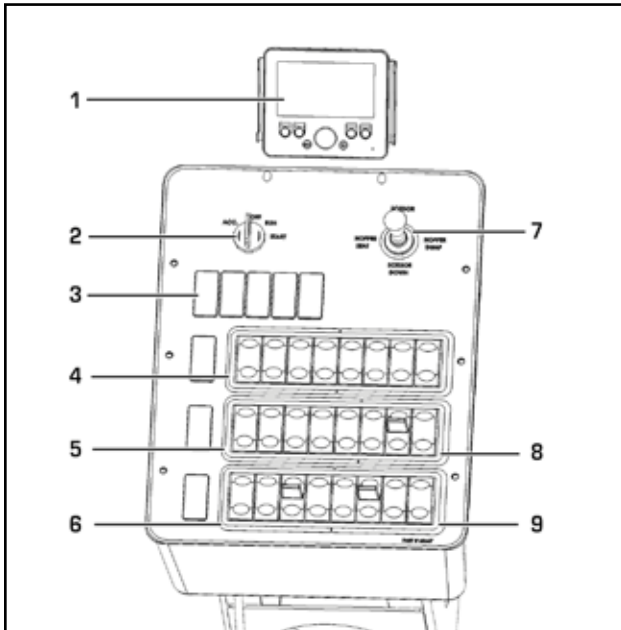

1. Display Module
2. Auxiliary Engine Ignition Key
3. Optional Function Switches
4. Water Function Switches
5. Lighting Function Switches
6. Left Side Broom Function Switches
7. Hopper Control Joystick
8. Regenerative Air Function Switches
9. Right Side Broom Function Switches

The A7 Tornado sweeping functions are operated from a swivel control console inside the truck cab. This console consist of control switches, auxiliary engine ignition switch, hopper control joystick, and display module with auxiliary engine controls.

Three rows of eight sealed back-lit rocker switches with text and icon labeling are grouped into 5 sections designated by different color bands.

The A7 Tornado utilizes “smart” control switches. When the control console is activated, all the switches will turn a blue color indicating the function is ready for activation.

When a toggle switch is pushed in the “on” position, depending on the function direction, either the bottom or the upper half of the toggle switch will turn red.

The display module shows a series of engine gauges, fluid levels, status indicators, warning messages, and additional operational data.

The console also provides areas for additional optional equipment switches.

Swivel the control console

To swivel the control console for a most comfortable operation, locate the lever located underneath the control console.

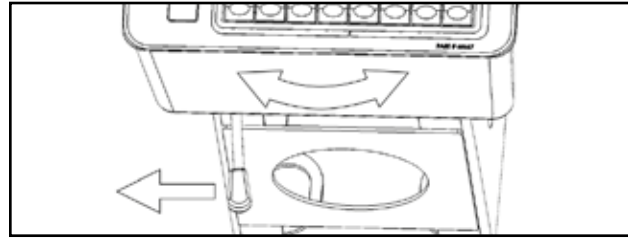

Pull the lever to the left and swivel the console left or right and release the lever when the desired position is found.

4.2 Water Switches

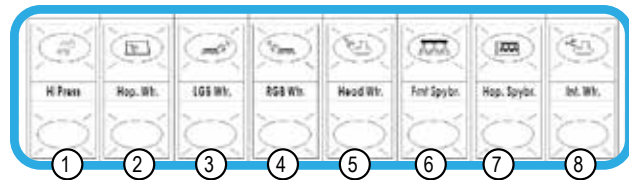

1. HI PRESS - High-pressure wash down
2. HPR WTR - Hopper water
3. LGB WTR - Left side broom water
4. RGB WTR - Right side broom water
5. HEAD WTR - Pickup head water
6. FRNT SPRAY - Front spray bar water
7. HOP SPRAY - Hopper spray bar water
8. INT WTR - Intake tube water

The water system is immediately available when the auxiliary engine is switched on.

Dust Suppression System Operation

Your sweeper is equipped with a number of convenient located water spray nozzles.

NOTE This function requires the auxiliary engine ignition key to be turned on.

Turning spray nozzles on

1. Locate the desired water switch on the cab console control panel.
2. Press the toggle switch to the “up” position.

Turning spray nozzles off

1. Press the toggle switch to the “down” position.

NOTE This is a standby controlled sweeping function.

High Pressure Washdown (if equipped)

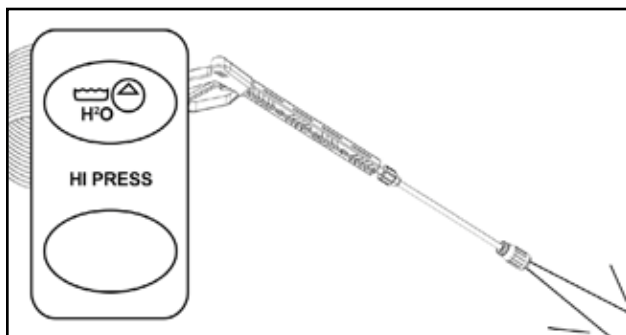

The washdown hose allows the operator to clean the sweeper while in the field when external water sources are unavailable. The washdown hose spray nozzle can be set from a wide spray to a narrow high pressure stream when needed.

IMPORTANT Before starting, all sweeper functions must be turned off, engine ignition key on and engine running in standby.

Turning the high pressure washdown on

1. Locate the switch on the cab console control panel.
2. Press the toggle switch to the “up” position.

Turning the high pressure washdown off

1. Press the toggle switch to the “down” position.

4.3 Lighting Switches



1. LGB LT - Left side broom light
2. RGB LT - Right side broom light
3. STROBE LT - Dump Lights: front, side and rear
4. BEACON LT - Beacon (if equipped)
5. ALT FLASH - 4 way flasher

To increase operational safety and better visibility, the A7 Tornado is equipped with a number of convenient located lighting options.

Turning lights on

1. Locate the desired light or flasher switch on the cab console control panel.
2. Press the toggle switch to the “up” position.

Turning lights off

1. Press the toggle switch to the “down” position.

4.4 Regenerative Air Switches



1. BLEEDER - Bleeder door operation
2. HEAD - Pickup head operation
3. STANDBY - Sweeper standby

Pickup Head Operation

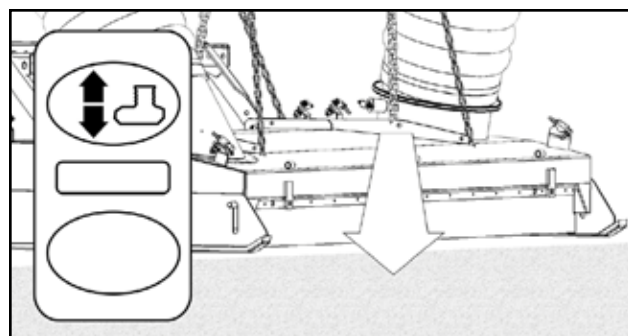

The pickup head is the actual sweeping component of the Schwarze A7 Tornado.

NOTE

Use of this function will automatically activate the auxiliary hydraulic pump if the auxiliary engine is off.

Lowering the pickup head

1. Locate the switch on the cab console control panel.
2. Press the toggle switch to the “down” position.

Bumping the pickup head for leaves and bulky material

1. Hold the toggle switch to the “up” position for less than 1 full second. This will raise the head slightly to allow bulky materials to pass the front curtains. Press the toggle switch to the “down” position to lower the head to its normal sweep position.

Raising the pickup head

1. Hold the toggle switch to the “up” position for more than 1 second.

NOTE

This is a standby controlled sweeping function

Bleeder Door Operation

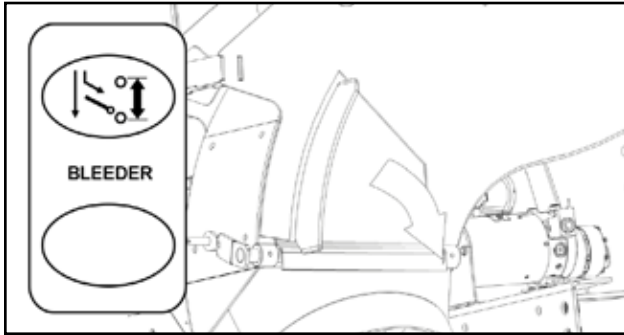

The bleeder door is normally closed but in instances of light debris or leaf sweeping, the bleeder door can be opened for a more efficient sweeping job.

NOTE Use of this function requires the auxiliary engine to be turned on.

Opening the bleeder door

1. Locate the bleeder door switch on the cab console control panel.
2. Press the toggle switch to the “down” position.
3. Press repeatedly or continue to hold the switch until the bleeder door has reached the desired position.

The status indicator screen will display the percentage of the bleeder door position. (See section 4.4.1.8 Main Indicator Area)

Closing the bleeder door

1. Press the toggle switch to the “up” position.
2. Press repeatedly or continue to hold the switch until the bleeder door has reached the desired or fully closed position.

NOTE It takes about eight seconds for the bleeder door to reach its fully open or closed position. However, the door may be positioned at any point between fully open or fully closed.

NOTE Using excess water to dampen leaves and other light debris tends to make them stick to the sweeping surface. Sometimes neither the blast force nor the vacuum suction can remove every bit of lightweight debris in this condition.

Sweeper Standby

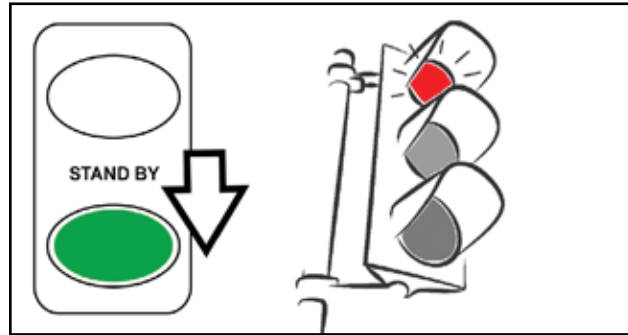

The sweeper standby controls the side brooms, pickup head, the water functions you have activated and the selected auxiliary engine speed.

After starting the chassis and auxiliary engine, the sweeper standby switch will flash red, indicating the standby system is functioning correctly.

Activating the sweeping system

1. Locate the switch on the cab console control panel.
2. Press the toggle switch to the “up” position

This allows the sweeping functions to be operated, and you may now start your regular sweeping operation.

Engaging the sweeper standby

1. Press the toggle switch to the “down” position.

This will turn off and raise the side brooms, raise the pickup head, turn off all water selections and lower the auxiliary engine speed to idle.

NOTE When engaged, the bottom half of the standby switch will blink green and the standby icon will appear on the display panel. Standby mode is also automatically engaged when the truck is put in reverse.

Dis-engage sweeper standby

1. Press the toggle switch to the “down” position again.

This will return the sweeper in “sweep mode”, re-activating the side brooms, pickup head, all water functions that were previously set, and will return the auxiliary engine to the previously selected speed, and you may now continue your regular sweeping operation.

If at this point you would rather de-activate the sweeper standby system instead of resuming sweeping operations, toggle the switch to the “up” position.

4.5 Side Broom Switches

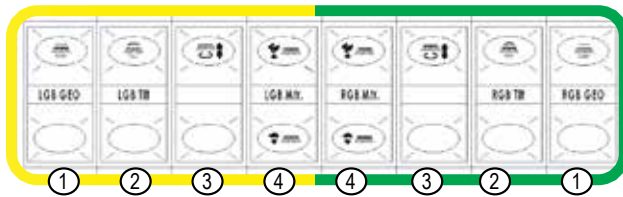

1. LGB/RGB GEO - Side broom extension override (GEOsm) (
2. LGB/RGB TILT - Side broom tilt
3. LGB/RGB - Side broom operation
4. LGB/RGB MTR - Side broom speed
5. LGB/RGB PRESS (not shown) - Side broom down pressure

Side Broom Operation

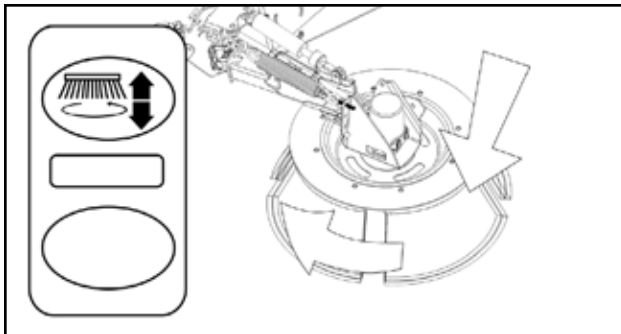

The main purpose of the side brooms is to loosen debris from the surface and direct it into the path of the pickup head.

NOTE Use of this function requires the auxiliary engine to be turned on.

NOTE The side brooms are “full floating”. When obstacles are encountered, the side broom will automatically pivot inwards temporarily until returning to its original sweeping position.

Starting the side broom

1. Locate the switch on the cab console control panel.
2. Press the toggle switch once to the “down” position.

The side broom will lower to the surface, extend and start spinning.

NOTE The side brooms always remain full contact with the pavement. As broom bristles wear away, the broom lowers to maintain contact with the surface.

Temporarily stopping the side broom rotation

1. Press the toggle switch again once to the “down” position.

The side broom will keep contact with the surface, but will stop spinning.

To resume the side broom again, toggle the switch once again in the “down” position.

Stopping and retracting the side broom

1. Press the toggle switch once to the “up” position.

The side broom will raise from the ground, retract and stop spinning.

NOTE This is a standby controlled sweeping function.

Side Broom Speed

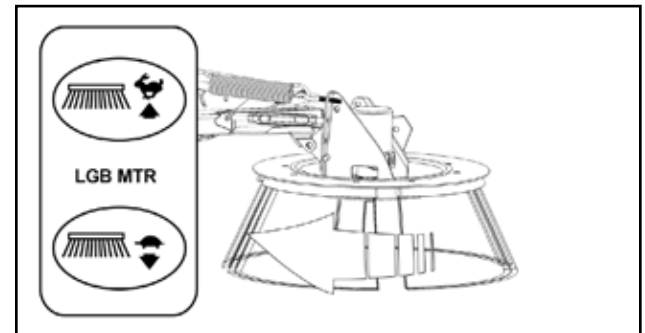

NOTE Use of this function requires the side broom to be on the surface and spinning.

Increasing the side broom speed

1. Locate the switch on the cab console control panel.
2. Press the toggle switch in the “up” position.
3. Press repeatedly or continue to hold the switch until the desired side broom speed has been established or until the broom is spinning at full speed.

Reducing the side broom speed

1. Press the toggle switch in the “down” position.
2. Press repeatedly or continue to hold the switch until the desired side broom speed has been established or until the broom is spinning at its lowest speed.

Side Broom Extension Override (if equipped)

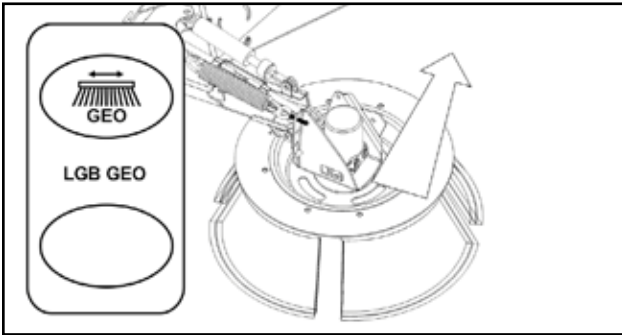

The extension override (GEO) allows the operator to override the side broom extension and retract it from its normal operating position inward under the truck so it can scrub the surface in front of the pickup head.

NOTE Use of this function requires the side broom to be on the surface and spinning.

Activating GEO and retracting the side broom

1. Locate the switch on the cab console control panel.
2. Press the toggle switch in the “up” position.

Returning the side broom to its extended sweeping position

1. Press the toggle switch in the “down” position.

Side Broom Tilt (if equipped)

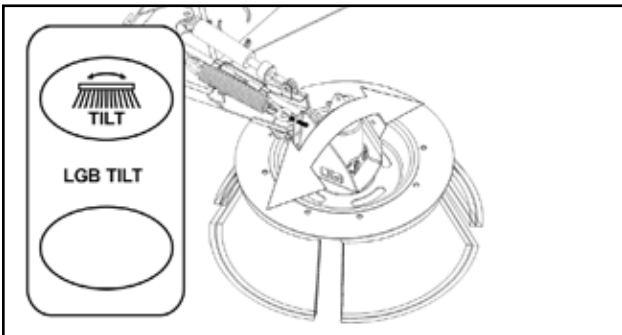

If your sweeper is not equipped with this option, please refer to “Adjusting the Manual Side Broom Tilt” in the service section of this manual.

The side broom tilt allows the operator to adjust the side broom tilt without having to exit the sweeper and manually adjust the tilt.

NOTE Use of this function requires the side broom to be on the surface and spinning.

Tilting the side broom

1. Locate the switch on the cab console control panel.

2. Press the toggle switch to the “up” position.
3. Continue to hold the switch until the desired side broom tilt has been established.

Returning the side broom to its normal level position

1. Press the toggle switch to the “down” position.
2. Continue to hold the switch until the side broom has returned to its normal level operating position

NOTE For optimum travel clearance, always return the side broom to its normal level operating position before retracting the broom.

Side Broom To Pavement Contact (Down Pressure) (if equipped)

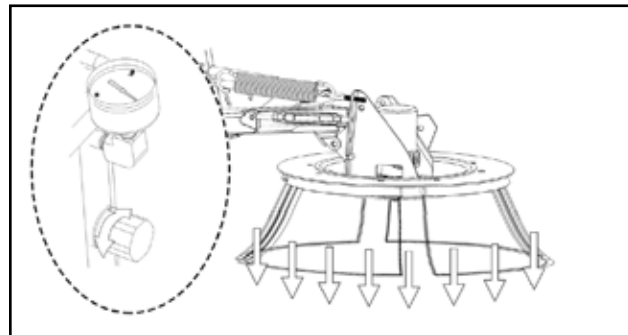

If your sweeper is not equipped with this option, please refer to “Adjusting the Manual Side Broom To Pavement Contact/Down Pressure” in the service section of this manual.

Valves located in the cab area control the amount of left or right side broom contact with the pavement.

NOTE Use of this function requires the auxiliary engine to be turned on, the side broom operation switch to be toggled in the “on” position and the side broom to be on the surface.

Applying more side broom to pavement contact.

NOTE Lowering the air pressure increases the amount of broom to pavement contact.

1. Turn the valve in a counter-clockwise direction.
2. Continue to turn the valve to increase broom to pavement contact until the desired amount of broom contact with the pavement has been established.
3. A gauge located near the valve will indicate the applied air pressure.

Applying less side broom to pavement contact.

- NOTE** Raising the air pressure decreases the amount of broom to pavement contact.
1. Turn the valve in a clockwise direction.
 2. Continue to turn the valve to decrease broom to pavement contact until the desired amount of broom contact with the pavement has been established.
 3. A gauge located near the valve will indicate the applied air pressure.

4.6 Additional Optional Switches

Your A7 Tornado may be equipped with a variety of additional switches.

Magnet Bar (if equipped)

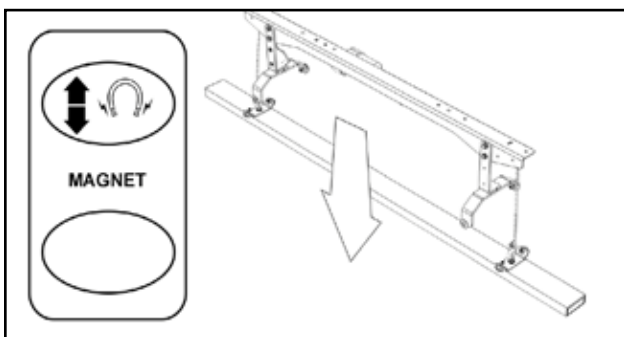

The main function of the magnet bar is to remove metal objects that may cause damage to the truck tires.

- NOTE** Use of this function requires the auxiliary engine to be turned on.

Lowering the magnet bar

1. Locate the switch on the cab console control panel.
2. Press the toggle switch in the “down” position.
3. Continue to hold the switch until the magnet bar is fully lowered.

The magnet bar will automatically stop when it reaches the proper distance from the ground.

Raising the magnet bar

1. Press the toggle switch in the “up” position.
2. Continue to hold the switch until the magnet bar has fully retracted against the up-stops.

- NOTE** Unless equipped with a self dumping magnet, objects that were picked up must be manually removed from the magnet.

Self Dumping Magnet (if equipped).

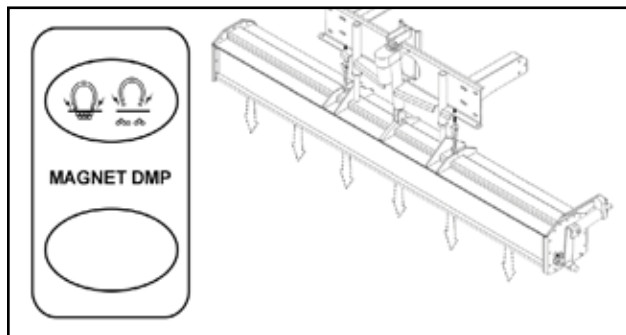

Releasing (dump) objects from the self dumping magnet.

1. Locate the switch on the cab console control panel.
2. Press the toggle switch in the “down” position.

Driver Position (if equipped)

This horizontal switch is located on the chassis center console. It allows the operator to enable driving functions from either side of the cab.

- NOTE** It is recommended to always operate the sweeper from the left side of the chassis while transporting the sweeper at traffic speeds.

1. Stop the truck in a safe area and set the parking brake.
2. Take the truck transmission out of gear and put in neutral.
3. Toggle the chassis dual steering switch so that the right steering position is empowered.

Realign the sweeper’s mirrors for the right hand steering position

4.7 The Hopper Control Joystick

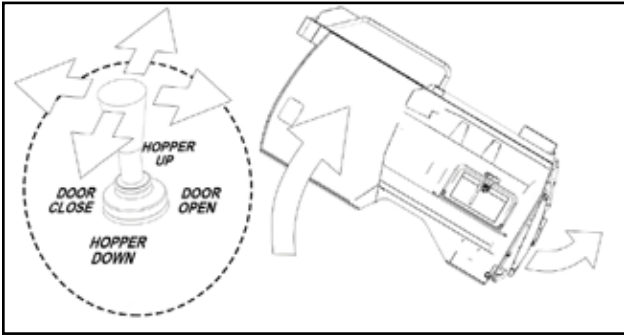

The joystick operates in four directional functions.

NOTE Use of the joystick automatically activates the auxiliary hydraulic pump if the auxiliary engine is off.

NOTE Due to the high electrical load generated when using the auxiliary pump it is best to run the auxiliary engine whenever possible. Use of the electric pump is recommended for service and emergency offloading only.

NOTE Engagement of the parking brake is required to dump the hopper or operate the hopper door. The brake may then be released for load spreading.

Dumping the hopper (Hopper Up)

1. Apply parking brake.
2. Push the joystick up until the desired height has been reached or until the hopper has reached its highest dump height and has stopped moving.

NOTE The hopper vibrator (if equipped) will activate for 20 seconds after the joystick is activated to help dump the hopper.

Lowering the hopper (Hopper Down)

1. Push the joystick down until the desired height has been reached or until the hopper has fully retracted and has seated on the fan and intake tubes.

Opening the hopper door (Door Open)

1. Apply parking brake.
2. Push and hold the joystick to the right until the hopper door has been fully opened.

Closing the hopper door (Door Close)

1. Push and hold the joystick to the left until the hopper door has been fully closed.

4.8 The Display Module

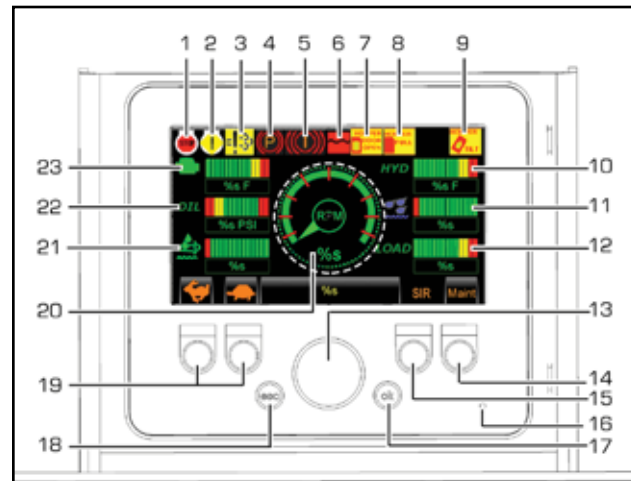

1. Auxiliary Engine Shutdown Required (If Shown)
2. Auxiliary Engine Fault Code Has Been Set (If Shown)
3. Auxiliary Engine Diesel Emission Fault Code Has Been Set (If Shown)
4. Parking Brake Applied (When Shown)
5. Sweeper In Stand By Mode (When Shown)
6. Low Hydraulic Levels (If Shown)
7. Hopper Door Open (When Shown)
8. Hopper Full (When Shown)
9. Hopper Tilted (When Shown)
10. Hydraulic Oil Temperature Indicator
11. Dust Control Water Level Indicator
12. Hopper Load Indicator
13. Menu Navigation Pad
14. Maintenance Menu Selections
15. Sweeps-In_Reverse
16. System Status Indicator Light
17. OK - Menu Item Select Button
18. ESC - Return To Previous Menu Button
19. Auxiliary Engine Speed Controls
20. Warning and Message Indicator Area
21. Auxiliary Engine Diesel Emission Fluid (DEF Level Indicator)
22. Auxiliary Engine Oil Pressure Indicator
23. Auxiliary Engine Coolant Temperature Indicator

Main Indicator Area

The main indicator area can display various warning and operational information.



Auxiliary Engine Speed Gauge



Bleeder Door Position Indicator

When shown, the bleeder door has been activated and the current position is displayed and will remain on screen for 2 to 3 seconds after the switch is released.

Auxiliary Engine Speed Controls

These two buttons control the auxiliary engine speed and are indicated with a rabbit and tortoise icon.

Increasing Auxiliary Engine Speed

1. Push the left button (rabbit icon) to increase the auxiliary engine speed by 100 rpm increments.
2. Press repeatedly or continue to hold the button until the engine rpm has reached the desired engine speed or has reached full throttle.

Reduce Auxiliary Engine Speed

1. Push the right button (tortoise icon) to reduce the auxiliary engine speed by 100 rpm increments.
2. Press repeatedly or continue to hold the button until the engine rpm has reached the desired engine speed or has reached idle position.

Sweeps-In-Reverse Selection

NOTE This function may have been disabled at customer's request.

By default, when the A7 Tornado is put in reverse, the side brooms and pickup head are automatically raised, side brooms are turned off and the auxiliary engine is placed in idle.

If the Sweeps-in-reverse function is activated, putting the sweeper in reverse will raise the side brooms but will leave the head down and the engine running at current speed.

Activating Sweeps-In-Reverse

1. Push the sweeps-in-reverse selection button (indicated with SIR immediate above the button)

The SIR icon will be highlighted green immediately above the button.

The pickup head and auxiliary engine will now be unaffected when in reverse.

NOTE The sweeper standby function is not be available in sweep-in-reverse.

Disabling Sweeps-In-Reverse

1. Push the sweeps-in-reverse selection button.

The highlighted green portion of the SIR icon will disappear above the button.

The pickup head will now be raised and auxiliary engine will be put in idle when in reverse.

NOTE Putting the sweeper back in forward will automatically return the side brooms and pickup head to their previous positions and the auxiliary engine will return to its previous speed.

4.9 Auxiliary Engine Start-up

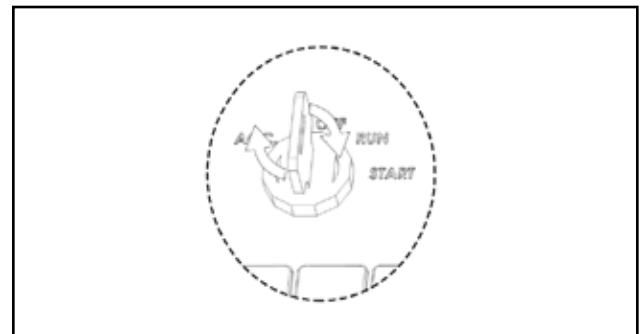

WARNING Before starting the auxiliary engine in a confined area, verify that proper outlet exhaust ventilation equipment is installed. Always use safety approved fuel storage and piping.

Starting the Auxiliary Engine

- Turn the key switch clockwise.
- When the engine starts, release the key so that it returns to the "Run" position.

IMPORTANT If you release the key switch before the engine starts, to prevent damage to the engine, you must wait until the engine comes to a complete stop before attempting to restart.

- Check all gauges for normal engine operation. If operation is not normal, stop the engine and notify your supervisor.

Engine Oil Pressure

Normal engine oil pressure should be $380 \pm 103\text{kPa}$ (3.80 bar \pm 1.03 bar; 55 \pm 15 psi) at rated full-load speed (1800 - 2500 rpm) with oil at normal operating temperature of 105°C (220°F).

If the gauge needle does not rise above the minimum oil-pressure specification of 103 kPa (1.03 bar; 15 psi) within 5 seconds, stop the engine and notify your supervisor.

Coolant Temperature Gauge.

Normal engine coolant temperature range is 82° - 94°C (180°-202°F).

IMPORTANT Do not place the engine under full load until it is properly warmed up.

Warming the engine

To assure proper lubrication, warm the engine by operating it at 1200 rpm with no load for 1 to 2 minutes.

IMPORTANT When operating at temperatures below freezing, extend this period to 2 to 4 minutes.

Idling the auxiliary engine

IMPORTANT Avoid unnecessary engine idling and never allow the engine to idle longer than 5 minutes. Prolonged idling could cause crankcase oil dilution, formation of gummy deposits, engine sludge and unburned fuel in the exhaust system

Slow idle for this engine is set at 850 rpm at the factory. If you must leave the engine running more than 3 to 4 minutes, make sure the engine speed is at 1200 rpm.

Recommended auxiliary engine speeds

Light sweeping operation	1600-1800 rpm
Normal sweeping operation	1800-2000 rpm
Heavy sweeping operation	2000-Full rpm

IMPORTANT We advise operating the engine under a lighter load and at lower speeds than normal for the first few minutes after start-up.

NOTE This is a standby controlled sweeping function

4.10 Camera System

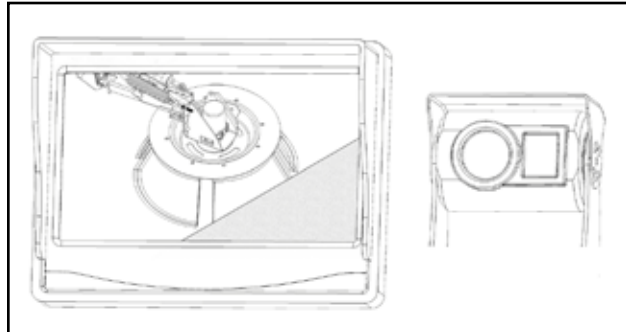

To increase the operator's field of vision, a camera system is installed on your sweeper.

Standard, one camera is mounted at the rear of the hopper to view what is directly behind the sweeper. In a multi-camera system, the picture on the camera system automatically switches to the rear view when the sweeper is shifted into reverse.

Two additional cameras (if equipped) are mounted near the left and right side broom. This allows observation of the side broom operation as well as provide a view of approaching curb line obstacles.



Each camera view can be displayed by pressing the "Scan" or "Camera Select" buttons on the camera display system.

For additional camera functionality or camera system troubleshooting please refer to the camera system manufacturer's owner's manual, which is provided with the A7's sweeper manual set.

4.11 Additional Optional Equipment

Your sweeper may be equipped with a variety of additional optional equipment.

Hand Hose (if equipped)

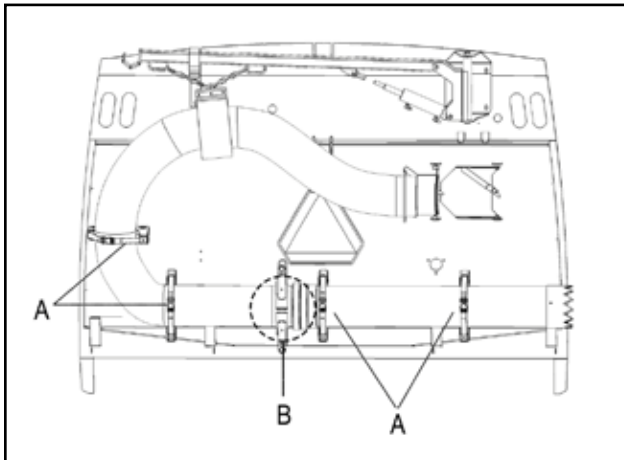

- A Hand Hose Transport Straps (Remove top operate hose)
- B Hand Hose Control Handle (With lift and throttle control)

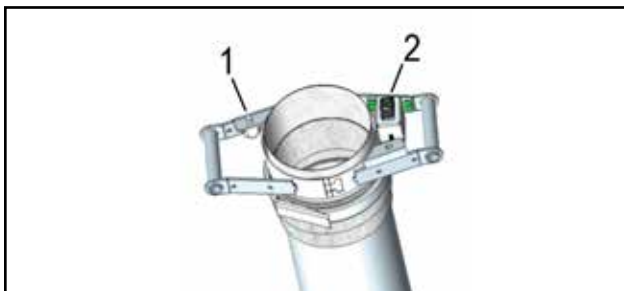

- 1 Hose Boom Up/Down Control Toggle Switch
- 2 Engine Throttle Control Rocker Switch

The hand hose is mounted on a hydraulic boom hinged to the right rear of the sweeper. The hose operates via suction within the hopper.

Operating the hand hose

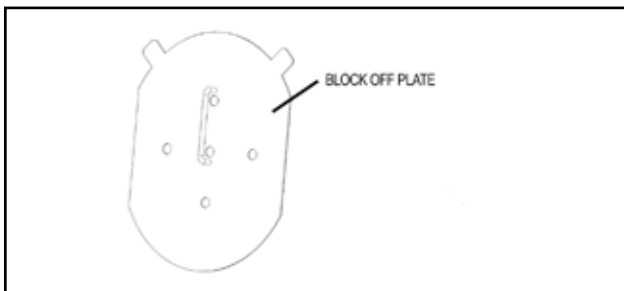

1. Locate the block-off plate in its storage location.
2. Raise the hopper.

3. Place pickup head block-off plate over the pickup head's transition hose opening on the driver's side of the sweeper.

WARNING Never put the block-off plate in place while the engine is running.

4. Lower the hopper.
5. Unhook the cords that hold the hose and tube to the brackets.
6. Release the straps that hold the hose and aluminum nozzle to the support.

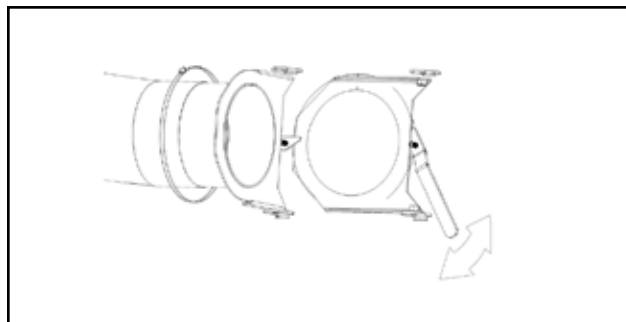

7. Pull the lock levers down on the hose door latch located in the back of the sweeper to reveal the suction door opening.
8. Swing the hand hose end in place flat against the opening and lock the hand hose latches.
9. Swing the boom out and away from the rear of the hopper

The hand hose is now ready for use.

Use the engine throttle to control the amount of vacuum.

NOTE If a straight drop into a catch basin is required, hang the tube directly over the hole to operate in a straight vertical position.

NOTE When using the hand hose in or around water, do not hold the end of the nozzle completely under the water surface. Doing so will result in the loss of suction.

DANGER Never vacuum flammable liquid. Fire and explosion may occur

Re-seating the hand hose

1. Re-seat (stow) the hand hose by swinging and holding the boom over the cradle.
2. Use the hand hose door latch to close the suction door opening.

3. Release the hand hose latches and swing open the hand hose end.
4. Re-attach the straps that hold the hose and aluminum nozzle to the support.
5. Hook up the cords that hold the hose and tube to the brackets.
6. Raise the hopper.
7. Remove the pickup head block-off plate from the pickup head's transition hose opening on the driver's side of the sweeper.

WARNING Never remove the block-off plate while the engine is running.

8. Return the block-off plate to its storage location.
9. Lower the hopper.

Hopper Drain (if equipped)

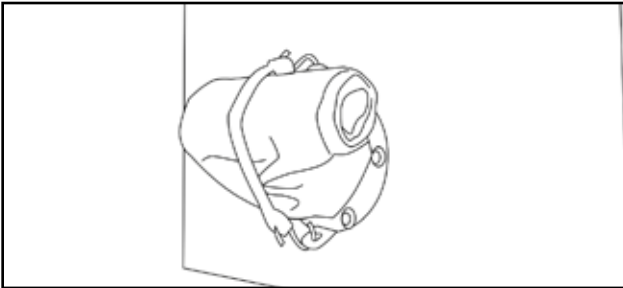

The hopper drain, located in the rear of the hopper, offers the option to drain liquid from the hopper, such as rain water, to reduce load weight during wet weather and allow longer dumping intervals.

NOTE Local rules and regulations may require that liquid picked up by the sweeper be removed at the dump site.

Hopper Deluge (if equipped)

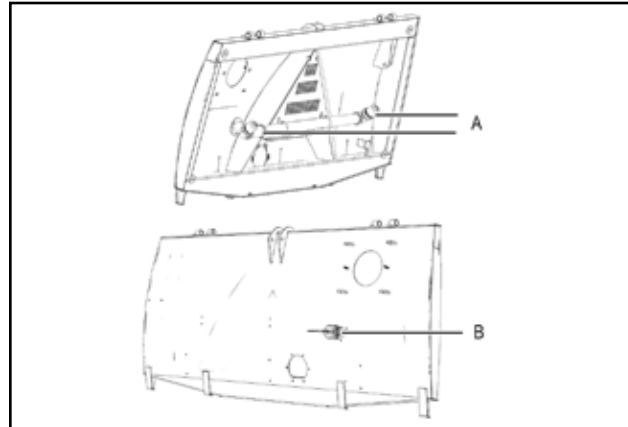

A Hopper Deluge System
B Fire Hose Connection

The hopper deluge, located in the rear of the hopper, allows a 2^{1/2}" fire hose connected to a fire hydrant to be connected to the hopper and allow the inside of the hopper and hopper screen to be cleaned with a massive amount of pressurized water. The Schwarze Deluge blasts free dirt and stubborn grime adhering to the inside and drastically shortens sweeper cleanup.

NOTE Local rules and regulations may restrict you from using a fire hydrant for cleaning purposes.

4.12 End of Shift Cleanup and Maintenance

Your new sweeper has been quality engineered to provide years of dependable service. End of shift cleanup is a major factor in keeping your unit in like-new condition.

NOTE Allow at least half an hour at the end of a day's sweeping to properly clean the unit.

Cleaning is an important part of any maintenance program because it extends the life of the sweeper by reducing rust and abrasion. Additionally this gives the opportunity to inspect for any damaged or worn parts needing service or replacement.

Generally, a high volume of water cleans best: using a



regular garden hose.
Before starting end of shift cleanup, always verify that:

- The truck is out of gear.
- The parking brake is engaged.
- Hopper safety props are into position.

1. Lower hopper to ground level and tilt hopper
2. Start the side brooms and temporarily stop them from spinning
3. Thoroughly hose down the brooms, center dirt deflector, pickup head and hopper.
4. Wash the inside of the pickup head's suction hose.
5. Retract side brooms to their travel positions.
6. Turn off the auxiliary and chassis engine.
7. Hose down the unit to completely rinse away all dirt and dust.

IMPORTANT

Do not spray water directly onto the engine components, computer components or bearings.

8. Clean away debris that may have become wound around the side brooms.
9. Lubricate all daily lubrication points
10. Check the odometer and hour meter and perform any other needed lubrication.
11. Inspect the sweeper for loose hardware, oil leaks, burned-out bulbs or fuses, tire wear and inflation, and so on.
12. Report any problems to your supervisor.

This Page Intentionally Left Blank

Section 5 - Troubleshooting

Troubleshooting your Schwarze sweeper

Schwarze sweepers are carefully designed and built with quality materials and should be maintained using quality parts. These parts are made and tested to Schwarze specifications.

Non-genuine “will fit” parts do not consistently meet these specifications. The use of “will fit” parts may reduce the sweepers performance, void warranties, and present a safety hazard. Use genuine Schwarze sweeper parts for economy and safety.

5

In this Section

Troubleshooting the Sweeping System

Troubleshooting the Sweeper Engine

Troubleshooting the Water System

Troubleshooting the Hydraulic System

Troubleshooting the Side Brooms

Troubleshooting the Camera System

Troubleshooting the Automatic Shutdown System

5.1 Troubleshooting the Sweeping System

Problem	Possible Cause	Remedy
Loss of Vacuum or Not Picking Up Debris	Sweeping too fast	Slow down
	Auxiliary engine speed too low	Increase auxiliary engine speed
	Head not fully lowered	Lower head completely
	Skid plates out of adjustment	Adjust skid plates
	Worn pickup head flaps	Replace flaps
	Faulty seal (fan, intake or door)	Replace Seal(s)
	Torn hose(s)	Replace hose(s)
	Improper head spring tension	Adjust head spring tension
	Bent or uneven drag arms	Straighten or replace drag arm
	Blast orifice too wide	Be sure orifice is roughly 1'
	Blast orifice blocked	Remove blockage from opening
	Blocked intake inlet	Remove hose and clean debris from intake inlet
	Blocked screen	Remove blockage
	Blocked intake tube	Remove blockage
	Loose drive belt	Tighten belt
	Low auxiliary engine rpm	Seek service
	Bleeder door open	Close bleeder door
	Worn Fan	Replace fan
	Fan not located properly within fan housing	Adjust fan or back plate
	Holes in hopper or fan housing	Repair holes
Blast orifice distance to pickup head incorrect	Adjust skids	
Excessive Runner Wear or Head Not Gliding Properly	Improper head spring tension	Adjust head spring tension
	Bent or uneven drag arms	Straighten or replace drag arms
	Improper side plate adjustment	Adjust side plates
	Bent head channel	Straighten or replace head channel
Head Drifting Down	Leaking pickup head cylinder seal	Rework seals
	P. O. check valve stuck open	Replace or clean
Unusual Noise or Vibration	Worn bearings	Replace bearing(s)
	Fan out of balance	Clean debris, re-balance or replace fan
	Fan shifted within housing	Reposition fan
	Loose drive belt	Tighten drive belt
	Loose bolts	Tighten bolts
	Fan blades worn or broken	Replace fan
	Loose shaft bearing bolts	Tighten bolts

5.2 Troubleshooting the Auxiliary Engine

Problem	Possible Cause	Remedy
Auxiliary Engine Will Not Start	Dead Battery	Charge or replace battery
	Bad starter solenoid	Replace solenoid
	No power to console	Find break in wire, reconnect, Check breaker
	No power to engine	Check plug at front of auxiliary engine connecting the engine wiring harness to main sweeper harness
	No power to shutdown solenoid	Check engine module wiring
	No fuel	Fill fuel system
	Improper starting procedure	Review Section 4 - Operations
	Loose battery connector	Tighten connector
Any Additional Symptoms	Please see the John Deere manual	

5.3 Troubleshooting the Water System

Problem	Possible Cause	Remedy
No Water Exiting Pump	Out of water	Refill tank
	Suction line clogged	Clean 'Y' strainer
	Air leak in line	Tighten plumbing
	Pump shaft not turning	Check motor and electrical circuit
One Spray Nozzle Not Working	Clogged strainer at nozzle	Clean or replace nozzle strainer
	Crimped or clogged water line	Un-crimp or unclog line
	Nozzle valve not on	Switch nozzle valve on
Only One Spray Nozzle Working	Clogged stainer at nozzle	Clean 'Y' and then clean or replace nozzle strainer
	No water	Refill water system
	Wiring on solenoid	Check power wire and ground, repair as needed
	Bad solenoid	Replace solenoid
Low Pressure	Worn nozzle	Replace with nozzle of proper size
	Air leak in inlet plumbing	Disassemble, reseal and reassemble
	Relief setting too low	Adjust relief valve on pump.
Water Draining From Nozzle When Off	Leaking valve	Clean valve
Any Additional Symptoms	Please see the water pump manual	

5.4 Troubleshooting the Hydraulic System

Problem	Possible Cause	Remedy
Extreme Heat, Unusual Noise, or Poor Performance From The Pump	Reservoir cap is not vented	Replace cap with vented equivalent
	Dirty Hydraulic oil	Remove filters and clean or replace; change oil
	Low oil level	Check oil and fill as needed.
	Bad pump	Repair or replace pump
	Bad hydraulic motor	Rebuild or replace motor
Hydraulic System Will Not Operate	Mechanical pump not being powered	Engine must be operating; determine reason pump is not being driven and repair accordingly
	Directional valve faulty or has poor ground	Check electrical components or replace valve
	Major leak in hydraulic system	Repair leak
	Hydraulic pump pressure too low	Adjust pump pressure (relief valve in manifold)
	Leaking cylinders seals	Replace seals or seek service
Dump System Doesn't Start Function Properly	One arm tries to get ahead of the other	Bleed entrapped air from the front and rear lift cylinders when hopper and tilt is seated down. Adjust counterbalance valves on lift cylinders to match pressure setting shown on schematic.
	Dump door does not open evenly	Adjust counterbalance valves on door cylinders to match pressure settings shown on schematic.

NOTE Adjust the pressure setting (release pressure) on counterbalance valves.

IMPORTANT Clockwise reduces pressure setting. Counterclockwise increases pressure setting. The two relief valve cartridges in the dump sequencing manifold must be balanced at 2750 psi setting.

5.5 Troubleshooting the Side Brooms

Problem	Possible Cause	Remedy
Broom Disc Spins too Slow	Sweeper engine speed too low	Increase sweeper engine speed to speed up broom
	Fluid viscosity is too high for operating temperature	Replace with lighter weight oil
	Outside temperature too low	Run auxiliary engine longer before use
	Broom hydraulic motor is bad	Rebuild or replace motor
Broom Hits Frame	Too much down pressure	Adjust down pressure
	Inner broom cylinder stroke is too short	Screw rod end toward cylinder to lengthen stroke
Debris Trails Between Broom Disc & Pickup Head	Spring tension too light	Adjust spring tension
	Improper broom tilt adjustment	Adjust broom tilt
	Broom arm with GEO extended too far	Adjust GEO
Broom Disc Stalls in Heavy Debris	Broom bristles worn	Replace broom bristles
	Pressure to broom motor too low	Adjust relief pressure
	Sweeper engine speed too low	Increase sweeper engine speed to speed up broom (see section 4 - Operations)
	Motor or pump seal leaking	Seek service
Broom Flings Debris Back Into Gutter	Too much down pressure	Adjust down pressure (see section 4 - Operations)
	Broom disc tilt angle adjusted too flat	Adjust broom disc tilt angle
Broom Flings Debris Across Street	Tilt angle of broom head too great	Adjust broom head
	Center flap worn or damaged	Replace flap
Broom Spins But Will Not Extend/Retract	The inside of the cylinder's hydraulic hose or fitting is blocked	Clear blockage
	Directional valve malfunctioning	Check directional valve. Replace if needed.
	Lock valve not functioning	Clean or replace valve
Broom Operates But Will Not Lift	Switch or directional valve wire loose or bad connection	Check wiring.
	Block solenoid valve	Replace valve
	Leaking cylinder seals (fluid loss out of port)	Replace seals
	Mechanical bind	Check broom hardware for binds
Broom Spins But Will Not Lower	Solenoid valve's electrical circuit incomplete	Complete circuit
	Bad solenoid valve cartridge (Lock Valve)	Replace cartridge
	Mechanical bind	Check broom hardware for binds
Broom Raises But Leaks Down Immediately	Solenoid valve stuck open (Lock Valve)	Clean valve or replace
	Leaking cylinder seals (fluid loss out of port vent)	Replace seals
Broom Operates But Disc Does Not Spin	Bad broom motor	Service or replace motor

	Directional valve not operating	Repair or replace directional valve
Broom Drops But Will Not Otherwise Operate	Directional valve's electrical circuits incomplete	Complete circuit
	Directional valve ports blocked	Seek service
	Bad pump or motor	Service or replace pump or motor

5.6 Troubleshooting the Camera System

For camera system troubleshooting, see the camera system manufacturer's Owner's Manual, which is provided with this manual set.

5.7 Troubleshooting the Automatic Shutdown System

For troubleshooting the automatic shutdown system, see the John Deere Manual

Section 6 - Service

Servicing your Schwarze sweeper

In this part of the manual we include checking, adjustment and/or replacement procedures for all major sweep systems and devices

For some systems and components maintenance is regular and ongoing. For others, we include a beginning statement to tell you when adjustment or replacement is necessary.

For many components, we also include a table of maintenance tasks.

⚠ DANGER Never operate, or perform maintenance to, the sweeper while wearing loose fitting clothing. Entanglement of loose clothing with the rotating elements can result in serious injury or death. Stay clear of all rotating elements at all times.

⚠ WARNING Always turn on all safety lights and flashers when servicing the sweeper.

6

In this Section

Oil Levels and Lubrication

Pickup Head Adjustment & Replacement

Hopper Replacement & Installation

Side Brooms Adjustments & Replacement

Servicing the Power Module

Dust Suppression System Cleaning & Winterizing

Electrical System Maintenance

6.1 Oil Levels and Lubrication

Auxiliary Engine Oil

Refer to your auxiliary engine Owner's Manual for the manufacturer's suggested oil type and oil change schedule. To drain the engine oil pan, use the engine oil drain hose. This hose, which resembles the hydraulic hoses, runs from the center of the oil pan, out the right side of the engine skid and is usually looped around to the front of the engine skid for storage. By unscrewing and removing the JIC plug in the end of the hose, the oil may be drained into a container. Be sure to dispose of the used oil properly, recycling it if possible.

Auxiliary Engine Cooling System

Refer to your auxiliary engine Owner's Manual for cooling system care and maintenance. When replacing your engine's coolant, be sure to dispose of the old coolant properly.

Hydraulic System

The hydraulic oil level should be maintained such that it is kept at the full mark as measured with the hopper down, brooms up and the pickup head in the up position. Check by using the sight level gauge, which is located on the left side of the reservoir. Change the hydraulic oil and filter after the first 500 hours of operation, then every 2000 hours thereafter.

If the hydraulic fluid becomes cloudy, water has contaminated the system and the hydraulic fluid needs to be changed (after determining the source of the water contamination and correcting it). If the sweeping unit is operated in particularly dusty conditions, the hydraulic filters will need to be changed more often.

Lubrication Schedule

Item	Frequency	Lubrication
Dump Door Hinges	Monthly	Grease with lithium-based grease.
Hopper/Frame Hinge	Monthly	Grease with lithium-based grease.
Side Broom Arm U-Joint	120 Hours of Operation	Grease with lithium-based grease.
Fan Shaft Bearings	250 Hours of Operation	Grease with lithium-based grease, one pump from a hand-operated gun. DO NOT OVER-GREASE OR USE A POWER GUN

Item	Frequency	Lubrication
Fan Seal, Intake Seal, and Rear Door Seal	As Required	Lubricate with a rubber protector or grease to prevent drying and loss of resilience.
Leaf Bleeder Door	Monthly	Grease with lithium-based grease.

Fan Shaft Bearing Lubrication

The two pre-lubricated bearings on the fan shaft should be re-lubricated after 250 hours of operation (check the sweeper engine's hour meter and the lubrication chart). Use a lithium-based grease conforming to NLGI Number 2 consistency. It must be free from chemical impurities such as free acid and free alkali, as well as physical impurities such as dust, rust, metal and other abrasive particles. This light-viscosity, low-torque grease is selected because of its water-insoluble rust inhibitors and operating temperatures that make it chemically and mechanically stable. Its normal operating temperature range of -30° to +200° Fahrenheit is ideal for sweeper operations. However, it can operate intermittently at temperatures of up to +250° Fahrenheit, providing maximum bearing protection.

IMPORTANT Always use a hand-operated grease gun to grease the bearings.

Use only one pump of grease or until a small bead forms around the bearing seal. This bead acts as an indicator of adequate lubrication and provides a protective seal which prevents foreign material from entering the bearing where it would damage the races. There is generally a slight rise in operating temperature (10-30° Fahrenheit) after re-lubricating the bearing. This temperature rise will continue until the grease stabilizes in the bearing chamber.

Lubrication

1. Prior to lubricating, run the auxiliary engine in order to heat up the old grease. When the bearing grease has warmed, turn the auxiliary engine off and remove the keys.
2. Using a hand-operated grease gun, slowly apply one pump of grease to the bearing (equivalent to approximately 1/4 ounce of grease) or until a slight bead forms around the bearing seals.

IMPORTANT Never use more than one pump of grease, and do not grease the bearings more often than every 250 hours of operation. Over-greasing the bearing will cause the bearing to overheat and fail.

IMPORTANT Lubrication should never differ from the prescribed procedure or schedule. Bearing life is shortened by over-lubrication - either by greasing too frequently or too excessively.

6.2 Pickup Head

The pickup head is dependent upon forced air and vacuum to achieve debris pickup. Without proper maintenance and replacement of parts due to normal wear, the pickup head cannot provide the desired sweeping results.

Replacing the Skid Plate

Replace the skid plate when its runner is 80% worn through.

Removal/Replacement:

1. Locate the skid plates on either side of the pickup head.

NOTE

Studs, welded to the pickup head, protrude through slots in the skid plates. The skid plates are held in place against the head by the nuts and washers on these studs.

With the pickup head raised, remove the skid plate's nuts and washers and set them aside for later use.

Pull the old skid from the side of the pickup head and replace it with the new skid plate.

2. Remount the nuts and washers that were removed earlier. Screw them down against the skid plate, but do not tighten them until the new skid plate is in the proper position.

When skid plate adjustment is necessary, the blast orifice must remain 2" to 2-1/2" from the sweeping surface. Less than 2", and the air stream becomes choked down. More than 2-1/2" and the blast velocity of the air striking the sweeping surface is lost.

IMPORTANT Never adjust the skid plates to extend the life of the flaps. When the flaps can no longer maintain a satisfactory seal, they should be replaced. Adjusting the skid plates instead will affect the sweeping efficiency due to the change in blast orifice-to-ground distance.

Adjustment

1. Raise the pickup head and locate the skid plates on either side.

2. Loosen the 5/8" nuts on each of the pickup head skid plates.
3. Slide each skid plate up or down its slots to achieve the required blast orifice-to-sweeping surface distance.
4. Re-tighten the 5/8" nuts on each pickup head skid plate.
5. Lower the pickup head and make sure that the skids are riding flat on the sweeping surface. Adjust as needed.

Seasonal Pickup Head Adjustments

The pickup head's orientation to the sweeping surface may be manipulated to maximize performance in various seasonal conditions.

By adjusting the leading ends of the skid plates further up than their trailing ends, the pickup head can be set to minimize frontal area. This is often preferable during heavy cleanup periods, such as in the spring cleanup season. Adjustment in this manner provides a faster channel of air/debris mixture and less distance that the debris must move.

By adjusting the trailing ends of the skid plates further up than their leading ends, the pickup head can be set to maximize frontal area. This is especially helpful during the fall season when leaves must be swept.

IMPORTANT

Prolonged usage with previous adjustments will reduce the life of the flaps. When the flaps can no longer maintain a satisfactory seal, they should be replaced.

Adjusting the Pickup Head Tension Spring

Near the four corners of the pickup head are the pickup head tension springs. These springs help the pickup head 'float' above the sweeping surface.

Over time these springs can lose their tension and adjustments need to be made. When skid adjustments are made, most likely the tension of the springs will also have to be adjusted.

Too little spring tension shortens runner life. Too much spring tension can cause the pickup head to bounce on irregular surfaces, resulting in loss of suction.

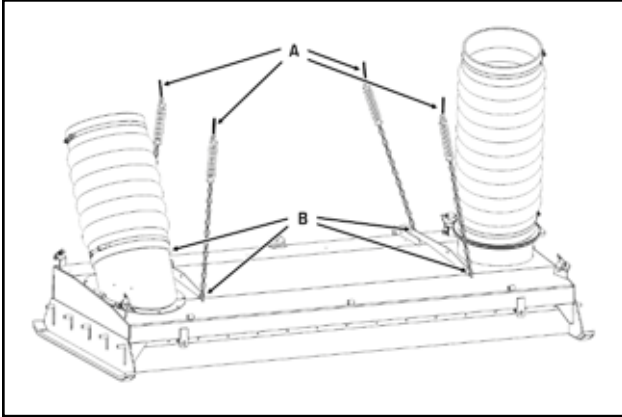

- A Fine Adjustments
- B Coarse Adjustments

Fine Adjustment

1. Locate the eye bolt that connects the head spring to the frame.
2. Loosen or tighten the nut on the end of each eye bolt to raise or lower the head.

Coarse Adjustment

1. Raise the pickup head.
2. Unhook the chains from the springs or remove the 5/16" bolts that hold the spring chains to each side of the head.
3. Increase or decrease the number of chain links between the head retainers and the ends of the head springs as needed.

Replacing the Pickup Head

Removal

1. Raise the pickup head.
2. Unhook the chains from the springs or remove the 5/16" bolts that hold the spring chains to each side of the head.
3. Lower the pickup head and loosen the lower hose clamps on each side of the pickup head.
4. Remove the lower ends of the intake and exhaust hoses.
5. Remove the 3/8" bolts that hold the pickup head lift cylinder chains to each side of the pickup head.
6. Disconnect the water hoses that run down the drag arm from the hose barb of the first in-line spray nozzle on the pickup head, and the hose barb of the intake tube.
7. Remove the 7/8" drag arm bolts.
8. Unbolt the side brooms' center drag flap from the front of the head.
9. Slide the pickup head out from underneath the truck.

Installation

1. Slide the pickup head underneath the truck.
2. Bolt the side brooms' center drag flap to the front of the head.
3. Install the 7/8" drag arm bolts.
4. Connect the water hoses.
5. Install the 3/8" bolts that hold the pickup head lift cylinder chains to each side of the pickup head.
6. Connect the lower ends of the intake and exhaust hoses.
7. Fasten the lower hose clamps on each side of the pickup head and raise the pickup head.
8. Hook the chains to the springs or install the 5/16" bolts that hold the spring chains to each side of the head.

Replacing the Pickup Head Flaps

When new, the pickup head flaps will extend past the bottom of the skid plate. With use, these will wear until they hang straight down and lose contact with the ground. When this occurs, it is time to replace the flaps.

Replacement

On the underside of the pickup head are four flaps of different sizes. The positioning of each flap is designed to produce the maximum performance from the pickup head. To ensure proper flap placement, replace one flap at a time.

1. Remove the pickup head by following the head removal steps of section '6.2.3 Replacing the Pickup Head
2. Turn the pickup head upside down.
3. Remove the 1/4" bolts which hold the metal backing strips and the flap to the pickup head.
4. Install the new flap and metal strips.

While the pickup head is upside down, also check the blast orifice for objects or blockage in the opening and clean as needed. Check the blast orifice opening for damage or deformity from impact of objects on the sweeping surface.

Even with the pickup head adjusted to the proper height, the new flaps will still hang below the bottom of the runners on the skid plates. Lower the pickup head onto a level surface and check the skid plate adjustment. If the skid plate adjustment seems correct, start the sweeper and check the head flaps for proper sealing and adequate pickup.

Adjusting the Pickup Head Blast Orifice

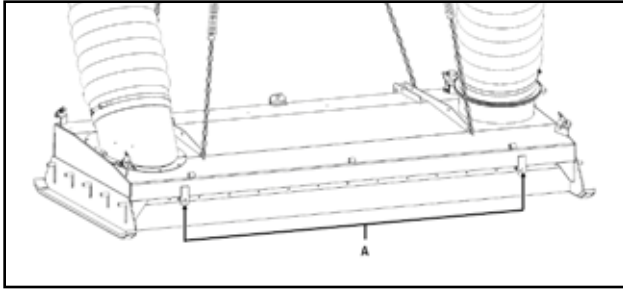

A Blast Orifice Adjustment Jackscrews

The blast orifice is set at the factory at a width of 1". However, some operators prefer it a little wider (creating less blast force) or narrower (creating more blast force). It should be noted that too much variance from the standard 1" width will reduce sweeping efficiency.

1. Locate the two jackscrews along the rear edge of the pickup head.
2. To adjust the blast orifice width, turn the hex head of the jackscrews clockwise to open the orifice and counterclockwise to narrow it.

Replacing the Pickup Head Hoses

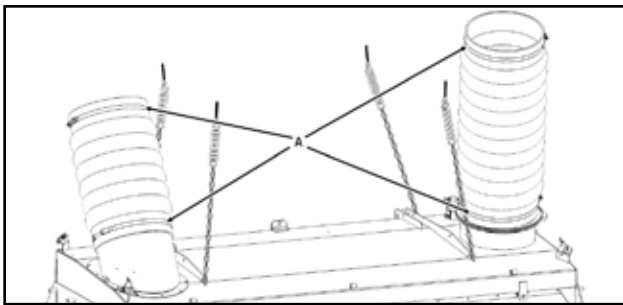

A Pickup Head Hose Band Clamps

To extend the life of the intake and exhaust hoses, periodically (3 or 4 times a year) rotate each hose.

1. Unscrew the band clamps at the top and bottom of the hose to be removed. Insert a screwdriver between the hose and the housing if needed.
2. Once loose, slide off the hose, and replace it with a new one.
3. Put the band clamps back in place and tighten them.

6.3 Hopper

The hopper is a simple component and needs little in the way of maintenance. Clean the hopper daily to prevent debris build-up and follow the lubrication schedules.

Replacing the Hopper Seals

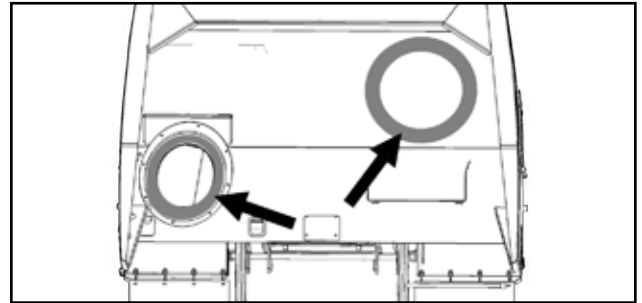

It is important that the sweeper's seals on the fan housing be kept in the best condition possible. These include the seals on the suction hose inlet, around the hopper's inspection door opening and on the rear door. Pickup power is vacuum dependent, so a tight seal can make a significant difference in pickup ability. Maintain resilience by keeping the seals well lubricated with a good grade of petroleum-based jelly or grease.

NOTE

Lubrication of the side inspection door seals is not necessary.

For longer seal life, when the sweeper is parked for an extended period of time, leave the dump and all inspection doors open and raise the hopper a few inches so their seals can regain their shape.

Eventually the seals will become worn or non-resilient and must be replaced.

Replacement

1. Use a gasket scraper, putty knife or screwdriver to remove the seal from its sweeper component. Get the metal surface as clean as possible. Be sure it is free of all dirt, old glue, and seal material.
2. Liberally apply a coat of weather-strip-type adhesive onto the new seal and body component. Allow the adhesive to set up for several minutes (follow the adhesive manufacturer's instructions) and then put the new seal in place.

Replacing the Hopper

Needed for a hopper replacement:

- Two workers
- Overhead crane
- Support blocks

Removal

1. Install approved lifting eyes and load spreader if needed in the two front lifting eye positions.
2. Raise the hopper and insert the safety props.
3. Remove the pins from the tilt cylinders at the hopper floor. The cylinders are heavy. Use caution when removing the pins and lowering the cylinders into the hopper frame.
4. Remove and Label hoses, electrical wiring, and hydraulic connections that will remain with the hopper.
5. While supporting the hopper in the raised position with an approved overhead crane, remove the safety props and lower the hopper.

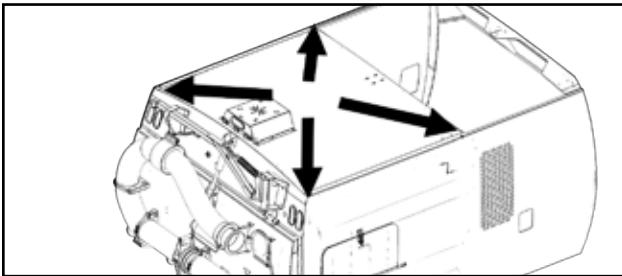

6. Affix approved lifting eyes and load spreader if needed to all 4 lifting eye positions and lift to de-weight the hopper.
7. Remove the two rear tie pins and lift the hopper straight up.

Installation

- Reverse above procedure

NOTE

If your sweeper is equipped with the optional Auto Lube System, actuate the system to assure the lubrication points have received lubrication prior to the timer setting.

6.4 Side Broom(s)

The following sections deal with adjustments and replacement of mechanical portions of the side broom.

Adjusting the Manual Side Broom Tilt

If the side broom is not throwing debris into the pickup head path correctly, the broom pattern can be improved by adjusting one or both axis (the side-to-side and forward/rearward tilt) of the side broom.

Forward / Rearward Tilt

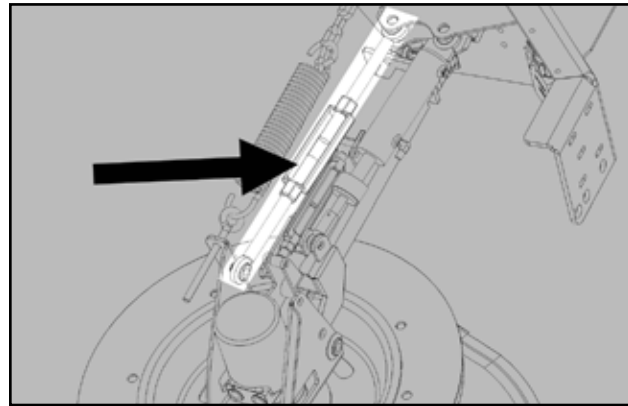

Forward/rearward tilt is controlled by a turnbuckle located between the broom arm mounting bracket and the top of the broom motor mount

CAUTION Never work on or near the side broom when the side broom is rotating.

1. With the auxiliary engine stopped, turn the auxiliary engine key switch to ON, but do NOT start the engine.
2. Toggle the side broom cab console control switch on.
3. Locate the large turnbuckle located between the side broom mounting bracket and the side broom motor mount.
4. Loosen the jam nut on the turnbuckle.
5. Insert a large screwdriver or wrench into the center of the turnbuckle to use as leverage.
6. To lower the nose of the side broom disc, lengthen the turnbuckle by turning the center clockwise.
7. To raise the nose of the side broom disc, shorten the turnbuckle by turning the center counterclockwise.
8. Run the jam nuts tight against the turnbuckle to lock the readjustment.

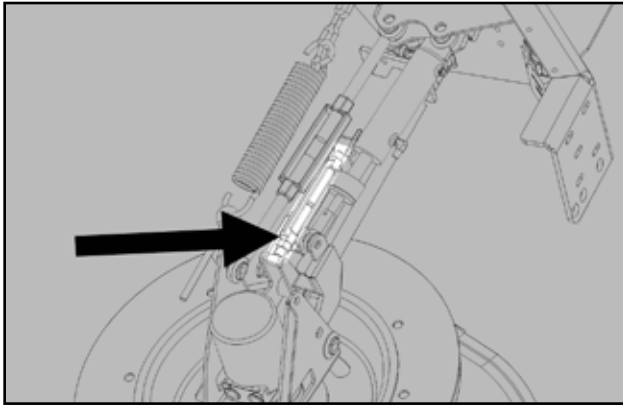
Side-To-Side Tilt

Side-to-side tilt is controlled by a smaller turnbuckle located between the broom pivot and the rear of the broom arm.

CAUTION Never work on or near the side broom when the side broom is rotating.

1. Start the auxiliary engine.
2. Run the side broom to its extended sweeping position.
3. Stop the side broom disc rotation.
4. Locate the small turnbuckle located in the side broom arm.
5. Loosen the jam nut on the turnbuckle.
6. Insert a large screw driver or wrench into the center of the turnbuckle to use as leverage.
7. To increase the tilt of the side broom disc, lengthen the turnbuckle by turning the center clockwise.
8. To decrease the tilt of the side broom disc, shorten the turnbuckle by turning the center counterclockwise.
9. Run the jam nuts tight against the turnbuckle to lock the readjustment.

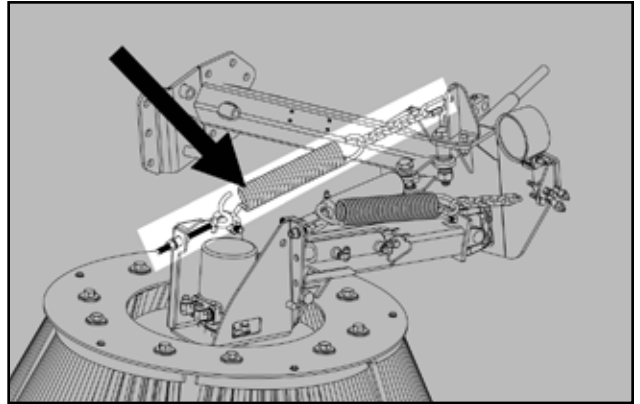
Adjusting the Manual Side Broom To Pavement Contact/Down-Pressure

Optimum down-pressure ensures good sweeping performance. Lighter debris may require less down-pressure. Heavier material, such as soil or millings, may require more 'digging' pressure from the broom.

CAUTION Never work on or near the side broom when the side broom is rotating.

1. With the broom in the up position, locate the nut holding the eyebolt to the motor-mount angle bracket.
2. Thread the nut all the way out to the end of the eyebolt.
3. Remove or add chain links as desired between the eyebolt and spring.
4. Screw the eyebolt nut about 1-1/2 inches up the eyebolt.
5. Start the auxiliary engine.
6. Lower and run the side broom.
7. As the broom runs, observe the bend in the broom bristles to determine whether down-pressure should be increased or decreased.
8. Stop the broom.
9. Turn off the auxiliary engine.
10. If down-pressure should be INCREASED, loosen the eyebolt nut by threading it further down the eyebolt.
11. If down-pressure should be DECREASED, tighten the eyebolt nut by threading it further up the eyebolt.

Adjusting the Side Broom Extension Spring

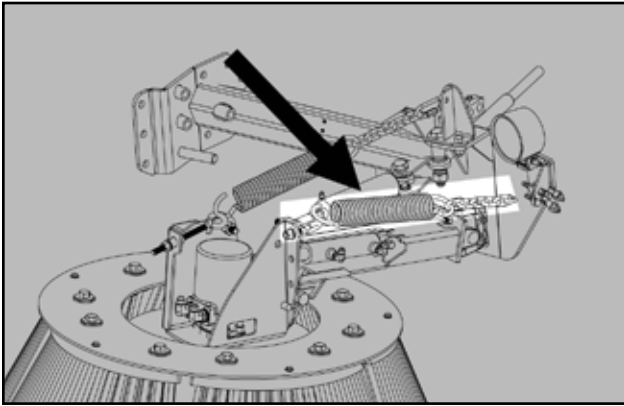

The side broom extension spring controls the side broom arm extension speed and travel. Located to the outside of the side broom arm, this spring is connected to the side broom mounting bracket by a chain at one end. The spring's other end is attached to a large eyebolt fastened to the side broom motor mount.

The side broom extension spring may need adjustment when:

- The broom doesn't fully extend during operation
- Travel speed is too slow

You control the side broom arm extension speed and travel by adjusting:

- Extension spring tension
- Attitude of the chain

CAUTION Never work on or near the side broom when the side broom is rotating.

1. With the broom in the up position, locate the extension spring.
2. Locate the row of slots in the side broom mounting bracket's outer plate.
3. To DECREASE chain attitude, move the chain to a slot closer to the outer plate.
4. To INCREASE chain attitude, move the chain to a slot further away from the outer plate.
5. To INCREASE tension, remove links from the chain and/or adjust the eyebolt on the side broom motor mount.
6. To DECREASE tension, add links to the chain and/or adjust the eyebolt on the side broom motor mount.

Adjusting the Side Broom Hydraulics

The only hydraulic adjustment that may be necessary concerns return speed. Return speed is controlled by a flow control cartridge valve on a small valve block, fastened to the main valve.

You open or close this flow control cartridge valve to adjust hydraulic return speed, turning it clockwise to slow the return speed and counterclockwise to increase the return speed.

Side broom hydraulic speed may need adjustment when the side broom:

- Does not retract.
- Retracts too fast.
- Retracts too slowly.

CAUTION Never work on or near the side broom when the side broom is rotating.

1. Start the sweeper and run the side broom for about 5 minutes.
2. Check the sight gauge on the hydraulic tank.
3. Continue to run the side brooms until the hydraulic-fluid temperature has reached 80° degrees
4. Turn off the sweeper and the side broom.
5. Locate the flow control cartridge valve on the small valve block fastened to the side broom mounting bracket. The flow control cartridge valve protrudes from the bottom of the valve block.
6. Loosen the jam nut that secures the stem of the flow control cartridge valve.
7. Restart the sweeper and broom.
8. Run the broom at normal rpm.
9. Observe the return speed as you lower and raise the side broom. The return speed should be between 1-1/2 and 3 seconds.

CAUTION Never adjust the flow control cartridge valve when the side broom is turning. Always stop the side broom before attempting to adjust the control flow cartridge valve.

10. Turn off the broom
11. If the return speed was too slow, increase the flow by inserting an Allen wrench into the end of the valve's stem and turning counterclockwise.
12. When return speed is between 1-1/2 and 3 seconds, run the jam nut back against the valve's main body to secure the valve stem in place.

Adjusting/Replacing the Side Broom Cylinder

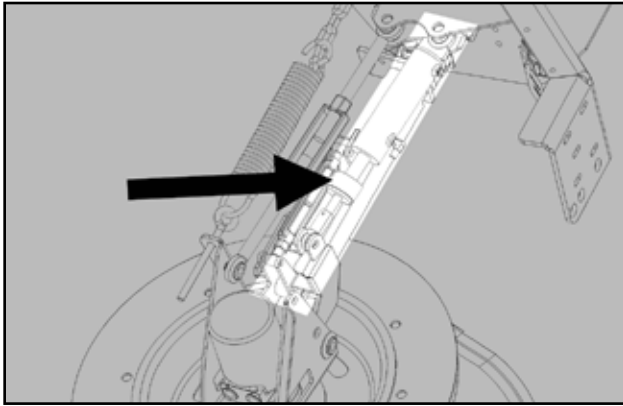

Adjustment

CAUTION Never work on or near the side broom when the side broom is rotating.

1. With the auxiliary engine stopped, turn the auxiliary engine key switch to ON, but do NOT start the engine.
2. Turn on the side broom.
3. When the side broom is extended to its normal operating position, turn it off.
4. Locate the rod end on the cylinder's extension rod.
5. Screw the jam nut away from the cylinder's rod end.
6. Grasp the painted portion of the rod with a pair of channel-lock pliers.
7. To increase the inward and upward distance the side broom will travel when retracted, adjust the rod end to shorten the cylinder.
8. To decrease the inward and upward distance the side broom will travel when retracted, adjust the rod end to lengthen the cylinder.
9. Run the jam nut tight against the cylinder's rod end to lock the readjustment.

Replacement

1. Start the auxiliary engine and run the side broom.
2. When the side broom is extended to its normal operating position, turn it off.
3. Turn the auxiliary engine key switch back ON, but do NOT start the engine.
4. Move the side broom control switch up and down several times. Doing so relieves any back pressure in the cylinder, making removal easier.
5. Disconnect the hydraulic hose from the cylinder.
6. Remove and set aside hydraulic fittings from the cylinder ports.
7. Remove the bolt at the rod end of the cylinder and set it aside.

8. Remove the bolt at the base of the cylinder and set it aside.
9. Pull the cylinder from the broom arm.
10. Unscrew the rod end and jam nuts from the cylinder to be replaced.
11. Attach the rod end and jam nuts just removed to the new cylinder.
12. Position the new cylinder on the broom and bolt it into place.
13. Taking care to place the vented plug in the butt-end port, attach the previously set aside hydraulic fitting to the new cylinder.
14. Reattach the hose to the rod and fitting.

Replacing the Side Broom Motor

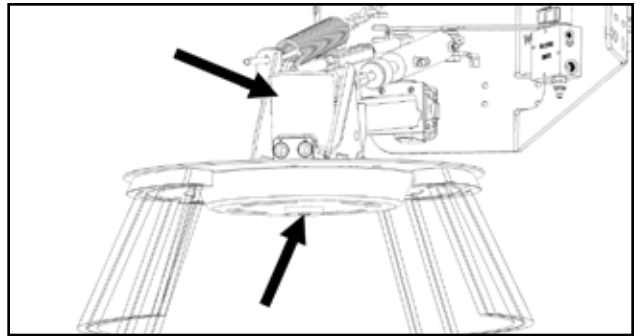

CAUTION Never perform service on the side broom motor while the auxiliary engine is on.

Disassembly

1. With the side broom in the raised position, remove a side broom segment
2. Reaching under the side broom, loosen the large nut at the end of the side broom motor shaft until the gap between the nut and the shaft is about 1/4 inch.
3. Insert a pry bar between the side broom motor mount and the side broom disc, and pry the disc from the motor mount. Tap on the side broom disc with a hammer if needed.
4. Position a floor jack under the side broom disc to raise the disc above the side broom motor shaft nut.
5. Remove the side broom motor shaft nut
6. Let down the jack.
7. Remove the side broom disc from the side broom motor shaft
8. Label which hydraulic hose is attached to which side broom-motor port.
9. Remove the two side broom motor hoses
10. Remove the four side broom motor mounting bolts

11. Remove the old side broom motor.
12. Remove hydraulic fittings from the old side broom motor

Replacement

1. Install the new side broom motor onto the side broom motor mount.
2. Attach the previously labeled hydraulic hoses to the correct labeled ports and reconnect hydraulic fittings.
3. Use the floor jack to raise the side broom disc while positioning it under the side broom motor.
4. Locate the key in the keyway of the motor shaft.
5. Raise the side broom disc into position, aligning the key with the broom disc keyway.
6. When the side broom disc is in correct position, screw the side broom motor shaft nut onto the end of the shaft.
7. Tighten the side broom motor shaft nut.
8. Replace the missing side broom segment.
9. Turn on the auxiliary engine.
10. Turn on the side broom.
11. Check the side broom pattern and adjust as needed.

Replacing the Side Broom Tilt Cylinder

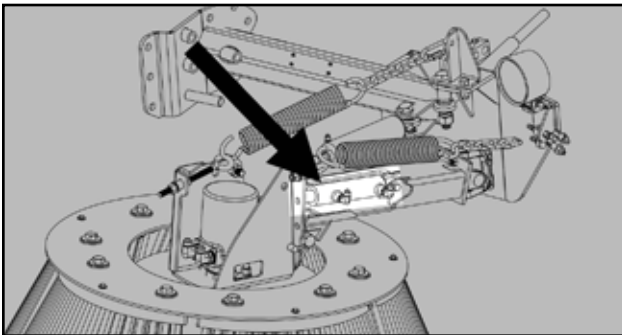

CAUTION Never work on or near the side broom when the side broom is rotating.

Disassembly

1. Start the auxiliary engine and turn on the side broom.
2. When the side broom is lowered, turn it off.
3. Locate the cylinder bolted to the pivot.
4. Remove the two bolts at either end of the cylinder. It may be necessary to manually wiggle the broom disc to rock the pivot so you can work the bolt loose
5. Disconnect the two hoses from the cylinder.

Replacement

1. Connect the two hoses to the replacement cylinder.
2. Use the two bolts to install the replacement cylinder.

Replacing the Side Broom Bristles

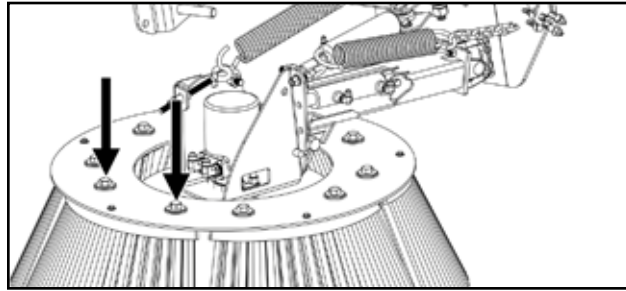

Side broom bristles should be replaced when they are worn to approximately 6 inches in length. When side broom bristles are allowed to wear shorter, the bristles become too stiff and lose their ability to flick debris.

CAUTION Never work on or near the side broom when the side broom is rotating.

1. With the side broom in the raised position, locate the most accessible side broom bristle segments.
2. Remove the bolts that hold the first side broom bristle segment to the side broom disc.
3. Position the new side broom bristle segment and replace the bolts holding it to the side broom disc.
4. Repeat steps 2 and 3 for other accessible side broom bristle segments.
5. Start the auxiliary engine.
6. Run the side broom until other side broom bristle segments are accessible for replacement.
7. Turn off the auxiliary engine.
8. Repeat steps 2 through 6 to expose and replace all side broom bristle segments.

6.5 Power Module

Because of the nature and operation of a sweeping machine, it is recommended that servicing of the filters, changing oil and other routine preventive maintenance functions be performed somewhat more frequently than recommended by the manufacturer of the engine.

Auxiliary Engine Filters

The auxiliary engine has three filters: a fuel filter, an oil filter and a dual element air filter. At a minimum, all filters should be changed according to the engine manufacturer's warranty recommendations. We recommend that the oil filter be changed more often if the sweeper is operated under unusually dusty circumstances.

The air filter has a built-in air restriction indicator. When the air filter becomes clogged and needs service, a window on the air restriction indicator changes color. Depending upon the type of air restriction indicator used, this color change may be from clear to red, clear to yellow or yellow to red. The air restriction indicator is normally located on or near the auxiliary engine's air filter canister or optionally by remote in the truck cab on the console.

IMPORTANT

Do not clean air filter with high pressure air. Clean or change the air filter only when the air restriction indicator's 'Need to Service' window has changed colors. Serious engine damage can occur as a result of air cleaner overservicing.

For air filter change and service information, please see the Owner's Manual for the auxiliary engine.

Replacing the Engine Stub Shaft

Stub shaft failures are rare but may, at some point, need to be replaced. Causes for stub shaft failure include; too much side-load created by a too tight drive belt, grooving or warping of the stub shaft by a failed bearing and stub shaft cracking or warping due to torque created by the sudden stop of the fan's drive train. In addition, we suggest that the stub shaft be replaced whenever the auxiliary engine is changed.

Replacement

1. Remove the sweeper engine's keys and/or disconnect the battery cable to prevent the sweeper engine from being started accidentally.
2. Loosen the belt tension as outlined in the 'Drive Belt Tension Adjustment' section.
3. Turn the jackscrew nuts so the engine skid is pushed toward the fan shaft.
4. As the engine skid moves toward the fan shaft, the drive belt will become loose enough to be slipped from its pulleys.
5. Remove the three 3/8" bolts and lockwashers from the stub shaft pulley bushing.
6. Insert two of the 3/8" bolts into the two tapped holes of the stub shaft pulley bushing.
7. Tighten the bolts evenly, alternating from one to the other. This will push the pulley off the stub shaft pulley bushing.
8. Remove the pulley and its bushing from the stub shaft.
9. Remove the bearing plate from the end of the auxiliary engine bell housing. Inspect the plate for irregularities. If none are found, the bearing plate may be used again.
10. Remove the old stub shaft from the end of the auxiliary engine.
11. Clean the flywheel and replacement stub shaft using lacquer thinner.
12. Fasten the replacement stub shaft to the auxiliary engine using 60 ft. lbs. of torque on each bolt.
13. Use a dial indicator and ensure that the stub shaft is in-line with the crankshaft. The stub shaft must be no more than .008" off-center.

IMPORTANT

If the stub is more than .008" off-center, it should be replaced.

14. Place the replacement bearing onto the end of the shaft. Using a piece of pipe placed over the stub shaft's end, drive the bearing down the stub shaft until it rests against its seat.
15. Slip the bearing plate down the stub shaft and onto the bearing.
16. Bolt the bearing plate too the auxiliary engine.
17. Slide the stub shaft pulley and its taper-lock bushing onto the end of the stub shaft.
18. Insert the bolts through the taper-lock bushing onto the end of the stub shaft.
19. Check the alignment of the pulleys, using a string or straight edge, from the face of one pulley to the face of the other to determine whether the pulleys are in line with each other.
20. If the pulleys are misaligned, back the stub shaft pulley off its bushing, move both in the proper direction for alignment, then retighten the bushing/pulley bolts.
21. Inspect the drive belt for wear and replace it with a new one if needed.
22. Slide the drive belt onto the stub shaft and fan shaft pulleys.
23. Tighten the belt tension as outlined in the 'Drive Belt Tension Adjustment' section.
24. Replace the belt guard.

Adjusting the Drive Belt Tension

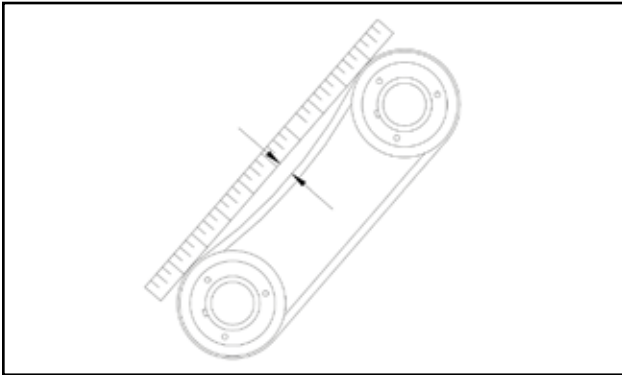

The drive belt is a belt that drives the fan shaft. Check the belt tension periodically. This is accomplished by pressing down on the belt halfway between the two pulleys. With 35- 40 lbs. of pressure (the approximate equivalent of very firm pressure from on it from your thumb), the belt should deflect about 1/2" - 3/8". An average belt, over the course of its life, will stretch slightly and the belt will need adjustment. This will be especially true during the first 75-100 hours of operation.

The auxiliary engine, along with its engine skid, can be moved in the direction of the fan shaft (to loosen or remove the belt) or away from the fan shaft (to tighten the belt).

1. Loosen the bolts that connect the two piece belt guard.
2. Loosen (but do not remove) the bolt which holds each of the four outer corners of the engine skid to the top of the power module platform.
3. Locate the threaded rods known as jackscrews.

IMPORTANT

Before adjusting the jackscrews, mark the present position of the engine skid, both at the front and rear, on the power module platform. This will allow you to determine how far the engine skid has been moved and whether the center line of the auxiliary engine is still parallel with the fan shaft.

4. Loosen the jackscrews' jam nuts.
5. By running the adjustment nuts in or out, the engine skid may be moved toward or away from the shaft. Alternate adjusting the jackscrew nuts front to rear so that movement of the engine skid is even and the engine skid does not become misaligned. If you turn the front jackscrew three revolutions, then turn the rear jackscrew three revolutions.

6. When proper belt tension is achieved, re-thread the loose adjustment nuts tightly against their power module platform tabs. (If you're adjusting the engine away from the fan shaft, these would be the inner adjustment nuts; toward the fan shaft, these would be the outer adjustment nuts.) Tighten any loose jam nuts back against their respective adjustment nuts.
7. Tighten the four tie-down bolts at the corners of the engine skid.
8. Start the sweeper engine. Squealing or abnormal vibrations indicate low belt drive tension. Adjust as needed.
9. Re-bolt the belt guard back into position.

Replacing the Drive Belt

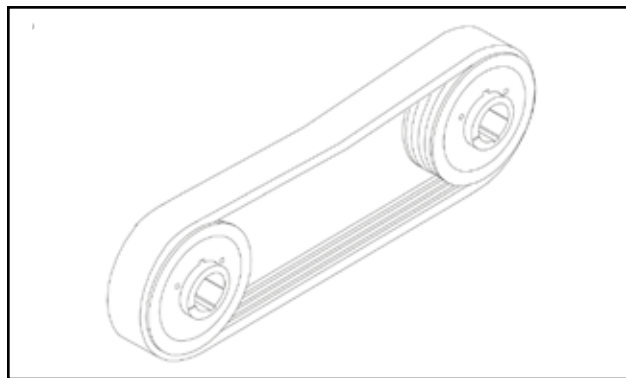

Replace the drive belt when it shows signs of wear, rather than waiting for it to break. This practice will help to ensure optimum sweeper performance and avoid downtime.

To replace the drive belt, reposition the sweeper engine.

1. Remove the sweeper engine's keys and/or disconnect the battery cable to prevent the sweeper engine from being started accidentally.
2. Follow the procedures outlined in steps 1-4 in section 'Drive Belt Tension Adjustment' of this manual
3. Loosen the mounting bolts and jackscrews so the engine skid is pushed toward the fan shaft.
4. As the engine skid moves toward the fan shaft, the drive belt will become loose enough to be slipped from its pulleys.
5. Inspect the pulley grooves for burrs and other irregularities that may cause abnormal belt wear. Replace when needed.
6. Slip the replacement belt into position.
7. Tighten the jackscrew nuts so the engine skid is pulled away from the fan shaft.
8. Continue to tighten until the belt has 1/2" deflection between the pulleys using 30 lbs. of pressure (roughly the equivalent of pressing down on the belt with your thumb).

- Check the alignment of the pulleys, using a string or straight edge, from the face of one pulley to the face of the other. This will allow you to determine whether the pulleys are in line with each other.

IMPORTANT

For slight misalignment, the pulleys may be repositioned on their respective shafts. If greater adjustment is needed than pulley repositioning can achieve, the entire engine/engine skid assembly must be moved to obtain alignment. The slotted tie-down holes of the engine skid allow a limited amount of forward & back movement.

- Once proper pulley alignment is achieved, run the jam nuts back against their respective jackscrew nuts.
- Tighten the four tie-down bolts at the corners of the engine skid.
- Start the sweeper engine. Squealing or abnormal vibrations indicate low belt drive tension. Adjust as needed.
- Re-bolt the belt guard back into position.

Inspecting the Sweeping Fan System

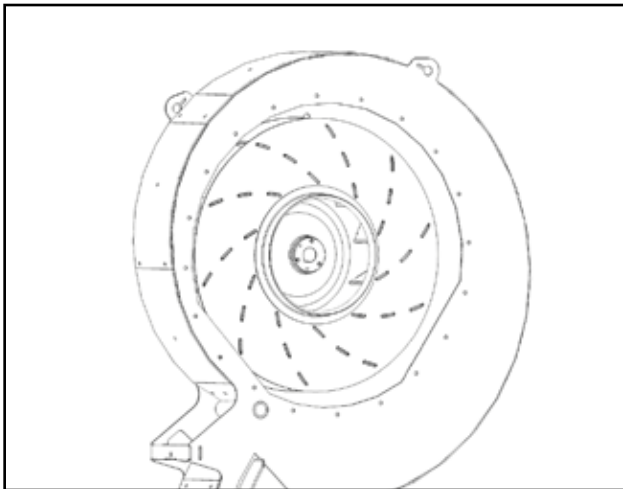

Over time, dust will cause wear to the fan house liner, fan house liner bolts and fan blades.

Inspection

- Raise the hopper and lower the safety prop into position.
- Remove the sweeper engine's keys and disconnect the battery cable to prevent the engine from starting accidentally.
- Remove the back plate.
- Using a flashlight, inspect the fan blades, fan bushing, fan housing liner bolts and the fan housing liner for wear.

- If no excess wear or abnormal wear is evident, replace the back plate, swing the hopper's safety prop back into its stored travel position and reconnect the battery cables.

Replacing the Fan System Fan

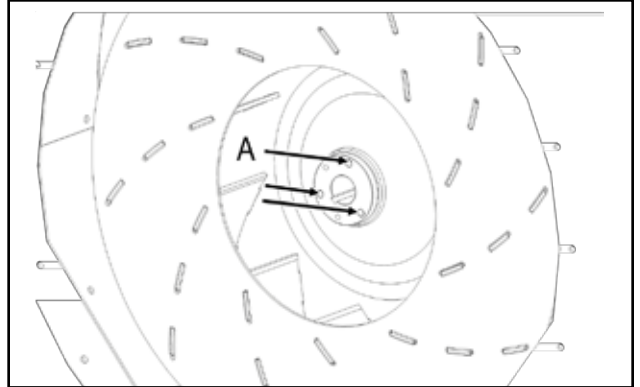

A Fan Bushing

If a worn fan is causing reduced sweeping efficiency, it should be replaced promptly. The fan shaft bearings have a life expectancy of roughly 2500 hours. When a fan replacement becomes necessary near the end of the bearing's life expectancy, the bearings should likewise be replaced.

Removal

- Raise the hopper and lower the safety prop into position.
- Remove the sweeper engine's keys and/or disconnect the battery cable to prevent the sweeper engine from being started accidentally.
- Remove the 3/8" bolts and washers from around the back cover plate and lift it off.
- Remove the 3/8" bolts and lock washers from the fan's bushing.

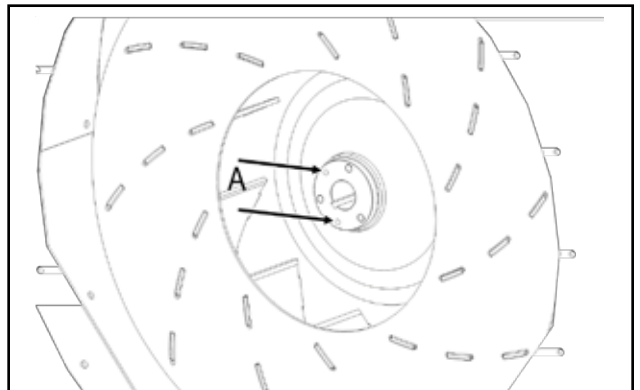

A Tapped Bushing Holes

5. Reinsert two 3/8" bolts into the tapped holes of the bushing. Tighten these bolts evenly. This will push the fan off the bushing.
6. Use a gear puller to remove the bushing from the fan shaft.
7. Remove the fan from the fan shaft and fan housing.

Replacement

8. Inspect the end of the fan shaft. Remove any burrs or rust from the shaft end with sandpaper.
9. Place the fan on the fan shaft and push it back into the fan housing.
10. Inspect the bushing. If the bushing is not cracked or otherwise damaged, the original bushing may be reused.
11. Apply an anti-seize agent to the tapered area of the bushing.
12. Slip the key into the bushing/fan shaft key-way.
13. Position the fan bushing onto the fan shaft while aligning it with the shaft key as well as the fan. Spread the bushing apart if necessary - remember, it will crack if it is overspread.
14. Drive the fan bushing onto the fan shaft until approximately 1/4" of the shaft extends from the face of the bushing. (Use a rubber hammer or a wooden block and metal hammer to drive the bushing on.)
15. Insert the three 3/8" bolts with lock washers through the untapped bushing holes and into the tapped holes of the fan. Finger tighten the bolts. Do not tighten the bolts so as to secure the fan to the fan shaft.
16. Apply strip caulk, or a similar sealing agent, to the face of the fan housing.
17. Install the back cover plate (it may be necessary to move the fan and its bushing further into the fan housing before the back cover plate can be mounted). Before tightening the bolts, pull the fan back until it contacts the back cover plate's inlet ring. Using the available slack, center the cover plate's inlet ring in the fan's orifice. Feel around the perimeter of the inlet ring to confirm an even gap or fit. Tighten the cover plate bolts.

18. Move the fan back onto the fan shaft. A gap distance will have to be determined (see illustration). The ideal gap distance is 1/4" from the cover plate orifice to the narrowest part of the fan's orifice
19. Position the fan on the fan shaft, taking into consideration that, as the fan is tightened onto its bushing, it will travel roughly 1/4" toward the cover plate's orifice.
20. While holding the fan in position on the fan shaft, tap the fan bushing along the fan shaft and into the fan's hub.
21. When the fan bushing is snug inside the fan's hub, insert the 3/8" bolts and tighten the fan onto the fan bushing. As the bolts are tightened and the fan is drawn onto the bushing, the fan should move 1/4" toward the cover plate.
22. Turn the fan to determine if the two orifices rub as the fan rotates. If the orifices touch, mark the bushing's present position on the fan shaft (so it may later be used as a reference point). Remove the fan from its bushing and follow steps 11-15 to remount the fan further into the fan house. If the orifices do not touch, proceed on to Step 16.
23. When the fan is properly mounted, swing the hopper safety prop into its stowed position and lower the hopper. Start the auxiliary engine and, again, listen for sounds of contact between the cover plate orifice and fan orifice. If none are audible, the unit is ready to sweep. If sounds are detected, the hopper should be raised and the fan readjusted.

Exceptions to fan/bearing replacement:

- If you sweep in extremely sandy conditions, or do not use the sweeper's water system, you may have to replace fans more often than bearings.
- If the proper bearing lubrication procedures aren't followed, you may have to replace bearings more often than fans.

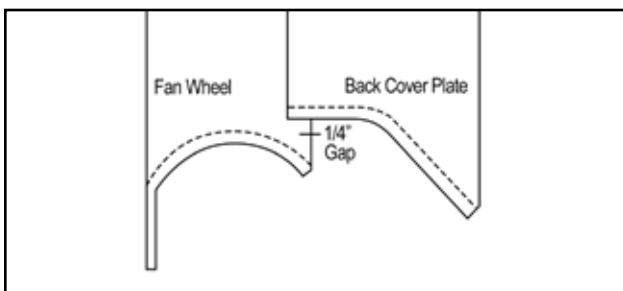

Replacing the Fan House Liner

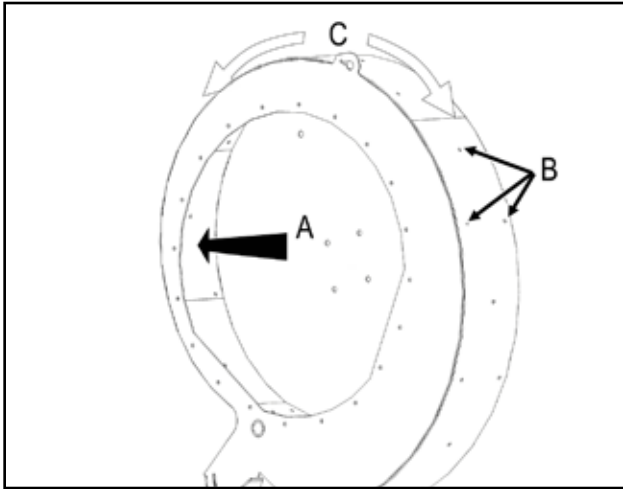

- A Fan Liner
- B Fan Liner Bolts
- C Install Out and Down

To prevent damage to the fan housing, a rubber liner is attached to the inside of the fan housing. Check the liner regularly for holes, tears or pitted areas. If the fan housing is exposed to direct wear because of a worn liner, the liner should be replaced.

1. Follow the procedures outlined in steps 1-7 in section 'Replacing the Fan System Fan' of this manual
2. Unscrew the 3/8" nuts from around the outside of the fan housing and remove the elevator bolts holding the rubber liner in place. Worn bolts should be discarded and replacements used upon re-installation.
3. Remove the worn liner.
4. Notice that the replacement liner hole pattern is different at each end. Be sure to position the liner so that the holes match the hole pattern of the fan housing.
5. Start by installing the elevator bolts that hold the rubber liner to the top of the fan housing, and then continue installing the remainder of the elevator bolts, working out and down from the top of the fan housing.

Replacing the Fan Shaft Bearing

Under normal operating conditions, the bearings should last approximately 2500 hours (check the auxiliary engine's hour meter). Bearing failure is accompanied by abnormal noise, vibration and/or the slinging of grease caused by ruptured bearing seals. Worn bearings should be replaced immediately to prevent damage to other sweeper components. Usually, accompanying drive belts, pulleys and bushings are also replaced. This ensures proper performance and eliminates repetitive maintenance and downtime.

Disassembly

1. Follow the procedures outlined in steps 1-7 in section 'Replacing the Fan System Fan' of this manual
2. Follow the procedures outlined in steps 1-4 in section 'Drive Belt Tension Adjustment' of this manual
3. Remove fan pulley off load adapter assembly shaft.
4. Remove the 8 bolts holding load adapter to fan housing support upright and remove load adapter.

NOTE The adapter is serviced as a complete unit.

5. Inspect the fan shaft drive pulley and drive belt. If either is damaged or too worn for reuse, discard and replace.

Replacement

1. Install the 8 bolts holding load adapter to fan housing support upright.
2. Replace fan pulley onto new load adapter shaft.
3. Check the alignment of the pulleys, using a string or straight edge, from the face of one pulley to the face of the other to determine whether the pulleys are in line with each other.
4. If the pulleys are misaligned, back the fan shaft drive pulley off its bushing, move both in the proper direction for alignment, then retighten the bushing/pulley bolts.
5. Inspect the drive belt for wear and replace it with a new one if needed.
6. Slide the drive belt onto the engine and fan shaft pulleys.
7. Adjust the drive belt tension.
8. Inspect the fan for wear and replace it with a new one if needed.
9. Follow the steps outlined under 'Replacement' in section, 'Fan Replacement' section of this manual.
10. Swing the hopper safety prop back into its travel position.
11. Reconnect the engine's battery cable, lower the hopper and check the operation of the sweeper.

Hydraulic System Service Schedule

We recommend the service listed in the following table.

Service	Frequency
Check hydraulic system pressure and adjust.	As Needed
Check Oil level.	Daily
Hydraulic Tank with internal filter.	
Change Oil	<ul style="list-style-type: none"> At 2,000 hours since last change or if the hydraulic fluid becomes cloudy, water has contaminated the system. It should be changed and flushed
Change Filter	 <ul style="list-style-type: none"> When "Change Filter" icon appears on console.
Hydraulic Tank with external filter.	
Change Oil & Filter	<ul style="list-style-type: none"> At new sweeper's first 500 hours of operation 2,000 hours since last change or if the hydraulic fluid becomes cloudy, water has contaminated the system. It should be changed and flushed

Hydraulic Tank

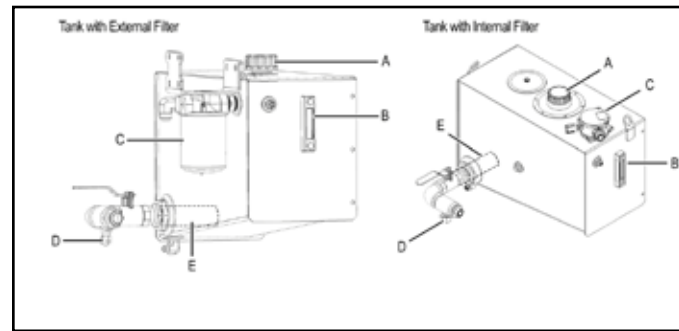

- A Fill Opening
- B Hydraulic Fluid Gauge
- C Hydraulic Return Filter
- D Hydraulic Tank Drain
- E Hydraulic Suction Filter/Strainer

The hydraulic tank is located on the left side of the sweeper between the power module uprights.

Filling The Tank

1. Examine the hydraulic fluid sight-level gauge located on the side of the tank (B). The fluid level should register at or about the high mark.
2. Locate the fill opening on top of the hydraulic tank. (A)
3. Remove the fill cap.
4. Use a funnel to fill the hydraulic reservoir to the desired level with one of the following:
 - Shell Tellus 68 hydraulic fluid
 - Citgo 68 hydraulic fluid
 - An equivalent 22-weight (SAE) fluid
 - 30-weight (SAE) fluid for systems operating with an ambient fluid temperature greater than 100°F.
5. Replace the cap

Draining The Tank

1. Locate the drain hose attached to the bottom of the hydraulic tank. (D) This drain hose exits the bottom of the tank, and is usually stored between the uprights and engine, or run down the back of the power module beside the fan house.
2. Place a 25 gallon capacity container on the ground, positioning it below the drain.
3. Remove the JIC plug from the end of the drain hose.
4. Allow all the fluid to drain.
5. Reattach the JIC plug to the end of the drain hose.

Replacing the Hydraulic Suction Filter/Strainer

1. Drain the hydraulic tank following the procedures outlined in Section, 'Draining the Tank'

2. Locate the suction filter protruding from the suction line's tank flange located near the bottom of the hydraulic tank. (E)
3. Remove the suction hose and its fittings from the center of the strainer.
4. Unscrew the strainer from the hydraulic tank.
5. Examine the suction strainer.
6. If the strainer is clogged, clean it with an approved cleaning solvent.
7. If the strainer is damaged, replace with an S-5 strainer.
8. Screw the cleaned or replacement strainer into the tank.
9. Re-attach the hose and its fittings to the center of the strainer.

Replacement the Hydraulic Return Filter

1. Locate the return filter. (C)
2. Unscrew the old canister from the filter head.
3. Fasten the replacement filter canister to the filter head

Adjusting the Hydraulic System Pressure

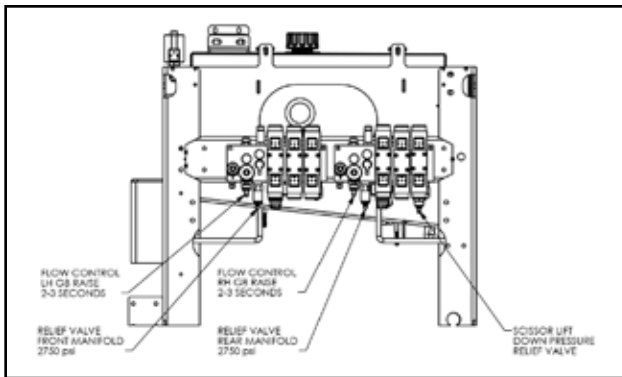

Only under maximum load, the hydraulic system runs at a relief hydraulic pressure of 2500 psi. Under normal operation, hydraulic pressure runs well below this.

Hydraulic Pump Pressure Check

Before adjusting:

- Check the electric and hydraulic systems for loose connections.
- Check the hydraulic fittings and hoses for leaks.
- Check the fluid for contamination and proper fill level.

Pressure Verification:

Use the 5000psi pressure gauge equipped with the Parker PD Series quick connect.

1. Connect the pressure gauge to manifold quick connect.
2. Start the auxiliary engine and throttle up to approximately 2000 rpms.
3. Have an assistant hold the side broom switch in the 'raise' position and continue to hold the switch in this position even after the side broom is fully raised.
4. Check the pressure gauge; it should read 2500 psi while the switch is being held. When the switch is released, the pressure gauge reading should change to about 800 psi.
5. If the pressure gauge reading is considerably different, you may need to adjust the manifold's pressure relief valve.

Pressure Relief Valve Adjustment

1. Locate the relief valve labeled 'RV', screwed into the bottom of the manifold block.
2. Turn the relief valve stem's jam nut 1/8 of a complete revolution at a time. Turn the relief valve stem clockwise to increase the fluid pressure, and counter-clockwise to decrease the pressure.

Checking the Directional Valve Override

In the hydraulic system, fluid flow direction is used to control the various hydraulic functions. The directional valve determines the flow direction. If the directional valve is faulty and unable to reverse the hydraulic fluid flow, the directional valve's hydraulic function will not operate properly.

Override Check

1. Locate the directional valve attached to the manifold block of the power module.
2. Locate the solenoid and two plugs that are attached with wires at either end of the directional valve. Each plug contains a small light that illuminates whenever that solenoid is electrically activated.
3. With the auxiliary engine running, toggle the in-cab console control panel switch that controls the hydraulic function for that particular directional valve.
4. One of the two lights should illuminate, indicating power is being supplied to that side of the directional valve. If neither light operates, the directional valve is not receiving power and the problem is electrical.
5. If the directional valve lights operate when the in-cab console control panel switch is toggled, the problem may be within the directional valve.

6. On either end of the directional valve is a small hole, about 1/8" in diameter. With the auxiliary engine running, insert a small nail or small Phillips screwdriver to insert into the holes (one at a time) at either end of the directional valve to manually override the directional valve. There is an initial easy push of the plunger, then a greater amount of pressure must be used to overcome the spring. If this procedure corrects the hydraulic function problem, then the directional valve is faulty and should be repaired or replaced.

6.6 Dust Suppression System

For dust suppression during sweeping operations, water flows from the water reservoirs and through the 'Y' strainer and the hydraulically-driven water pump. Then, it goes through the water manifold and hoses to the spray nozzles.

Water being drawn from the water reservoir to the water pump passes through the Y strainer screen, trapping and preventing debris from reaching the rest of the dust suppression system.

We recommend the maintenance listed in the following table:

Service	Frequency
Clean the 'Y' Strainer	Daily
Inspect and clean the nozzles	Daily
Winterize the system	When Needed

Refilling the Water Tank

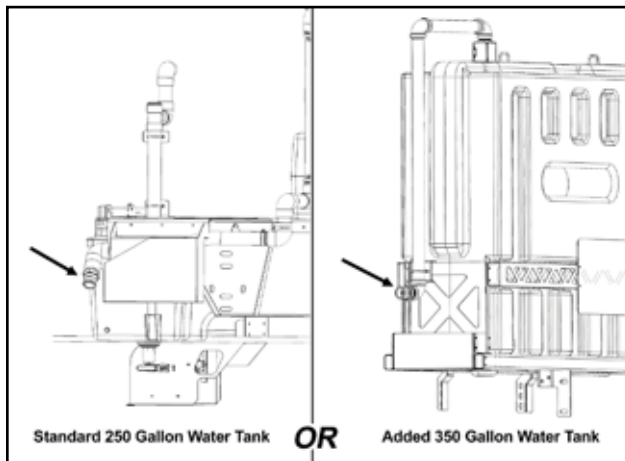

1. Turn on the hydrant and allow the water to run for a short period of time so any rust and/or sediment trapped in the water line can be cleared. An uncleaned water line can introduce debris to the sweeper's water system.

2. Remove the 2-1/2" hydrant hose from the storage rack and attach one end to the hydrant. Attach the other end to the pipe feeding the fill opening of the water tank.
3. Allow the reservoir to fill until water gushes from its overflow.

Cleaning the Water Manifold Solenoid

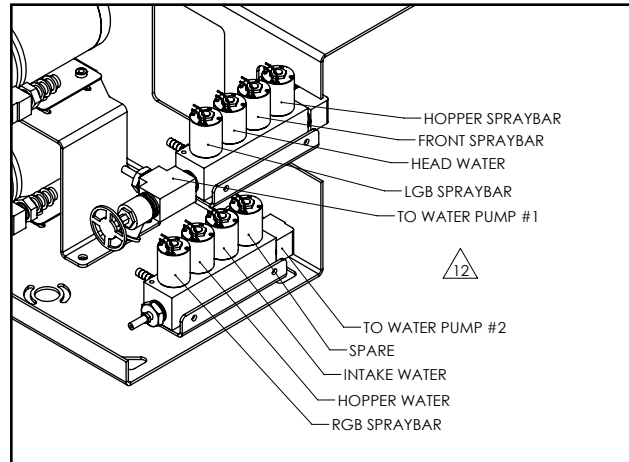

The water manifold solenoid should be cleaned when the nozzle has been cleaned or replaced and:

- Water leaks or sprays weakly from the nozzles.
- Little or no water flows from the nozzles.

IMPORTANT Never use ANY type of cleaning fluid to clean the solenoid valve plunger assembly or seals.

Cleaning

1. Shutoff all electrical current and pressure.

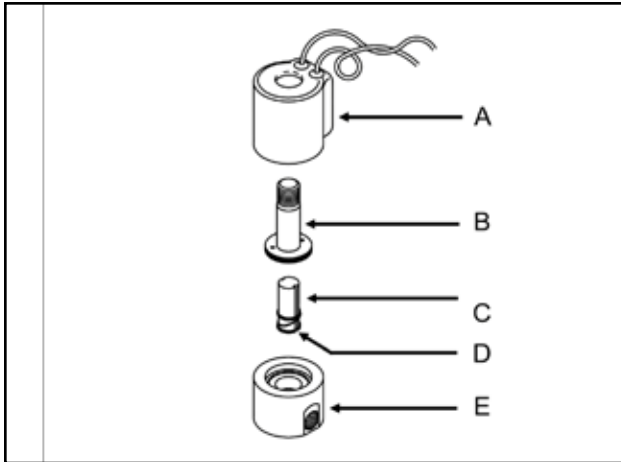

- A Solenoid Housing
- B Sleeve Assembly
- C Plunger
- D Soft Insert
- E Base

2. Remove the nut at the top of the solenoid valve.
3. Remove the name plate, coil and housing from the body.
4. If the valve does not leak from the seat and the plunger does not stick in the energized position, the problem is electrical and further cleaning is not required.
5. If the valve leaks from the seat or the plunger does stick in the energized position, proceed to the next step.
6. Use the supplied Peter Paul wrench to remove the sleeve assembly.
7. Examine the soft inserts in the plunger and carefully clean.
8. Examine the inside of the sleeve assembly and carefully clean.
9. If the inserts show excessive wear, replace the plunger.
10. If the valve emitted a loud buzzing noise during operation, examine both the inside of the sleeve and upper portion of the plunger and remove all foreign matter.
11. After cleaning or replacing parts, verify that both the flange seal and the return spring are in place.
12. Loosely screw the sleeve assembly into the body.
13. If the valve has a sleeve port, cap the port and apply pressure to the port leading to the body chamber.

14. If the media is air or gas, apply water to the joint and watch for air bubbles.
15. Reattach the name plate, coil, and housing to the body.
16. Carefully tighten the nut at the top of the solenoid valve. Excessive tightening of the nut can cause unnecessary strain on either the sleeve assembly or the coil under the housing.
17. Restart the electrical current and pressure.

Cleaning/Replacing the 'Y' Strainer

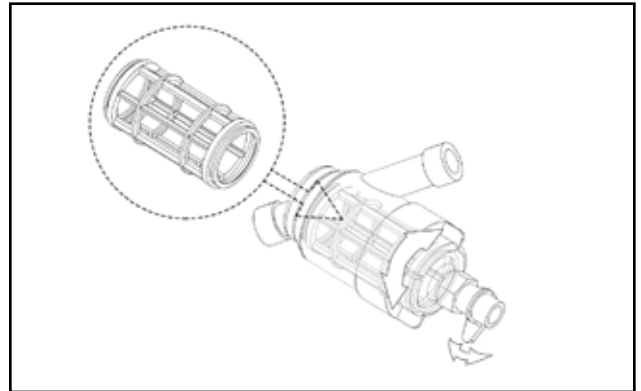

Cleaning/Replacement

Cleaning the 'Y' strainer requires opening the 'Y' strainer housing. This procedure should be done at the end of the work shift when the reservoir's water level will be at its lowest.

1. Turn off the ball valve.
2. Unscrew the bottom of the 'Y' strainer.
3. Remove the screen from inside the 'Y' strainer housing and examine.
4. Remove any debris inside the 'Y' strainer and rinse the cylindrical screen.
5. If the strainer is damaged, replace it.
6. Slip the screen back into position.
7. Reassemble the 'Y' strainer housing.

Water Pump Pressure Check

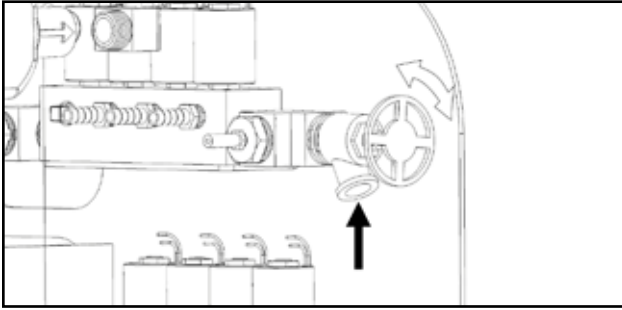

1. Turn off the auxiliary engine.
2. Use a gauge to check the pump's output pressure. Attach a pressure gauge (able to measure at least 500 psi) to the boiler drain on the front of the fill hose storage rack.
3. Open the boiler drain.
4. Turn on the water pump.
5. Be sure all the console control panel switches operating the sweeper's water functions are in the off position.
6. If the gauge reads roughly 50 psi, no adjustment is needed.
7. If the pressure gauge reading is considerably different from 50 psi, you may need to adjust the water pump's relief valve. Pressure that is jet too high can cause premature water pump failure.
8. Locate the relief valve in the group of fittings attached to the pressure port of the pump.
9. Screw the jam nut away from the relief valve's body.
10. Turn the hexed stem of the relief valve to adjust the water system pressure.
11. When the water pressure is roughly 50 psi, run the jam nut back against the body of the relief valve.

Water Nozzle Cleaning/Replacement

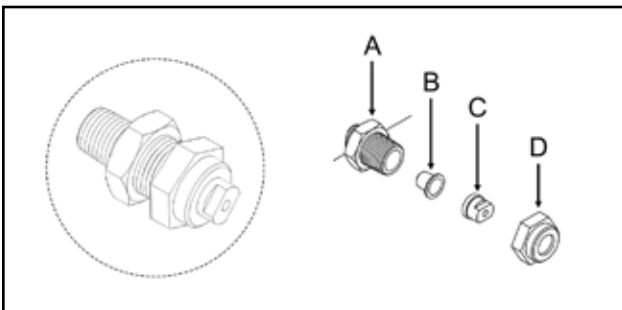

- A Spray Body
- B Water Filter Mesh
- C Spray Tip
- D Spray Tip Retainer Nut

Due to dusty conditions encountered during sweeping operations, dirt and debris particles entering the dust suppression system are sometimes small enough to pass through the 'Y' strainer. These particles can build up within a nozzle's openings, restricting water flow. When this occurs, the nozzle must be cleaned or replaced.

Cleaning/Replacement

1. Unscrew the nozzle retainer nut (D).
2. Remove the spray tip and strainer (B & C).
3. Wash the strainer and examine it.
4. If washing the strainer has removed all particles or debris, set aside the (now clean) strainer.
5. If the strainer can no longer be thoroughly cleaned, it needs to be replaced.
6. Wash the spray tip and examine it.
7. If the spray-tip opening is clogged, insert a small-gauge wire into the spray-tip opening to clear any debris lodged inside.
8. If the spray tip is damaged, it needs to be replaced.
9. Reassemble the nozzle, replacing any damaged parts as necessary.

Dust Suppression System Winterizing

Winterizing your sweeper will help keep it in top operating condition, extending its length of service.

If your sweeper's dust suppression system **will** be operated during freezing temperatures, follow the system winterization section.

If your sweeper's dust suppression system **will not** be operated when freezing temperatures are expected, drain the system.

System Winterization

1. Following the antifreeze manufacturer's instructions, add environmentally safe antifreeze to the water by pouring it through the air-gap opening in the top of the reservoir.
2. Start the auxiliary engine.
3. Turn on the water pump drive motor
4. Turn on all cab console control panel switches controlling water manifold solenoids.
5. Leave switches on until the antifreeze/water mixture flows from the spray nozzles.
6. Turn off all cab console control panel switches controlling water manifold solenoids.
7. Turn off the auxiliary engine.

System Draining

1. Unscrew the bottom of the 'Y' strainer housing to drain the water reservoir(s).
2. After the water flow stops, reassemble the 'Y' strainer housing.
3. Turn on all cab console control panel switches controlling water manifold solenoids.

Display Panel Descriptions

Operator's Screen

There are a number of dealer accessible settings and adjustments that may be accessed and selected. This appendix will go into details about these settings and adjustments.

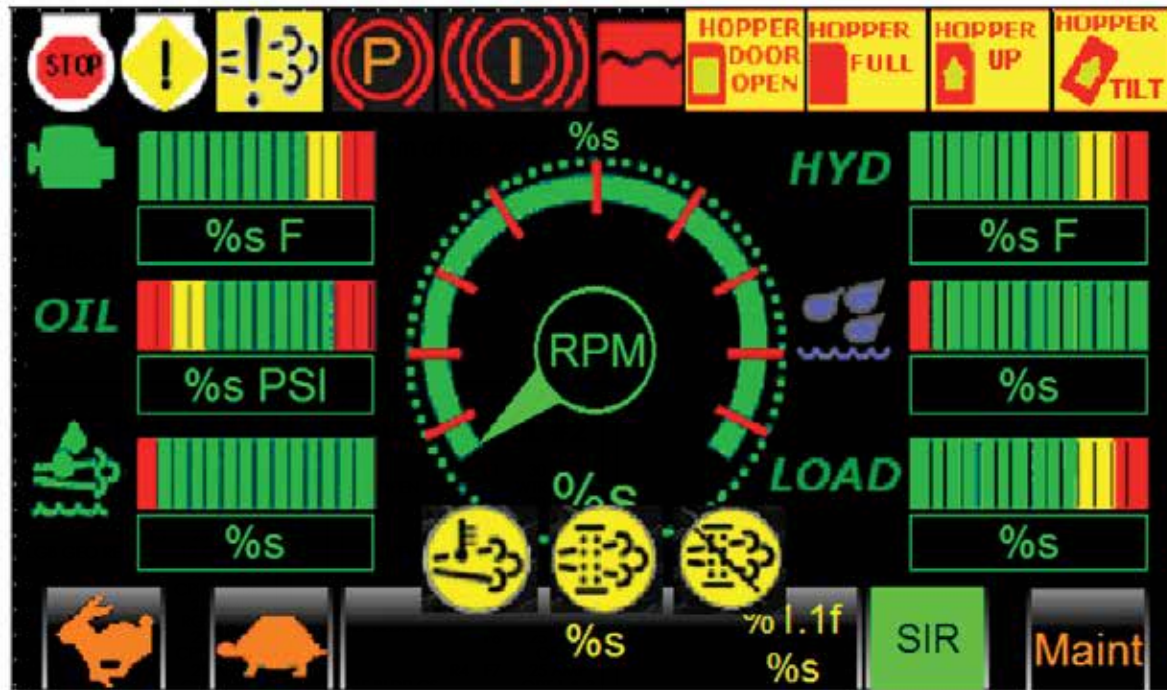

	F8	20 AMP
		CPU2 VBBS
OPEN	R5	F9
		30 AMP
		HOP SHKR
	F10	20 AMP
		CPU2 VBBS

	F8	10 AMP
		BEACON
OPEN	R5	F9
		25 AMP
		BOOM PWR
	F10	10 AMP
		SNSR PWR

Menu Controls

This manual will refer to the keys that have the names assigned below.

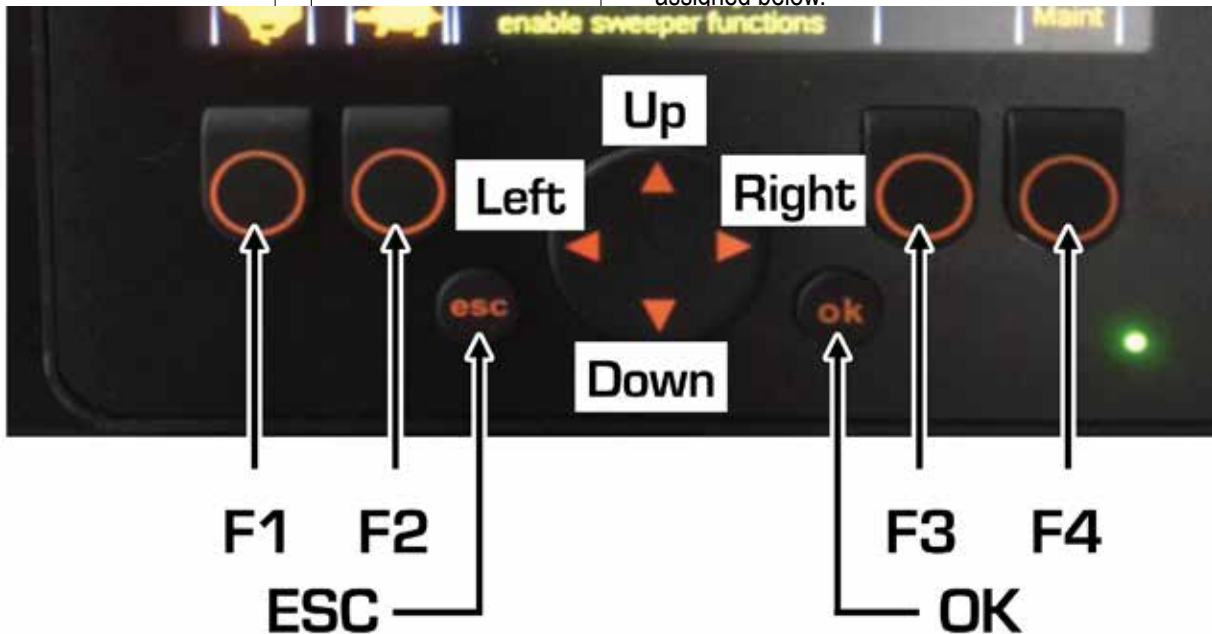

Emission Control Catalyst Cleaning (Regen) , Engine Fault Codes and Other Engine Data

The Schwarze A series utilizes very low emission Tier 4 off-highway engines featuring state of the art emission controls. These emission controls are controlled by the engine computer and need very little maintenance. If something does need attention, a series of notifications and warnings will appear on the main sweeper display screen. If actions are required, instructions are found on the “Engine Trouble Codes” screen as described in this section.

One action that is likely is the need to clean the catalyst. The Engine is equipped with a catalyst that may need to have some combustion by-products burned off. Normally the catalyst cleans itself. During the cleaning process the exhaust temperature lamp will appear and rpm will not drop below 1250 rpm. This cleaning process takes about 30 minutes. Always attempt to let this process complete itself by allowing the engine to continue running. Shutting off the engine will stop the process and it will need to start over when the engine is restarted. This condition is completely normal and sweeping may continue as normal.

Note: Unless in a emergency, the cycle should be inhibited, engine idled, high temp icon extinguished before shutting down the engine.

In some cases a more thorough cleaning may be needed. The instructions for a manually initiated thorough catalyst cleaning, also called “regen”, can also be found in this section.

The following engine codes can be visible on the operator’s screen:



CRITICAL FAULT - Engine has a critical fault. It needs the attention of a qualified engine service dealer. This could be a catalyst that was not cleaned and has exceeded the maximum cat soot level. The engine will be de-rated.



WARNING SYMBOL - Engine has sent a warning that a code has been sent. If this concerns emission controls, the catalyst may have reached its maximum cat soot level. A forced regen must be performed immediately.



EMISSION FAULT - The engine controller has sent a code that indicates an emission system fault. Contact a service dealer immediately.

The following catalyst cleaning (regen) codes can be visible on the operator’s screen:



Catalyst has reached maximum temperature, and cleaning is in process. Be sure no flammable materials are near the exhaust.



A forced cleaning is needed soon. Normal work can continue unless the warning symbol also appears. A forced clean must then be performed immediately.



Catalyst cleaning (regen) cycle has been inhibited by the operator from the “Engine Trouble Codes” screen. This prevents the catalyst cleaning cycle. This is only for temporarily delaying the cycle. Leaving this inhibited for long periods will damage the catalyst.

Cleaning the Catalyst

Performing a forced catalyst cleaning (regen) - The Catalyst lamp must be lit.

1. Move the sweeper to an area where no flammable materials will be near the exhaust.
2. Set the parking brake
3. Start the Aux engine and allow it to idle
4. Make sure all sweeper functions are turned off
5. Hold the F3 Key 3 seconds
6. The cleaning cycle can take up to 45 minutes. During this cycle the engine rpm will be set to 1800 rpm.

Note: If the cycle is interrupted before it is completed, it must be restarted from the beginning.

Maintenance and additional Screens

To select the maintenance key code screen. Press F4 "Maint" on the operator's screen.



1. BACK - Menu "Back" Button
 2. RST HRS - Hour Reset Button
 3. SKR JSX - Disables/Enables Auto Vibrator from dump joystick.
 4. BRM - Allows the brooms to spin freely (for changing broom segments). Hold for 2 seconds to toggle.
- Red marked areas are reserved for Schwarze factory and dealer personnel only.

Resetting Equipment Hour Meters

Use the menu navigation pad to highlight the desired hour meter. Press the “OK” button to select the hour meter and press the “Rst Hrs” button to reset the meter.

NOTE Engine hours (Eng Hrs) can not be reset.

The Engine Trouble Codes screen

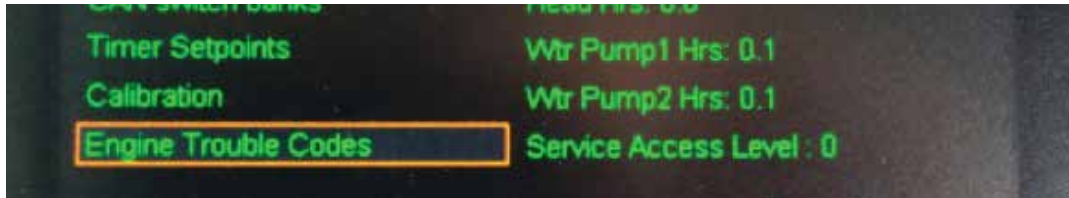

Use UP/DOWN arrows to highlight “Engine Trouble Codes” and press the “OK” button.

The following screen will appear.

Catalyst Conditions

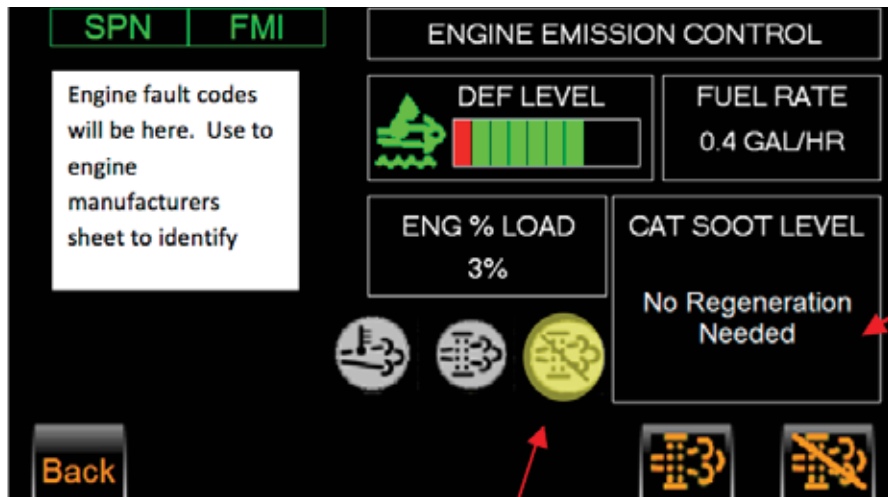

There are 6 levels of Catalyst condition. Level zero shown here.



Note: The Catalyst cleaning function should remain enabled (non –inhibited) unless otherwise instructed by your dealer.

Symbol will be yellow if active

Force Catalyst	Catalyst cleaning inhibit
Clean cycle	On/off

Catalyst Condition / Soot Levels

CAT SOOT LEVEL LOW Auto Regen If INHIBIT Allows	CAT SOOT LEVEL MODERATE Auto Regen If INHIBIT Allows	CAT SOOT LEVEL HIGH Auto Regen If INHIBIT Allows Manual Stationary Regen Available	CAT SOOT LEVEL VERY HIGH Perform Manual Stationary Regen Or Engine Will Be De-rated 50%	CAT SOOT LEVEL SERVICE ONLY Service Tool Regen Must Be Performed!!!
--	---	---	--	---

Diesel Particulate Filter State (SPN 3701)	0	1	2	3	4	5
Soot Load Level	Not Needed	Low	Moderate	High	Very High	Service Only
State Description	No regeneration needed. Natural cleaning can occur.	Automatic cleaning will occur if inhibit switch allows.	Automatic cleaning will occur if inhibit switch allows.	Automatic cleaning will occur if inhibit switch allows. Manual cleaning can be requested.	Manual cleaning must be initiated to reduce soot level. 50% de-rate is typical.	Service cleaning must be initiated with service tools to reduce soot level. Low idle, no-load de-rate.
Symbols Displayed	None	None	None	 (Solid)	 (Flashing) (Solid)	 (Flashing) (Solid)

Bortek®

WE KNOW CLEAN®

Bortek Industries, Inc. - Authorized Dealer
4713 Gettysburg Road, Mechanicsburg, PA
800.626.7835
www.sweeperland.com



Schwarze is different. Our machines are designed, built and supported in a different way. That difference comes from an engineering heritage. A heritage of thinking first about the people who actually use the machines. About how to help them be safer, more comfortable, more productive. About the environment we all share. The result of that thinking is a growing range of machines and a global support network dedicated to helping you do more. People around the world are proud to use Schwarze.

The People You Know. The Products You Trust.

Under our policy of continuous improvement, we reserve the right to change specifications and design without prior notice. Illustrations do not necessarily show the standard version of the machine.

Schwarze Industries, Inc.
1055 Jordan Road, Huntsville, AL 35811
800.879.7933 - www.schwarze.com