



 EQUIPMENT

 PARTS

 RENTALS

 SERVICE

 SUPPLIES

SERVICE MANUAL

CONTACT US

 800.6.Bortek

 717.737.7591

 Orders@BortekIndustries.com

 BortekIndustries.com 



HAMMERHEAD[®]

950MS

EXPLODED VIEW OF MACHINE

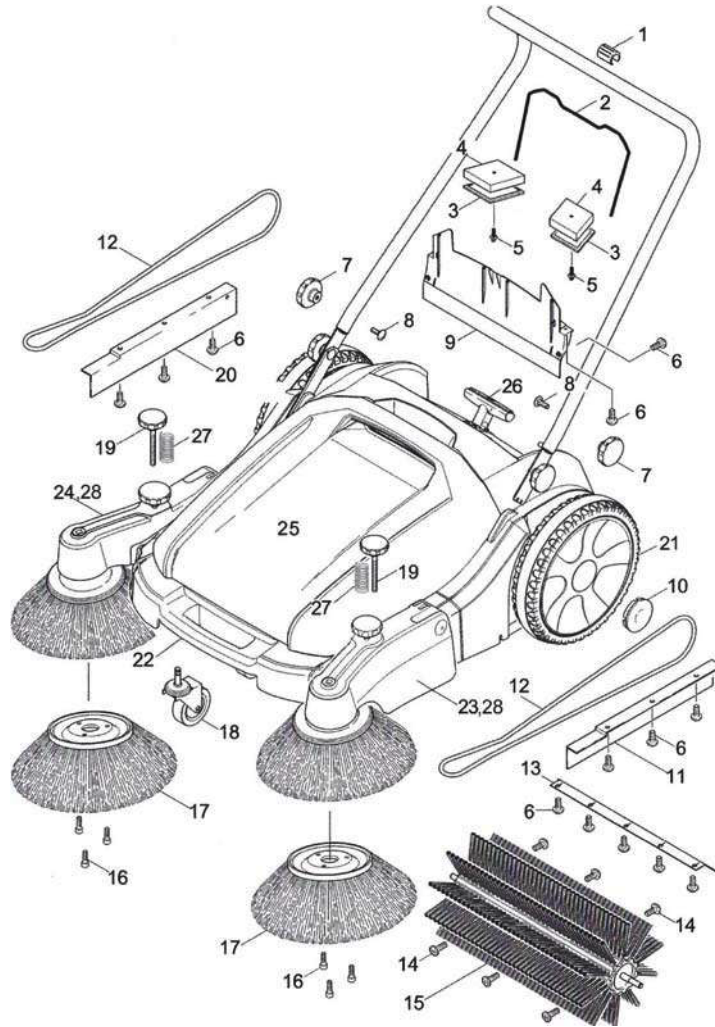

- | | |
|-----------------------------------------------------------------------------------------------------------------------------------------------------------------------------------------------------------------------------------------------------------------------------------------------------------------------------------------------------------------------------|----------------------------------------------------------------------------------------------------------------------------------------------------------------------------------------------------------------------------------------------------------------------------------------------------------------------------------------------------------------------------------------------------------|
| <ul style="list-style-type: none"> 1. Clamp 2. Seal rubber 3. Filter covering cap 4. Filter 5. Plug 6. Screw 7. Turning knob 8. Saucer-head screw 9. Rear Skirting 10. Wheel cap 11. Skirting 1 12. Round belt 13. Ground lip 14. Screw | <ul style="list-style-type: none"> 15. Rolling brush complete 16. Screw 17. Side brush 18. Castor 19. Turning knob 20. Skirting 2 21. Wheel 22. Frame 23. Arm right 24. Arm left 25. Debris container 26. Adjusting lever 27. Spring for side brush 28. Pulley block |
|-----------------------------------------------------------------------------------------------------------------------------------------------------------------------------------------------------------------------------------------------------------------------------------------------------------------------------------------------------------------------------|----------------------------------------------------------------------------------------------------------------------------------------------------------------------------------------------------------------------------------------------------------------------------------------------------------------------------------------------------------------------------------------------------------|

TECHNICAL DESCRIPTION	U/M	950MS
Working width with two side brushes	in	36
Container Capacity	gal	10.5
Maximum Theoretical Area Performance	ft ² /hr	39,611
Net weight	lbs	52.5
Dimension	in	51x31x41
Dimension (folded)	in	35x31x15

PACKAGE CONTENTS



Sweeper body

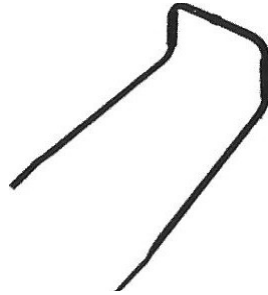

Handle- 1 Pc

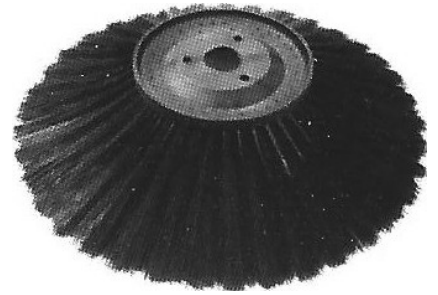

Front brush- 2 Pcs



Turning knob - 2 Set



Bolt- 2 Set



Screw- 6 Set



Wrench

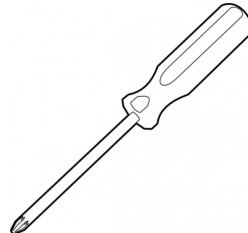

Phillips Screwdriver

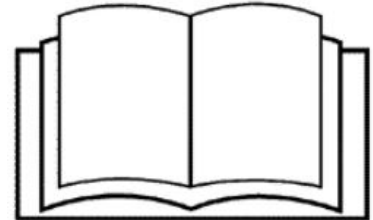

Instruction manual

NOTE

1. This Unit is designed for outdoor and hard flooring. Home carpet may not be suitable for use with this machine.
2. Before use, make sure the unit is in good and safe working condition.
3. The sweeper is not suitable for sweeping up liquids. Do not sweep up burning or glowing objects, e.g. cigarettes, matches or similar.
4. Heavy stones and large size debris may be unable to be collected.
5. Please lift the two side brushes when cleaning the large dust condition.
6. Please avoid sweeping long rope or yarn like material to avoid brushes tangling and being damaged; if this happens, remove by reversing the roller brush.

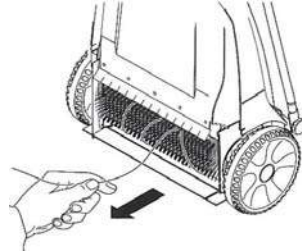

SAFETY WARNING!

1. When sweeping and operating the machine in front of children, please be extremely careful and remain aware of your surroundings.
2. Please do not use the unit as a toy for children.
3. Please do not let your hair, feet, fingers, clothes etc. of your body get caught in the garbage collecting mouth of the unit.
4. Please do not operate the sweeper barefoot or wearing footwear that exposes your feet.
5. Please do not sweep hot, burning, or smoking debris in order to avoid any fire hazard or personal injury.
6. Please do not collect flammable and explosive and stuff and poisonous material!
7. When collecting any shards of glass or other sharp and potentially hazardous materials, please wear safety gloves.
8. Please do not operate and store the unit close to heating source.
9. Please store the unit in a safe place to avoid any unintentional damage.
10. Please use sturdy gloves when removing glass, metal or other materials from the dirt container.

HOW TO USE

1. Take out the brushes from the debris container and screw in the brushes.

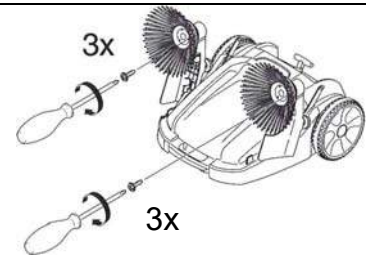

2. Retaining screws are used with the knobs to adjust the handle.

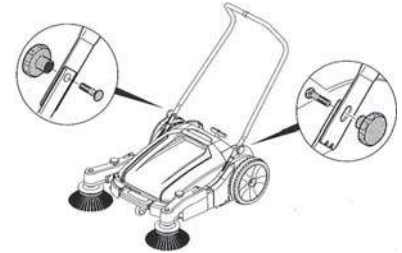

3. Three-position adjustable handle is in place for maximum operator comfort and convenience.

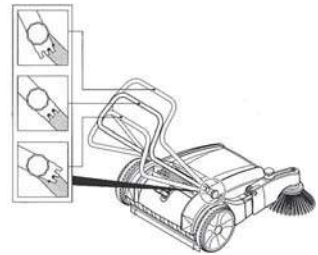

4. Adjustable roller broom height with 6 different positions.

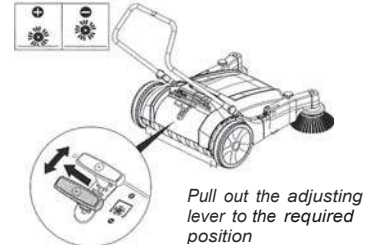

5. Easy-to-adjust front brush pressure for outstanding sweeping performance.

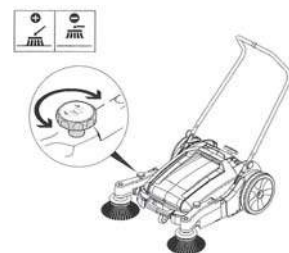

6. Adjustable side broom swings out of the way when use is not required.

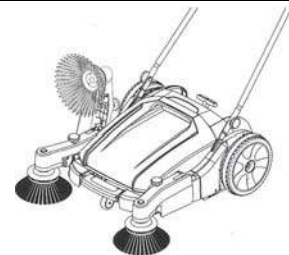

EMPTY THE HOPPER AND HOW TO REMOVE COMPONENTS

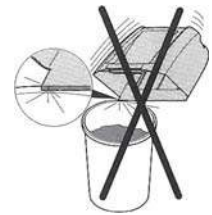
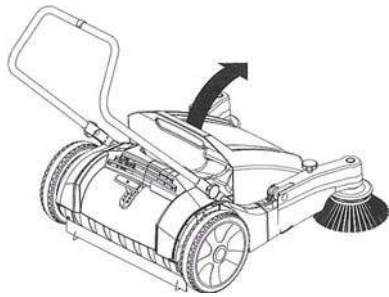

1. Lift the debris container handle and detach the hopper.
2. Collect the hopper and empty in the appropriate waste container.*

*NOTE: DO NOT POUND HOPPER AGAINST WASTE RECEPTACLE. Doing so may result in damage to the hopper or the receptacle.

GROUND LIP

Unscrew all retaining screws.
The ground lip can then be taken out

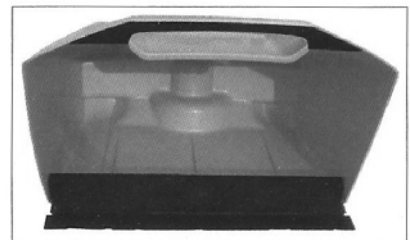

REAR SKIRTING

Unscrew all retaining screws.
The rear skirting can then be taken out.



SKIRTING

Unscrew all retaining screws.
The rear can then be taken out.

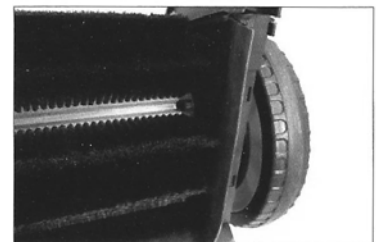

MAINTENANCE

The broom can be cleaned with water. Avoid using hot water or heat air blowing.

Sweeper body can be cleaned with water. Avoid have it in direct sunlight for long periods of time

Spool cords and threads must removed for best result.

As this machine is used regularly, ensure you tighten, every now and then, the front castor with our specially-made wrench to avoid having any looseness in the wheel or worse, have it fall of while in operation.



WHEEL

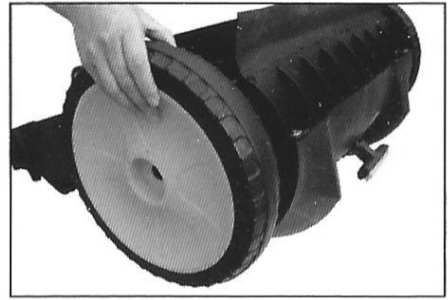
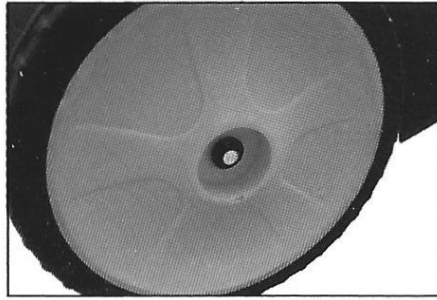
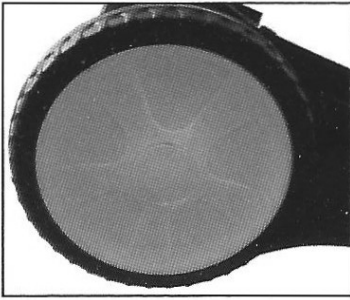

1. Use a screwdriver to unclip the cap cover in the middle of the wheel
2. Use wire cutting pliers to disconnect and remove the lock washer

The lock washer is broken when removed. A new lock washer must be used to reinstall the wheel.

3. The wheel can be pulled off the axle

ROUND BELT

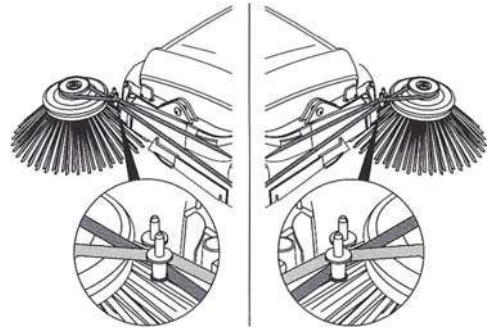

When installing the drive belt, pay attention to the rotational direction of the side brush. When moving forward, the side brush must rotate towards the inside.

OPERATION

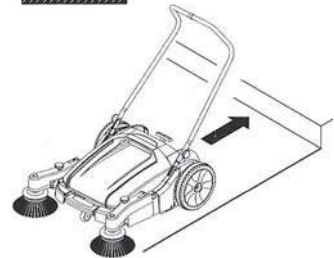
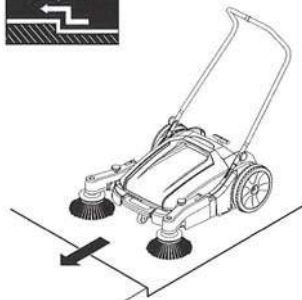

1. Hand push action. Extremely easy to use. Normal walking speed recommended.
2. Ideal for cleaning paths, halls, sidewalks and warehouses quickly and conveniently.
3. Suitable for fine dust and small pieces, like sand, grain, nails and bolts, iron filings, sawdust, papers.
4. The cleaning surface should be completely flat or a height difference of ≤ 2.5 cm. Walking the step in the opposite direction ≤ 19 cm.

STORAGE

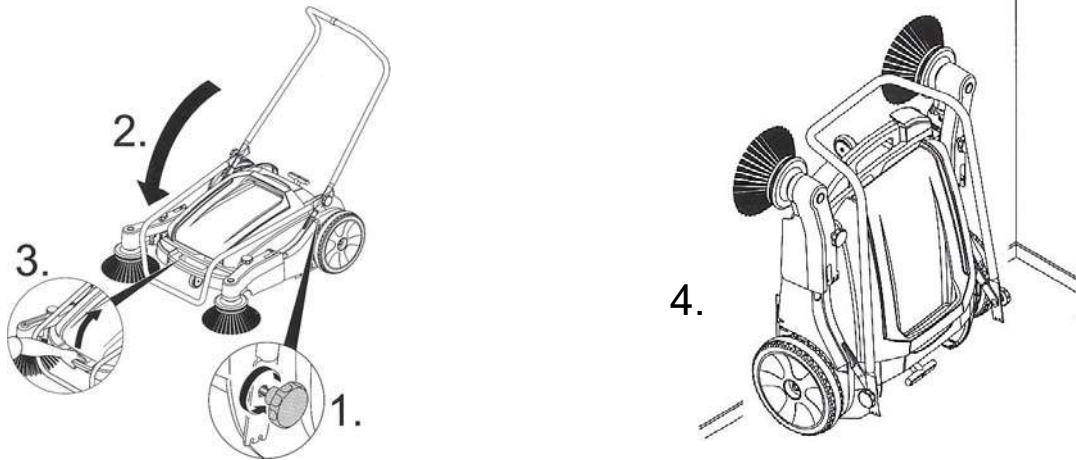

Space Saving Storage.
Folds completely flat for convenient storage.

PROBLEM TREATMENT

Fault	Solution
Unsatisfactory sweeping result	Empty debris container Adjust height of main brush/clean/replace Adjust height of side brush and clean/replace Check/replace the drive belt for side brush

PARTS REPLACEMENT

MAINBRUSH

To dismantle the main brush, unscrew all 6 retaining screws. The two main brush half-shells can then be taken out.

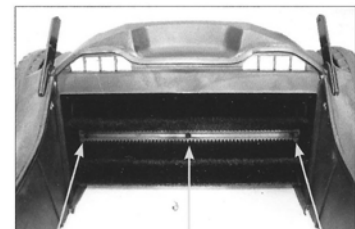

FINE FILTER CLEAN AND REPLACEMENT

Pull out the retaining pin and remove the fine filter for cleaning or replacement.

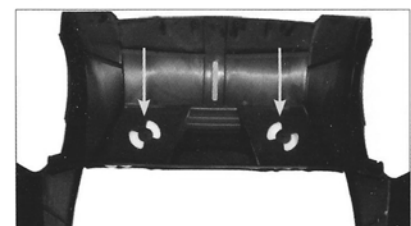
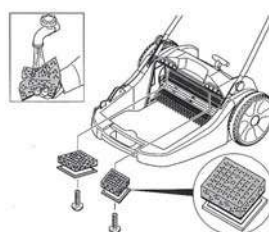
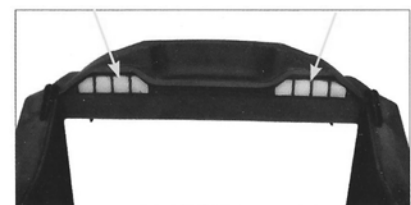



950MS Specs and NOTES

MODEL 950MS
WEIGHT 23.8kg
BATTERIES None
DRIVE Manual forward and reverse belt drive system
WORK RATING 3,680 square meters per hour
MAINBROOM PATH 920mm
MAX. GRADIENT N/A
SPEED Manual
CAPACITY 40L
SWEEPING SYSTEM Double round brush, and one roller brush
DIMENSIONS 1300X790X1035mm
SAVE ROOM Can be folded
PACKAGE CARTON
PACKAGE DIMENSIONS 890X810X400mm
APPLICATION Indoor, Outdoor



NOTES



HAMMERHEAD®



950 MS



750 RS



450 RS



550 RDX



500 RS



650 RDX



500 SS



700 RSX



600 SS



750 RDX



650 RS



870 SR

HEADQUARTERS

4713 Gettysburg Road
Mechanicsburg, PA 17055 USA

CONTACT US

800.6.Bortek

717.737.7591

Orders@BortekIndustries.com

BortekIndustries.com/**CUSTOMERLINK**

SWEEPERLAND.COM

The complete family of
power cleaning machines.