

***Minuteman***<sup>®</sup>  
Excellence Meets Clean

MRS  
Mercury Recovery Systems



## Key Features

- Extremely portable, highly maneuverable
- U.L.P.A. filters are 99.999% effective at 0.12 microns
- Each model contains a large capacity activated carbon filter
- Unique modular 4-element system that allows user-tailoring to fit almost any need
- Tool kit, which will handle most clean-up jobs, is included

## Markets/ Applications

- Technical laboratories
- Medical and dental labs
- Control rooms
- Dental offices
- Research laboratories
- Shipboard applications
- Instrument manufacturing facilities
- Mining

## Accessories/Options

- Wide range of tools and attachments in a variety of sizes
- Dry only units can be adapted for wet pickup with the addition of a water shut-off module
- Complete line of filters and collection bags available

## General Overview

- Allows for safe, affordable clean-up of liquid mercury and mercury contaminated soil and air
- Mercury Recovery Vacuum System can be tailored to fit almost any particular need
- MRS1,2,3 and 4 are designed with high-quality stainless steel 15 gallon tanks
- MRS6 Maxi-Guard II is a small, portable 6 gallon vacuum
- All units feature a 115v or 220v AC/DC air-cooled motor
- U.L.P.A. filtration meets or exceeds the IEST-RP-CC0007 specifications



MRS 1 - for liquid mercury recovery (Includes Separator)



MRS 2 - for recovery of mercury contaminated dust (with U.L.P.A.)



MRS6 (Maxi-Guard II) a small, lightweight unit for emergency mercury cleanup (dry only)



MRS 4 - for recovery of mercury contaminated liquids (Wet Only)



MRS 3 - for pickup of liquid mercury and mercury contaminated particulate matter (Includes U.L.P.A. and Separator Jar)

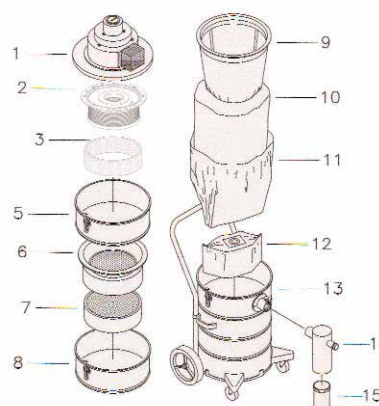

## Filter System - MRS 3

1. Lid Assembly
2. U.L.P.A. Filter Module
3. Pre Filter
5. Adapter
6. Filter Holder
7. Mercury Vapor Canister
8. Adapter
9. Cloth Bag Assembly
10. Dacron Filter
11. Filter Protector
12. Disposable Paper Bag
13. Tank 15 Gallon
14. Separator
15. Separator Jar

## Specifications

Model Number	MRS1	MRS2	MRS3	MRS4	MRS6
Static Lift	110"(2,794mm)	110"(2,794mm)	110"(2,794mm)	110"(2,794mm)	88"(2,159mm)
Airflow	115CFM(3.25m <sup>3</sup> /min)	115CFM(3.25m <sup>3</sup> /min)	115CFM(3.25m <sup>3</sup> /min)	115CFM(3.25m <sup>3</sup> /min)	95CFM(2.7m <sup>3</sup> /min)
Power (watts)	1480	1480	1480	1480	1480
Cord	16-3/50'(15m)	16-3/50'(15m)	16-3/50'(15m)	16-3/50'(15m)	16-3/50'(15m)
Wet Capacity	N/A	N/A	N/A	10gal(38ltr)	N/A
Dry Capacity	.82 cu ft(.02m <sup>3</sup> /min)	.82 cu ft(.02m <sup>3</sup> /min)	.82 cu ft(.02m <sup>3</sup> /min)	2.1 cu ft(.05m <sup>3</sup> /min)	.62 cu ft(.02m <sup>3</sup> /min)
Filter Area	3,234sq in(20,864cm <sup>2</sup> )	3,234sq in(20,864cm <sup>2</sup> )	4,400sq in(28,387cm <sup>2</sup> )	N/A	552sq in(3,561cm <sup>2</sup> )
Height	41"(104cm)	46"(116cm)	46"(116cm)	46"(116cm)	25"(63cm)
Width	21"(53cm)	21"(53cm)	21"(53cm)	21"(53cm)	21"(53cm)
Voltage	115 (220)	115 (220)	115 (220)	115 (220)	115 (220)
Wheel Size -Front	3" (8cm)	3" (8cm)	3" (8cm)	3" (8cm)	Optional
Wheel Size - Rear	8" (20cm)	8" (20cm)	8" (20cm)	8" (20cm)	Optional
Wet/Dry	N/A	N/A	N/A	N/A	N/A
Weight	62lbs(28kg)	73lbs(33kg)	78lbs(35.5kg)	70lbs(31.5kg)	24.5lbs(11kg)

Specifications subject to change without notice.

Minuteman is a full line manufacturer of sweepers and scrubbers; as well as critical filter vacuums, industrial and commercial vacuums, floor and carpet machines, and litter vacuums for commercial and institutional facilities, whereas PowerBoss is a full line manufacturer of sweepers and scrubbers for industrial facilities.

Bortek Industries Inc  
4713 Gettysburg Rd.  
Mechanicsburg, PA 17055  
Phone: (717) 737-7162  
Fax: (717) 731-8230



Come Visit our Website at  
[www.sweeperland.com](http://www.sweeperland.com)