

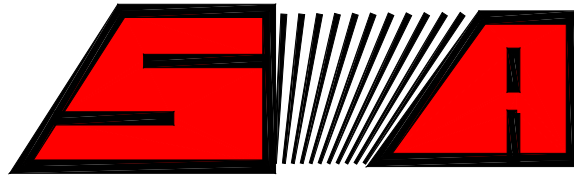

# Starfire S-4 Sweeper Body Safety, Operations and Maintenance Manual



# **STEWART-AMOS**

**Sweeper Co.**

**SN 4016 & UP**





## Table of Contents

<b>Safety</b>	<b>14</b>
Safety Is A Shared Responsibility	15
Recognize Safety Information	15
Equipment Lockout	16
Hopper Port Restrictors	16
General Safety Precautions	17
Before Operating Machine	17
When Operation Machine	17
When Servicing Machine	17
Safety Features	18
Follow Safety Instructions	19
Prevent Bypass Starting	19
Handle Fuel Safely-Avoid Fires	19
Prepare For Emergencies	20
Never Use Starting Fluid	20
Wear Protective Clothing	20
Protect Against Noise	20
Handle Chemical Products Safely	20
Dispose Of Waste Properly	21
Practice Safe Maintenance	21
Work In Ventilated Area	22
Avoid High-Pressure Fluids	22
Avoid Heating Near Pressurized Fluid Lines	23
Remove Paint Before Welding Or Heating	23
Service Cooling System Safely	23
Avoid Harmful Asbestos Dust	24
Stay Clear Of Rotating Equipment	24
Diesel Fuel Storage	25
Filling Fuel Tank	25
<b>Warranty</b>	<b>26</b>
Warranty Certificate	27
General Conditions	27
Items Not Covered By Warranty	28
Items Covered By Separate Warranty	28

<b>General Specifications</b>	<b>30</b>
Serial Number Location	31
<i>Figure 1: Serial Number Plate</i>	
<b>Chassis</b>	<b>32</b>
International Truck Specifications	32
GMC Truck Specifications	32
Chassis Instrumentation	33
Mounted Specifications	33
Auxiliary Engine/Sweeper Instrumentation	33
Engine (Auxiliary)	34
Dirt Hopper	34
Elevator	34
Main Broom	34
Gutter Broom	34
Lighting System	35
Hydraulic System	35
Water System	35
<b>Controls</b>	<b>36</b>
Engine Controls	37
<i>Figure 2: Engine Control Box</i>	38
Sweeper Control	39
Sweeper Controls	39
LH Gutter Broom tilt Up/Down	39
Beacon Lights On	39
RH Gutter Broom Tilt Up/Down	39
Brooms Up/Down	39
GB Lights On/GB/MB Lights On	39
Sweep Forward/Sweep Reverse	39
Hopper Up/Down	40
Water	40
Hopper Dump/Retract	40
LH Gutter Broom Up/Down	40
RH Gutter Broom Up/Down	40
<i>Figure 3: Sweeper Control Box</i>	41

<b>Operation</b>	44
Auxiliary Engine	45
Water Fill Up	46
<i>Figure 4: Water Tank</i>	46
Sweeping	47
Dumping	48
Break-In Period	50
Engine Break-In	50
Sweeper Break-In	50
Winterizing Your S-4	51
<b>Service</b>	52
Fuel, Lubricants, and Coolants	52
Diesel Fuel	52
Diesel Engine Oil	52
Coolant	52
Hydraulic Oil	52
Grease	53
Lubrication and Maintenance	53
Daily	53
<i>Figure 5: Service Locations On Auxiliary Engine</i>	54
Every 50 Hours	54
Every 250 Hours	54
Every 500 Hours	55
Every 1000 Hours	55
<b>Adjustments</b>	<b>56</b>
Gutter Broom Angle Adjustment	56
Correct Gutter Broom Angle	56
Adjust Tilt Angle	56
Adjust Front to Back Angle	56
Gutter Broom Pressure	57
Correct Gutter Broom Pressure	57
Adjusting Gutter Broom Pressure	57
Sweeping Width	57
Gutter Broom Impact Protection Spring	58
<i>Figure 6: Gutter Broom Assembly</i>	59
<i>Figure 7: Correct Broom Pattern</i>	60
Main Broom Pressure	61
<i>Figure 8: Main Broom Assembly</i>	61
Elevator Chain Adjustment	62
Upper Drive Shaft Adjustment	62
Center Idler Shaft Adjustment	62
<i>Figure 9: Elevator Chain Adjustment</i>	63

<b>Repair and Maintenance</b>	<b>65</b>
Gutter Broom Segment Replacement	66
Main Broom Strip Replacement	66
<i>Figure 10: Main Broom Assembly</i>	67
<i>Figure 11: Main Broom Arm Assembly</i>	67
Main Broom Bearing Replacement	68
Carbide Drag Shoe Replacement	68
<i>Figure 12: Carbide Drag Shoe</i>	69
Elevator Chain Replacement	69
<i>Figure 13: Elevator</i>	71
Bottom Liner Replacement	72
Top Liner Replacement	72
Main Broom Hydraulic Motor Replacement	72
Gutter Broom Hydraulic Motor Replacement	73
Elevator Hydraulic Motor Replacement	73
Hydraulic Pressure Adjustment	74
<i>Figure 14: Hydraulic Valves</i>	74
Stall Switch Adjustment	75
<b>Lubrication and Maintenance Check List</b>	<b>77</b>



# DEALER FORMS

The following forms must be completed and signed by the DEALERS REPRESENTATIVE.  
Then remove from manual and returned to the following address:



**2700 Paxton St.  
P.O. Box 2043  
Harrisburg, PA 17105**

Failure to return the completed and signed **Pre Delivery Inspection** and **In Service Date Registration** forms to the above address may void all warranties.







## Pre Delivery Inspection Checklist

To be filled out by the dealer prior to delivery to the end user.

Return this document to Stewart-Amos Sweeper Co. within 30 days of delivery to end user.

Dealer: \_\_\_\_\_ End User: \_\_\_\_\_

Date: \_\_\_\_\_ Serial #: \_\_\_\_\_

VIN: \_\_\_\_\_ Mileage: \_\_\_\_\_ Hours: \_\_\_\_\_

### Bolts and Nuts

#### Hopper Safety Supports \_\_\_\_\_

#### Hopper Safety Bolts \_\_\_\_\_

Chassis Suspension	_____	Sweeper Mounting	_____
Drag Shoe Mounts	_____	Drag Shoe Link Pins	_____
Drag Shoe Chains	_____	Main Broom Rock Shaft	_____
Main Broom Suspension Shaft	_____	Main Broom Skirt	_____
Main Broom Coupler	_____	Main Broom Shafts	_____
Main Broom End Plates	_____	Main Broom Bearing	_____
Main Broom Bearing Set Screws	_____	Main Broom Chains	_____
Main Broom Suspension Turnbuckle	_____	Elevator Mounts	_____
Elevator Bearings	_____	Elevator Canopy	_____
Elevator Extension Canopy	_____	Hopper Door Cylinders	_____
Water Tank Straps	_____	Gutter Broom Mounts	_____
Gutter Broom Pins	_____	Gutter Broom Plates	_____
Gutter Broom Linkage	_____	Gutter Broom Segments	_____
Engine Skid Mounting	_____	Engine Mounts	_____
Hydraulic Pump Mount	_____	Bell Housing Mount Plate	_____
Hydraulic Tank Mount	_____	Hydraulic Valve Mounts	_____
Battery Box Mount	_____	Aux. Engine Control Box	_____
Aux. Engine Exhaust Pipe	_____	Aux. Engine Intake Rain Cap	_____
Front Canopy Mount	_____	Rear Canopy Mount	_____
Canopy Door Hinges	_____	Lights	_____
Control Box Mounting	_____	Fuel Tank Mounting	_____

### Cotter Pins and Snap Rings

Scissor Snap Rings	_____	Hopper Door Cyl.	_____
Hopper Door Pin	_____	Main Broom Cyl.	_____
Hopper Tilt Cyl. Pins	_____	Main Broom Linkage	_____
Hopper Lift Cyl. Pins	_____	Elevator Linkage	_____



Sweeper Co.

**Hoses and Fittings**

Tank to Pump (Suction)	_____	Pump to RH Stack Valve	_____
RH Stack Valve	_____	RH Float Valve	_____
Pump to LH Stack Valve	_____	LH Stack Valve	_____
LH Float Valve	_____	Hopper Lift Cyl.	_____
RH Gutter Broom Lift Cyl.	_____	RH Gutter Broom Motor	_____
RH Retract Cyl.	_____	LH Gutter Broom Lift Cyl.	_____
LH Gutter Broom Motor	_____	LH Gutter Broom Retract Cyl.	_____
MB/ELEV Lift Cyl.	_____	Main Broom Motor	_____
Elevator Motor	_____	Hopper Dump Cyl.	_____
Hopper Door Cyl.	_____	Hydraulic Tank Site Gauge	_____
Magnetic Drain Plugs	_____	Case Drain Lines	_____
Hydraulic Filter	_____	Hydraulic Filter Manifold	_____
Valve Stack Return Lines	_____	Hydraulic Cooler to Manifold	_____

**Fluid Levels**

**Chassis**

Engine	_____
Transmission	_____
Differential	_____
Brake Fluid	_____
Power Steering	_____
Engine Air Filter	_____
Radiator	_____
Tire Pressures	
Rear (psi)	_____
	_____
	_____
Front (psi)	_____
	_____

**Sweeper**

Engine Oil	_____
Hydraulic Oil	_____
Engine Air Filter	_____
Radiator	
Level	_____
Strength (-35 <sup>0</sup> )	_____



**Adjustments**

RH Stack Valve Hydraulic Pressure (passengers side)	2850 psi @ 2000 rpm	_____
LH Stack Valve Hydraulic Pressure (drivers side)	2350 psi @ 2000 rpm	_____
LH Stack Valve Stall Switch	2300 psi @ 2000 rpm	_____
Aux. Engine High Ideal (2850)	_____	Aux. Engine Low Ideal (850) _____
Hopper Proximity Switch	_____	Elevator Proximity Switch _____
Drag Shoes in Up Position (4")	_____	Main Broom Pattern _____
MB Suspension	_____	MB Centering _____
Elevator Down Position	_____	GB Front to Back Angle _____
GB Side To Side Angle	_____	GB Suspension _____
GB Sweeping Path	_____	Rear Camera Adjustment _____
GB Camera Adjustment	_____	Monitor Adjustment _____
Work Light Adjustment	_____	Chassis Mirrors _____

**Operations**

**Lights**

Brakes	_____	LH Turn Signal _____
RH Turn Signal	_____	Tail Lights _____
ID Bar	_____	LH Rear Door Marker _____
LH Upper Rear Corner Marker	_____	RH Rear Door Marker _____
RH Upper Rear Corner Marker	_____	License Plate _____
Backup Light	_____	Back Work Light _____
LH GB Work Light	_____	RH GB Work Light _____
Rear Strobe	_____	Front Strobe _____
High Beams	_____	Low Beams _____
Backup Alarm	_____	

**Aux. Engine**

Glow Plugs	_____	Starting _____
Tachometer/Hour Meter	_____	Oil Pres. & Set Point _____
Temperature & Set Point	_____	
Murphy Shut Down Set Points	_____	Throttle Cable/Actuator _____



Sweeper Co.

**Sweeper Controls**

Hopper Up/Down	_____	Dump/Ret.	_____
MB/ELEV Up/Down	_____	MB/ELEV Sweep For/Rev	_____
RH GB Tilt In/Out	_____	RH GB Independent Up	_____
LH GB Tilt In/Out	_____	LH GB Independent Up	_____
Water Sweeping Only	_____	Water Continuous	_____
Camera Curb Side	_____	Camera Rear	_____
Camera Reverse	_____	Monitor	_____
Brooms Pickup In Reverse	_____	Elevator Stall Switch	_____

**Dust Suppression**

Water Tank	_____	Bottom Fitting	_____
Fill Valve	_____	Fill Valve Linkage	_____
Water Pump	_____	Pump Off When Brooms Up	_____
Filter Housing	_____	Filter Screen	_____
Shutoff Valve	_____	Front Spray Bar	_____
Front Bar Shutoff Valve	_____	Rear Spray Bar	_____
Rear Bar Shutoff Valve	_____	LH GB Spray Bar	_____
LH GB Shutoff Valve	_____	RH GB Spray Bar	_____
RH GB Shutoff Valve	_____		

**Test all sweeping functions at operating rpm (2400) and temperature.**

MB Pattern	_____	LH GB Pattern	_____
RH GB Pattern	_____	GB to MB Overlap	_____
LH GB Retract	_____	RH GB Retract	_____
Hopper Dump/Retract	_____	Hopper Lift/Lower	_____
Brooms Sweep For/Rev.	_____	LH GB Independent Up	_____
RH GB Independent Up	_____	Brooms Up In Reverse	_____
Rear Camera In Reverse	_____	All Lights	_____

**Miscellaneous Items**

Weather Stripping Bottom of Lift Frames	_____
Weather Stripping On Hopper Door	_____
Manuals In Cab	_____
Engine	_____
Chassis	_____
Parts Manual	_____
Incomplete Vehicle Stickers	_____
All Body Decals and Safety Warnings	_____

Signature: \_\_\_\_\_ Date: \_\_\_\_\_



Sweeper Co.

**IN SERVICE DATE REGISTRATION FORM**

**To be filled out by the dealer prior to delivery to the end user.**

**Return this document to Stewart-Amos Sweeper Co. within 30 days of delivery to end user.**

Sweeper Body Serial Number: \_\_\_\_\_  
(found next to chassis VIN plate)

Customer Name: \_\_\_\_\_

Address: \_\_\_\_\_  
\_\_\_\_\_  
\_\_\_\_\_

Phone # (include area code): \_\_\_\_\_

Date Unit Delivered: \_\_\_\_\_

In Service Date: \_\_\_\_\_

Contact Name: \_\_\_\_\_

Signature: \_\_\_\_\_

This form MUST be completed and returned to Stewart-Amos Sweeper Co. for warranty purposes.

**FAILURE TO COMPLETE AND RETURN THIS FORM MAY RESULT IN DENIAL OF WARRANTY CLAIMS.**

**Stewart-Amos Sweeper Co.  
2700 Paxton Street  
P.O. Box 2043  
Harrisburg, PA 17105**





# Safety

Safety is always of prime importance when operating any type of machine or vehicle in the vicinity of people. **All persons working with this unit are to be knowledgeable of the safety practices and features detailed in this section.**

### **Safety Is A Shared Responsibility**

Safety is everyone's responsibility. Working together with Safety as the prime objective will insure a safe work environment and reduce injuries.

The operator must become familiar with safe operating procedures and use the equipment in the fashion that it was intended. Routine inspections and maintenance will prevent premature wear, expensive downtime and ensure that the equipment functions as it is intended.

### **Recognize Safety Information**

This is the safety alert symbol. When you see this symbol in the manual or on your machine, be alert to the potential for personal injury.



**DANGER: Identifies the most serious hazard**

**WARNING: Identifies a potential hazard if safety precautions are not taken**

**CAUTION: Identifies a general safety precaution**



## Equipment Lockout

It is strongly recommended that a commonly known Equipment Lockout procedure be enforced at your work environment. This is a series of precautions designed to protect any personnel that is inspecting, cleaning, or repairing the equipment. The Lockout Procedure should include the following.

1. Apply Parking Brake.
2. Place hopper, hopper door in secure positions so that they can not accidentally fall. If required, install additional blocking devices such as hopper safety pins.
3. Turn off Auxiliary Engine.
4. With auxiliary engine off, turn key to run position and work hydraulic functions to relieve any residual pressure in the hydraulic system.
5. Remove keys from ignition.
6. Store keys in pocket or in a safe controlled area.
7. Place an "OUT OF SERVICE" sign on the steering wheel using a non-reusable fastener.
8. Place an "OUT OF SERVICE" sign on the front window.
9. Disconnect negative terminal from battery.

## Hopper Port Restrictors

To control the decent of the hopper under all conditions port restrictors are used in the hopper lift cylinders. These port restrictors are sized to give a controlled decent of the hopper even if a hydraulic hose would rupture with a full hopper at the top of its travel. The hopper would come back to the at rest position with minimal damage to the equipment.



**DANGER: Do not remove or modify any port restrictors**



## **General Safety Precautions**

### **Before Operating Machine**

1. Read the operators manual and the engine manual to familiarize yourself with safe operating practices before operating the machine.
2. Read the chassis operator's manual thoroughly to familiarize yourself with safe operating practices before operating machine.
3. Be sure all observers are clear of the machine and at a safe distance.
4. Ensure mirrors, windows, lights, and monitor equipment (if equipped), are clean and adjusted properly at all times.
5. Do not enter hopper unless engine is shut off, key is removed and there is a note posted indicating not to start the engine. (See Equipment Lockout).

### **When Operating Machine**

1. Operate controls from the operator's station only.
2. Keep all riders off the machine.
3. Keep all safety shields in place.
4. Ensure the area is clear of any persons or possible obstructions.
5. Do not wear loose clothing or jewelry.
6. Do not leave the vehicle before it is brought to a complete stop and the parking brake is applied.
7. Be cautious while driving with an unevenly distributed load.
8. Inspect for overhead hazards (e.g. power lines) before raising the hopper.
9. Raise the hopper only on level ground.
10. Ensure the hopper has completely lowered and the hopper door is closed before moving the vehicle. Do not move vehicle with hopper up.
11. Do not stand under the hopper when it is in the dump position.

### **When Servicing Machine**

1. Follow the Equipment Lockout procedure described above.
2. Install safety pins into holes in slide frame to prevent scissor frame from moving when servicing under the hopper. (See Safety Features).
3. Never work under a loaded hopper even with safety pins installed.



## Safety Features

This machine is equipped with many safety features. To operate this equipment safely, it is imperative to be aware of these functions. Please read all of the features listed, as the order they are presented does not reflect the degree of importance. Some safety features listed are options and MAY or MAY NOT be on your unit.

If there are concerns, report to your supervisor or maintenance department.

1. Decals - These must be clean and visible at all times.
2. Mirrors - A variety of mirrors, including large convex ones, are to help ensure adequate rear vision. These must be properly adjusted, clean and visible at all times!
3. Cameras – All machines are equipped with side and rear cameras, if so equipped, they must be in proper working order at all times. The rear camera option is also wired to the chassis transmission, when the chassis is shifted into reverse the rear camera will automatically activate and will go off automatically when chassis is shifted out of reverse.
4. Marker Lights - There is 1 marker lamp on each side of the sweeper and an ID bar at the back on the elevator cover. Marker lights are wired direct to chassis lights and come on with chassis lights.
5. Beacon and/or Strobe Lights - The switch is installed in the sweeper control box inside the cab. The lights are mounted on the front canopy of sweeper.
6. Gutter Broom Lights - These lights are used for work lights and are mounted at both gutter brooms. The switch is found on the control box in the cab.
7. Main Broom Light - This light is used for a work light and is mounted on the drivers side at the back above the main broom. The switch for this work light is combined with the gutter broom light switch in the 3rd position.
8. Backup Alarm - When the truck is put into reverse this alarm sounds. The alarm is mounted to the rear canopy frame.
9. Hopper Safety Prop - If any work is to be done under a lifted hopper, insert props into the main frame roller rails. This will restrict any movement of the scissors frame sliders, thus keeping the hopper stable. NEVER use the safety pins to hold a LOADED HOPPER!
10. Arrow Board (option) - A separate control box mounted in the cab controls the arrow board mounted on the rear of the sweeper. A switch and pattern selector with indicator lights controls the order the light pattern.
11. Fire Extinguisher (option) - This is located in the cab behind the driver's seat.
12. First Aid Kit (option) - This is located inside the cab behind the driver's seat.

## FOLLOW SAFETY INSTRUCTIONS

Carefully read all safety messages in this manual and on your machine safety signs.

Keep safety signs in good condition. Replace missing or damaged safety signs. Be sure new equipment components and repair parts include the current safety signs. Replacement safety signs are available from your dealer.



Learn how to operate the machine and how to use controls properly. Do not let anyone operate without instruction.

Keep your machine in proper working condition. Unauthorized modifications to the machine may impair the function and/or safety and affect machine life.



If you do not understand any part of this manual and need assistance, contact your dealer.

## PREVENT BYPASS STARTING

Do not start engine by shorting across starter terminal.

Start engines only from operator's station with transmission in park.



## HANDLE FUEL SAFELY-AVOID FIRES

Handle fuel with care: It is highly flammable. Do not refuel the machine while smoking or when near open flame or sparks.

Always stop engine before refueling machine. Fill fuel tank outdoors.

Prevent fires by keeping machine clean of accumulated trash, grease, and debris. Always clean up spilled fuel.

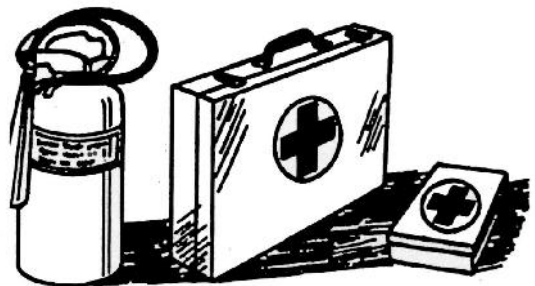

## PREPARE FOR EMERGENCIES

Be prepared if a fire starts.

Keep a first aid kit and fire extinguisher handy.

Keep emergency numbers for doctors, ambulance service, hospital, and fire department near your telephone.



## NEVER USE STARTING FLUID

Starting fluid is highly flammable and can cause serious damage to engines.

## WEAR PROTECTIVE CLOTHING

Wear close fitting clothing and safety equipment appropriate to the job.

Operating equipment safely requires the full attention of the operator. Do not wear radio or music headphones while operating machine.



## PROTECT AGAINST NOISE

Prolonged exposure to loud noise can cause impairment or loss of hearing.

Wear a suitable hearing protective device such as earmuffs or earplugs to protect against objectionable or uncomfortable loud noises.

## HANDLE CHEMICAL PRODUCTS SAFELY

Direct exposure to hazardous chemicals can cause serious injury. Potentially hazardous chemicals used with this equipment include such items as lubricants, coolants, paints, and adhesives.

A Material Safety Data Sheet (MSDS) provides specific details on chemical products: physical and health hazards, safety procedures, and emergency response techniques.



Check the MSDS before you start any job using a hazardous chemical. That way you will know exactly what the risks are and how to do the job safely. Then follow procedures and recommended equipment. (See your dealer for MSDS on chemical products used with this equipment.)

### **DISPOSE OF WASTE PROPERLY**

Improperly disposing of waste can threaten the environment and ecology. Potentially harmful waste used with this equipment include such items as oil, fuel, coolant, brake fluid, filters, and batteries.

Use leak proof containers when draining fluids. Do not use food or beverage containers that may mislead someone into drinking from them. Do not pour waste onto the ground, down a drain, or into any water source.

Air conditioning refrigerants escaping into the air can damage the Earth's atmosphere. Government regulations may require a certified air conditioning service center to recover and recycle used air conditioning refrigerants.

Inquire on the proper way to recycle or dispose of Waste from your local environmental or recycling center, or from your dealer.

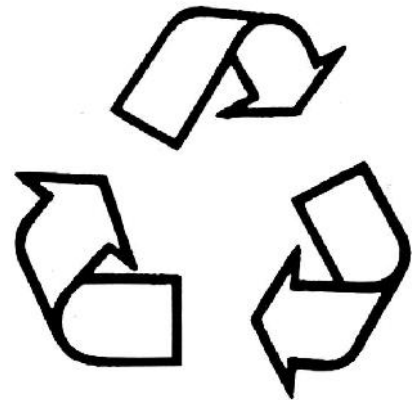

### **PRACTICE SAFE MAINTENANCE**

Understand service procedure before doing work. Keep area clean and dry.

Never lubricate, service, or adjust machine while it is moving. Keep hands, feet, and clothing from power-driven parts. Disengage all power and operate controls to relieve pressure. Lower equipment to the ground. Stop the engine. Remove the key. Allow machine to cool.



Securely support any machine elements that must be raised for service work.

Keep all pats in good condition and properly installed.

Fix damage immediately. Replace worn or broken parts. Remove any buildup of grease, oil, or debris.

Disconnect battery ground cable (-) before making adjustments on electrical systems or welding on machine.

### **WORK IN VENTILATED AREA**

Engine exhaust fumes can cause sickness or death. If it is necessary to run an engine in an enclosed area, remove the exhaust fumes from the area with an exhaust pipe extension.

If you do not have an exhaust pipe extension, open the doors and get outside air into the area.



### **AVOID HIGH-PRESSURE FLUIDS**

Escaping fluid under pressure can penetrate the skin causing serious injury.

Avoid the hazard by relieving pressure before disconnecting hydraulic or other lines. Tighten all connections before applying pressure.

Search for leaks with a piece of cardboard. Protect hands and body from high pressure fluids.

If an accident occurs, see a doctor immediately. Any fluid injected into the skin must be surgically removed within a few hours or gangrene may result. Doctors unfamiliar with this type of injury should reference a knowledgeable medical source.

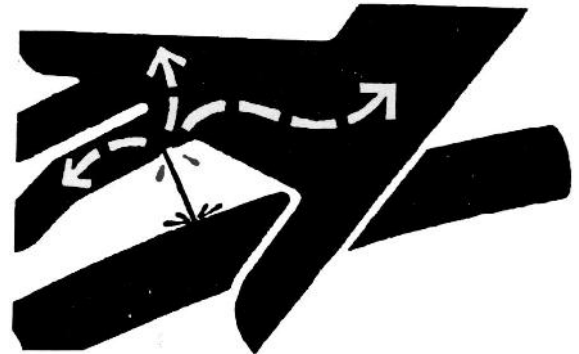

## **AVOID HEATING NEAR PRESSURIZED FLUID LINES**

Flammable spray can be generated by heating near pressurized fluid lines, resulting in severe burns to yourself and bystanders. Do not heat by welding, soldering, or using a torch near pressurized fluid lines or other flammable materials. Pressurized lines can be accidentally cut when heat goes beyond the immediate flame area.



## **REMOVE PAINT BEFORE WELDING OR HEATING**

Avoid potentially toxic fumes and dust.

Hazardous fumes can be generated when paint is heated by welding, soldering, or using a torch.

Do all work outside or in a well ventilated area.  
Dispose of paint and solvent properly.

Remove paint before welding or heating:

If you sand or grind paint, avoid breathing the dust.  
Wear an approved respirator.

If you use solvent or paint stripper, remove stripper with soap and water before welding. Remove solvent or paint stripper containers and other flammable material from area. Allow fumes to disperse at least 15 minutes before welding or heating.

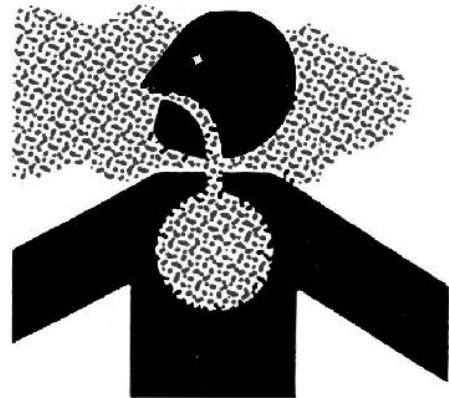

## **SERVICE COOLING SYSTEM SAFELY**

Explosive release of fluids from pressurized cooling system can cause serious burns.

Shut off engine. Only remove filler cap when cool enough to touch with bare hands. Slowly loosen cap to first stop to relieve pressure before removing completely.





## **AVOID HARMFUL ASBESTOS DUST**

Avoid breathing dust that may be generated when handling components containing asbestos fibers. Inhaled asbestos fibers may cause cancer.

Components in products that may contain asbestos fibers are brake pads, brake band and lining assemblies, clutch plates, and some gaskets. The asbestos used in these components is usually found in a resin or sealed in some way. Normal handling is not hazardous as long as airborne dust containing asbestos is not generated.

Avoid creating dust. Never use compressed air for cleaning. Avoid brushing or grinding materials containing asbestos. When servicing, wear an approved respirator. A special vacuum cleaner is recommended to clean asbestos. If not available, apply a mist of oil or water on the material containing asbestos. Keep bystanders away from the area.

## **STAY CLEAR OF ROTATING EQUIPMENT**

Entanglement in rotating equipment can cause serious injury or death. Keep shields in place at all times.

Wear close fitting clothing. Stop the engine before making adjustments or performing any type service on the equipment.



## DIESEL FUEL STORAGE

Proper fuel storage is critically important. Use clean storage and transfer tanks. Periodically drain water and sediment from bottom of tank. Store fuel in a convenient place away from buildings.

**IMPORTANT: DO NOT** store diesel fuel in galvanized containers. Diesel fuel stored in galvanized containers reacts with zinc coating on container to form zinc flakes. If fuel contains water, a zinc gel will also form. The gel and flakes will quickly plug fuel filters, damage injection nozzles and injection pump.

**DO NOT** use brass-coated containers for fuel storage. Brass is an alloy of copper and zinc.

## FILLING FUEL TANK



**CAUTION: Handle fuel carefully. Do not fill the fuel tank when engine is running. DO NOT smoke while filling fuel tank or servicing fuel system.**

**IMPORTANT:** The fuel tank is vented through the filler cap. If a new filler cap is required, always replace it with an original vented cap.

Fill fuel tank at the end of each day's operation to prevent condensation in tank as moist air cools and freezes during cold weather.

Store diesel fuel in plastic, aluminum, or steel containers specifically coated for diesel fuel storage.

Avoid storing fuel over long periods of time. If fuel is stored for more than a month prior to use, or there is a slow turnover in fuel tank or supply tank, add a fuel conditioner to stabilize the fuel and prevent water condensation. Fuel conditioner also reduces fuel gelling and controls wax separation during cold weather.

Consult your engine distributor or servicing dealer for recommendations and local availability. Always follow manufacturer's directions on label.





# WARRANTY



## WARRANTY CERTIFICATE

Stewart-Amos Sweeper Co. warrants each new machine manufactured to be free from defects in material and workmanship under normal use and service. The obligation under this warranty is limited to replacing F.O.B. its factory, Harrisburg, PA:

Any PART and labor within **ONE YEAR** (twelve months) or **ONE THOUSAND** (1000) **HOURS**, whichever occurs first, after making delivery of such machine to the original purchaser. This warranty is expressly in lieu of all other warranties expressed or implied and of all other obligations or liabilities on its part, and it neither assumes nor authorized any other person to assume for it any liability in connection with the sale, servicing or repair of any machine manufactured by it.

Stewart-Amos Sweeper Co. reserves the right to have any part being claimed for warranty returned, at customer expense, for inspection and determination that the part was factory defective.

Stewart-Amos Sweeper Co. reserves the right to make changes in design or to make additions to or improvements on its products previously manufactured.

### **Stewart-Amos Sweeper Co. – WARRANTY POLICY**

Stewart-Amos Sweeper Co. provides warranty to the original purchaser of a new product, that the same is free from defects in materials and workmanship that may cause performance failures, subject to the conditions stated herein.

The warranty is limited to a period of one (1) year from the date of the original purchase or 1000 hours, whichever occurs first, included are parts and labor costs associated with the warranty.

### **GENERAL CONDITIONS**

Stewart-Amos Sweeper Co. will honor warranty claims provided:

1. The unit is properly registered. Registration form is located at the front of the operator's manual. Registration form must be received by Stewart-Amos Sweeper Co. within 45 days of the sale. Failure to receive said warranty registration form within the prescribed time will cancel warranty coverage for the product.
2. The failure occurs within the warranty period and is covered under the terms of our written warranty.
3. The repairs are made and an authorized Stewart-Amos Sweeper Co. dealer has submitted a warranty claim within 30 days of completion of repair.
4. The unit has not been altered in any way without prior written approval by Stewart-Amos Sweeper Co.



Sweeper Co.

5. All warranty repairs reimbursable must be performed by an authorized dealer using Stewart-Amos Sweeper Co. approved replacement parts. Failure to repair properly voids future warranty.



## **ITEMS NOT COVERED BY WARRANTY**

1. Set-up and pre-delivery services, service calls, diagnostics, or after sales adjustments due to normal operations, including travel time/mileage.
2. Sweepers sold for use outside of North America.
3. Repairs, modifications or alterations to the machine without the express written consent of Stewart-Amos Sweeper Co.
4. Including but not limited to normal wear parts such as brooms, drag shoes, rubber deflectors, filters, oil, fuel, chains, belts, brakes or other wear parts.
5. Items that, in the opinion of Stewart-Amos Sweeper Co. have been subject to misuse, abuse, negligence, accident or improper maintenance.
6. Failures resulting from the machine being operated in a manner or for a purpose not recommended by Stewart-Amos Sweeper Co.
7. Rentals, consequential or collateral damage, down time costs, or lost revenue incurred due to a failure during the warranty period.
8. Consumables or shop supply materials such as paint, anti-freeze, oil, fuel, bolts.

## **ITEMS COVERED BY SEPARATE WARRANTIES**

1. Parts and components such as the chassis, auxiliary engine, pump, motors, and other similar major components which are under separate warranties from their respective manufacturers. Service for these components can be obtained from their service facilities in the United States. In some circumstances, extended warranties are available at an extra cost. Please contact your Stewart-Amos Sweeper Co. dealer for information on these extended warranties.

## **GENERAL INFORMATION AND PROCEDURES**

2. Ensure the **IN SERVICE DATE** form has been sent in.
3. Keep all replaced parts for 180 days after mailing of claim. Stewart-Amos Sweeper Co. retains the right to request that you return failed parts for quality analysis. When returning parts for warranty, a Return Goods Authorization number (RGA#) will be issued prior to the actual return of the parts. Please call the warranty department for this number if one was not been issued.
4. The RGA # must be clearly marked on the outside of the shipping box. Return transportation is the responsibility of the dealer.
5. The claim will be processed within 15 days of receipt of the returned parts. In some extenuating circumstances, it becomes necessary for returned parts to be further tested. In the event this happens, the dealer will be notified of the delay.

**THERE IS NO OTHER EXPRESS WARRANTY. ALL IMPLIED WARRANTIES OF MERCHANT LIABILITY AND FITNESS FOR USE ARE LIMITED TO THE DURATION OF THE EXPRESSED WARRANTY.**



Sweeper Co.

**IT IS EXPRESSLY UNDERSTOOD THAT STEWART-AMOS SWEEPER CO. WILL NOT BE LIABLE FOR ANY OTHER INJURY, LOSS, DAMAGE OR EXPENSE, WHETHER DIRECT OR CONSEQUENTIAL, INCLUDING BUT NOT LIMITED TO LOSS OF USE, INCOME, PROFIT OR PRODUCTION, OR INCREASED COST OF OPERATION, OR SPOILAGE OF OR DAMAGE TO MATERIAL, ARISING IN CONNECTION WITH THE SALE, INSTALLATION, USE OF, INABILITY TO USE, OR THE REPAIRS OR REPLACEMENT OF STEWART-AMOS SWEEPER CO.'S PRODUCTS.**

**STEWART-AMOS SWEEPER CO. RESERVES THE RIGHT TO MAKE CHANGES IN DESIGN OR TO MAKE ADDITIONS OR IMPROVEMENTS ON ITS PRODUCTS WITHOUT IMPOSING ANY OBLIGATION UPON ITSELF TO INSTALL THEM ON ITS PRODUCTS PREVIOUSLY MANUFACTURED.**

#### **RETURN OF GOODS AUTHORIZATION PROCEDURE**

1. If parts are required for a unit under warranty, they will initially be invoiced to the dealer. If Stewart-Amos Sweeper Co. requires the failed parts back for warranty evaluation, a Returned Goods Authorization number (RGA #) will be issued for the return of the parts.
2. The RGA # must appear on all shipping labels of parts being returned.
3. All parts returned must be shipped, freight prepaid. Stewart-Amos Sweeper Co. will allow 60 days from notification for all parts to be returned. After this date, the claim will be denied.
4. If you require an RGA # and one was not issued, please contact Stewart-Amos Sweeper Co. warranty department.







# General Specifications



## Serial Number Location

The Serial Number Identification Plate is easily found inside the cab on the drivers side rear corner panel. See *Figure 1*: below.

The Serial Number must be quoted whenever ordering parts, requiring technical support, or warranty. It ensures that you are assisted as efficiently and quickly as possible.



*Figure 1*: Serial Number Plate



**Engine (auxiliary)\***

Manufacturer:	Kubota
Model:	V2403-M-T-E
Displacement:	121.94 in <sup>3</sup>
Rated HP:	55 hp @ 2800 rpm
Alternator:	40 AMP
Configuration:	Inline – 4 cylinder

**Dirt Hopper**

Volumetric Capacity:	4.0 cu. Yards
Type of dump:	Left side dump
Maximum dump height:	10 ft. 4 in.
Minimum dump height:	18 in.
Dumping capacity:	8 000 lbs

**(It is not recommended to exceed maximum GVWR of chassis)**

**Elevator**

Squeegee-type system	
Hydraulic direct drive:	Variable speed and reversible

**Main Broom**

Mandrel:	Chevron Strip
Mandrel diameter:	11 in.
Mandrel length:	58 in.
Filled diameter:	36"
Segment material:	Polypropylene
Hydraulic direct drive:	Variable speed and reversible,

**Gutter Broom**

No. of brooms:	2
Diameter:	42 in.
No. of segments:	4 per broom
Hydraulic direct drive:	Variable speed and reversible
Broom adjustments:	Pressure & wear, side to side angle, front to back angle and sweep path width
Controls:	Up / down, forward / reverse
Design:	Free-floating spring suspension In-cab tilt (optional)



## Lighting System

- 2 – Halogen headlights, rectangular
- 2 – Stop/signal/tail lights on rear
- 2 – Turn signal lights on front
- Cab marker lamps and rear clearance lamps
- Warning beacon and Emergency flasher lamps
- Back-up lamps, automatic with audible alarm
- License plate lamp
- 2 – GB Lights
- 1 – Rear working light

## Hydraulic System

- |                         |                             |
|-------------------------|-----------------------------|
| Tank Capacity:          | 45 US. Gallons              |
| Pump:                   | Tandem gear                 |
| Pump Capacity:          | 10 gpm / 12 gpm @ 2 000 rpm |
| Controls:               | Electric over hydraulic     |
| Hydraulic drive motors: | All interchangeable         |
| Hydraulic fluid cooler: | Air to oil                  |

## Water System

- |                           |                            |
|---------------------------|----------------------------|
| Gutter broom spray system |                            |
| Tank capacity:            | 200 US. Gallons            |
| Tank material:            | Polyethylene               |
| Electric pump (1):        | 3.6 gpm                    |
| Water system material:    | All plastic, non-corrosive |

**For a complete list of specifications and options available, please contact your nearest dealer.**



# Controls



Refer to this section to quickly find out what each control does on the control panel. Do not use these controls however, until you have thoroughly read and understood the OPERATION Section. The OPERATION Section outlines how each control is to be used for safe operation.

(Refer to *Figure 2: Engine Control Box*)

The Control Box is generally located on a pedestal inside the cab. All Sweeper control buttons, rocker switches, and indicator-warning lamps are housed here. They are easily accessible to the driver from both left and right driving positions.

A brief description of the indicators and controls fitted in the Control Box are as follows:

### **Engine Controls**

(Refer to *Figure 2: Engine Control Box*)

1. Tachometer – Indicates the auxiliary engine RPM.
2. Hour Meter – Indicates the hours of operation of the auxiliary engine only.
3. Oil Pressure Gauge – Should the auxiliary engine oil pressure drop below the manufacturer specified minimum oil pressure of 69 kPa (10 psi), the automatic engine shut off system will be activated
4. Volt Meter – Measures the voltage of the batteries that are common with the chassis. The chassis may also have a volt meter or an amp meter.
5. Coolant Temperature Gauge – If the auxiliary engine coolant temperature rises above 100<sup>0</sup> C (212<sup>0</sup> F) the automatic engine shut off system will be activated.
6. Ignition Key Switch – This main power switch starts the auxiliary engine enabling all sweeping functions. (See “Operating Auxiliary Engine”).
  - a. **Glow Plug Position** – Turn the starter switch to the “PREHEATING” position to allow the glow lamp to redden. The glow lamp goes out in about 30 seconds when the lamp timer is up. Even with the glow lamp off, the glow plug can be pre-heated by turning the starter switch to the “PREHEATING” position. Turn the key to the “START” position and the engine should start. Release the key immediately when the engine starts. The following table shows the standard preheating times for various temperatures. This operation is not required when the engine is warmed up.
  - b. **Start Position** - Turn ignition key to the start position to start auxiliary engine. When engine starts release key and switch will automatically return to the run position. If engine does not start within 15 seconds of turning starter over, return to step 2.



Figure 2: Engine Control Box



## Sweeper Controls

Refer to *Figure 3: Sweeper Control Box*

1. **LH GUTTER BROOM TILT UP / DOWN** – This function is used to clean out deep gutters or depressions in the sweeping surface. When the switch is pressed to the LH GUTTER BROOM TILT DOWN position, the gutter broom will pivot down on the inside of the brush plate. When the switch is pressed to the LH GUTTER BROOM TILT UP position, the gutter broom will pivot up on the inside of the brush plate.
2. **BEACON LIGHT ON** – Turns both the front and back strobe light on and off.
3. **RH GUTTER BROOM TILT UP / DOWN** - This function is used to clean out deep gutters or depressions in the sweeping surface. When the switch is pressed to the RH GUTTER BROOM TILT DOWN position, the gutter broom will pivot down on the inside of the brush plate. When the switch is pressed to the RH GUTTER BROOM TILT UP position, the gutter broom will pivot up on the inside of the brush plate.
4. **BROOMS UP/DOWN** – This switch lifts/lowers the rear broom and elevator and must be pushed and held in the up/down position until the function is complete. To lower, push down and hold the switch until rear broom is fully down, then release. When the brooms are fully down, the hydraulic cylinders will bottom and pull the engine rpm down as the hydraulic oil is dumped over the relief valve. The gutter brooms will lift/lower with the rear broom if they are activated (see: LH / RH GUTTER BROOM UP / DOWN SWITCHES). The switch is interlocked through a proximity switch with the HOPPER UP/DOWN function to prevent the hopper from interfering with the elevator and will not function unless the light in the center of the switch is on. When the brooms are down they are designed to float to accommodate uneven pavement.
5. **GB LIGHTS ON / GB/MB LIGHTS ON** – This is a three-position switch which controls both gutter broom lights and main broom lights. When switch is in the “GB LIGHTS ON” position both gutter broom working lights will be on. When the switch is in the “GB/MB LIGHTS ON” position both gutter broom lights as well as the rear main broom work light will be on. When the switch is in the middle position all working lights will be off.
6. **SWEEP FORWARD / SWEEP REVERSE** – This switch controls the direction of rotation of all brooms and the elevator. The switch is interlocked through a proximity switch with the BROOMS UP/DOWN function to prevent the brooms from rotating without being lowered and will not function unless the light in the center of the switch is on. When the switch is in the “SWEEP FORWARD” position the gutter brooms, if they are activated (see: LH / RH GUTTER BROOM UP / DOWN SWITCHES), will rotate vertically so that the leading edge of the brooms move material to the center of the machine, the rear main broom will rotate horizontally against the direction of travel which throws the material into the elevator. The elevator rotates dragging the material up the floor and depositing it in the hopper. When the switch is in the “SWEEP REVERSE” position all brooms and elevator will rotate in the opposite directions. The “SWEEP REVERSE” function dislodges any material that may have obstructed the elevator and





- sweep large objects out of the sweeping path that may be too large to sweep. This switch will not function unless the light in the center of the switch is on.
7. **HOPPER UP / DOWN** – This switch controls the hopper up and down function. To raise the hopper, press and hold the spring-loaded switch to the “HOPPER UP” position. To lower the hopper, press the switch to the “HOPPER DOWN” position. If the switch is not being depressed it will automatically return to the center or hold position. The hopper will maintain its current position if the switch is not depressed in either direction. This switch will not function unless the light in the center of the switch is on. The switch is interlocked through a proximity switch with the BROOMS UP/DOWN function to prevent the hopper from raising without having the brooms up and will not function unless the light in the center of the switch is on. This is to protect the hopper from interfering with the elevator.
  8. **WATER** – This switch controls the water used for dust control. When the switch is in the up position, the water pump will go on and off with the sweep forward function to extend water supply. When the switch is in the down position the water pump will be on continuous function.
  9. **HOPPER DUMP / RETRACT** – This switch controls the hopper dumping function. The hopper can be dumped at any height in the lift cycle. When the hopper has been raised to the desired height, press and hold the switch in the “HOPPER DUMP” position until the hopper is fully tipped with the door open. To return the hopper to the retracted position press and hold the switch in the “HOPPER RETRACT” position until the hopper is fully retracted. At any time in the dumping cycle the switch can be released and the hopper will hold that position. The switch is interlocked through a proximity switch with the BROOMS UP/DOWN function to prevent the hopper from interfering with the elevator function. This switch will not function unless the light in the center of the switch is on.
  10. **LH GUTTER BROOM UP / DOWN** – This switch controls the independent operation of the left hand gutter broom only. When the switch is in the center position the gutter broom will stay up when the rear main broom is lowered. When the switch is in the “LH GUTTER BROOM DOWN” position the gutter broom will go up/down and turn on/off with the rear main broom. When the rear main broom is down and the gutter broom is operating in the lowered position and you wish to turn off the left gutter broom only, push and hold the switch to the “LH GUTTER BROOM UP” position until the gutter broom is fully up then release the switch. When the switch is released the gutter broom rotation will stop and the switch will automatically return to the center position.
  11. **RH GUTTER BROOM UP / DOWN** – This switch controls the independent operation of the right hand gutter broom only. When the switch is in the center position the gutter broom will stay up when the rear main broom is lowered. When the switch is in the “RH GUTTER BROOM DOWN” position the gutter broom will go up/down and turn on/off with the rear main broom. When the rear main broom is down and the gutter broom is operating in the lowered position and you wish to turn off the right gutter broom only, push and hold the switch to the “RH GUTTER BROOM UP” position until the gutter broom is fully up then release the switch. When the switch is released the gutter broom rotation will stop and the switch will automatically return to the center position.



**STEWART-AMOS**

Sweeper Co.

12. **ELECTRIC THROTTLE** – Available as standard equipment on SN 7980 & up. Push switch up to increase auxiliary engine rpm and down to reduce rpm.

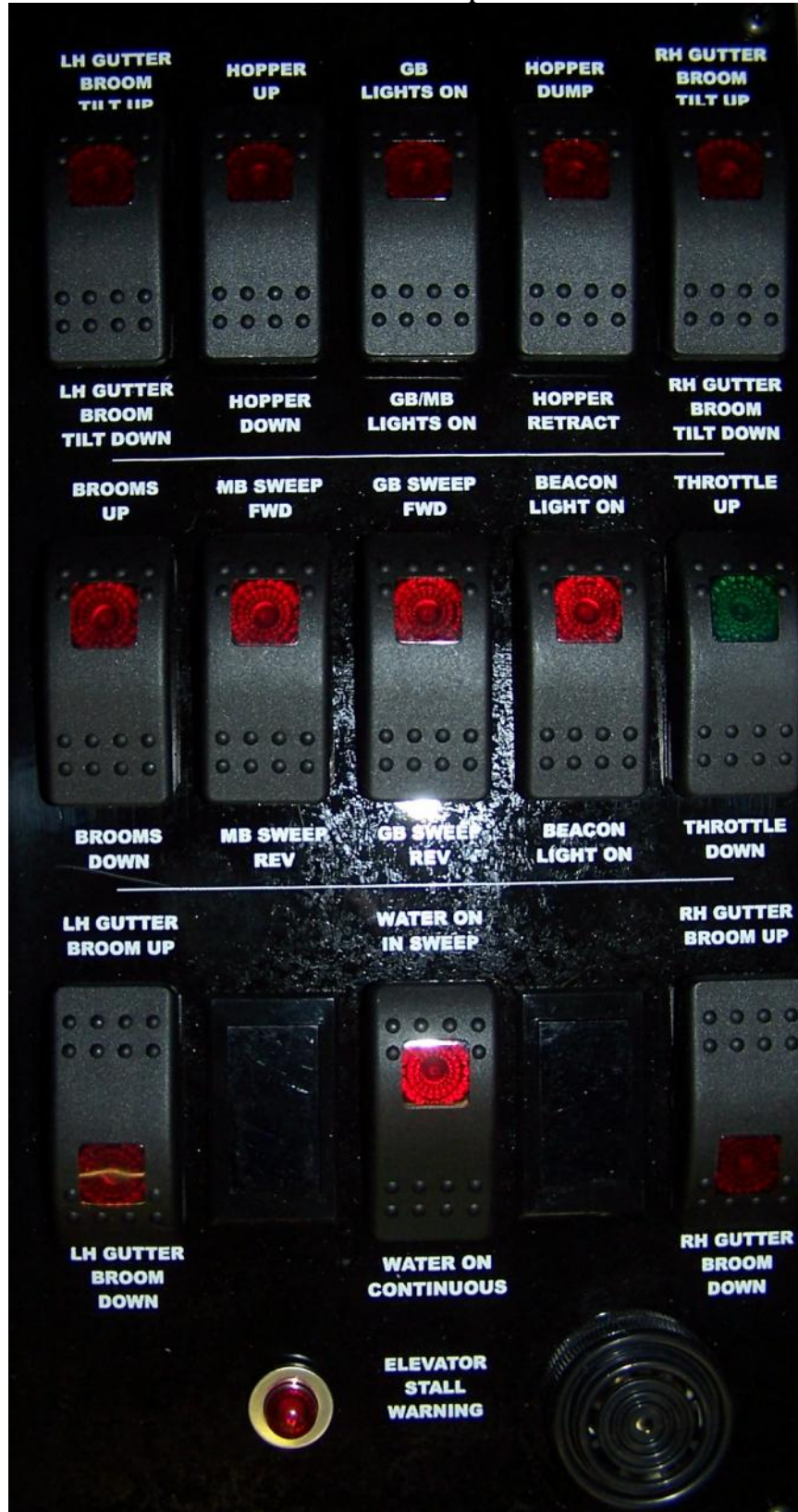

Figure 3: Sweeper Control Box to SN 4011 and up





# Operation

## Auxiliary Engine

**IMPORTANT:** Before starting the auxiliary engine, check the SERVICE section in this manual and perform scheduled maintenance for the required service period.

1. Read the auxiliary engine instruction manual before operating engine.
2. Check the auxiliary engine fuel, oil, coolant, and hydraulic oil levels.
3. Make sure that all sweeper control switches are in the neutral positions and the park brake is engaged.
4. Turn the starter key to the start position and release as soon as the engine starts. Do not crank engine for more than 10 seconds at a time or starter damage may occur.
5. If the engine does not start on the first try, wait for 30 seconds before trying again.
6. Once the engine is running, check the gauges. Allow the engine to warm up at 1000 rpm for 10 minutes.

**IMPORTANT:** When the auxiliary engine is no longer required to run the sweeper controls, let the engine run at low idle for three to five minutes before shutting the engine off. This allows the engine to properly cool.



**CAUTION: If the engine stalls during normal operation, restart it immediately to prevent excessive heat build up.**

- Recommended engine speed on normal street sweepings is 2000 – 2400 rpm.
- Minimum oil pressure is 15 psi at 700 rpm at normal operating temperature.
- Normal engine coolant temperature is 180<sup>0</sup> – 202<sup>0</sup> F).

**NOTE:** It is a good practice to operate the engine under a lighter load and at lower speeds for the first 30 minutes after start up.

## Water Fill Up

(Refer to Figure 4: Water Tank)

1. The water tank can be filled with a hydrant hose at the main fill location (B).

**IMPORTANT:** The water tank is equipped with a 3" air gap to help prevent damage to the water tank when filling from a hydrant as well as siphoning back to hydrant. However, care must be taken when filling from a high-pressure source.

2. From curb side open the water shut off (C). Access to the valve is gained through the right rear canopy door on the sweeper.
3. After filling the water tank, close valve (C) to close the canopy door. This prevents dirt from accumulating in water tank.

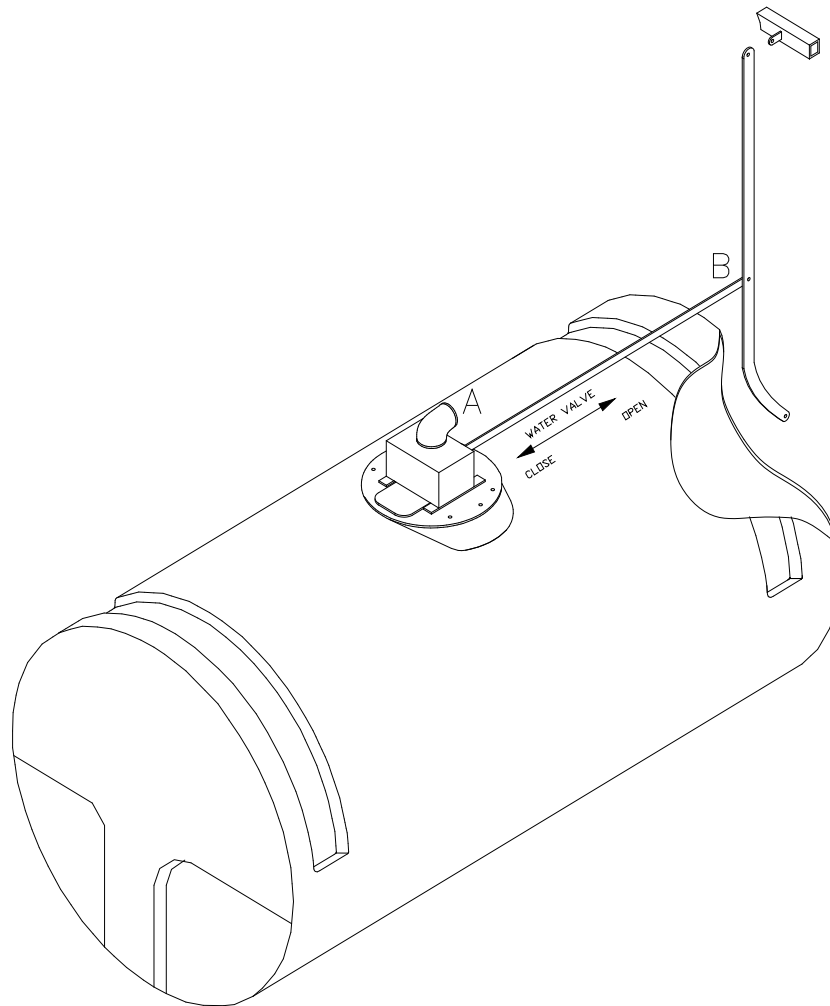

*Figure 4: Water Tank*

## Sweeping

1. With the engine idling, ensure the hopper is fully lowered by depressing the HOPPER UP/DOWN switch to the “DOWN” position.
2. Run the auxiliary engine up to 2000 – 2400 rpm. This is the rpm range for normal street sweepings.
3. Lower the brooms and elevator into sweeping position by depressing the BROOMS UP/DOWN switch to the “DOWN” location.
4. Press the SWEEP FORWARD switch to the “FORWARD” sweep position. The gutter brooms and main broom will begin turning.
5. For dust control suppression press the WATER ON switch to the “ON” position. The water pump will begin operating to activate pressure spray to the front/rear spray bar and the gutter broom nozzles.



**WARNING: Ensure all observers are clear of the sweeper at a minimum, distance of 10 feet.**

**NOTE:** If the main broom and/or elevator become plugged with debris, push the SWEEP FORWARD /REVERSE switch to the centre position. Then reverse the rotation by holding the switch in the “REVERSE” position. Once the main broom and elevator are free of debris, release the switch.

**NOTE:** When sweeping is extremely heavy, it is advisable to sweep with the truck moving as slow as possible.



**WARNING: It is unlawful to exceed the GVWR of the chassis. Care must be taken not to, overloading conditions will also void warranty.**



## Dumping

**IMPORTANT:** When the hopper is full, it must be dumped before sweeping can continue.

1. Push the SWEEP switch to the centre position to stop all rotation of the gutter brooms and main broom. Then lift the brooms and elevator by depressing the BROOMS UP/DOWN switch to the “UP” position. Do not operate the hopper until all brooms are lifted and are secure. Return the SPRAY switch to the centre position to turn off the water pump.
2. Drive to an appropriate level and stable dump area.



**WARNING: The sweeper must be positioned on level and stable ground while dumping to prevent serious injury or damage. If raising and dumping the hopper is not done on level and stable ground, the lifting arms, frame and canopies may be damaged. Failures resulting from the machine being dumped on uneven ground will void the warranty.**



**WARNING: Never MOVE vehicle while dumping.**  
**WARNING: Always check BEHIND and ABOVE sweeper before backing up or raising the hopper! Serious damage may result otherwise.**

**WARNING: Never use hopper safeties with material in the hopper. Safeties will not hold a loaded hopper.**

3. When in position, place the sweeper transmission lever in neutral and engage the parking brake.
4. Elevate the hopper by pressing the HOPPER RAISE/LOWER switch to the “RAISE” position until the desired height is reached.

**NOTE:** The hopper is capable of being dumped at any height and can be raised or lowered while dumping, provided the sweeper is being operated on level ground.

5. Tilt the hopper to dump its contents by pressing the HOPPER DUMP/RETRACT switch to the “DUMP” position.
6. When the hopper is empty, return it back to its home position by retracting the hopper using the HOPPER DUMP/RETRACT switch and lowering the hopper with the HOPPER RAISE/LOWER switch.
7. To resume sweeping, lower brooms and elevator into sweeping position with the BROOMS UP/DOWN switch, press the SWEEP switch to the “FWD” position, and turn on the dust control system with the SPRAY switch, if desired.

**REMINDER:** At night, the Main Broom light may be used to assist in backing up.

NOT A SAFE HOPPER LIFT AND/OR DUMP ANGLE

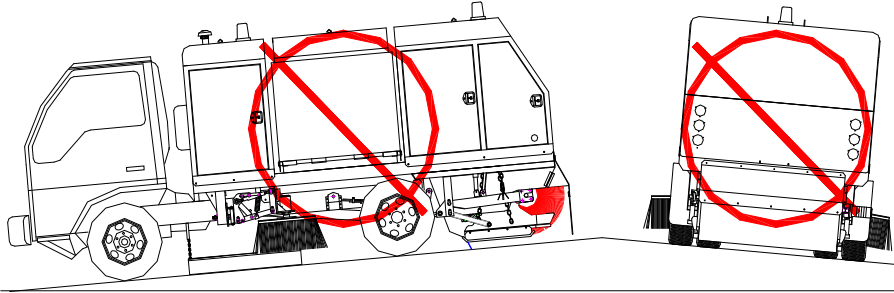

NOT A SAFE HOPPER LIFT AND/OR DUMP ANGLE

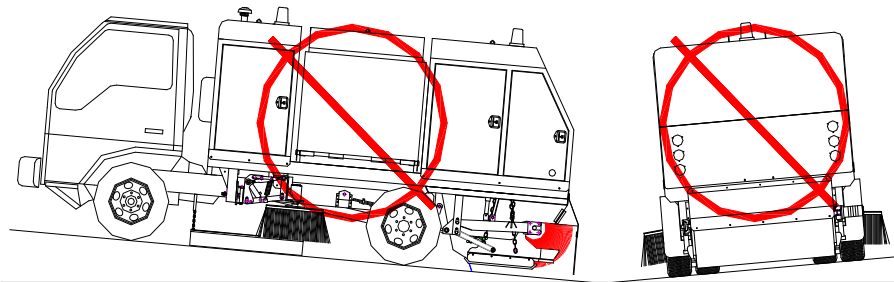

SAFE HOPPER LIFT AND/OR DUMP ANGLE

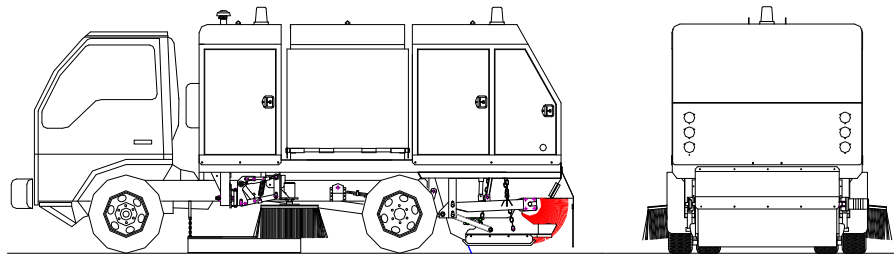



## **Engine Break-In**

For engine break-in please refer to the auxiliary engine Operator's Manual.

## **Sweeper Break-In**

After the first 8 hours of operation.

1. Check and tighten:
  - a. Suspension bolts
  - b. Main broom coupler
  - c. Broom bolts
  - d. Elevator bolts
  - e. Set screws
  - f. Wheel nuts

For every 25 hours for the first 100 hours.

1. Check and tighten:
  - g. Suspension bolts
  - h. Main broom coupler
  - i. Broom bolts
  - j. Elevator bolts
  - k. Set screws
  - l. Wheel nuts
2. Inspect all areas of sweeper periodically to ensure long term life and reliability. Practicing regular routine maintenance will payback in minimal operating costs and less down time over the life of the machine.



## Winterizing Your S – 4 Sweeper

1. Remove dust suppression water filter, allow as much water as possible to drain from the system and replace water canister without filter.
2. Remove water line coming from the tank at the filter.
3. With water pump running, pressurize the filter housing by using compressed air. This removes water from the pump and lines preventing the water from freezing and rupturing water lines or the pump. Continue blowing air into the filter housing until all nozzles blow air.
4. Remove dust suppression water filter canister and leave off for winter.
5. If sweeping in winter months, do not use water system if below freezing temperatures. If water system is used, it must be purged, using the method stated above before temperature drops below freezing.
6. Engine – Maintain and service engine as per the engine manual provided with the unit.
7. Check antifreeze strength. Must be good for -35<sup>0</sup> F.
8. Insure all fluid levels at maximum of the operating range.
9. Clean or change engine air filter before parking for winter.
10. Maintain and service chassis as per the owners manual provided with unit.

## Service

### Fuel, Lubricants, and Coolants

#### Diesel Fuel

(Refer to the original engine manufacturer's recommendations).

Use ASTM No. 2-D grade fuel when outside air temperature is above 50° C (40° F).

Use ASTM No. 1-D grade diesel fuel when outside air temperature is below 5° C (40° F).

**IMPORTANT:** Do NOT use fuel that is contaminated by water and dirt!



**WARNING: Be careful when handling fuel! Never fill the tank when the engine is hot or running! Do not smoke while filling the fuel tank!**

#### Diesel Engine Oil

(Refer to the original engine manufacturer's recommendations).

#### Coolant

(Refer to the original engine manufacturer's recommendations).

50% water and 50% ethylene glycol base antifreeze should be used year round.



**WARNING: Use extreme care when removing radiator filler caps. Remove only when coolant temperature is below the boiling point.**

#### Hydraulic Oil

The recommended hydraulic oil for this sweeper **Exxon Hydraulic H 68** or equivalent. Failure to do so **WILL** void warranty.

The hydraulic system is very susceptible to contamination from both dirt and moisture and is designed to use a system breather which must be kept clean.



**CAUTION: The entire hydraulic oil system must be of the same viscosity grade.**

## Grease

The recommended grease for this sweeper is **Whitmore Novagard EP 2** multipurpose grease or equivalent.

## Lubrication and Maintenance

**IMPORTANT:** Maintenance includes inspection and replacement of worn parts as required.



**WARNING: Before servicing the sweeper follow a proper Equipment Lockout procedure as described in the Safety section. Serious personal injury or death may result otherwise!**

**NOTE:** To service the chassis or auxiliary engine, refer to the manufacturer's manual included with your sweeper.

For Auxiliary Engine service locations, see Figure 5: Service Locations on Auxiliary Engine

## Daily

(Refer also to the engine manual that comes with your sweeper for locations).

1. Check oil and coolant levels on the engine.
2. Do a walk around inspection to check all linkages cotter pins and bolts for looseness or missing.
3. Check hydraulic oil level in the hydraulic oil tank. The sight glass is located on the front of the hydraulic oil tank on the driver's side of the vehicle.
4. Check the hydraulic oil breather filter, located on tank, for cleanliness.
5. Inspect the Air Restriction Indicator on the engine air filter. For longer engine life it is strongly recommended to change the air filter element at regular intervals. The Air Restriction Indicator gives you a guideline of when changing is needed.
6. Lubricate the elevator bearings.
7. Lubricate the main broom bearing.



**WARNING: Do not pull on hydraulic oil cooler outlet hose when servicing. This may cause the cooler to leak.**

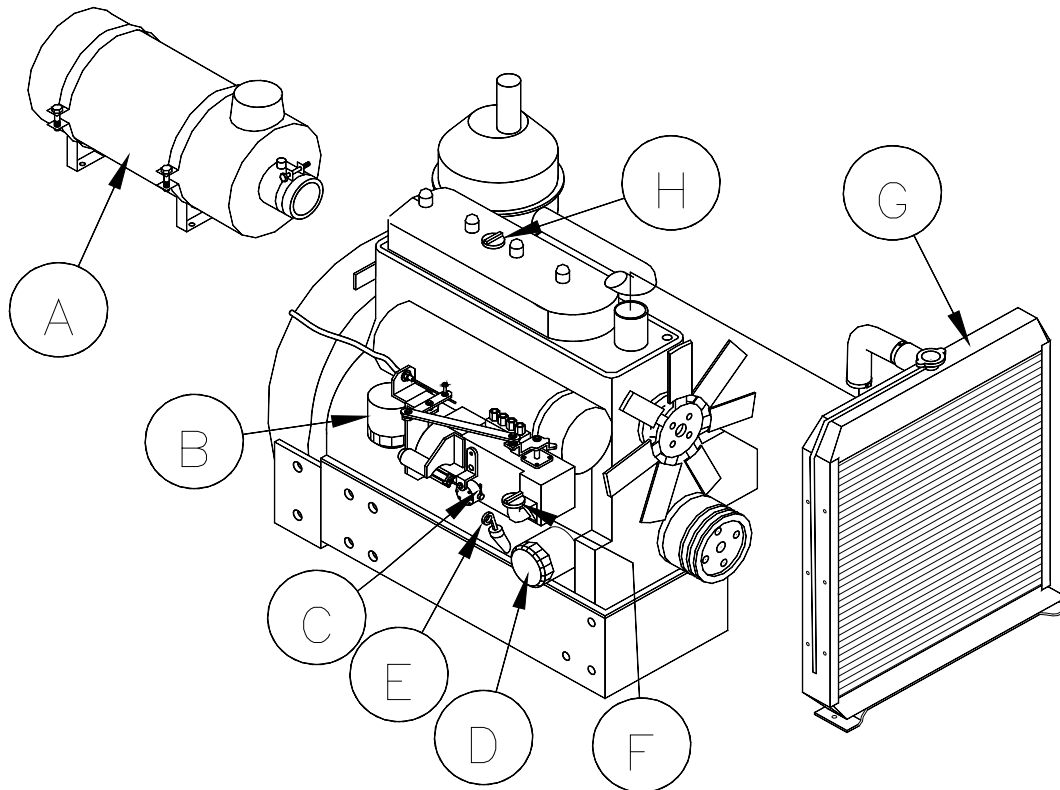

- |                      |                        |
|----------------------|------------------------|
| 1. Air Filter        | 5. Engine Oil Dipstick |
| 2. Fuel Filter       | 6. Engine Oil Fill Cap |
| 3. Fuel Primer Pump  | 7. Coolant Fill Cap    |
| 4. Engine Oil Filter | 8. Engine Oil Fill Cap |

*Figure 5: Service Locations on Auxiliary Engine*

### Every 40 Hours

1. Clean the dust control water filter and inspect the sprayer nozzles.
2. Check the radiator for plugging. Ensure radiator is cool before cleaning. Clean with fresh water.
3. Replace the engine oil in the auxiliary engine (initial change only).
4. Replace the hydraulic oil filter in the auxiliary engine (initial change only).
5. Lubricate gutter broom pivot points.
6. Lubricate main broom arms.
7. Lubricate drag shoe links.

### Every 250 Hours

1. Replace the hydraulic oil filter.
2. Replace the oil breather filter.
3. Replace the auxiliary engine oil and filter.



### Every 500 Hours

1. Replace the hydraulic oil filter.
2. Replace the hydraulic oil breather filter.

**NOTE:** It is advised to use only factory replacement oil filters. All replacement filters must meet or exceed 10 micron absolute rating. Failure to meet or exceed these specifications will void the warranty.

3. Visually inspect the hydraulic system.
4. Check all lines and hoses for cracks or wear and replace as required.
5. Check all fittings for leakage and retighten or replace if necessary.
6. Check all components for possible wear and have them serviced if necessary.

### Every 1000 Hours

Replace Hydraulic Oil, Oil Breather Filter, and Hydraulic Oil Filter as follows:

1. Run the sweeper until hydraulic oil is warm.
2. Stop the engine.
3. Remove both magnetic drain plugs from the bottom of the oil reservoir (one on each side). Drain the oil into a large container.
4. Clean and reinstall both magnetic drain plugs.
5. Replace the reservoir breather filter.
6. Replace the hydraulic filter.
7. Fill reservoir with hydraulic oil as recommended from the pump manufacturer.

**IMPORTANT:** If Hydraulic Oil is replaced due to contamination, it is imperative to **DISMANTLE AND THOROUGHLY CLEAN** the hydraulic reservoir, lines and hoses, all other components, and flush the entire hydraulic system before new oil is added!

8. Run the sweeper for several minutes and check for leaks. (Actuate all cylinder circuits and run all motor circuits).
9. Add oil as required. Oil level should be above low level sight glass.

**Refer to the Lubrication and Maintenance Check List at the end of the manual.**





## **Gutter Broom Angle Adjustments**

(Refer to *Figure 6: Gutter Broom Assembly*) also  
(Refer to *Figure 7: Gutter Broom Pattern*)

The proper tilt angle must be maintained for effective sweeping. If the broom is set too flat, it will tend to throw debris back to the curb. If the broom angles are too great, streaks of debris will be left on the pavement.

### **Correct Gutter Broom Angle**

The broom angles are correct when the front outside 1/3 of the broom contacts the pavement. With the brooms fully lowered, ensure the gutter broom pattern overlaps the main broom pattern. This setting is met when the brooms are adjusted between 3° - 5° tilt angle.

The attack angles of the brooms are adjustable as well but are set at the factory and should not require further adjustment except for special applications. Only the tilt angle may need modification from time to time. The attack angle should be set to 3° - 5° for normal sweeping.

### **Adjust Tilt Angle**

(Refer to *Figure 6: Gutter Broom Assembly*) also  
(Refer to *Figure 7: Gutter Broom Pattern*)

1. Loosen angle adjustment lock nut (B) to allow movement of the angle adjustment turnbuckle (C).
2. To increase the tilt angle of the gutter brooms, decrease the length of turnbuckle (C). To decrease the angle, lengthen turnbuckle (C).
3. Once the proper tilt angle is achieved, tighten angle adjustment lock nut (B) to secure brooms.

### **Adjust Front to Back Angle**

(Refer to *Figure 7: Gutter Broom Pattern*)

1. Loosen lock nut on adjustment turnbuckle (L) to allow movement of the lower section of the gutter broom.
2. To increase the forward attack angle of the broom to the sweeping surface, turnbuckle must be shortened. To decrease the attack angle or flatten the broom, turnbuckle must be lengthened. The attack angle should be set to 30 – 50 for normal sweeping.
3. Once the correct angle is adjusted, make sure the turnbuckle lock nut is tightened.



## Gutter Broom Pressure

Proper broom pressure is very important. Low broom pressure will cause poor sweeping. High broom pressure will cause excessive broom wear.

**IMPORTANT:** Be sure gutter broom angle is correct before setting gutter broom pressure.

## Correct Gutter Broom Pressure

1. Lower brooms onto the road surface and have them rotate with the sweeper stationary.
2. Stop and raise the brooms.
3. Drive sweeper off the swept pattern.
4. Inspect the pattern: If the gutter broom pressure adjustment is correct, the front outside 1/3 of the broom must be in contact with the road surface.

## Adjust Gutter Broom Pressure

(Refer to *Figure 6: Gutter Broom Assembly*)

1. Loosen turnbuckle lock nut (I) on suspension turnbuckle (H).
2. To increase down pressure on gutter broom lengthen the turnbuckle, to reduce down pressure shorten the turnbuckle. By lengthening or shortening the turnbuckle will affect spring (D) which increases or lowers gutter broom pressure to compensate for wear.
3. Tighten lock nut (I) on suspension turnbuckle (H)

## Sweeping Width

(Refer to *Figure 6: Gutter Broom Assembly*) also

(Refer to *Figure 7: Gutter Broom Pattern*)

The sweeping path width can be adjusted for a broader or narrower sweeping path.

**NOTE:** The wider the sweeping path the greater the possibility of damaging the broom linkages from impacts.

Tighten bolt (K) to decrease the sweeping path and loosen to increase sweeping path.

**NOTE:** The wider the sweeping path the greater the possibility of streaking between the rear broom and the main broom. A sufficient gutter broom to main broom overlap must be maintained.



## **Gutter Broom Impact Protection Spring**

(Refer to *Figure 6: Gutter Broom Assembly*) also  
(Refer to *Figure 7: Gutter Broom Pattern*)

Each gutter broom is equipped with an impact protection spring (A) to protect it from side impact damage. There is no adjustment for this spring.

**NOTE:** The wider the sweeping path the greater the possibility of damaging the broom linkages from impacts.

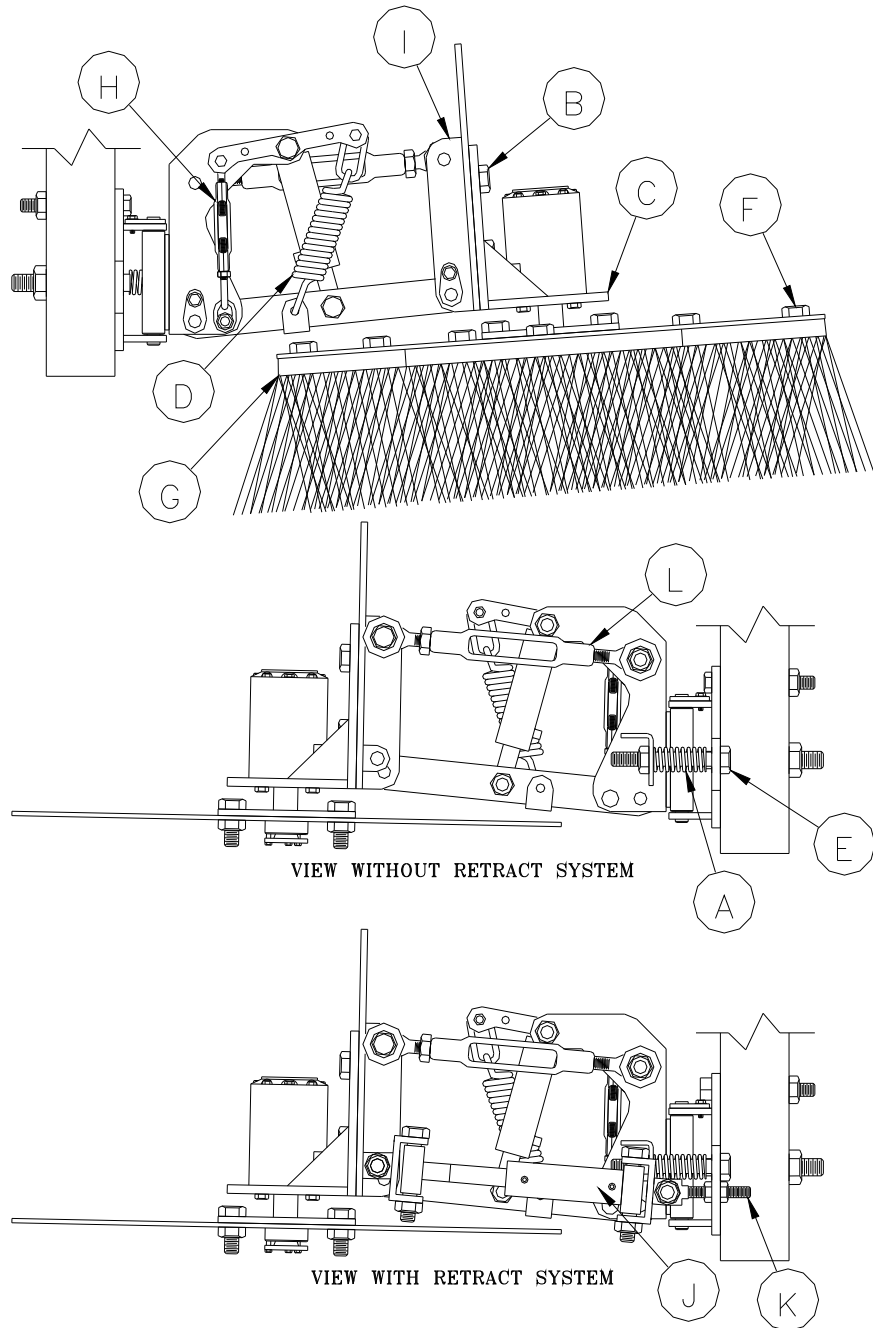

- |                              |                                |
|------------------------------|--------------------------------|
| A. IMPACT SUPPRESSION SPRING | G. BRUSH SEGMENTS              |
| B. SIDE TILT ADJUSTMENT BOLT | H. SUSPENSION ADJ. TURNBUCKLE  |
| C. MOTOR BRACKET             | I. LINKAGE MOUNT               |
| D. SUSPENSION SPRING         | J. RETRACT CYLINDER            |
| E. PATH WIDTH ADJ. BOLT      | K. RETRACT ADJ. BOLT           |
| F. SEGMENT RETAINING BOLTS   | L. FRONT/BACK ANGLE TURNBUCKLE |

**Figure 6: Gutter Broom Assembly**

FRONT OF SWEEPER

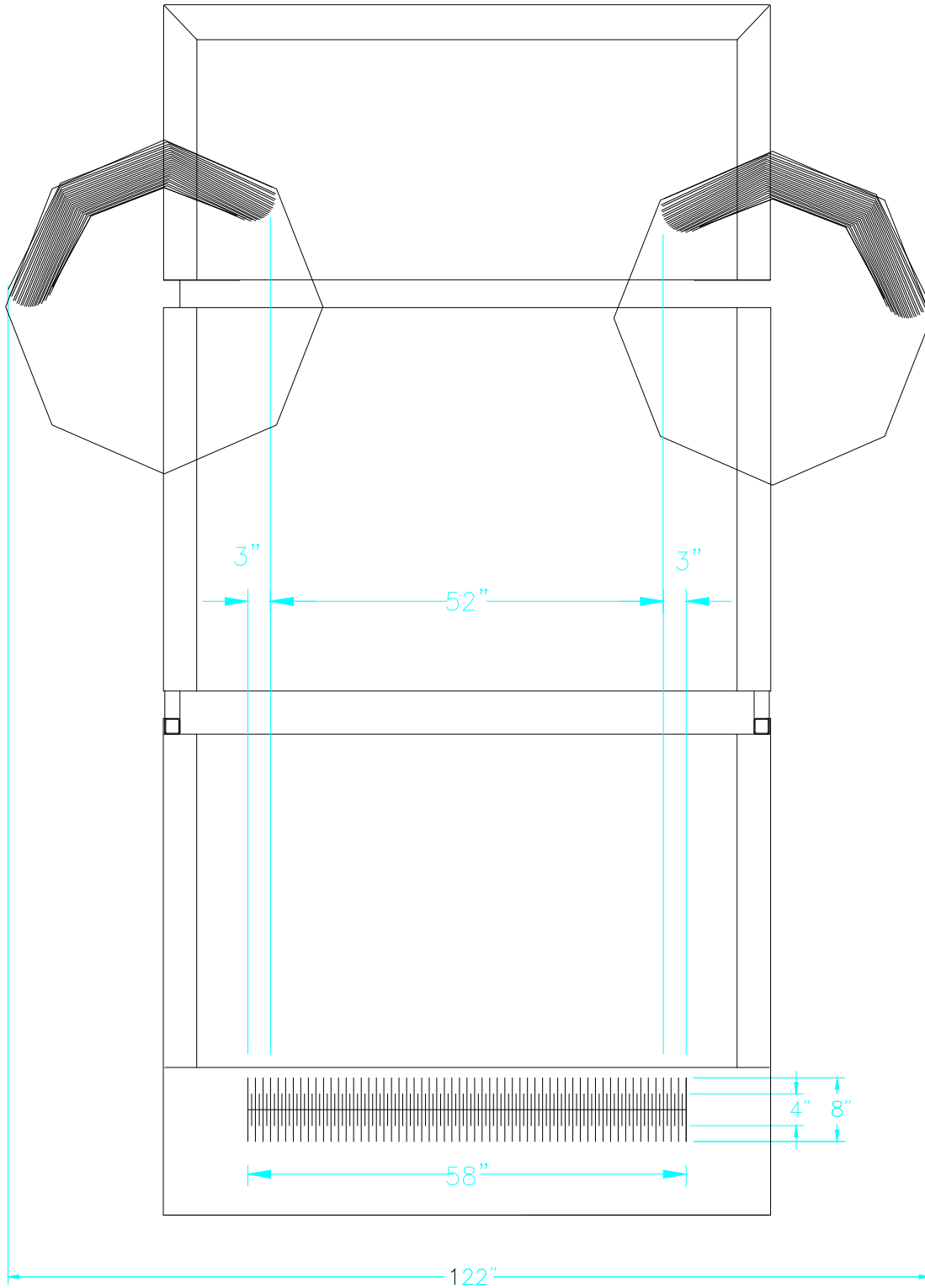

Figure 7: Correct Broom Pattern

## Main Broom Pressure

(Refer to *Figure 8: Main Broom Assembly*)

The main broom pressure is controlled by the tension on the suspension spring (F) while the shock absorber (E) applies down pressure. To adjust the down pressure:

1. Loosen the lock nut on turnbuckle (D).
2. Lengthen the turnbuckle to increase the down pressure and shorten the turnbuckle to decrease down pressure.

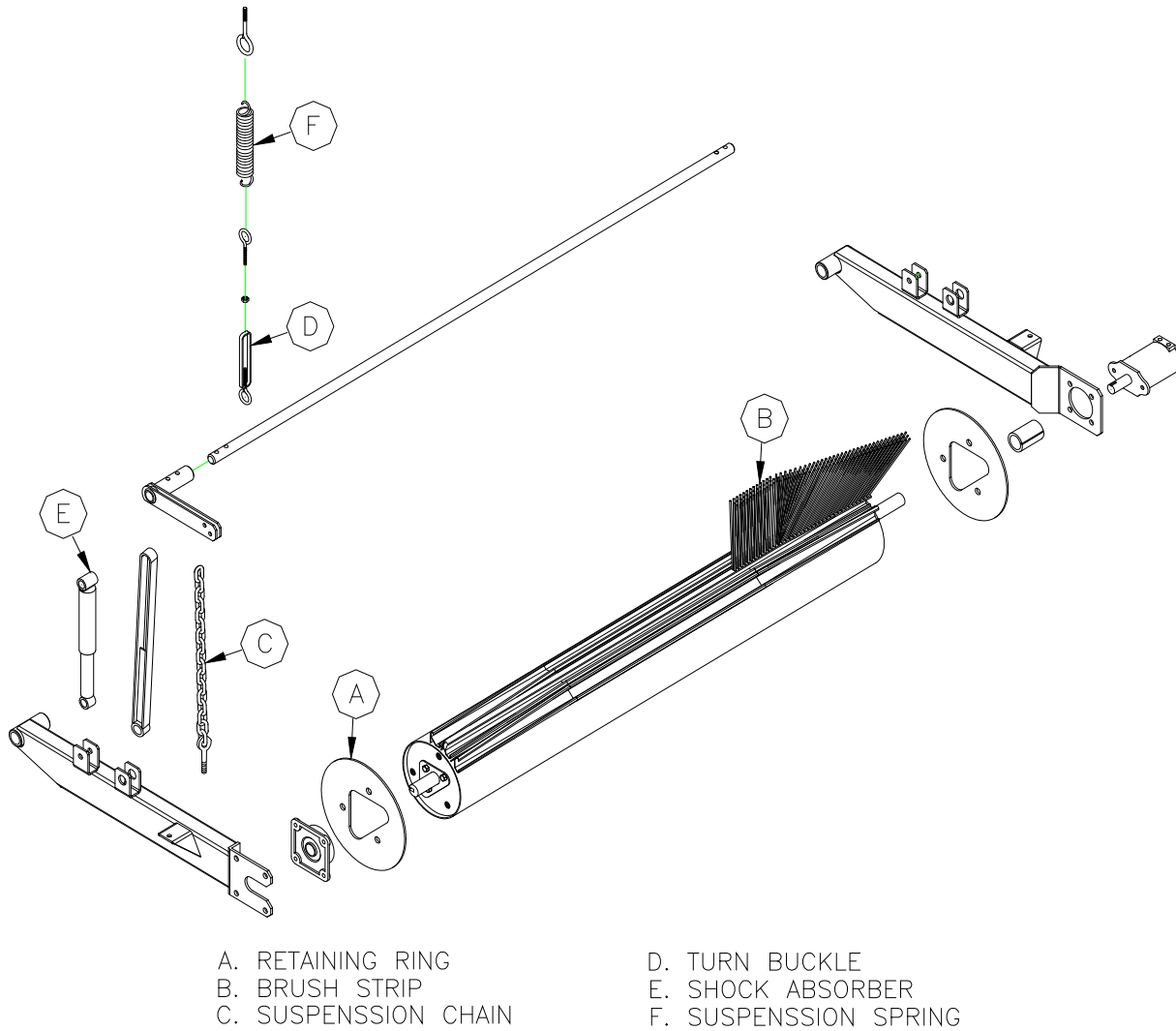

*Figure 8: Main Broom Assembly*

## Elevator Chain Adjustment

### Upper Drive Shaft

(Refer to *Figure 13*: Elevator)

1. Loosen bolts (C).
2. Loosen lock nut (E).
3. Tighten adjustment bolt (D).

**NOTE:** Bottom shaft and bearings (P) should never require adjusting. This shaft is preset at the factory.

**NOTE:** Elevator chains should always be run **as loose as possible once in operation**, without rubbing on each other or the separator bar.

**NOTE:** Always adjust upper drive shaft first. When upper shaft has moved to the end of its travel then center shaft can be adjusted.

**NOTE:** Slide (A) has limited travel because of bolts on bearing (B). Slide (A) will only move as far as bolts on bearing (B) come to the end of the travel.

4. Once bolt (D) has been adjusted, tighten lock nut (E).
5. Tighten bolts (C).

### Center Idler Shaft

1. Loosen bolts on bearing (H).
2. Loosen lock nut (G).
3. Tighten bolt (F) until desired chain tension is reached.
4. Tighten bolts on bearing (H).
5. Tighten lock nut (G).

**NOTE:** The correct tension on **new elevator chain and sprockets only** is 1-3” deflection on the chain between shaft (L) and shaft (J).

**NOTE:** Partially **worn chain and sprockets** should be run **as loose as possible** between shaft (L) and shaft (J). **Chains that are being run to tight will have excessive wear and create excessive load on the elevator.**

**NOTE:** If all the adjustment has been used and the chain is still loose, a ½ or 1 full link may have to be removed by loosening the shaft adjustments, remove a link and readjust the shafts using the procedure above.

(Refer to *Figure 9*: Elevator Chain Adjustment)

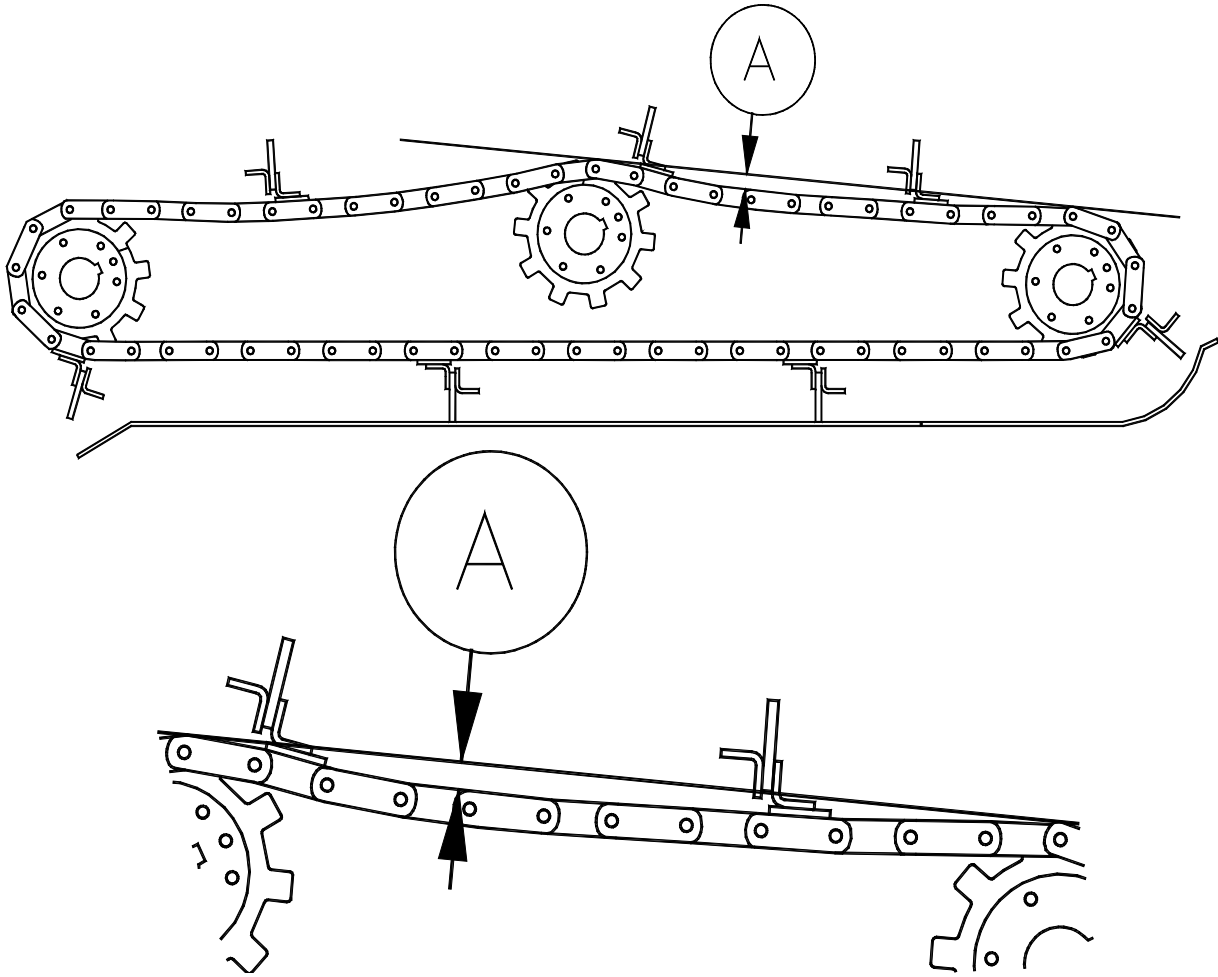

Refer to *Figure 9: Elevator Chain Adjustment*





# REPAIR AND MAINTENANCE



## **Gutter Broom Segment Replacement**

(Refer to *Figure 6: Gutter Broom Assembly*)

1. Fully raise brooms.
2. Remove bolts (F) that hold broom segments (G) in place.
3. Bolt new broom segments in place.
4. Repeat this procedure for all segments.
5. After installing new segments, gutter broom pressure must be reset as per Gutter Broom Pressure Adjustment.

## **Main Broom Strip Replacement**

(Refer to *Figure 10: Main Broom Assembly*)

1. Main broom must be raised for this operation so broom can be rotated.
2. Remove 3 bolts holding retaining ring (A) to the mandrel (B).
3. Lower retaining ring (A) onto the mandrel end shaft.
4. Pull worn broom strips out the side of machine.
5. Clean the C-channel before inserting the new strips.
6. As each strip is removed from the mandrel, immediately replace with a new strip, this keeps the mandrel in balance and is easier to rotate to the next strip. Ensure the new broom strips slide into the C-channel. If strip is tight in the C-channel, penetrating oil can be used to lubricate the strips as they go in.

**NOTE:** Eighteen broom strips are required to complete the main broom.

7. After all strips have been replaced, reinstall retaining ring (A) onto the mandrel (B).

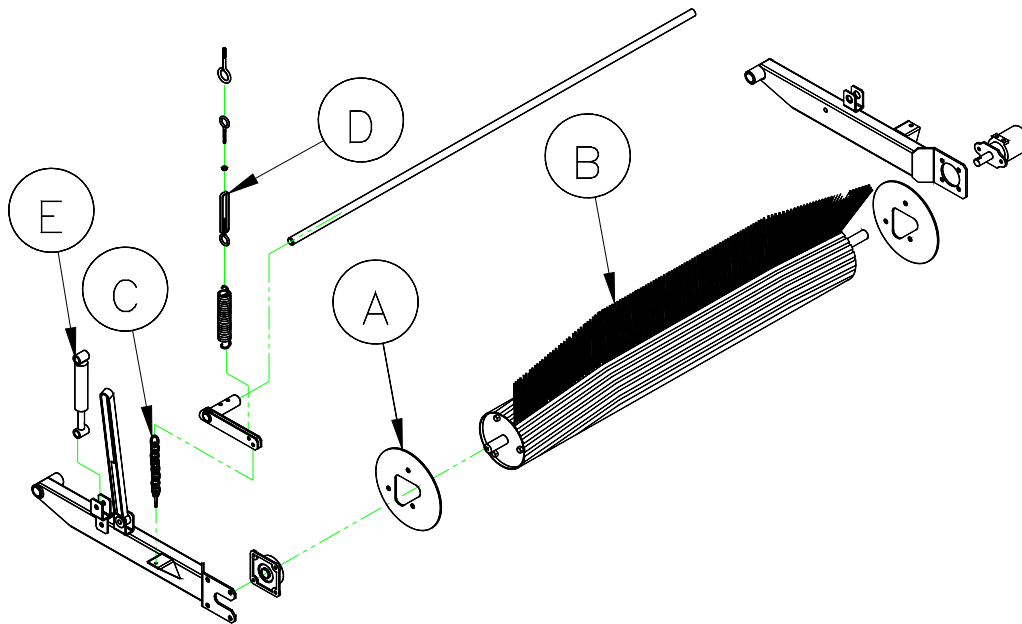
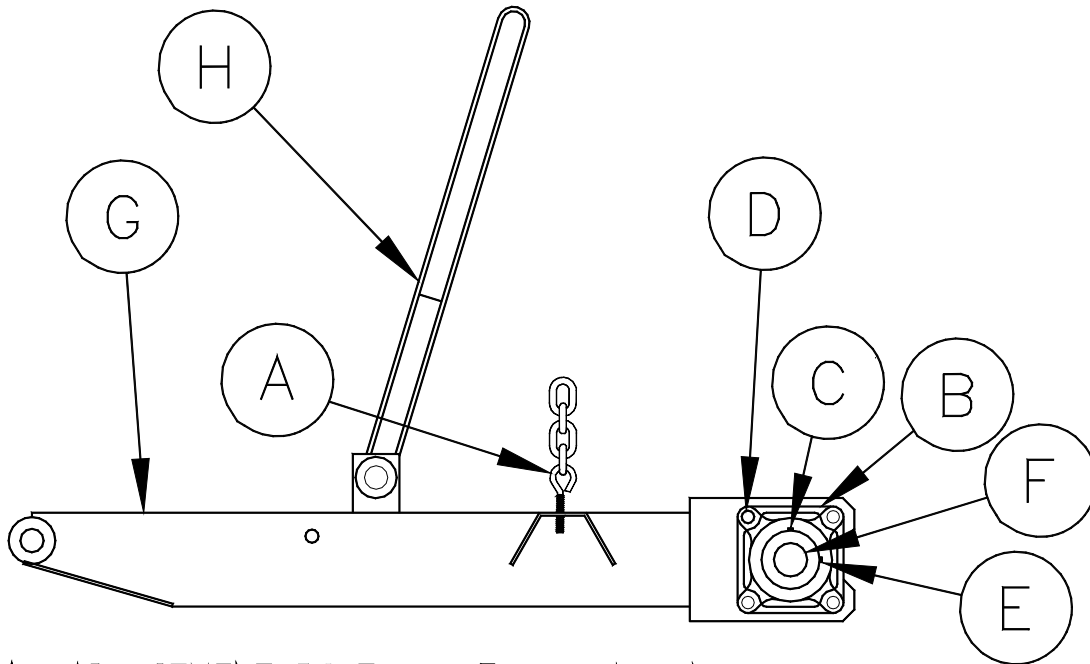

*Figure 10: Main Broom Assembly*

## Main Broom Bearing Replacement

(Refer to *Figure 11: Main Broom Arm Assembly*)

1. Lower the main broom fully to the shop floor.
2. If the bearing has an Eccentric Locking Collar, loosen the set screws (C) and tap the collar in the reverse direction of the shaft rotation, using a punch and hammer to unlock the Collar and bearing assembly (B) from the shaft (F). If the bearing does not have the Eccentric Locking Collar, loosen the set screws (C) to unlock the bearing (B) from the shaft (F).
3. Remove all 4 bolts (D) retaining bearing (B) to arm (G).
4. Clean shaft (F) with emery cloth to prevent bearing from hanging up when removing.
5. Slide bearing assembly (B) off end of broom shaft (F). A Bearing Puller may have to be used.
6. Install new bearing assembly, reversing the procedure for removal. Ensure that the bearing grease nipple (E) is pointing towards the rear of machine.
7. Centre the broom between the rear drag shoes by moving bearing (B) on the main broom shaft (F). Pull or push on main broom arm as required.
8. If bearing has an Eccentric Locking Collar, lock in place by using the Collar rotated in the direction of the shaft rotation. Tighten all set screws (C) using a thread lock. If bearing does not have Eccentric Locking Collar, tighten all set screws (C) using a thread lock.



- |                       |                          |
|-----------------------|--------------------------|
| A. ADJUSTMENT BOLT    | E. GREASE NIPPLE         |
| B. MAIN BROOM BEARING | F. MAIN BROOM SHAFT      |
| C. SET SCREW          | G. MAIN BROOM ARM        |
| D. RETAINING NUT      | H. MAIN BROOM LIFT STRAP |

*Figure 11: Main Broom Arm Assembly*

## Carbide Drag Shoe Replacement

(Refer to *Figure 12: Carbide Drag Shoe*)

1. Raise the main broom.
2. Remove bolts (B) and worn drag shoe (C).
3. Install new carbide drag shoe and bolts (B).

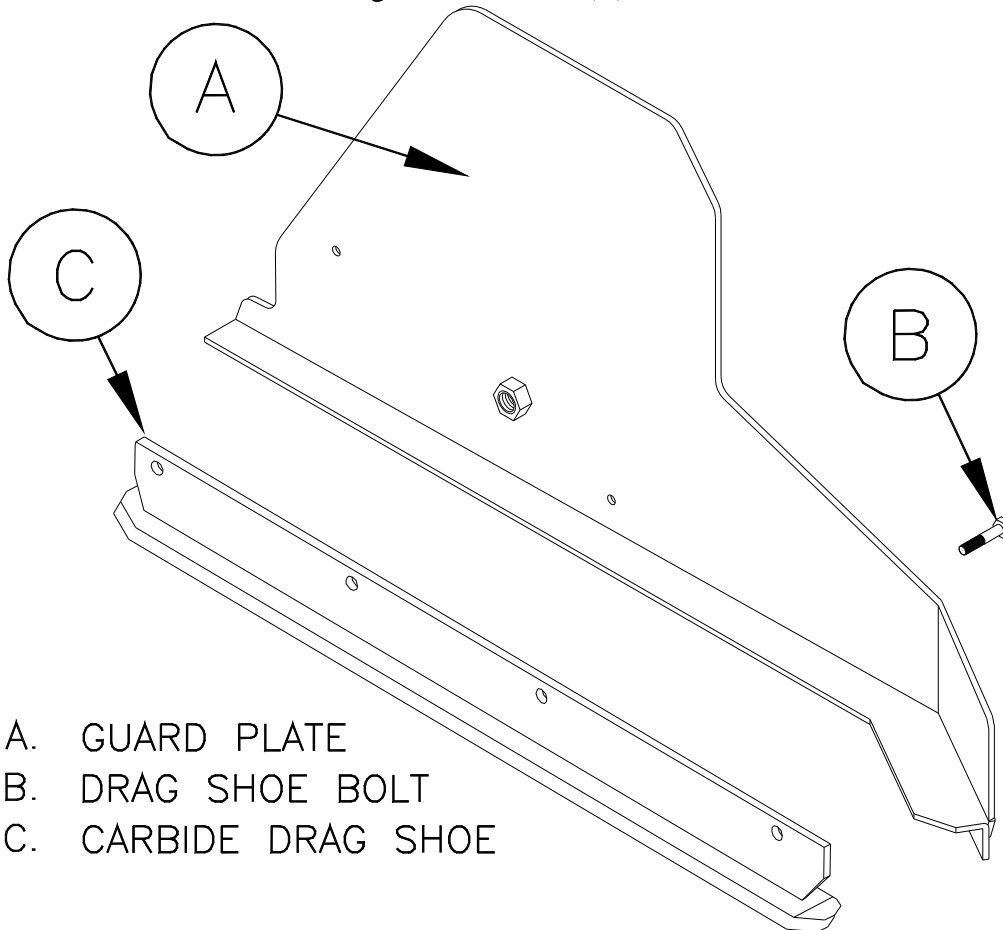

- A. GUARD PLATE
- B. DRAG SHOE BOLT
- C. CARBIDE DRAG SHOE

*Figure 12: Carbide Drag Shoe*

## Elevator Chain, Sprocket/Shaft Replacement

(Refer to *Figure 13: Elevator*)

1. Remove rear canopy.
2. Remove water tank.
3. Remove elevator canopy and canopy extension.

**NOTE:** the procedure give is for one side only and must be repeated for the opposite side.

4. Loosen top shaft bolts (C).



5. Loosen lock nut (E).
6. By adjusting bolt (D), move the top shaft slide (A) down closer to the middle of elevator housing until bearing bolts are at the bottom of the travel.
7. Loosen the bolts on bearing (H).
8. Loosen lock nut (G).
9. By adjusting bolt (F), lower bearing (H) to the bottom of the retaining bolt slots.
10. Remove squeegee (M) and squeegee angle (N) assembly from the chain.
11. Remove elevator chain master link pin and let chain fall to the floor and remove.

**NOTE:** At this point it is vary easy to replace or repair any damage to the elevator housing, shafts, sprockets, and liners if required.

**NOTE:** The elevator sprockets are split for easy removal but when installing make sure the sprockets on the same shaft are timed to each other.

**NOTE:** One of the elevator shaft retainers for each sprocket are tack welded to the shaft to maintain chain alignment, make sure one of the retainers are welded.

**NOTE:** Bottom shaft and bearings (P) should never require adjusting. This shaft is preset at the factory.

12. Install new chain (K) making sure the squeegee attachment links are aligned.
13. Adjust top shaft first using adjustment bolts (D) until proper chain tension is achieved.

**NOTE:** When adjusting top shaft make sure both sides move equally.

14. Adjust center shaft suing adjustment bolt (F) until the sprocket touches the chain.

**NOTE:** Do not add to the tension of the chain at this time. The purpose of the center shaft is to reduce chain slap when going from sweeping forward to sweeping reverse and to adjust for chain stretch as chain wears.

15. Reinstall squeegee and squeegee angles on chain.
16. Tighten all bearing slides, lock nuts, and bearing bolts.
17. Reinstall elevator canopy and canopy extension.
18. Reinstall water tank.
19. Reinstall rear canopy.

**NOTE:** The correct tension on **new** elevator chain is 1-3” deflection on the chain between shafts.

**NOTE:** Elevator chains should always be run as loose as possible, once in operation, without rubbing on each other or the separator bar.

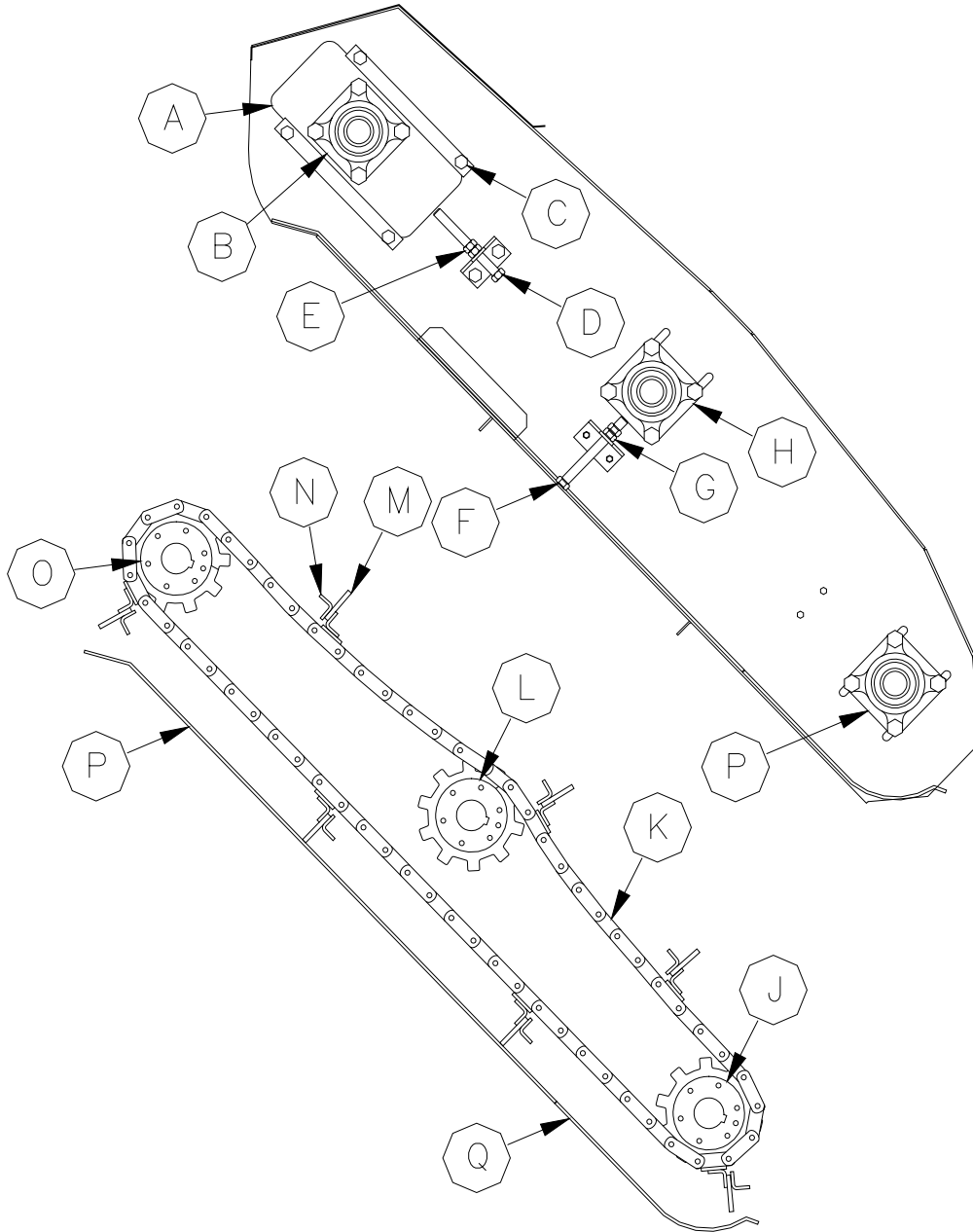

- |                         |                   |
|-------------------------|-------------------|
| A. TOP SHAFT SLIDE      | J. BOTTOM SHAFT   |
| B. TOP SHAFT BEARING    | K. ELEVATOR CHAIN |
| C. SLIDE RETAINER       | L. CENTER SHAFT   |
| D. ADJUSTMENT BOLT      | M. SQUEEGEE       |
| E. LOCK NUT             | N. SQUEEGEE ANGLE |
| F. ADJUSTMENT BOLT      | O. TOP SHAFT      |
| G. LOCK NUT             | P. TOP LINER      |
| H. CENTER SHAFT BEARING | Q. BOTTOM LINER   |
| I. BOTTOM SHAFT BEARING |                   |

*Figure 13: Elevator*



### **Bottom Liner Replacement**

1. Drive machine up on blocks ensuring machine is secure before going under machine.
2. Remove bolts that hold liner in place.
3. Remove liner.
4. Remove bottom rubber and install on new liner.
5. Reinstall liner.

### **Top Liner Replacement**

1. Remove rear canopy.
2. Remove water tank.
3. Remove elevator canopy and canopy extension.
4. Remove bolts from top liner.
5. Pull line out from the top of elevator.
6. Replace liner.
7. Reinstall elevator canopy and canopy extension.
8. Reinstall water tank.
9. Reinstall rear canopy.

### **Main Broom Hydraulic Motor Replacement**

1. Lower broom to floor.
2. Loosen bolts on main broom coupler.
3. Disconnect hydraulic lines to motor.
4. Remove motor bolts.
5. Replace motor.

**NOTE:** Motor requires an offset key in shaft, 5/16" side of key goes into the motor shaft and 1/4" goes into coupler.

6. Reinstall and tighten mounting bolts.

**NOTE:** Ensure motor shaft is completely in coupler.

7. Tighten coupler bolts.





## Gutter Broom Hydraulic Motor Replacement

1. Lower gutter broom to floor.
2. Remove one segment from the gutter broom plate.
3. From underneath remove center mount retaining bolt.
4. Remove bolts from taper lock bushing.
5. Put bolts that are removed from the bushing into the threaded holes in bushing.
6. Tighten bolts evenly until taper lock releases from shaft.
7. Gutter broom plate should slip off motor shaft.
8. Disconnect hydraulic lines to motor.
9. Remove motor mounting bolts.
10. Replace motor.
11. Reinstall and tighten motor mounting bolts.

**NOTE:** Motor requires an offset key in shaft, 5/16" side of key goes into the motor shaft and 1/4" goes into mounting plate.

12. Using a floor jack, lift gutter broom mounting plate onto shaft.
13. Tighten taper lock bushing evenly, tightening mounting plate to shaft.
14. Reinstall center mount bolts.
15. Tighten all plate and mount bolts.
16. Reinstall gutter broom segment.

## Elevator Hydraulic Motor Replacement

1. Remove drive chain mount cover.
2. Disconnect drive chain.
3. Loosen set screws on motor sprocket.
4. Remove sprocket.
5. Disconnect hydraulic lines.
6. Remove motor mounting bolts.
7. Replace motor.

**NOTE:** Motor requires an offset key in shaft, 5/16" side of key goes into the motor shaft and 1/4" goes sprocket.

8. Reinstall motor mount bolts.
9. Reinstall hydraulic lines.
10. Reinstall sprocket.
11. Connect drive chain.
12. Reinstall cover.



## Hydraulic Pressure Adjustment On Serial Numbers Up To 4011

(for RH VALVE STACK (Passengers Side))  
(set pressure to **2,850 psi @ 2 000 rpm**)

1. Install a 0-5000 psi pressure gauge in test port A on top of valve.
2. Remove cap from the relief valve.
3. Take engine to 2,000 rpm.
4. Push hopper lift switch and raise hopper until cylinders are bottomed.
5. While holding switch, read pressure gauge.
6. Turn relief screw clockwise to increase pressure and counter clockwise to lower pressure.
7. Adjust pressure to a maximum of 2,850 psi.
8. Replace relief cap and gauge.



Sweeper Co.

80120 LH VALVE  
STACK ASSEMBLY  
(DRIVERS SIDE)  
SN 7981 & UP

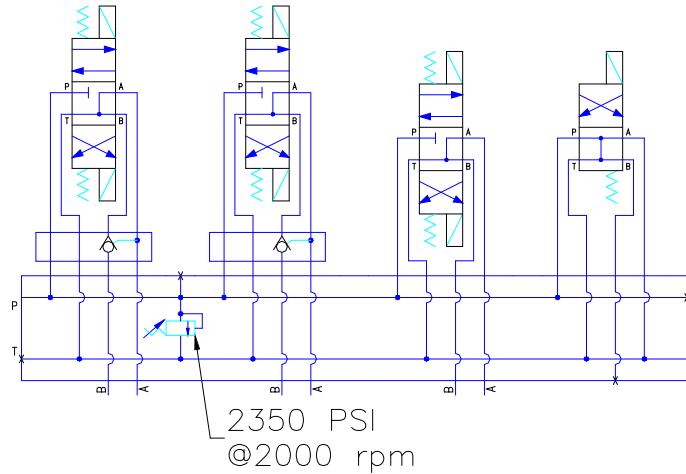

80125 RH VALVE  
STACK ASSEMBLY  
(DRIVERS SIDE)  
SN 7981 & UP

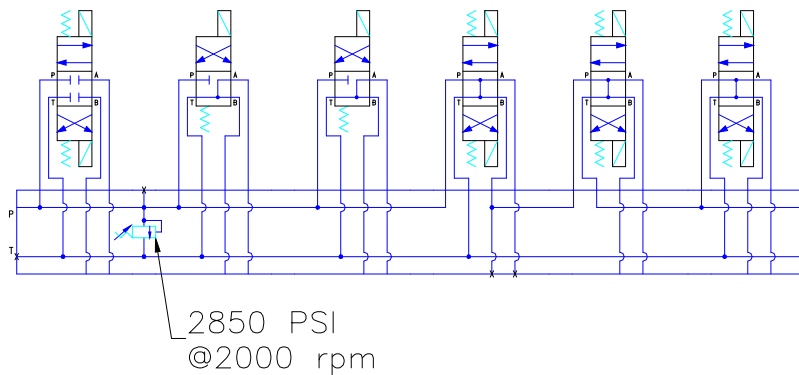

(for LH VALVE STACK (Driver Side))  
(set pressure to 2,350 psi @ 2 000 rpm)

1. Install a 0-5000 psi pressure gauge in test port A on top of valve.
2. Remove cap from the relief valve.
3. Take engine to 2,000 rpm.
4. Push hopper dump switch and dump hopper until cylinders are bottomed.
5. While holding switch, read pressure gauge.
6. Turn relief screw clockwise to increase pressure and counter clockwise to lower pressure.
7. Adjust pressure to a maximum of 2,350 psi.
8. Replace relief cap and gauge.

### Stall Switch Adjustment

1. Lift sliding ring on switch body up.
2. Push hopper dump switch on control panel and dump hopper until cylinders are bottomed.
3. With a small flat screwdriver turn inner adjustment barrel until stall alarm in cab begins to activate.
4. Turn adjustment barrel in opposite direction until stall alarm in cab is not activated.
5. Replace sliding ring on switch body.

### Electrical Activation Sequences At Valve Connectors Serial Number 4011 and Up

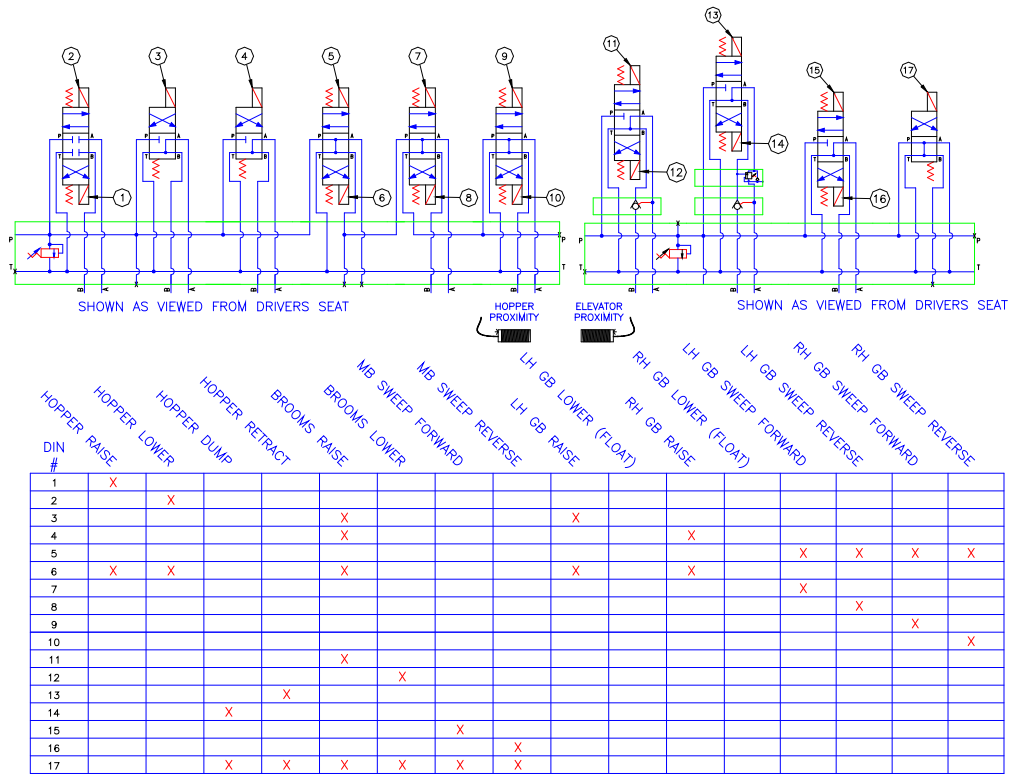



# Lubrication and Maintenance Check List



EVERY 10 HOURS

**STARFIRE SWEEPER DAILY  
MAINTENANCE CHECKLIST**

Perform this routine BEFORE every shift or after 10 hours of operation (whichever is sooner)

Sweeper S/N:                      Date:                      Hours:                      Miles:

This CHECKLIST PERFORMED BY:

		<u>Done:</u>
1	The OPERATOR has READ and THOROUGHLY UNDERSTANDS the "Safety, Operations and Maintenance Manual" for this sweeper and understands the safe operation of the vehicle including the chassis, the chassis "Owners Manual" and the diesel particulate filter. Refuel with "ULTRA LOW Sulfur Highway Diesel" ONLY.	<input type="checkbox"/>
2	Check Engine Oil (dipstick) and Coolant Levels on BOTH Engines.	<input type="checkbox"/>
3	Check Hydraulic Oil Level on the site tube on side of hydraulic oil tank.	<input type="checkbox"/>
4	Check Air Filter Restriction Indicator(AFRI) for BOTH Engines. If AFRI shows that the airflow through filter is too low, change the air filter and RESET the Indicator. Write the Date and Hours on the new filter and Note the change on this form by putting a circle around the filter changed today- TRUCK AUXILIARY	<input type="checkbox"/>
5	Check ALL tires for proper inflation and tread wear.	<input type="checkbox"/>
6	Check that Back-up Alarm, Lights, and Strobes are working properly.	<input type="checkbox"/>
7	Clean water sytem filter. Inspect water system spray nozzles. Clean, if necessary.	<input type="checkbox"/>
8	Check sweeper functions for proper operation. "Note" any exceptions.	<input type="checkbox"/>
9	Check broom sweeping pattern of side and main brooms. Correct any bad pattern.	<input type="checkbox"/>
10	Service truck chassis - refer to Owners Manual.	<input type="checkbox"/>
11	Check power steering, transmission, and windshield washer fluids.	<input type="checkbox"/>
12	Inspect for any damage and any loose items such as wires, fittings, pins, nuts and bolts. Correct problem and/or NOTE below.	<input type="checkbox"/>



**NOTES and REMARKS:**

---



---



---

Perform this routine AFTER every shift or after 10 hours of operation (whichever is sooner)

Sweeper S/N:                      Date:                      Hours:                      Miles:

**This CHECKLIST PERFORMED BY:**

		<u>Done:</u>
1	Allow BOTH engines to idle for 2 minutes before shut-down.	<input type="checkbox"/>
2	WASH THOROUGHLY: Including engine radiators, hydraulic oil cooler, elevator (including the shafts), hopper and hopper lift frame/scissors area. Be sure engine is cool before washing. DO NOT use high pressure to wash radiators or hydraulic oil cooler fins.	<input type="checkbox"/>
3	Grease elevator shaft bearings and main broom stub-shaft bearing with EP2 grease.  Note: the shafts should be rotating while being greased to insure proper distribution of lubricant.	<input type="checkbox"/>
4	Check for and remove any tape, string, etc., wound around broom motor shafts.	<input type="checkbox"/>
5	Inspect for any damage and any loose items such as wires, fittings, pins, nuts and bolts. Correct problem and/or NOTE below.	<input type="checkbox"/>

**NOTES and REMARKS:**

---



---



---

**Thank you for choosing Stewart-Amos Sweepers! HAPPY SWEEPING!!!**



EVERY 40 HOURS

**STARFIRE SWEEPER WEEKLY  
MAINTENANCE CHECKLIST**

Perform this routine WEEKLY or after 40 hours of operation (whichever is sooner)

Sweeper S/N: \_\_\_\_\_ Date: \_\_\_\_\_ Hours: \_\_\_\_\_ Miles: \_\_\_\_\_

This CHECKLIST PERFORMED BY: \_\_\_\_\_

		<u>Done:</u>
<b>1</b>	The OPERATOR has READ and THOROUGHLY UNDERSTANDS the "Safety, Operations and Maintenance Manual" for this sweeper and understands the safe operation of the vehicle including the chassis, the chassis "Owners Manual" and the diesel particulate filter. Refuel with "ULTRA LOW Sulfur Highway Diesel" ONLY.	<input type="checkbox"/>
<b>2</b>	Perform the DAILY ROUTINE.	<input type="checkbox"/>
<b>3</b>	Grease the pivot point on the main broom and gutter broom "arms".	<input type="checkbox"/>
<b>4</b>	Perform an extra thorough cleaning of the hydraulic oil cooler.	<input type="checkbox"/>
<b>5</b>	Service truck chassis - refer to Owners Manual.	<input type="checkbox"/>
<b>6</b>	Inspect for any damage and any loose items such as wires, fittings, pins, nuts and bolts. Correct problem and/or NOTE below.	<input type="checkbox"/>

**NOTES and REMARKS:**

---



---



---



---

Thank you for choosing Stewart-Amos Sweepers! HAPPY SWEEPING!!!





**EVERY 250 HOURS**

**STARFIRE SWEEPER PERIODIC  
MAINTENANCE CHECKLIST**

**ALL MAINTENANCE BEYOND DAILY AND  
WEEKLY IS PERFORMED ON A USAGE BASIS AS  
INDICATED IN THE MANUALS**

Perform this routine **AFTER EVERY 250 hours of operation OR sooner if conditions dictate**

Sweeper S/N:	Date:	Hours:	Miles:
<b>This CHECKLIST PERFORMED BY:</b>			
			<u>Done:</u>
<b>1</b>	<b>Change BOTH engine oils AND filters - Write Date and Hours on filter housings.</b>		<input type="checkbox"/>
<b>2</b>	<b>Replace hydraulic oil filter - Write Date and Hours on filter housing.</b>		<input type="checkbox"/>
<b>3</b>	<b>Clean hydraulic oil tank breather filter.</b>		<input type="checkbox"/>
<b>4</b>	<b>Inspect for any damage and any loose items such as wires, fittings, pins, nuts and bolts. Correct problem and/or NOTE below.</b>		<input type="checkbox"/>

**NOTES and REMARKS:**

---



---



---



---

**Thank you for choosing Stewart-Amos Sweepers! HAPPY SWEEPING!!!**



EVERY 1000 HOURS

**STARFIRE SWEEPER PERIODIC  
MAINTENANCE CHECKLIST**

ALL MAINTENANCE BEYOND DAILY AND WEEKLY IS PERFORMED ON A USAGE BASIS AS INDICATED IN THE MANUALS

Perform this routine AFTER EVERY 1000 hours of operation OR sooner if conditions dictate

<b>Sweeper S/N:</b>	<b>Date:</b>	<b>Hours:</b>	<b>Miles:</b>
<b>This CHECKLIST PERFORMED BY:</b>			

		<u>Done:</u>
1	Perform a 250 hour Maintenance Routine.	<input type="checkbox"/>
2	Change Hydraulic Oil per Manual.	<input type="checkbox"/>
3	Grease chassis per "Owners Manual" including front steering linkage, U-joints, bearings, and king pins.	<input type="checkbox"/>
4	Check elevator chain for adjustment.	<input type="checkbox"/>
5	Inspect for any damage and any loose items such as wires, fittings, pins, nuts and bolts. Correct problem and/or NOTE below.	<input type="checkbox"/>

**NOTES and REMARKS:**

---



---



---



---

Thank you for choosing Stewart-Amos Sweepers! HAPPY SWEEPING!!!

## S-4 SERVICE POINTS

### DRIVERS SIDE SERVICE POINTS

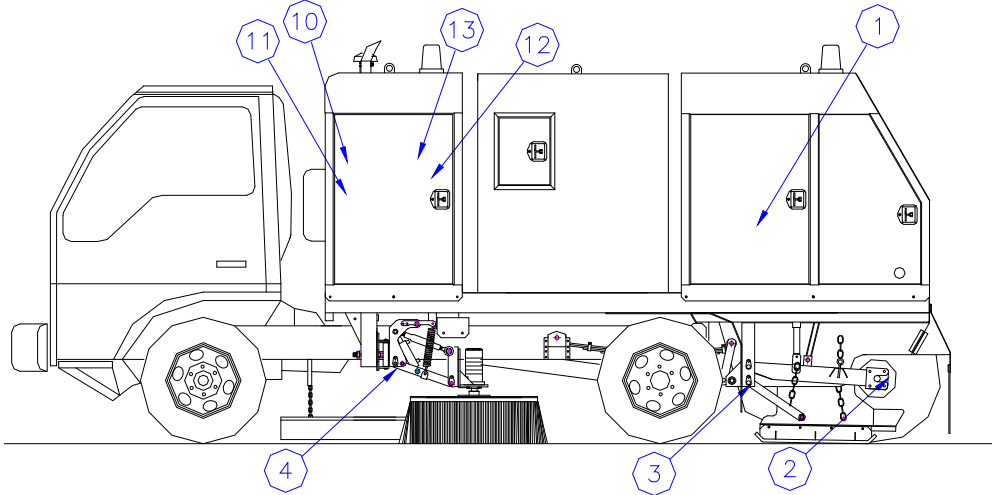

### SWEEPER SERVICE POINTS

LOCATION	NO. OF POINTS	FREQUENCY	DESCRIPTION
1	3	DAILY	ELEVATOR BEARINGS (DRIVERS SIDE)
2	1	DAILY	MAIN BROOM BEARING
3	3	DAILY	MB AND DRAG SHOE LINKAGE
4	3	WEEKLY	GUTTER BROOM LINKAGE
5	3	DAILY	ELEVATOR BEARINGS (PASSENGER SIDE)
6	3	DAILY	MB AND DRAG SHOE LINKAGE
7	3	WEEKLY	GUTTER BROOM LINKAGE
8	1	DAILY	ENGINE OIL LEVEL
9	1	DAILY	HYDRAULIC OIL LEVEL
10	1	DAILY	AIR FILTER
11	1	AS REQ.	FUEL FILTER
12	1	250 HR.	HYDRAULIC OIL FILTER
13	1	1000 HRS.	HYDRAULIC OIL
14	1	250 HRS	ENGINE OIL
15	1	250 HRS	ENGINE OIL FILTER

### PASSENGER SIDE SERVICE POINTS

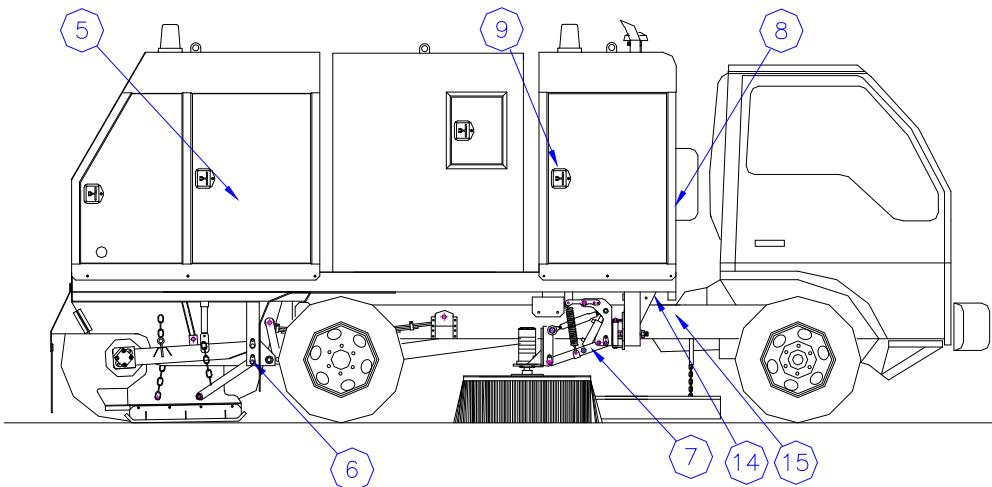



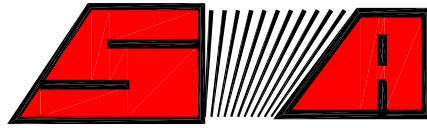

**STEWART-AMOS**

**Sweeper Co.**

STARFIRE

S-4

PARTS MANUAL

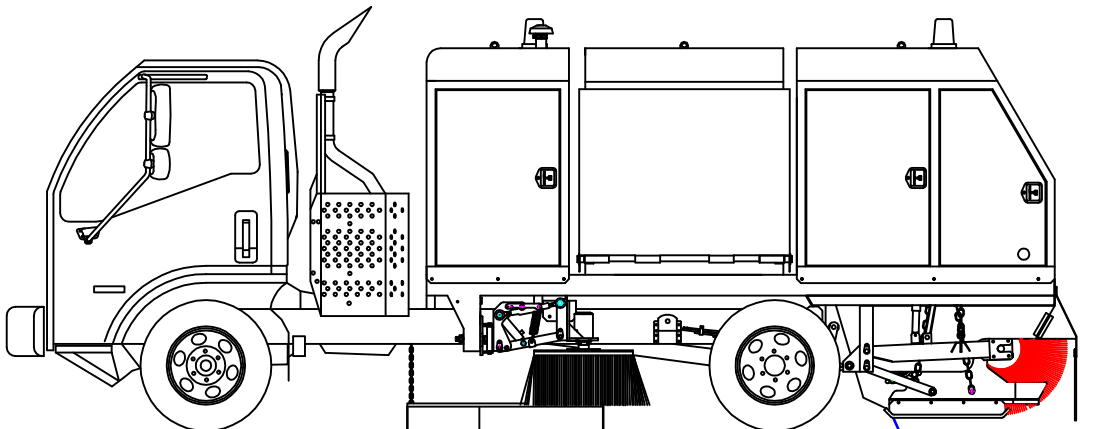

SN 4011 and UP  
Last Updated February 6, 2012



# TABLE OF CONTENTS

MAIN FRAME	89
FRONT CANOPY	91
REAR CANOPY	93
HOPPER	95
LIFT FRAME SCISSOR	97
GUTTER BROOM	99
MAIN BROOM	103
HYDRAULICS	107
AUXILARY ENGINE	117
ELEVATOR	121
WATER SYSTEM	129
ELECTRICAL	131
IN CAB PANEL	142
DECALS	143
INDEX	153

# MAIN FRAME ASSEMBLY SN 4011 & UP

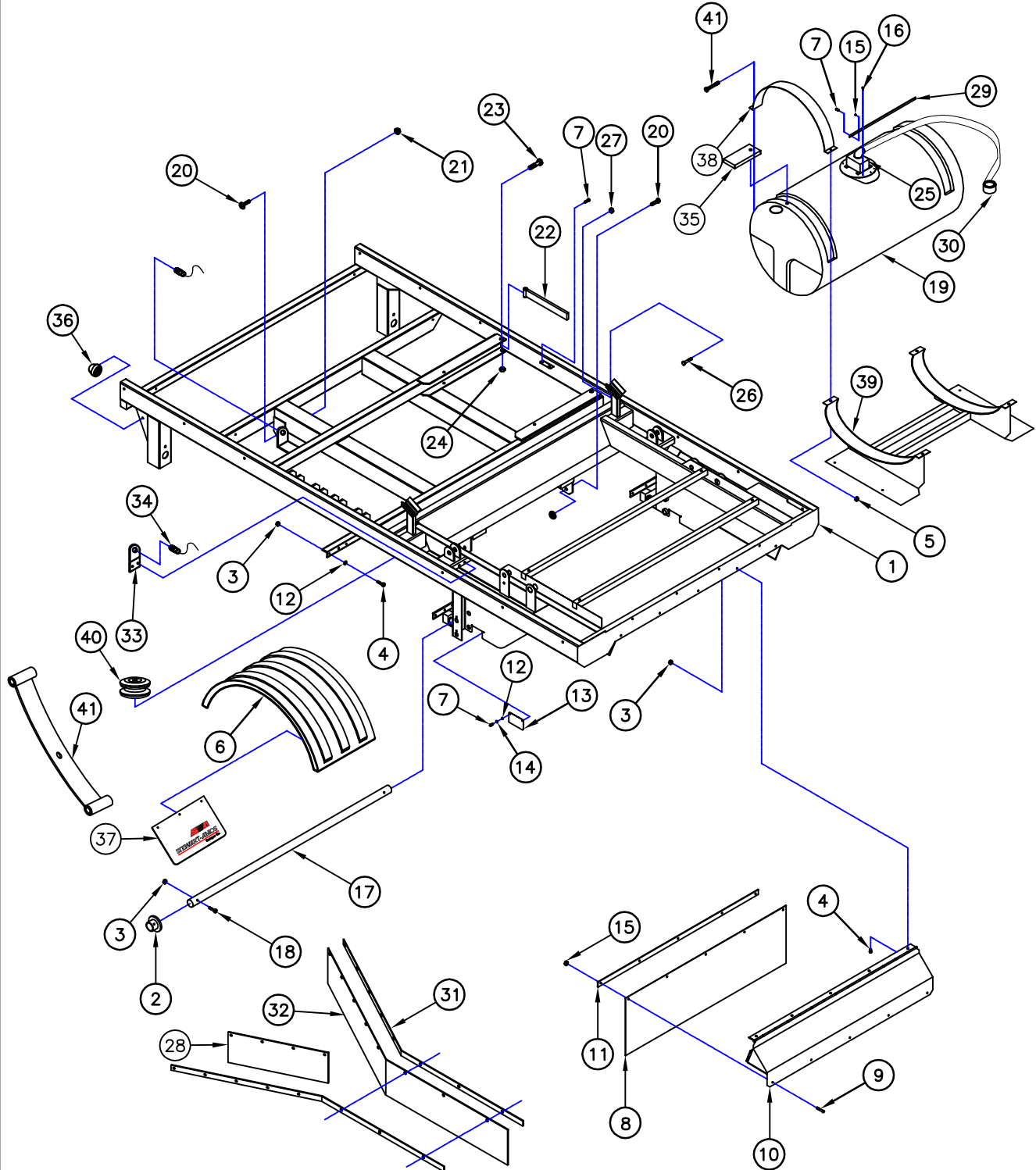



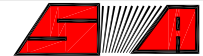

**STEWART-AMOS**

Sweeper Co

MAIN FRAME  
ASSEMBLY  
SN 4011 & UP

ITEM	PART #	DESCRIPTION	QTY
1	42001-B	MAIN FRAME WELDMENT	1
2	43129	ELEVATOR CENTERING BUSHING	2
3	1502	NUT	17
4	1535	BOLT	17
5	1505	NUT	4
6	1143	FENDER	2
7	1537	BOLT	2
8	42073	SKIRT	1
9	1534	BOLT	12
10	42060	REAR SKIRT	1
11	42075	BASE STRIP	1
12	1822	WASHER	16
13	42077	BEARING INSPECTION COVER	2
14	1670	WASHER	4
15	1503	NUT	12
16	1591	SCREW	6
17	41771	REST TUBE	1
18	1843	BOLT	2
19	1075	200 GAL. PLASTIC WATER TANK	1
20	1730	BOLT	4
21	1740	NUT	4
22	42085	SAFETY PROP	2
23	1573	BOLT	2
24	1507	NUT	2
25	42065	WATER VALVE	1
26	1546	BOLT	2
27	1640	NUT	2
28	42147	CENTER DRAG RUBBER	1
29	42083	WATER VALVE ROD	1
30	1116	HYDRANT HOSE	1
31	42103	CENTER DRAG SUPPORT	2
32	42101	CENTER DRAG RUBBER	1
33	42507	PROXIMITY MOUNT	1
34	1087-3	PROXIMITY SWITCH	2
35	42214	FILL RELIEF RUBBER	1
36	1026	WORK LIGHT	2
37	42121	MUD FLAP	2
38	42220-06	WATER TANK STRAP	2
39	42220	WATER TANK MOUNT	1
40	1125	TIMBREN	1
41	1200	ISUZU LEAF SPRING	2

# FRONT CANOPY ASSEMBLY SN 4011 & UP

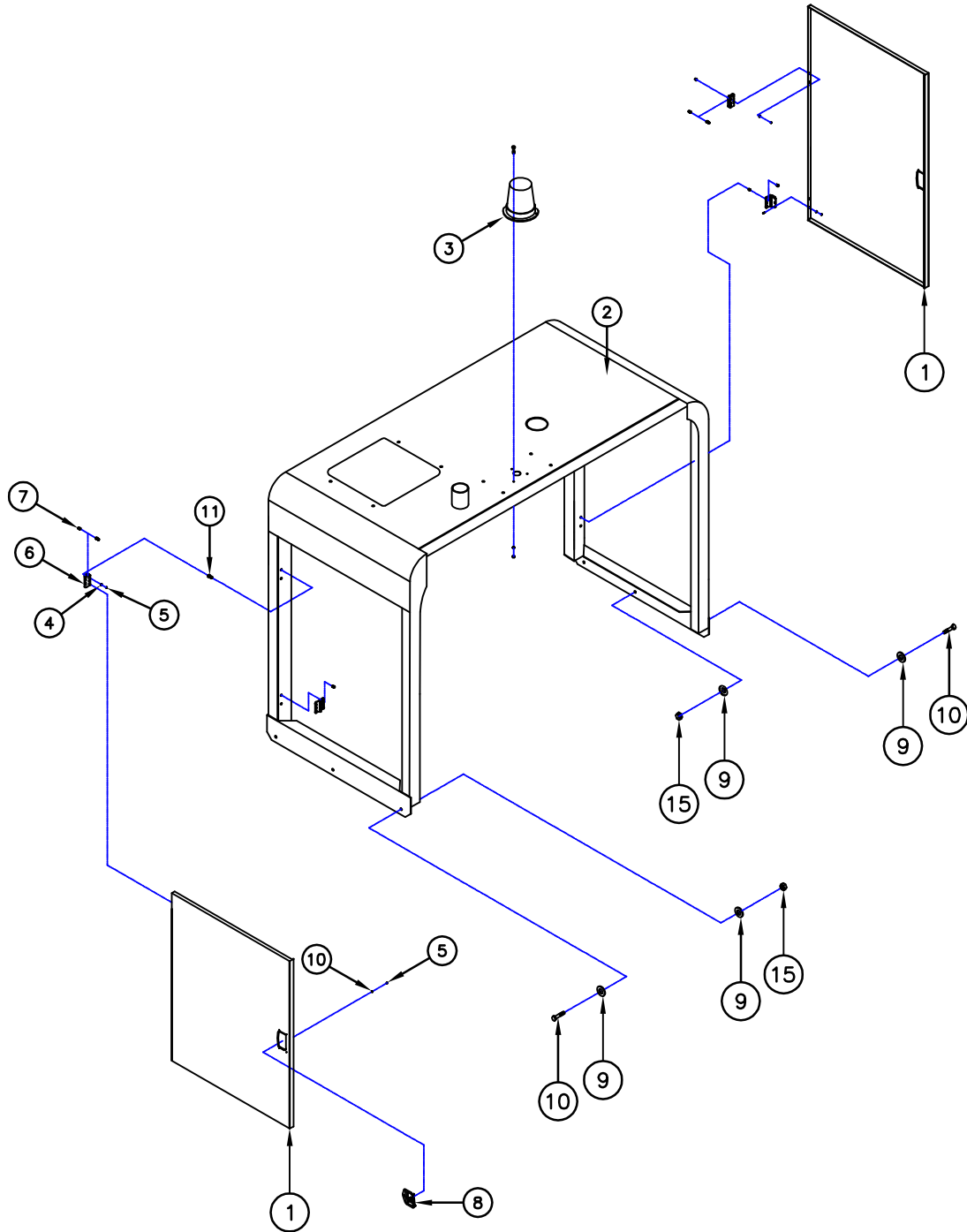

FRONT CANOPY  
ASSEMBLY  
SN 4011 & UP

ITEM	PART #	DESCRIPTION	QTY
1	41503	DOOR	2
2	41501	FRONT CANOPY	1
3	1916	STROBE	1
4	1520	WASHER	20
5	1501	NUT	20
6	1031	HINGE	4
7	1579	BOLT	8
8	1005	DOOR LATCH	4
9	1522	WASHER	6
10	1843	BOLT	6
11	1750	INSERT	8
12	1559	BOLT	4
13	1521	WASHER	17
14	1502	NUT	8
15	1503	NUT	6
	42107	LIMB GUARD (NOT SHOWN OPTIONAL)	1

# REAR CANOPY ASSEMBLY SN 4011 & UP

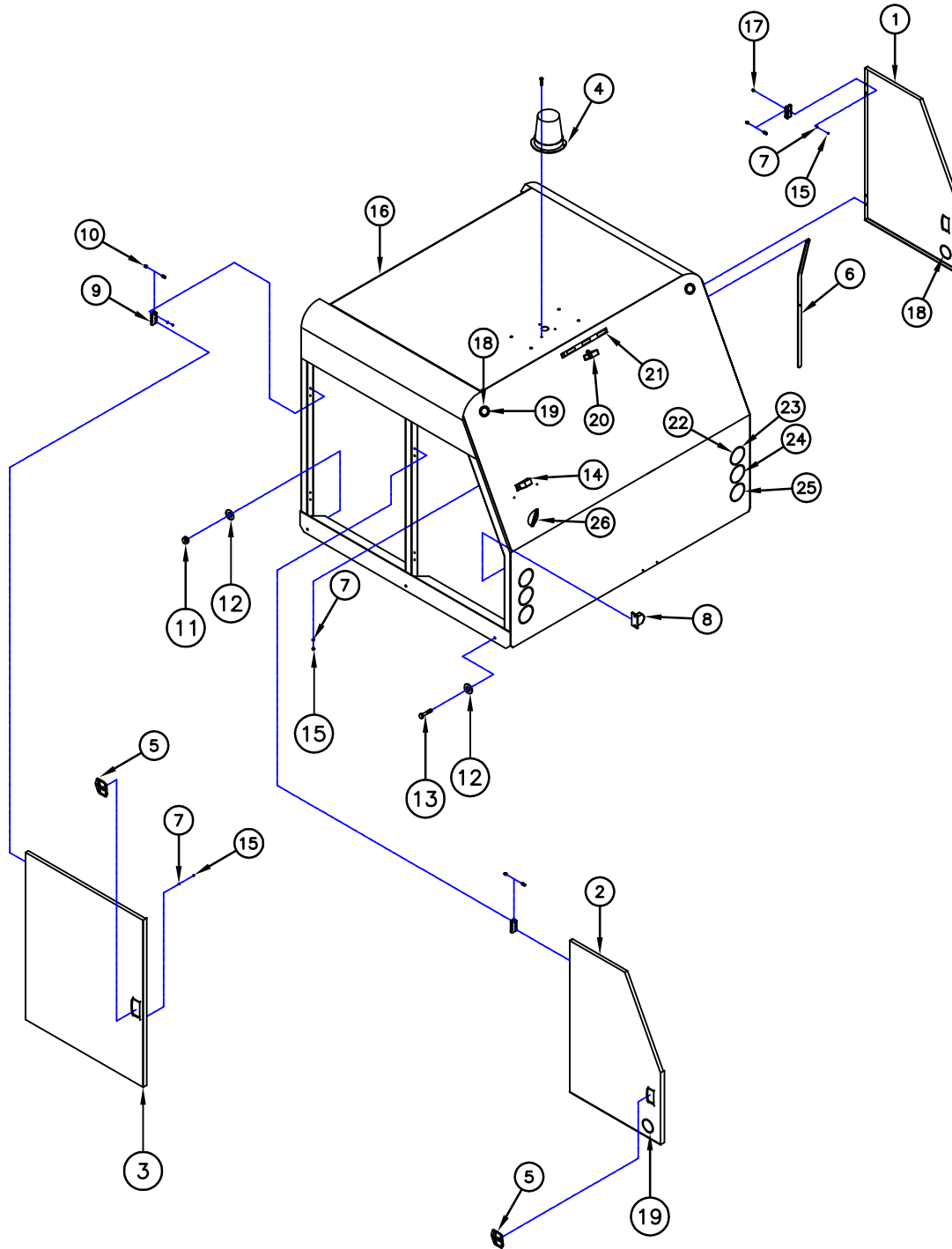



**STEWART-AMOS**

Sweeper Co

REAR CANOPY  
ASSEMBLY  
SN 4011 & UP

ITEM	PART #	DESCRIPTION	QTY
1	41614	RIGHT REAR DOOR	1
2	41612	LEFT REAR DOOR	1
3	41503	DOOR	2
4	1916	STROBE	1
5	1005	DOOR LATCH	4
6	42081	WATER VALVE LEVER	1
7	1520	WASHER	36
8	1024	BACKUP ALARM	1
9	1031	HINGE	8
10	1579	BOLT	32
11	1503	NUT	6
12	1822	WASHER	6
13	1843	BOLT	6
14	1908	LICENSE PLATE LIGHT	1
15	1501	NUT	36
16	41602	REAR CANOPY	1
17	1750	INSERT	16
18	1905	CLEARANCE LIGHT	4
19	1906	GROMMET	4
20	1152	CAMERA	1
21	1907	ID BAR	1
22	1911	BACKUP LIGHT	2
23	1912	GROMMET	6
24	1910	TURN SIGNAL LIGHT	2
25	1909	BRAKE LIGHT	2
26	1915	WORK LIGHT	1
	42107	LIMB GUARD <sub>(NOT SHOWN)</sub>	1

# HOPPER ASSEMBLY

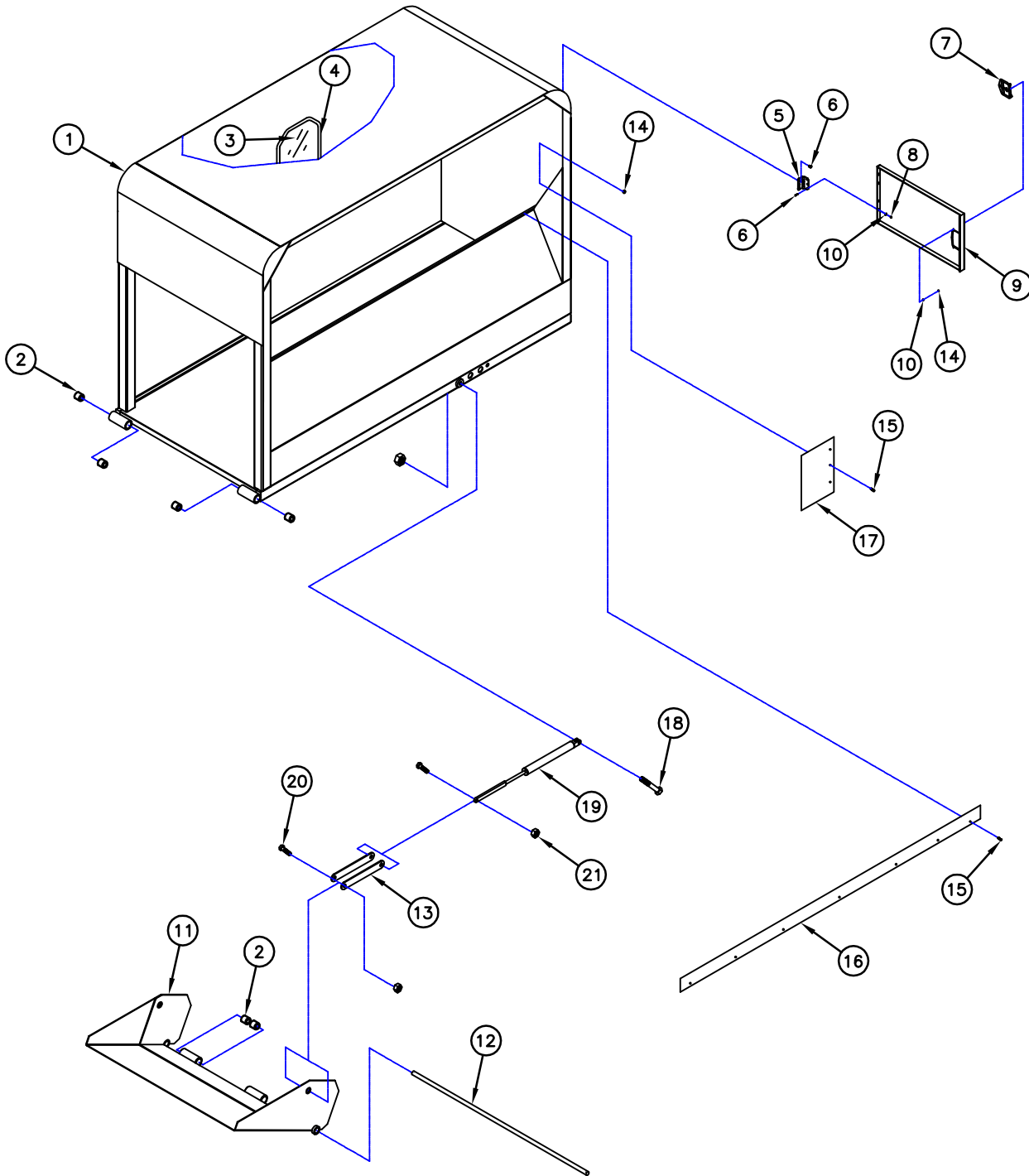

## HOPPER ASSEMBLY

ITEM	PART #	DESCRIPTION	QTY
1	42901	HOPPER	1
2	1185	BUSHING	8
3	1033	WINDOW RUBBER	37"
4	42913	WINDOW	1
5	1031	HINGE	2
6	1579	BOLT	8
7	1005	DOOR LATCH	1
8	1501	NUT	8
9	62907	ACCESS DOOR	1
10	1520	WASHER	20
11	42907	HOPPER DOOR	1
12	42909	PIN	1
13	42905	DOOR LINK	4
14	1503	NUT	20
15	1530	BOLT	20
16	42915	RUBBER FLASHING	2
17	42917	UPRIGHT FLASHING	1
18	1560	BOLT	2
19	1061	CYLINDER	2
20	1558	BOLT	4
21	1583	NUT	4

# LIFT FRAME SCISSOR ASSEMBLY SN 4011 & UP

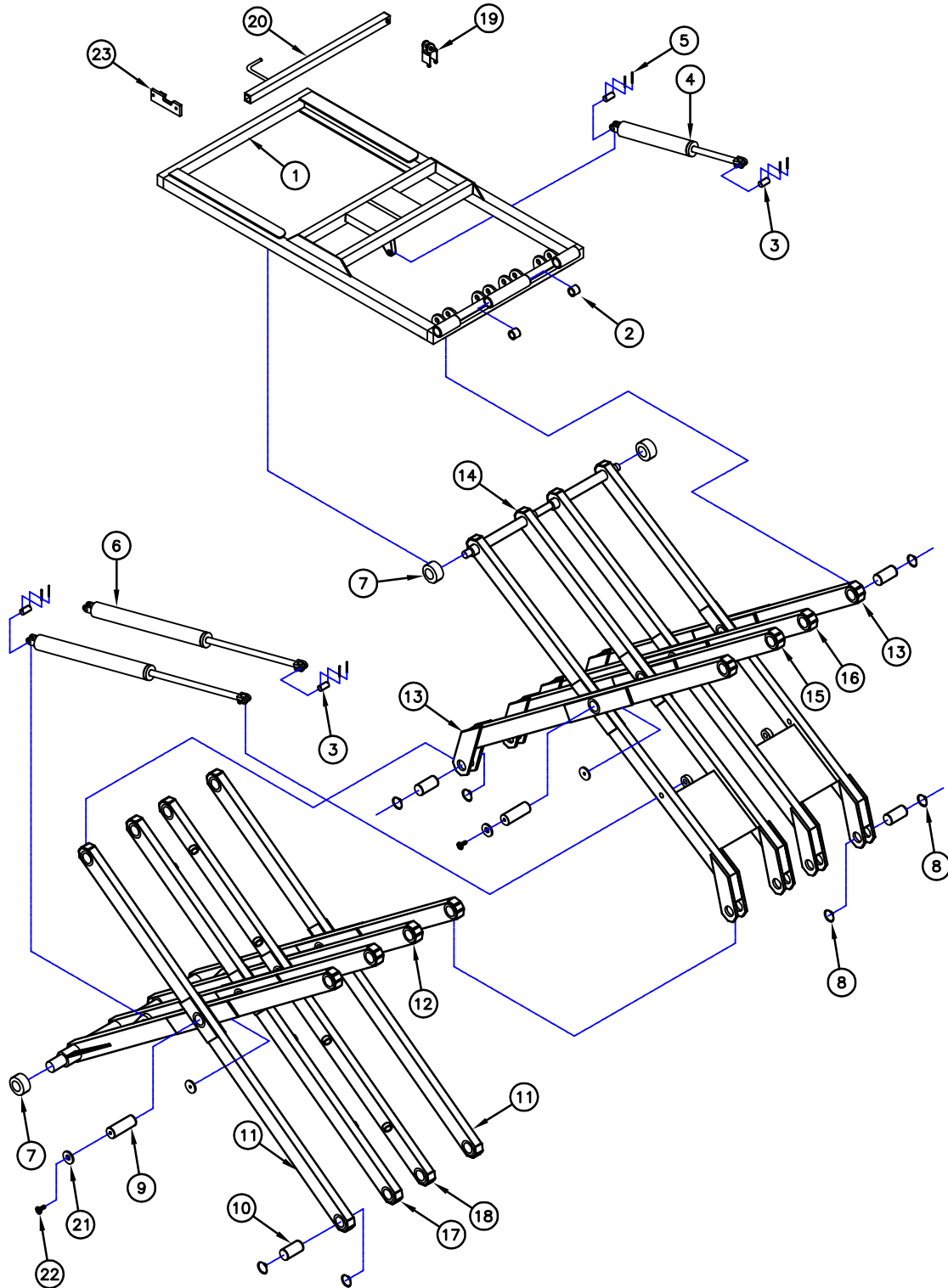



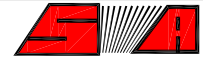

**STEWART-AMOS**

Sweeper Co

LIFT FRAME  
SCISSOR  
ASSEMBLY  
SN 4011 & UP

ITEM	PART #	DESCRIPTION	QTY
1	43001	HOPPER LIFT FRAME	1
2	1185	BUSHING	6
3	1621	PIN	6
4	1060	CYLINDER	1
5	1604	COTTER PIN	12
6	1059	CYLINDER	2
7	42813	SCISSOR ROLLER	4
8	1074	SNAP RING	16
9	62812	CENTER PIN	8
10	42809	SCISSOR PIN	16
11	42803	LOWER SCISSOR, ANCHOR SECTION	2
12	42801	LOWER SCISSOR, ROLLER SECTION	1
13	42807	UPPER SCISSOR, ANCHOR SECTION	2
14	42805	UPPER SCISSOR, ROLLER SECTION	1
15	42819	UPPER SCISSOR, ANCHOR SECTION	1
16	42821	UPPER SCISSOR, ANCHOR SECTION	1
17	42815	LOWER SCISSOR, ANCHOR SECTION	1
18	42817	LOWER SCISSOR, ANCHOR SECTION	1
19	42130	SAFETY MOUNT	1
20	42131	SAFETY	1
21	62813	RETAINER WASHER	16
22	1782	BOLT	16
23	42132	HOPPER SAFETY MOUNT	1

# GUTTER BROOM ASSEMBLY UPPER SECTION

(QUANTITIES SHOWN ARE FOR ONE SIDE ONLY)

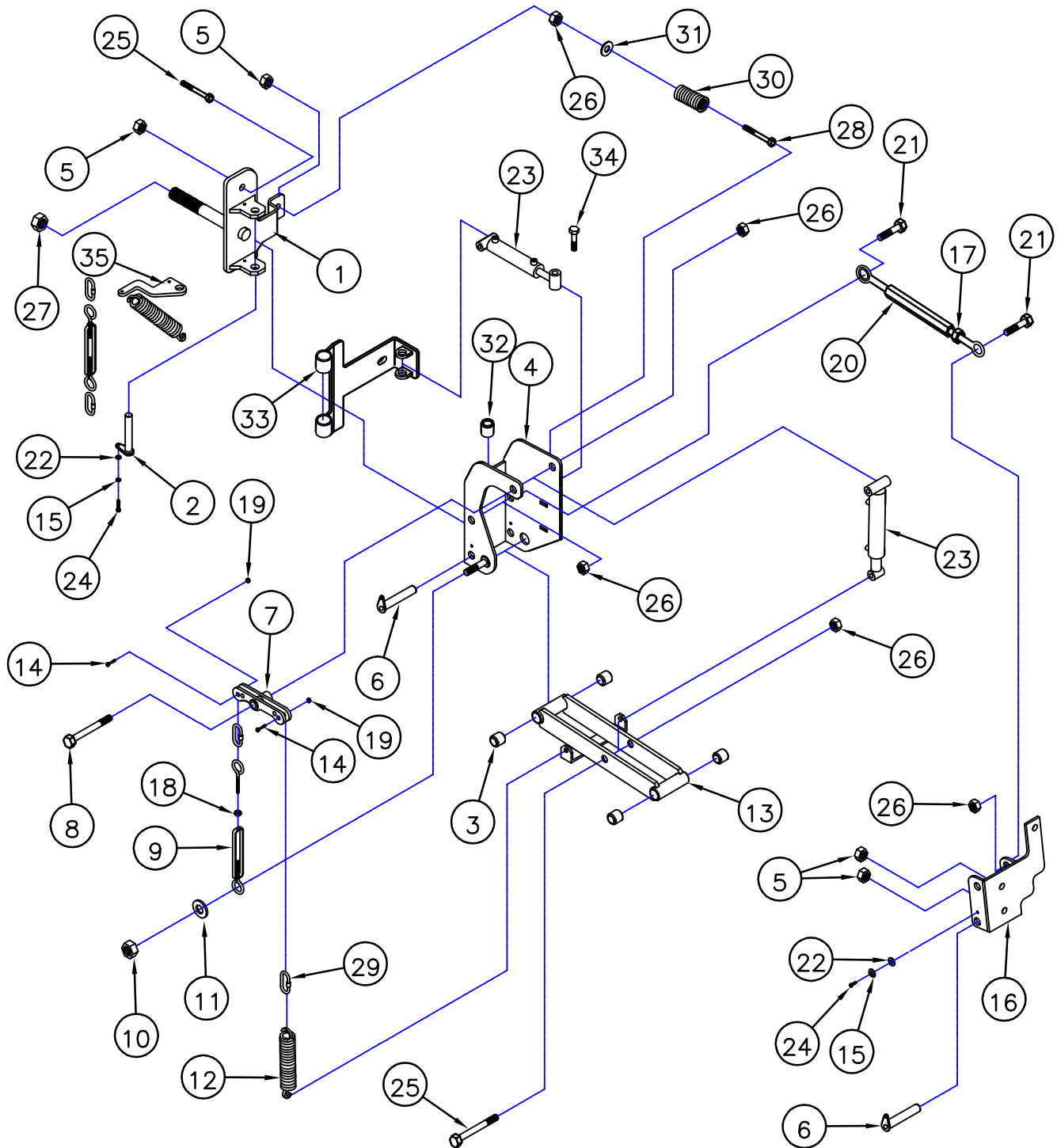



**STEWART-AMOS**

Sweeper Co

# GUTTER BROOM ASSEMBLY UPPER SECTION

(QUANTITIES SHOWN ARE FOR ONE SIDE ONLY)

ITEM	PART #	DESCRIPTION	QTY
1	61201	GB MOUNT (LEFT HAND)	1
	61301	GB MOUNT (RIGHT HAND)	1
2	61213	PIN	1
3	1020	BUSHING	4
4	61203	GB PIVOT (LEFT)	1
	61303	GB PIVOT (RIGHT)	1
5	1506	NUT	5
6	41211	PIN	2
7	41215	SPRING BELL CRANK	1
8	1561	BOLT	1
9	1023	TURN BUCKLE	1
10	1505	NUT	1
11	1581	WASHER	1
12	1018	SUSPENSION SPRING	1
13	41221	LINK	1
14	1540	BOLT	2
15	1670	WASHER	3
16	41205	LINKAGE MOUNT (LEFT)	1
	41316	LINKAGE MOUNT (RIGHT)	1
17	1642	NUT	2
18	1640	NUT	1
19	1503	NUT	2
20	1022	TURN BUCKLE	2
21	1559	BOLT	5
22	1822	WASHERS	3
23	1379	CYLINDER	2
24	1537	BOLT	3
25	1556	BOLT	2
26	1507	NUT	7
27	1508	NUT	1
28	1574	BOLT	1
29	1042	QUICK LINK	2
30	1019	RETRACT SPRING	1
31	1526	WASHER	2
32	1185	BUSHING	4
33	61235	RETRACT PLATE (LEFT)	1
	61335	RETRACT PLATE (RIGHT)	1
34	1560	BOLT	2
35	41230	EXTEND SPRING MOUNT	1

# GUTTER BROOM ASSEMBLY LOWER SECTION

(QUANTITIES SHOWN ARE FOR ONE SIDE ONLY)

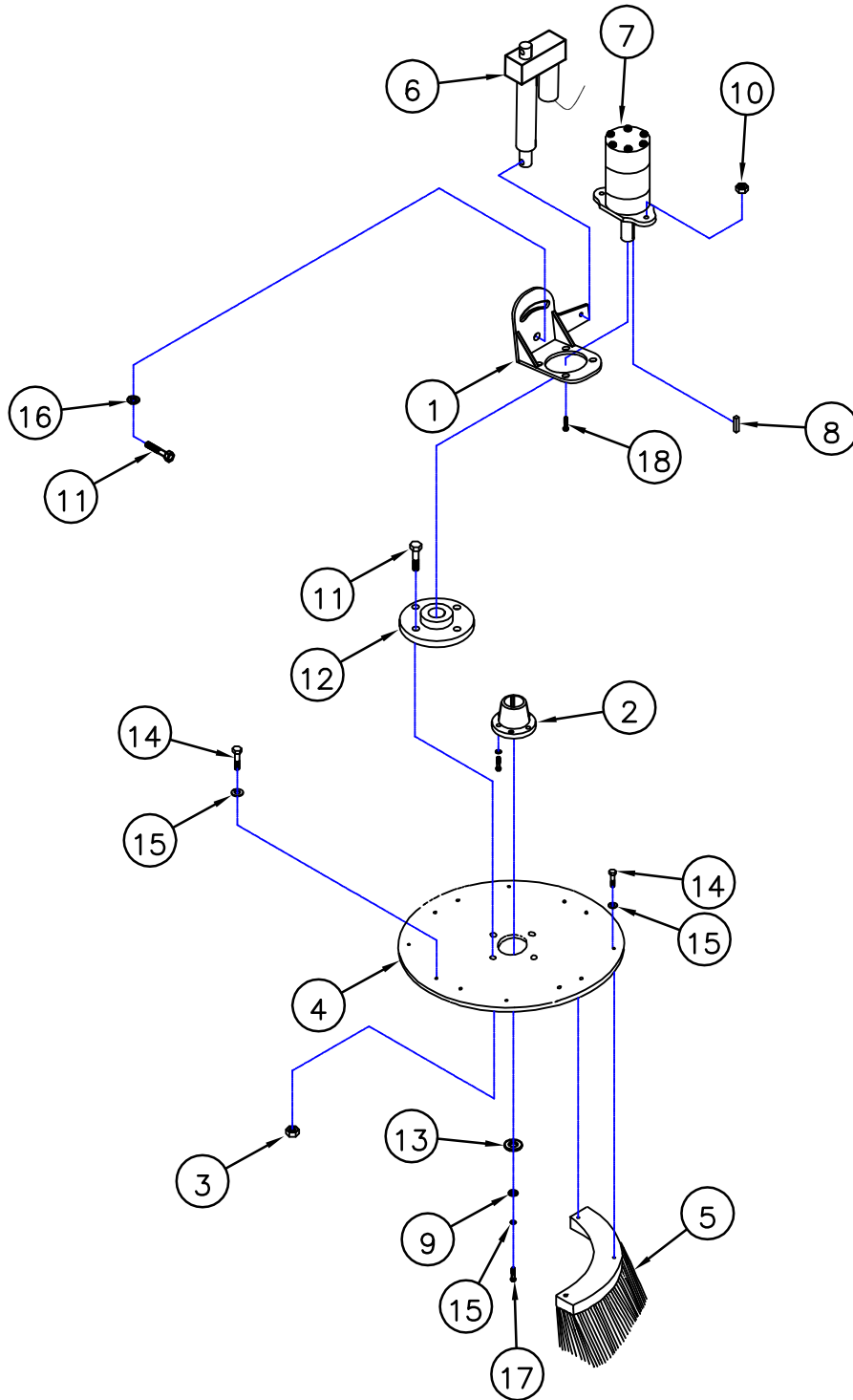

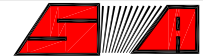

**STEWART-AMOS**

Sweeper Co

# GUTTER BROOM ASSEMBLY LOWER SECTION

(QUANTITIES SHOWN ARE FOR ONE SIDE ONLY)

ITEM	PART #	DESCRIPTION	QTY
1	41207	MOTOR BRACKET (LEFT)	1
	41318	MOTOR BRACKET (RIGHT)	1
2	1010	BUSHING C/W 3-BOLT, 3-LW	1
3	1506	NUT	4
4	41227	32" PLATE	1
5	1148	GB BRUSH SET FOR 32" PLATE	1
6	1078	LINEAR ACTUATOR	1
7	3230	MOTOR	1
8	1145	OFFSET KEY	1
9	1822	WASHERS	1
10	1505	NUT	2
11	1549	BOLT	4
12	41209	DRIVE HUB	1
13	1526	WASHER	1
14	1540	BOLT	24
15	1670	WASHER	5
16	1525	WASHER	2
17	1537	BOLT	3
18	1546	BOLT	2

# MAIN BROOM ASSEMBLY

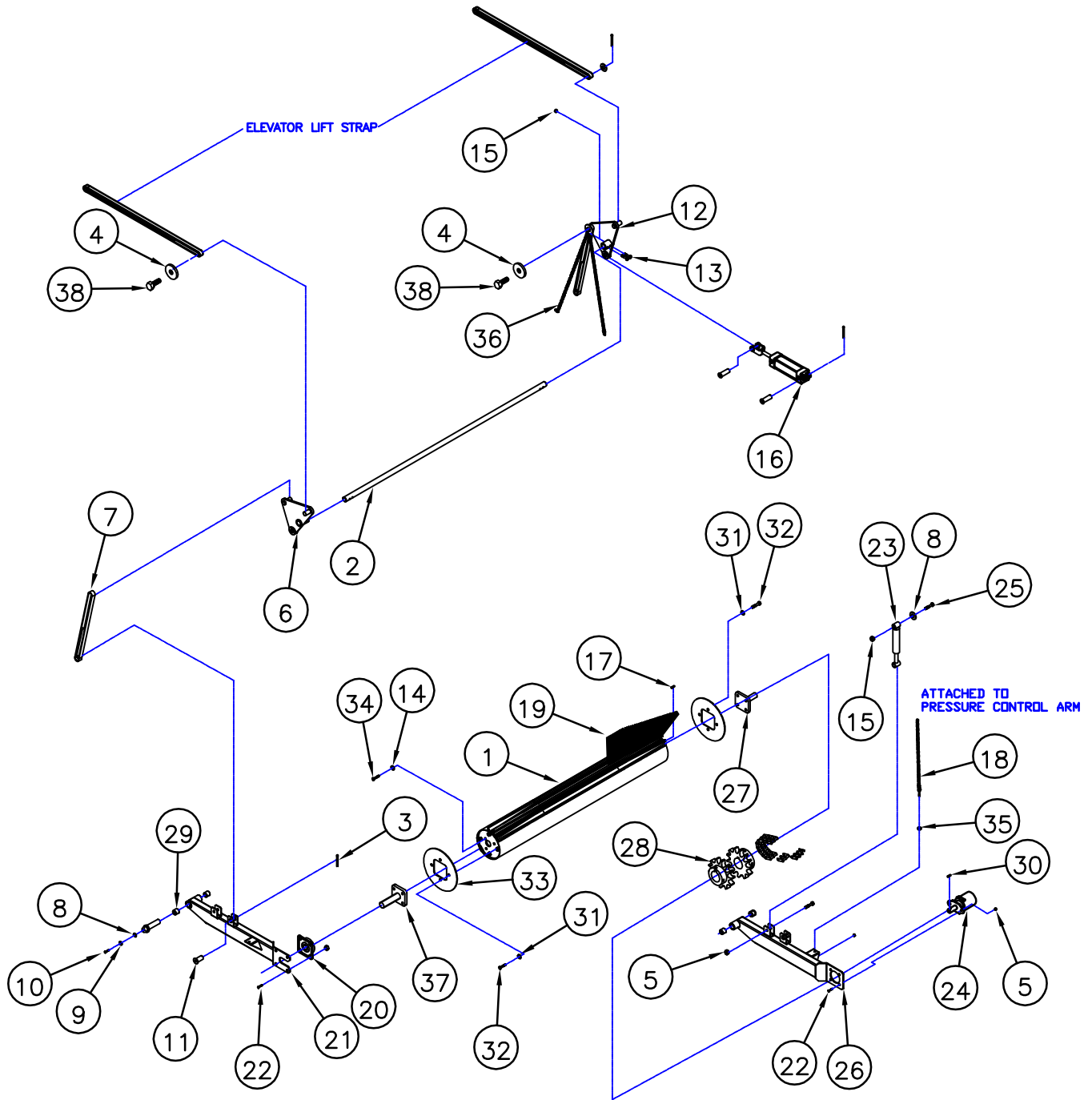

# MAIN BROOM ASSEMBLY



ITEM	PART #	DESCRIPTION	QTY
1	1014	MAIN BROOM MANDREL	1
2	41413	MAIN BROOM ROCK SHAFT	1
3	1604	COTTER PIN	2
4	62813	WASHER	4
5	1505	NUT	6
6	41405	LIFT BELL CRANK (LEFT)	1
7	41421	MAIN BROOM LIFT STRAP	2
8	1822	WASHER	30
9	1670	WASHER	2
10	1537	BOLT	2
11	41417	PIN	2
12	41407	LIFT BELL CRANK (RIGHT)	1
13	1630	CAPSCREW	4
14	1671	WASHER	6
15	1503	NUT	10
16	1043	CYLINDER	2
17	1680	KEY	1
18	41427	MAIN BROOM LIFT CHAIN	2
19	1016	MAIN BROOM STRIP SET	1
20	1030	BEARING	1
21	61401	MB LIFT ARM (LEFT)	1
22	1546	BOLT	6
23	1046	SHOCK	2
24	3230	HYDRAULIC MOTOR	1
25	1843	BOLT	4
26	41411	MAIN BROOM LIFT ARM (RIGHT)	1
27	3213-4	MANDRELL SHAFT	1
28	80126	MAIN BROOM COUPLER	1
29	1185	BUSHING	4
30	1145	OFFSET KEY	1
31	1669	WASHER	6
32	1781	BOLT	6
33	1266	MANDRELL END PLATE	2
34	1545	BOLT	6
35	1639	NUT	2
36	41437	DRAG SHOE LIFT CHAIN	2
37	3212	LONG MANDRELL SHAFT	1
38	1782	BOLT	4

# MAIN BROOM ASSEMBLY

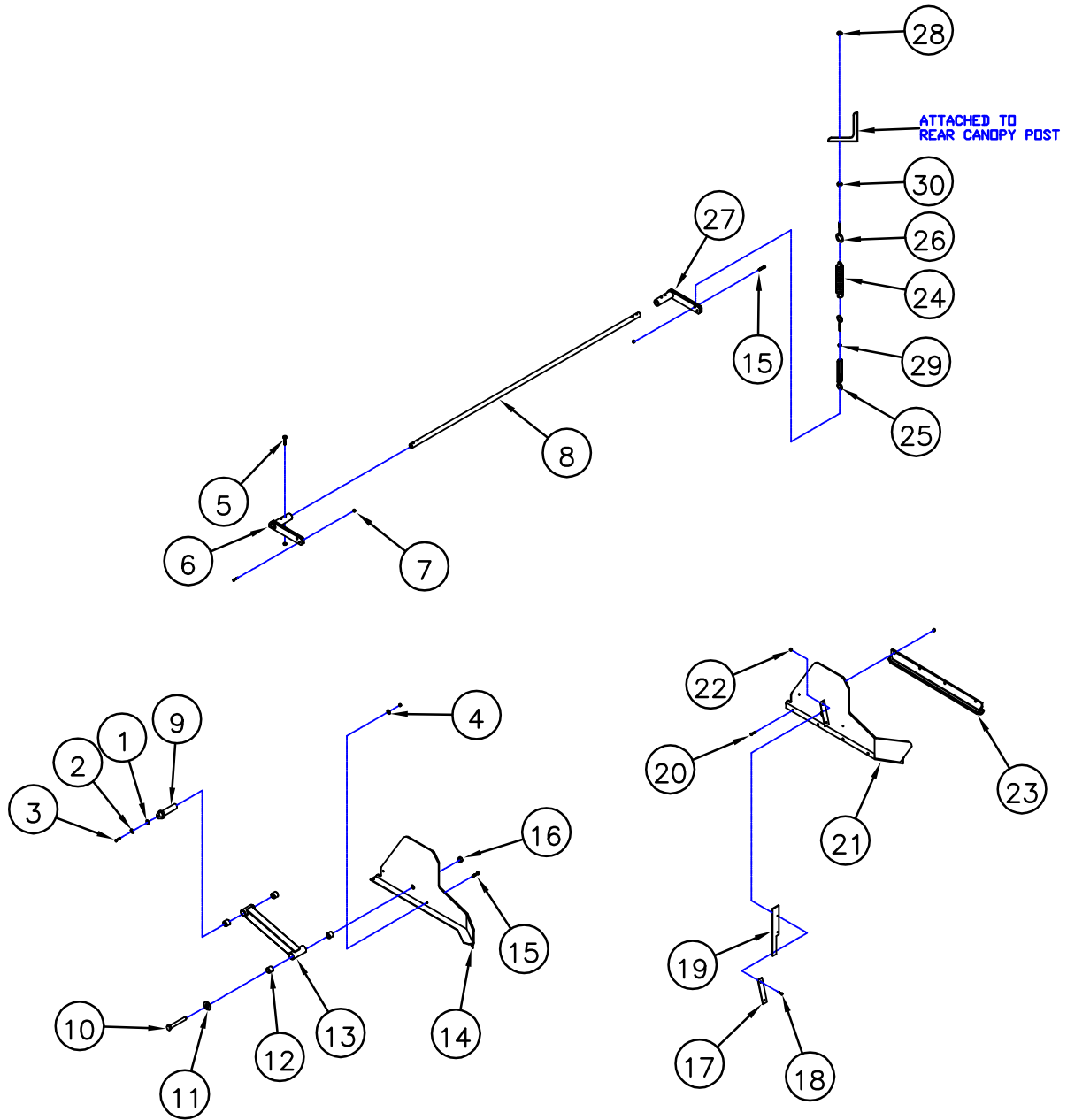



## MAIN BROOM ASSEMBLY

ITEM	PART #	DESCRIPTION	QTY
1	1822	WASHER	2
2	1670	WASHER	2
3	1537	BOLT	2
4	1521	WASHER	4
5	1630	CAPSCREW	4
6	41423	PRES. CONTROL ARM (LEFT)	1
7	1502	NUT	8
8	41415	PRES. CONTROL ROCK SHAFT	1
9	41401	PIN	4
10	1562	BOLT	2
11	1527	WASHER	2
12	1185	BUSHING	8
13	41429	DRAG LINK	2
14	41433	DRAG SHOE MOUNT (LEFT)	1
15	1534	BOLT	6
16	1508	NUT	2
17	41431	BACKING	2
18	1530	BOLT	4
19	42067	DIRT DEFLECTOR RUBBER	2
20	1575	BOLT	8
21	41435	DRAG SHOE MOUNT (RIGHT)	1
22	1501	NUT	4
23	1115	CARBIDE DRAG SHOE	2
24	1018	SUSPENSION SPRING	2
25	1023	TURN BUCKLE	2
26	1045	EYE BOLT	2
27	41425	PRES. CONTROL ARM (RIGHT)	1
28	1503	NUT	10
29	1640	NUT	2
30	1639	NUT	2

# LH VALVE SPOOL ASSEMBLY (DRIVERS SIDE) SN 4011 & UP

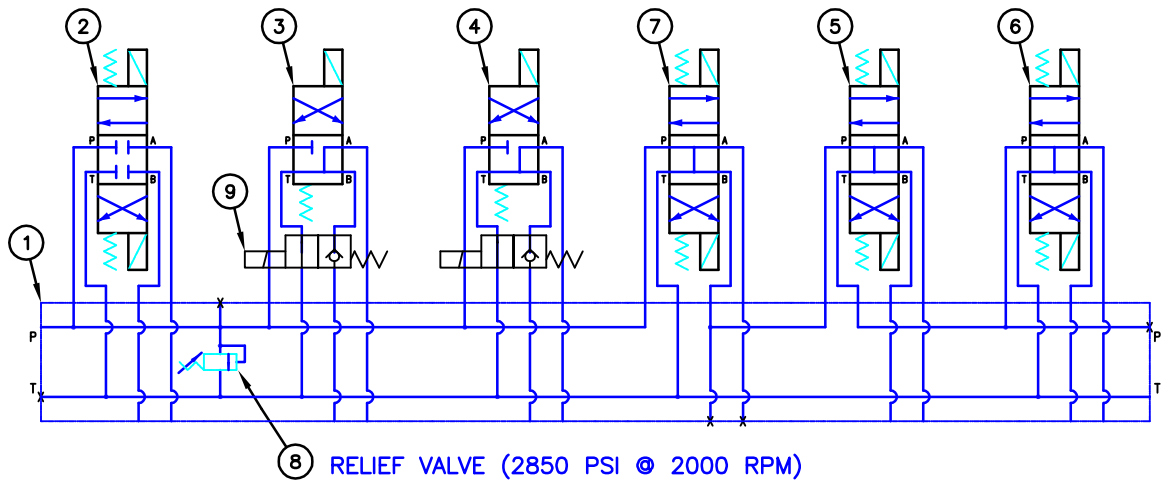

SHOWN AS VIEWED FROM DRIVERS SEAT

ITEM	PART #	DESCRIPTION	QTY
1	1293	MANIFOLD	1
2	2001	HOPPER LIFT CYLINDER VALVE	1
3	1989	LH GUTTER BROOM LIFT CYLINDER VALVE	1
4	1989	RH GUTTER BROOM CYLINDER VALVE	1
5	1295	LH GUTTER BROOM MOTOR VALVE	1
6	1295	RH GUTTER BROOM MOTOR VALVE	1
7	1295	DUMP VALVE	1
8	2000	RELIEF VALVE (2850 PSI @ 2000 RPM)	1
9	1990	FLOAT VALVE	2



**STEWART-AMOS**

Sweeper Co

# RH VALVE SPOOL ASSEMBLY (PASSENGERS SIDE) SN 4011 & UP

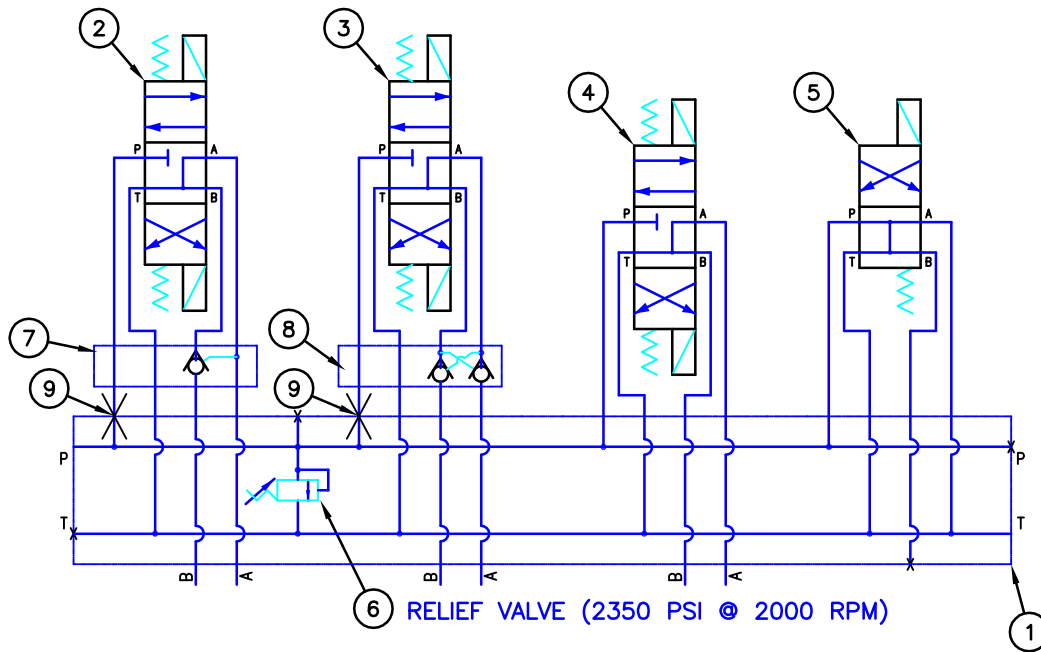

SHOWN AS VIEWED FROM DRIVERS SEAT

ITEM	PART #	DESCRIPTION	QTY
1	1287	MANIFOLD	1
2	1993	MAIN BROOM/ELEVATOR LIFT CYLINDER VALVE	1
3	1993	HOPPER TILT/DOOR CYLINDER VALVE	1
4	1993	MAIN BROOM/ELEVATOR MOTOR VALVE	1
5	1291	DUMP VALVE	1
6	2000	RELIEF VALVE (2350 PSI @ 2000 RPM)	1
7	1994	P.O. CHECK VALVE	1
8	2010	DOUBLE P.O. CHECK VALVE	1
9	1839	1/16" RESTRICTOR	2

# DRIVERS SIDE HYDRAULIC HOSE SCHEMATIC SN 4011 & UP

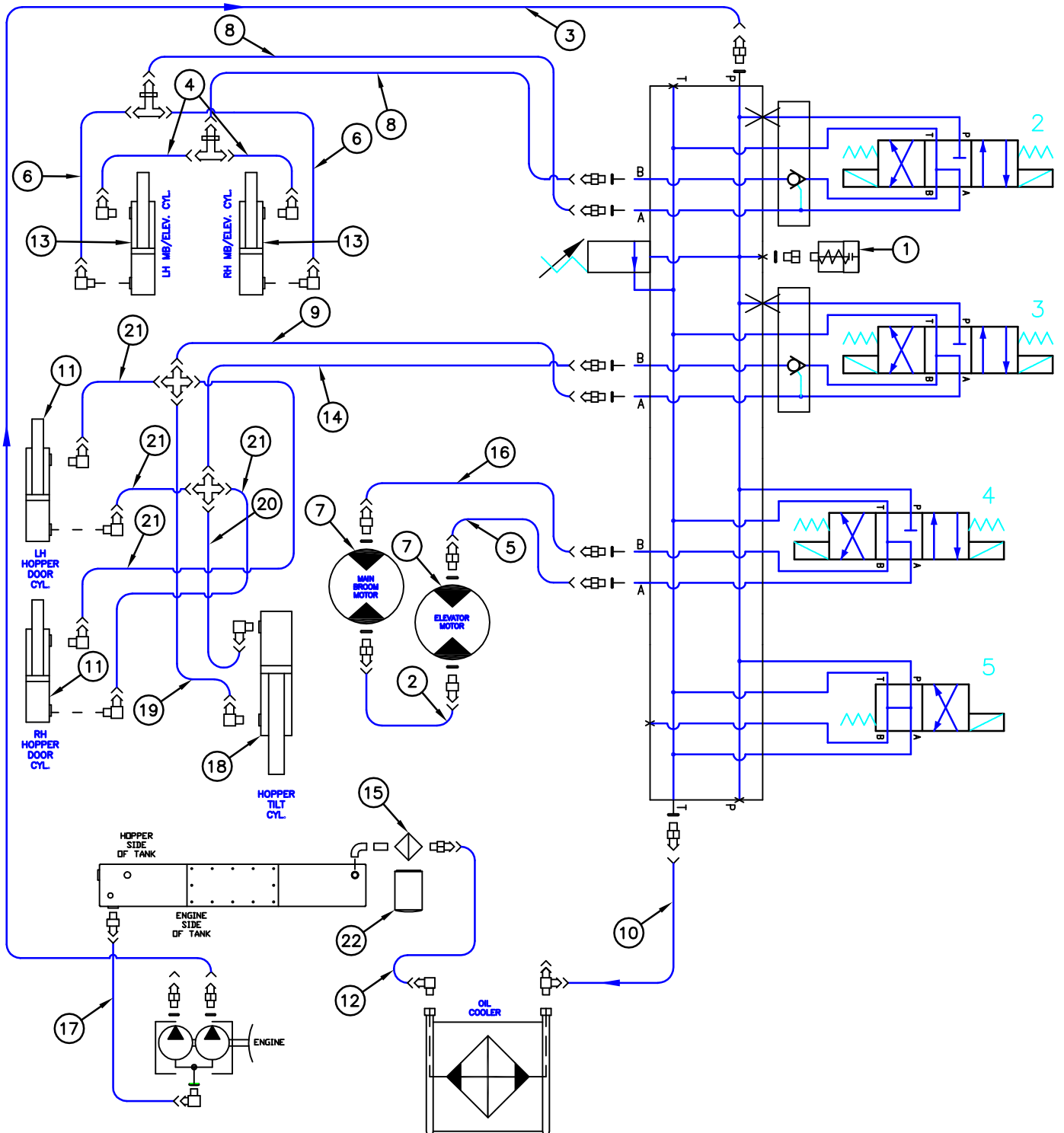

DRIVERS SIDE  
HYDRAULIC HOSE  
SCHEMATIC  
SN 4011 & UP



ITEM	PART #	DESCRIPTION	QTY
1	1037	ELEVATOR STALL SWITCH	1
2	1401	HOSE-MB MOTOR TO ELEV. MOTOR	1
3	1402	HOSE-FRONT OF PUMP TO LH VALVE	1
4	1403	HOSE-MB ROD TO "T"	2
5	1404	HOSE-ELEV. MOTOR TO VALVE	1
6	1405	HOSE-MB HEAD TO "T"	2
7	3230	HYDRAULIC MOTOR	2
8	1406	HOSE-MB VALVE TO "T"	2
9	1407	HOSE-HOPPER TILT VALVE TO CROSS	1
10	1408	HOSE-VALVE RETURN TO COOLER "T"	1
11	1061	HOPPER DOOR CYLINDER	2
12	1409	HOSE-COOLER TO FILTER	1
13	1043	MB CYLINDER	2
14	1410	HOSE-HOPPER TILT VALVE TO CROSS	1
15	1411	HYDRAULIC OIL FILTER BASE	1
16	1417	HOSE-MB MOTOR TO VALVE	1
17	1412	HOSE-SUCTION	1
18	1060	HOPPER TILT CYLINDER	1
19	1413	HOSE-HOPPER TILT ROD TO CROSS	1
20	1414	HOSE-HOPPER TILT HEAD TO CROSS	1
21	1415	HOSE-HOPPER DOOR CYLINDERS	4
22	1416	HYDRAULIC OIL FILTER	1

# DRIVERS SIDE HYDRAULIC FITTING SCHEMATIC SN 4011 & UP

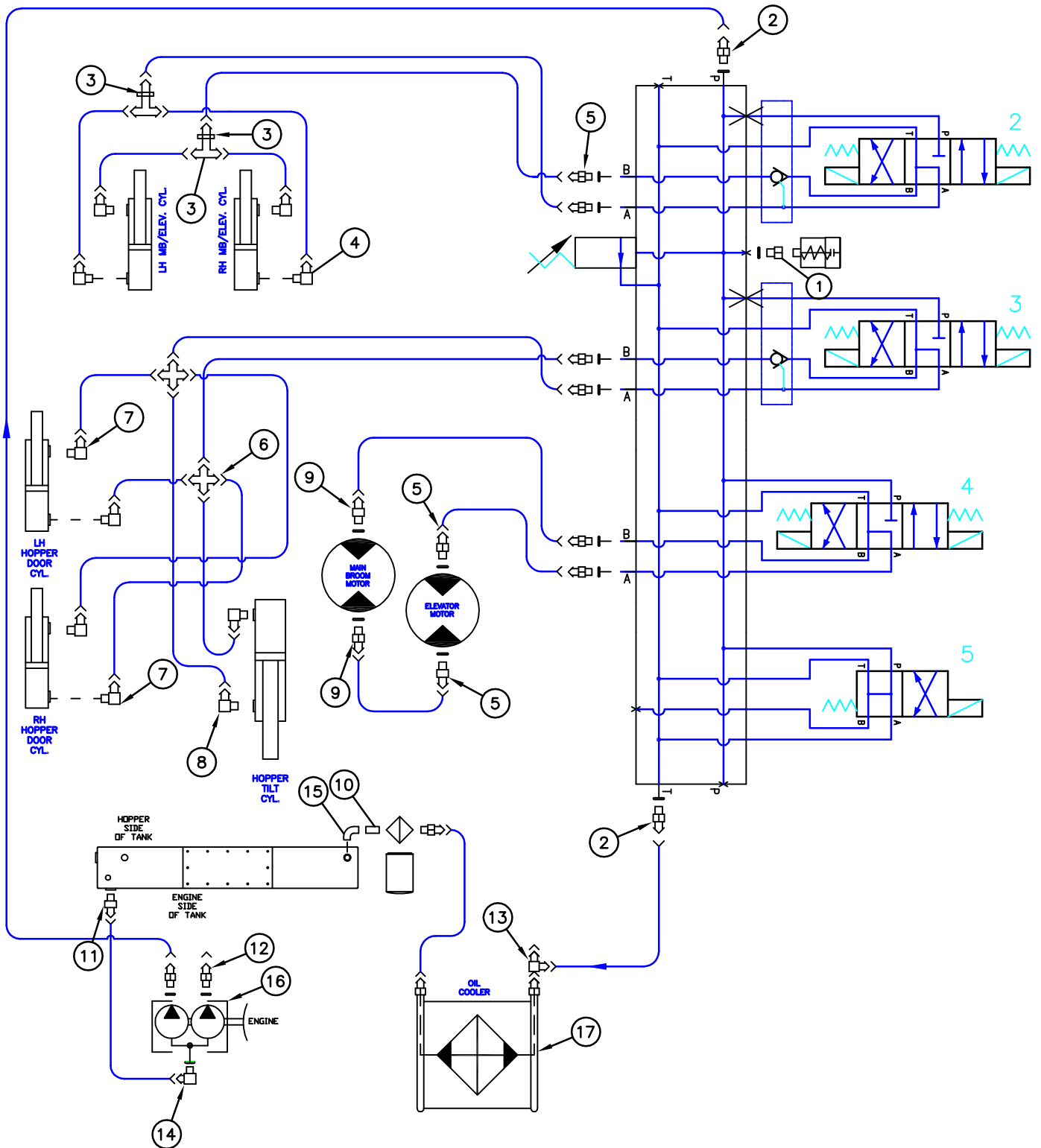

DRIVERS SIDE  
HYDRAULIC FITTING  
SCHEMATIC  
SN 4011 & UP



ITEM	PART #	DESCRIPTION	QTY
1	1816	CONNECTOR	1
2	1836	CONNECTOR	2
3	1802	BULKHEAD UNION	2
4	1804	ELBOW	4
5	1817	CONNECTOR	8
6	1807	CROSS	2
7	1809	ADAPTER	4
8	1812	ELBOW	2
9	1803	45° ELBOW	2
10	1819	NIPPLE	1
11	1826	CONNECTOR	1
12	1825	CONNECTOR	1
13	1815	SWIVEL TEE	1
14	1824	ELBOW	1
15	1820	90° ELBOW	1
16	3203	HYDRAULIC PUMP	1
17	1955	ELECTRIC COOLER	1

# PASSENGERS SIDE HYDRAULIC HOSE SCHEMATIC SN 4011 & UP

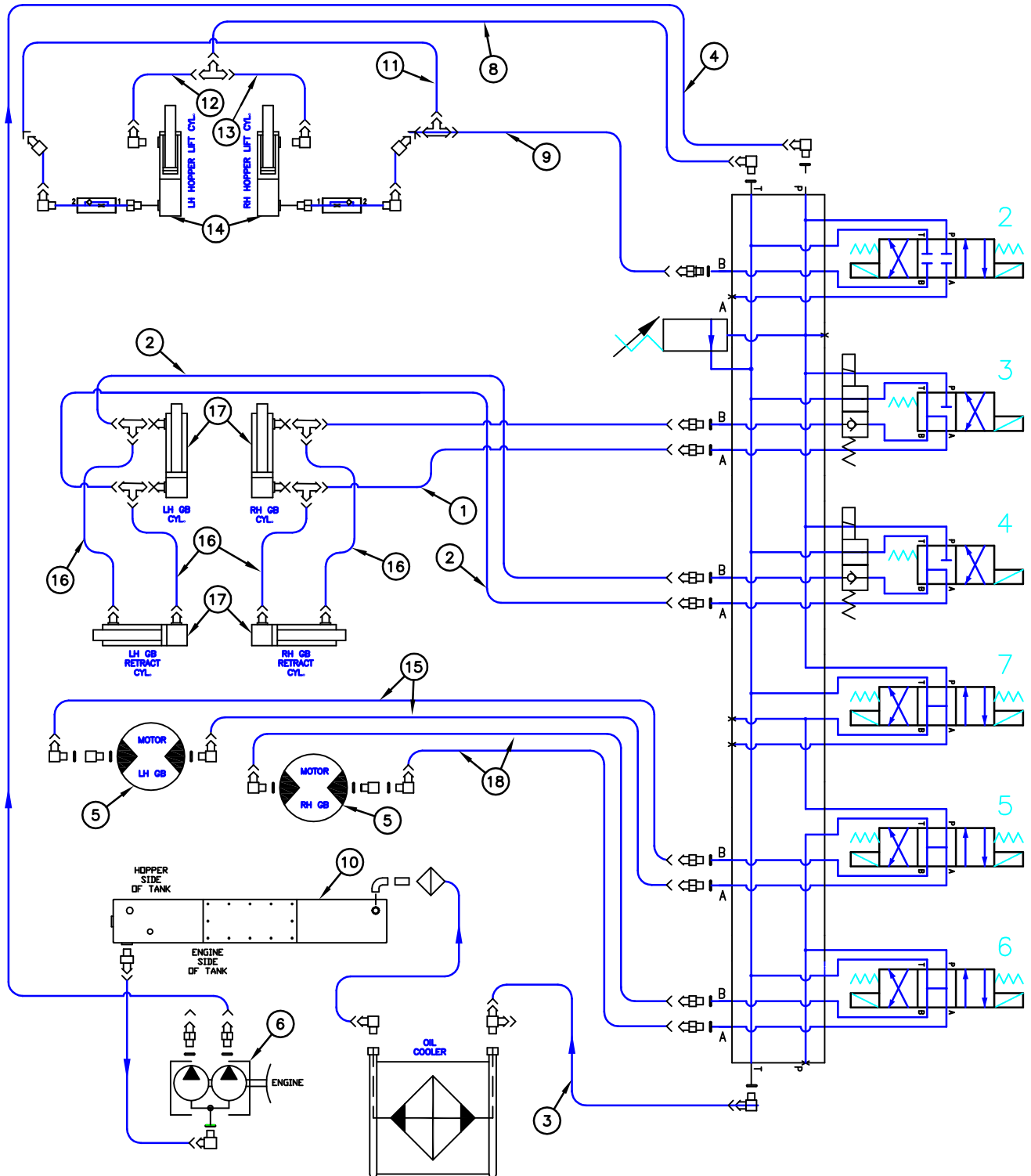



PASSENGERS SIDE  
HYDRAULIC HOSE  
SCHEMATIC  
SN 4011 & UP



ITEM	PART #	DESCRIPTION	QTY
1	1431	HOSE – RH GB CYL. TO VAL.	2
2	1426	HOSE – LH GB CYL. TO VAL.	1
3	1427	HOSE – VALVE RETURN	1
4	1418	HOSE – PUMP TO VALVE	1
5	3230	HYDRAULIC MOTOR	2
6	3203	HYDRAULIC PUMP	–
8	1420	HOSE – HOPPER LIFT RETURN	1
9	1419	HOSE – VALVE TO HOPPER LIFT	1
10	42303	HYDRAULIC TANK	–
11	1421	HOSE – LIFT CROSSOVER	1
12	1422	HOSE – RETURN CROSSOVER	1
13	1423	HOSE – ROD RETURN	1
14	1059	CYLINDER	2
15	1430	HOSE – LH GB MOTOR TO VAL.	2
16	1428	HOSE – RETURN CYLINDER	4
17	1034	GB CYLINDER	4
18	1429	HOSE – RH GB MOTOR TO VAL.	2

# PASSENGERS SIDE HYDRAULIC FITTING SCHEMATIC SN 4011 & UP

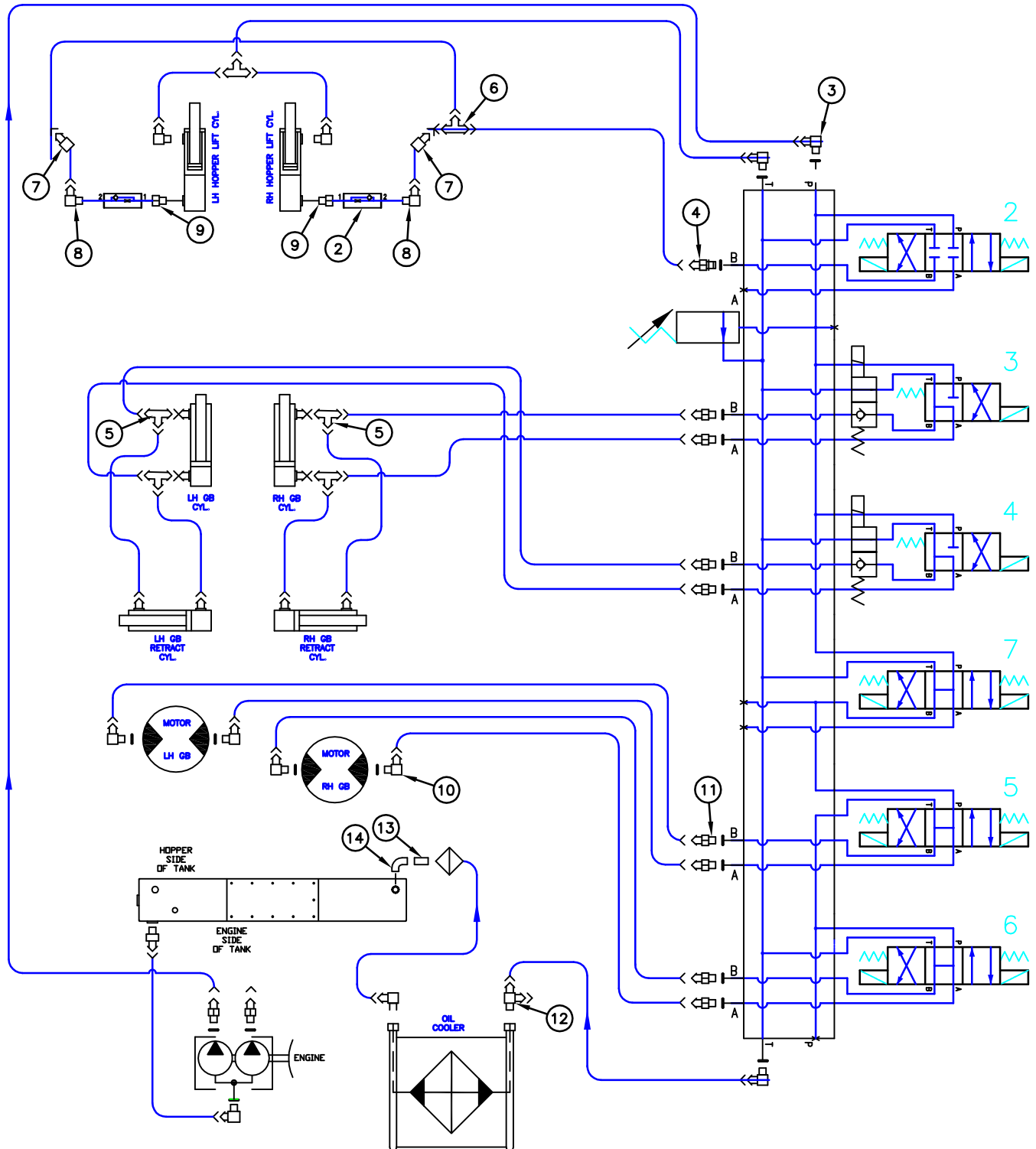

PASSENGERS SIDE  
 HYDRAULIC FITTING  
 SCHEMATIC  
 SN 4011 & UP



ITEM	PART #	DESCRIPTION	QTY
1	1364	PLUG	1
2	2030	DIRECTIONAL RESTR.	2
3	1825	CONNECTOR	2
4	1812	CONNECTOR	14
5	1323	SWIVEL TEE	4
6	1320	TEE	1
7	1324	45° SWIVEL ADAPTER	2
8	1828	ELBOW	4
9	1834	ELBOW	4
10	1811	ELBOW	4
11	1813	90° ADAPTER	2
12	1815	SWIVEL TEE	1
13	1819	NIPPLE	2
14	1820	90° ADAPTER	2

# AUX. ENGINE ASSEMBLY SN 4011 & UP

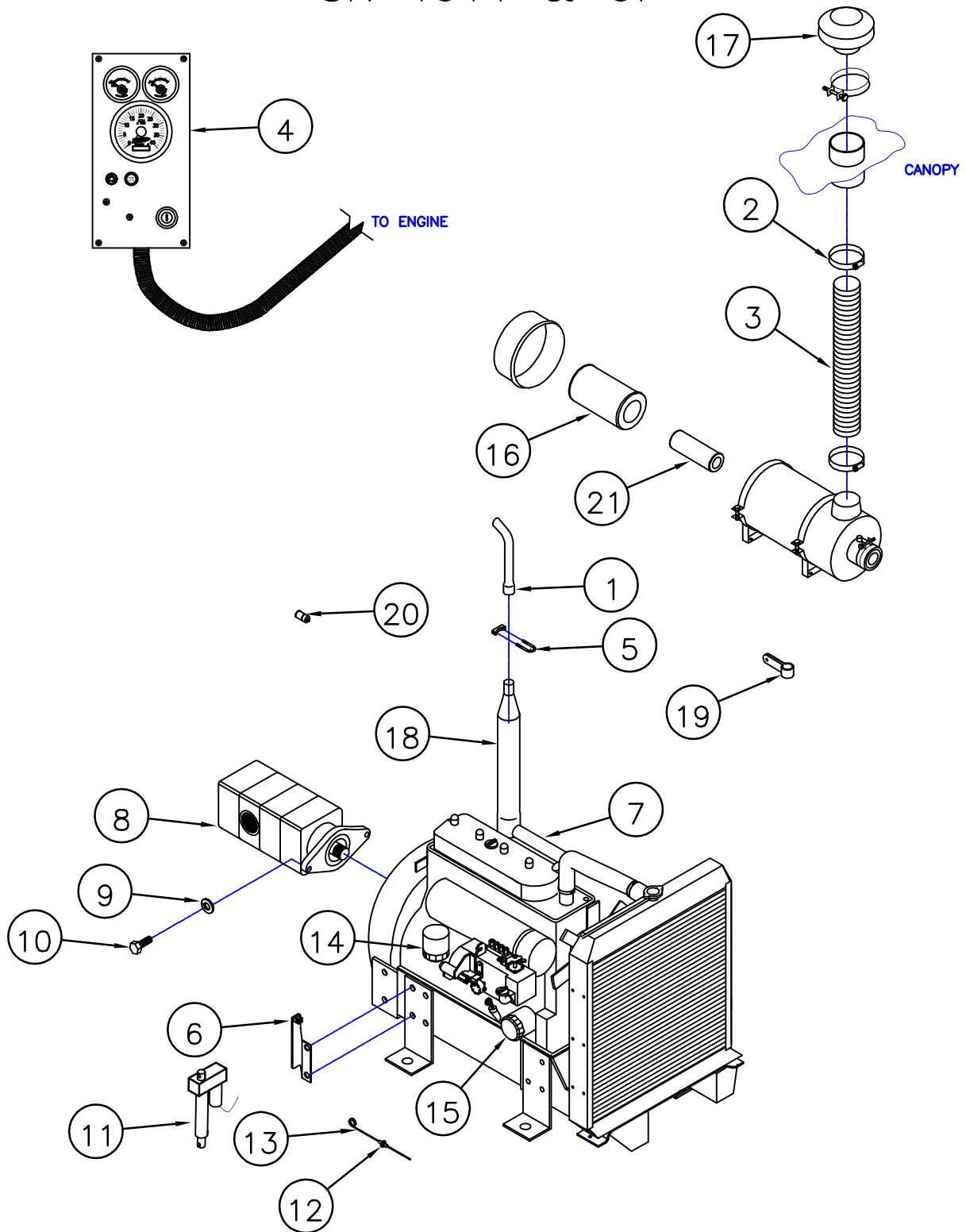



**STEWART-AMOS**

Sweeper Co

AUX. ENGINE  
ASSEMBLY  
SN 4011 & UP

ITEM	PART #	DESCRIPTION	QTY
1	1156	EXHAUST PIPE	1
2	1155	HOSE CLAMP	2
3	1049	INTAKE HOSE	30"
4	42527	ENGINE CONTROL BOX	—
5	1154	EXHAUST CLAMP	1
6	42404	THROTTLE MOUNT	1
7	1118	ENGINE	1
8	3203	HYDRAULIC PUMP	1
9	1524	WASHER	4
10	1545	BOLT	4
11	1387	THROTTLE ACTUATOR	1
12	1299	THROTTLE GUIDE	1
13	1388	THROTTLE ACTUATOR CABLE	1
14	1108	FUEL FILTER	1
15	1106	ENGINE OIL FILTER	1
16	1390	ENGINE OUTER AIR FILTER	1
17	1175	RAIN CAP	1
18	1176	MUFFLER	1
19	1260	CLAMP	1
20	1104	OIL PRESSURE SENDER	1
21	1391	ENGINE INNER AIR FILTER	1

# AUX. ENGINE FRAME ASSEMBLY SN 4011 & UP

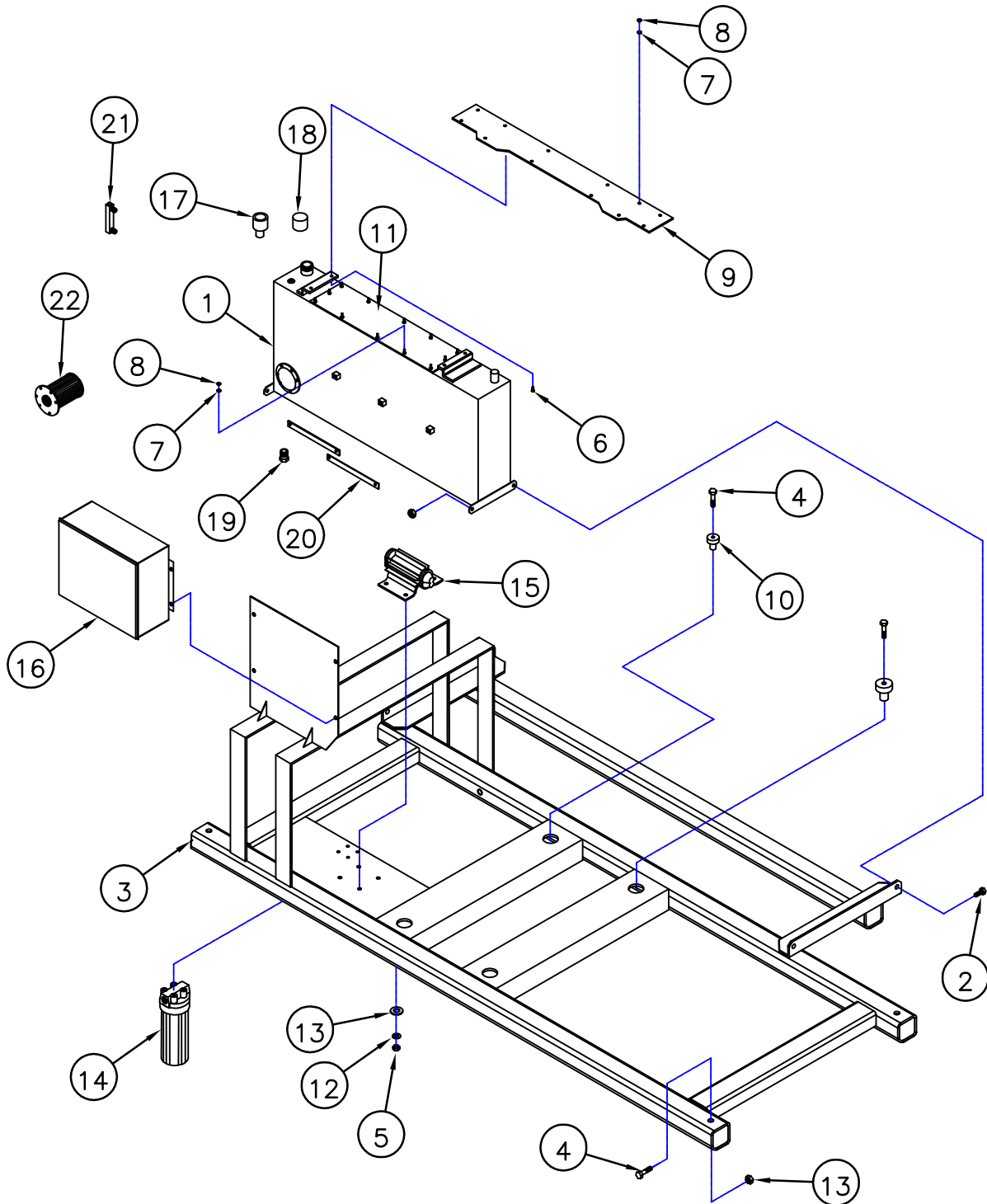



**STEWART-AMOS**

Sweeper Co

AUX. ENGINE  
FRAME ASSEMBLY  
SN 4011 & UP

ITEM	PART #	DESCRIPTION	QTY
1	42303	HYDRAULIC TANK	1
2	1545	BOLT	4
3	42402	AUX. ENGINE FRAME	1
4	1547	BOLT	14
5	1505	NUT	32
6	1535	BOLT	4
7	1521	WASHER	16
8	1502	NUT	16
9	42311	VALVE MOUNT PLATE	1
10	1047	ISOLATION MOUNT	4
11	42305	TANK COVER	1
12	1524	WASHER	4
13	1526	WASHER	4
14	1076	WATER FILTER	—
15	3232	WATER PUMP	—
16	62512	AUX. BOX	—
17	1177	HYD. TANK BREATHER	1
18	1178	FILL CAP	1
19	1179	MAGNETIC DRAIN PLUG	2
20	42310	HOSE TIE STRAP	2
21	1062	SITE GAUGE	1
22	1378	HYD. SUCTION SCREEN	1

# ELEVATOR ASSEMBLY

SN 4011 & UP

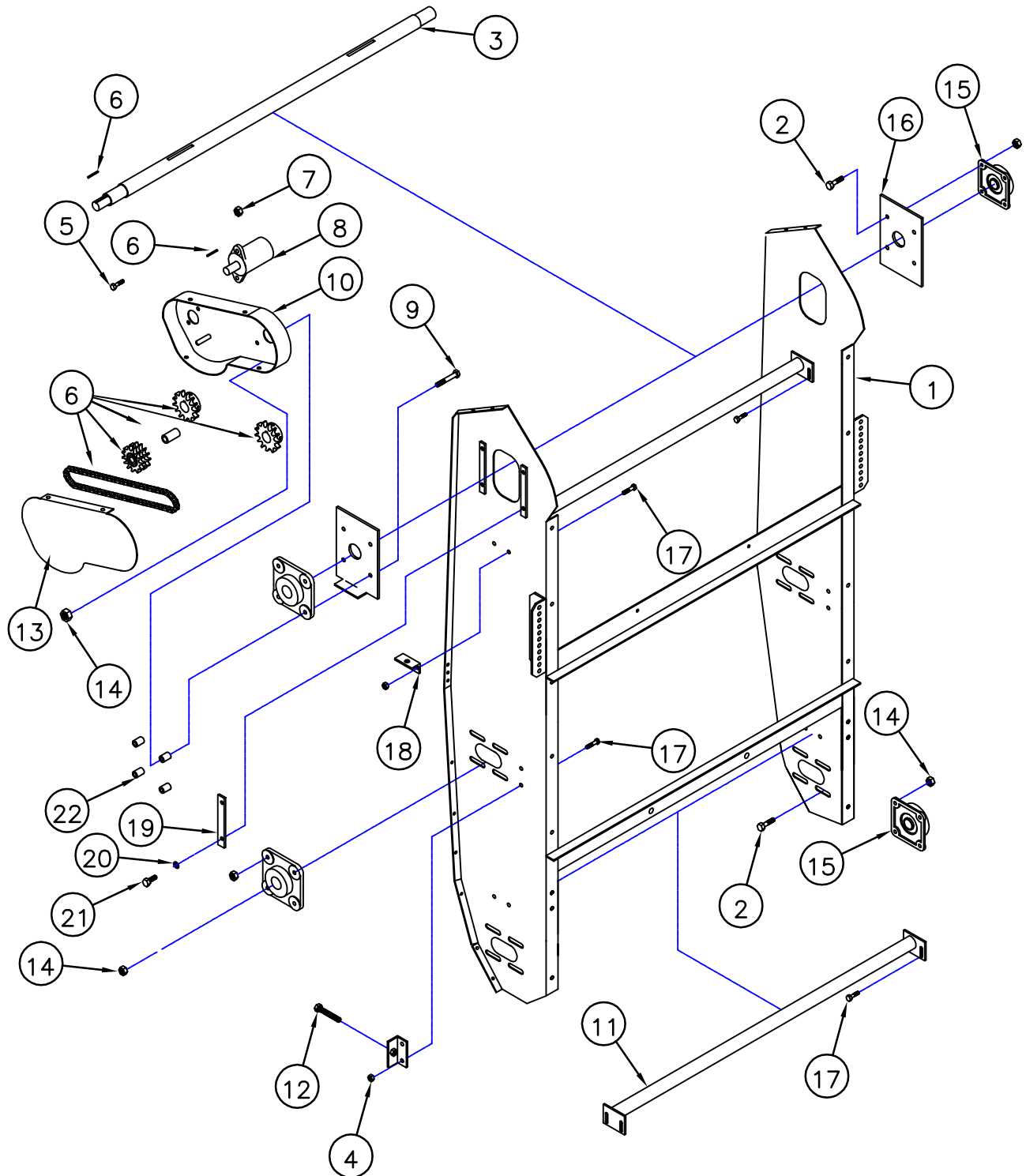





**STEWART-AMOS**

Sweeper Co

ELEVATOR  
ASSEMBLY  
SN 4011 & UP

ITEM	PART #	DESCRIPTION	QTY
1	43103	ELEVATOR FRAME	1
2	1577	BOLT	20
3	43113	TOP SHAFT	1
4	1503	NUT	12
5	1546	BOLT	2
6	80128	ELEV. DRIVE CHAIN ASSEM.	1
7	1505	NUT	2
8	3230	HYDRAULIC MOTOR	1
9	1551	BOLT	4
10	43134	CHAIN GUARD	1
11	43107	SEPARATOR	2
12	1147	BOLT	4
13	43135	COVER	1
14	1506	NUT	24
15	1030	BEARING	6
16	43125	SLIDE	2
17	1540	BOLT	12
18	43127	ADJUSTMENT ANGLE	4
19	43123	GUIDE	4
20	1671	WASHER	8
21	1533	BOLT	8
22	43115	SPACER	4

# ELEVATOR ASSEMBLY

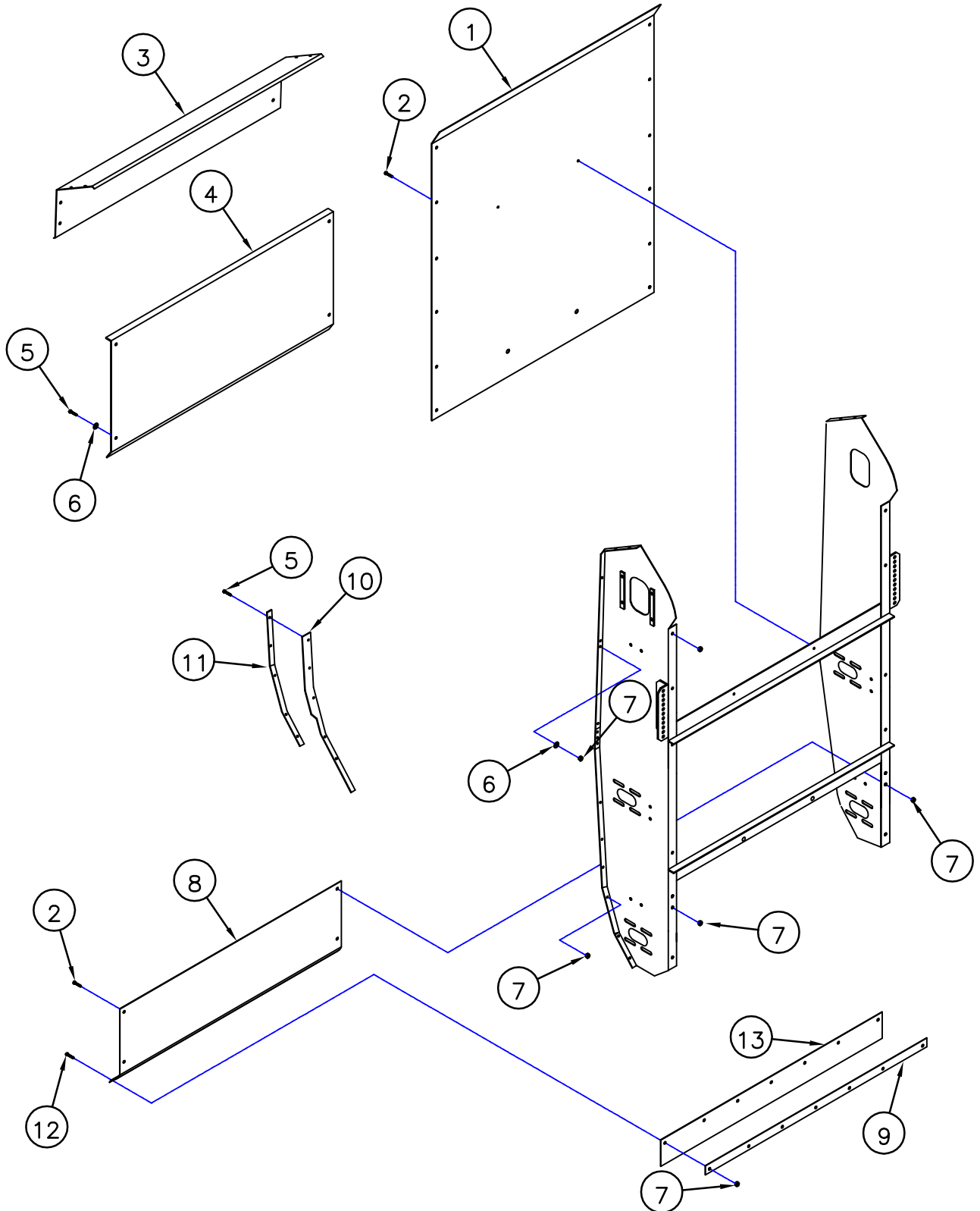



**STEWART-AMOS**

Sweeper Co

## ELEVATOR ASSEMBLY

ITEM	PART #	DESCRIPTION	QTY
1	43111	TOP LINER	1
2	1711	BOLT	14
3	43121	CANOPY	1
4	43131	CANOPY EXTENSION	1
5	1535	BOLT	24
6	1521	WASHER	48
7	1502	NUT	50
8	43105	BOTTOM LINER	1
9	41744	END STRAP	1
10	41776	RUBBER SEAL	2
11	41710	HOLD DOWN	2
12	1713	BOLT	7
13	41772	BOTTOM RUBBER	1

# ELEVATOR ASSEMBLY

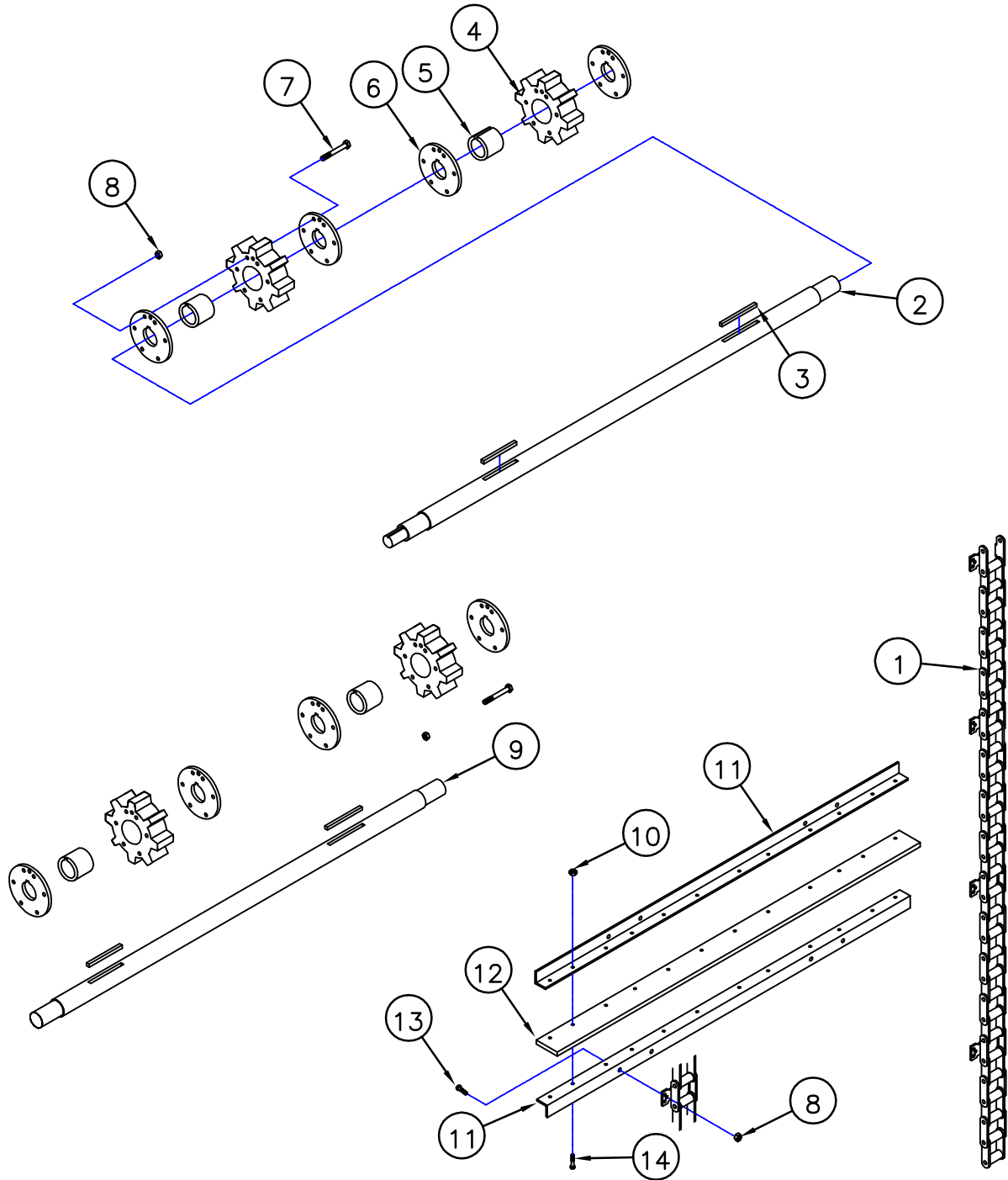



**STEWART-AMOS**

Sweeper Co

## ELEVATOR ASSEMBLY

ITEM	PART #	DESCRIPTION	QTY
1	1007	ELEVATOR CHAIN	2
2	43113	TOP SHAFT	-
3	1149	SHAFT KEY	6
4	1039	RUBBER SPROCKET	6
5	41738	SHAFT SPACER	6
6	41740	LOCK PLATE	12
7	1541	BOLT	42
8	1503	NUT	70
9	43109	BOTTOM AND MIDDLE SHAFT	2
10	1501	NUT	84
11	41728	SQUEEGEE ANGLE	14
12	41726	SQUEEGEE RUBBER	7
13	1537	BOLT	28
14	1531	BOLT	84

# ELEVATOR LIFT ASSEMBLY

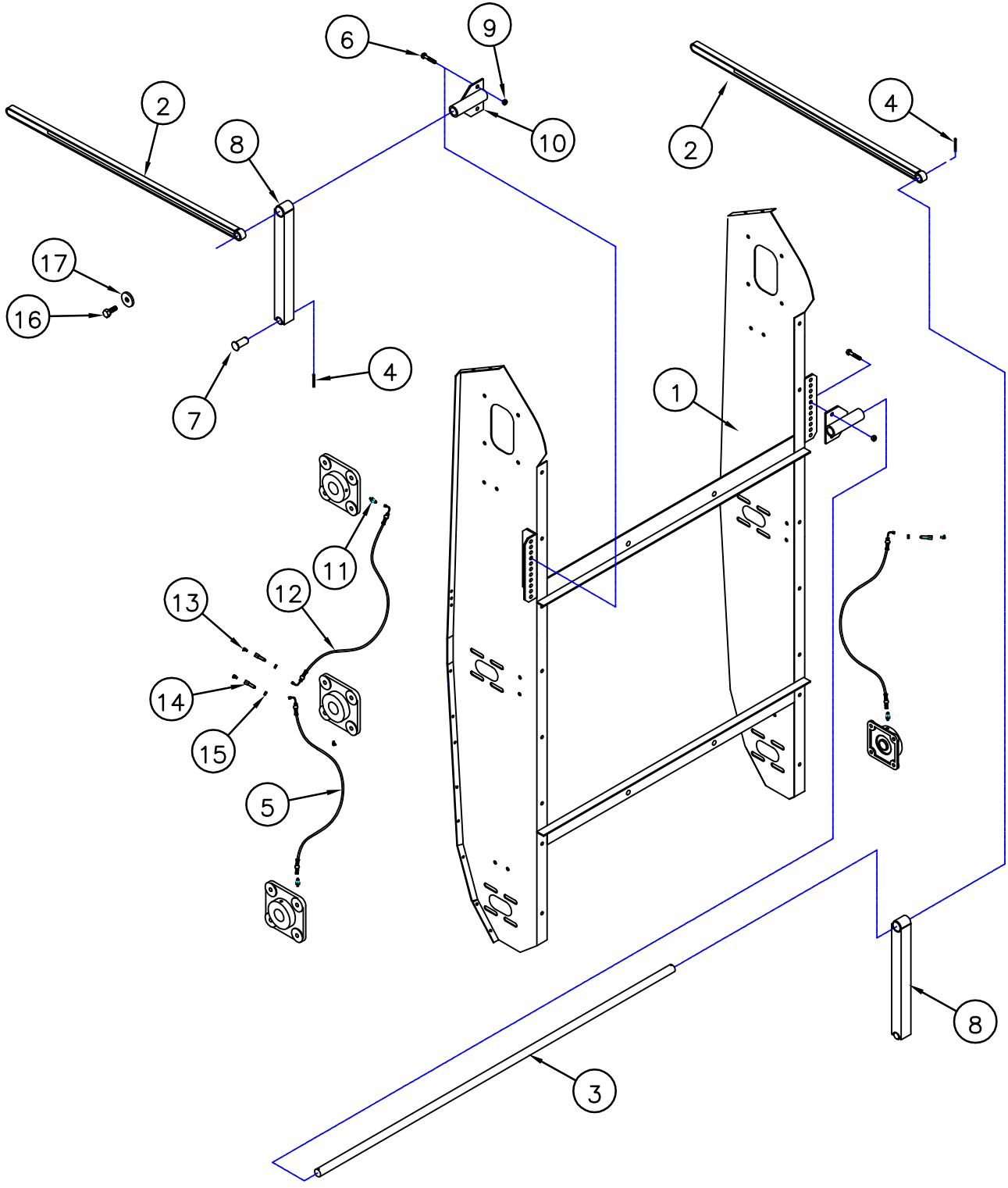



**STEWART-AMOS**

Sweeper Co

## ELEVATOR LIFT ASSEMBLY

ITEM	PART #	DESCRIPTION	QTY
1	43103	ELEVATOR FRAME	—
2	41770	LIFT STRAP	2
3	41764	SWIVEL SHAFT	1
4	1604	COTTER PIN	2
5	1137	HOSE	2
6	1545	BOLT	12
7	41441	PIN	2
8	41766	LIFT ARM	2
9	1505	NUT	12
10	41768	PIVOT SHAFT MOUNT	2
11	1140	FITTING	3
12	1138	HOSE	1
13	1139	GREASE FITTING	6
14	1141	BULKHEAD FITTING	3
15	1142	NUT	3
16	1782	BOLT	2
17	62813	WASHER	2

# WATER SYSTEM

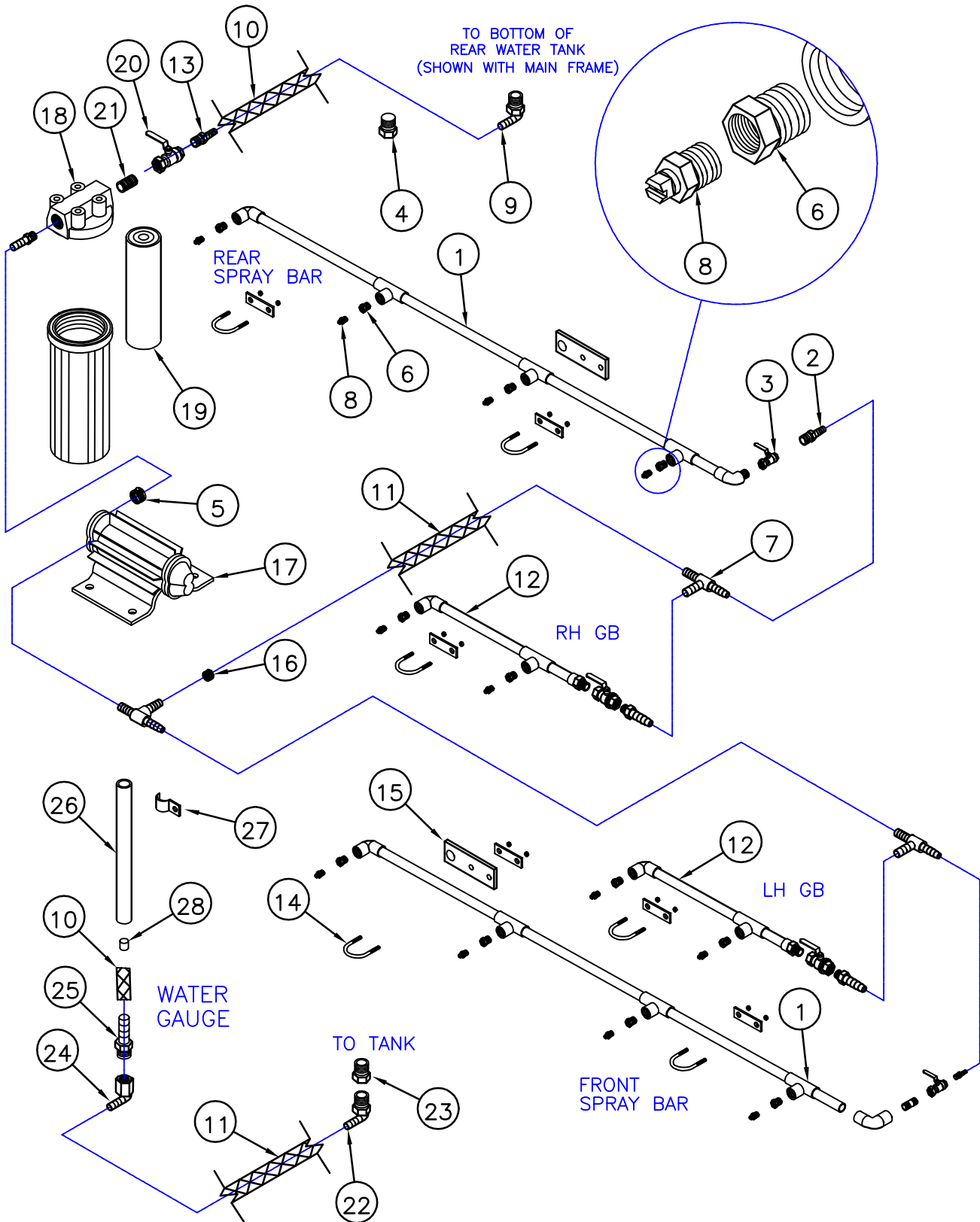



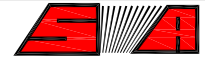

**STEWART-AMOS**

Sweeper Co

## WATER SYSTEM

ITEM	PART #	DESCRIPTION	QTY
1	42201	SPRAY BAR	2
2	1158	HOSE BARB FITTING	4
3	1204	BALL VALVE	4
4	1185	PLUG	1
5	1203	HOSE CLAMP	4
6	1162	ADAPTER	12
7	1163	HOSE BARB TEE ADAPTER	5
8	1164	NOZZLE	12
9	1130	WATER TANK ELBOW	1
10	1165	HOSE	25'
11	1166	HOSE	30'
12	42203	GB SPRAY BAR	2
13	1167	HOSE BARB FITTING	2
14	1168	U BOLT	8
15	42205	SPRAY BAR HANGER	4
16	1169	HOSE CLAMP	20
17	3232	WATER PUMP	1
18	1117	WATER FILTER HOUSING	1
19	1172	WATER FILTER ELEMENT	1
20	1159	BALL VALVE	1
21	1160	NIPPLE	1
22	1371	HOSE BARB FITTING	1
23	1372	ADAPTER	1
24	1373	HOSE BARB FITTING	1
25	1374	HOSE BARB FITTING	1
26	1375	CLEAR TUBING	48"
27	1376	CLAMP	2
28	1377	FLOAT	1

# 42527 ENGINE CONTROL BOX LAYOUT

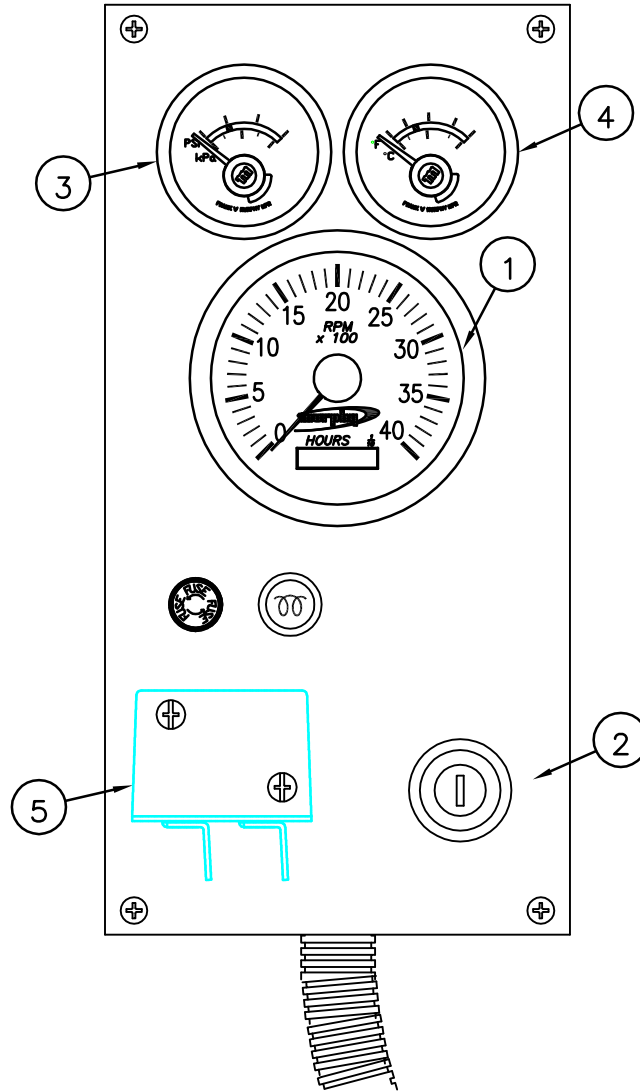

ITEM	PART #	DESCRIPTION	QTY
1	1092	TACH/HOUR METER	1
2	1095	IGNITION SWITCH	1
3	1090	OIL PRESSURE GAUGE	1
4	1091	WATER TEMP GAUGE	1
5	1094	SHUT DOWN MODULE	1



**STEWART-AMOS**

Sweeper Co

# 42527 ENGINE CONTROL BOX SCHEMATIC

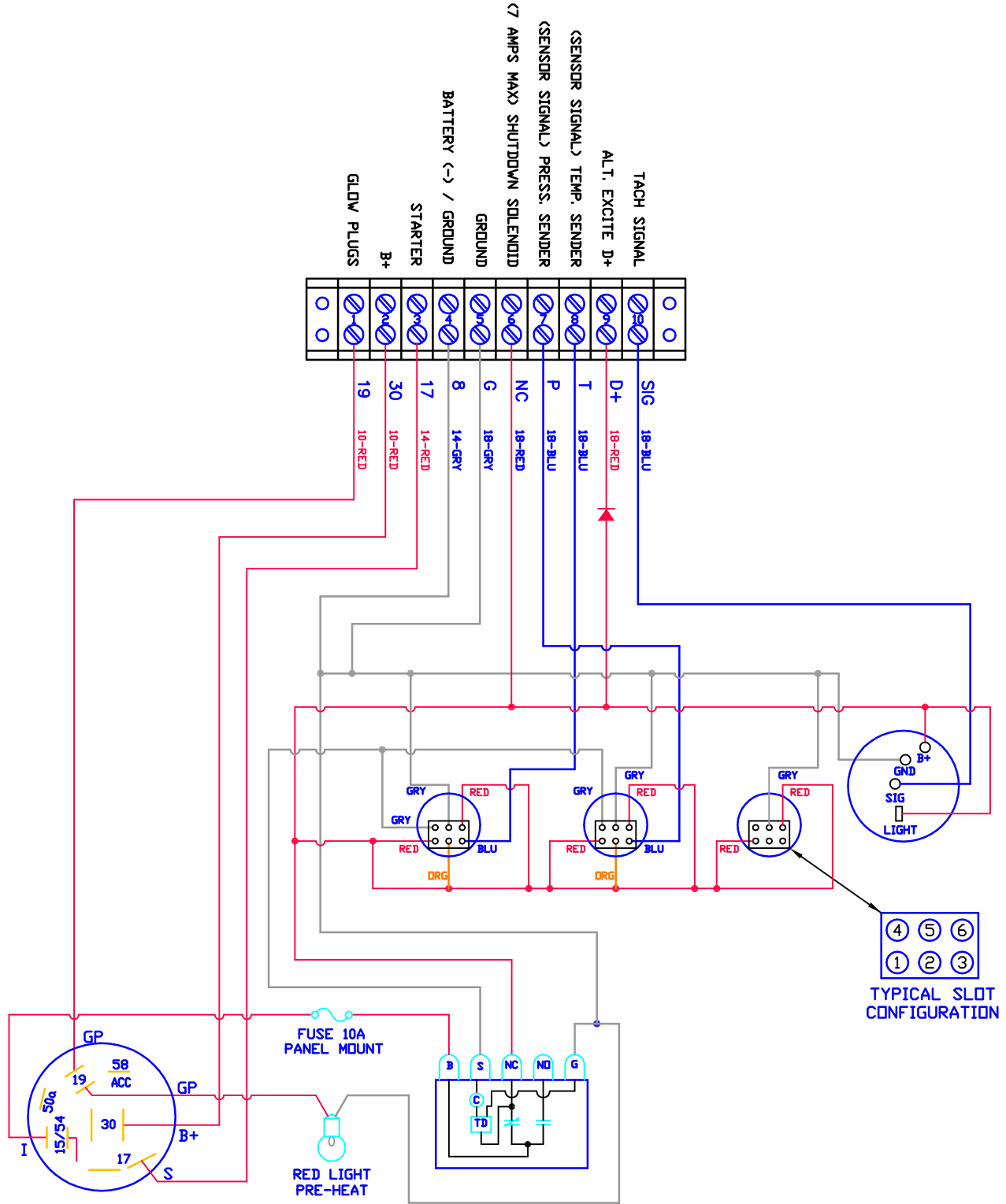

62512  
AUXILIARY CONTROL  
BOX SCHEMATIC

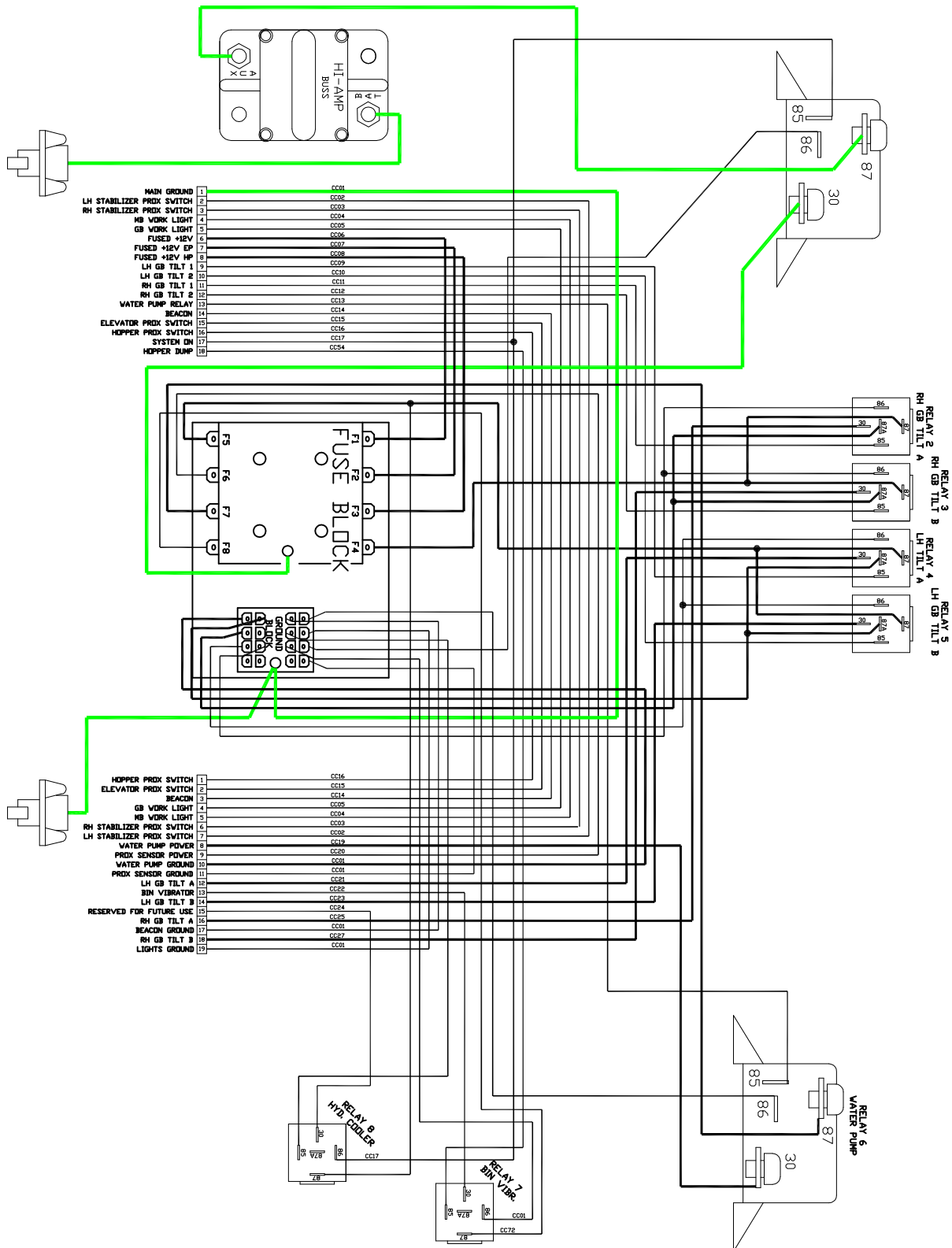

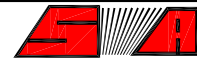

**STEWART-AMOS**

Sweeper Co

# 62512 AUXILIARY CONTROL BOX LAYOUT

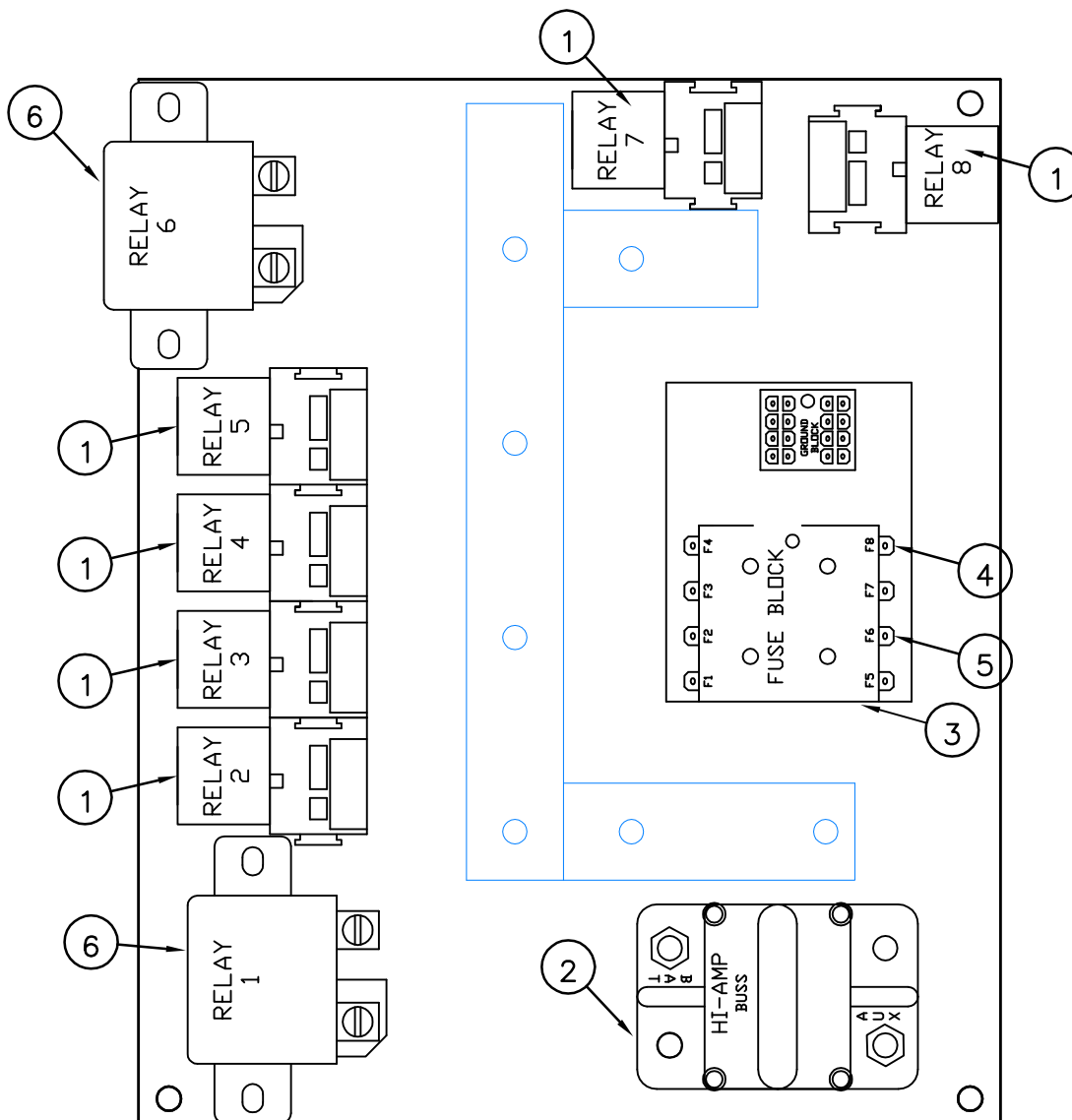

ITEM	PART #	DESCRIPTION	QTY
1	1947	RELAY	6
2	1949	CIRCUIT BREAKER	1
3	2041	FUSE HOLDER 8 POSITION	1
4	2042	FUSE 15 amp F1-5/7/8	7
5	1193	FUSE 5 amp F6	1
6	1946	RELAY	2

# 42517 REAR LIGHT HARNESS

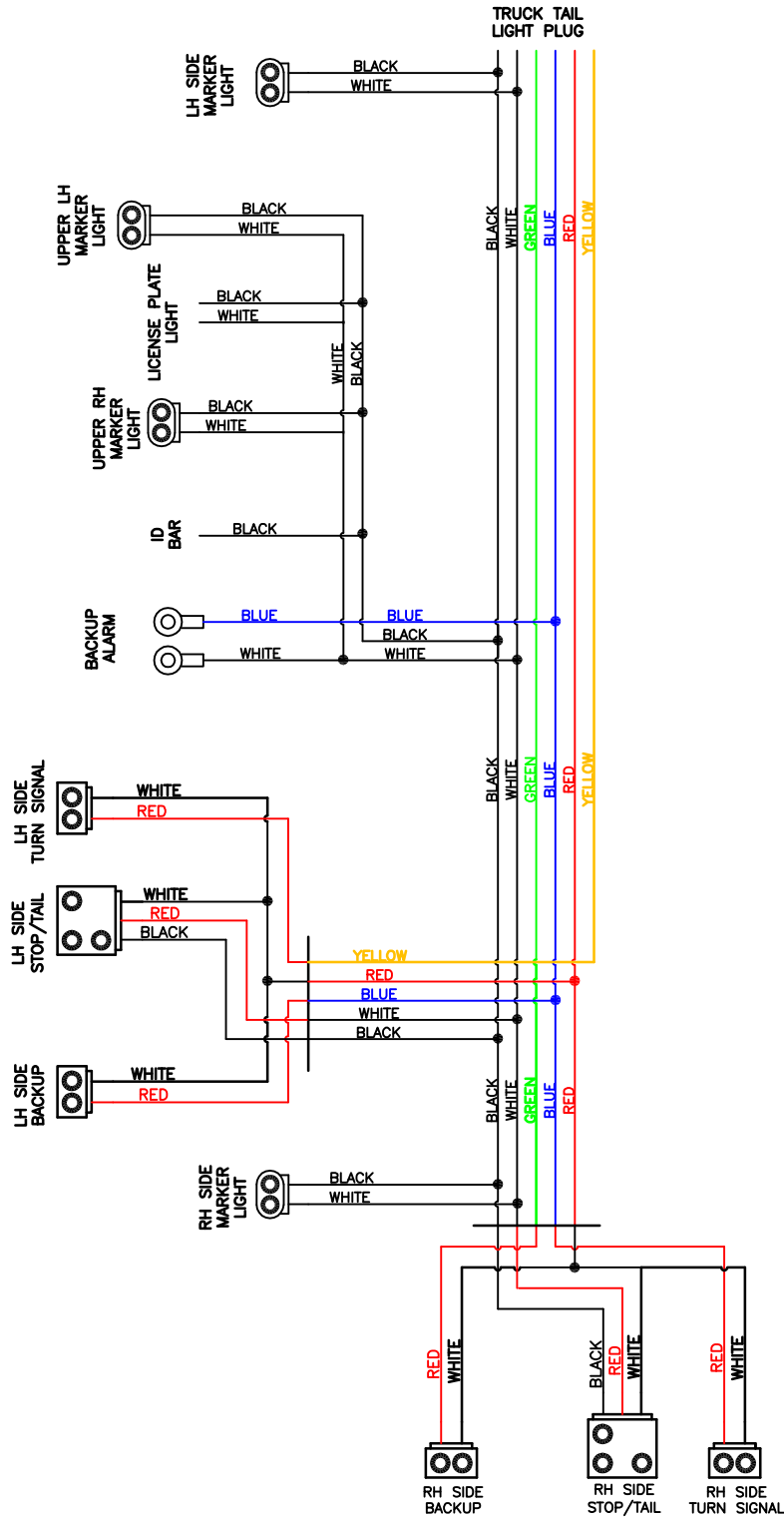



**STEWART-AMOS**

Sweeper Co

# 62511 SWITCH BOX CONTROL SCHEMATIC

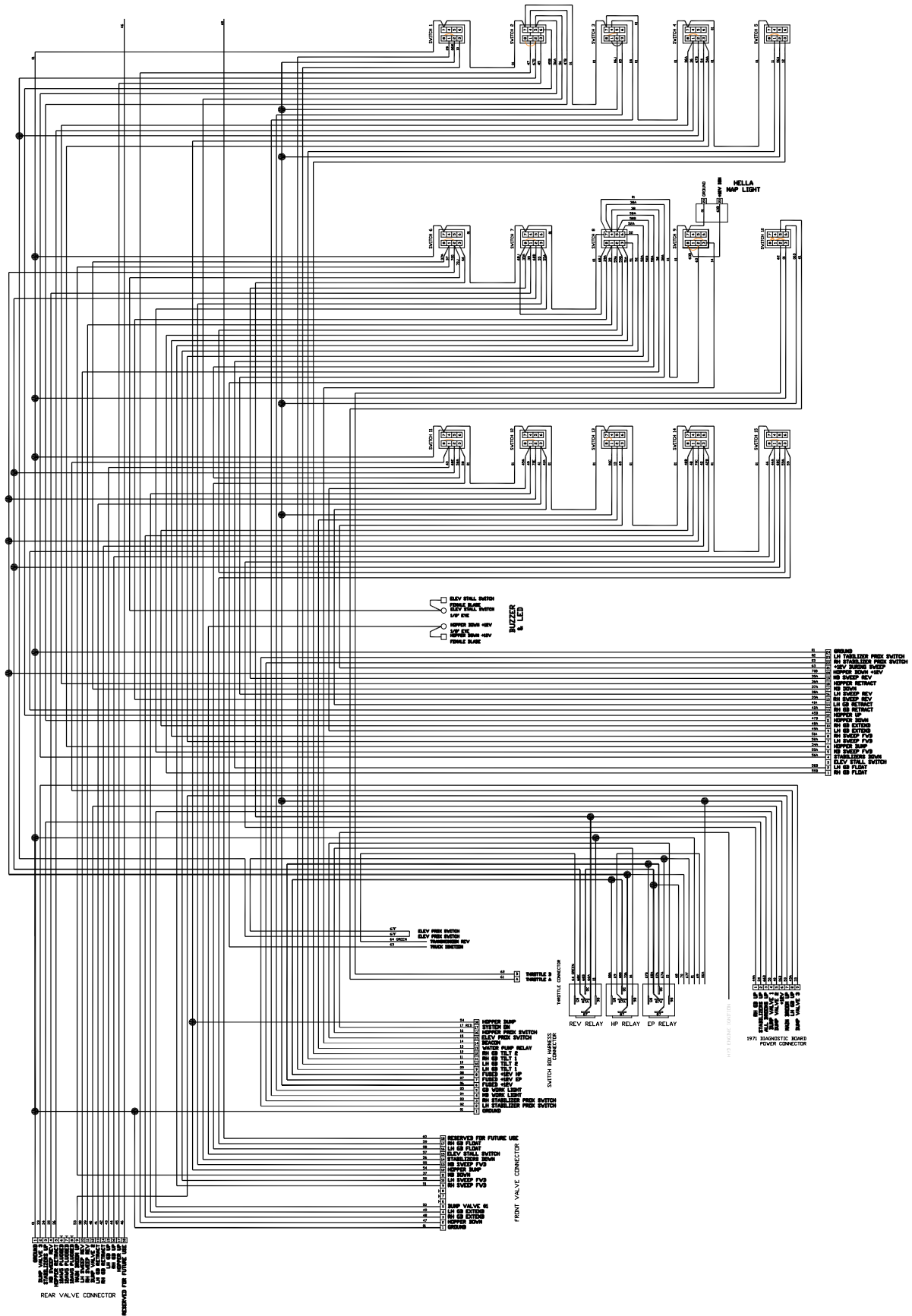

1971 DIAGNOSTIC BOND  
PLUG CONNECTOR

62506  
SWEEPER CONTROL  
PANEL

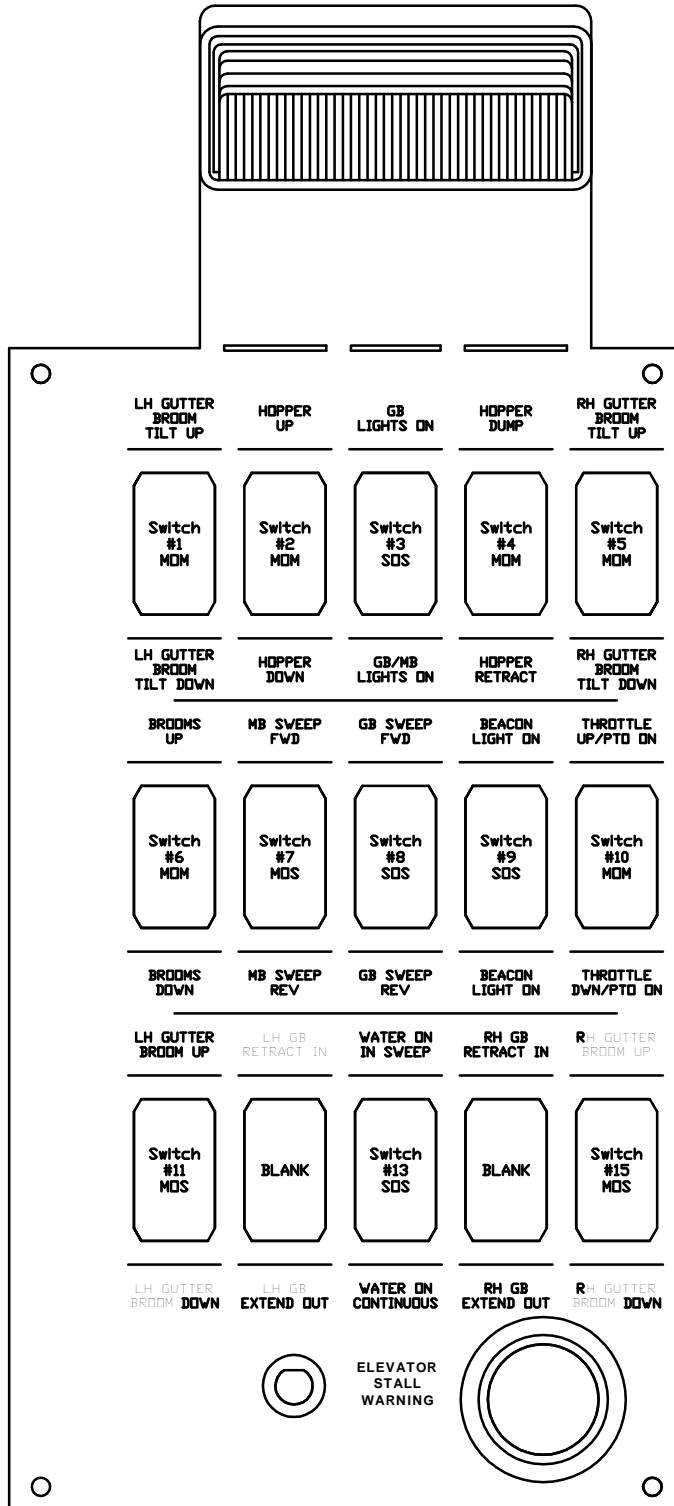



62506  
SWEEPER CONTROL  
BOX



ITEM	PART #	DESCRIPTION	QTY
1	1101	SHOCK MOUNT	4
2	62505	BOX	1
3	62506	PANEL	1
4	42531	PANEL DECAL	1
5	1127	STALL ALARM	1
6	1128	STALL LIGHT	1
7	1686	SWITCH (M-O-M)	6
8	1684	SWITCH (S-O-S)	4
9	1685	SWITCH (S-O-M)	3
10	1689	HOLE PLUG	2
11	1691	COURTESY LIGHT	1

# 62510 VALVE HARNESS

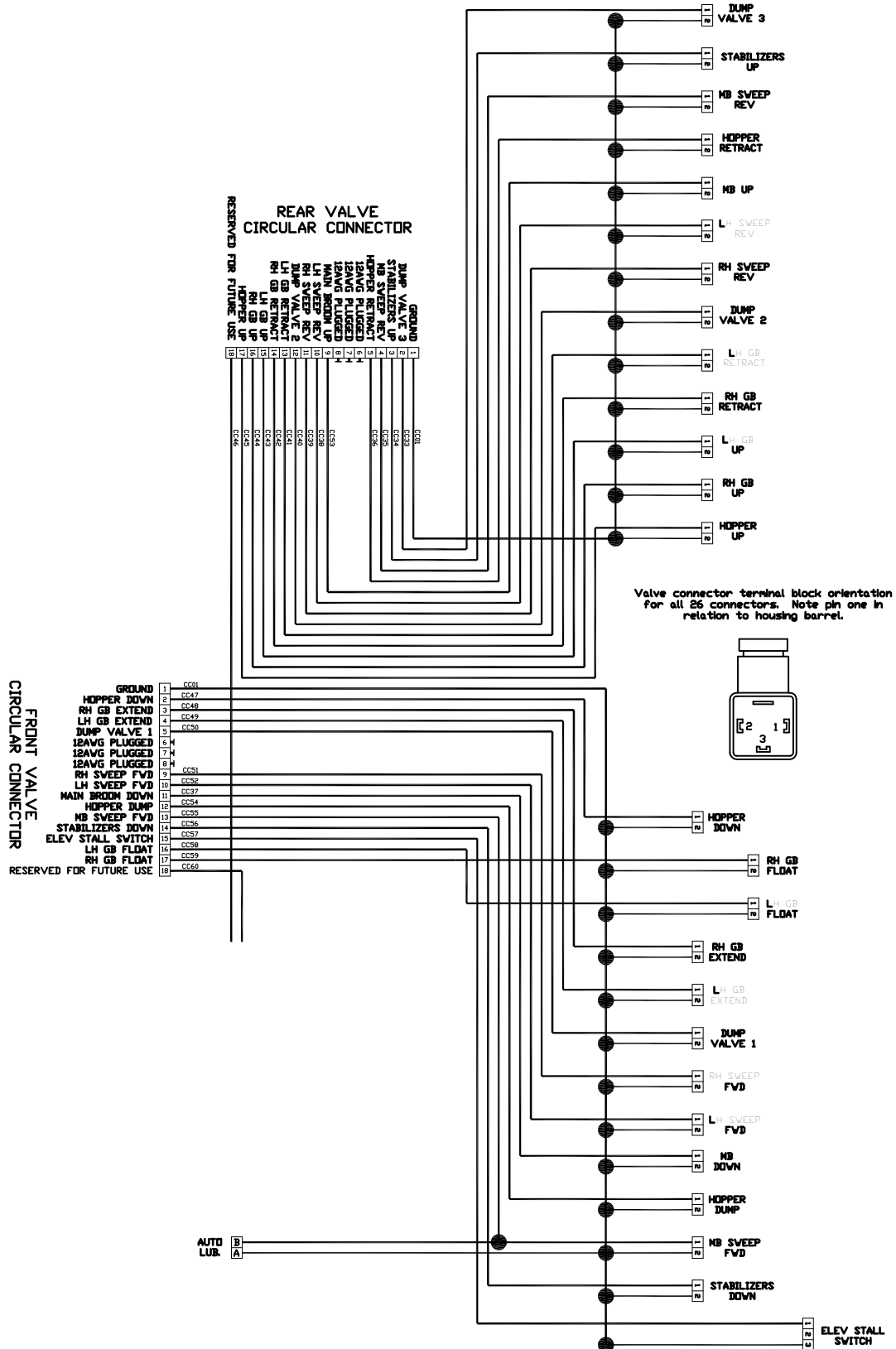



**STEWART-AMOS**

Sweeper Co

# 42542 SWEEPER HARNESS

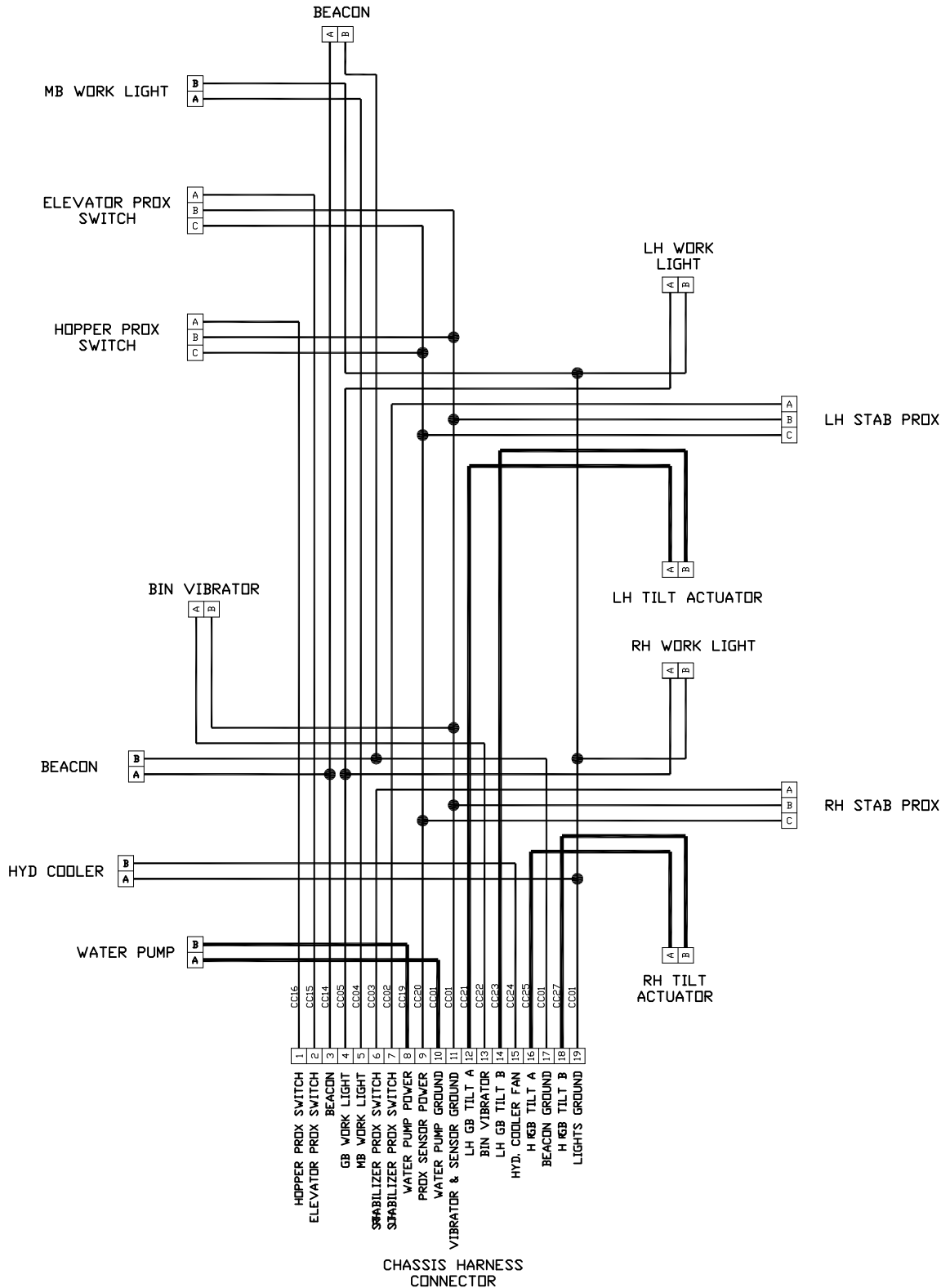

# 42517 REAR LIGHT HARNESS

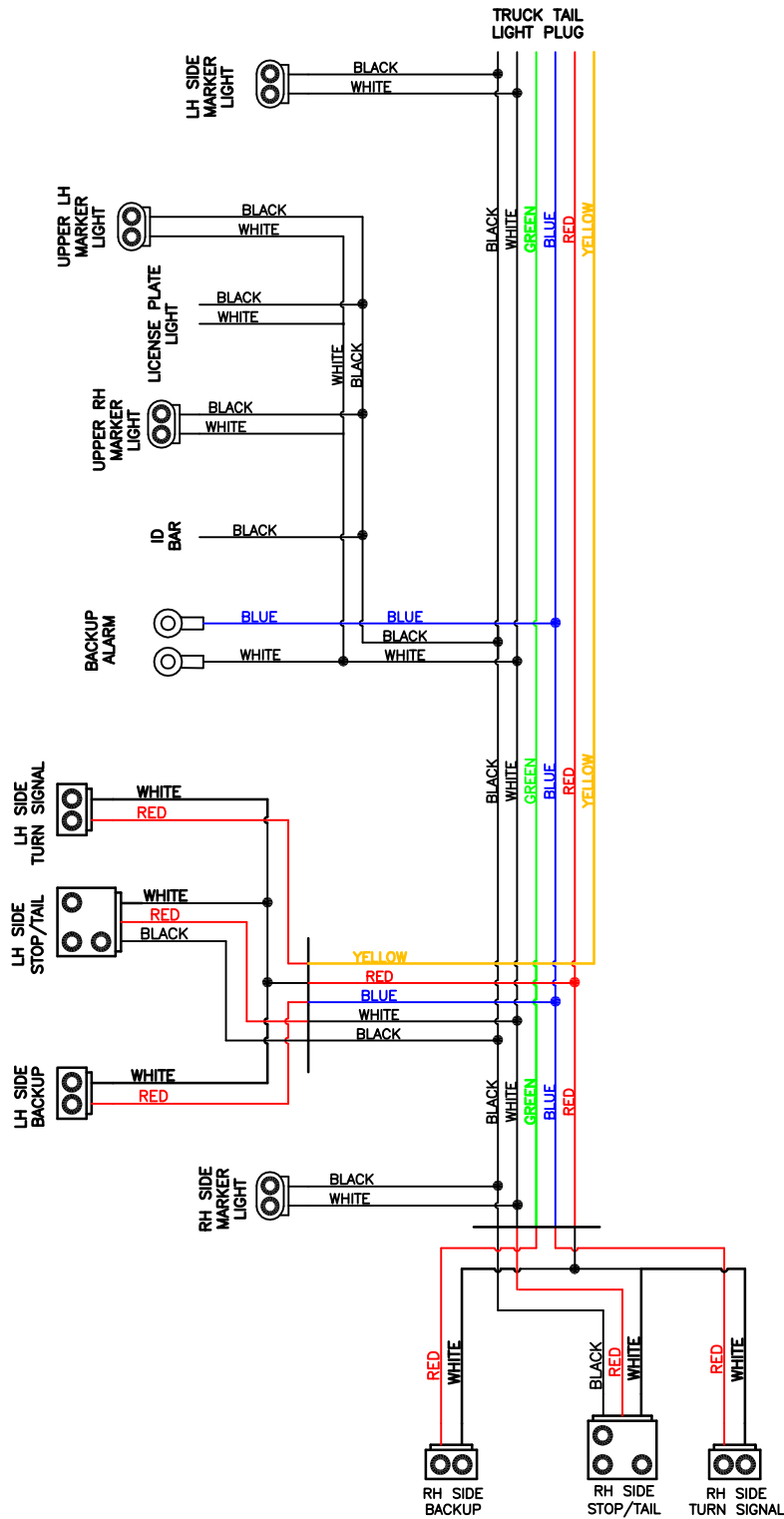

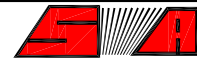

**STEWART-AMOS**

Sweeper Co

## IN CAB PANEL MOUNTING

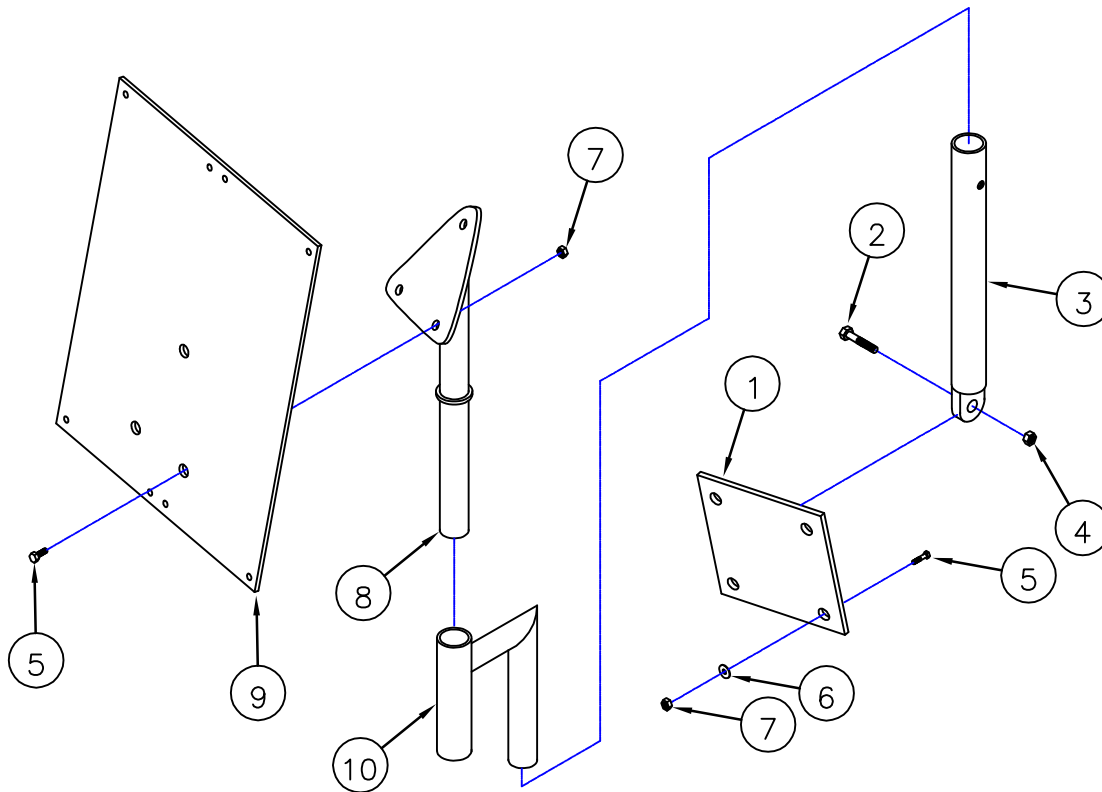

ITEM	PART #	DESCRIPTION	QTY
1	42501	ADAPTER PLATE	1
2	1546	BOLT	1
3	42502	SUPPORT POST	1
4	1505	NUT	1
5	1531	BOLT	7
6	1520	WASHER	4
7	1501	NUT	7
8	42503	TOP MOUNT	1
9	42506	BOX MOUNT PLATE	1
10	42510	OFFSET POST	1



PT # 43201 8/UNIT

*Starfire*  
*S-4*

PT # 43203 1/UNIT



PT # 43205 4/UNIT



PT # 43207 4/UNIT



PT # 43209 2/UNIT



PT # 43211 4/UNIT



# **IMPORTANT**

The operator is responsible for the safe operation of this vehicle. To avoid possible injury or property damage, thoroughly read and understand the operators manual before using this machine.

PT # 43213 1/UNIT



PT # 43215 4/UNIT

**HYDRAULIC OIL  
MUST CONFORM  
TO ISO VG 68  
STANDARDS**

**PT # 43217 2/UNIT**



**This vehicle is equipped  
with a backup alarm.  
Alarm must sound when  
operating this vehicle in  
reverse. Failure to maintain  
a clear view in the direction  
of travel could result in  
serious injury or death.**

**PT # 43219 1/UNIT**

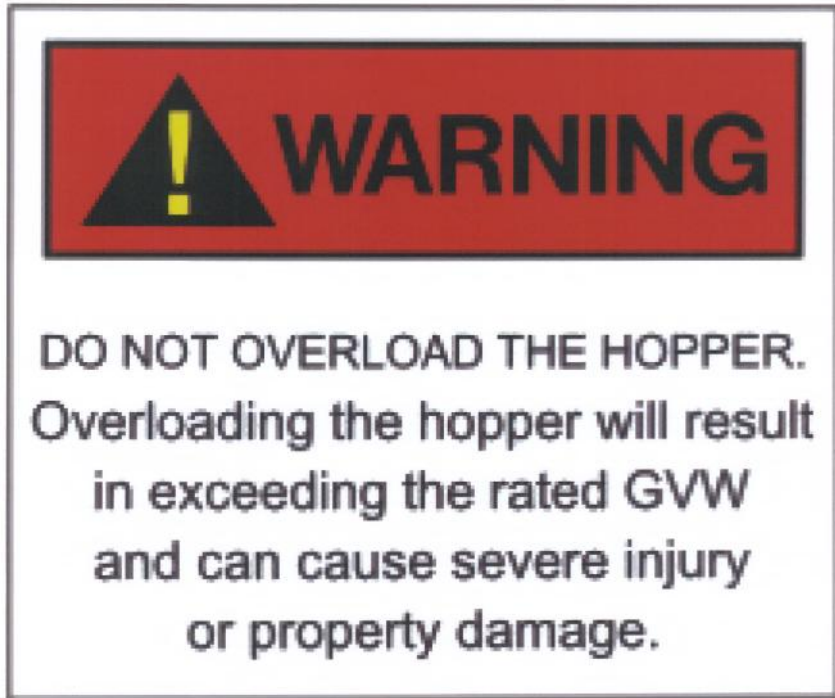

**PT # 43221 1/UNIT**



**PT # 43223 4/UNIT**

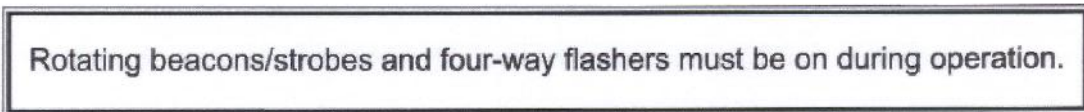

**PT # 43225 1/UNIT**

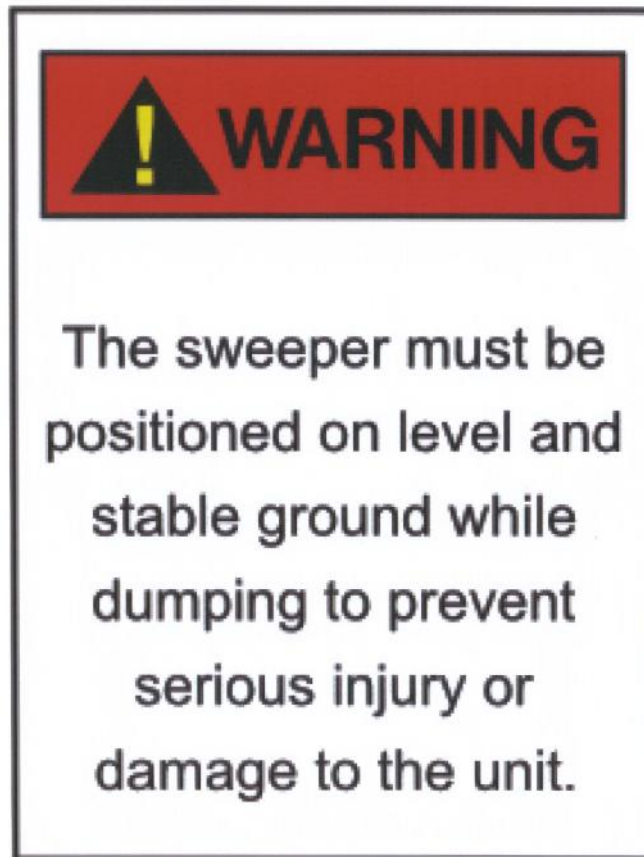

PT # 43227 2/UNIT

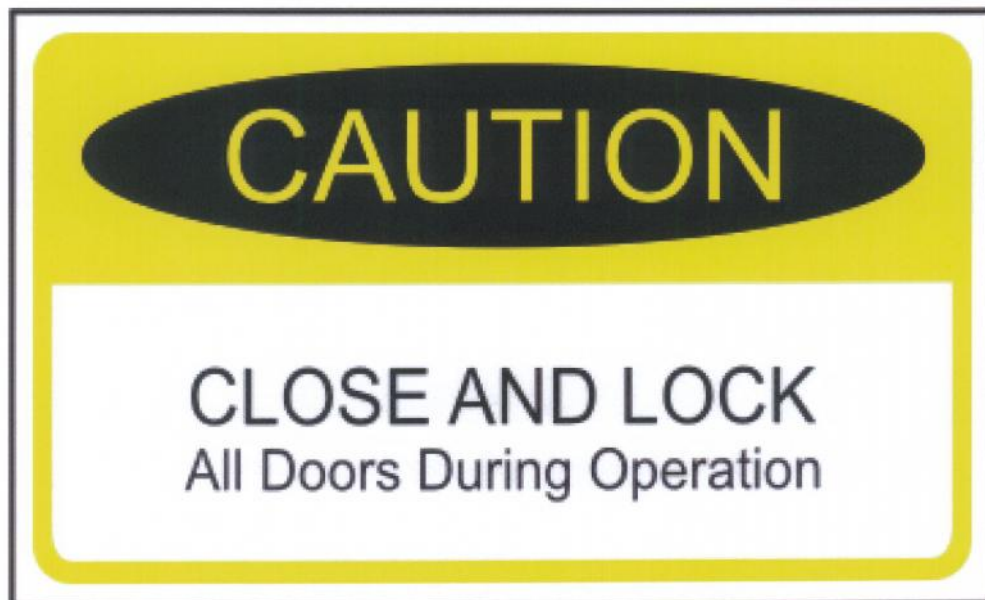

PT # 43229 7/UNIT



PT # 43231 2/UNIT



PT # 43233 2/UNIT



PT # 43235 1/UNIT



PT # 43237 1/UNIT

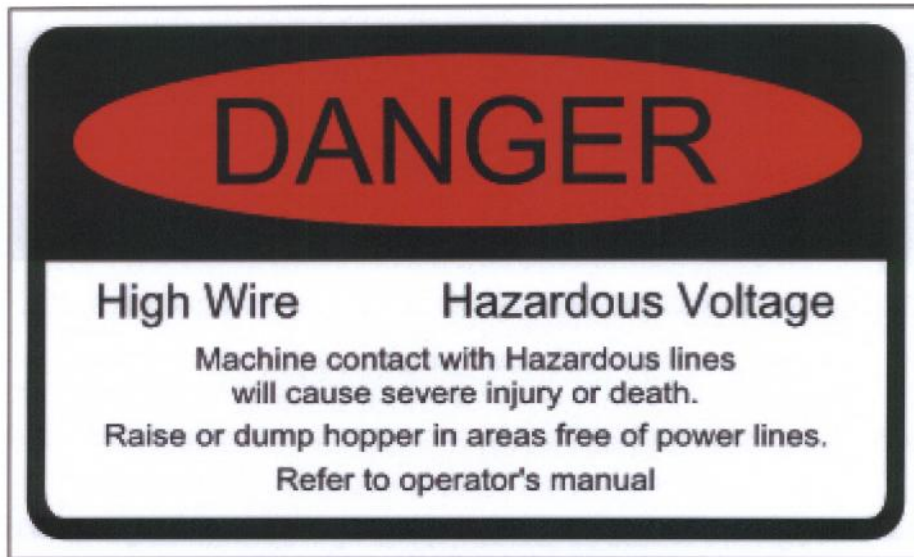

PT # 43239 1/UNIT



PT # 43241 2/UNIT



**STEWART-AMOS**

Sweeper Co.



## INDEX BY PAGE NUMBER

PT #	DESCRIPTION	PG #	PT #	DESCRIPTION	PG #
42001-B	MAIN FRAME	90	1916	STROBE	92
43129	ELEV. CENTERING BUSHING	90	1520	WASHER	92
1502	NUT	90	1501	NUT	92
1535	BOLT	90	1031	HINGE	92
1505	NUT	90	1579	BOLT	92
1143	FENDER	90	1005	DOOR LATCH	92
1537	BOLT	90	1522	WASHER	92
42073	SKIRT	90	1843	BOLT	92
1534	BOLT	90	1750	INSERT	92
42060	REAR SKIRT	90	1559	BOLT	92
42075	BASE STRIP	90	1521	WASHER	92
1822	WASHER	90	1502	NUT	92
42077	BRG. INSPECTION COVER	90	1503	NUT	92
1670	WASHER	90	42107	LIMB GUARD	92
1503	NUT	90	41614	RH REAR DOOR	94
1591	SCREW	90	41612	LH REAR DOOR	94
41771	REST TUBE	90	41503	DOOR	94
1843	BOLT	90	1916	STROBE	94
1075	WATER TANK	90	1005	DOOR LATCH	94
1730	BOLT	90	42081	WATER VALVE LEVER	94
1740	NUT	90	1520	WASHER	94
42085	SAFETY PROP.	90	1024	BACKUP ALARM	94
1573	BOLT	90	1031	HINGE	94
1507	NUT	90	1579	BOLT	94
42065	WATER VALVE	90	1503	NUT	94
1546	BOLT	90	1822	WASHER	94
1640	NUT	90	1843	BOLT	94
42146	CENTER DRAG RUBBER	90	1908	LICENSE PLATE LIGHT	94
42083	WATER VALVE ROD	90	1501	NUT	94
1116	HYDRANT HOSE	90	41602	REAR CANOPY	94
42103	CENTER DRAG SUPPORT	90	1750	INSERT	94
42101	CENTER DRAG RUBBER	90	1905	CLEARANCE LIGHT	94
42507	PROX. MOUNT	90	1906	GROMMET	94
1087-3	PROX. SWITCH	90	1152	CAMERA	94
42214	FILL RELIEF	90	1907	ID BAR	94
1026	WORK LIGHT	90	1911	BACKUP LIGHT	94
42121	MUD FLAP	90	1912	GROMMET	94
42220-06	WATER TANK STRAP	90	1910	TURN SIGNAL LIGHT	94
42220	WATER TANK MOUNT	90	1909	BRAKE LIGHT	94
42147	CENTER DRAG RUBBER	90	1915	WORK LIGHT	94
1572	BOLT	90	42107	LIMB GUARD	94
41503	DOOR	92	42901	HOPPER	96
41501	FRONT CANOPY	92	1185	BUSHING	96



<b>PT #</b>	<b>DESCRIPTION</b>	<b>PG #</b>	<b>PT #</b>	<b>DESCRIPTION</b>	<b>PG #</b>
1033	WINDOW RUBBER	96	1022	TURN BUCKLE	100
42913	WINDOW	96	1023	TURN BUCKLE	100
1031	HINGE	96	1034	CYLINDER	100
1579	BOLT	96	1042	QUICK LINK	100
1005	DOOR LATCH	96	1502	NUT	100
1501	NUT	96	1505	NUT	100
62907	ACCESS DOOR	96	1506	NUT	100
1520	WASHER	96	1507	NUT	100
42907	HOPPER DOOR	96	1508	NUT	100
42909	PIN	96	1822	WASHER	100
42905	DOOR LINK	96	1581	WASHER	100
1503	NUT	96	1526	WASHER	100
1530	BOLT	96	1534	BOLT	100
42915	RUBBER FLASHING	96	1539	BOLT	100
42917	UPRIGHT FLASHING	96	1556	BOLT	100
1560	BOLT	96	1559	BOLT	100
1061	CYLINDER	96	1560	BOLT	100
1558	BOLT	96	1561	BOLT	100
1583	NUT	96	1553	BOLT	100
43001	HOPPER LIFT FRAME	98	1640	NUT	100
1185	BUSHING	98	1642	NUT	100
1621	PIN	98	1670	WASHER	100
1060	CYLINDER	98	41201	GB MOUNT LH	100
1604	COTTER PIN	98	41203	GB PIVOT LH	100
1059	CYLINDER	98	41205	LINKAGE MOUNT LH	100
42813	SCISSOR ROLLER	98	41211	PIN	100
1074	SNAP RING	98	41213	PIN	100
62812	CENTER PIN	98	41215	SPRING BELL CRANK	100
42809	SCISSOR PIN	98	41217	LINK	100
42803	LOWER SCISSOR, ANCHOR	98	41221	LINK	100
42801	LOWER SCISSOR, ROLLER	98	41229	ADJUSTMENT LINK	100
42807	UPPER SCISSOR, ANCHOR	98	41314	GB MOUNT RH	100
42805	UPPER SCISSOR, ROLLER	98	41316	LINKAGE MOUNT RH	100
42819	UPPER SCISSOR, ANCHOR	98	41322	GB PIVOT RH	100
42821	UPPER SCISSOR, ANCHOR	98	1010	BUSHING C/W 3 BOLTS, 3 WASHERS	102
42815	LOWER SCISSOR, ANCHOR	98	1078	LINEAR ACTUATOR	102
42817	LOWER SCISSOR, ANCHOR	98	1145	OFFSET KEY	102
42130	SAFETY MOUNT	98	1148	GB BRUSH SET 32" PLATE	102
42131	SAFETY	98	1157	HYDRAULIC MOTOR	102
62813	WASHER	98	1505	NUT	102
1782	BOLT	98	1506	NUT	102
42132	HOPPER SAFETY MOUNT	98	1822	WASHER	102
1018	SUSPENSION SPRING	100	1525	WASHER	102
1019	RETRACT SPRING	100	1526	WASHER	102
1020	BUSHING	100	1537	BOLT	102

<b>PT #</b>	<b>DESCRIPTION</b>	<b>PG #</b>	<b>PT #</b>	<b>DESCRIPTION</b>	<b>PG #</b>
1546	BOLT	102	41427	MAIN BROOM LIFT CHAIN	104
1540	BOLT	102	41437	DRAG SHOE LIFT CHAIN	104
1549	BOLT	102	61401	MAIN BROOM LIFT ARM LH	104
1670	WASHER	102	62813	WASHER	104
3230	HYDRAULIC MOTOR	102	1018	SUSPENSION SPRING	106
41207	MOTOR BRACKET LH	102	1023	TURN BUCKLE	106
41209	DRIVE HUB	102	1045	EYE BOLT	106
41227	32" PLATE	102	1115	CARBIDE DRAG SHOE	106
41318	MOTOR BRACKET RH	102	1185	BUSHING	106
1014	MAIN BROOM MANDREL	104	1501	NUT	106
1016	MAIN BROOM STRIP SET	104	1502	NUT	106
1030	BEARING	104	1503	NUT	106
1043	CYLINDER	104	1508	NUT	106
1044	BEARING	104	1521	WASHER	106
1046	SHOCK	104	1527	WASHER	106
80126	MAIN BROOM COUPLER	104	1530	BOLT	106
1145	OFFSET KEY	104	1534	BOLT	106
1157	HYDRAULIC MOTOR	104	1537	BOLT	106
1185	BUSHING	104	1562	BOLT	106
3213-4	SHORT MANDRELL SHAFT	104	1575	BOLT	106
3212	LONG MANDRELL SHAFT	104	1639	NUT	106
1266	END PLATE	104	1640	NUT	106
1503	NUT	104	1630	CAPSCREW	106
1505	NUT	104	1670	WASHER	106
1822	WASHER	104	1822	WASHER	106
1527	WASHER	104	41401	PIN	106
1537	BOLT	104	41415	PRES. CONTROL ROCK SHAFT	106
1781	BOLT	104	41423	PRES. CONTROL ARM LH	106
1545	BOLT	104	41425	PRES. CONTROL ARM RH	106
1546	BOLT	104	41429	DRAG LINK	106
1843	BOLT	104	41431	BACKING	106
1604	COTTER PIN	104	41433	DRAG SHOE MOUNT LH	106
1639	NUT	104	41435	DRAG SHOE MOUNT RH	106
1630	CAPSCREW	104	42067	DIRT DEFLECTOR RUBBER	106
1669	WASHER	104	1293	MANIFOLD	107
1670	WASHER	104	2001	VALVE	107
1671	WASHER	104	1989	VALVE	107
3230	HYDRAULIC MOTOR	104	1295	VALVE	107
41405	LIFT BELL CRANK LH	104	2000	RELIEF VALVE	107
41407	LIFT BELL CRANK RH	104	1990	FLOAT VALVE	107
41409	MAIN BROOM LIFT ARM LH	104	1839	RESTRICTOR	107
41411	MAIN BROOM LIFT ARM RH	104	1287	MANIFOLD	108
41413	MAIN BROOM ROCK SHAFT	104	1993	VALVE	108
41417	PIN	104	1291	VALVE	108
41421	MAIN BROOM LIFT STRAP	104	2000	RELIEF VALVE	108

<b>PT #</b>	<b>DESCRIPTION</b>	<b>PG #</b>	<b>PT #</b>	<b>DESCRIPTION</b>	<b>PG #</b>
1994	CHECK VALVE	108	1418	HOSE	114
2010	CHECK VALVE	108	3230	MOTOR	114
1839	RESTRICTOR	108	3203	PUMP	114
1037	ELEVATOR STALL SWITCH	110	1420	HOSE	114
1401	HOSE	110	1419	HOSE	114
1402	HOSE	110	42303	TANK	114
1403	HOSE	110	1421	HOSE	114
1404	HOSE	110	1422	HOSE	114
1405	HOSE	110	1423	HOSE	114
3230	MOTOR	110	1059	CYLINDER	114
1406	HOSE	110	1430	HOSE	114
1407	HOSE	110	1428	HOSE	114
1408	HOSE	110	1034	CYLINDER	114
1061	CYLINDER	110	1429	HOSE	114
1409	HOSE	110	1364	PLUG	116
1043	CYLINDER	110	2030	RESTRICTOR	116
1410	HOSE	110	1825	CONNECTOR	116
1411	HOSE	110	1812	CONNECTOR	116
1417	HOSE	110	1323	TEE	116
1412	HOSE	110	1320	TEE	116
1060	CYLINDER	110	1324	ADAPTOR	116
1413	HOSE	110	1828	ELBOW	116
1414	HOSE	110	1834	ELBOW	116
1415	HOSE	110	1811	ELBOW	116
1416	FILTER	110	1813	ADAPTOR	116
1816	CONNECTOR	112	1815	TEE	116
1836	CONNECTOR	112	1819	NIPPLE	116
1802	UNION	112	1820	ADAPTOR	116
1804	ELBOW	112	1156	PIPE	118
1817	CONNECTOR	112	1155	CLAMP	118
1807	CROSS	112	1049	HOSE	118
1809	ADAPTOR	112	42527	CONTROL BOX	118
1812	ELBOW	112	1154	CLAMP	118
1803	ELBOW	112	42404	MOUNT	118
1819	NIPPLE	112	1118	ENGINE	118
1826	CONNECTOR	112	3203	PUMP	118
1825	CONNECTOR	112	1524	WASHER	118
1815	SWIVEL	112	1545	BOLT	118
1824	ELBOW	112	1387	ACTUATOR	118
1820	ELBOW	112	1299	GUIDE	118
3203	PUMP	112	1388	CABLE	118
1955	COOLER	112	1108	FILTER	118
1431	HOSE	114	1106	FILTER	118
1426	HOSE	114	1390	FILTER	118
1427	HOSE	114	1175	CAP	118

<b>PT #</b>	<b>DESCRIPTION</b>	<b>PG #</b>	<b>PT #</b>	<b>DESCRIPTION</b>	<b>PG #</b>
1176	MUFFLER	118	1533	BOLT	122
1260	CLAMP	118	43115	SPACER	122
1104	SENDER	118	43111	TOP LINER	124
1391	FILTER	118	1711	BOLT	124
42303	TANK	120	43121	CANOPY	124
1545	BOLT	120	43131	EXTENSION	124
42402	ENGINE FRAME	120	1535	BOLT	124
1547	BOLT	120	1521	WASHER	124
1505	NUT	120	1502	NUT	124
1535	BOLT	120	43105	BOTTOM LINER	124
1521	WASHER	120	41744	END STRAP	124
1502	NUT	120	41776	SEAL	124
42311	MOUNTING PLATE	120	41710	HOLD DOWN	124
1047	MOUNT	120	1713	BOLT	124
42305	COVER	120	41772	BOTTOM RUBBER	124
1524	WASHER	120	1007	ELEV. CHAIN	126
1526	WASHER	120	43113	SHAFT	126
1076	FILTER	120	1149	KEY	126
3232	PUMP	120	1039	SPROCKET	126
62512	AUX. BOX	120	41738	SPACER	126
1177	BREATHER	120	41740	PLATE	126
1178	CAP	120	1541	BOLT	126
1179	PLUG	120	1503	NUT	126
42310	TIE STRAP	120	43109	SHAFT	126
1062	SITE GAUGE	120	1501	NUT	126
1378	SCREEN	120	41728	ANGLE	126
43103	FRAME	122	41726	RUBBER	126
1577	BOLT	122	1537	BOLT	126
43113	SHAFT	122	1531	BOLT	126
1503	NUT	122	43103	FRAME	128
80128	BOLT	122	41770	STRAP	128
1505	CHAIN ASSM.	122	41764	SHAFT	128
3230	NUT	122	1604	COTTER PIN	128
1551	MOTOR	122	1137	HOSE	128
43134	BOLT	122	1545	BOLT	128
43107	GUARD	122	41441	PIN	128
1147	SEPARATOR	122	41766	ARM	128
43135	BOLT	122	1505	NUT	128
1506	COVER	122	41768	SHAFT MOUNT	128
1030	NUT	122	1140	FITTING	128
43125	BEARING	122	1138	HOSE	128
1540	SLIDE	122	1139	FITTING	128
43127	BOLT	122	1141	FITTING	128
43123	ANGLE	122	1142	NUT	128
1671	GUIDE	122	1782	BOLT	128

<b>PT #</b>	<b>DESCRIPTION</b>	<b>PG #</b>	<b>PT #</b>	<b>DESCRIPTION</b>	<b>PG #</b>
62813	WASHER	128	62506	PANEL	138
42201	SPRAY BAR	130	42531	DECAL	138
1158	FITTING	130	1127	ALARM	138
1204	VALVE	130	1128	LIGHT	138
1185	PLUG	130	1686	SWITCH	138
1203	CLAMP	130	1684	SWITCH	138
1162	ADAPTER	130	1685	SWITCH	138
1163	ADAPTER	130	1689	PLUG	138
1164	NOZZLE	130	1691	LIGHT	138
1130	ELBOW	130	62510	HARNESS	139
1165	HOSE	130	42542	HARNESS	140
1166	HOSE	130	42517	HARNESS	141
42203	SPRAY BAR	130	42501	PLATE	142
1167	CLAMP	130	1546	BOLT	142
1168	PUMP	130	42502	POST	142
42205	FILTER HOUSING	130	1505	NUT	142
1169	FILTER ELEMENT	130	1531	BOLT	142
3232	VALVE	130	1520	WASHER	142
1117	NIPPLE	130	1501	NUT	142
1172	FITTING	130	42503	MOUNT	142
1159	VALVE	130	42506	PLATE	142
1160	NIPPLE	130	42510	POST	142
1371	FITTING	130			
1372	ADAPTER	130			
1373	FITTING	130			
1374	FITTING	130			
1375	TUBE	130			
1376	CLAMP	130			
1377	FLOAT	130			
1092	TACH	131			
1095	SWITCH	131			
1090	GAUGE	131			
1091	GAUGE	131			
1094	MODULE	131			
62512	HARNESS	133			
1947	RELAY	134			
1949	BREAKER	134			
2041	FUSE HOLDER	134			
2042	FUSE	134			
1193	FUSE	134			
1946	RELAY	134			
42517	HARNESS	135			
62511	HARNESS	136			
1101	MOUNT	138			
62505	BOX	138			

## INDEX BY PART NUMBER

PT #	DESCRIPTION	PG #	PT #	DESCRIPTION	PG #
1005	DOOR LATCH	92	1076	FILTER	120
1005	DOOR LATCH	94	1078	LINEAR ACTUATOR	102
1005	DOOR LATCH	96	1090	GAUGE	131
1007	ELEV. CHAIN	126	1091	GAUGE	131
1010	BUSHING C/W 3 BOLTS, 3 WASHERS	102	1092	TACH	131
1014	MAIN BROOM MANDREL	104	1094	MODULE	131
1016	MAIN BROOM STRIP SET	104	1095	SWITCH	131
1018	SUSPENSSION SPRING	100	1101	MOUNT	138
1018	SUSPENSSION SPRING	106	1104	SENDER	118
1019	RETRACT SPRING	100	1106	FILTER	118
1020	BUSHING	100	1108	FILTER	118
1022	TURN BUCKLE	100	1115	CARBIDE DRAG SHOE	106
1023	TURN BUCKLE	100	1116	HYDRANT HOSE	90
1023	TURN BUCKLE	106	1117	NIPPLE	130
1024	BACKUP ALARM	94	1118	ENGINE	118
1026	WORK LIGHT	90	1127	ALARM	138
1030	BEARING	104	1128	LIGHT	138
1030	NUT	122	1130	ELBOW	130
1031	HINGE	92	1137	HOSE	128
1031	HINGE	94	1138	HOSE	128
1031	HINGE	96	1139	FITTING	128
1033	WINDOW RUBBER	96	1140	FITTING	128
1034	CYLINDER	100	1141	FITTING	128
1034	CYLINDER	114	1142	NUT	128
1037	ELEVATOR STALL SWITCH	110	1143	FENDER	90
1039	SPROCKET	126	1145	OFFSET KEY	102
1042	QUICK LINK	100	1145	OFFSET KEY	104
1043	CYLINDER	104	1147	SEPARATOR	122
1043	CYLINDER	110	1148	GB BRUSH SET 32" PLATE	102
1044	BEARING	104	1149	KEY	126
1045	EYE BOLT	106	1152	CAMERA	94
1046	SHOCK	104	1154	CLAMP	118
1047	MOUNT	120	1155	CLAMP	118
1049	HOSE	118	1156	PIPE	118
1059	CYLINDER	98	1157	HYDRAULIC MOTOR	102
1059	CYLINDER	114	1157	HYDRAULIC MOTOR	104
1060	CYLINDER	98	1158	FITTING	130
1060	CYLINDER	110	1159	VALVE	130
1061	CYLINDER	96	1160	NIPPLE	130
1061	CYLINDER	110	1162	ADAPTER	130
1062	SITE GAUGE	120	1163	ADAPTER	130
1074	SNAP RING	98	1164	NOZZLE	130
1075	WATER TANK	90	1165	HOSE	130

<b>PT #</b>	<b>DESCRIPTION</b>	<b>PG #</b>	<b>PT #</b>	<b>DESCRIPTION</b>	<b>PG #</b>
1166	HOSE	130	1405	HOSE	110
1167	CLAMP	130	1406	HOSE	110
1168	PUMP	130	1407	HOSE	110
1169	FILTER ELEMENT	130	1408	HOSE	110
1172	FITTING	130	1409	HOSE	110
1175	CAP	118	1410	HOSE	110
1176	MUFFLER	118	1411	HOSE	110
1177	BREATHER	120	1412	HOSE	110
1178	CAP	120	1413	HOSE	110
1179	PLUG	120	1414	HOSE	110
1185	BUSHING	96	1415	HOSE	110
1185	BUSHING	98	1416	FILTER	110
1185	BUSHING	104	1417	HOSE	110
1185	BUSHING	106	1418	HOSE	114
1185	PLUG	130	1419	HOSE	114
1193	FUSE	134	1420	HOSE	114
1203	CLAMP	130	1421	HOSE	114
1204	VALVE	130	1422	HOSE	114
1260	CLAMP	118	1423	HOSE	114
1266	END PLATE	104	1426	HOSE	114
1287	MANIFOLD	108	1427	HOSE	114
1291	VALVE	108	1428	HOSE	114
1293	MANIFOLD	107	1429	HOSE	114
1295	VALVE	107	1430	HOSE	114
1299	GUIDE	118	1431	HOSE	114
1320	TEE	116	1501	NUT	92
1323	TEE	116	1501	NUT	94
1324	ADAPTOR	116	1501	NUT	96
1364	PLUG	116	1501	NUT	106
1371	FITTING	130	1501	NUT	126
1372	ADAPTER	130	1501	NUT	142
1373	FITTING	130	1502	NUT	90
1374	FITTING	130	1502	NUT	92
1375	TUBE	130	1502	NUT	100
1376	CLAMP	130	1502	NUT	106
1377	FLOAT	130	1502	NUT	120
1378	SCREEN	120	1502	NUT	124
1387	ACTUATOR	118	1503	NUT	90
1388	CABLE	118	1503	NUT	92
1390	FILTER	118	1503	NUT	94
1391	FILTER	118	1503	NUT	96
1401	HOSE	110	1503	NUT	104
1402	HOSE	110	1503	NUT	106
1403	HOSE	110	1503	NUT	122
1404	HOSE	110	1503	NUT	126

<b>PT #</b>	<b>DESCRIPTION</b>	<b>PG #</b>	<b>PT #</b>	<b>DESCRIPTION</b>	<b>PG #</b>
1505	NUT	90	1537	BOLT	104
1505	NUT	100	1537	BOLT	106
1505	NUT	102	1537	BOLT	126
1505	NUT	104	1539	BOLT	100
1505	NUT	120	1540	BOLT	102
1505	CHAIN ASSM.	122	1540	SLIDE	122
1505	NUT	128	1541	BOLT	126
1505	NUT	142	1545	BOLT	104
1506	NUT	100	1545	BOLT	118
1506	NUT	102	1545	BOLT	120
1506	COVER	122	1545	BOLT	128
1507	NUT	90	1546	BOLT	90
1507	NUT	100	1546	BOLT	102
1508	NUT	100	1546	BOLT	104
1508	NUT	106	1546	BOLT	142
1520	WASHER	92	1547	BOLT	120
1520	WASHER	94	1549	BOLT	102
1520	WASHER	96	1551	MOTOR	122
1520	WASHER	142	1553	BOLT	100
1521	WASHER	92	1556	BOLT	100
1521	WASHER	106	1558	BOLT	96
1521	WASHER	120	1559	BOLT	92
1521	WASHER	124	1559	BOLT	100
1522	WASHER	92	1560	BOLT	96
1524	WASHER	118	1560	BOLT	100
1524	WASHER	120	1561	BOLT	100
1525	WASHER	102	1562	BOLT	106
1526	WASHER	100	1572	BOLT	90
1526	WASHER	102	1573	BOLT	90
1526	WASHER	120	1575	BOLT	106
1527	WASHER	104	1577	BOLT	122
1527	WASHER	106	1579	BOLT	92
1530	BOLT	96	1579	BOLT	94
1530	BOLT	106	1579	BOLT	96
1531	BOLT	126	1581	WASHER	100
1531	BOLT	142	1583	NUT	96
1533	BOLT	122	1591	SCREW	90
1534	BOLT	90	1604	COTTER PIN	98
1534	BOLT	100	1604	COTTER PIN	104
1534	BOLT	106	1604	COTTER PIN	128
1535	BOLT	90	1621	PIN	98
1535	BOLT	120	1630	CAPSCREW	104
1535	BOLT	124	1630	CAPSCREW	106
1537	BOLT	90	1639	NUT	104
1537	BOLT	102	1639	NUT	106



<b>PT #</b>	<b>DESCRIPTION</b>	<b>PG #</b>	<b>PT #</b>	<b>DESCRIPTION</b>	<b>PG #</b>
1640	NUT	90	1822	WASHER	100
1640	NUT	100	1822	WASHER	102
1640	NUT	106	1822	WASHER	104
1642	NUT	100	1822	WASHER	106
1669	WASHER	104	1824	ELBOW	112
1670	WASHER	90	1825	CONNECTOR	112
1670	WASHER	100	1825	CONNECTOR	116
1670	WASHER	102	1826	CONNECTOR	112
1670	WASHER	104	1828	ELBOW	116
1670	WASHER	106	1834	ELBOW	116
1671	WASHER	104	1836	CONNECTOR	112
1671	GUIDE	122	1839	RESTRICTOR	107
1684	SWITCH	138	1839	RESTRICTOR	108
1685	SWITCH	138	1843	BOLT	90
1686	SWITCH	138	1843	BOLT	92
1689	PLUG	138	1843	BOLT	94
1691	LIGHT	138	1843	BOLT	104
1711	BOLT	124	1905	CLEARANCE LIGHT	94
1713	BOLT	124	1906	GROMMET	94
1730	BOLT	90	1907	ID BAR	94
1740	NUT	90	1908	LICENSE PLATE LIGHT	94
1750	INSERT	92	1909	BRAKE LIGHT	94
1750	INSERT	94	1910	TURN SIGNAL LIGHT	94
1781	BOLT	104	1911	BACKUP LIGHT	94
1782	BOLT	98	1912	GROMMET	94
1782	BOLT	128	1915	WORK LIGHT	94
1802	UNION	112	1916	STROBE	92
1803	ELBOW	112	1916	STROBE	94
1804	ELBOW	112	1946	RELAY	134
1807	CROSS	112	1947	RELAY	134
1809	ADAPTOR	112	1949	BREAKER	134
1811	ELBOW	116	1955	COOLER	112
1812	ELBOW	112	1989	VALVE	107
1812	CONNECTOR	116	1990	FLOAT VALVE	107
1813	ADAPTOR	116	1993	VALVE	108
1815	SWIVEL	112	1994	CHECK VALVE	108
1815	TEE	116	2000	RELIEF VALVE	107
1816	CONNECTOR	112	2000	RELIEF VALVE	108
1817	CONNECTOR	112	2001	VALVE	107
1819	NIPPLE	112	2010	CHECK VALVE	108
1819	NIPPLE	116	2030	RESTRICTOR	116
1820	ELBOW	112	2041	FUSE HOLDER	134
1820	ADAPTOR	116	2042	FUSE	134
1822	WASHER	90	3203	PUMP	112
1822	WASHER	94	3203	PUMP	114

<b>PT #</b>	<b>DESCRIPTION</b>	<b>PG #</b>	<b>PT #</b>	<b>DESCRIPTION</b>	<b>PG #</b>
3203	PUMP	118	41503	DOOR	94
3212	LONG MANDRELL SHAFT	104	41602	REAR CANOPY	94
3230	HYDRAULIC MOTOR	102	41612	LH REAR DOOR	94
3230	HYDRAULIC MOTOR	104	41614	RH REAR DOOR	94
3230	MOTOR	110	41710	HOLD DOWN	124
3230	MOTOR	114	41726	RUBBER	126
3230	NUT	122	41728	ANGLE	126
3232	PUMP	120	41738	SPACER	126
3232	VALVE	130	41740	PLATE	126
41201	GB MOUNT LH	100	41744	END STRAP	124
41203	GB PIVOT LH	100	41764	SHAFT	128
41205	LINKAGE MOUNT LH	100	41766	ARM	128
41207	MOTOR BRACKET LH	102	41768	SHAFT MOUNT	128
41209	DRIVE HUB	102	41770	STRAP	128
41211	PIN	100	41771	REST TUBE	90
41213	PIN	100	41772	BOTTOM RUBBER	124
41215	SPRING BELL CRANK	100	41776	SEAL	124
41217	LINK	100	42001-B	MAIN FRAME	90
41221	LINK	100	42060	REAR SKIRT	90
41227	32" PLATE	102	42065	WATER VALVE	90
41229	ADJUSTMENT LINK	100	42067	DIRT DEFLECTOR RUBBER	106
41314	GB MOUNT RH	100	42073	SKIRT	90
41316	LINKAGE MOUNT RH	100	42075	BASE STRIP	90
41318	MOTOR BRACKET RH	102	42077	BRG. INSPECTION COVER	90
41322	GB PIVOT RH	100	42081	WATER VALVE LEVER	94
41401	PIN	106	42083	WATER VALVE ROD	90
41405	LIFT BELL CRANK LH	104	42085	SAFETY PROP.	90
41407	LIFT BELL CRANK RH	104	42101	CENTER DRAG RUBBER	90
41409	MAIN BROOM LIFT ARM LH	104	42103	CENTER DRAG SUPPORT	90
41411	MAIN BROOM LIFT ARM RH	104	42107	LIMB GUARD	92
41413	MAIN BROOM ROCK SHAFT	104	42107	LIMB GUARD	94
41415	PRES. CONTROL ROCK SHAFT	106	42121	MUD FLAP	90
41417	PIN	104	42130	SAFETY MOUNT	98
41421	MAIN BROOM LIFT STRAP	104	42131	SAFETY	98
41423	PRES. CONTROL ARM LH	106	42132	HOPPER SAFETY MOUNT	98
41425	PRES. CONTROL ARM RH	106	42146	CENTER DRAG RUBBER	90
41427	MAIN BROOM LIFT CHAIN	104	42147	CENTER DRAG RUBBER	90
41429	DRAG LINK	106	42201	SPRAY BAR	130
41431	BACKING	106	42203	SPRAY BAR	130
41433	DRAG SHOE MOUNT LH	106	42205	FILTER HOUSING	130
41435	DRAG SHOE MOUNT RH	106	42214	FILL RELIEF	90
41437	DRAG SHOE LIFT CHAIN	104	42220	WATER TANK MOUNT	90
41441	PIN	128	42303	TANK	114
41501	FRONT CANOPY	92	42303	TANK	120
41503	DOOR	92	42305	COVER	120

<b>PT #</b>	<b>DESCRIPTION</b>	<b>PG #</b>	<b>PT #</b>	<b>DESCRIPTION</b>	<b>PG #</b>
42310	TIE STRAP	120	43127	BOLT	122
42311	MOUNTING PLATE	120	43129	ELEV. CENTERING BUSHING	90
42402	ENGINE FRAME	120	43131	EXTENSION	124
42404	MOUNT	118	43134	BOLT	122
42501	PLATE	142	43135	BOLT	122
42502	POST	142	61401	MAIN BROOM LIFT ARM LH	104
42503	MOUNT	142	62505	BOX	138
42506	PLATE	142	62506	PANEL	138
42507	PROX. MOUNT	90	62510	HARNESS	139
42510	POST	142	62511	HARNESS	136
42517	HARNESS	135	62512	AUX. BOX	120
42517	HARNESS	141	62512	HARNESS	133
42527	CONTROL BOX	118	62812	CENTER PIN	98
42531	DECAL	138	62813	WASHER	98
42542	HARNESS	140	62813	WASHER	104
42801	LOWER SCISSOR, ROLLER	98	62813	WASHER	128
42803	LOWER SCISSOR, ANCHOR	98	62907	ACCESS DOOR	96
42805	UPPER SCISSOR, ROLLER	98	80126	MAIN BROOM COUPLER	104
42807	UPPER SCISSOR, ANCHOR	98	80128	BOLT	122
42809	SCISSOR PIN	98	1087-3	PROX. SWITCH	90
42813	SCISSOR ROLLER	98	3213-4	SHORT MANDRELL SHAFT	104
42815	LOWER SCISSOR, ANCHOR	98	42220-06	WATER TANK STRAP	90
42817	LOWER SCISSOR, ANCHOR	98			
42819	UPPER SCISSOR, ANCHOR	98			
42821	UPPER SCISSOR, ANCHOR	98			
42901	HOPPER	96			
42905	DOOR LINK	96			
42907	HOPPER DOOR	96			
42909	PIN	96			
42913	WINDOW	96			
42915	RUBBER FLASHING	96			
42917	UPRIGHT FLASHING	96			
43001	HOPPER LIFT FRAME	98			
43103	FRAME	122			
43103	FRAME	128			
43105	BOTTOM LINER	124			
43107	GUARD	122			
43109	SHAFT	126			
43111	TOP LINER	124			
43113	SHAFT	122			
43113	SHAFT	126			
43115	SPACER	122			
43121	CANOPY	124			
43123	ANGLE	122			
43125	BEARING	122			