

SA
STEWART-AMOS
Sweeper Co.

Owner's Manual



GALAXY R-4 Sweeper

Sweeper and Customer Information

Customer _____ Contact _____

Shipping Address _____ Mail Address _____

Phone Number _____ Fax Number _____

Email _____ Website _____

Sweeper Model _____ Sweeper Serial # _____

Chassis Brand/Model _____ Chassis Serial # _____

Auxiliary Engine Brand/Model _____ Auxiliary Engine Serial # _____

Curb Broom Motor Brand/Model _____ Curb Broom Motor Serial # _____

Water System Pump Brand/Model _____ Water System Pump Serial # _____

(Optional) Tool Box? _____ Safety Items Included _____

Special Information _____

Sold and Serviced by _____
Date Delivered _____

Sweeper and Customer Information

Customer _____ Contact _____

Shipping Address _____ Mail Address _____

Phone Number _____ Fax Number _____

Email _____ Website _____

Sweeper Model _____ Sweeper Serial # _____

Chassis Brand/Model _____ Chassis Serial # _____

Auxiliary Engine Brand/Model _____ Auxiliary Engine Serial # _____

Curb Broom Motor Brand/Model _____ Curb Broom Motor Serial # _____

Water System Pump Brand/Model _____ Water System Pump Serial # _____

(Optional) Tool Box? _____ Safety Items Included _____

Special Information _____

Sold and Serviced by _____

Date Delivered _____

Contents

I. WARRANTY INFORMATION	1
II. CUSTOMER ASSISTANCE	2
III. SYSTEM DESCRIPTION	4
A. Auxiliary Engine Shroud	6
B. Curb Broom	7
C. Hopper	8
D. Hydraulic System	9
E. Lights, Flashers, Alarm	10
F. Spray Bar	11
G. Sweeping Hood	12
H. Water System	13
I. Dual Steering	14
J. Hand Hose	15
IV. SWEEPER STARTUP PROCEDURES AND OPERATION	16
A. Control Panel	17
B. Throttle Lever	18
C. Auxiliary Engine Control System	19
D. Sweeping	20
E. Sweeping Condition Control	21
F. Curb Broom Operation	22
G. Dust Suppression System	23
H. Shutting Down the Sweeper	24
I. Dumping the Hopper	25
J. Dual Steering Operation	26
K. 12-Volt Backup System	27
K. Rapid Reference Operating Outline	28
L. Recommended Operating Equipment	29
V. GENERAL SAFETY GUIDELINES	30
A. Safety Alert Symbols	31
B. Chassis Driver Safety Instructions	32
C. Operator Safety Instructions	33
D. Maintenance Safety Instructions	37
VI. GENERAL SWEEPER MAINTENANCE CHECKS	40
A. Lubrication Maintenance Schedule	41
B. Periodic Maintenance Schedules	41
B1. Daily Maintenance (Every 8 Hours of Operation)	42

B2. Weekly Maintenance (Every 40 Hours of Operation).....	43
C. Component Maintenance Procedures	44
C1. Procedures For Clearing Obstructions From the Inlet Tube	44
C2. Cleaning Maintenance	45
C2a. Cleaning Procedures	45
C3. Storage Maintenance	46
C4. Auxiliary Engine Maintenance	46
C4a. Maintaining the Caterpillar/Perkins Fuel Filter	47
C4b. Fuel System Air Purge	48
C4c. Auxiliary Engine Replacement	49
C4d. Auxiliary Engine Stub Shaft Replacement	51
C5. Bolt Check Maintenance.....	53
C6. Curb Broom Maintenance	54
C6a. Disc Adjustment.....	54
C6b. Cylinder Rod End Adjustment.....	56
C6c. Bristle Replacement	57
C6d. Directional Valve Check	57
C6e. Hydraulic System Servicing	58
C6f. Hydraulic Pump Pressure Check	60
C6g. Hydraulic Adjustment	62
C7. Drive Train Maintenance.....	63
C7a. Drive Belt Tension Adjustment	63
C7b. Drive Belt Replacement.....	65
C8. Fan Housing Maintenance.....	66
C8a. Fan Housing Inspection.....	66
C8a. Fan Replacement.....	67
C8c. Fan Housing Liner Maintenance	70
C8d. Fan Shaft Bearing Maintenance	71
C9. Seal Maintenance	76
C10. Sweeper Engine/Fan RPM Check.....	77
C11. Sweeper Fluid Maintenance	78
C11a. Auxiliary Engine Cooling System.....	78
C11b. Auxiliary Engine Oil	78
C11c. Hydraulic System.....	78
C12. Sweeper Filter Maintenance	79
C12a. Auxiliary Engine Filters	79
C12b. Hydraulic System Filters	80
C13. Sweeping Hood Maintenance	82
C13a. Sweeping Hood Tension Spring Adjustment	82

C13b. Worn Flaps.....	83
C13c. Replacing the Flaps	83
C13d. Sweeping Hood Removal	83
C13e. Reinstalling the Sweeping Hood.....	84
C13f. Skid Plate Adjustment and Replacement.....	84
C14. Water System Maintenance.....	86
C14a. Water Pump.....	86
C14b. Water Filter Cleaning	87
C14c. Water System Winterization.....	87
D. Suggested Spare Parts List	88
VII. TROUBLESHOOTING.....	89
A. Miscellaneous	90
1. Unusual Noise or Vibration	90
2. Loss of Vacuum Power or Sweeper Not Picking Up.....	90
B. Sweeping Hood	91
1. Hood Not Gliding Properly – Excessive Runner Wear	91
2. Hood Drifting Down	91
C. Curb Broom	92
1. Broom Disc Spins Too Slowly	92
2. Broom Disc Spins Too Fast	92
3. Debris Trails Between the Broom Disc & the Side of the Sweeping Hood	92
4. Broom Disc Stalls in Heavy Debris	92
5. Broom Flings Debris Back Into Curb	92
6. Broom Flings Debris Across the Street	92
7. Broom Spins But Will Not Extend/Retract	93
8. Broom Operates But Will Not Lift	93
9. Broom Spins But Will Not Lower	93
10. Broom Raises But Leaks Down Immediately.....	93
11. Broom Drops But Will Not Otherwise Operate.....	93
12. Broom Will Not Drop or Otherwise Operate.....	94
D. Hydraulic System	95
1. Extreme Heat, Unusual Noise, or Poor Performance From the Pump	95
2. Hydraulic System Will not Operate	95
E. Water System.....	96
1. No Water Exiting Pump	96
2. Spray Nozzle not Working.....	96
3. Low Pressure	91

Appendix	97
A. Torque Reference Charts	98
1. English Bolt Torque Specifications	98
2. Metric Bolt Torque Specifications	98
3. Torque For Tightening Set Screws	99
4. General Conversion Table For Torque Units	99
5. Torque For Tightening Locking Collars	100
Notes	101–104
Parts, Hydraulic and Electrical Schematics and Information	105

I. Warranty Information

Stewart-Amos is committed to making our customers part of our friends and family. Our Warranty Department will handle all your warranty claims in a professional and prompt manner.

Prior to returning any warranted parts for a credit, you must contact our Warranty Department for an authorization. You may contact us at:

Call: 717.564.5600

Fax: 717.901.2309

E-mail: warranty@stewart-amos.com

Office Hours: Monday through Friday, 8 AM – 5 PM (Eastern Time Zone).

PLEASE NOTE: After you have received warranty authorization, the defective part must be returned to us. This is to ensure correct parts shipping and correct account crediting.

When you receive your shipment, please examine it immediately. Note any damages or shortages on your freight bill or receipt before accepting the part(s) from the carrier. Then, advise us immediately about what has occurred so we can expedite the parts you need as soon as possible.

Stewart-Amos Sweeper Co. uses balanced and matched system components for all curb brooms, suction heads and other components. These parts have been made and tested to our specifications. Any non-genuine, or “will fit,” parts do not always meet these specifications. The use of non-OEM parts can reduce the sweeper’s performance, void the sweeper warranties and present a safety hazard. In order to maximize the economy and safety of your sweeper, it is important that you use genuine Stewart-Amos Sweepers’ parts.

If you have any questions regarding the service or operation of your sweeper after you have reviewed this Manual, please feel free to contact us so we can provide you with additional instruction.

Our goal is to keep our customers 100% satisfied. We consider you a part of our Stewart-Amos family, and encourage you to contact us with any suggestions or comments.

II. Customer Assistance

Stewart-Amos is committed to 100% customer satisfaction. Our employees are trained to provide fast and dependable service to our valued customers, who we consider our friends and family. Our headquarters are located in Harrisburg, Pennsylvania, where we have a state-of-the-art manufacturing and production facility. This facility includes a department that is designed for complete servicing and refurbishing of sweepers.

Our contact information is:

Stewart-Amos Sweeper Company

Paxton At 27 Street

Harrisburg, PA 17101

Direct: 717.564.5600

Toll Free: 800.482.2302

Fax: 717.901.2309

Email: info@stewart-amos.com

Parts and Service Ordering and Information:

Call Toll Free: 800.482.2302

Office Hours: Monday through Friday, 7 AM – 5 PM (Eastern Time Zone).

To Order Parts via Fax:

Call: 717.901.2326

Available 24 hours per day, 7 days per week.

To Order Parts via Email Send Message to:

parts@stewart-amos.com

Available 24 hours per day, 7 days per week

To assure prompt delivery and processing of your order, you will need to have the following information available before contacting us:

- 1) Locate the **“Sweeper and Customer Information”** sheet at the front of this Manual. You will need to have the type and serial numbers for the power module engine, the chassis, and the sweeping unit.
- 2) The **part number(s), description(s) and the quantity needed.** We will also need to know if the part is for the right or left, front or back, and any other relevant information.
- 3) **Shipping information.** Orders are shipped by UPS unless otherwise specified. If your part(s) exceed the weight restrictions for UPS delivery, then a freight trucking company will be used for shipment. We will need to know how you want your order shipped; next day air, second day air, trucking company, cheapest possible, etc.

Our parts representatives make every effort to ship all in-stock parts the same business day if the order is placed before 12:00 noon, Eastern Time. For any order received after noon we will still make every effort to ship the same day. However, if this is not possible the order will be shipped the following business day.

III. General Sweeper System Description

As an owner or operator of a **Stewart-Amos Galaxy Series Sweeper**, you will need a basic understanding of the sweeping system. This section is designed to help you understand the system without being too technical.

The Galaxy Series uses a “closed loop” and/or regenerative airflow system, which is contained inside a sweeping hood (also sometimes termed a ‘sweeping head’), in order to vacuum up debris. To increase the sweeper’s vacuum power, a portion of the system’s air may be vented out of the system as exhaust air. The remaining air is recirculated in the system, which produces a blasting force of air under the sweeping hood.

To maintain the high velocity of air contained within the sweeping hood, metal skid pads on the sides, as well as flexible rubber flaps called “curtains,” are bolted on the front and back of the sweeping hood.

Power for the sweeper unit comes from the auxiliary engine, which is mounted on the sweeper frame behind the truck cab. The truck’s main fuel tank also supplies fuel to the auxiliary engine. Power to the sweeper is provided by the engine, which propels a fan by way of a drive-belt that is connected to a bearing-mounted drive shaft.

The fan, which is balanced and abrasion-resistant, draws air from inside the hopper and forces it out of the opening in the fan housing. A replaceable rubber liner is installed in the fan housing to prevent excessive wear.

THE SWEEPING PROCESS:

1. The fan, located outside the hopper, forces air drawn from the hopper down the pressure hose, and into the upper/rear pressure chamber of the sweeping head. This air is then funneled across the front of the chamber, and out a slot called the 'blast orifice.' As the air is pushed through the blast orifice, it is transformed into a high velocity airstream that is channeled forward and downward onto the sweeping surface in the sweeping head's lower/front chamber
2. The effect of this air blast is to both loosen the debris and lift it up off the pavement surface.
3. The debris is then transported across to the outflow (suction inlet) side of the sweeping hood. Flexible rubber flaps, called 'curtains,' are bolted to the front and back of the sweeping hood. These curtains, along with the metal skid plates on each end, contain the high air velocity within the sweeping hood.
4. The vacuum created by the fan pulls the debris up through the suction hose and into the hopper.
5. When the debris enters the hopper, a number of strategically placed water nozzles are used to decrease the amount of airborne dust. Once the debris and dust comes into contact with the water it becomes heavier and loses its speed, which causes the heavier objects to fall to the bottom of the hopper.
6. The air is then drawn through a screen in the top of the hopper where any remaining lighter objects are removed.
7. Any remaining fine particles of dust in the air stream are pulled through the screen and into the dust separator, which is located in the front of the hopper.
8. As a fan pulls the air from the dust separator, it creates a centrifugal force that throws the remaining fine dust against the walls of the separator.
9. The fan then draws the cleaned air from the dust separator back into the fan housing and the entire process begins again.

A. AUXILIARY ENGINE SHROUD



The optional auxiliary engine shroud contains two upward opening doors, one for each side of the power module. The shroud's upper door has struts to support the door when it is open.

The lower doors open downward and allow access to the hydraulic system components on the left side of the power module. All doors open independently of each other.

B. CURB BROOM



The sweeper's rotating hydraulic curb broom has been designed to loosen the debris from the ground and then direct it across and in front of the sweeping hood so it can be picked up.

The curb broom(s) is mounted under the chassis, in front of the sweeping hood. Curb brooms (also sometimes called 'gutter brooms') may be mounted on the left and/or right side of the sweeper. The curb broom is suspended from the frame on a hydraulically controlled arm that is operated using the switch(es) on the control panel inside the truck cab.

The hydraulic motor, which turns the broom's bristles, is mounted inside the disc that spins on the end of the arm. When the curb broom is not in use, it is hydraulically held and locked into the travel position up and off the pavement and under the truck. This travel position allows for minimum truck width and maximum ground clearance for travel at road speed.

C. HOPPER



The hopper is designed to hold the debris that has been collected by the sweeping hood. It is constructed of industrial-grade stainless steel.

The hopper is mounted to a heavy-duty frame that has been fastened to the truck's chassis, providing a stable base on which to mount the hydraulic cylinders. These cylinders are used to raise the hopper into a dump position.

An inspection door on each side of the hopper provides easy access for hopper clean-out after dumping. You will also find them useful for placing any objects that are too large for the sweeping hood into the hopper.

A full-width door has been installed on top of the hopper to provide easy access for cleaning the hopper's separator screens. There are two screen panels per unit. These may be cleaned by removing the two fasteners installed on each screen.

When the hopper is being dumped, both the dump door and the screen door will open and close automatically.

D. HYDRAULIC SYSTEM

Hydraulic fluid is pulled from the reservoir into the mechanically driven hydraulic pump that is mounted on the auxiliary engine. The pump passes the pressurized hydraulic fluid into the manifold, which is mounted on the left side of the power module. Valves attached to the side of the manifold are operated electrically

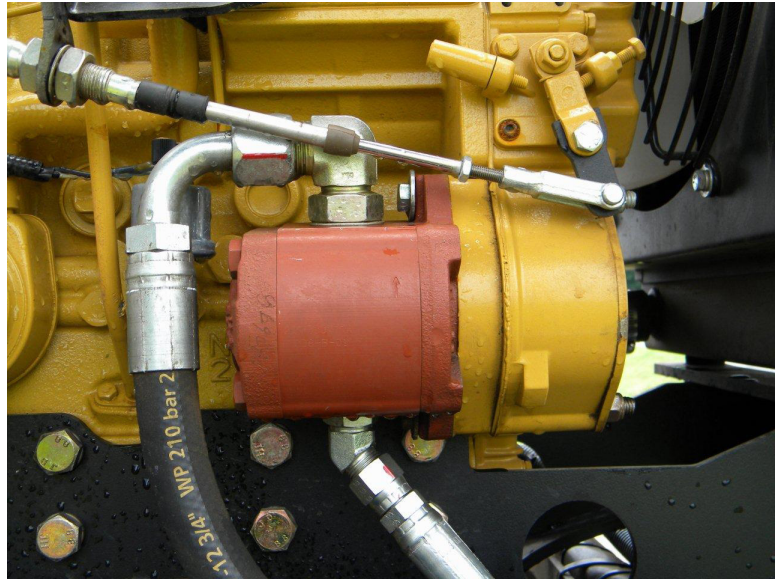

from the sweeper's in-cab control panel. These valves are used to channel fluid flow to the curb broom for broom operation, as well as to raise and lower the hood and hopper, and to power any other hydraulic functions.

OPTIONAL: A 12-volt auxiliary hydraulic pump, which is powered by the truck's 12-volt battery, enables the operator to control any hydraulic functions without running the sweeper's engine.



E. LIGHTS, FLASHERS, ALARM

The sweeper is equipped with a number of electric LED lights and flashers. Lights are standard for the broom(s) and the toolbox. These enable the driver/operator to see well when operating at night.

OPTIONAL: Lights illuminating the sweeping hood are also controlled by switches on the control panel.

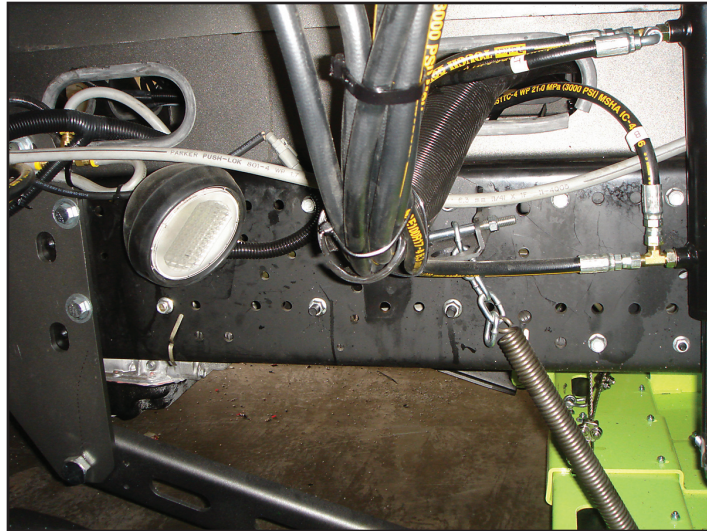

OPTIONAL: A backup warning alarm is optional. If installed, the high-pitched backup alarm warns bystanders that the sweeper is moving backwards and that they should stand clear.

OPTIONAL: A flashing barlight, strobe, or beacon light may be positioned on the top of the truck cab. These lights are used to alert pedestrians and motorists of the presence of the relatively slow moving sweeper machine. All lights are controlled via switches mounted on the control panel inside the truck cab.



F. SPRAY BAR

An optional spray bar is available. It is mounted to the front of the sweeper and provides additional dust suppression whenever the sweeper is being operated in extremely dusty conditions.

An electric water pump, which is powered by the truck's 12-volt system, supplies water to several nozzles. These nozzles are positioned along a pipe that is attached beneath the truck's front bumper.



G. SWEEPING HOOD

The central sweeping component of this air sweeper is the sweeping hood. The sweeping hood is mounted to the underside of the frame on both sides by a set of drag arms, tension springs and hydraulic lift cylinders.

A switch on the control panel operates the lift cylinders. The lift cylinders, along with the tension springs, control the vertical movement of the head.

The sweeping hood is connected to the fan housing and the hopper inlet tube by two large hoses. One hose is on the pressure (outflow) side while the other hose is on the vacuum (suction) side.

The pressure side hose is connected from the fan housing to the pressure inlet tube on the hood. The bottom of the vacuum hose is connected to the suction inlet tube on the hood, and the other end connects to the transition ring that seals against the hopper inlet tube when the hopper is in the lowered position. Both of these hoses are held in place by two metal band clamps, one at the top and the other at the bottom.

Details on the design and how it operates are included in the General Sweeper System Description. See pages 4 and 5..



H. WATER SYSTEM

It is necessary to control the amount of airborne dust within the sweeper's airflow system in order to avoid unnecessary wear of the fan, fan housing, hopper and sweeping hood.

This is accomplished by introducing a water spray at various locations on both the inside and outside of the sweeper.

The dust suppression system should be used whenever the sweeper is operated unless it is during wet weather conditions.

Here's how the dust suppression system works: Water is pumped out from the bottom left side of the sweeper's polyethylene water tank via an electric water pump. This has been



installed to force water out of the various spray nozzles that are located inside the hopper, around the sweeping hood and ahead of the curb broom (and optional right side curb broom).

Each spray nozzle produces a very fine mist that mixes with the dust and reduces the amount of abrasive airborne particles coming in contact with the sweeper components. Dual water pumps operate whenever a water function is enabled.

When water enters the sweeping hood it is drawn into the suction hose, where it continues to mix with the airborne dust. Once these water-laden dust particles enter the hopper they settle to the hopper floor.

The water tank fill opening is located on the right side of the power module.

By reducing the amount of abrasive airborne dust, the fan life is extended, as is the time between maintenance replacements of the fan housing liner. Use of the dust suppression system also reduces the amount of dust vented from the fan housing's exhaust.

I. DUAL STEERING

Dual steering is an option that allows the driver/operator of the sweeper to control the sweeper and chassis from the left or right hand side of the truck.

Major components relative to vehicle operation, (such as the steering wheel self-cancelling turn signals, the brake and accelerator pedal) are duplicated on both sides. Operating the sweeper from the right hand side gives the driver/operator better control while sweeping areas on the right side of the truck.



J. HAND HOSE

The hand hose is a valuable option that's designed to clean areas that are hard to get to, for example shallow catch basins, parking islands and fence edges. The areas that are otherwise inaccessible to the sweeping head. It is mounted to the side inspection door of the hopper and the inspection door can be moved to either side of the sweeper. The hand hose operates on fan-produced vacuum from within the hopper.



IV. SWEEPER STARTUP PROCEDURES AND OPERATION

The following sections briefly cover the operation procedures for the sweeper's main components. It is best to know and understand the sweeper before use. Read this entire section for information to help you get started.

Before attempting to operate this sweeper, it is important to read and understand all the instructions and control functions in this manual.

Also, read the information in the Truck Owner's Manual.

Always check the auxiliary engine's oil and coolant levels prior to the sweeper's first startup of the day. Follow the maintenance procedures outlined in Section VI, PERIODIC MAINTENANCE SCHEDULES, as well as the maintenance procedures required in the auxiliary engine manufacturer's Owner's Manual.

The following sections briefly outline the operational procedures for the Galaxy Series Sweeper's main components. Before actually operating the sweeper, please read this entire section.

A. CONTROL PANEL



The control panel is located inside the cab and mounted within easy reach of the driver. An hour meter, located under the auxiliary engine ignition, records the sweeper engine's running time. This gauge is important and should be checked periodically to detect any maintenance requirements.

On the top right of the control panel next to the hour meter and ignition is an optional gauge pack that includes an oil pressure gauge, tachometer, temperature gauge and volt meter. Sweeping operations are controlled from the in-cab control panel. Switches toggle differently depending upon what sweeper functions they control.

B. THROTTLE LEVER



The throttle lever is located on the left side of the control panel. To increase the throttle on the auxiliary engine, push the lever forward. To decrease the throttle, pull the lever down or toward you.

Tip: In order to conserve fuel and reduce noise, always use the lowest possible throttle position to accomplish a desired sweeping job.

C. AUXILIARY ENGINE CONTROL SYSTEM

Always check the auxiliary engine's oil and coolant levels prior to the sweeper's first startup of the day.

Look at the control panel to make certain that all switches are turned off. **Exception:** If the optional beacon/strobe light switches are preset to ON, the lights will automatically flash when the auxiliary engine ignition switch is turned to ON.

When the diesel engine is cold, it is necessary to preheat the engine with the glow plugs. Using the regular key switch, turn the key clockwise to the run position. The battery, glow plug and oil pressure indicator lamp should come on. When the glow plug indicator light goes off (2nd light down, the engine is ready to start). This step usually takes about 15 seconds.



Glow plug light on.



Glow plug light off.

The amount of time needed to preheat the engine is dependent on the engine's pre-start temperature. If the engine has been running within an hour of a restart, there may be enough residual heat remaining to make it unnecessary to use the glow plugs. If the engine has been turned off for only a few hours, then less warm-up time will be needed than when the engine is cold. Hard starting is usually an indication that the engine temperature has cooled enough to need preheating.

Start the engine with the throttle in the idle position. The sweeper is equipped with a safety shutdown system that will automatically shut the auxiliary engine off in the event of high coolant temperature or low oil pressure. Let the engine run for several minutes (until it warms up) before operating the sweeper.

D.SWEEPING

To begin sweeping, turn on all warning lights, strobe lights and beacons that will be used while sweeping. Start the auxiliary engine and set the throttle to the desired RPMs. Always use the lowest possible throttle position to accomplish a desired sweeping job. Turn 'ON' the switch(es) that correspond to the component(s) of the desired dust suppression.

During operation, the sweeper is typically driven between 1 and 15 mph, depending on maneuverability and the amount of debris to be picked up. Avoid sweeping over wood, large sticks and pieces of cardboard. These will clog the intake tube and may even cause damage to the intake hose.

When using the curb broom watch for large amounts of wire, which may become tangled in the broom. When you see these objects, stop, pick them up by hand and place them in the hopper through the side inspection doors.

DO NOT sweep too closely to a curb line or catch the hood runners in large holes. Catching a runner may twist, warp or otherwise damage the pickup hood, which is an expensive item to replace.

To raise the sweeping hood, press the top of the sweeping switch UP. The sweeping hood must be fully raised to provide maximum ground clearance before traveling. Always check to ensure the sweeping hood is completely raised prior to driving on a public roadway. Always turn 'OFF' the sweeper power switch before driving on the roadway, in order to prevent accidental engagement of the hood, brooms or other sweeping components.

E. SWEEPING CONDITION CONTROL

The sweeping condition control is the switch located on the bottom row of the control panel. This controls a damper, located inside the fan housing, which can be used to direct all the airflow down the pressure hose and into the sweeping hood. Alternatively, it will divert a portion of the airflow to an exhaust port located directly beneath the hopper.

When sweeping curbs and streets, the damper door should be in the 'heavy' (closed 100%) position. This will direct all of the airflow to the sweeping hood, which produces the maximum blast in the sweeping hood's pressure inlet.

When sweeping lightweight material, such as leaves, the damper door should be in the 'light' (open 100%) position. This decreases some of the volume of airflow through the

pressure inlet, reducing the air pressure applied against the rear of the front curtain. This allows debris to pass beneath the front curtain more easily.

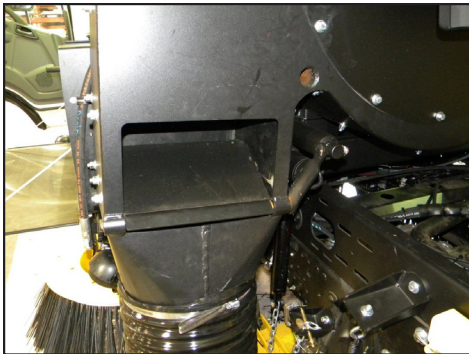

Air bleeder door shown 100% open.



Air bleeder door shown 100% closed.



To sweep both light and heavy material in one pass, open and close the air bleeder as you sweep. Through practice, it will not take long to become skilled in using this method to efficiently sweep various types of material.

F. CURB BROOM OPERATION

- To make the outside edge of the broom 'dig' harder into the curblines, press the broom tilt switch(es) UP.
- To reduce the broom tilt, press the broom tilt switch(es) DOWN.

To extend the life of curb broom's bristles, we recommend the broom be used only for sweeping curb lines.

When driving to-and-from job sites, or any time the curb broom is not in use, raise the curb broom to the stored position. Always keep the curb broom in this position when you are traveling, in order to provide maximum ground clearance for safe transport. Also, turn 'OFF' the power switch on the control panel to avoid accidental engagement of the hood, brooms or other sweeping components while transporting.



G. DUST SUPPRESSION SYSTEM

To use the dust suppression system, first turn on the auxiliary engine system by turning the switch on the control panel to 'ON.' Press the switch to 'ON,' which controls the water functions as desired. As conditions change, the water switches may be turned 'ON' and 'OFF.' The amount of time it takes to empty the water reservoir will depend on the number of switches in use and the length of time they are used.

When using a hydrant to fill the water reservoir, always allow the water to run for a short period of time before filling the reservoir. This will allow any sediment that may be trapped in the water line to flush out.



The sweeping hood and hopper

spray nozzles should always be 'ON' when sweeping, except during rainy conditions. The switch for the left/right curb broom(s)/dust suppression, as well as the switch for the sweeping hood, may be turned 'ON' and 'OFF' as needed.

Note: Using excess water to wet down leaves and other light debris tends to make them stick to the pavement. Sometimes neither the blast force nor the vacuum suction can remove such wet debris.



H. SHUTTING DOWN THE SWEEPER

When you are finished sweeping, use the following steps:

1. Set the engine throttle to idle.
2. If the curb brooms are in use, stop their operation and retract them into the travel position.
3. Raise the sweeping hood completely to provide maximum ground clearance.
4. Turn 'OFF' the dust suppression system.
5. The sweeper warning and flashing lights should be turned to the 'OFF' position.
6. Turn the sweeper's power switch to 'OFF'.

I. DUMPING THE HOPPER

The hopper should be dumped when it is full, or after sweeping has been finished for the day. Hopper dumping instructions are as follows:

1. Back the sweeper up to a dumpster, landfill or other suitable dumping area. ALWAYS dump on level ground and NEVER dump over an open pit or dock.
2. Before raising the hopper, check for overhead clearance restrictions.
3. Put the truck in 'PARK' and engage the emergency brake.
4. To raise the hopper:
 - Push dump switch UP; hold until hopper is raised completely.
5. If you plan to have the hopper raised for longer than the time needed to dump the debris, place the safety chocks on the dump cylinders. This also applies for when the hopper is being washed out or any other time you may have it in the raised position.
6. If the safety chocks were used, remove them and make certain the area under the hopper is clear.
7. To lower the hopper:
 - To lower the hopper, push the dump switch DOWN and continue holding down until hopper has lowered and slid completely forward.

J. DUAL STEERING

The dual steering components in the truck consist of integral, or a “cross shaft,” design.

This allows the driver/operator to operate the sweeper from the driver, or passenger side, of the vehicle. **The driver/operator should only drive from the passenger side at slow speeds and only while actually sweeping.**



(Integral steering shown in photo)

Warning! Drive/Travel from the left side only.

To operate the dual steering you must have the truck completely shut off then switch the toggle switch toward the desired operating side.



(Photo shown with the switch in left side operation mode. Press to the right for passenger-side operation mode. Make sure the chassis switch is completely off before doing the swap. Failure to do so could engage the check engine light.)

Integral Steering: Integral steering is set up to provide you the most ‘factory feel’ of operation. It has the ability to tilt and telescope the steering wheel for more comfort!

Cross Shaft Steering: Cross shaft steering has a shaft that goes in between the two steering columns. You will not be able to adjust the steering wheels in any way with this design.

K. 12-VOLT BACKUP SYSTEM

If your sweeper is equipped with the optional 12-volt back-up system follow these procedures for operating instructions.

1. Turn the console main power switch to the ON position.
2. Locate the switch on the bottom row that has '12-volt' labeled on it.
3. Press and hold this switch down while pressing the desired switch/function.
4. This 12-volt system is a true backup and will run all hydraulic operations.

Warning! Do not operate 12-volt pump for more than a minute; it is designed only to operate the system in case of a breakdown!



K. RAPID REFERENCE OPERATING OUTLINE

1. Check the truck engine and sweeper engine for the correct crankcase oil and coolant levels.
2. Fill the water storage tank.
3. Start the truck engine and check the control panel for the correct switch settings.
4. Crank the sweeper engine.
5. Let the engine warm-up to operating temperature before sweeping.
6. Turn on the water flow valves.
7. Turn 'ON' all warning lights and flashers.
8. Lower the sweeping hood to the pavement.
9. Throttle to desired sweeping RPMs.
10. Start the dust suppression system.
11. Turn on the curb broom if it is to be used.
12. Put the truck in gear and begin sweeping.
13. Avoid surface obstacles.

L. RECOMMENDED OPERATING EQUIPMENT

Whenever the sweeper is being operated it should be equipped with emergency equipment and hand tools. In the event of a breakdown or if you need to remove large debris, you will need safety devices. We recommend the following items, which may be adapted to suit your specific needs:

Shovel

Rake/Hoe

Heavy Push Broom

Gas Can

Tools/Toolbox

Flashlight

Safety Flares

Jumper Cables

Water Hose (to fill water tank)

Backpack Blower (oil/gas mix)

2-cycle Oil (for blower)

Quart of Oil

2-3 Cans of Tire Puncture Repair

Spare Tire

Fire Extinguisher

2-5 Ton Hydraulic Bottle Jack

V. General Safety Guidelines

Read and understand these Safety Sections before operating or servicing the sweeper. Learn how to stop the sweeper's engines suddenly in an emergency. Only persons who have read the Manuals and have been properly trained should operate the sweeper.

- Do not operate the sweeping unit without having the sweeping hood hoses in place.
- Remove the truck's ignition keys whenever working under the truck or sweeper.
- Open (turn off) the optional battery disconnect switch (located above the battery tray) when working on or near the auxiliary engine or its drive belts. This is to prevent an accidental starting or cranking of the auxiliary engine.
- Do not dump the hopper unless it is on level ground. When you dump, the truck must be in "PARK" and the emergency brake must be engaged. Do not try to dump the hopper over a dock or open pit.
- Whenever working under a raised hopper, make sure the safety chocks (provided with the unit) are in place at the dump cylinders.
- Whenever the hopper is lowered, beware of the area between the hopper and the frame. This is where a crushing injury may occur when either the hopper or the frame moves.
- Do not remove any of the belt guards, or work near drive belts while wearing any jewelry or loose clothing.
- To keep the engines in good condition, always use the proper tools for the job you are performing.
- Additional important safety guidelines are located in the Owner's Manuals for the chassis and sweeper engine.

Safety is of the utmost importance. Most accidents can be avoided by being aware of the conditions, the area and the equipment being operated. Always observe reasonable precautions and be a safe and careful operator.

A. SAFETY ALERT SYMBOLS

The Safety Alert Symbol, accompanied by a word, appears on the decals attached to your sweeper. **WHEN YOU SEE ONE OF THESE SYMBOLS IT MEANS THAT YOUR SAFETY IS INVOLVED! BE ALERT AND USE CAUTION! READ, UNDERSTAND AND FOLLOW ALL SAFETY MESSAGES.** You should always practice usual and customary safe working precautions in order to avoid serious injury or death. Also, use good common sense to avoid accidents and hazards.

The following one-word cautions used with the symbols are:

Caution! This is the lowest level of a safety message. It warns of possible injury and the signs are black and yellow.

Warning! These signs will warn you of a serious injury or possible death. These signs are black and orange.

Always maintain the safety decals in good, readable condition. If the decals are unreadable, damaged or missing, install replacement decals immediately. Contact Stewart-Amos Sweeper Co. for replacement of any decals needed.

All protective safety devices, guards and safety shields should be used and kept in good working condition. They should be inspected daily for any missing, worn or broken components. If any damage arises they must be replaced so they are in good working condition before the sweeper is operated. This must always be done to prevent the possibility of serious injury or death from thrown objects or entanglement.

Never remove, modify or cut any of the sweeper's protective shields and guards!

The sweeper **must** be equipped with a fire extinguisher, rated for all fires, located in an accessible and visible area. Never obstruct access to the fire extinguisher. It should be inspected routinely by a certified inspector for operational use, and replaced as needed.

B. CHASSIS DRIVER SAFETY INSTRUCTIONS

1. The sweeper operator must possess a valid motor vehicle license and meet any other requirements of the state in which the sweeper is operated. Contact your local State Department of Public Safety for any special licensing requirements needed to operate the sweeper in your area.
2. The operator of the sweeper must be trained and knowledgeable in the use and safety of this sweeper. This includes reading and completely understanding the Owner/Operator Manuals for the sweeper, the truck and the auxiliary engine. If the operator has any questions or does not fully understand information in any of the Manuals, contact the manufacturer of the equipment discussed in that Manual for a detailed explanation. Never allow an untrained or unqualified driver to operate the sweeper.
3. New operators should be trained in an open area, one that is clear of obstructions, prior to operating on public roadways.
4. **Never use drugs or alcohol** immediately before or while driving/operating the sweeper. Drugs and alcohol will affect the operator's alertness and coordination, which can affect their ability to operate the sweeper safely. Any operator using prescription or over-the-counter medication must consult a medical professional to determine any side effects of the medication that might reduce their ability to operate the sweeper safely. Never knowingly allow anyone to operate the sweeper when their alertness or coordination is impaired, as doing so could cause serious injury or death to the operator or others.
5. **Prolonged exposure to loud noise may cause permanent hearing loss!** Sweeper operation can be noisy enough to cause permanent hearing loss. We strongly recommend that operators always wear hearing protection when the noise in the cab exceeds 80 dB. Noise over 85 dB, when sustained over an extended amount of time, has been shown to cause hearing loss. Noise exceeding 90 dB over an extended amount of time will cause permanent or total hearing loss. Please note that hearing loss from loud noises from sweepers, radios, mowers, chain saws and other such sources close to the ear is cumulative over a lifetime with no hope of natural recovery.

C. OPERATOR SAFETY INSTRUCTIONS

THE SAFETY INSTRUCTIONS LISTED BELOW ARE INCLUDED IN ORDER TO PREVENT ACCIDENTS, SERIOUS INJURY, DISMEMBERMENT OR DEATH TO THE OPERATOR AND/OR ANY BYSTANDERS OR ANIMALS. READ AND UNDERSTAND THESE INSTRUCTIONS FULLY BEFORE OPERATING THE SWEEPER OR THE TRUCK.

1. **NEVER** attempt to get onto or off of the sweeper or truck while the machine is moving.
2. Start the truck engine and auxiliary engine only when the operator is seated in the truck's operator seat with the seat belt fastened. Read the truck and Auxiliary engine Owner/Operator's Manuals for proper starting instructions and operation.
3. Operate the sweeper controls only when you are properly seated with the seat belt fastened.
4. **DRIVE OR TRANSPORT THE SWEEPER ONLY AT SAFE SPEEDS.** Familiarize yourself with the driving characteristics of the truck and how it handles before operating or transporting on streets and highways. Serious accidents and injuries can result from driving this sweeper at unsafe speeds. Make sure the truck's steering, brakes and wheels are in good condition and that all components work properly. Before driving the sweeper, determine the safe speeds for the machine and operating conditions. Abide by the following rules:
 - Test the sweeper at a slow speed and increase the speed slowly. Apply the brakes smoothly to determine the stopping characteristics of the sweeper. Remember, as you increase the speed of the truck the stopping distance also increases. When driving on wet or rain-slicked roads and down hills, the braking distance also increases. Use extreme care in these situations and reduce your speed. **Never** operate the sweeper with weak or faulty brakes.
 - Obey all traffic laws and regulations. **Never** exceed the posted speed limit.
 - Please be aware that the sweeper has a high center of gravity. This factor may be further increased when the hopper and/or the water tank are full. Make sure extreme caution is used when driving at highway speeds. Slow down for sharp corners to avoid tipping or turning the sweeper over.

- Only drive the sweeper at speeds determined to be safe and that allow for proper control of the machine while driving and during an emergency.
5. Before starting into the sweeping operation, make sure that all warning signal lights are connected, visible and working. The sweeper's headlights, brake lights, backup lights and turn signals should be routinely inspected for correct functioning. Immediately repair any non-functioning light(s).
 6. **Use EXTREME CAUTION when operating the sweeper in traffic.** The sweeper is equipped with warning signals and flashing lights. Use these to alert motorists and pedestrians of the sweeper's presence and relatively slow speed.
 7. **DO NOT exceed the rated operating speed for the truck and auxiliary engines.** Sweep at a speed that allows safe operation and control of the sweeper. This will depend on the street condition and the type and amount of debris being collected. The normal speed range is between one and three miles per hour (mph). Slow down for parked cars, curbs, corners, protruding signs and any other obstacles. Use slow traveling speeds when you are operating on or near drop-offs, ditches, steep slopes, power lines, and any overhead obstructions, or when avoiding debris and foreign objects. Excessive operating speeds can cause engine and sweeper components to fail.
 8. **NEVER** reach outside of the truck cab window/door to pick up a foreign item or to clear obstacles such as a road sign or tree limb that is obstructing passage. Instead, stop the sweeper, shut down all sweeping components and wait for all the parts to come to a complete stop. Only then should the operator exit the cab to handle the obstacles.
 9. **DO NOT** raise the sweeper's broom components when bystanders are within 25 feet of the sweeper. Make sure that the curb brooms have come to a complete stop before raising them from the street surface. Raising the sweeping components exposes the rotating brooms, which creates a potentially serious hazard due to thrown objects or from direct broom contact.
 10. **DO NOT** operate the sweeper if the fan's exhaust (blast) hose is removed, damaged or improperly installed on the outlet tube or sweeper hood. The fan can throw objects, resulting in serious injury to the operator or bystanders.
 11. Any objects that could become entangled in a sweeping component, as well as any that could plug the suction tubes, **MUST** be removed from the pavement

or surrounding area prior to sweeping. Objects such as chains, rope, cable and wire could become entangled in the rotating parts of the sweeping component and cause mechanical damage as well as serious injury.

12. **KEEP AWAY FROM ROTATING CURB BROOMS** to prevent entanglement and possible serious injury or death. Be aware that rotating brooms can pull bystanders into the sweeper.
13. **KEEP AWAY FROM SUCTION COMPONENTS** such as the suction head and suction hoses. Air enters the fan housing with a great amount of force. Also use extra caution when the power is running and the hopper is raised.
DO NOT wear loose clothing or position yourself or others near the fan-housing inlet. This is necessary in order to prevent being drawn into the sweeper, which can cause serious injury or death. Keep any items that might be drawn into the sweeper hood (such as tools and replacement parts) clear of the sweeper before starting operation.
14. **NEVER ALLOW CHILDREN TO PLAY ON OR UNDER THE SWEEPER OR TO OPERATE THE SWEEPER'S CONTROLS.** Children can slip and/or fall off the sweeper or cause the sweeper components to shift, which can result in serious injury (crushing themselves or others) or death.
15. **AVOID** body contact with debris collected in the hopper. Always use protective clothing, including gloves and eye protection, when servicing or working in or around the hopper. Debris in the hopper can cut or puncture, so leather gloves are recommended when operator or others need to handle hopper debris.
16. **NEVER SWEEP INTO HOT OR BURNING DEBRIS.** A burning object, even something as small as a lit cigarette, could ignite the collected waste inside the hopper. This could possibly destroy the sweeper and inflict serious injury or death to the operator of the sweeper and/or bystanders.
17. **DO NOT ALLOW THE SWEEPER TO COME IN CONTACT WITH POTENTIALLY DANGEROUS AND/OR HAZARDOUS MATERIAL.** Hazards may include, but are not limited to, the following:
 - Cutting Hazards – Broken Glass, Lumber with Protruding Nails
 - Corrosive Materials – Batteries, Acids and Bases

- Fire Hazards – Fuel Spills, Burning Materials
- Chemical Hazards – Chemical Spills, Discarded Chemical Containers
- Biological Hazards – Decaying Carcasses, BioMedical Waste
- Carcinogenic Materials – Asbestos
- Radioactive Hazards – Radioactive Waste, Radioactive Material

These types of material usually require special handling to ensure safe collection and proper disposal. These items should not be collected by the sweeper, nor can they be



disposed of in a general landfill site like most sweeper-collected waste. Contact the appropriate authority for the collection and disposal requirements of any such dangerous and/or hazardous materials.

18. **ALWAYS** wear OSHA-approved and required personal protective equipment



when coming in contact with, and/or removing, potentially dangerous and hazardous material that has been collected by the sweeper or that is obstructing the sweeper components. Use extra caution with dangerous and hazardous material such as decaying carcasses, sharp objects, chemicals, etc.

19. **The sweeper operator should use EXTREME CAUTION when operating within 25 feet of a bystander.** Stop sweeping if anyone comes within 25 feet of the sweeper! Also use caution when sweeping dense objects such as gravel or broken glass. Objects may become dislodged and then propelled a distance of up to 25 feet.
20. **EXTREME CAUTION** should be used when backing up the sweeper. Make sure no bystanders, animals, signs, vehicles or buildings are in the sweeper's path. Ensure that the sweeper is not being backed into the path of vehicle or pedestrian traffic.
21. **ALWAYS CHECK** to make sure no bystanders or animals are within 25 feet of the sweeper when cleaning the hopper or dumping its contents. The hopper contents may exceed several thousand pounds and could fall on or crush a bystander or animal.

D. MAINTENANCE SAFETY INSTRUCTIONS

The safety instructions listed below are designed to prevent accidents, serious injury, dismemberment or death to the operator and/or any bystanders or animals. Read and understand these instructions fully before performing any maintenance on the sweeper or the truck.

1. Periodically inspect all of the moving parts for wear, and replace them as needed with authorized service parts. You will need to look for leaky or loose fasteners and fittings and worn or broken parts. Check to make sure all cotter pins and washers are in place. Maintain your sweeper in good working order to prevent serious injury.
2. Perform a walk-around inspection on the entire sweeper prior to each use. Accidents may occur, or damage could result to the sweeper, if it is not properly maintained and in good working order. Check the following:
 - Make sure that all safety shields and guards are in place and in good working condition.
 - Check the tires for tread wear and make sure the tire pressure is at the rated PSI.
 - Make sure all the fluid levels are full. Replenish if necessary.
 - Make sure the fuel, oil and coolant caps are on and tightened.
 - Check for any loose bolts, worn or broken parts, leaky or loose fittings, or pinched hydraulic hoses.
 - Make sure any replacements are the correct size and properly installed.
3. **DO NOT** approach or inspect the sweeper fans while they are rotating. Shut down the sweeper and wait for all rotating motion to stop completely before inspecting or performing maintenance.
4. **USE EXTREME CAUTION** when climbing onto the sweeper to perform repairs, maintenance or routine cleaning. Use all appropriate stands and ladders to access the areas that cannot be reached from the ground level.
5. Before performing any maintenance on the sweeper, stop both the truck and auxiliary engines. Place the transmission in park and set the parking brake.

After the engines have been turned off, remove the keys to prevent inadvertent or accidental starting.

6. **NEVER** operate the truck or auxiliary engine in a closed building or without adequate ventilation. The exhaust fumes can be hazardous and deadly to your health.
7. **NEVER** attempt to clean, adjust, repair, lubricate, remove obstructions or perform any type of service to the sweeper or its components while the sweeper is in motion and/or the truck and auxiliary engine is running. Completely shut down the sweeping components, the truck engine and the auxiliary engine and wait for all motion to come to a complete stop before servicing the sweeper.
8. **NEVER** remove the sweeper's exhaust hose (going to the sweeping hood) in order to perform repairs or maintenance while the sweeper is operating. Objects could be propelled from an open hose at a very high velocity, causing serious injury or death. Always turn off the sweeping components, the truck and auxiliary engines, and then wait for all motion to come to a complete stop before servicing any sweeper component.
9. **NEVER** crawl under the hopper bin while the hopper is in the raised position until the hopper has been secured with the safety prop in position. An accidental operation of a lifting lever or a hydraulic failure may cause a sudden drop of the unit.
10. **NEVER** come into contact with the hot surfaces on the bottom of the skid shoes. Use gloves and eye protection when inspecting or servicing hot components.
11. **ALWAYS** remove the negative battery cable from the battery, or turn off the battery disconnect switch, prior to performing maintenance on the electrical system. This must be done in order to prevent accidental circuit shorting and sparks, which can result in wiring damage, fire and/or personal injury.
12. Battery post terminals and related parts contain lead and lead compounds. These chemicals are known to the state of California to cause birth defects or other reproductive harm. **ALWAYS WEAR GLOVES DURING, OR WASH YOUR HANDS AFTER, HANDLING THEM.**

13. **NEVER** operate the sweeper with leaking hydraulic oil or fuel as this could present a hazard. **DO NOT CHECK FOR LEAKS WITH YOUR HANDS!** Use a heavy piece of paper or cardboard, or some other suitable object. High-pressure streams of oil coming from leaks or breaks in the line could penetrate the skin. If this happens, have the injury treated immediately by a physician who has knowledge and skill in this situation.
14. **NEVER** attempt to tighten a connection or repair a pump or hose while the system is pressurized. Always shut down the truck and auxiliary engines first, in order to relieve the hydraulic oil pressure, before performing any repairs to the hydraulic system.
15. **USE EXTREME CAUTION** when refueling the sweeper. Fuel is highly flammable and explosive, and can be dangerous if not handled safely. Follow the precautions listed below to reduce the danger involved in refueling:
 - Turn off the truck and auxiliary engines before refueling.
 - DO NOT refuel while smoking or near an open flame.
 - DO NOT store the sweeper, with fuel in the tank, in a building where fumes can reach an ignition source.
 - When filling the tank use a plastic funnel — without a metal screen or filter — in order to avoid fire or an explosion caused by static electric discharge.
 - DO NOT spill fuel, as it can damage plastic and painted surfaces. Clean up any spilled fuel immediately.

DO NOT MODIFY OR ALTER THIS SWEEPER. Do not allow anyone to modify or alter this sweeper, its components, or any of its sweeper functions.

VI. General Sweeper Maintenance Checks

This information is to be used in combination with your truck chassis and auxiliary engine Owner's Manuals. You will need to refer to each manual for specifics on maintenance schedules and procedures for this unit.

When you are using the sweeper on a daily basis you will need to do a walk around inspection prior to each operation. One of the best times to do this is when you are filling the water tank or whenever the hopper is raised. Here are examples of what to look for:

1. Are any of the belts loose or frayed?
2. Do all the seals look tight? Are the dump and side doors tight?
3. What condition are the fan and suction seals in?
4. Check all the fluid levels and replenish as necessary.
5. Look at the air filter's air restriction indicator. It is located on or near the auxiliary engine's air filter canister. Has the 'need to service' window changed colors? If it has changed, then change the air filter.
6. Inspect the curb brooms for bristle wear and any leaking hydraulic oil on the hoses or fittings.
7. Are the curtains or flaps properly adjusted? Do they need replacing?
8. Is the sweeping hood rested properly on the ground?
9. Are all the safety shields and guards in place and in good working condition?
10. Check for any loose bolts, worn or broken parts, leaky or loose fittings, or pinched hydraulic hoses.

Performing any needed repair of the sweeper components prior to traveling to the sweeping location saves time and is much easier when you have the proper tools available.

A. LUBRICATION MAINTENANCE SCHEDULE

ITEM	FREQUENCY	LUBRICANT
Truck chassis and engine	Refer to truck Owner's Manual	Refer to truck Owner's Manual
Change auxiliary engine oil & filters	Refer to auxiliary engine Owner's Manual	Refer to auxiliary engine Owner's Manual
Fan shaft bearings	Every 250 hours of operation	Grease with lithium-based grease, one pump from a hand-operated gun. DO NOT over-grease or use a power gun.
Curb broom arm joints	Every 120 hours of operation	Grease with a Lithium-based grease.
Fan and intake seals	As required	Lubricate with a rubber protectant, petroleum jelly or grease to prevent drying and loss of resilience.

B. PERIODIC MAINTENANCE SCHEDULES

The Daily and Weekly Maintenance Schedules list specific items and areas that need to be inspected. The items listed cover the main areas that must be checked; however, it is not a complete list.

The Daily and Weekly Maintenance Schedules have been designed so that you may make copies and keep a record of when the sweeper was inspected and by whom.

B1. DAILY MAINTENANCE (EVERY 8 HOURS OF OPERATION)

<p>WARNING: Remove chassis keys and/or disconnect the chassis battery cable when checking the fan housing liner or the fan.</p>		
<p>TRUCK Check the air filter. Replace as needed.</p>		<p>SWEEPER HOOD Check runners for wear and replace if worn 80% of the way through.</p>
<p>Check the engine oil and fill to proper level. Refer to Truck Owner's Manual for oil weight & frequency.</p>		<p>Check for holes, tears or uneven ground contact when the hood is down. Adjust chain length or replace.</p>
<p>Check the fan belts for wear and tension.</p>		<p>Check drag arm bolts for wear. If worn into bolt shoulder, replace with common grade of same size.</p>
<p>Check the tires for excessive wear or objects. Fill to the proper pressure.</p>		<p>Check intake & exhaust hoses for wear and replace if holes or tears are present.</p>
<p>Check the radiator coolant and fill to level. Check hoses for cracks.</p>		<p>HOPPER SCREEN Rinse out with water.</p>
<p>Fill the fuel tank as needed. Keep track of gallons used each day.</p>		<p>DRIVE BELT Check tension & wear. Tighten if deflection is greater than 1/2". Replace if worn.</p>
<p>Check transmission fluid with the engine running. Fill as needed.</p>		<p>FAN & INTAKE TUBE SEALS Check for wear & tears. Replace if they do not seal properly. Lubricate with petroleum jelly or equivalent.</p>
<p>AUXILIARY ENGINE Check oil level. Fill as needed. Refer to Auxiliary Engine Manual</p>		<p>CURB BROOM Fill hydraulic reservoir as needed. Adjust disc angles as needed to compensate for wear.</p>
<p>Check belt alignment, tension and wear.</p>		
<p>Check radiator coolant level. Refer to Auxiliary Engine Manual.</p>		
<p>Clean radiator cooling fans and frontal area as necessary.</p>		
<p>Check the air restriction indicator window Replace the filter's dry element if window shows 'need to service'. DO NOT BLOW OUT THE ELEMENT.</p>		
<p>WATER SYSTEM Flush 'Y' strainer with water and fill water reservoir. Inspect all water nozzles for proper operation. If not operating, disassemble & clean or replace filters.</p>		<p>INSPECTED BY: _____ DATE: _____</p>

B2. WEEKLY MAINTENANCE (EVERY 40 HOURS OF OPERATION)

WARNING: Remove the chassis keys, turn off optional safety disconnect, and/or disconnect the auxiliary engine's negative battery cable when checking the fan housing liner or the fan.

ITEM	MAINTENANCE	
FAN	Check for wear of the blades and replace if worn through.	
FAN HOUSING LINER	Check for wear and replace at first signs of holes.	
FAN HOUSING LINER BOLTS	Check the heads for wear and replace as needed.	
WATER SYSTEM	Drain the water reservoir. Remove and clean the screen inside the 'Y' strainer.	
INSPECTED BY: _____		
DATE: _____		

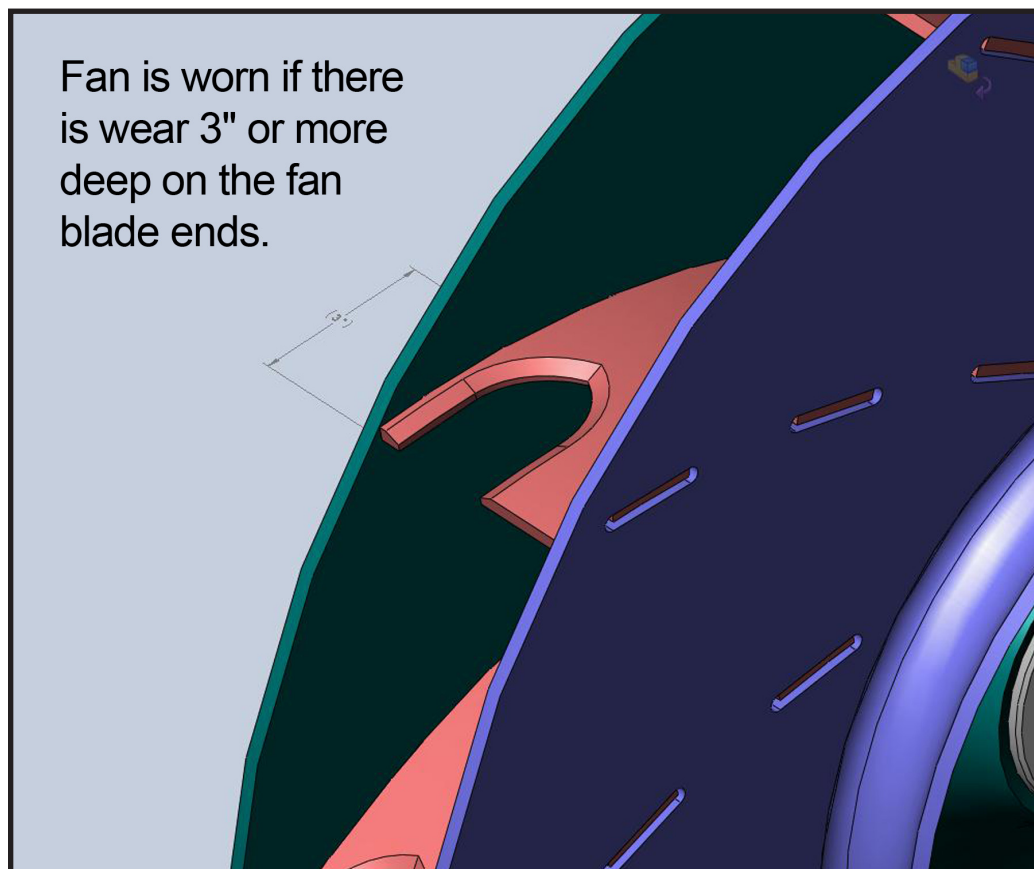

C. COMPONENT MAINTENANCE PROCEDURES

C1. CLEARING OBSTRUCTIONS FROM THE INLET TUBE

1. Locate the sweeper in an area conducive to safe work practice. **Make sure the sweeper is parked with the brakes set and that the engine is off.**
2. Remove all keys (chassis and console).
3. Remove the band clamp from the bottom end of the flexible intake tube, which is connected to the sweeping hood. Clear the tube of obstructions from the lower end.



CAUTION: Be extremely careful when cleaning the inlet tube, as sharp objects such as metal, glass, hypodermic needles, hazardous materials, etc., may be present. Be sure to wear appropriate protective equipment!

4. Reconnect the flexible intake tube and tighten the band clamp to the sweeping hood. Check for proper operation before continuing.

WARNING: Do not raise the hopper in an attempt to clear the obstruction from the top of the suction tube. Doing this can create a crushing injury between the hopper and the top of the suction tube.

C2. CLEANING MAINTENANCE

To keep your sweeper operating at its peak performance it is imperative that you clean it daily. Dirt and grime are much harder to remove once they have had a chance to build up and bond to surfaces. Daily debris collects and adheres rapidly, decreasing airflow, blocking water nozzles, and causing unnecessary wear. You will maximize the life of the components by cleaning the sweeper as often as possible.

C2a. Cleaning Procedures

1. Spray-wash the outside and the underside of the sweeper and truck cab. Be sure to remove rust-causing road grime.
2. Clean out the inside of the truck cab, removing any items not required during sweeping operations.
3. Clean windows and mirrors for maximum visibility.
4. Dump the hopper contents.
5. Open the side inspection doors and spray wash with the maximum water pressure available.
6. Raise the hopper for a final wash through the open doors. Pay special attention to corners and seams.
7. Wash the sweeping hood, inlet hoses and tube, both inside and out.
8. When you have completed the washing leave the hopper inspection doors to the inside open to let it dry as soon as possible.
9. If practical, leave the hopper raised and inch or two in order to relieve the pressure against the fan and intake seals. This allows the seals to regain their shapes and provides longer wear for them.

C3. STORAGE MAINTENANCE

The importance of proper storage and maintenance care cannot be over emphasized. Your sweeper is the core of your business and, with the proper care, it will provide the service needed. The day-to-day maintenance recommendations should be followed in order to correct any minor problems before they become costly repairs.

If you need to store the sweeper for any extended period of time it is recommended that you store it inside an enclosed building. Always raise the hopper an inch or two. This will relieve the pressure against the fan and intake seals allowing them to regain their shape. Open the inspection and dump doors.

The sweeper is designed to withstand exposure to the elements. If inside storage is not an option, a canvas cover for the entire sweeper can be used to protect rust-prone components, such as the sweeper engine muffler and the throttle linkage. When storing the sweeper outside leave the inspection and dump doors closed.

C4. AUXILIARY ENGINE MAINTENANCE

Your Stewart-Amos Galaxy Series sweeper is equipped with a four-cylinder, water-cooled diesel engine. The information in this section is intended to be used in conjunction with your auxiliary engine Owner's Manual. Be sure to read it for specifics on maintenance schedules and procedures required for this unit.



C4a. Maintaining the Caterpillar/Perkins Fuel Filter

The fuel filter on the Caterpillar/Perkins engine is inside a 'clamshell-type' canister located in-line between the fuel pump and the injector pump. The fuel filter is located on the passenger side of the auxiliary engine. When replacement is needed, use Stewart-Amos part number 50811 (Cat/Perkins part number 067-6987), or equivalent, and follow the instructions listed below:



1. Before unscrewing the fuel filter, make sure the sweeper power switch is in the 'OFF' position. If the switch is in the 'ON' position the electric fuel pump will be supplying fuel to the filter as you attempt to remove it.
2. Once the switch is in the 'OFF' position, unscrew the bolt at the **top** of the fuel filter canister. The bottom flange will now be removable.
3. Remove filter from the bottom; dispose of it properly. Reverse the process, inserting the new filter from the bottom, replace bottom cap, and rebolt from above.
4. The fuel filter head's bleeder bolt should then be loosened so that air may be removed from the canister. The bleeder bolt is located between the fuel supply line and the auxiliary engine.
5. Prior to restarting the engine, use the primer bulb located in-line to the left of the fuel filter. Pump bulb until a small amount of fuel comes from the bleeder bolt. Squeeze out just enough fuel to make sure there is no more air in the lines.
6. Re-tighten the bleeder bolt. The auxiliary engine is now ready to be started.

C4b. Fuel System Air Purge

Whenever the fuel supply system is opened, there is the possibility of air becoming trapped within its lines or components. For instance, this can occur if the fuel filter was changed without following the bleeding procedure instructions listed above. For example, if any attempt to start the auxiliary engine was made during the procedure, then any air in the fuel filter or fuel line would be pulled into the injector pump and injector lines. This air would prevent fuel from reaching the cylinders and the engine would not start. Any time air gets into the fuel lines between the fuel filter and the injectors, that air must be purged from those lines before the auxiliary engine will start.

1. Make sure you have followed the instructions above for bleeding the fuel filter canister before you continue to remove the air from within the fuel line between the fuel filter and the fuel injector pump.
2. Loosen the banjo fitting where the fuel line enters the injector pump.
3. Locate the primer bulb, located in-line to the left of the fuel filter. Pump bulb until a small amount of fuel comes from the banjo fitting. Squeeze out just enough fuel to make sure there is no more air in the lines.
4. When fuel begins to flow from around the banjo fitting, quit squeezing the primer bulb.
5. Re-tighten the banjo fitting.
6. Loosen the injector lines at the point where they enter the injectors.
7. To pump fuel from the injector pump to the injectors you will need to crank the engine several times.
8. When fuel begins to flow from the loosened lines, turn the auxiliary switch to the 'OFF' position.
9. Re-tighten the lines. The air should be removed from the fuel lines and the engine ready to start.

C4c. Auxiliary Engine Replacement

The sweeper's auxiliary engine is built to provide years of service when maintained properly. Following the maintenance guidelines and schedules will prolong the performance; however, it is still subject to wear. At some point in time, the auxiliary engine may require removal so that it may be serviced or replaced. Use the following guidelines for this procedure:

1. Remove the sweeper engine battery cable to prevent the engine from being accidentally started.
2. Tilt the cab forward to gain additional working area.
3. Remove the belt guard.
4. At this point, you are ready to disconnect the wires that prevent the removal of the engine from the mounting skid. Before disconnecting any of the wires, wrap a piece of masking tape on each wire. As you disconnect them, label each wire with a marker in the order that you disconnect them. This will simplify the re-connection process upon reassembly.
5. Unplug the engine harness and disconnect the starter cables.
6. Make sure that all the disconnected wires are tied or secured in order to prevent any of them catching as the engine is removed.
7. Disconnect the throttle cable and make sure it is clear from the engine.
8. Disconnect the fuel line. Bend the end back upon itself and tie it with wire or tie-wrap to prevent fuel from leaking.
9. Remove the two front engine leg mounting bolts that hold the front leg to the power module.
10. Remove the two, rear engine leg mounting bolts that hold the rear leg to the power module.

11. Use the jackscrews to push the engine toward the center of the truck, loosening the drive belt. DO NOT pry against the oil pan as it will crack the pan and void the warranty.
12. Remove the outside sets of jackscrew jam nuts and jackscrew nuts.
13. Remove the jackscrew nuts and threaded rods from the side of the engine legs.
14. Remove the fan drive belt from the engine pulley.
15. Disconnect the hydraulic hose from the engine-mounted pump. Secure the hoses so that the hydraulic fluid does not drain out.
16. If the sweeper is equipped with a tachometer or other devices, disconnect them from the engine at this point.
17. Use a hoist to slowly lift the engine out and away from the sweeper.
18. Transfer the engine legs and brackets to the replacement auxiliary engine.
19. To insert the replacement auxiliary engine, follow the steps 1 through 16 in reverse order.
20. Once you have finished with these steps, follow the procedures outline in 'DRIVE BELT ADJUSTMENT.'

C4d. Auxiliary Engine Stub Shaft Replacement

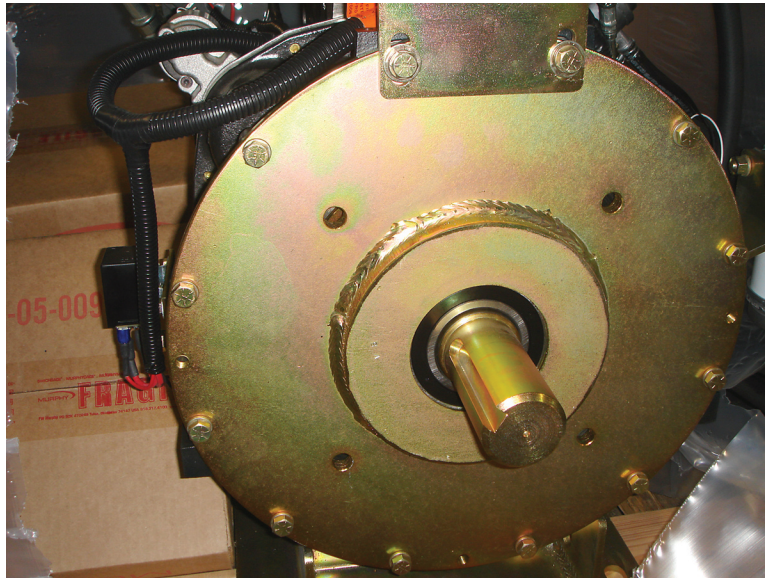

It is rare to have a stub shaft fail; however, as with any component, it may need to be replaced at some point. Some of the causes are:

- an over-tightened drive belt creating too much side load
- warping or grooving of the stub shaft caused by a failed bearing
- cracking or warping of the stub shaft caused by torque created by the sudden stop of the fan's drive train.

Whenever the auxiliary engine is changed, we recommend you also replace the stub shaft. To do this, follow the instructions below:

1. Turn off the sweeper power switch and/or disconnect the battery cable to prevent the sweeper engine from being started by accident.
2. Loosen, but DO NOT remove, the engine leg mounting bolts and nuts that hold the auxiliary engine legs to the engine skid.
3. Turn the jackscrew nuts so the engine is pushed toward the fan shaft.
4. The drive belt will become loose enough to be slipped from its pulleys as the engine skid moves towards the fan shaft.
5. Remove the 3/8" bolts and lock washers from the stub shaft pulley bushing.

6. Insert two of the 3/8" bolts into the two tapped holes of the stub shaft pulley bushing.
7. Tighten the bolts evenly by alternating from one to the other until both are tight. This procedure will push the pulley off the stub shaft pulley bushing.
8. Remove the pulley and its bushing from the stub shaft.
9. Remove the bearing plate from the end of the auxiliary engine. Look for any irregularities in the bearing plate. If you do not find any, you may use the bearing plate again.
10. Remove the old stub shaft from the end of the auxiliary engine.
11. Clean the flywheel and the replacement stub shaft using lacquer thinner.
12. Fasten the replacement stub shaft to the auxiliary engine using 32 ft. lbs. of torque on each bolt.
13. Use a dial indicator to ensure that the stub shaft is in line with the crankshaft. The stub shaft cannot be more than .007" off-center or it must be replaced.
14. Put the replacement bearing onto the end of the stub shaft. Use a piece of pipe, placed over the stub shaft's end, to drive the bearing down the stub shaft until it rests against the seat.
15. Slip the bearing plate down the stub shaft and onto the bearing.
16. Bolt the bearing plate to the auxiliary engine.
17. Slide the stub shaft pulley and its taper-lock bushing onto the end of the stub shaft.
18. Insert the bolts, through the taper-lock-bushing flange, into the pulley. To make sure the pulley is pulled onto the bushing evenly, alternate turning the three bolts.
19. Check the alignment of the pulley. To do this, use a string or straight edge from the face of one pulley to the face of the other. The pulleys should be in-line with each other. If this is not the case, back the stub shaft pulley off its bushing, move both in the proper direction for alignment, and then retighten the bushing/pulley bolts.

20. Inspect the drive belt for wear and replace it with a new one if needed.
21. Slide the drive belt onto the stub shaft and fan shaft pulleys.
22. Adjust the drive belt tension as outlined in the 'DRIVE BELT TENSION ADJUSTMENT' section.
23. Replace the belt guard.

C5. BOLT CHECK MAINTENANCE

All the mounting bolts on the sweeper, especially those on the engine and the fan housing, need to be inspected periodically. Due to the vibration of the sweeper's engine bolts can loosen or shear off. If any of the bolts are worn into the shoulder, replace them with a grade five (minimum) bolt of the same size. The following is a list of bolts that should be checked regularly:

Fan Housing And Engine Bolts

- Fan housing mount
- Motor mount to the engine skid
- Sweeper engine to the engine legs
- Bearing mount

Other Mounting Bolts

- Curb broom mounts
- Water pump
- Hydraulic pump
- Hydraulic reservoir
- Sweeping hood drag arms

C6. CURB BROOM MAINTENANCE



For the curb broom hydraulic system, follow the procedures outlined for the curb broom in the 'Periodic Maintenance Schedules' and in 'Sweeper Fluid Maintenance' sections.

C6a. Disc Adjustment

The curb broom is designed to be full floating. This means it will give way and 'float up' when it runs up against an obstruction. It will also automatically 'float' down to keep the broom in contact with the sweeping surface as the broom's bristles wear. Two adjustments can be made to improve the sweeping efficiency on irregular surfaces such as deep gutters.

Adjusting the boom disc should be done while the head is spinning and the bristles are touching the sweeping surface. This bristle-to-ground contact is called the 'curb broom pattern.' The two adjustments allow the operator to control which part, and how much of, the broom touches the sweeping surface. A general guideline for setting the curb broom pattern is to obtain a 9:00 to 1:00 bristle-to-ground contact on the left curb broom, and an 11:00 to 3:00 bristle-to-ground contact on the right curb broom. These patterns will efficiently remove material from the gutter and 'throw' it under the sweeper's sweeping hood.

The side-to-side tilt of the broom disc can also be adjusted so as to fit the 'pitch' of the sweeping surface. This is done by an electric actuator, which is operated by the broom tilt switch located on the control panel located in the cab. The actuator may be extended or retracted, which in turn changes the broom disc tilt.



The front-to-back angle of the broom disc is controlled by a turnbuckle that runs between the broom arm mounting bracket and the top of the broom motor mount.

This must be adjusted by hand. Loosen the jam nut on the turnbuckle that keeps it from self-adjusting, and insert a large screwdriver or wrench into the center to use as leverage. Turning the center shortens the turnbuckle and lowers the nose of the broom disc. Lengthening the turnbuckle raises the nose. When you have finished the adjustment, run the jam nut back tight against the turnbuckle so that it will not self-adjust during broom operation.



C6b. Cylinder Rod End Adjustment

Each broom cylinder utilizes a threaded rod and rod end to adjust the amount of the broom's vertical movement.

- To create **more cylinder stroke** (more broom arm movement),
screw the rod end away from the cylinder.
 - To **shorten the cylinder stroke** (create less movement),
screw the rod end toward the cylinder.

Always make sure the jam nut is tight against the rod end after adjusting!

Failure to do so may lead to detachment of the rod end from vibration, causing cylinder damage.

Adjustment

1. Remove from the broom arm the 5/8" bolt from the end of the cylinder.
2. Adjust the cylinder rod end. Screw the rod end toward the cylinder casing to shorten, or away from the cylinder casing to lengthen the cylinder's extension.
3. Reassemble the rod end to the broom arm with the 5/8" bolt.
4. Check the operation of the broom. Repeat the above procedure as needed until the broom operates as desired.

C6c. Bristle Replacement

1. To disassemble the curb broom, locate and loosen the three bolts on the top of the broom head. This will free the broom bristle section.
2. To replace the curb broom, position the new broom bristle sections, line up the bolt holes and tighten the three bolts.



C6d. Directional Valve Check

Hydraulic fluid flow is used to control the various functions of the curb broom such as raising, lowering and broom disc rotation. It is the job of the directional valve to determine the flow direction. If the directional valve is not operating correctly and is unable to reverse the hydraulic flow, the curb broom cannot operate properly. The broom may extend but will not retract, or a broom may retract and the disc rotates, but it won't extend. If the curb broom has either of these symptoms, the cause may be the directional valve.

NOTE: If the broom doesn't extend and the disc won't rotate, the problem could be in the lock valve. To determine if the directional valve is the problem, you may do a manual override check.

Manual Override Check XXXXXXXXXXXXXXXXXXXX

1. Locate the directional valve, which is located inside the manifold block located on the front of the hydraulic fluid reservoir.
2. Turn on the auxiliary engine. Turn on the broom by holding the broom activation switch in the UP position.

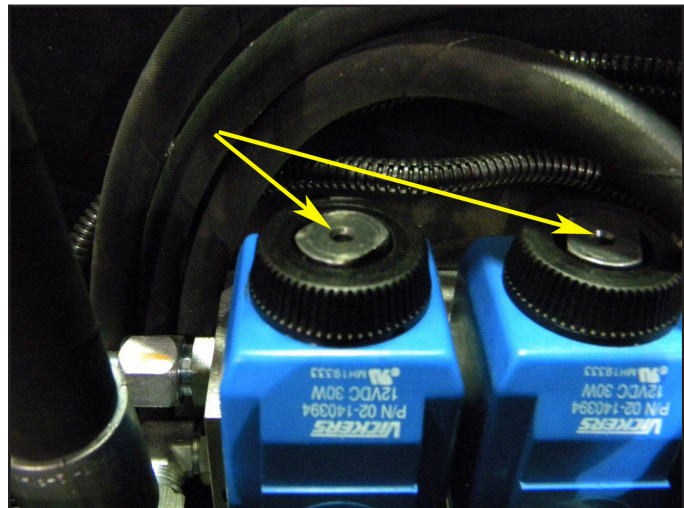

3. To test the directional valve, locate the small hole, about 1/8" in diameter, on either end of the it. With the auxiliary engine running, use a small nail or small Phillips-type screwdriver to insert into the holes. Do one hole at a time at either end of directional valve. This will manually override the directional valve. Initially you can easily push the plunger, and then a greater amount of pressure must be used to overcome the spring. If this procedure corrects the extension and retraction problem, then the directional valve is faulty. It will need to be repaired or replaced.

CAUTION: When overriding a rotating broom, do not stand in the broom's extension or retraction path.

C6e. Hydraulic System Servicing

***Check the hydraulic oil daily and
look for leaks in hydraulic hoses and fittings!***

If a leak is detected, repair it immediately to avoid hydraulic fluid leakage or dirt entering the system. This is a maintenance priority as the hydraulic system is vital to the daily operation of your sweeper. The level should be maintained at the 80% mark on the sight gauge, which is located on the front of the reservoir.

Follow the instructions under 'SWEEPER FLUID MAINTENANCE' for proper oil recommendation and change schedule. Also, follow the filter instructions under 'FILTERS MAINTENANCE.'

Leak Check

1. Check the hoses and fittings regularly for any signs of leakage. Most leaks will not cause immediate failure; however, once a leak has begun it will get worse. Repair all leaks as soon as they are discovered. First, try to tighten the fitting responsible for the leak. If this does not correct the problem, follow the instructions below.

Repair

1. Disconnect the leaking fitting.
2. Clean the seating surfaces.
3. If necessary, a sealing agent can be used on the non-JIC fittings. Use a sealing agent only on the upper threads of the non-JIC fittings to prevent contaminating the hydraulic fluid. The control valve orifices are so small that even minute pieces of debris can block them causing hydraulic problems.
4. Retighten the fitting.
5. Refill the hydraulic system with fluid as needed.

CAUTION: Do not use sealing agents on JIC or SAE fittings. On SAE fittings, always use hydraulic oil.

Directional Valve Configuration

(from left to right) XXXXXXXXXXXXXXXX

1. Bank 1 is door
2. Bank 2 is hopper
3. Bank 3 is head
4. Bank 4 is left curb broom
5. Bank 5 is right curb broom

C6f. Hydraulic Pump Pressure Check

Whenever the hydraulic cylinders and hydraulic motors will not function properly, there could be a problem with the hydraulic pump pressure. To check this problem, follow the instructions below:

1. Before making adjustments, check the electric and hydraulic system for any loose connections.
2. Check the hydraulic fittings and hoses for leaks.
3. Check the fluid for contamination and proper fill level.

DO NOT increase the pump pressure to compensate for leaking hoses, loose fittings, contaminated fluid or a clogged filter, as this can cause damage to the pump and other sweeper components.

Once you have made all possible hydraulic checks and you still believe there is a problem causing low fluid pressure from the pump, the pump's fluid pressure may be verified with help from another person. Follow the instructions below:



Pressure Test Nipple

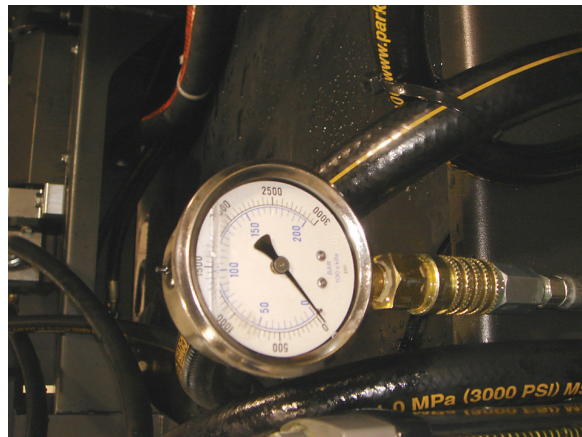

Pressure Test Gauge

Verify Hydraulic Pump Fluid Pressure

1. Attach a pressure gauge (able to measure at least 3000 psi) to the test nipple, which is located on the pressure port fittings of the hydraulic manifold.
2. Start the auxiliary engine and throttle up to approximately 2600 RPMs.

3. Have the second person hold the sweeping hood in the 'raise' position and continue to hold the switch in this position even after the sweeping hood is fully raised.
4. Check the pressure gauge. It should read 2200 psi while the switch is being held in the 'raise,' position.
5. If the pressure gauge readings are not within this range you may need to adjust the pressure relief valve.

System Pressure Relief Valve Adjustment

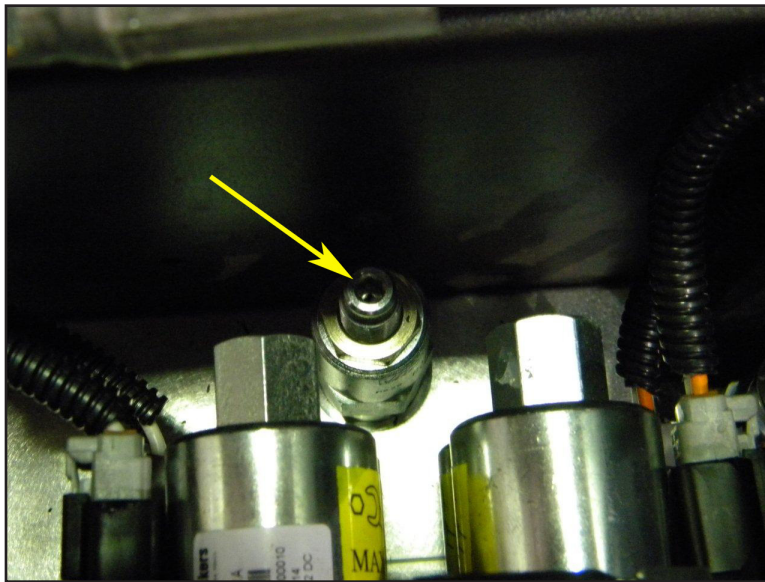

Pressure Relief Valve

1. Locate the relief valve. It is screwed into the top of the manifold block.
2. Loosen the relief valve stem's jam nut. Screw the relief valve stem in to increase the fluid pressure, or out to decrease it.

Do not turn the adjustment stem more than 1/8 of a complete revolution at a time.

C6g. Hydraulic Adjustment

The only time you may need to adjust the curb broom is when its return speed needs to be modified. The return speed is controlled by a flow-control valve, which is located on the auxiliary engine's manifold block.

Return speed should be between 1 and 3 seconds.

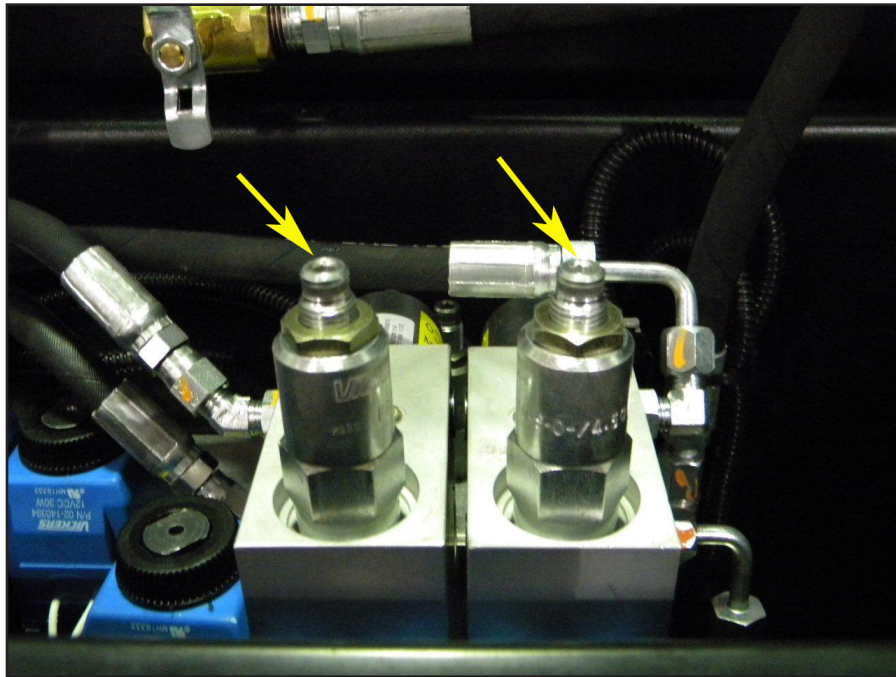

Flow Control Valve

1. Start the sweeper and run the curb broom for about 5 minutes.
2. Check the sight gauge on the hydraulic tank.
 - A. If the hydraulic fluid temperature HAS reached 80 degrees then proceed to step 3.
 - B. If the hydraulic fluid temperature has NOT reached 80 degrees, continue to run the sweeper and curb broom until it does. Then go to step 3.
3. Run the curb broom at normal operating RPMs and observe the return speed as you lower and raise the broom.
4. Back the valve's jam nut away from the valve body to allow for adjustment of the stem.

5. Insert an allen wrench into the end of the stem.
6. Choose one:
 - A. If the return speed is too fast, decrease the flow by turning the stem clockwise.
 - B. If the return speed is too slow, increase the flow by turning the stem counter-clockwise.
7. If the desired retraction speed has not been achieved, stop the broom and re-adjust the flow control valve.
8. When the return speed is between 1 and 3 seconds, stop the auxiliary engine and tighten the flow control valve's jam nut.

C7. DRIVE TRAIN MAINTENANCE

Follow the instructions in this section for replacement and servicing of the major components of the fan's drive train.

C7a. Drive Belt Tension Adjustment

During the sweeper's break-in period the drive belt will stretch noticeably. To prevent premature belt wear and maintain performance, it must be adjusted. After the first adjustment you will need to periodically check the drive belt for proper tension and to compensate for belt stretch. When the drive belt is properly adjusted, it should deflect downward approximately 1/2-inch at the midpoint between the two pulleys.

Before making this adjustment it is important to understand how the auxiliary engine is mounted, since the tension on the sweeper's drive belt is adjusted by repositioning the auxiliary engine.

The auxiliary engine is fastened to an engine cradle, which is mounted to the power module. To reposition the engine the nuts and bolts, which hold the auxiliary engine cradle to the power module, must be loosened. The engine cradle is attached to the power module by four bolts. In addition, two jackscrews, used for loosening and tightening the drive belt, are located on the left side of the engine.

The jackscrews are held in place by a set of jam nuts, as well as nuts located on each side of the engine skid wall through which they pass. When the inside set of nuts is loosened, and

then the outside set tightened, the auxiliary engine is repositioned away from the fan shaft.

When the outside set of nuts is loosened, and then the inside set tightened, the auxiliary engine is repositioned toward the fan shaft.

Adjustment

1. Turn off the sweeper power switch and/or disconnect the battery cable to prevent the engine from starting accidentally.
2. Before beginning this procedure, mark the engine's position with chalk or a grease pencil. Mark where both front and rear is located on the power module. This is your starting point. Next, measure back 1/4-inch from the first mark and make another mark, which is to indicate the amount of adjustment needed. By marking both the front and rear locations you will ensure that the adjustment is done evenly. The 1/4-inch adjusting mark is only a guideline. Always adjust the drive belt tension to the correct deflection specifications.
3. Loosen (DO NOT REMOVE) the engine leg mounting nuts and bolts that hold the auxiliary engine legs to the engine skid. Also, loosen the 9/16" nut located between the mounting bolts on both the front and the rear.
4. Loosen the inside set of jackscrew nuts and tighten both outer sets. Alternate from front-to-rear until the engine is to the adjustment mark.
5. Check the drive belt's tension. The belt should be adjusted so that it deflects 1/2-inch at the midway point between the pulleys. If the belt is too loose, repeat step 4. *Do not overtighten the belt.*
6. Check the alignment of the pulleys with a straight edge or, alternatively, a string placed across the front faces of the pulleys. If they are misaligned, the jackscrews may be used to manipulate the auxiliary engine's position relative to the fan shaft and bring the pulleys into correct alignment. However, if this is done then steps 4 and 5 must be repeated. **NOTE: If pulleys are misaligned, it will cause the belt to wear unevenly and reduce performance.**
7. Tighten the inside set of jackscrew nuts.
8. Retighten the four engine mounting bolts and the two slide-bar retaining nuts.
9. Reconnect the battery cable and/or insert keys.

10. Start the sweeper engine. Squealing or unusual vibrations indicate low drive belt tension. Adjust as needed.

C7b. Drive Belt Replacement

Drive belts become worn with normal use. We recommend that you replace the drive belt when it shows signs of wear. If you wait until it breaks, it will probably occur at a time that will create sweeper downtime. Replacing it before it breaks also assures optimum sweeper performance.

To replace the drive belt the sweeper engine will need to be repositioned. Review the 'DRIVE BELT TENSION ADJUSTMENT' section before you continue, as it will explain the mountings.

Also, before you begin this process, inspect the belt pulley for any excessive wear, nicks, or burrs. If any irregularities are found, you will need to replace the pulleys.

Removal Instructions

1. Turn off the sweeper power switch and/or disconnect the battery cable to prevent the sweeper engine from starting accidentally.
2. Loosen (DO NOT REMOVE) the mounting nuts and bolts on the sweeper engine that hold the cradle to the power module and the slide bar retaining nuts.
3. Loosen both sets of the outer jackscrew nuts, front and rear.
4. Slide the engine toward the center of the truck. If a pry bar is needed, DO NOT PRY AGAINST THE OIL PAN. This may cause permanent oil leaks and will void your warranty.
5. Slip the drive belt off the engine and fan shaft pulleys.

Replacement Instructions

1. Check the pulley grooves for burrs or any other irregularities that may cause abnormal belt wear. Correct if needed.
2. Position the replacement drive belt on its engine and fan shaft pulleys.

3. Loosen the inside set of jackscrew nuts and tighten both outer sets. Alternate from front to rear until the engine has been repositioned away from the center of the truck and the belt is reasonably tight.
4. Check the drive belt tension. Adjust the belt so that it deflects 1/2-inch at the midway point between the pulleys. **DO NOT OVERTIGHTEN THE BELT.** If the belt is too loose, repeat step 3.
5. Check the alignment of the pulleys with a straight edge or string. Place it across the front faces of the pulley. If the pulleys are not in line, the jackscrews may be used to manipulate the auxiliary engine's position relative to the fan shaft, which should bring the pulleys into line. Then, repeat steps 6 and 7. Misalignment will cause the belt to wear unevenly and reduce performance.
6. Once you have made the proper adjustments, tighten the inner set of jackscrew nuts, front to rear.
7. Tighten the engine leg's mounting nuts and bolts and the slide-bar retaining nuts.
8. Reconnect the battery cable and start the sweeper engine. If you hear any squealing or feel abnormal vibrations, this means the drive belt tension is too low. Adjust, if needed, by repeating from step 6.

C8. FAN HOUSING MAINTENANCE

The fan housing directs the flow of air from the fan to the sweeping hood. To provide maximum performance it should be checked for wear on a regular basis.

C8a. Fan Housing Inspection

A small amount of fine dust is pulled into the fan chamber when air is drawn from the hopper into the fan housing. This fine dust wears the fan blades, fan housing liner and the heads of the fan housing liner bolts. Over time, this sandblasting effect of fine dust will eventually wear out the components and they will need to be replaced.

A worn fan blade can break and damage the inside of the fan housing, which is both dangerous and costly. Worn liner bolts may allow the fan housing liner to sag, causing damage to the fan as well as to its shafts and bearings.

Also, a worn liner permits the sandblasting effect of the air stream to reach the walls of the fan housing, which is an expensive item to replace.

Inspection Procedure:

1. Raise the hopper and place the safety chocks on each of the dump cylinders.
2. Turn off the sweeper power switch and disconnect the battery cable to prevent it from accidentally starting.
3. Remove the back plate.
4. Use a flashlight to inspect the fan blades, fan bushing, the fan housing liner bolts and the fan housing liner.
5. If no abnormal or excess wear is evident, replace the back plate.
6. Remove the safety chocks and reconnect the battery cables.

C8b. Fan Replacement

Any time a worn fan is causing reduced sweeping efficiency, you should replace it immediately. The fan shaft bearings have roughly the same life expectancy and should be replaced at the same time. This is a labor-intensive operation and it is recommended that you replace both components at the same time in order to save time and money from downtime.

There are two exceptions to this rule:

1. If you do not use the sweeper's water system or you sweep in extremely sandy conditions, you will have to replace fans more often than bearings.
2. If the proper bearing lubrication procedures have not been followed, you may have to replace the bearing more than the fan.

However, in most cases, it is recommended that the fan and bearings be replaced at the same time.

Fan Replacement Disassembly

See page 43 for fan wear description/photo.

1. Raise the hopper and place the safety chocks on each of the dump cylinders.

2. Turn off the sweeper's power switch and disconnect the battery cable to prevent the engine from accidentally starting.
3. Remove the 3/8" lock nuts and washers from around the back cover plate and lift it off.
4. Remove the 3/8" bolts and lock washers from the fan's bushing.
5. Reinsert two 3/8" bolts into the tapped holes of the bushing. Tighten these bolts evenly. This procedure will push the fan off the bushing.
6. Use a gear puller to remove the bushing from the fan shaft.
7. Remove the fan from the fan shaft and fan housing.
8. Once you have the fan out, check the rubber liner inside the fan housing. If you notice excessive wear, replace the liner. Failure to replace this inexpensive liner could result in having to replace the expensive fan housing prematurely. For instructions on this procedure see 'FAN HOUSING LINER REPLACEMENT'.

Replacing The Fan

1. Inspect the end of the fan shaft for damage. Remove any burrs or rust from the shaft end with sandpaper.
2. Place the fan on the fan shaft and push it back into the fan housing.
3. Inspect the bushing for cracks or any other damage. The original bushing may be reused.
4. Apply an anti-seize agent to the tapered area of the bushing.
5. Slip the key into the bushing/fan shaft keyway.
6. Position the fan bushing onto the fan shaft while aligning it with the shaft key as well as the fan. If necessary, spread the bushing apart; however, keep in mind that it will crack if it is overspread.
7. Drive the fan bushing onto the fan shaft until approximately 1/4-inch of the shaft extends from the face of the bushing. You may need to use a rubber hammer (or wooden block with metal hammer) to drive the bushing on.

8. Insert the three 3/8" bolts, with lock washers, through the untapped bushing holes and into the tapped holes of the fan. Finger-tighten the bolts. DO NOT tighten the bolts so as to secure the fan to the shaft.
9. Apply strip caulk, or a similar sealing agent, to the face of the fan housing.
10. Install the back cover plate. It may be necessary to move the fan and its bushing further into the fan housing before the back cover plate can be mounted. Before you tighten the bolts, pull the fan back until it touches the back cover plate's inlet ring. Using the available slack, center the cover plate's inlet ring in the fan's orifice. Feel around the perimeter of the inlet ring to make sure the gap is even.
11. Tighten the cover plate bolts.
12. Move the fan back onto the fan shaft. An ideal gap distance is 1/4-inch from the cover plate orifice to the narrowest part of the fan's orifice. See the illustration below.
13. Position the fan onto the fan shaft. Keep in mind that as the fan is tightened onto its bushing, it will travel roughly 1/4-inch toward the cover plate's orifice.
14. While holding the fan shaft in position, tap the fan bushing along the fan shaft and into the fan's hub.
15. When the fan bushing is snug inside the fan's hub, insert the 3/8" bolts and tighten the fan onto the fan bushing. As the bolts are tightened and the fan drawn onto the bushing, the fan should move 1/4-inch toward the cover plate.
16. Turn the fan to determine if the two orifices rub as it rotates. If the orifices do not touch, proceed on to step 17. If the orifices do touch, mark the bushing's present location on the fan shaft to provide a reference point. Remove the fan from its bushing and follow steps 13-15 in order to remount the fan further into the fan housing.
17. Once the fan is properly mounted, remove the hopper safety chocks and lower the hopper.
18. Reconnect the battery cable.

19. Start the auxiliary engine and listen for sounds of contact between the cover plate orifice and the fan orifice. If none are heard the unit is now ready to sweep. If any such sounds are detected, raise the hopper and readjust the fan.

C8c. Fan Housing Liner Maintenance

To prevent damage due to air-blasts from the fan, a rubber liner is attached to the inside of the fan housing. Regularly check the liner for pitted areas, tears, holes or worn liner bolts. If the liner is worn, it will expose the fan housing to direct wear. When compared to replacing the fan housing liner, the fan housing is an expensive item to replace.

Fan Housing Liner Replacement

1. Follow steps 1–7 under 'FAN REPLACEMENT DISASSEMBLY.'
2. Unscrew the 3/8" nuts from around the outside of the fan housing and remove the elevator bolts holding the rubber liner in place. Inspect the condition of the fan housing liner bolts. Any worn bolts should be replaced with new ones upon reinstallation.
3. Remove the worn liner in one piece, if possible. Save it to use as a template to mark the new liner's hole pattern.
4. Place the old liner on top of the replacement liner material and mark the length and hole pattern with spray paint.
5. Cut the liner material to length and use a drill to make the holes.
6. The replacement liner hole pattern is different at each end. Be sure to position the liner so that its holes match the hole pattern of the fan housing.
7. Start by installing the elevator bolts, which hold the rubber liner to the top of the fan housing. Continue installing the remainder of the elevator bolts, working out and down from the top of the fan housing.
8. Check the fan blades for wear and replace them if needed. To replace the fan, follow steps 1 through 19 of 'FAN REPLACEMENT.'

C8d. Fan Shaft Bearing Maintenance

With the proper lubrication, and under normal operating conditions, the bearings should last approximately 2500 hours. Premature bearing failure is usually due to improper lubrication procedures. If the bearing is requiring replacement more frequently than normal, review and adhere to the bearing lubrication section in this manual.

When the bearing fails, it is accompanied by abnormal noise(s), vibration and/or grease slinging caused by ruptured bearing seals. If this happens, the worn bearings need to be replaced immediately to prevent damage to other sweeping components. Normally, when replacing the bearing the fan shaft and accompanying drive belts, pulleys and, bushings should also be replaced. Replacing them all at once saves repetitive maintenance and downtime.

On new sweepers, or sweepers that have been exceptionally maintained, only the bearing insert may need to be replaced. However, needing to replace only the bearing inserts is rare. If the bearing casings are not damaged and can be slid off the fan shaft, then the bearing inserts can be replaced. This procedure can only be performed if the fan shaft is free from paint, rust and burrs, or when it has not been otherwise damaged.

Fan Shaft Bearing Lubrication

The two pre-lubricated bearings on the fan shaft should be re-lubricated after 250 hours of operation. Check the sweeper engine's hour meter and lubrication chart to determine when this maintenance is due to be done.

Use only a lithium-based grease, one conforming to NLGI Number 2 consistency. The grease must be free from any chemical impurities such as free acid and free alkali. It must also be free from physical impurities such as metal, rust, dust, and other abrasive particles. This light-viscosity, low-torque grease is used because of its water-insoluble rust inhibitors and its operating temperature range that makes it chemically and mechanically stable. Its normal operating temperature range of -30 degrees to +250 degrees Fahrenheit is ideal for sweeper operations.

1. Prior to lubrication, run the auxiliary engine to heat up the old grease. Once the bearing grease has warmed, turn the auxiliary engine off and remove the keys.
2. Using a hand-operated grease gun, very slowly apply one pump of grease to the bearing (a small bead should form around the bearing seal when running).

This should be about 1/4 ounce of grease. The bead indicates that adequate lubrication has been applied, as well as provides a protective seal against foreign material entering the bearing.

There is generally a slight rise in operating temperature (10-30 degrees Fahrenheit) after the bearing has been re-lubricated. This rise will continue until the grease stabilizes in the bearing chamber.

Never use more than one pump of grease, or grease the bearings more often than every 250 hours of operation. *Over-greasing the bearing will shorten its life through causing the bearing to overheat and fail.*

Fan Shaft Bearing Disassembly

1. Raise the hopper and place the safety chocks over the dump cylinders.
2. Remove the sweeper engine battery cable to prevent the engine from accidentally starting.
3. Remove the 3/8" nuts and flat washers from around the fan housing's back plate.
4. Lift the back plate off the fan housing studs.

At this point, two options exist. These are to either remove the fan wheel separately, or to remove it as a unit with the fan shaft. If you choose to remove the fan wheel separately, follow steps 5-9. To remove it with the fan shaft, skip to step 10.

5. Remove the three 3/8" bolts and lock washers from the fan bushing.
6. Insert two of the 3/8" bolts into the tapped holes of the fan bushing.
7. Tighten the bolts by alternating from one to the other. This procedure will push the fan off the fan bushing.
8. Using a gear puller, remove the fan bushing from the fan shaft. The fan shaft key will come off with the bushing.
9. Slide the fan off the fan shaft.
10. Relieve the drive belt tension by following the steps detailed in the removal section of 'DRIVE BELT REPLACEMENT.'

11. Remove the drive belt from the fan shaft pulley and then remove the fan drive pulley from the fan shaft.
12. Remove the two 5/8" bolts from each of the fan shaft bearings.
13. If you are removing the fan wheel with the shaft as an assembly, remove the four fan back plate nuts. Next, remove the fan wheel and the shaft assembly from the fan housing as a unit. If you are removing the fan wheel separately, skip this step.
14. Pull the fan shaft assembly from the power module's shelf. This consists of the fan shaft and the two fan shaft bearings.
15. Wrap the middle of the shaft in a cloth and insert the protected portion in a vise. Using 80-grit sandpaper, use the 'shoeshine' technique to buff any surface irregularities off the parts of the fan shaft over which you will be sliding the old bearings. When you have finished, remove the shaft from the vise.
16. Loosen the lock collars from the fan shaft bearings (older models have set screws) and slide the fan shaft bearings from the fan shaft. If difficulty driving the bearing from the shaft is encountered, place a soft object (such as a brass bar or pipe) against the inner race. **Do not hammer directly on the bearing.**
17. If you are replacing the bearing inserts only, skip to that section.
18. Inspect the fan shaft and the fan shaft pulley. If either one is damaged or worn too much for reuse, discard and replace.

Replacement of Fan Shaft and Fan Shaft Pulley

1. Prior to replacing the fan shaft, inspect it for burrs, nicks and rust. If any are found they must be removed. To do this, wrap the middle of the shaft in a cloth and insert the protected part in a vise. Use 80-grit sandpaper to buff off any surface irregularities. Buff using a 'shoeshine' manner. When you have completed this, remove the shaft from the vise.
2. If the old fan shaft and fan shaft drive pulley will not be reused, slide the new fan shaft drive pulley, along with its bushing, onto the fan shaft. Spread the bushing apart if needed. **Do not over spread the bushing, as it will crack.** If the old fan shaft and fan shaft drive pulley are being reused, some

repositioning of the pulley may be required when it is reinstalled. Back the pulley off its bushing to loosen it on the shaft for later repositioning.

3. Loosen the lock collars on the replacement fan shaft bearings.
4. Slip the fan shaft bearings onto the fan shaft. If the bearings do not slip on easily, **do not hammer the ends of the inner race**. The inner races are soft and will damage easily. If force is needed to position the bearing on the fan shaft, use a brass bar or pipe against the inner race to drive the fan shaft bearing into place.
5. Position each fan shaft bearing on top of the power module's shelf and align it with the mounting holes.
6. Place the two 5/8" bolts, flat washers and lock washers into each bearing. Tighten them down to the power module's shelf.
7. Position the fan shaft in the bearings so that 5" of the shaft extends into the fan housing.
8. Apply a drop of 'Loc-Tite,' or equivalent, to the bearing lock collar screw and tighten it.
9. Position the fan shaft drive pulley's bushing such that when the fan shaft drive pulley is tightened onto it, the pulley is drawn into alignment with the drive pulley of the engine.
10. Insert the fan shaft drive pulley bushing's 3/8" bolts, with lock washers, through the untapped holes of the bushing. Screw them into the fan shaft drive pulley.
11. Inspect the fan for wear and replace it with a new one, if needed.
12. Follow the steps outlined in the 'FAN REPLACEMENT' section of this Manual if the fan wheel was removed separately.
13. Adjust the drive belt tension as outlined in the 'DRIVE BELT TENSION ADJUSTMENT' section of this Manual.
14. Remove the dump cylinder safety chocks.
15. Reconnect the engine's battery cable. Lower the hopper and resume operation with the sweeper.

Bearing Insert Replacement

The fan shaft bearings have been designed to allow for easy insert replacement. Replacing the bearing insert is less expensive than replacing the complete bearing; however, this is not always possible. It can only be done if the bearing can be removed from the fan shaft without any damage to the bearing casing.

1. Follow the instructions under 'FAN SHAFT BEARING DISASSEMBLY,' steps 1 through 17.
2. Remove and save the grease fittings from the top of each bearing case.
3. Remove the locking pin from the pathway below the grease fitting and save this pin.
4. Remove the old insert by prying up one edge of the insert using a claw hammer. The insert will come out of the slots on the rear of the bearing casing. Discard the old inserts.
5. Align the insert recess with the grease-fitting hole of the bearing case.
6. The new insert should slip easily into the slotted rear of each bearing case.
7. The original locking pin will fit loosely into the grease pathway. **The original locking pin must be used, and the pin and insert dimple must be in the proper position before replacing the grease fitting!**
8. Reinstall the grease fitting at the top of the bearing case.
9. Follow steps 1–17 of the 'FAN SHAFT BEARING REPLACEMENT' section of this Manual.

C9. SEAL MAINTENANCE

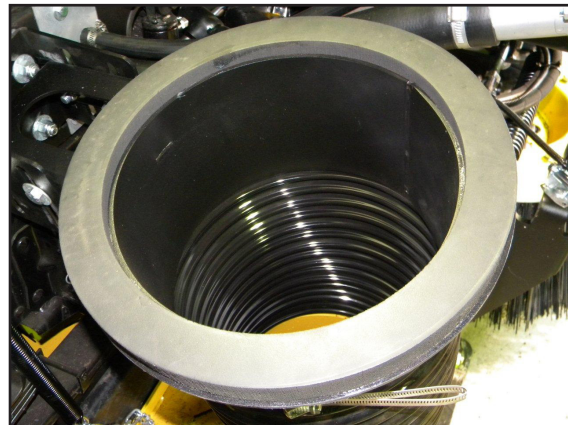
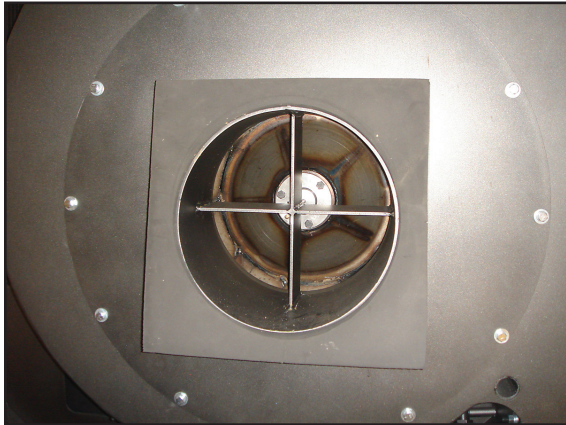

Fan Seal and Suction Hose Intake Seal

Since the sweeper's pickup power is vacuum-dependent, maintaining a tight seal is extremely important. If this seal is not in the best condition possible, it can make a vital difference in the sweeper's ability to pick up debris. The sweeper's seals are located on the fan housing and suction inlet tubes. Lubricate the seals with a high quality grade of petroleum-based jelly or grease to keep them resilient.

The side inspection doors, dump doors and screen access door will not require lubrication.

To extend the life of the seals when the sweeper is parked for an extended period of time, leave the hopper raised a few inches so the fan and intake seals can regain and keep their shape.

Over time, the seals will eventually become worn or non-resilient. When this happens you will notice a loss of vacuum power. To preserve the sweeping efficiency you will need to replace these seals periodically.

To Replace the Seals:

1. Elevate the hopper completely and place the safety chocks on each of the dump cylinders.
2. Pull the seal off of the surface on which it has been mounted. Remove any of the glue particles or remaining seal with a putty knife, sandpaper or grinder.
3. Clean the surface with lacquer thinner or any suitable de-greasing agent.

4. Use a waterproof weather-stripping adhesive that will not dissolve the rubber and apply according the manufacturer's directions. (3M brand adhesive #8001 works well for this)
5. Place the foam seal onto the mounting surface.
6. Make sure the glue dries before lowering the hopper onto the new seal(s). This is to prevent the seals from sliding away from the correct position.
7. Lubricate the new seal(s) with petroleum jelly or grease before using. Maintain lubrication throughout the life of the seal.

C10. SWEEPER ENGINE/FAN RPM CHECK

If the sweeper isn't picking up debris efficiently, the problem may be with the sweeper engine's RPM. Every engine's RPM is pre-set at the factory, altering the setting will void the engine's warranty. However, to determine if low RPM could be causing the problem, it should be measured to check for poor performance. The fan shaft's RPM should also be measured.

To check the RPM readings it may be necessary to remove the fan belt guard and fan shaft guard. **Be extremely careful while working around the drive belt(s).**

Make these measurements with a suitable tachometer and with the engine at full throttle. If the engine, at full throttle, is running at significantly lower than 3000 RPM's, check the linkage between the throttle cable and the engine. If the throttle cable is properly linked to the engine, and the sweeper engine RPM is still low, your engine must be taken to an authorized service center.

If the sweeper engine's RPM is correct, but the fan RPM is low, a loose drive belt is indicated. Follow the instructions for tightening the main drive belt in the section 'DRIVE BELT ADJUSTMENT.'

The fan RPM should be approximately 1.35 times the engine RPM. *Do not tamper with the governor, as this will void the engine's warranty!*

If the RPM readings of both shafts, at full throttle, are close to the tabulated values, then the inefficient pickup is caused by something else. If this is the case, refer to the Troubleshooting section of this Manual.

C11. SWEEPER FLUID MAINTENANCE

C11a. Auxiliary Engine Cooling System

Refer to your auxiliary engine Owner's Manual for the care and maintenance of the cooling system.

C11b. Auxiliary Engine Oil

Refer to your auxiliary engine owner's manual for the manufacturer's suggested oil change schedule and type of oil to use. Use the auxiliary engine's oil drain hose to drain the auxiliary engine oil pan. The hose looks like a hydraulic hose and is located underneath the auxiliary engine. Unscrew and remove the JIC plug, located in the end of the hose, to drain the oil into a container. Be sure to dispose of the oil properly.

Note: For faster and more thorough drainage, you should warm the engine prior to changing oil.

C11c. Hydraulic System

Always maintain the hydraulic oil level at the full mark on the sight level gauge. This gauge is located on the side of the hydraulic reservoir. Change the hydraulic oil after the first 500 hours of operation, then every 2,000 hours thereafter.

If the hydraulic oil becomes cloudy, it is an indication that water has contaminated the system and the fluid needs to be changed. Changing the fluid should only be done after you have determined the source of water contamination. **Do not operate the sweeper with contaminated hydraulic fluid.**

At the factory, the hydraulic system is filled with AW 46 hydraulic fluid. Whenever the hydraulic fluid is added to or changed, use this type or equivalent 20-weight (SAE) hydraulic oil.

NOTE: A system that operates with an ambient fluid temperature greater than 100 degrees Fahrenheit requires 30-weight (SAE) hydraulic oil.

C12. SWEEPER FILTER MAINTENANCE

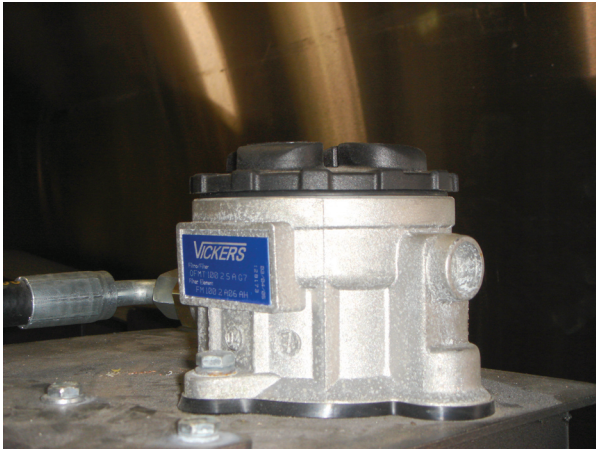

Hydraulic Return Filter

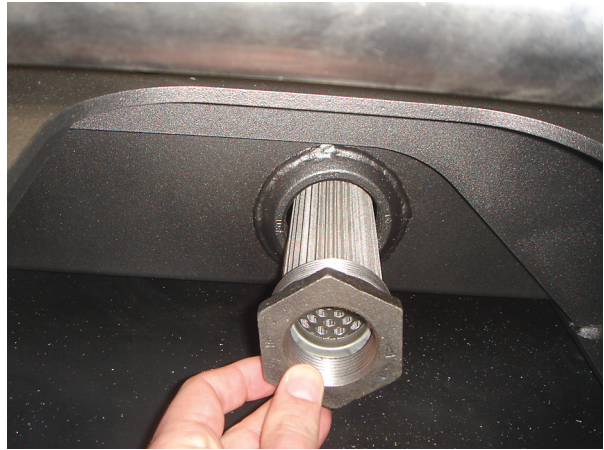

Bushing-Like Suction Filter

C12a. Auxiliary Engine Filters

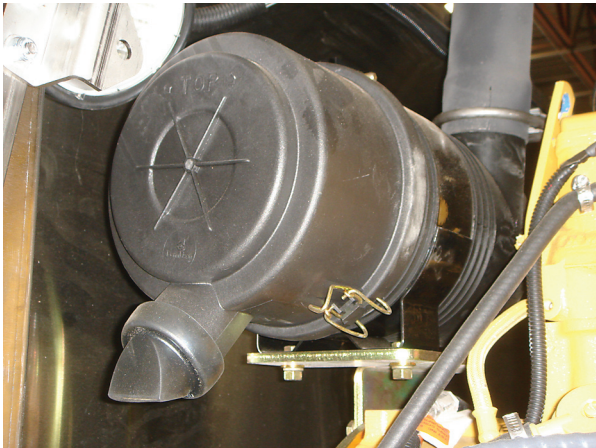

Dual Element Air Filter 1834



Oil Filter & Fuel Filter 1832

The auxiliary engine has three filters: an oil filter, a fuel filter and a dual element air filter. At a minimum, all filters should be changed according the manufacturer's warranty recommendation. Stewart-Amos Sweeper Co. recommends that the oil filter be changed more often if the sweeper is operated under unusually dusty circumstances.

The air filter has a built-in air indicator. This air restriction indicator is usually placed on or near the auxiliary engine's air filter canister. When the air filter becomes clogged and needs

service, a window on the air restriction indicator changes color. Depending on the type of unit used, the color may change from clear to red, clear to yellow, or yellow to red.

For air filter change and servicing information, see the auxiliary engine's Owner's Manual.

NOTE: Change the air filter ONLY when the air restriction indicator's 'need to service' window has changed color. Air cleaner over-servicing can cause serious engine damage.

C12b. Hydraulic System Filters

The hydraulic tank, which supplies oil to the hydraulic system, has two filters: a suction filter and a return filter. These filters remove from the hydraulic oil any foreign particles that might cause damage to the hydraulic system parts.

The suction filter is difficult to locate because the major portion of its body is hidden within the hydraulic tank. The only part that can be seen is the large, bushing-like head protruding from the suction line's tank flange that is positioned at the bottom of the hydraulic tank. The hydraulic tank must be drained before the suction line fittings can be removed. This filter should be replaced after the first 500 hours of operation and then every 2,000 miles thereafter.

To Change the Filter:

1. Locate the hydraulic tank drain hose.
2. Remove the plug.
3. Open the ball valve and drain the fluid into a proper receptacle.
4. Locate the two hydraulic filters.
5. Remove the fittings from the lower suction filter, and then unscrew the filter from the tank.
6. The old suction filter may be discarded and replaced or, depending on its condition, cleaned with an approved cleaning solvent.
7. When you replace the filter, use S-25 suction filters. Screw the suction filter back into its hydraulic tank flange and replace the hydraulic fittings that connect the suction hose to the suction filter.

10. Locate the upper return filter. Unscrew and lift basket filter out.
11. Replace with new filter and replace lid.
12. Refill the reservoir with fresh hydraulic oil at the breather cap to approximately 80% of the full mark on the sight gauge scale. AW46, or equivalent 20W hydraulic oil, should be used.
13. Check the hydraulic oil fluid level after operating the sweeper for a brief period, refilling the system if needed. Perform a thorough leak inspection of the hydraulic fittings on the filters and the curb broom system's hydraulic pump.

C13. SWEEPING HOOD MAINTENANCE

The sweeping hood has been designed to maximize debris pickup via a forced air and vacuum system. Without proper care and maintenance, the sweeping hood cannot provide the necessary and desired sweeping results. (Note: Photos show the Stewart-Amos optional, patent-pending, Vector hood.)

C13a. Sweeping Hood Tension Spring Adjustment

Near the four corners of the sweeping hood are the sweeping hood tension springs. These springs help the sweeping hood to 'float' by relieving some of its weight from the sweeping surface. When the springs are adjusted correctly, you should be able to grasp the front corner of the sweeping hood with your hand and move it slightly with roughly 40 pounds of upward lift. This is the normal setting; however, some operator preference varies. Less tension shortens runner life. More tension creates a possibility that the hood may bounce on irregular surfaces, breaking the suction seal.

Fine Adjustment

1. Locate the eyebolt that connects the head-spring to the frame.
2. Loosen or tighten the nut on the end of each eyebolt to raise or lower the head.



Coarse Adjustment

1. Raise the sweeping hood.
2. Unhook the chains from the springs or remove the 5/16" bolts that hold the spring chains to each side of the head.
3. Increase or decrease the number of chain links between the hood retainers and the ends of the hood springs, as needed.
4. If adjusting the hood spring tension does not correct the problem of excessive runner wear, the problem may be bent or uneven drag arms.



C13b. Worn Flaps

When new, the sweeping hood flaps will extend past the bottom of the skid plate. As you use the sweeper more they will hang straight down and lose contact with the ground. When this happens, it is time to replace the flaps.

Caution! Do not attempt to adjust the skid plates to extend the life of the flaps. The hood's blast orifice must never be less than 1 ½ inches from the ground.

C13c. Replacing the Flaps

The sweeping hood is dependent upon forced air movement to provide maximum sweeping results. The flaps underneath the sweeping hood must maintain the air stream as it moves across the hood to the vacuum tube. The flaps may be allowed to wear until they hang straight down, and then should be replaced.

C13d. Sweeping Hood Removal

To remove the hood, remove the bolts holding the tension chains, hood cylinder chains and drag arms. Disconnect the water line. Then, loosen the hose clamps holding the 12-inch flex hoses to the hood. Lift the driver's side of the truck chassis with a floor jack and slide the hood out.

Turn the sweeping hood over. Place the hood on a work table or saw horses to make both the top and bottom sides accessible. Remove the knobs holding the front flap support channel. Remove the ¼" bolts and lock nuts that hold the front flap in place.

Discard the worn flap and install the new. The bolt heads should be on the air channel side of the hood, with the lock nuts on the top. Reinstall the support channel with the knobs. Slide the channel all the way to the front of the hood to allow the least amount of contact with the sweeping surface. Remove the ¼" bolts and lock nuts holding the center flap in place. Remove the worn flap and replace with the new.

Turn the hood back over, so the runners are down. Remove the lock nuts that hold the rear cartridge in place. Remove the adjuster knobs and remove the worn cartridge. Make sure the bolts in the slide bars move freely. Thread the adjuster knobs onto the new cartridge and slide the adjuster bolts into the slots on the hood.

The slide bolt should insert into the holes in the cartridge. Loosely thread the lock nuts onto the slide bolts. Adjust the cartridge so the flap just touches the sweeping surface. Tighten the lock nuts. Tighten the adjuster knobs.

C13e. Reinstalling the Sweeping Hood

Raise the driver's side of the truck about three inches. Slide the sweeping hood under. Lower the truck. Reattach the drag arms, hood jump chain, and tension chains. (Reverse the removal instructions detailed in the previous section. Slide the 12-inch flex hose over the head tubes, and tighten the hose clamps.

C13f. Skid Plate Adjustment and Replacement

The skid plate on the sweeping hood has been designed for low maintenance and durability. The skid plates are exposed to extreme punishment due to the job they perform. Therefore, we have inserted tungsten carbide inserts in the runners to give them the longest life possible. You will need to replace the skid plate when its runner is worn through 80%.

Adjustment

Caution! Do not adjust the skid plates so far up that the hood's blast orifice is less than 1 ½ inches from the ground.

Remember: Whenever skid plate adjustment is necessary, the blast orifice must remain 1 ½-to-2 ¼ inches from the ground. Less than 1 ½ inches, the air stream becomes choked down. More than 2 ¼ inches and the blast velocity of the air striking the ground is lost.

Never adjust the skid plates so as to extend the life of the flaps. When the flaps no longer maintain a good seal, they should be replaced. Adjusting the skid plates may affect the sweeping efficiency as a result of the change in blast orifice-to-ground distance. **To adjust:**

1. Raise the sweeping hood and locate the skid plates on either side.
2. Loosen the 5/8" nuts on each of the sweeping hood skid plates.
3. Slide each skid plate up or down its slots to achieve the required blast orifice to sweeping surface distance.
4. Retighten the 5/8 nuts on each of the sweeping hood skid plates.
5. Lower the sweeping hood and make sure that the skids are riding flat on the ground.



Replacement

To remove or replace the skid plate, use the following instructions:

1. Locate the skid plates. There is one plate on each side of the sweeping hood. You will notice that bolts protrude through the skid plates. The skid plates are held in place against the hood by nuts and washers.
2. Raise the sweeping hood and remove the skid plate's nuts and washers. Set the nuts and washers aside for reuse.
3. Pull the old skid from the side of the sweeping hood and replace it with a new one.
4. Use the nuts and washers that you set aside and screw them down against the skid plate. Do not tighten them until the new skid plate is in the proper position. Once you have the skid plate in the desired position then tighten all the nuts and washers.

Seasonal Changes

The sweeping hood's orientation to the ground may be manipulated by using some creative skid plate adjustments designed to maximize performance in various seasonal conditions. By adjusting the leading ends of the skid plates up more than their trailing ends, the pickup hood can be set to minimize frontal area. This is often preferable during heavy cleanup periods, such as Spring cleanup season time. Adjustment in this way provides a faster channel of air/debris mixture and less distance that the debris must move.

Just as making the frontal area shorter increases heavy sweeping performance, making the frontal area higher increases sweeping performance in lighter debris. This adjustment may be accomplished by performing the opposite of the above procedure, adjust the skid plates' trailing ends up more than their leading ends. This is extremely helpful during the fall when leaves must be swept.

(Please note: These adjustments should only be made under extreme conditions. At all other times, the factory recommended adjustments will usually suffice. Prolonged usage with the above adjustments will require flap replacement when a re-adjustment to normal conditions is made.)

C14. WATER SYSTEM MAINTENANCE

The standard water system consists of a gravity-feed water line, which connects to the sweeping hood and a Shur-Flo water pump for dust suppression for the hopper, curb broom and optional front spray bar.

The water line to the sweeping hood needs only an occasional check beneath the sweeping hood to be sure that its outlet has not become clogged.

The water strainer should be cleaned daily and the water nozzles checked for correct operation and cleaned as needed.

When freezing temperatures are expected, either drain the water reservoir and remove filter cap or add antifreeze to the water as per the antifreeze manufacturer's instructions.

C14a. Water Pump

This sweeper is equipped with two Shur-Flo water pumps. Maintenance and troubleshooting procedures for the water pump are included in the Shur-Flo Pump Manual, which is included with the sweeper.



C14b. Water Filter Cleaning

The purpose of the water filter is to remove any particles from the water that might cause failure of the dust suppression system's spray nozzles. The plastic strainer is located beneath the left water reservoir, positioned in-line between the water reservoir and the water pump. The cap spins off easily for daily flushing.

Approximately once a week the reservoir should be drained, the bottom of the strainer unscrewed, and the cylindrical screen within the strainer removed and cleaned. The frequency of this cleaning procedure will vary depending on the purity of the water from its fill source.

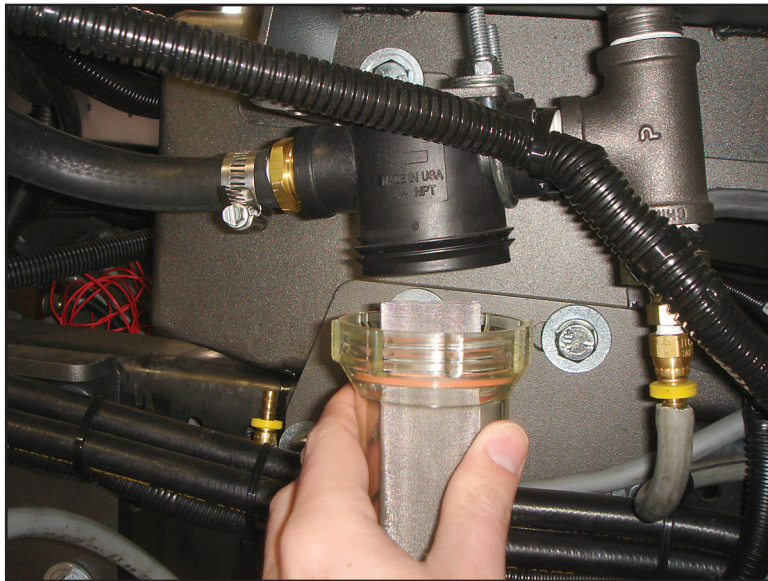

'Y' Strainer Disassembly

Cleaning

1. To drain, unscrew the bottom of the strainer. Remove and clean its screen.
2. Reassemble the strainer.

C14c. Water System Winterization

Whenever the dust suppression system is going to be used when the temperatures are expected to drop below freezing, environmentally-safe antifreeze should be added to the reservoir's water. Follow the antifreeze manufacturer's instructions for mixing.

To drain the water from the reservoir, remove the strainer bowl under the water reservoir. Once the reservoir has emptied, reinstall the strainer bowl. Run the Flow-Jet pump to clean

out any remaining water in the lines.

D. SUGGESTED SPARE PARTS LIST

All mechanical devices have parts that wear out over time. Stewart-Amos Sweeper Co. has designed your sweeper keeping both the availability and cost of parts as key concerns. Many replacement parts can be found at your local hardware store while others will have to be obtained from Stewart-Amos Sweeper Co.

The time involved in obtaining parts and replacing them is referred to as 'down time'. Down time is costly especially if your sweeper is inoperable for a number of days. To keep down-time at a minimum, we recommend that you maintain a small parts inventory at your location. We suggest the following parts:

PART DESCRIPTION	PART NUMBER	SUGGESTED QUANTITY
Fan seal	2000044	1
Intake seal	SPX24046	1
Hopper intake tube	200235	1
Flap set	SPX29336	1
Intake/pressure hose H/D	SPX21033HD	1
Drive belt	50804	1
Skid	SPX520425	2
Drag arm	600050	1
Inspection door seal	50407-068	1
Top door seal	50407-202	1
Dump door seal	50407- 192	1

Avoiding a single day's down time will make the initial investment justify the expense. Plan ahead so you can avoid down time and save on parts by eliminating 'next-day' shipping charges.

VII. Troubleshooting

This section of the Manual has been designed to help identify and correct operational problems. We recommend you use the following guides as a starting point to solve any of the sweeping problems listed.

Each problem is listed with two columns under it. The first one is the 'Cause' column. These are the items most frequently found to occur when the problem listed is present. Across from the 'Cause' column is the 'Solution' column, which contains the steps you should take to correct the problem.

A. MISCELLANEOUS

1. UNUSUAL NOISE OR VIBRATION

CAUSE	SOLUTION
1. Fan out of balance.	1. Clean debris, rebalance or replace fan.
2. Fan shifted within housing.	2. Reposition fan.
3. Loose drive belt.	3. Tighten drive belt.
4. Loose bolts.	4. Tighten bolts.
5. Worn bearing(s).	5. Replace bearing(s).
6. Loose shaft-bearing bolts.	6. Tighten bolts.
7. Fan blades worn or broken.	7. Replace fan.
8. Engine	8. Locate, determine problem, and repair.

2. LOSS OF VACUUM POWER OR SWEEPER NOT PICKING UP

CAUSE	SOLUTION
1. Hopper not fully down/not sealing to fan housing or intake.	1. Lower hopper down and slide forward completely.
2. Sweeping too fast.	2. Slow down.
3. Sweeping hood not fully lowered.	3. Lower hood completely.
4. Sweeping engine throttle position too low.	4. Throttle sweeper engine up.
5. Blocked screen.	5. Remove blockage.
6. Blocked intake valve.	6. Remove blockage.
7. Faulty seal (fan, intake or doors).	7. Replace seal(s).
8. Door blocked open.	8. Open door, clean surfaces, re-close door.
9. Torn hose(s).	9. Replace hose(s).
10. Worn flaps.	10. Adjust side plates or replace flaps.
11. Bent or uneven drag arms.	11. Straighten or replace drag arm.
12. Bent sweeping hood.	12. Replace sweeping hood.
13. Improper hood spring tension.	13. Adjust hood spring tension.
14. Head baffle broken off.	14. Replace baffle.
15. Holes in hopper or fan housing.	15. Repair holes.
16. Loose drive belt.	16. Tighten belt.
17. Worn fan.	17. Replace fan.
18. Low auxiliary engine RPM.	18. Seek service.
19. Fan housing/exhaust door bleeder set wrong.	19. Adjust bleeder.

B. SWEEPING HOOD

1. HOOD NOT GLIDING PROPERLY – EXCESSIVE RUNNER WEAR

CAUSE	SOLUTION
1. Improper hood spring adjustment.	1. Adjust hood spring tension.
2. Bent hood channel.	2. Straighten or replace hood channel.
3. Bent or uneven drag arms.	3. Straighten or replace drag arms.
4. Improper side plate adjustment.	4. Adjust side plates.

2. HOOD DRIFTING DOWN

CAUSE	SOLUTION
1. Leaking sweeping hood cylinder seal.	1. Rework seals or replace cylinder.
2. Check valve stuck open or not functioning.	2. Replace or clean.

C. CURB BROOM

1. BROOM DISC SPINS TOO SLOWLY

CAUSE	SOLUTION
1. Low outside temperature.	1. Run auxiliary engine longer before using broom to warm up hydraulic oil.
2. Sweeper engine throttle position.	2. Throttle up as sweeper engine is too low.
3. Fluid viscosity is too high for operating temperature.	3. Replace with lighter weight oil.
4. Broom hydraulic motor is bad.	4. Rebuild or replace motor.

2. BROOM DISC SPINS TOO FAST

CAUSE	SOLUTION
1. Hydraulic pressure/flow is too high.	1. Adjust hydraulic pressure/flow.

3. DEBRIS TRAILS BETWEEN THE BROOM DISC AND THE SIDE OF THE SWEEPING HOOD

CAUSE	SOLUTION
1. Improper broom head adjustment.	1. Adjust the broom head tilt.

4. BROOM DISC STALLS IN HEAVY DEBRIS

CAUSE	SOLUTION
1. Pressure to the broom motor is too low	1. Adjust pump pressure.
2. Motor or pump seals leaking.	2. Seek service.

5. BROOM FLINGS DEBRIS BACK INTO CURB

CAUSE	SOLUTION
1. The broom disc is adjusted too flat.	1. Adjust broom disc.

6. BROOM FLINGS DEBRIS ACROSS THE STREET

CAUSE	SOLUTION
1. The tilt angle of the broom head is too great.	1. Adjust broom head.

7. BROOM SPINS BUT WILL NOT EXTEND/RETRACT

CAUSE	SOLUTION
1. Inside cylinder hydraulic hose or fitting is blocked.	1. Clear the blockage.
2. Directional valve malfunctioning.	2. Check the directional valve. Replace if needed.

8. BROOM OPERATES BUT WILL NOT LIFT

CAUSE	SOLUTION
1. Mechanical bind.	1. Check broom hardware for binds.
2. Switch or directional valve wire is loose or you have a bad connection.	2. Check the wiring.
3. Leaking cylinder seals (fluid loss out of the port vent).	3. Replace the seals.
4. Blocked solenoid valve.	4. Replace the valve.

9. BROOM SPINS BUT WILL NOT LOWER

CAUSE	SOLUTION
1. Mechanical bind.	1. Check broom hardware for binds.
2. Bad solenoid valve cartridge.	2. Replace cartridge.
3. Solenoid valve electrical circuit incomplete.	3. Complete circuit.

10. BROOM RAISES BUT LEAKS DOWN IMMEDIATELY

CAUSE	SOLUTION
1. Solenoid valve stuck open.	1. Clean valve or replace.
2. Leaking cylinder seals (fluid loss out of the port vent).	2. Replace seals.

11. BROOM DROPS BUT WILL NOT OTHERWISE OPERATE

CAUSE	SOLUTION
1. Bad pump.	1. Service or replace pump.
2. Directional valve electrical circuit incomplete.	2. Complete circuit.
3. Directional valve ports blocked.	3. Seek service.

12. BROOM WILL NOT DROP OR OTHERWISE OPERATE

CAUSE	SOLUTION
1. Bad switch.	1. Replace switch.
2. Circuit breaker tripped.	3. Check circuit breaker and reset if necessary. Otherwise, search for any wiring problem.

D. HYDRAULIC SYSTEM

1. EXTREME HEAT, UNUSUAL NOISE, OR POOR PERFORMANCE FROM THE PUMP

CAUSE	SOLUTION
1. Reservoir cap is not vented.	2. Replace cap with vented equivalent.
2. Low oil level.	2. Check oil and fill as needed.
3. Dirty hydraulic oil.	3. Remove filters and clean or replace. Then change oil.
4. Bad pump.	4. Repair or replace pump.

2. HYDRAULIC SYSTEM WILL NOT OPERATE

CAUSE	SOLUTION
1. Mechanical pump not being powered.	1. Engine must be operating. Determine reason why pump is not being driven and repair.
2. Hydraulic pump pressure low.	2. Adjust pump pressure.
3. Directional valve faulty or it has a poor ground.	3. Check electrical connections or replace valve.
4. No power to auxiliary pump.	4. Complete circuit.
5. Leaking cylinder seals.	5. Replace seals.
6. Major leak in hydraulic system.	6. Repair leak.
7. Internal leak in auxiliary pump.	7. Repair or replace pump.

E. WATER SYSTEM

1. NO WATER EXITING PUMP

CAUSE	SOLUTION
1. Out of water.	1. Refill tank.
2. Suction line clogged.	2. Clean suction strainer.
3. Air leak in line.	3. Tighten plumbing.

2. SPRAY NOZZLE NOT WORKING

CAUSE	SOLUTION
1. Nozzle not on.	1. Switch nozzle on.
2. Clogged nozzle.	2. Clean or replace nozzle.
3. Crimped or clogged water line.	3. Un-crimp or unclog line.
4. No power to pumps.	4. Determine loss of power; complete circuit.

3. LOW PRESSURE

CAUSE	SOLUTION
1. Air leak in inlet plumbing.	1. Disassemble, reseal, and reassemble.
2. Worn nozzle.	2. Replace nozzle.
3. Worn pump.	3. Replace Flow-Jet pump.
4. Other.	4. See water pump Owner's Manual.

Appendix

A. TORQUE REFERENCE CHARTS

The following charts contain torque values that are approximate and should not be accepted as accurate limits. Due to various factors such as, surface finish, type of plating, and lubrication in specific applications preclude the publication of accurate values for universal use.

Manufacturers of various types of equipment usually provide specific tightening instructions that should be followed. DO NOT use the chart values for gasket joints or joints of soft materials.

1. ENGLISH BOLT TORQUE SPECIFICATIONS

MATERIAL/GRADE:	SAE 2 (MILD STEEL)	SOCKET SAE 5 SCREWS	STAINLESS SAE 8 TYPE 303	HEAD CAP	BRASS	AISI
BOLT SIZE						
1/4 - 20	6	11	12	13	5	5
1/4 - 28	7	13	15	16	6	7
5/16 - 18	13	21	25	27	8	9
5/16 - 24	14	23	30	33	9	10
3/8 - 16	23	38	50	52	15	17
3/8 - 24	26	40	60	60	16	18
7/16 - 14	37	55	85	86	23	25
7/16 - 20	41	60	95	95	25	28
1/2 - 13	57	85	125	130	32	37
1/2 - 20	64	95	140	145	34	40
9/16 - 12	80	125	175	180	44	50
9/16 - 18	91	140	195	210	48	54
5/8 - 11	111	175	245	255	68	75
5/8 - 18	128	210	270	290	73	80

2. METRIC BOLT TORQUE SPECIFICATIONS

BOLT DIAMETER		MATERIAL CLASS						
MM	INCH	4.6	4.8	5.8	8.8	9.8	10.9	12.9
5	0.197	3	4	5	7	8	11	12
6	0.236	5	6	8	12.5	14	17	20
6.3	0.248	5.5	8	9.5	14	16	21	24
8	0.315	12	16	20	30	34	44	50
10	0.394	23	32	40	60	70	85	100
12	0.472	40	56	70	103	120	150	180
14	0.551	65	90	110	167	190	240	280
16	0.63	100	140	170	270	290	380	440
18	0.709	137	177	225	350	-	480	580
20	0.787	200	-	330	520	-	740	860

3. TORQUE FOR TIGHTENING SET SCREWS

SET SCREW DIAMETER	HEX SIZE ACROSS FLATS	INCH LB.	FOOT LB.
1/4	1/8	66	5.5
5/16	5/32	126	10.5
3/8	3/16	228	19.0
7/16	7/32	348	29.0
1/2	1/4	504	42.0
5/8	5/16	1104	92.0

4. GENERAL CONVERSION TABLE FOR TORQUE UNITS

Multiply number of	Inches	Inches	Feet	Centimeters	Meters	Newtons
By:	Ounces	Pounds	Pounds	Kilograms	Kilograms	Meters
To obtain:						
Inch Ounces	1.000	16.000	192.000	13.890	1389.000	141.600
Inch Pounds	.062500*	1.000	12.000	0.868	86.800	8.851
Foot Pounds	0.005	.08330**	1.000	0.072	7.233	0.738
Kilogram-Centimeters	0.072	1.152	13.820	1.000	1.000	0.102
Kilogram-Meters	0.001	0.012	0.138	0.010	1.000	0.102
Newton-Meters	0.007	0.113	1.356	0.098	9.807	1.000

*Or divide by 16 **Or divide by 12

EXTENSIONS

Handle extensions (a piece of pipe placed on the wrench in order to make torquing easier) SHOULD NOT BE USED under any circumstances. Their use will result in erroneous torque readings. Over-torquing may snap off bolt heads or cause damage to parts. This practice will also damage the wrench's adjusting mechanism.

While applying torque, the wrench should be held ONLY BY THE GRIP. At high-torque readings, if both hands are necessary to apply enough pressure to achieve the desired torque, hold the grip in one hand and place the other hand on top of the first hand. Never grip the wrench body when using both hands.

5. TORQUE FOR TIGHTENING LOCKING COLLARS

CAP SCREW DIAMETER	HEX SIZE ACROSS FLATS	INCH LB.	FOOT LB.
#8-32 UNC-3 A	1/8	70	5.8
#10-24 UNC-3 A	9/64	90	7.5
#1/4-20 UNC-3 A	3/16	180	15.0
#5/16-18 UNC-3 A	1/4	400	33.3



Galaxy R-4

Parts Section

To Order:

Call Toll Free: 800.482.2302

Call Direct: 717.564.5600

(7 AM to 5 PM, Eastern)

Send Fax: 717.901.2326

(24/7/365)

Email: parts@stewart-amos.com

CONSOLE ASSEMBLY

EXPLODED VIEW

PART #300253

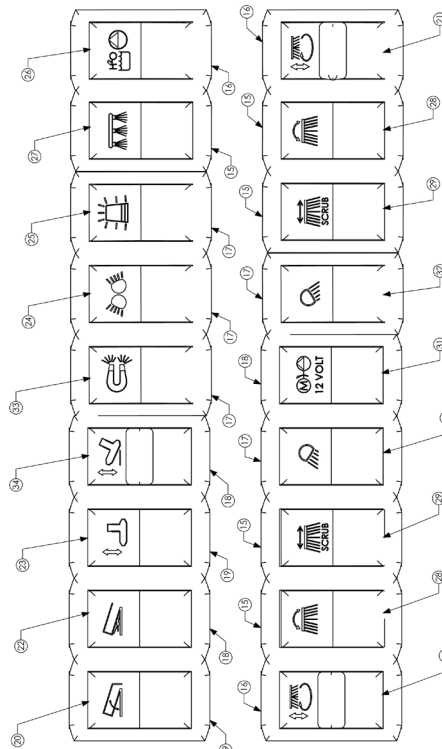
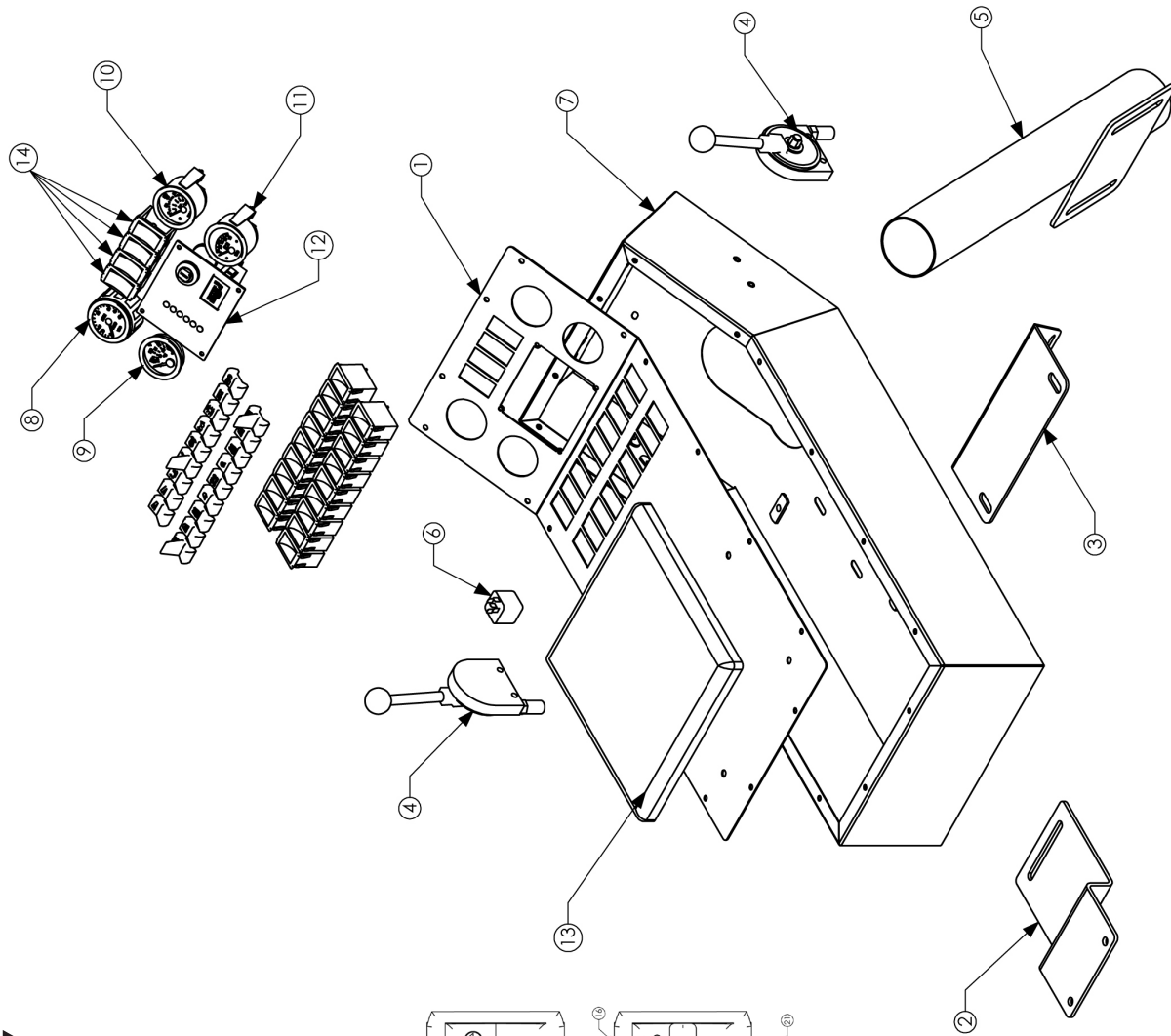

CONSOLE ASSEMBLY

PARTS REQUIREMENTS

ITEM NO.	QTY.	PART NUMBER	DESCRIPTION
1	1	2001091	CONSOLE TOP W/O JOYSTICK R4/R6
2	1	2001094	NEW CONSOLE REAR MOUNT BRACKET R6
3	1	2000210	FRONT UPPER CONSOLE MOUNT
4	2	50145	THROTTLE CABLE ASSY
5	1	200279	FRONT MOUNTING TUBE CONSOLE R4/R6
6	1	50674	POWER SOURCE RELAY
7	1	200277	CONSOLE BASE R6
8	1	51140	TACHOMETER GAUGE
9	1	51141	TEMPERATURE GAUGE
10	1	51142	OIL GAUGE
11	1	51143	VOLT METER GAUGE
12	1	51177	CONTROL MODULE ENGINE SHUTDOWN
13	1	2001106	ARM REST PAD CONSOLE R4\R6
14	4	51181	SWITCH, LH2-HOLE PLUG W/ SERRATED WINGS
15	5	51161	SWITCH, ROCKER DPDT (O)-F-(O)
16	3	51162	SWITCH, ROCKER DPDT O-F-(O)

ITEM NO.	QTY.	PART NUMBER	DESCRIPTION
17	5	51160	SWITCH, ROCKER SPST O-F
18	3	51175	SWITCH, ROCKER SPST (O)-F
19	2	51172	SWITCH, ROCKER DPDT (O)-F-(O)
20	1	51153	SWITCH ACTUATOR DUMP
21	2	51152	SWITCH ACTUATOR GUTTER BROOM
22	1	51155	SWITCH ACTUATOR HOPPER SHAKER
23	1	51154	SWITCH ACTUATOR HEAD UP/DOWN
24	1	51157	SWITCH ACTUATOR HOOD LIGHTS
25	1	51158	SWITCH ACTUATOR BEACON
26	1	51159	SWITCH ACTUATOR WATER SYSTEM
27	1	51166	SWITCH ACTUATOR SPRAY BAR
28	2	51167	SWITCH ACTUATOR G/B TILT
29	2	51168	SWITCH ACTUATOR SCRUB IN/OUT
30	1	51169	SWITCH ACTUATOR LEFT G/B LIGHT
31	1	51170	SWITCH ACTUATOR 12 VOLT DC PUMP
32	1	51171	SWITCH ACTUATOR RIGHT G/B LIGHT
33	1	51173	SWITCH ACTUATOR MAGNETIC BAR
34	1	51174	SWITCH ACTUATOR HEAD JUMP

MAIN FRAME ASSEMBLY

EXPLODED VIEW PART #300207

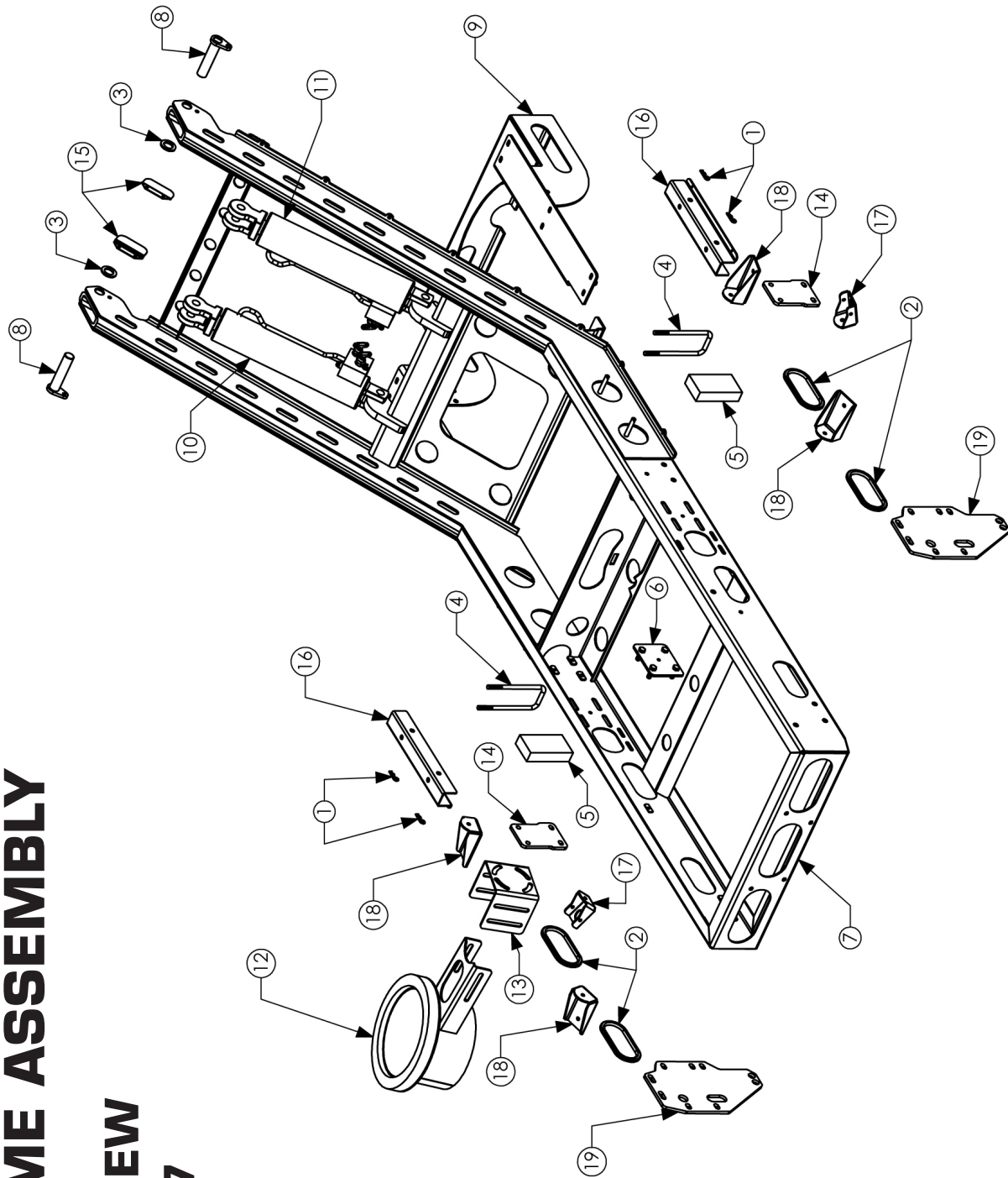

MAIN FRAME ASSEMBLY

PARTS REQUIREMENTS

ITEM NO.	PART NUMBER	DESCRIPTION	Default/QTY.
1	50077	HAIR PIN COITER 0.148	4
2	50244-017	RUBBER EDGE TRIM 1.7"	4
3	50246	FRAME WASHER 3\16 X 2.00 OD	2
4	50581	REAR TIE DOWN U-BOLT FRAME	2
5	50667	WOODEN BLOCK (2 X 4 X 6-7/16")	2
6	200011	BOLT PLATE TRANSITION	1
7	200012	MAIN FRAME WELDMENT	1
8	200026	HOPPER HINGE PIN WELDMENT	2
9	200044	REAR BUMPER MOUNTING BRACKET	1
10	300034	LH DUMP CYLINDER ASSY	1
11	300035	RH DUMP CYLINDER KIT	1
12	300215	R4 INTAKE TRANSITION TUBE ASSEMBLY	1
13	2000118	TRANSITION MOUNTING BRACKET	1
14	2000119	MIDDLE TIE DOWN MAIN FRAME	2
15	2000199	CAP HOPPER HINGE PIN	2
16	2000218	SAFETY CHAULK HOPPER DUMP	2
17	2000223	HEAD SPRING HANGER	2
18	2000335	HEAD SPRING HANGER (NEW 11/07)	4
19	2000929	DRAG ARM BRACKET 2009 GMC W4500	2

INTAKE TRANSITION TUBE ASSEMBLY

EXPLODED VIEW
PART #300215

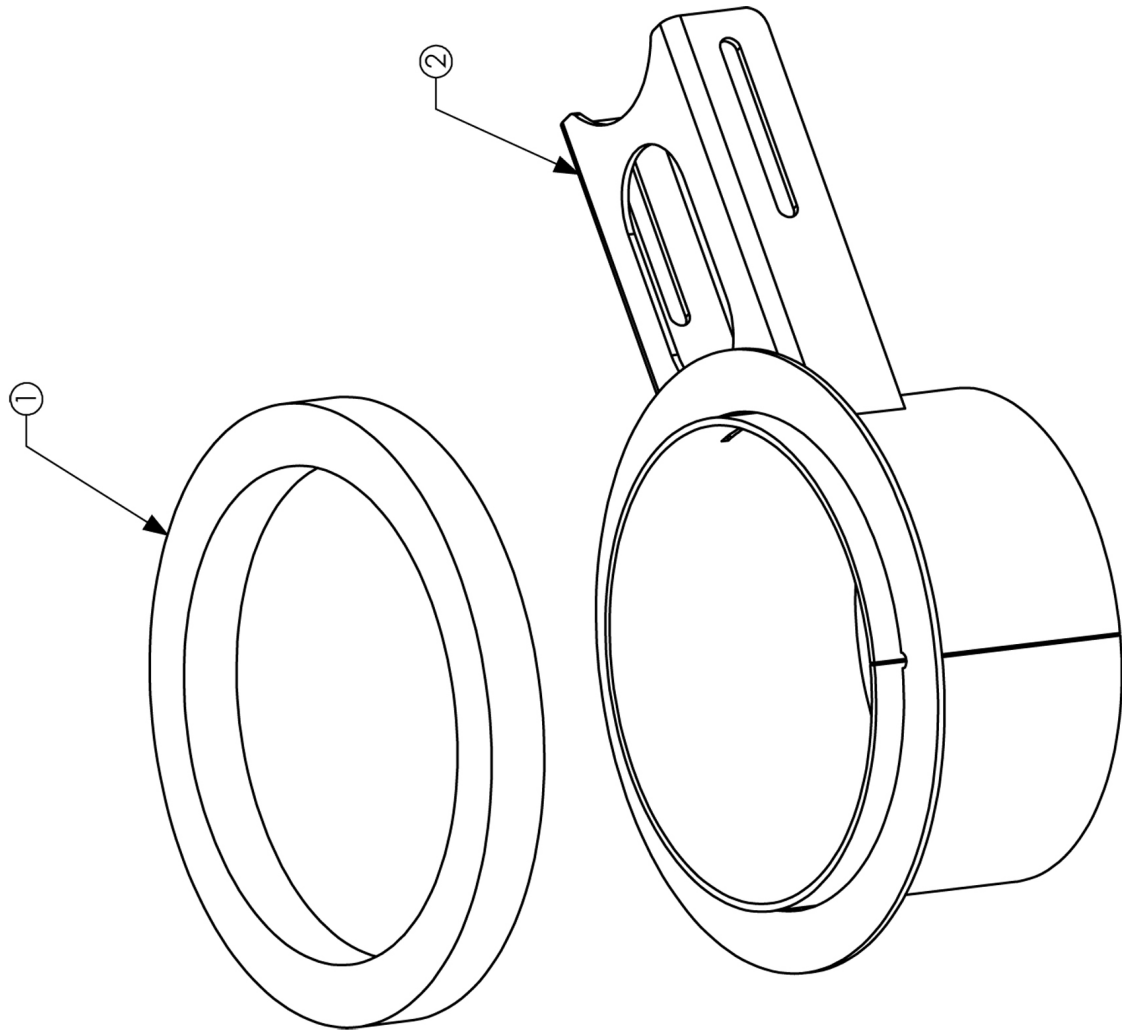

INTAKE TRANSITION TUBE ASSEMBLY

PARTS REQUIREMENTS

ITEM NO.	PART NUMBER	DESCRIPTION	QTY.
1	24046	HOPPER INTAKE TUBE SEAL A4000\S348LE	1
2	200230	R4 INTAKE TRANSITION TUBE WELDMENT	1

LEFT SIDE DUMP CYLINDER MODULE

EXPLODED VIEW

PART #300034

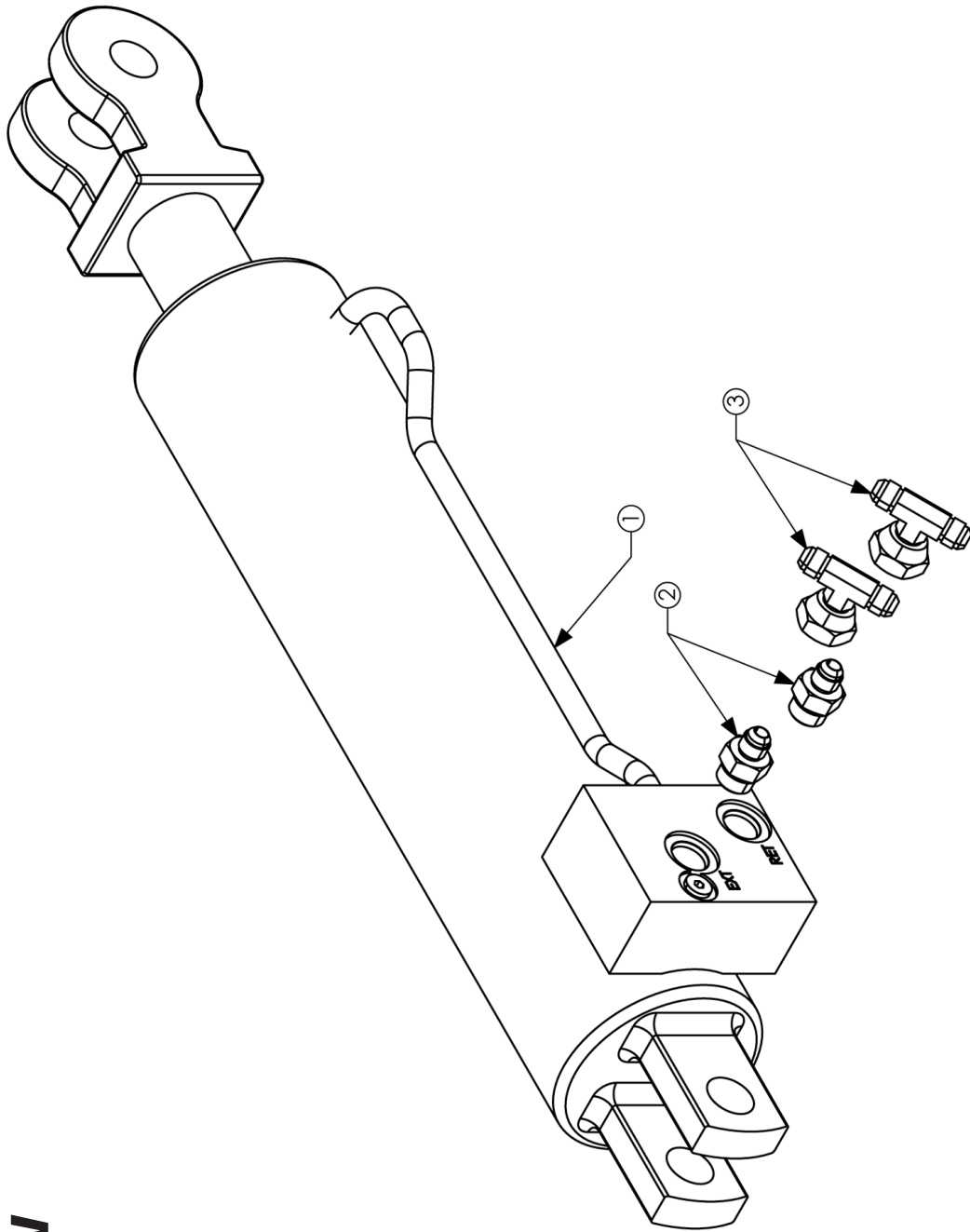

LEFT SIDE DUMP CYLINDER MODULE

PARTS REQUIREMENTS

ITEM NO.	QTY.	PART NUMBER	DESCRIPTION
1	1	50009	HYD CYL 4 x 16
2	2	50648	6-8 F50X
3	2	50909	TEE, 3\8" SWIVEL NUT RUN

RIGHT SIDE DUMP CYLINDER

EXPLODED VIEW

PART #300035

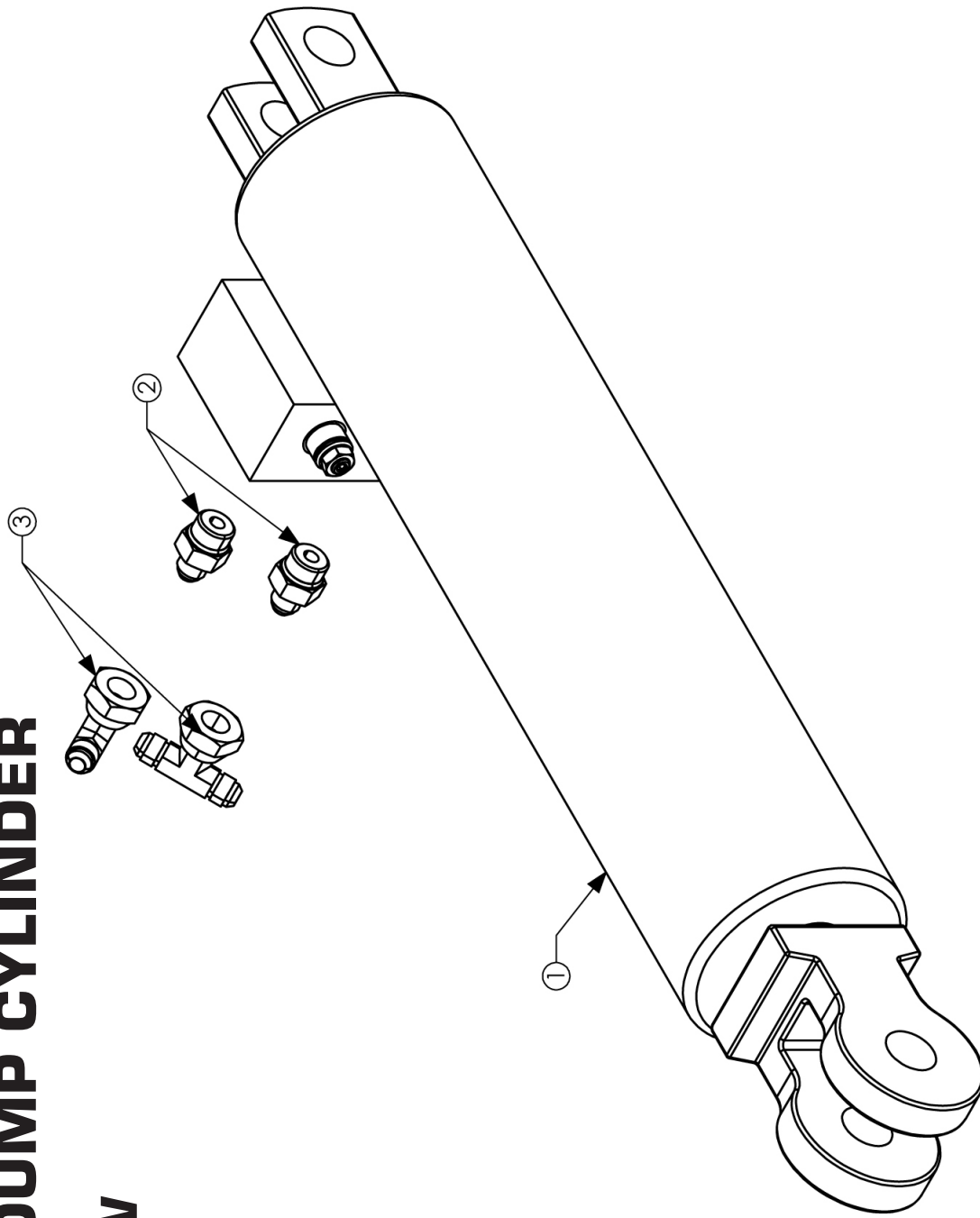

RIGHT SIDE DUMP CYLINDER PARTS REQUIREMENTS

ITEM NO.	QTY.	PART NUMBER	DESCRIPTION
1	1	50009	HYD CYL 4 x 16
2	2	50648	6-8 F50X
3	2	50909	TEE 3/8" SWIVEL NUT RUN

REAR BUMPER ASSEMBLY

EXPLODED VIEW PART #300010

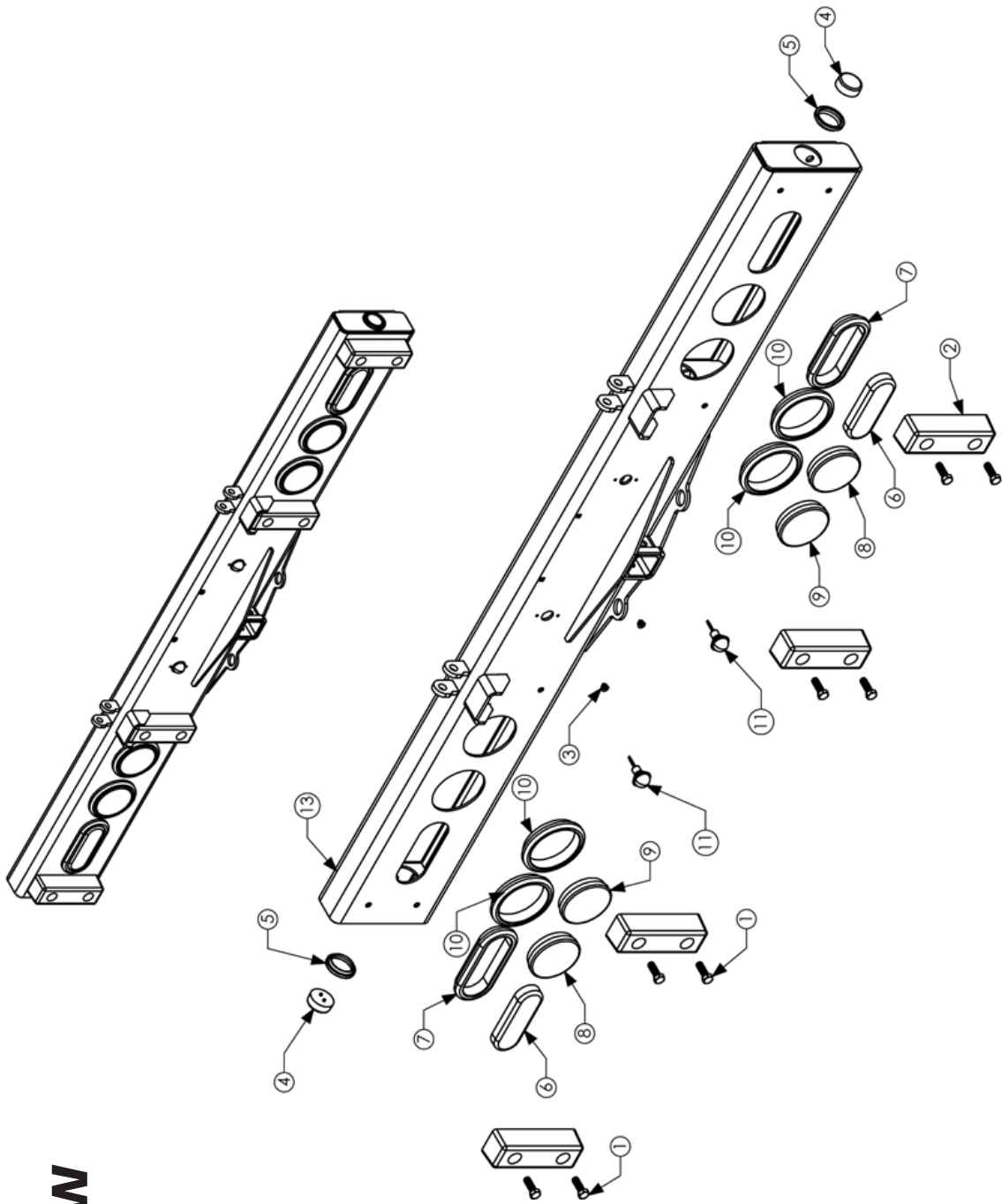

REAR BUMPER ASSEMBLY

PARTS REQUIREMENTS

ITEM NO.	QTY.	PART NUMBER	DESCRIPTION
1	8	40000	SCREW HHCS 1/2-13 X 1-1/2 G5
2	4	50035	RUBBER BUMPER T-42
3	2	50047	SCREW RECEPTACLE
4	2	50136	2" RED CLEARANCE LIGHT
5	2	50137	2" MOUNTING GROMMET LIGHT
6	2	50139	RED OVAL LED TAIL LIGHT 6-1\2
7	2	50140	OVAL LIGHT GROMMET 6-1\2"
8	2	50141	4" ROUND AMBER LED LIGHT T\S
9	2	50142	4" ROUND CLEAR LED LIGHT T\S
10	4	50143	4" ROUND LIGHT GROMMET
11	2	50144	TAG LIGHT V432
12	1	50764	BUMPER WIRING HARNESS
13	1	200029	REAR BUMPER WELDMENT

POWER MODULE ASSEMBLY

EXPLODED VIEW PART #300211

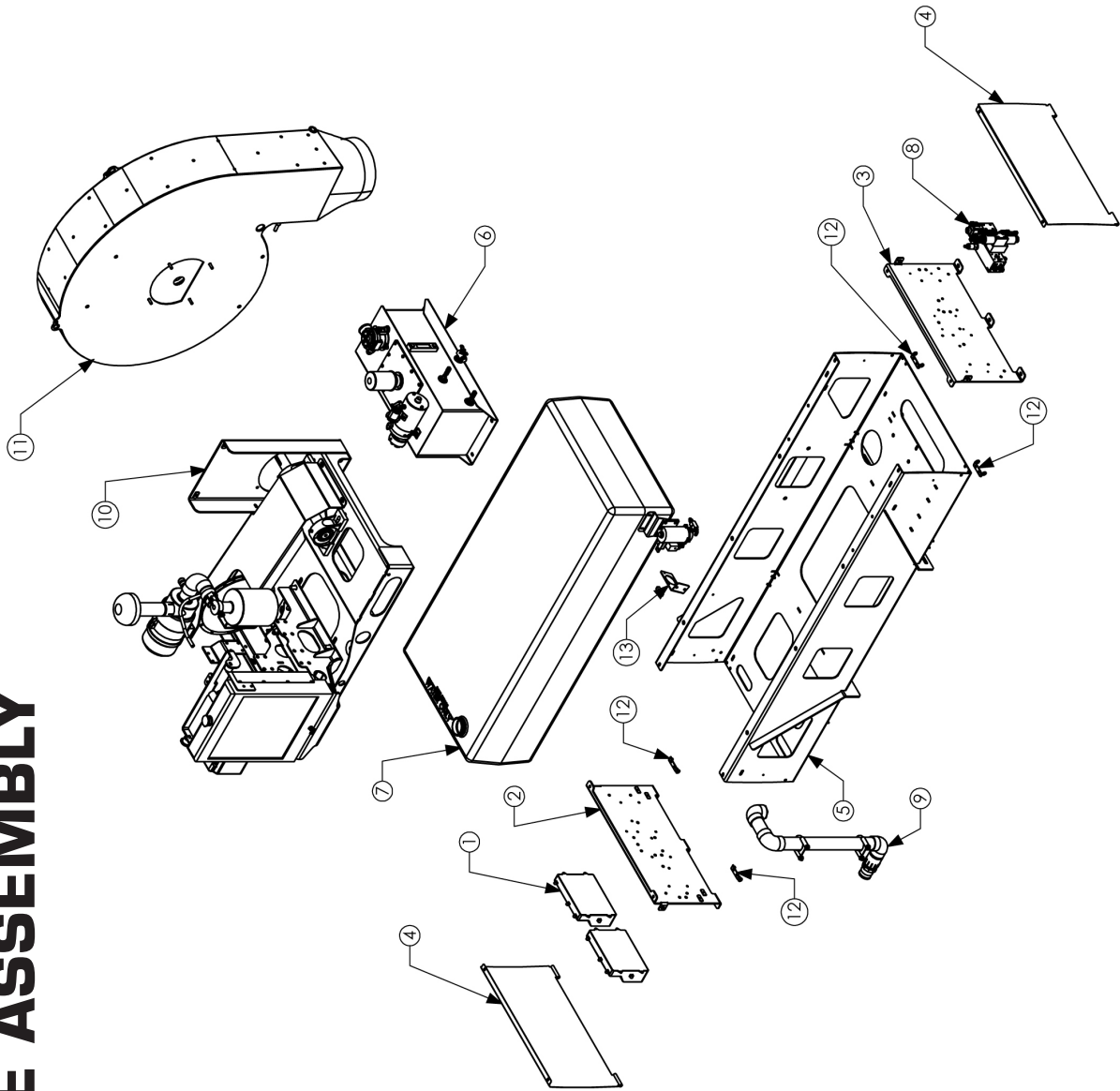

POWER MODULE ASSEMBLY

PARTS REQUIREMENTS

ITEM NO.	PART NUMBER	DESCRIPTION	QTY.
1	50065	ECP CONTROL CENTER	2
2	200010	ECP MOUNTING PLATE PM	1
3	200046	HYD MANIFOLD MOUNT PLATE PM	1
4	200069	COVER DOOR POWER MODULE	2
5	200232	R4 POWER MODULE WELDMENT	1
6	300003	HYDRAULIC RESERVOIR ASSY MK II	1
7	300020	WATER SYSTEM ASSY STD	1
8	300194	STANDARD MANIFOLD ASSY LIBERTY	1
9	300202	HYDRANT FILL TUBE ASSEMBLY	1
10	300210	R4 ENGINE SKID	1
11	300212	R4 FAN HOUSING ASSEMBLY	1
12	2000178	HINGE PLATE LOWER DOOR PM	4
13	2000963	R4 FUEL FILLER BRACKET POWER MODULE	1
14	2000830	FAN SHAFT PULLEY LOCK KEY	1

**ENGINE SKID
EXPLODED VIEW
PART #300210**

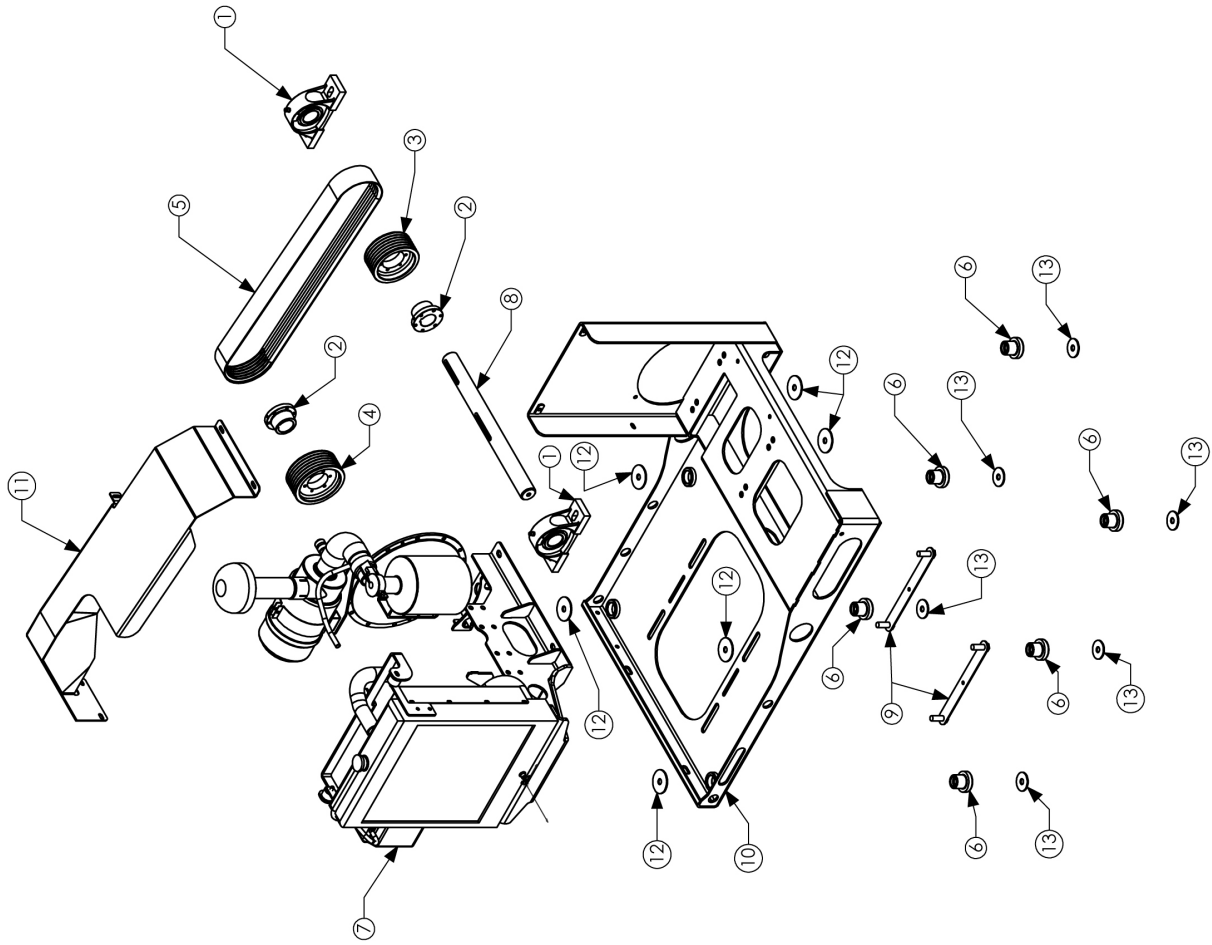

ENGINE SKID

PARTS REQUIREMENTS

ITEM NO.	PART NUMBER	DESCRIPTION	QTY.
1	50031	BEARING MP-31T	2
2	50061	BUSHING SK 1-15\16	2
3	50678	PULLEY 6\3V600 SK	1
4	50679	PULLEY 6\3V650 SK	1
5	50804	BELT 6\3V750	1
6	51045	VIBRATION ISOLATOR CENTER BONDED	6
7	51119	ENGINE ASSY 3024CT AOV DIESEL	1
8	51298	R4 FAN SHAFT 21-1\4"	1
9	200009	SLIDE BAR ENGINE SKID 3024CT	2
10	200233	R4 ENGINE\BEARING TRAY W\ISOLATORS	1
11	2000969	BELT GUARD R4	1
12	2000781	HEAD WASHER ENGINE SKID	6
13	2000782	TAIL WASHER ENGINE SKID	6

HYDRAULIC PUMP ASSEMBLY TIER III; SINGLE BROOM EXPLODED VIEW PART #300240

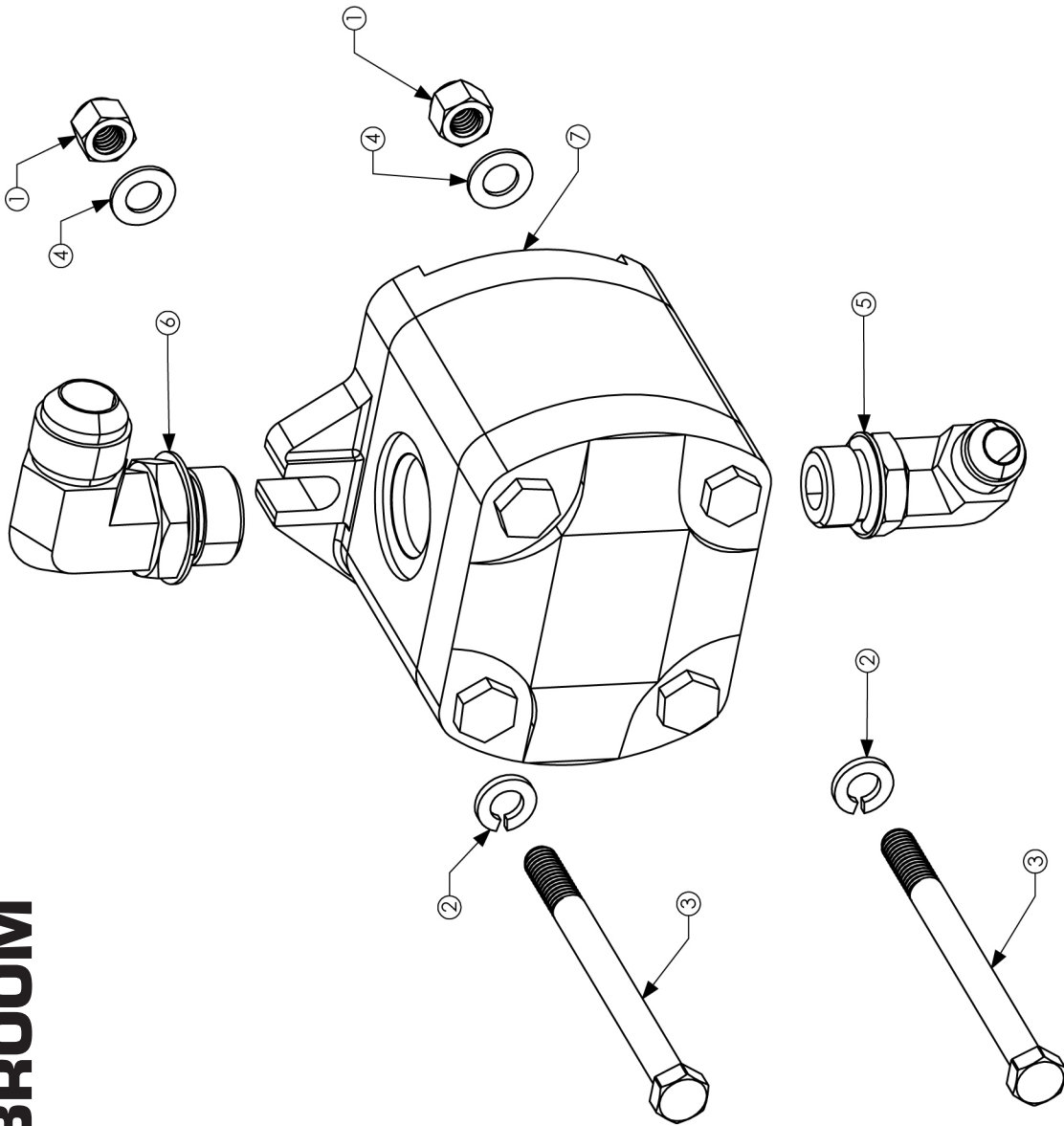

HYDRAULIC PUMP ASSEMBLY TIER III; SINGLE BROOM

PARTS REQUIREMENTS

ITEM NO.	PART NUMBER	DESCRIPTION	QTY.
1	40013	NUT LOC 3/8-16	2
2	40027	WASHER SPRING LOCK 3/8"	2
3	40287	3/8-16 X 4-1/2 HEX HEAD CAP SCREW GR5Z	2
4	40447	3/8 WASHER ZINC	2
5	50430	ELBOW 90° 1/2 MJIC X 5/8 SAE	1
6	50567	ELBOW 90, 3/4" MJIC X 3/4" SAE	1
7	51088	PUMP GEAR .79 CU IN	1

HYDRAULIC PUMP ASSEMBLY TIER III; DUAL BROOM

EXPLODED VIEW PART #300241

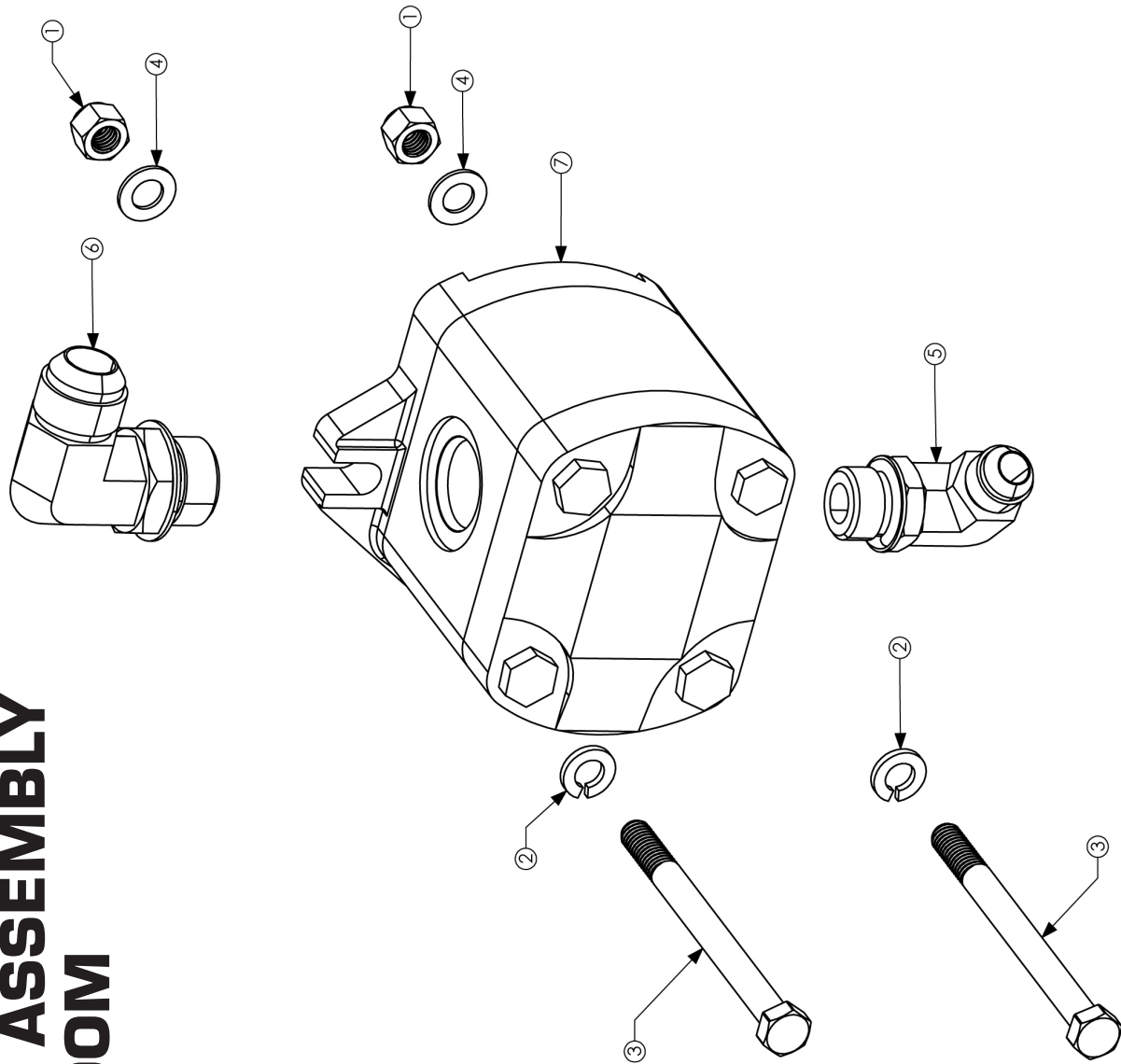

HYDRAULIC PUMP ASSEMBLY TIER III; DUAL BROOM

PARTS REQUIREMENTS

ITEM NO.	PART NUMBER	DESCRIPTION	QTY.
1	40013	NUT LOC 3/8-16	2
2	40027	WASHER SPRING LOCK 3/8"	2
3	40287	3/8-16 X 4-1/2 HEX HEAD CAP SCREW GR5Z	2
4	40447	3/8 WASHER ZINC	2
5	50430	ELBOW 90° 1/2 MJIC X 5/8 SAE	1
6	50567	ELBOW 90, 3/4" MJIC X 3/4" SAE	1
7	51088	PUMP GEAR .79 CU IN	1

MANIFOLD SINGLE BROOM

EXPLODED VIEW

PART #50052

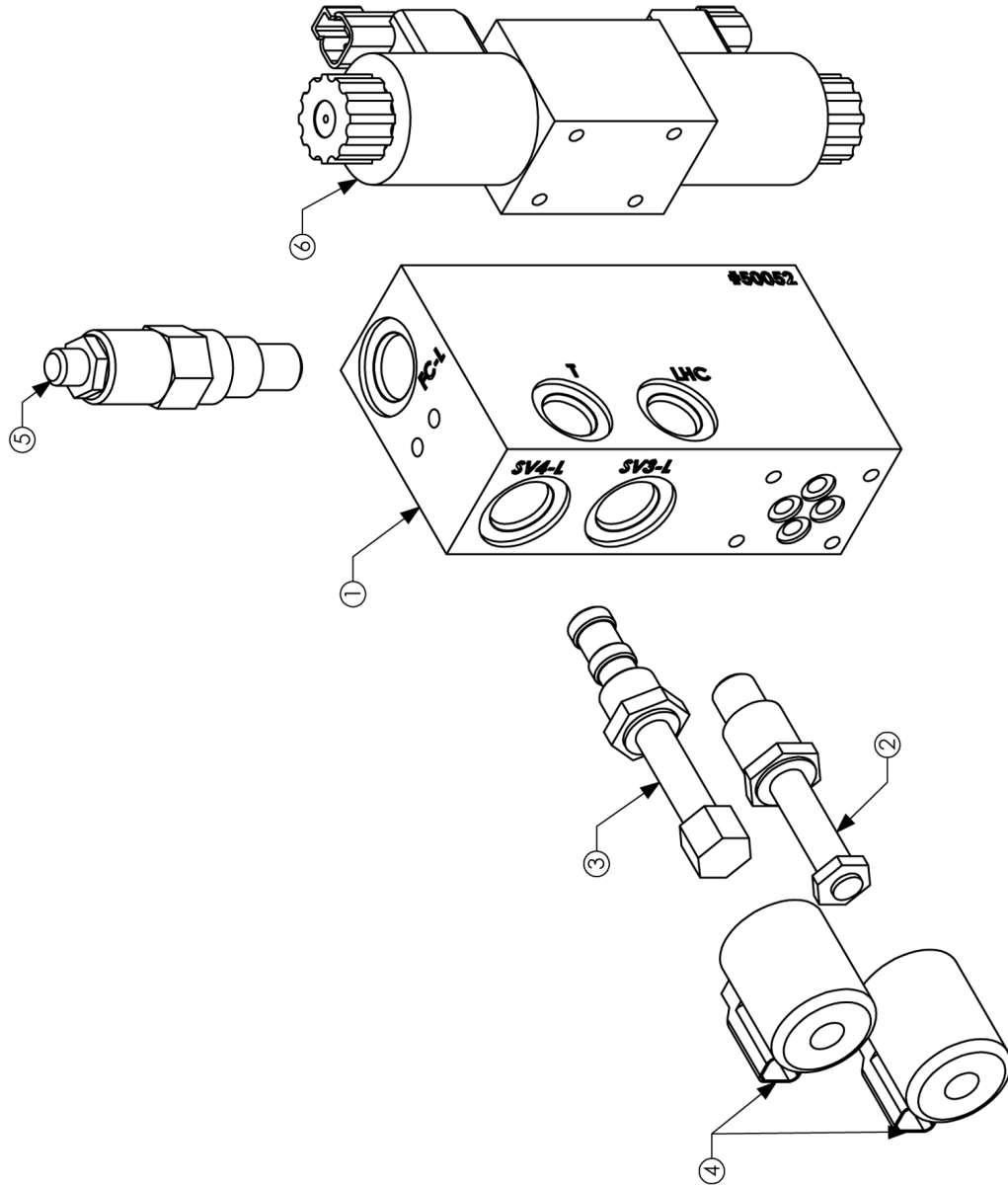

MANIFOLD SINGLE BROOM

PARTS REQUIREMENTS

ITEM NO.	PART NUMBER	QTY.	DESCRIPTION
1	50052	1	MANIFOLD SINGLE BROOM ADD-ON
2	50146	1	SOLENOID VALVE SV3-10-C-0-00
3	50147	1	VALVE SV4-10-3-0-00
4	50154	2	COIL MCSCJ012DN000010
5	50318	1	CHECK VALVE FR2-10-S-0-/5.50
6	50123	1	DIRECTIONAL VALVE D03

HYDRAULIC RESERVOIR ASSEMBLY

EXPLODED VIEW PART #300003

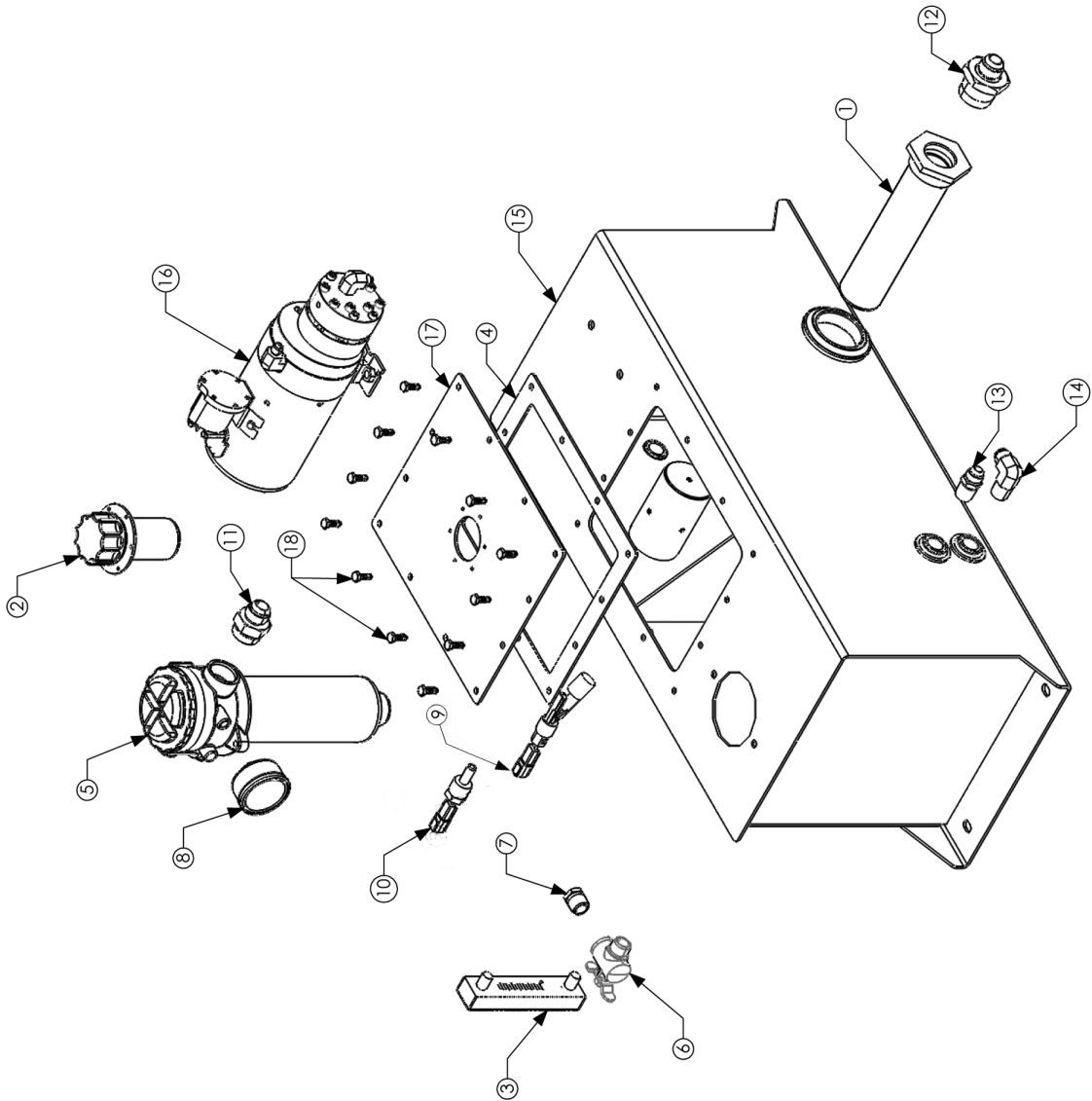

HYDRAULIC RESERVOIR ASSEMBLY

PARTS REQUIREMENTS

ITEM NO.	QTY.	PART NUMBER	DESCRIPTION
1	1	50036	SUCTION STRAINER S-25-100
2	1	50037	FILLER \BREAHER MBR120
3	1	50040	SIGHT GAUGE SNA 127112
4	1	50041	GASKET HYD RESERVOIR
5	1	50042	RETURN FILTER HYD RESERVOIR OFMT100
6	1	50055	VALVE 1 1/2" 90° XV590P-8
7	1	50089	1 1/2 NPT BRASS PLUG HH
8	1	50321	GAUGE INDICATOR HYD RETURN FILTER
9	1	50414	HYD. FLUID LEVEL SENSOR
10	1	50418	TEMPERATURE SWITCH / NASON
11	1	50569	CONNECTOR 3/4" MJIC X 1" SAE
12	1	50573	CONNECTOR 3/4 MJIC X 1 MNPT
13	1	50686	CONNECTOR, 1 1/2 MJIC X 1 1/2 NPT
14	1	50735	ELBOW 90 1/2 MJIC X 1/2 MNPT
15	1	200007	HYD RESERVOIR WELDMENT 16 GAL
16	1	300052	12 VDC AUX HYD PUMP ASSY
17	1	2000013	INSPECTION COVER HYD TANK
18	12	40003	SCREW HHSC 1/4-20 X 3/4 G5

12-VOLT AUXILIARY HYDRAULIC PUMP ASSEMBLY

**EXPLODED VIEW
PART #300052**

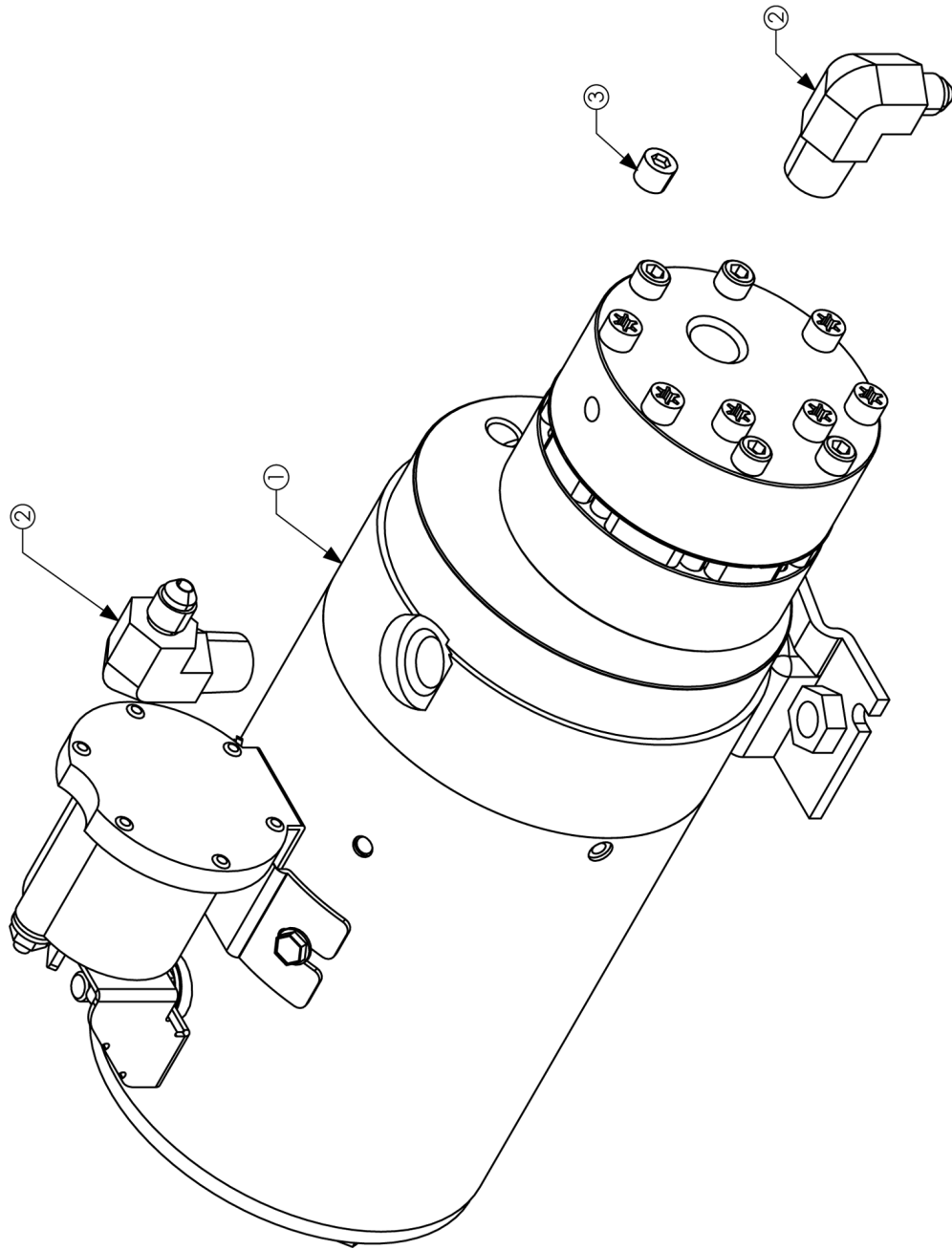

12-VOLT AUXILIARY HYDRAULIC PUMP ASSEMBLY

PARTS REQUIREMENTS

ITEM NO.	QTY.	PART NUMBER	DESCRIPTION
1	1	50170	12 VDC AUX HYD PUMP
2	2	50650	ELBOW 1/4 MJIC x 3/8 MNPT
3	1	50734	PLUG 1/8 HOLLOW HEX PIPE NPTF

12-VOLT WATER SYSTEM ASSEMBLY

EXPLODED VIEW
PART #300020

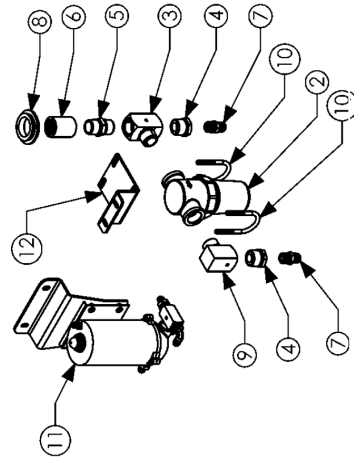
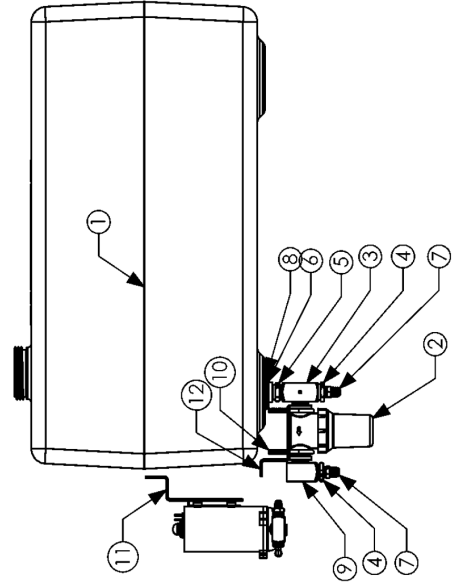
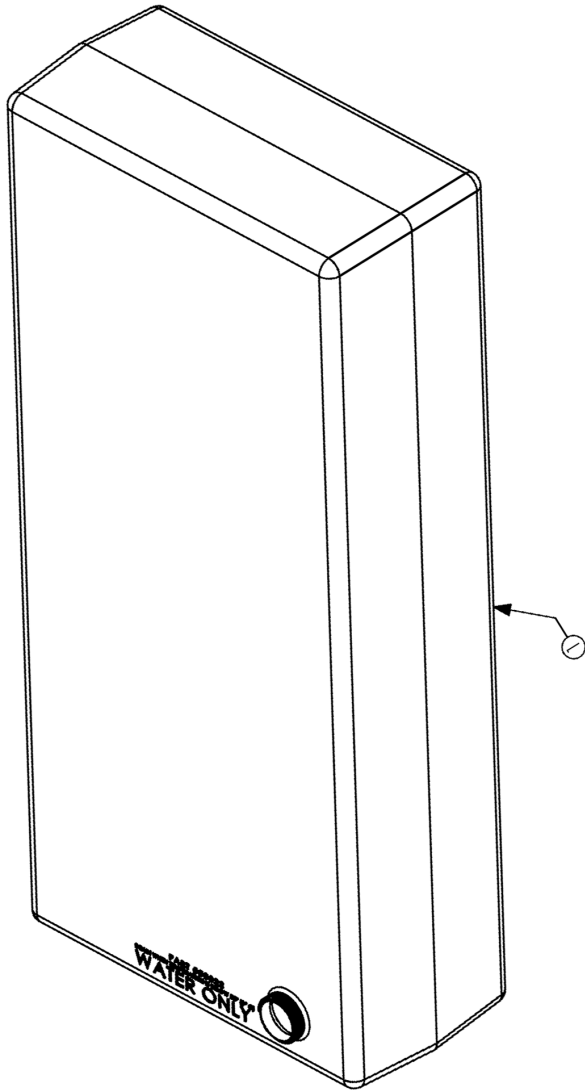

12-VOLT WATER SYSTEM ASSEMBLY

PARTS REQUIREMENTS

ITEM NO.	QTY.	PART NUMBER	DESCRIPTION
1	1	50022	WATER RESERVOIR 127 GAL
2	1	50072	STRAINER ASSY 80 MESH
3	1	50087	TEE MALE BRANCH 3/4 BRASS
4	2	50093	3/4 X 3/8 BRASS BUSHING
5	1	50095	3/4 BRASS HEX NIPPLE
6	1	50096	3/4 GALVANIZED COUPLING
7	2	50102	CONNECTOR 3/8 NPT X 45° FLARE BRASS
8	1	50103	1" UNISEAL GROMMET
9	1	50105	ELBOW 3/4 STREET 90°
10	2	50291	U-BOLT 1/4-20 X 2-3/4 X 1-1/2
11	1	300013	12V WATER PUMP ASSY
12	1	2000121	WATER FILTER BRACKET PM

12-VOLT WATER PUMP ASSEMBLY

EXPLODED VIEW PART #300013

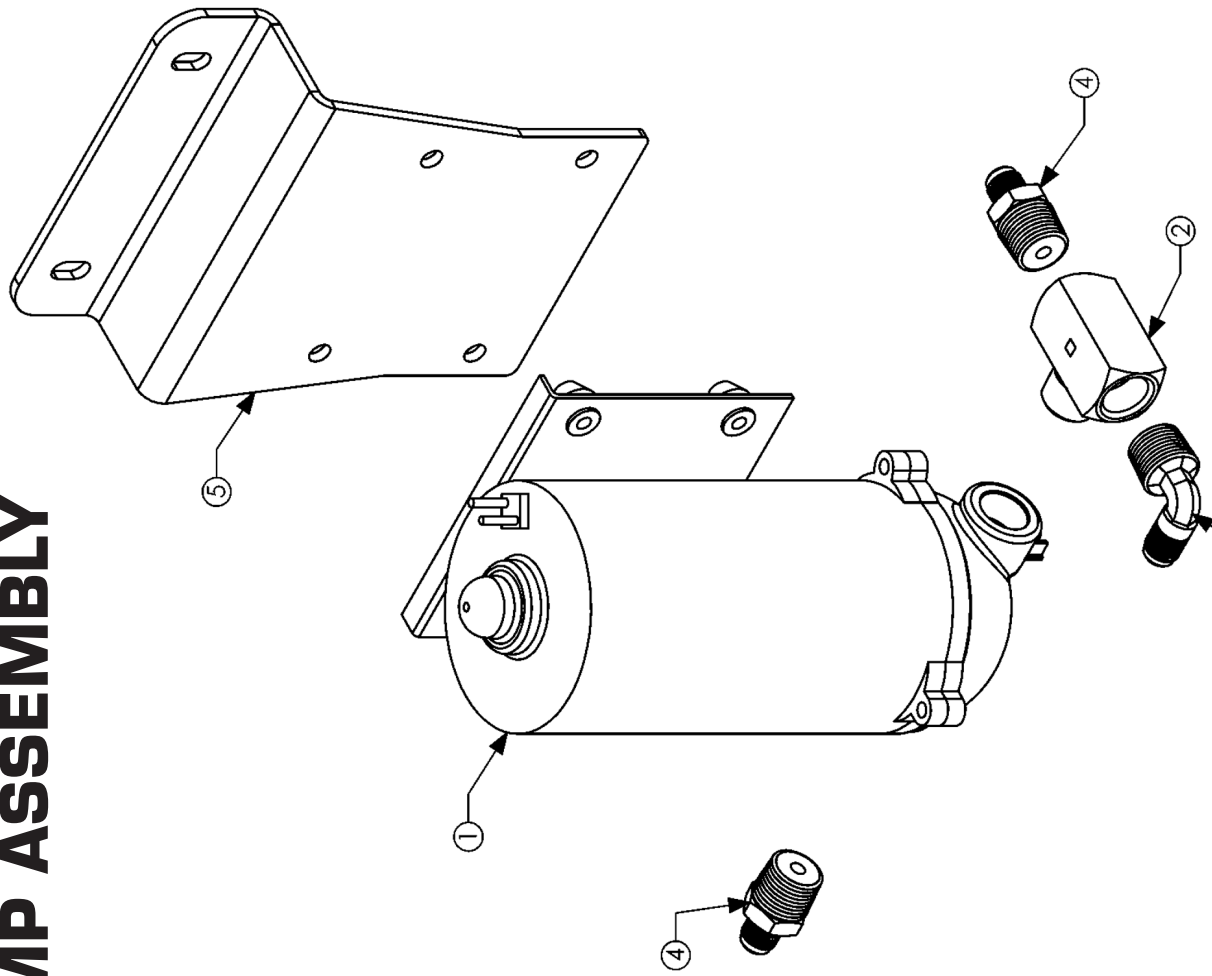

12-VOLT WATER PUMP ASSEMBLY

PARTS REQUIREMENTS

ITEM NO.	QTY.	PART NUMBER	DESCRIPTION
1	1	50068	WATER PUMP 12 VDC
2	1	50110	TEE 3\8 MALE BRANCH BRASS
3	1	50757	ELBOW, 90° 1\4" FLARE X 3\8 NPT
4	2	50758	CONNECTOR, 1\4" FLARE X 3\8 NPT
5	1	2000120	12V WATER PUMP BRACKET

FAN HOUSING ASSEMBLY

EXPLODED VIEW

PARTS #300212

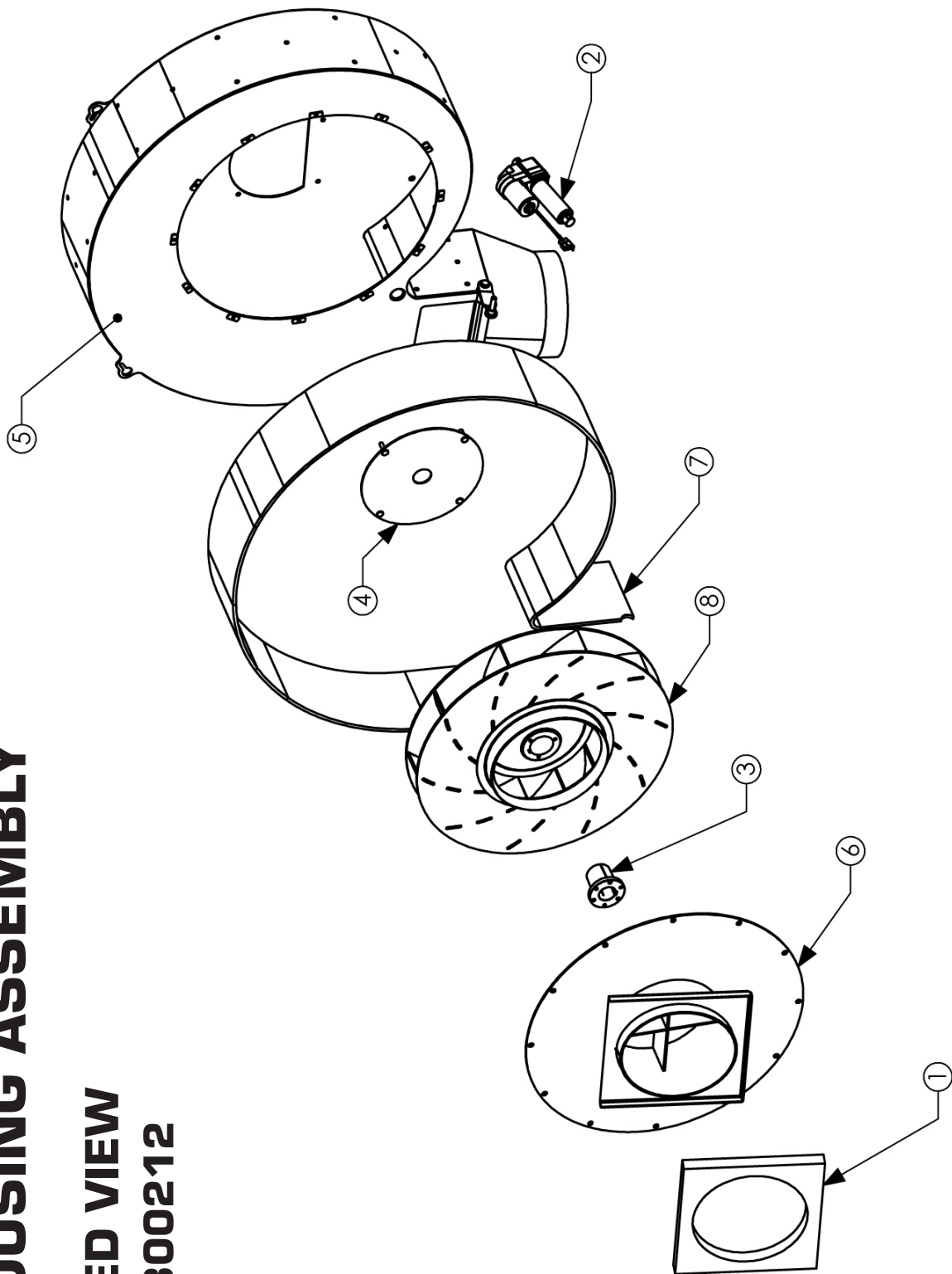

FAN HOUSING ASSEMBLY

PARTS REQUIREMENTS

ITEM NO.	PART NUMBER	DESCRIPTION	Default/Qty
1	21440	FAN SEAL S333/S343/S3471 PRE 2000	1
2	50025	ACTUATOR 4" 1200 LB	1
3	50064	BUSHING Q2 1-15\16	1
4	200002	PORT COVER FAN HOUSING	1
5	200234	R4 FAN HOUSING 30in	1
6	200006	BACKPLATE FAN HOUSING	1
7	300012	LINER KIT FAN HOUSING	1
8	600004	FAN 30" S-SERIES REPLACEMENT	1
9	2000966	TRANSITION TUBE R4 HOUSING	1

FAN HOUSING LINER KIT

EXPLODED VIEW

PART #300012

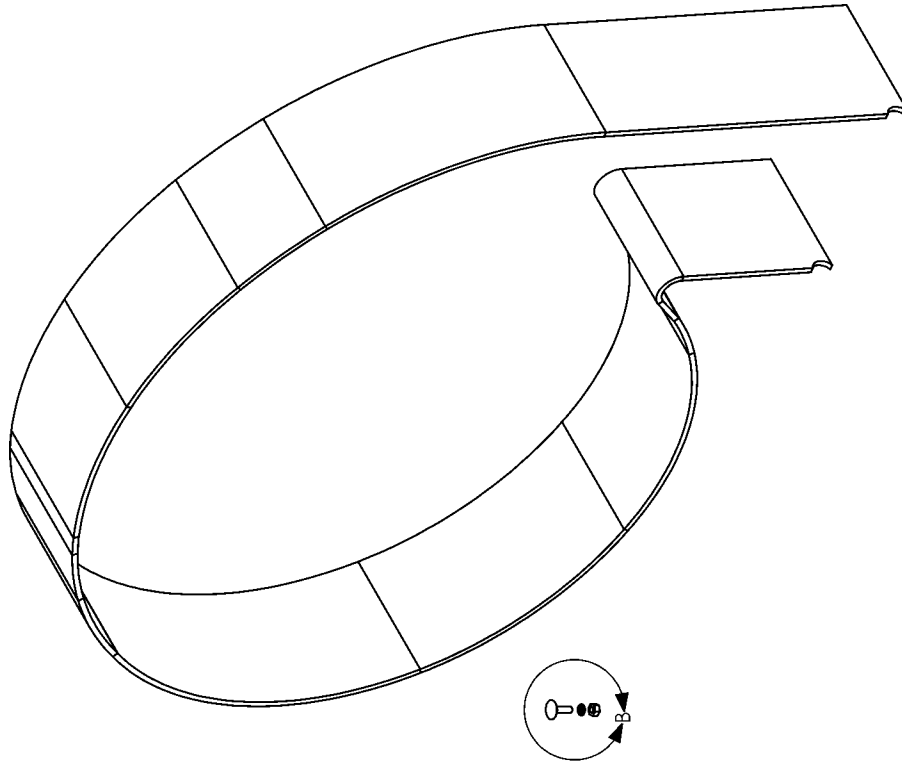

300012 LINER KIT BOM

- (40) 3/8 X 1-1/4 ELEVATOR BOLTS
- (40) 3/8 LOCK WASHERS
- (40) 3/8 HEX NUTS
- (1) 2000192 RUBBER LINER
- (1) TUBE OF CLEAR SILICONE

NOTE: APPLY A GENEROUS LAYER OF SILICONE TO ALL BOLT HEADS AND TO EACH SIDE OF THE LINER TO FILL IN THE GAP BETWEEN THE HOUSING

**DETAIL B
SCALE 1 : 2**

FAN HOUSING LINER KIT

PARTS REQUIREMENTS

ITEM NO.	QTY.	PART NUMBER	DESCRIPTION
1	40	40027	WASHER SPRING LOCK 3/8"
2	40	40028	HEX NUT 3/8"
3	40	40056	ELEVATOR BOLT 3/8 X 1-1/2"
4	1	2000192	RUBBER LINER FAN HOUSING

COMPLETE HOPPER ASSEMBLY

EXPLODED VIEW PART #300208

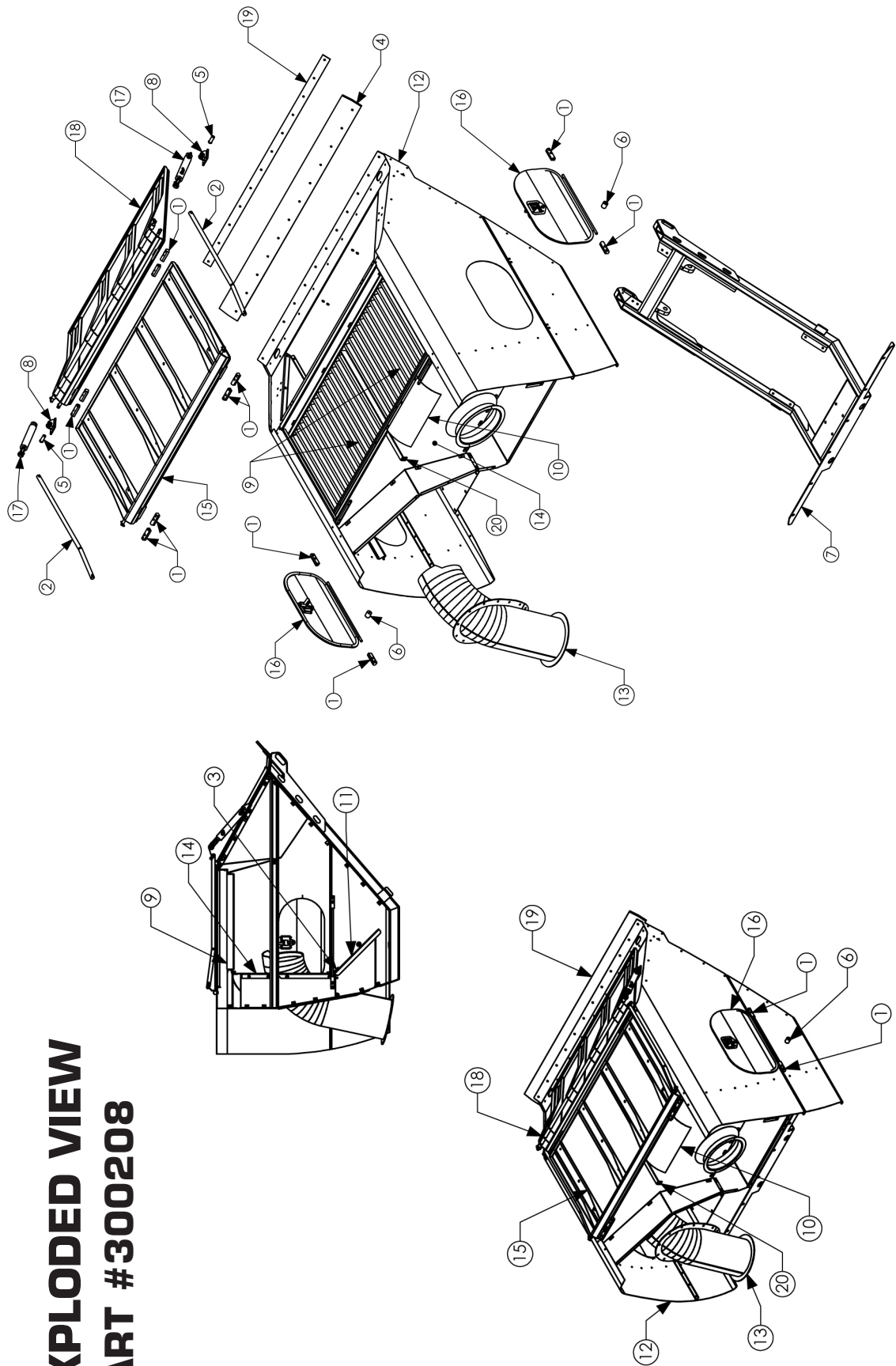

COMPLETE HOPPER ASSEMBLY

PARTS REQUIREMENTS

ITEM NO.	PART NUMBER	DESCRIPTION	QTY.
1	50012	SCROLL HOPPER SEPARATOR	1
2	50044	SS WELD NUT 3\8-16 NDZ-3324	16
3	50076	SS WELD NUT 5\16 NDZ-2724	8
4	2000071	HOPPER TAIL PLATE	1
5	2000074	LH DUMP GUSSET HOPPER	1
6	2000075	RH DUMP GUSSET HOPPER	1
7	2000076	LH TOP RIB HOPPER	1
8	2000078	RH UPPER RIB HOPPER	1
9	2000081	LOWER BASIN SEPARATOR HOPPER	1
10	2000241	BOLT PLATE HOPPER DOOR HINGES	4
11	2000242	BOLT PLATE DUMP DOOR CYLINDER	2
12	2000257	LH LOWER HOPPER SIDE	1
13	2000258	LH UPPER HOPPER SIDE	1
14	2000259	RH LOWER SIDE HOPPER	1
15	2000260	RH UPPER SIDE HOPPER	1
16	2000944	R4 HOPPER SEAL PLATE	1
17	2000945	R4 REAR HOPPER PAN	1
18	2000946	R4 FRONT HOPPER PAN	1
19	2000947	R4 RH SEPARATOR WRAP HOPPER	1
20	2000948	R4 LH SEPARATOR WRAP HOPPER	1

HOPPER ASSEMBLY

EXPLODED VIEW PART #200259

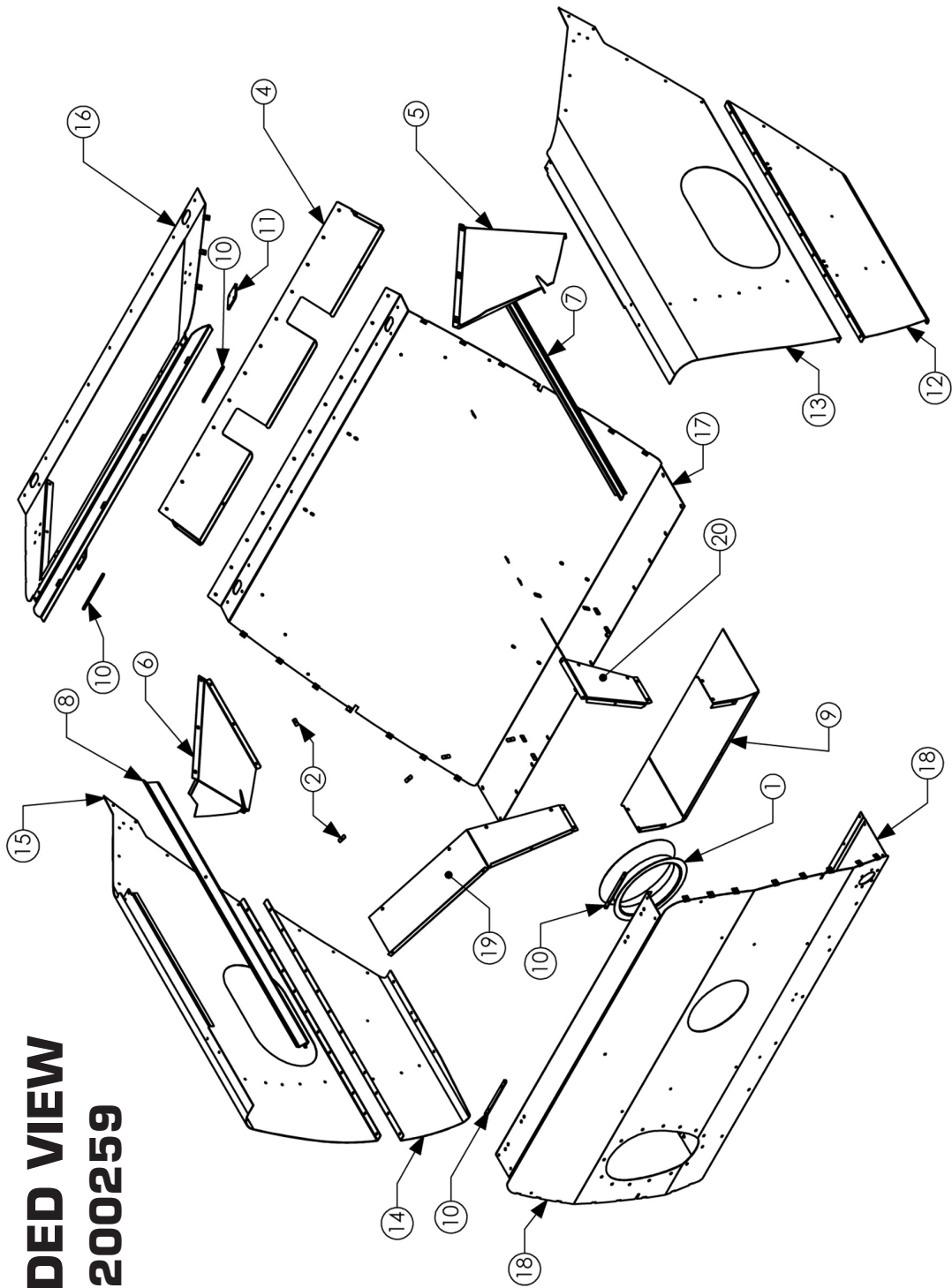

HOPPER ASSEMBLY

PARTS REQUIREMENTS

ITEM NO.	PART NUMBER	DESCRIPTION	QTY.
1	50012	SCROLL HOPPER SEPARATOR	1
2	50044	SS WELD NUT 3\8-16 NDZ-3324	16
3	50076	SS WELD NUT 5\16 NDZ-2724	8
4	2000071	HOPPER TAIL PLATE	1
5	2000074	LH DUMP GUSSET HOPPER	1
6	2000075	RH DUMP GUSSET HOPPER	1
7	2000076	LH TOP RIB HOPPER	1
8	2000078	RH UPPER RIB HOPPER	1
9	2000081	LOWER BASIN SEPARATOR HOPPER	1
10	2000241	BOLT PLATE HOPPER DOOR HINGES	4
11	2000242	BOLT PLATE DUMP DOOR CYLINDER	2
12	2000257	LH LOWER HOPPER SIDE	1
13	2000258	LH UPPER HOPPER SIDE	1
14	2000259	RH LOWER SIDE HOPPER	1
15	2000260	RH UPPER SIDE HOPPER	1
16	2000944	R4 HOPPER SEAL PLATE	1
17	2000945	R4 REAR HOPPER PAN	1
18	2000946	R4 FRONT HOPPER PAN	1
19	2000947	R4 RH SEPARATOR WRAP HOPPER	1
20	2000948	R4 LH SEPARATOR WRAP HOPPER	1

HOPPER TOP DOOR ASSEMBLY

EXPLODED VIEW PART #300006

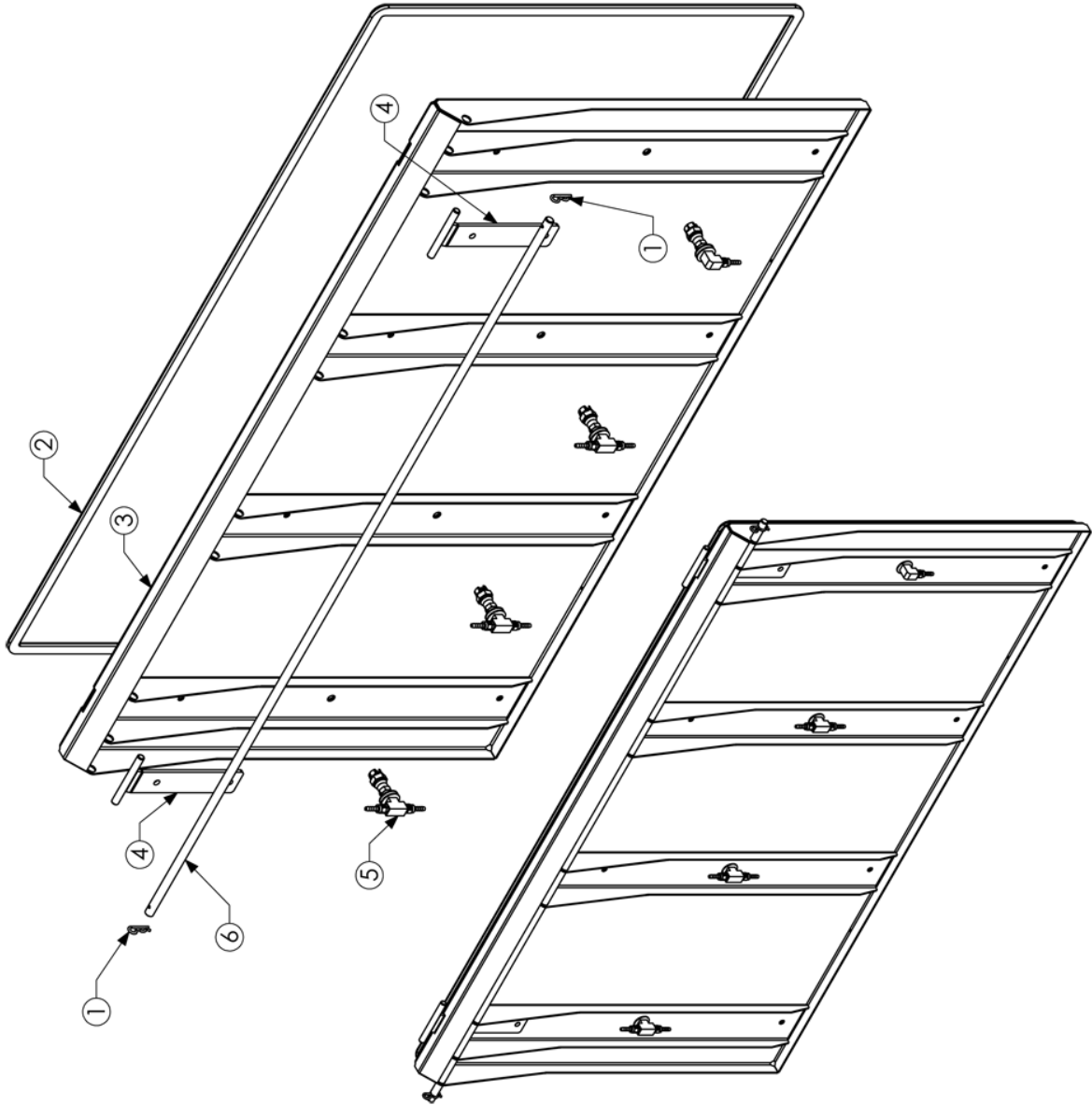

HOPPER TOP DOOR ASSEMBLY

PARTS REQUIREMENTS

ITEM NO.	QTY.	PART NUMBER	DESCRIPTION
1	2	50077	HAIR PIN COTTER 0.148
2	1	50407-202	TOP DOOR D SEAL 202"
3	1	200016	HOPPER TOP DOOR
4	2	200018	HINGE DUMP DOOR
5	1	300080	SCREEN SPRAYER SYSTEM ASSY
6	1	2000099	LIFTING ROD TOP DOOR

DUMP DOOR ASSEMBLY

EXPLODED VIEW PARTS #300214

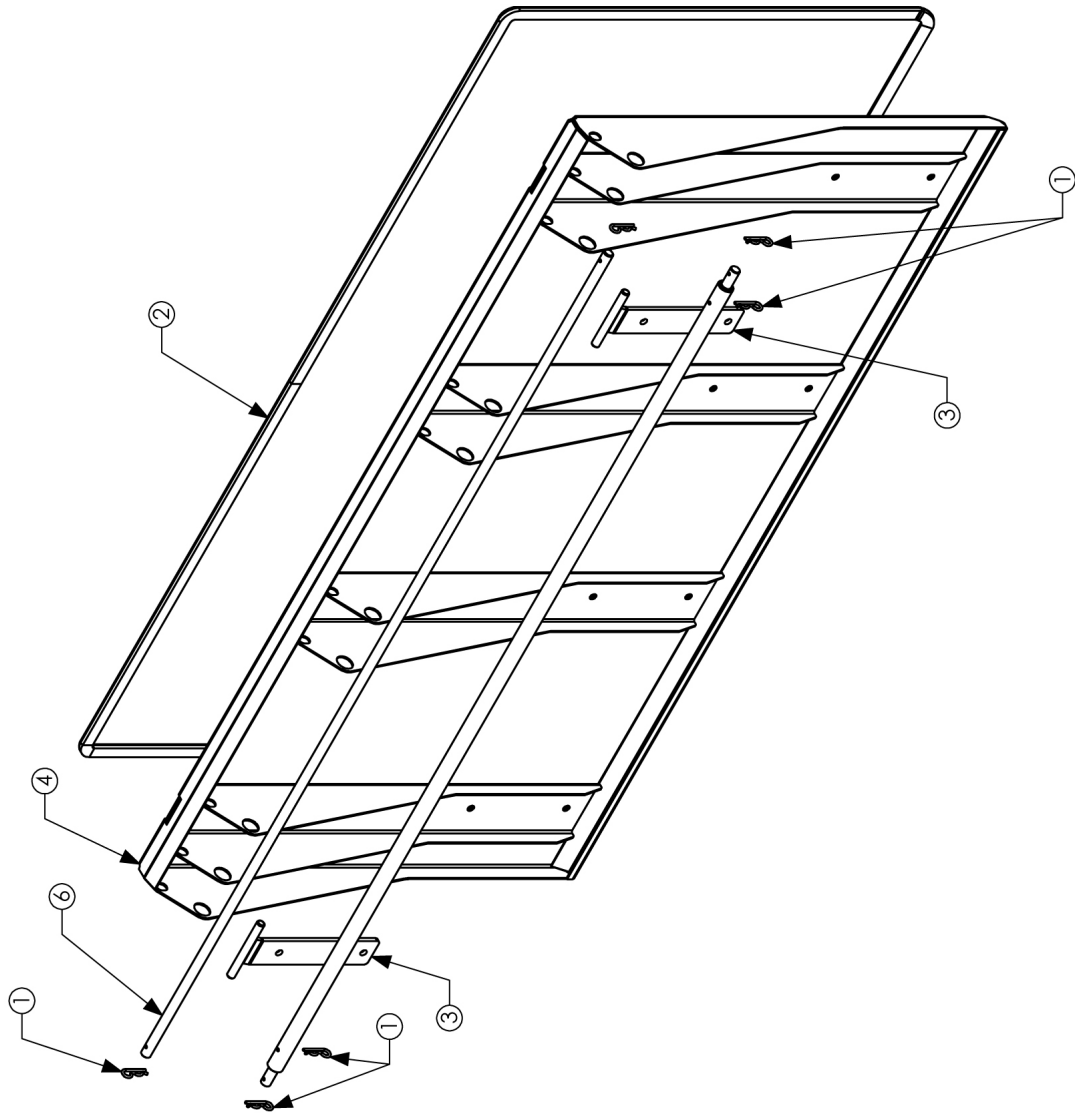

DUMP DOOR ASSEMBLY

PARTS REQUIREMENTS

ITEM NO.	PART NUMBER	DESCRIPTION	QTY.
1	50077	HAIR PIN COTTER 0.148	6
2	50407-192	DEAL SEAL DUMP DOOR 192"	1
3	200018	HINGE DUMP DOOR	2
4	200231	R4 DUMP DOOR WELDMENT	1
5	2000098	LIFT ROD DUMP DOOR	1
6	2000099	LIFTING ROD TOP DOOR	1

HOPPER INSPECTION DOOR ASSEMBLY

**EXPLODED VIEW
PART #300007**

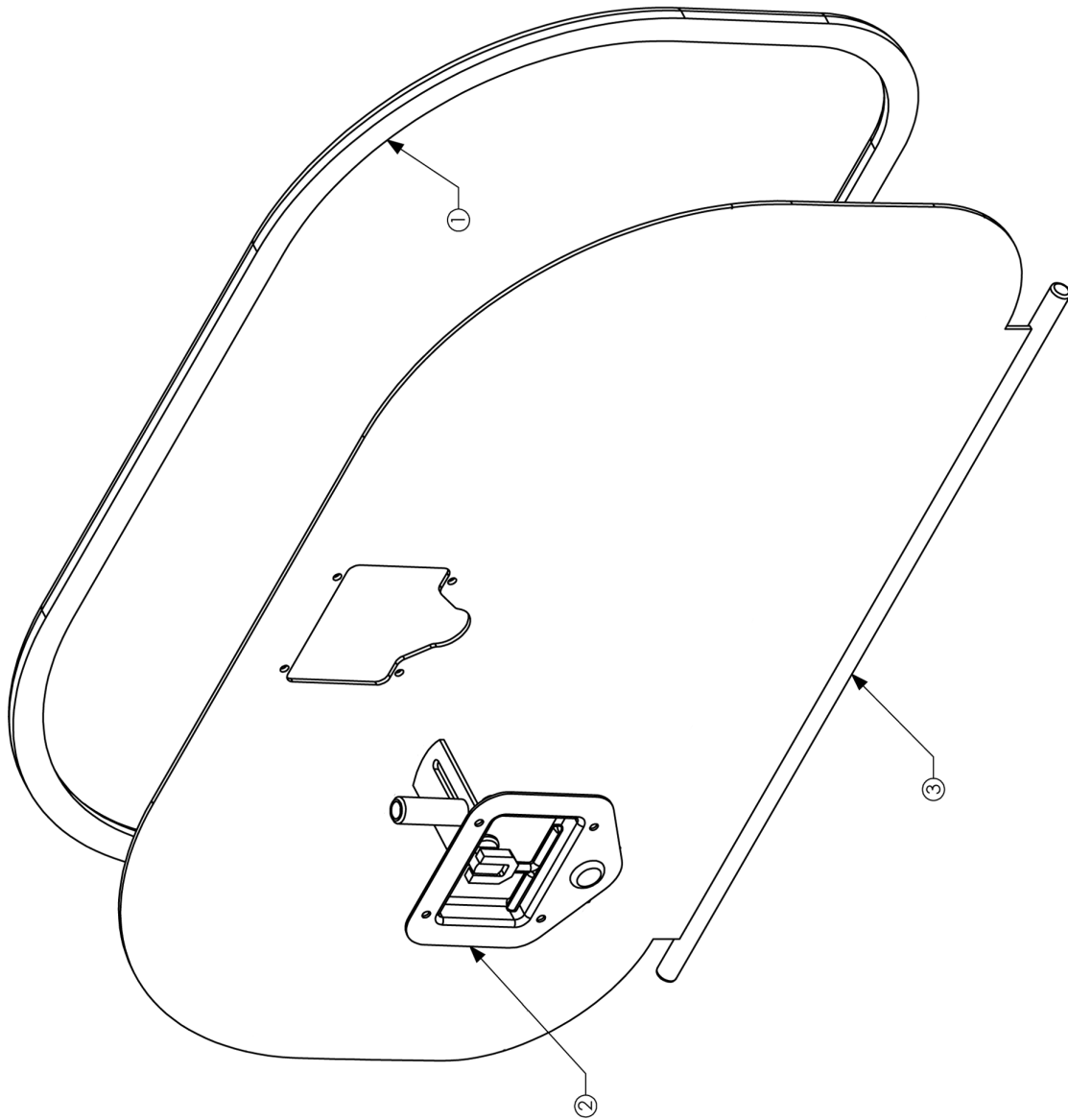

HOPPER INSPECTION DOOR ASSEMBLY

PARTS REQUIREMENTS

ITEM NO.	QTY.	PART NUMBER	DESCRIPTION
1	1	50407-068	INSPECTION DOOR D SEAL 68"
2	1	50625	SS SHROUD LATCH
3	1	200020	HOPPER INSPECTION DOOR
4	4	NOT SHOWN	BHCS 10-32 X 1/2 SS
5	4	NOT SHOWN	LOC-NUT 10-32 SS NYLOCK

HOPPER DRAIN ASSEMBLY

EXPLODED VIEW

PART #300218

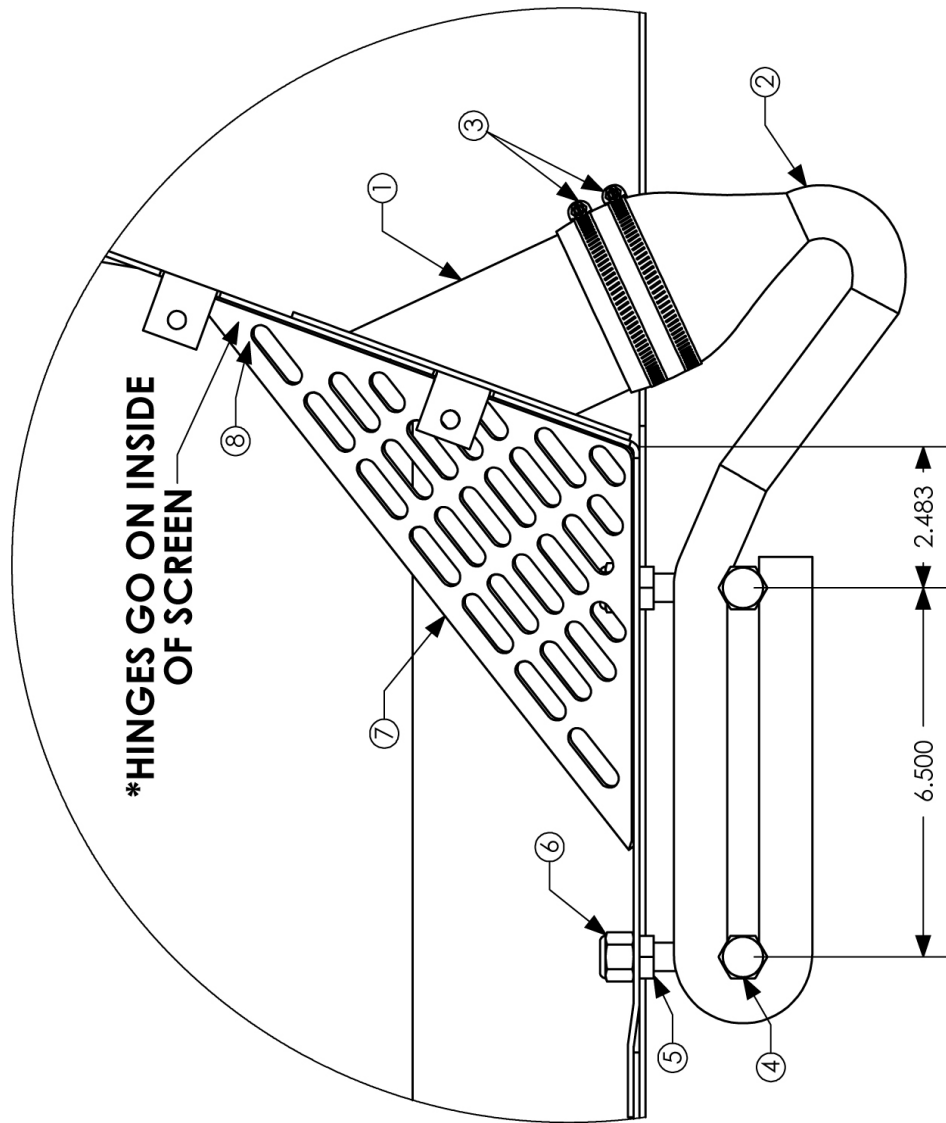

HOPPER DRAIN ASSEMBLY

PARTS REQUIREMENTS

ITEM NO.	QTY.	PART NUMBER	DESCRIPTION
1	1	200076	HOPPER DRAIN TUBE ASSY 3"
2	1	50985-030	HOSE, 3" DRAIN BLUE PVC LAYFLAT
3	2	HARHS2	#52 Hose Clamp
4	2	2000599	DRAIN HOSE HANGER BOLT
5	2	40081	HEX JAM NUT 1/2-13
6	2	40010	NUT LOC 1/2"-13
7	1	2000950	HOPPER DRAIN SCREEN R4
8	2	50385	SS PIANO HINGE 14 GA X 2 X 7"

8" HAND HOSE ASSEMBLY

EXPLODED VIEW

PART #300064

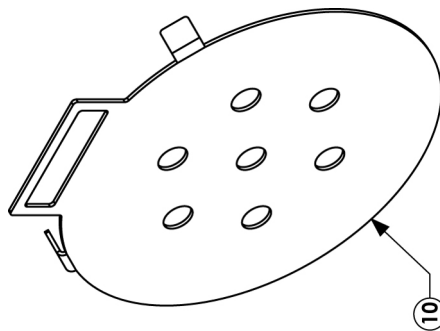
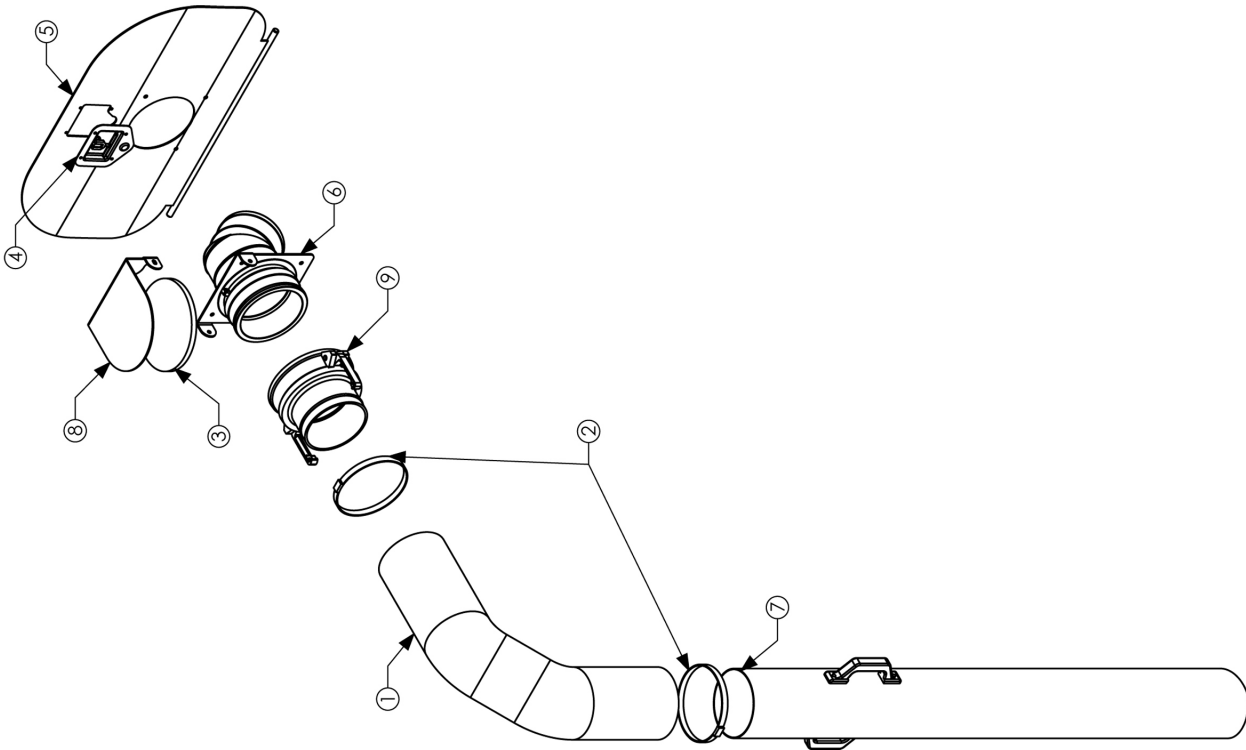

8" HAND HOSE ASSEMBLY

PARTS REQUIREMENTS

ITEM NO.	QTY.	PART NUMBER	DESCRIPTION
1	1	50347-144	6" BLACK FLEX HOSE
2	2	50348	HOSE CLAMP (5 TO 6-1/2")
3	1	50349	SEAL, 1/2" X 8" OD OPEN CELL
4	1	50625	SS SHROUD LATCH
5	1	200079	HOPPER INSPECTION DOOR
6	1	200137	HAND HOSE ATTACHMENT
7	1	300065	HAND HOSE NOZZLE ASSY
8	1	2000345	HAND HOSE DUST COVER PLATE
9	1	2000348	HOSE COUPLER PART C -AM-
10	1	2000349	HAND HOSE BLOCK-OFF PLATE

SHROUD ASSEMBLY

EXPLODED VIEW PART #300026

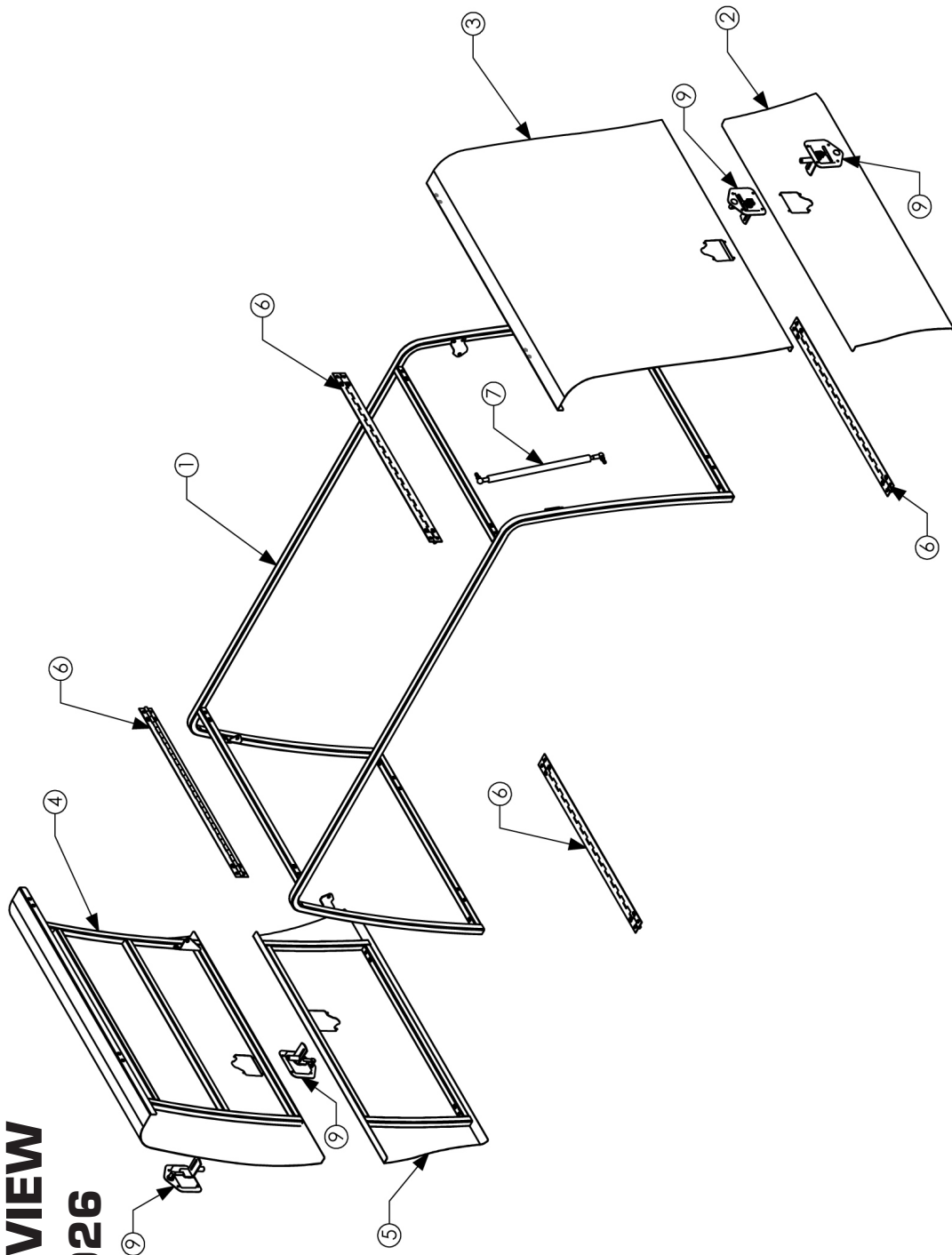

SHROUD ASSEMBLY

PARTS REQUIREMENTS

ITEM NO.	Default/QTY.	PART NUMBER	DESCRIPTION
1	1	200058	SHROUD FRAME ASSY
2	1	200060	LH LOWER SHROUD DOOR
3	1	200059	LH UPPER SHROUD DOOR
4	1	200061	RH UPPER SHROUD DOOR
5	1	200062	RH LOWER SHROUD DOOR
6	4	50257	SS PIANO HINGE 14 GA X 2 X 31-1 1/2"
7	4	50900	GAS SPRING 58#
8	4	50625	SS SHROUD LATCH

STAINLESS TOOLBOX DOOR ASSEMBLY

EXPLODED VIEW PART #300009

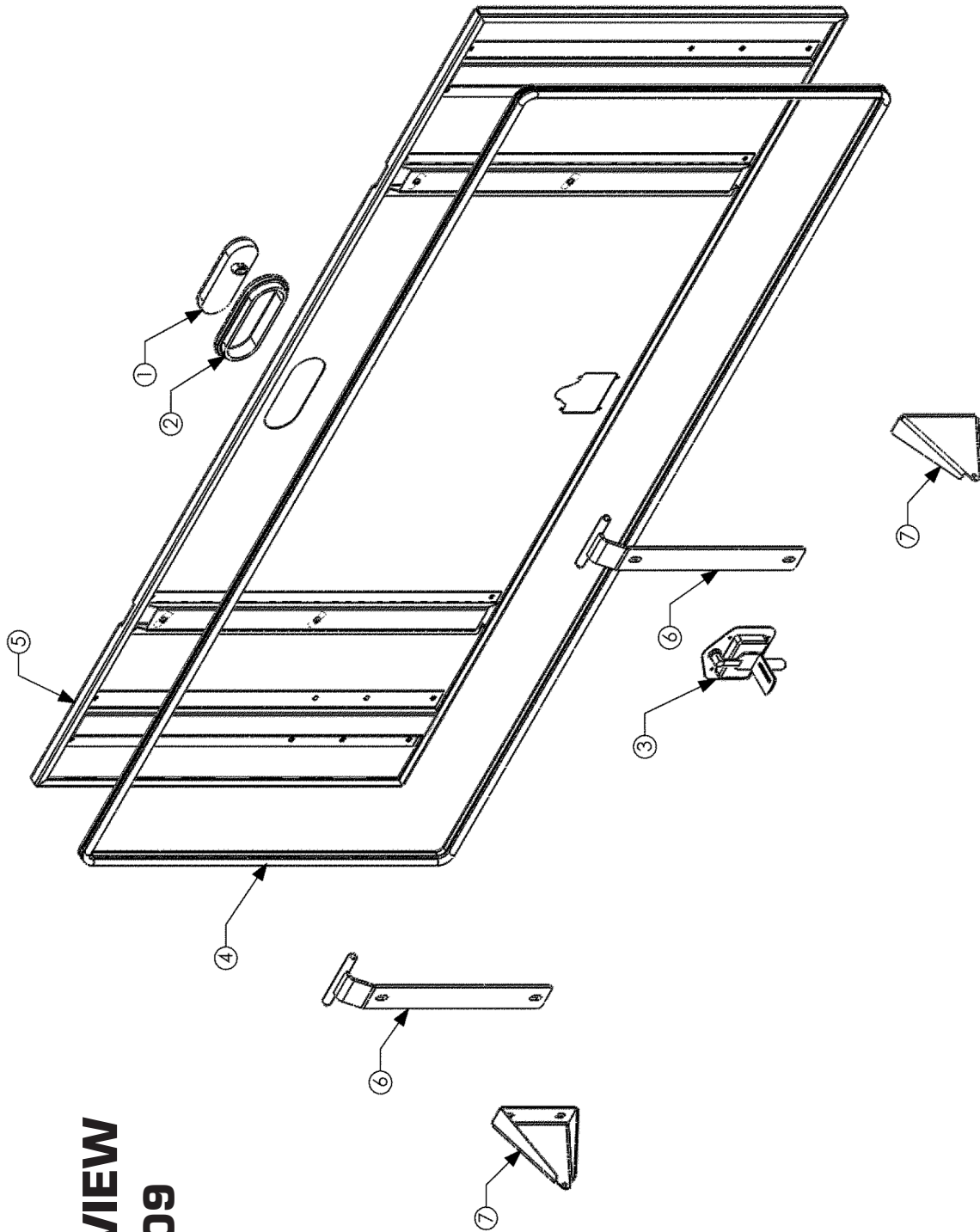

STAINLESS TOOLBOX DOOR ASSEMBLY

PARTS REQUIREMENTS

ITEM NO.	QTY.	PART NUMBER	DESCRIPTION
1	1	50139	RED OVAL LED TAIL LIGHT 6-1\2
2	1	50140	OVAL LIGHT GROMMET 6-1\2"
3	1	50625	SS SHROUD LATCH
4	1	50884-210	TRIM SEAL 1/16" SIDE BULB
5	1	200024	TOOLBOX DOOR WELDMENT
6	2	200025	TOOLBOX DOOR HINGE
7	2	2000240	MOUNT GAS SPRING TOOLBOX DOOR

TOOLBOX ASSEMBLY (WITH ALUMINUM DOOR)

**EXPLODED VIEW
PART #300067**

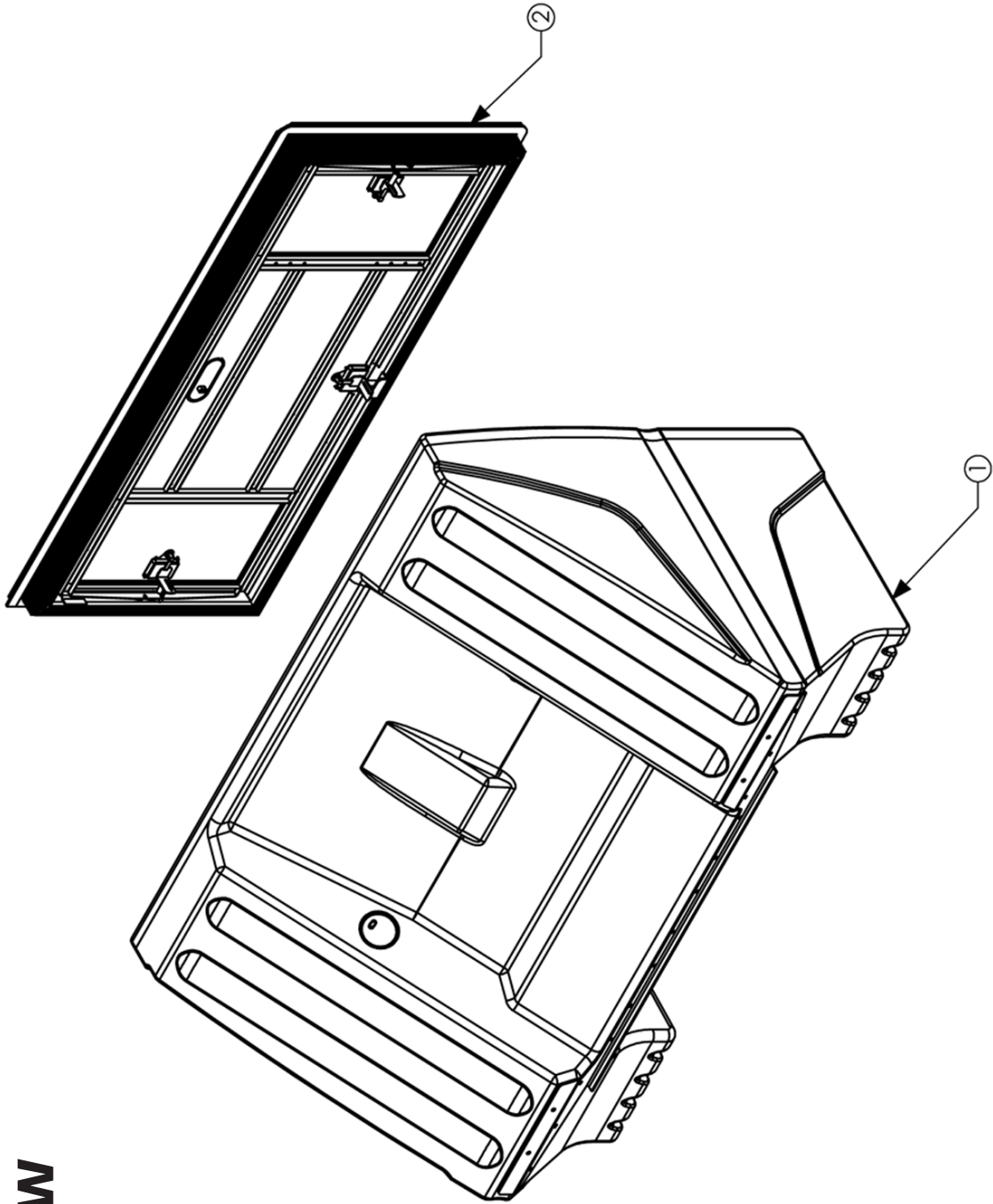

TOOLBOX ASSEMBLY (WITH ALUMINUM DOOR)

PARTS REQUIREMENTS

ITEM NO.	QTY.	PART NUMBER	DESCRIPTION
1	1	300008	TOOLBOX FINAL ASSY
2	1	300027	TOOLBOX DOOR ASSY (NEW)

ALUMINUM TOOLBOX DOOR ASSEMBLY

EXPLODED VIEW PART #300027

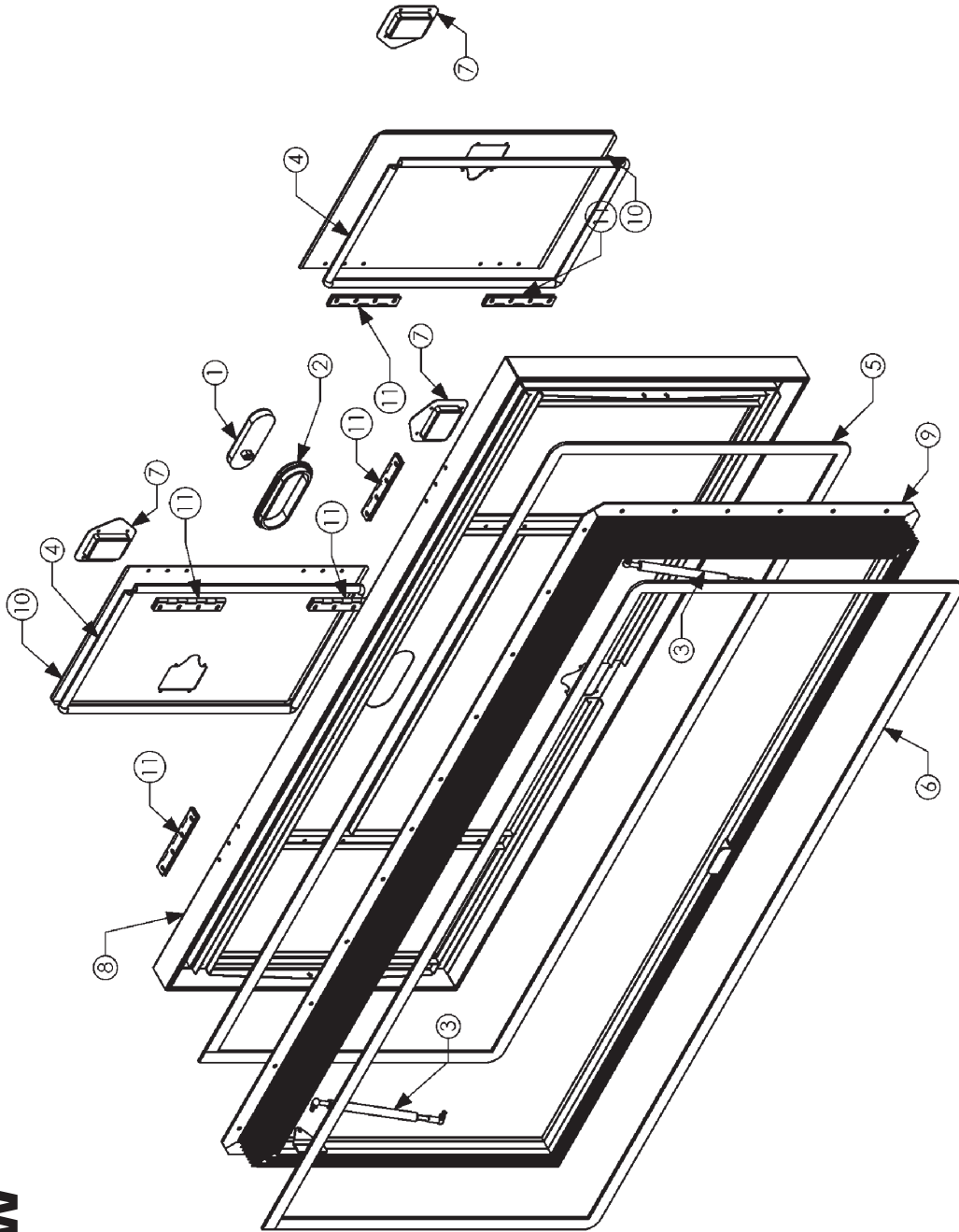

ALUMINUM TOOLBOX DOOR ASSEMBLY

PARTS REQUIREMENTS

ITEM NO.	Default/Qty.	PART NUMBER	DESCRIPTION
1	1	50139	RED OVAL LED TAIL LIGHT 6-1\2
2	1	50140	OVAL LIGHT GROMMET 6-1\2"
3	2	50296	GAS SPRING GSS6397 Uf 65 LB
4	2	50407-076	D-SEAL 3/4" [76"]
5	1	50462-210	1/4 X 1-1/4" STRIP [210"]
6	1	50462-216	1/4 X 1-1/4" STRIP [216" LONG]
7	3	50625	SS SHROUD LATCH
8	1	200082	REAR TOOLBOX DOOR (ALUMINUM)
9	1	200083	REAR DOOR FRAME TOOLBOX
10	2	2000274	ACCESS DOOR TOOLBOX (ALUMINUM)
11	6	50385	SS PIANO HINGE 14 GA X 2 X 7"

GUTTER BROOM ASSEMBLY (BOTH SIDES)

EXPLODED VIEW PART #300015

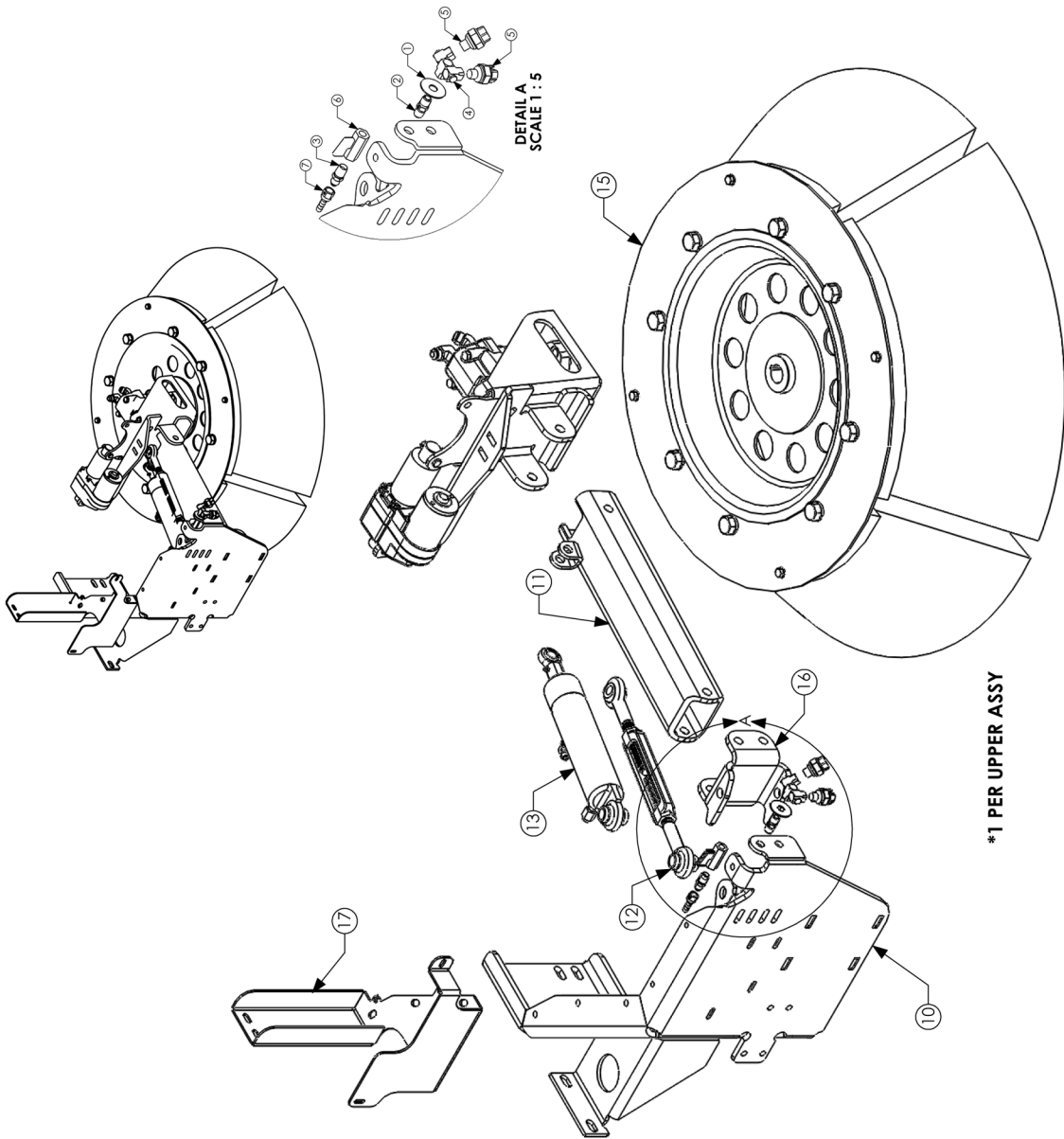

LEFT SIDE GUTTER BROOM ASSEMBLY

PARTS REQUIREMENTS

ITEM NO.	QTY.	PART NUMBER	DESCRIPTION
1	1	40085	WASHER 1/2" STAINLESS STEEL
2	1	50094	1/4 BRASS HEX NIPPLE
3	1	50324	CONNECTOR 1/4" FLARE X 1/4" NPT BRASS
4	1	50433	DUAL SWIVEL WATER SPRAY
5	2	50542	BEX SPRAY NOZZLE
6	1	50634	1/4" BALL VALVE
7	1	50638	HOSE END SWIVEL 1/4 JIC PUSH LOCK
8	1	50660	RUBBER HOUSING FOR GB LIGHT (NOT SHOWN)
9	1	50932	4" LED WORK LIGHT (NOT SHOWN)
10	1	200030	LH GUTTER BROOM BRACKET
11	1	200031	LH GUTTER BROOM ARM
12	1	200032	G/B TURNBUCKLE WELDMENT
13	1	300036	GUTTER BROOM CYLINDER KIT
14	1	300045	LH G/B MOTOR MOUNT ASSY
15	1	300046	G/B SPINNER ASSY
16	1	2000131	BROOM ARM CLEVIS
17	1	2000234	FUEL FILTER TRANS FILTER MOUNT GMC

GUTTER BROOM MOTOR MOUNT ASSEMBLY (BOTH SIDES)

EXPLODED VIEW
PART #300045

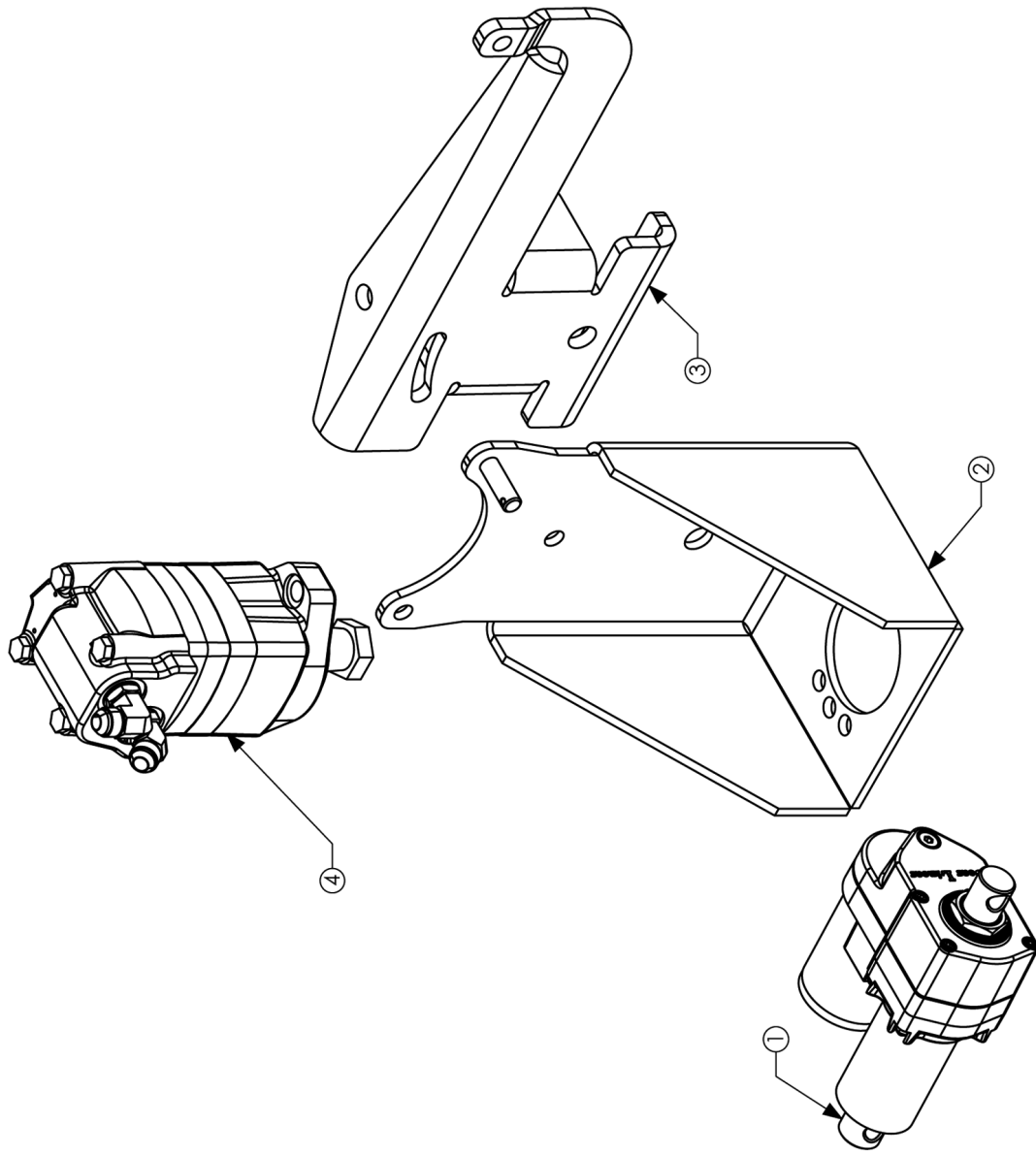

LEFT SIDE GUTTER BROOM MOTOR MOUNT ASSEMBLY

PARTS REQUIREMENTS

ITEM NO.	PART NUMBER	DESCRIPTION	QTY.
1	50086	ACTUATOR 2" X 12 LB	1
2	200034	LH MOTOR MOUNT G/BROOM	1
3	2000132	LH PIVOT PLATE MOTOR MOUNT	1
4	300041	GUTTER BROOM MOTOR ASSY	1

GUTTER BROOM MOTOR ASSEMBLY

**EXPLODED VIEW
PART #300041**

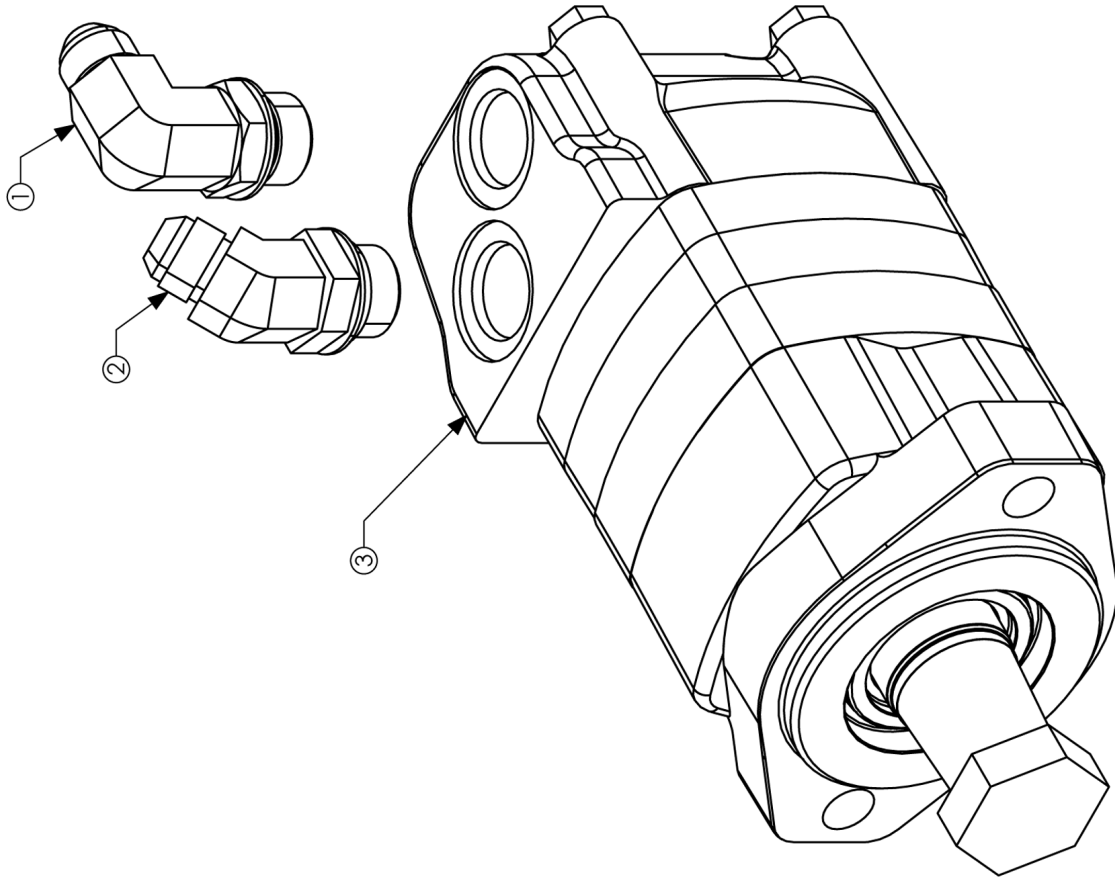

GUTTER BROOM MOTOR ASSEMBLY

PARTS REQUIREMENTS

ITEM NO.	QTY.	PART NUMBER	DESCRIPTION
1	1	50430	ELBOW 90° 1/2 MJIC X 5/8 SAE
2	1	50431	ELBOW 45° 1/2 JIC X 5/8 SAE
3	1	50711	MOTOR BROOM 104-1008-006 4.9 CU IN

GUTTER BROOM SPINNER ASSEMBLY

EXPLODED VIEW PART #300091

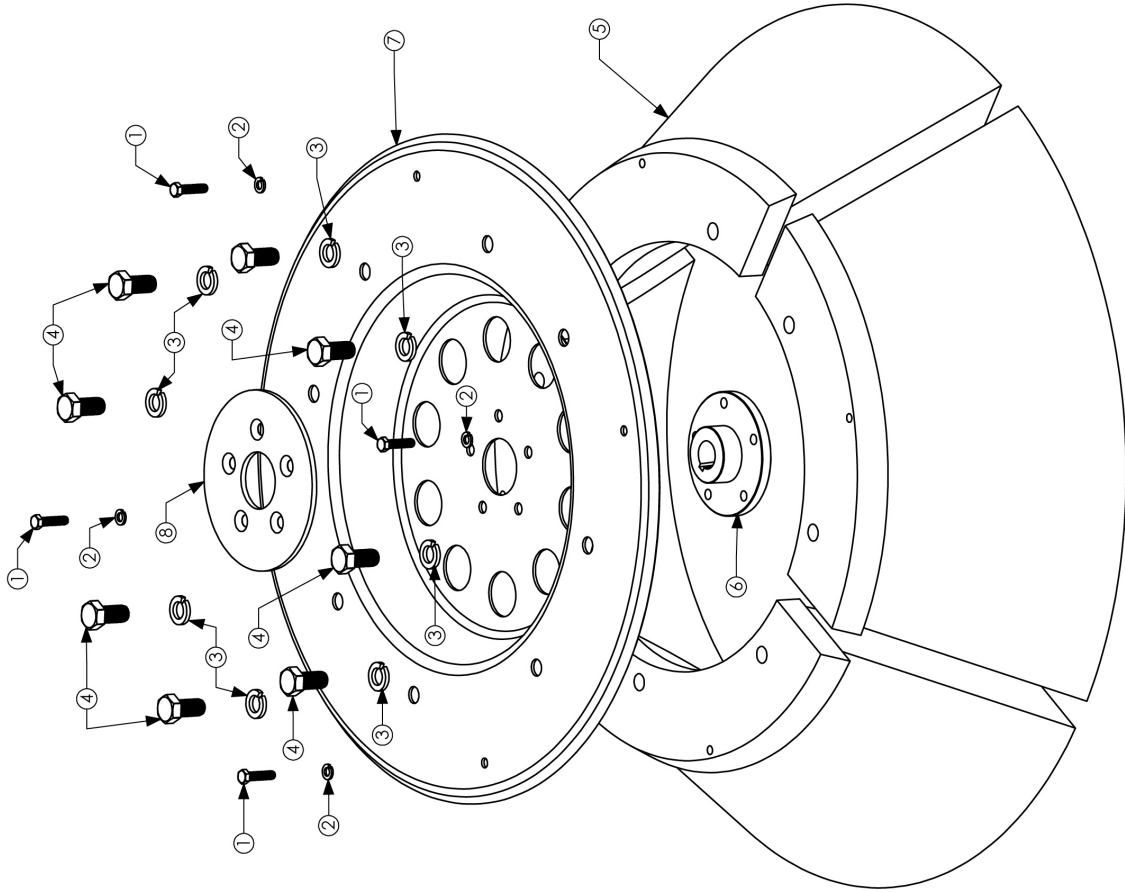

GUTTER BROOM SPINNER ASSEMBLY

PARTS REQUIREMENTS

ITEM NO.	PART NUMBER	DESCRIPTION	QTY.
1	40002	SCREW HHSC 3/8-16 X 1-1/2 GR5	4
2	40027	WASHER SPRING LOCK 3/8"	4
3	40107	3/4" SPRING LOCK WASHER	8
4	40110	SCREW HHCS 3/4-10 X 1-1/2" GR 5	8
5	50161	GUTTER BROOM 4 SEGMENT 39"	1
6	51117	BROOM MOTOR HUB	1
7	51118	BROOM SPINNER DISC (NEW)	1
8	2000829	BROOM SPINNER SUPPORT DISC (NEW)	1

GUTTER BROOM CYLINDER PREP ASSEMBLY

EXPLODED VIEW PART #300047

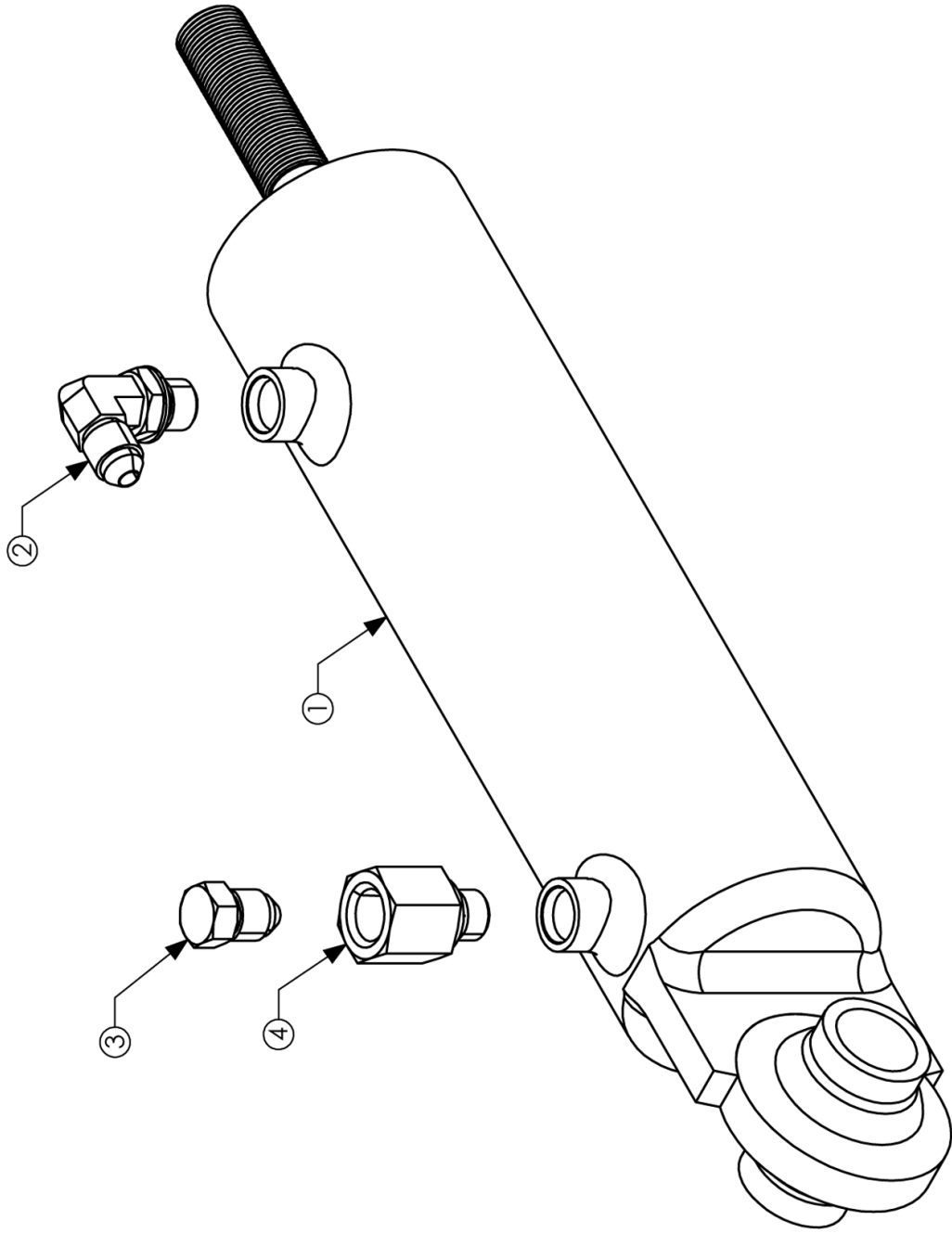

GUTTER BROOM CYLINDER PREP ASSEMBLY

PARTS REQUIREMENTS

ITEM NO.	QTY.	PART NUMBER	DESCRIPTION
1	1	50067	HYD CYLINDER 2 X 5
2	1	50230	ELBOW 90° 1/4 JIC X 1/4 SAE
3	1	50671	1/4" NPT VENTED PLUG
4	1	50672	ADAPTER 1/4" SAE X 1/4" FNPT

GUTTER BROOM CYLINDER ASSEMBLY

EXPLODED VIEW

PART #300048

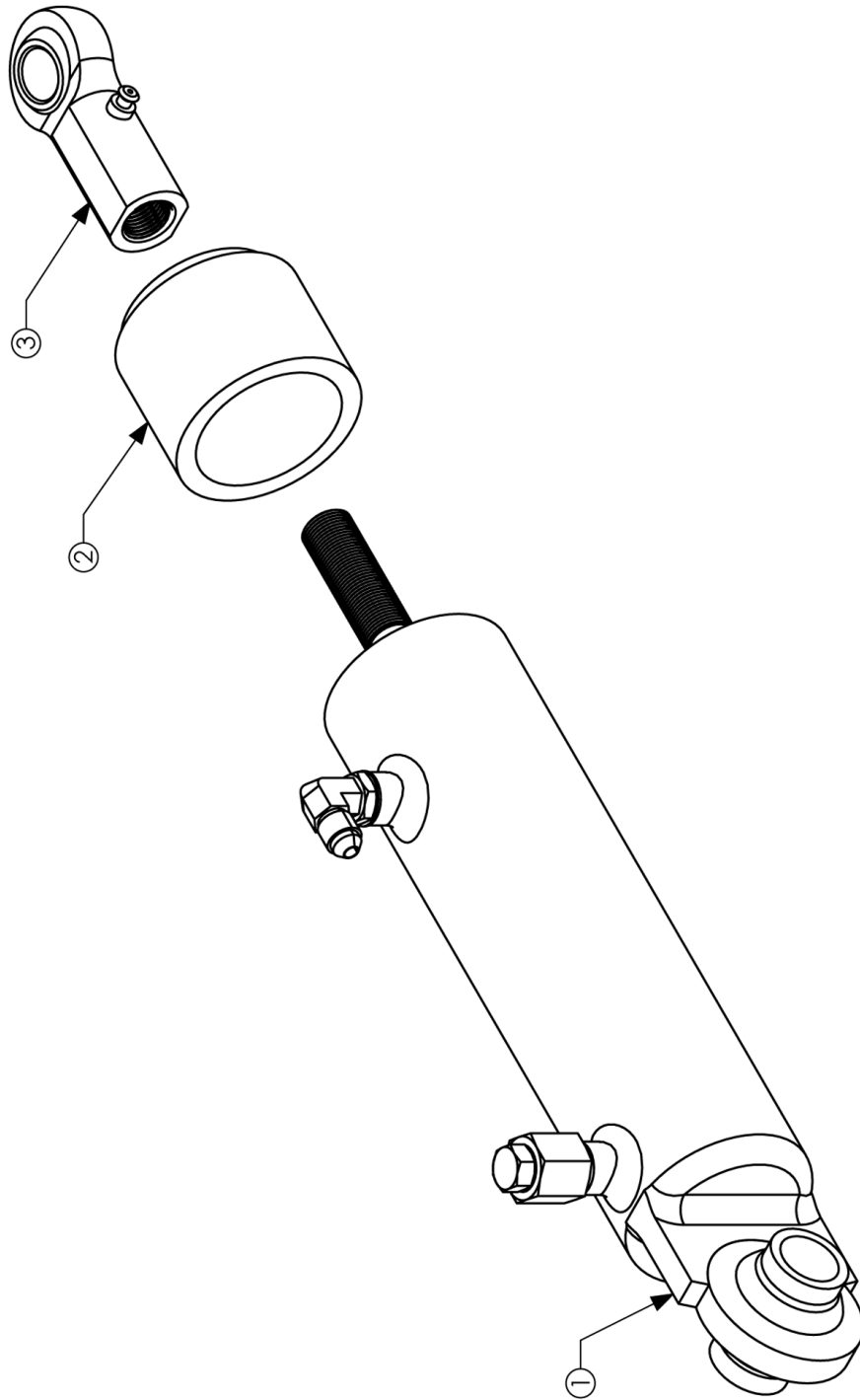

GUTTER BROOM CYLINDER ASSEMBLY

PARTS REQUIREMENTS

ITEM NO.	PART NUMBER	QTY.	DESCRIPTION
1	300047	1	G/B CYLINDER PREP ASSY
2	200057	1	BROOM CYLINDER STOP
3	50073	1	5/8" ROD END SWIVEL

COMPLETE HEAD ASSEMBLY

EXPLODED VIEW PART #300213

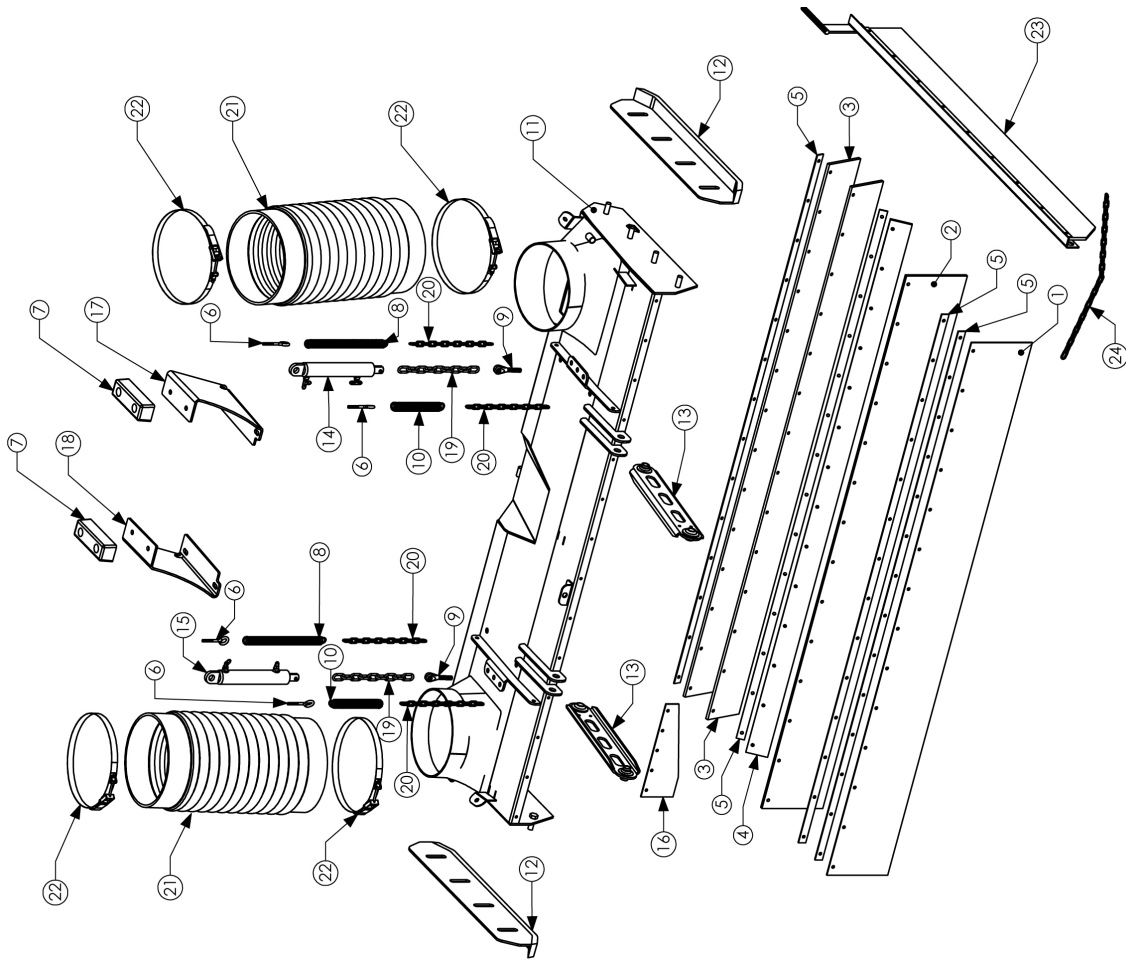

COMPLETE HEAD ASSEMBLY

PARTS REQUIREMENTS

ITEM NO.	PART NUMBER	DESCRIPTION	QTY.
1	21706-081	FRONT FLAP HEAD	1
2	21707-081	MIDDLE FLAP HEAD	1
3	21709-081	REAR FLAP HEAD	2
4	23151-081	BLAST ORIFICE FLAP	1
5	5202023	BACKING STRIP HEAD	4
6	40170	3/8 x 4 EYE BOLT	4
7	50035	RUBBER BUMPER T-42	2
8	50410	EXTENSION SPRING 1 x 12	2
9	50685	CLEVIS BOLT 1/2-20 x 7/16 ID x 2-1/2	2
10	51320	EXTENSION SPRING 1 X 8-1/4	2
11	600013	HEAD CHANNEL	1
12	600049	SKID PLATE HEAD	2
13	600050	DRAG ARM 18-1/2in	2
14	300037	LH HEAD CYLINDER KIT	1
15	300038	RH HEAD CYLINDER KIT	1
16	6000272	HEAD INTAKE EXTENSION	1
17	2000970	LH HEAD STOP EXTENSION R4	1
18	2000971	LH HEAD STOP EXTENSION R4	1
19	50200-012	1/4 GRADE 30 CHAIN	2
20	50202-013	3/16 GRADE 30 CHAIN	4
21	SPX21033	12 IN INTAKE TUBE	2
22	50702	CLAMP 12.25" TO 12.90" DIA	4
23	300216	DEFLECTOR FLAP ASSEMBLY R4	1
24	50202-024	3/16 GRADE 30 CHAIN	1

DEFLECTOR FLAP ASSEMBLY

EXPLODED VIEW

PART #300216

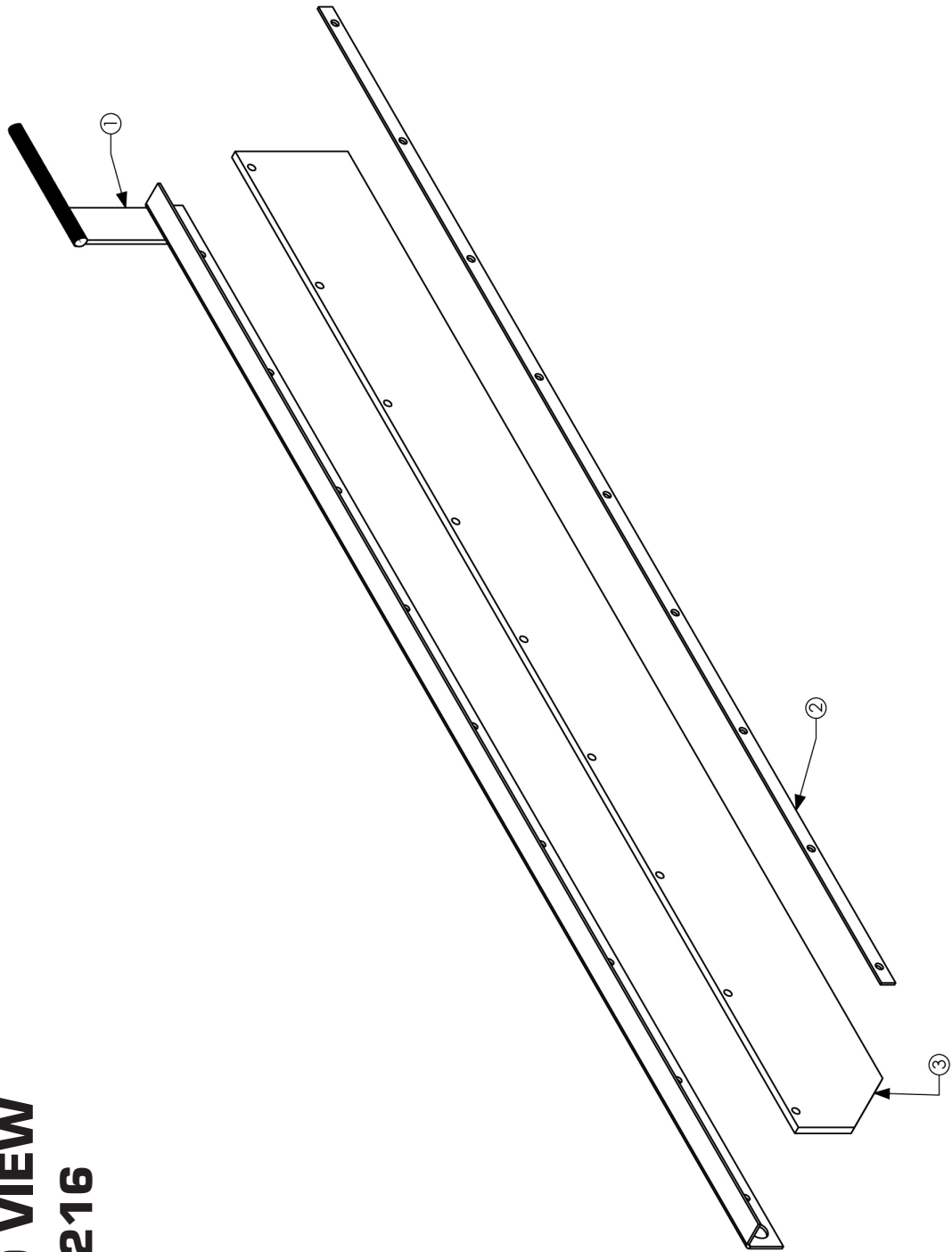

DEFLECTOR FLAP ASSEMBLY

PARTS REQUIREMENTS

ITEM NO.	PART NUMBER	DESCRIPTION	QTY.
1	200238	R4 DEFLECTOR FLAP ASSY	1
2	2000973	DEFLECTOR FLAP BACKING STRIP R4	1
3	2000974	R4 DEFLECTOR FLAP	1

HEAD DUST SUPPRESSION SYSTEM

EXPLODED VIEW PART #300252

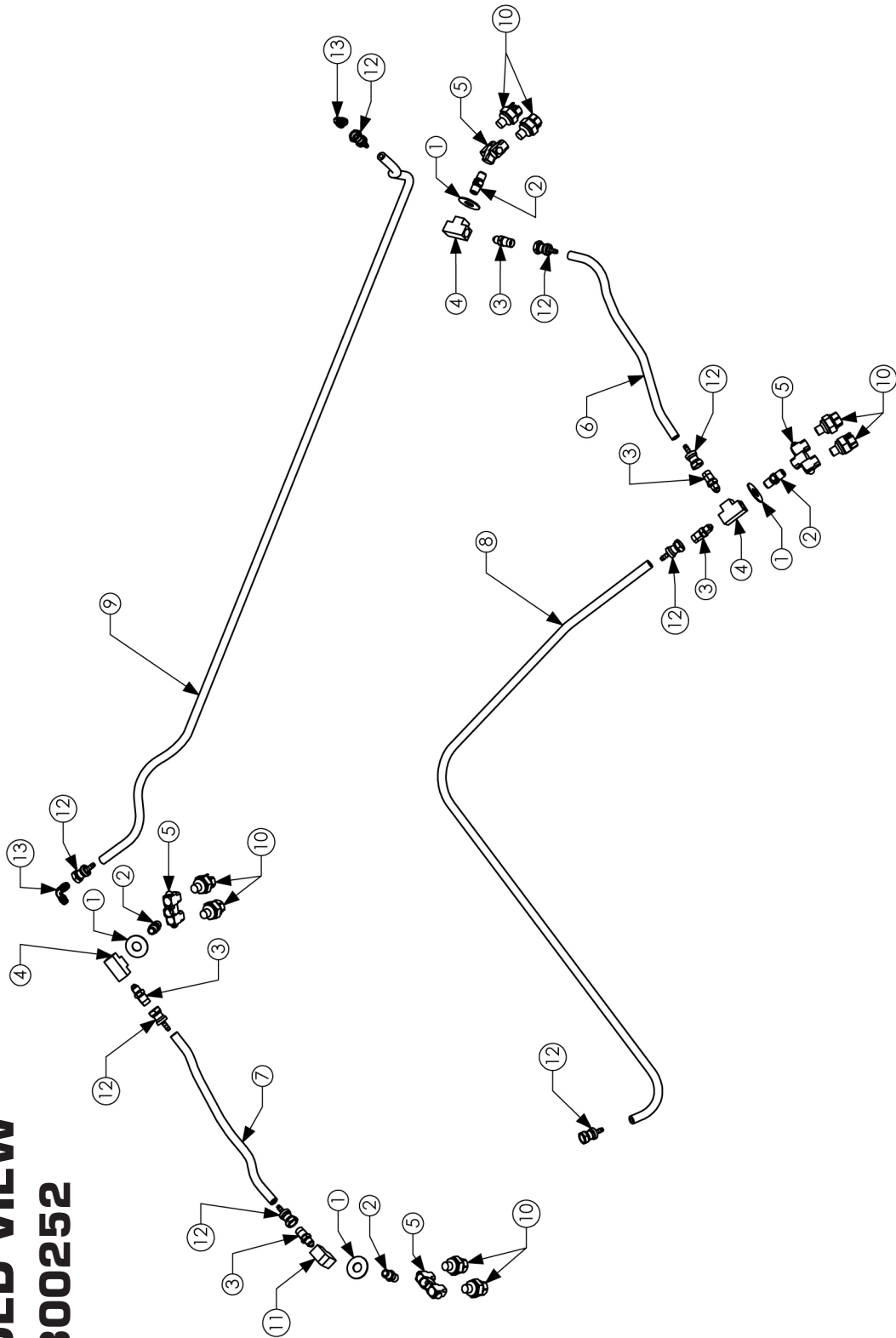

HEAD DUST SUPPRESSION SYSTEM

PARTS REQUIREMENTS

ITEM NO.	QTY.	PART NUMBER	DESCRIPTION
1	4	40007	WASHER FLAT 1/2"
2	4	50094	1\4 BRASS HEX NIPPLE
3	5	50324	CONNECTOR 1/4" FLARE X 1/4" NPT BRASS
4	3	50325	TEE 1/4" BRASS UNION
5	4	50433	DUAL SWIVEL WATER SPRAY
6	1	50454-015.	1/4" HOSE X 15"
7	1	50454-015	1/4" HOSE X 15"
8	1	50454-050	1/4" HOSE X 50"
9	1	50454-078	1/4" HOSE X 78"
10	8	50542	BEX SPRAY NOZZLE
11	1	50635	ELBOW 90° 1/4" BRASS UNION
12	8	50772	HOSE END 1/4" SWIVEL 45° FLARE X 1/4" HOSE
13	2	50818	ELBOW 90°, 1/4" 45° FLARE X 1/4" NPT

LEFT SIDE HEAD CYLINDER KIT

EXPLODED VIEW PART #300037

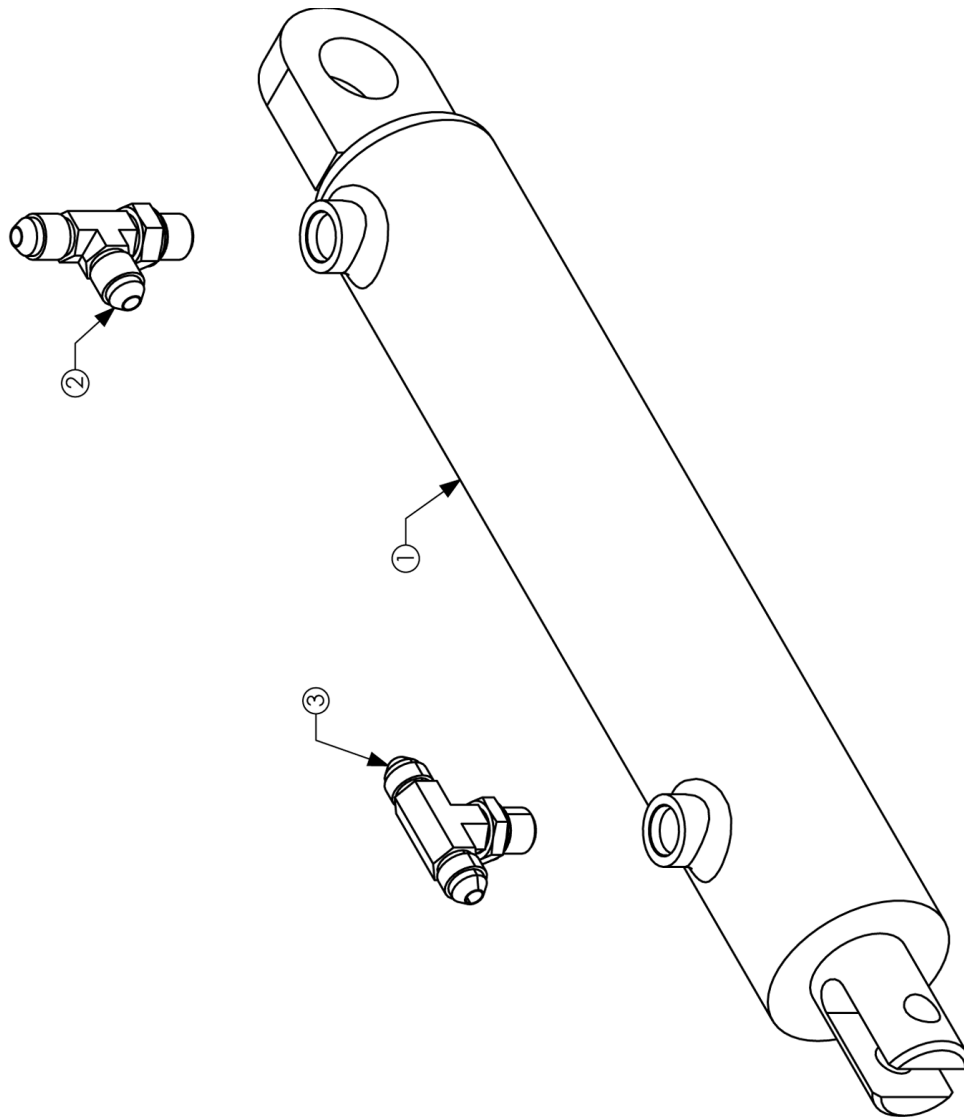

LEFT SIDE HEAD CYLINDER KIT

PARTS REQUIREMENTS

ITEM NO.	PART NUMBER	DESCRIPTION	QTY.
1	50030	HEAD CYL 1-1\2 X 6-1\2	1
2	50558	TEE 1/4 MJIC X 7/16-20 SAE X 1/4 MJIC	1
3	50760	TEE 1/4 MJIC X 1/4 MJIC X 7/16-20 SAE	1

RIGHT SIDE HEAD CYLINDER KIT

EXPLODED VIEW

PART #300038

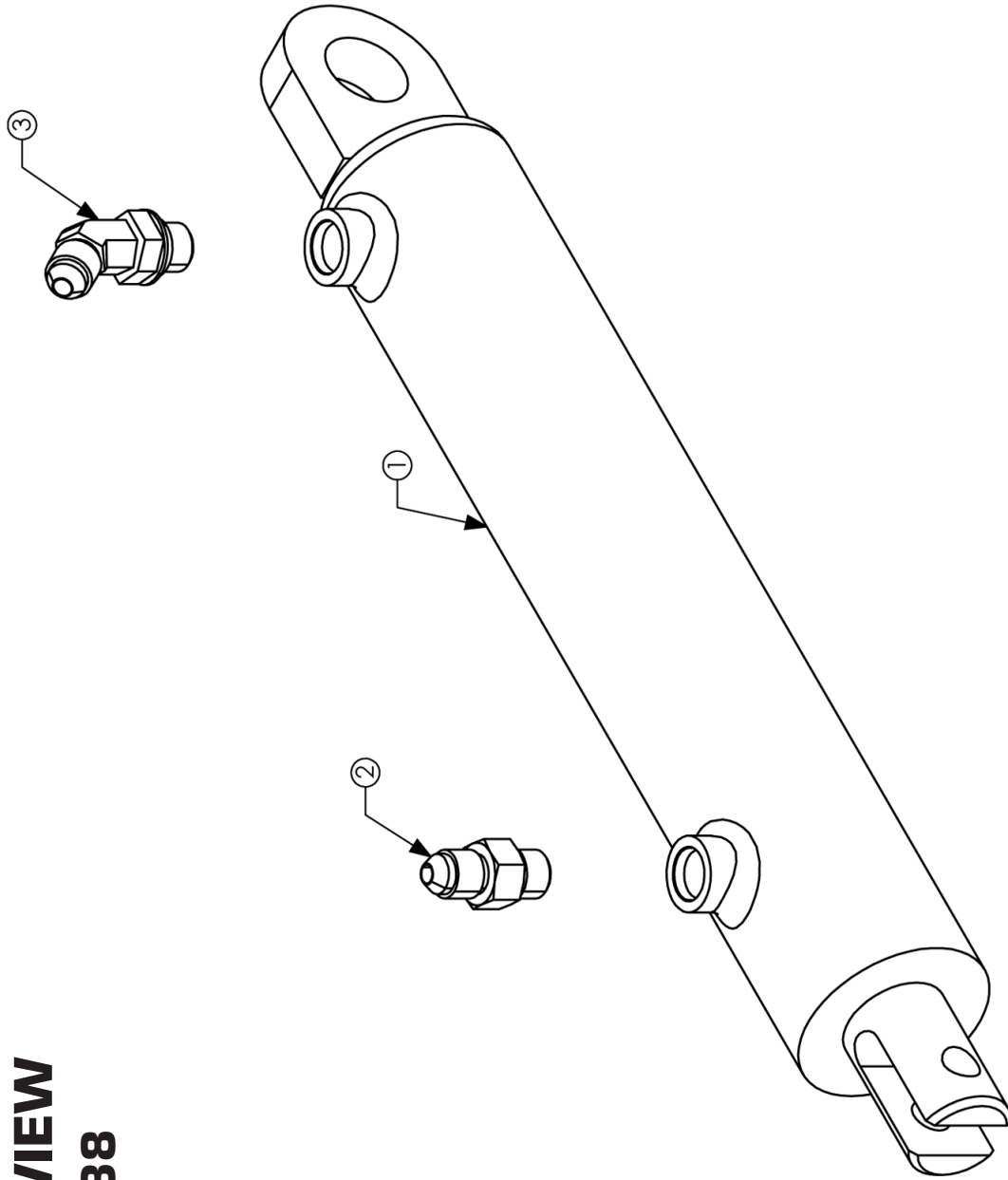

RIGHT SIDE HEAD CYLINDER KIT

PARTS REQUIREMENTS

ITEM NO.	QTY.	PART NUMBER	DESCRIPTION
1	1	50030	HEAD CYL 1-1/2 X 6-1/2
2	1	50228	CONNECTOR, 1/4 MJIC X 1/4 SAE
3	1	50229	ELBOW 45° 1/4 JIC X 1/4 SAE

SPRAY BAR ASSEMBLY

EXPLODED VIEW

PART #300050

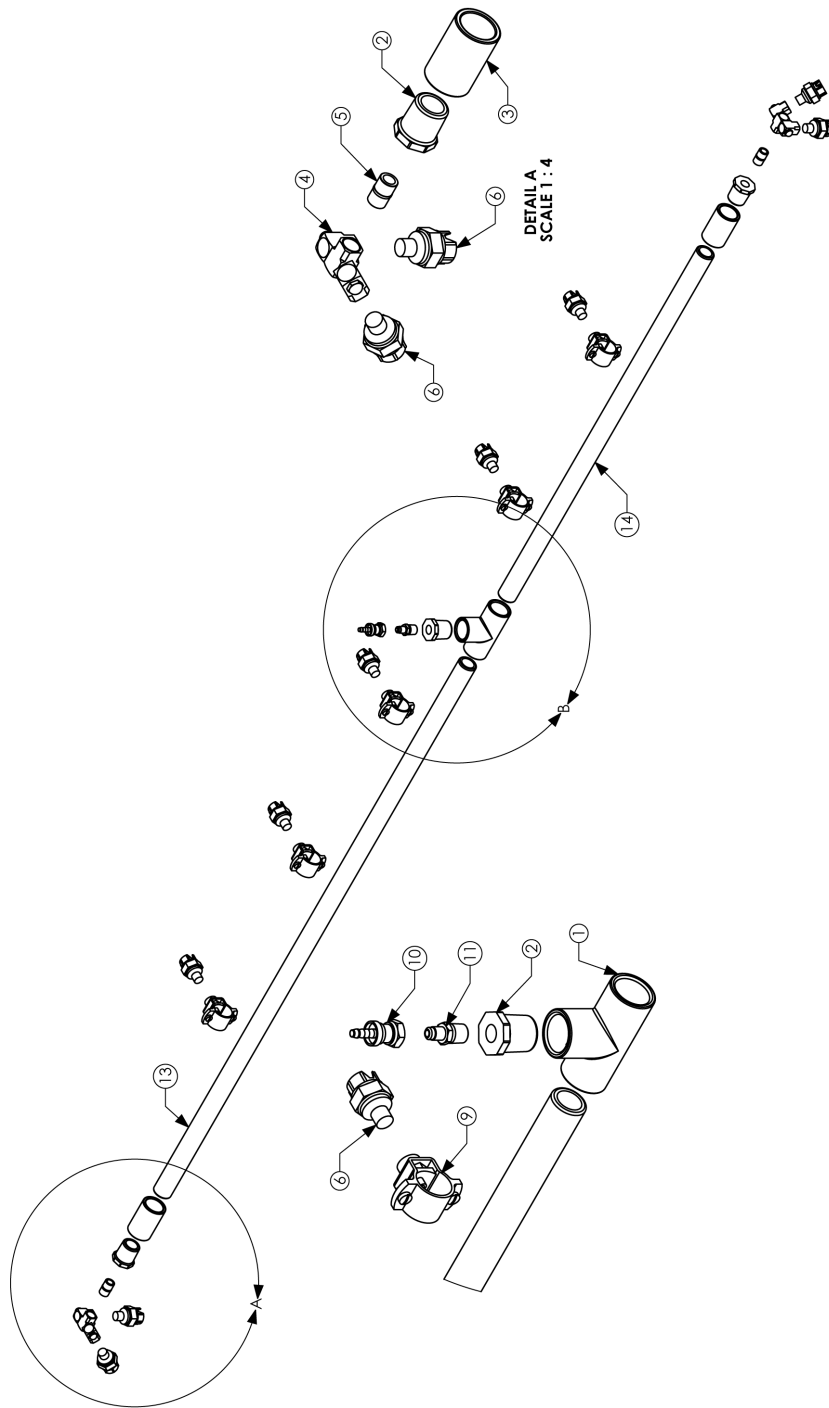

SPRAY BAR ASSEMBLY

PARTS REQUIREMENTS

ITEM NO.	QTY.	PART NUMBER	DESCRIPTION
1	1	50326	3/4 PVC TEE
2	3	50343	BUSHING 3/4 SLIP X 1/4 NPT PVC
3	2	50393	3/4 PVC COUPLING
4	2	50433	DUAL SWIVEL WATER SPRAY
5	2	50450	1/4" BRASS NIPPLE
6	9	50542	BEX SPRAY NOZZLE
7	1	50634	1/4" BALL VALVE (NOT SHOWN)
8	2	50638	HOSE END SWIVEL 1/4 JIC PUSH LOCK (NOT SHOWN)
9	5	50713	3/4 x 1/4 FEMALE SPLIT EYELET BRASS
10	1	50772	HOSE END 1/4" SWIVEL 45° FLARE X 1/4" HOSE
11	1	50773	CONNECTOR 1/4 MNPT X 1/4 SAE 45° FLARE
12	1	300013	12V WATER PUMP ASSY (NOT SHOWN)
13	1	2000455	LH SPRAY BAR TUBE (41.5")
14	1	2000456	RH SPRAY BAR TUBE (27")

DUAL STEERING ASSEMBLY

EXPLODED VIEW PART #300244

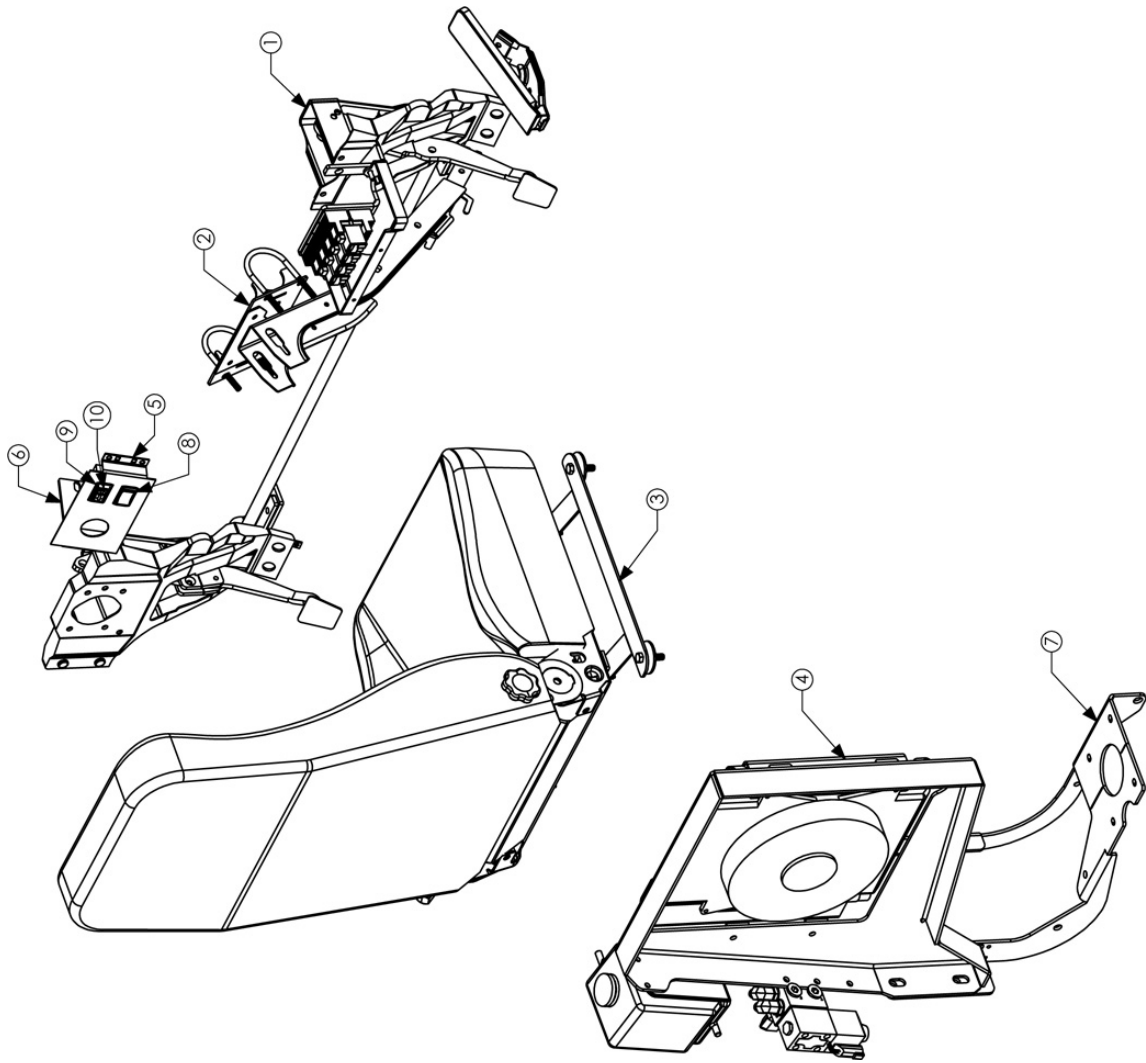

DUAL STEERING ASSEMBLY

PARTS REQUIREMENTS

ITEM NO.	Default /QTY.	PART NUMBER	DESCRIPTION
1	1	300280	CROSS SHAFT BRAKE PEDAL ASSY
2	1	300281	STEERING COLUMN ASSY PASSENGER SIDE
3	1	300279	SEAT ASSY
4	1	300278	AC CONDENSOR POWER STEERING ASSY
5	5	2000545	DUAL STEERING IGNITION MOUNT PLATE
6	1	2000544	DUAL STEER IGNITION SWITCH BRACKET
7	1	200278	AIR CLEANER MOUNT ISUZU 2009
8	1	51181	SWITCH, LH2-HOLE PLUG W/ SERRATED WINGS
9	1	51175	SWITCH, ROCKER SPST (O)-F
10	1	51560	SWITCH ACTUATOR DUAL STEERING
11	1	51335	DUAL STEERING KIT ISUZU 2009
12	1	51336	COVER DUAL STEERING KIT

CROSS SHAFT BRAKE PEDAL ASSEMBLY

EXPLODED VIEW

PART #300280

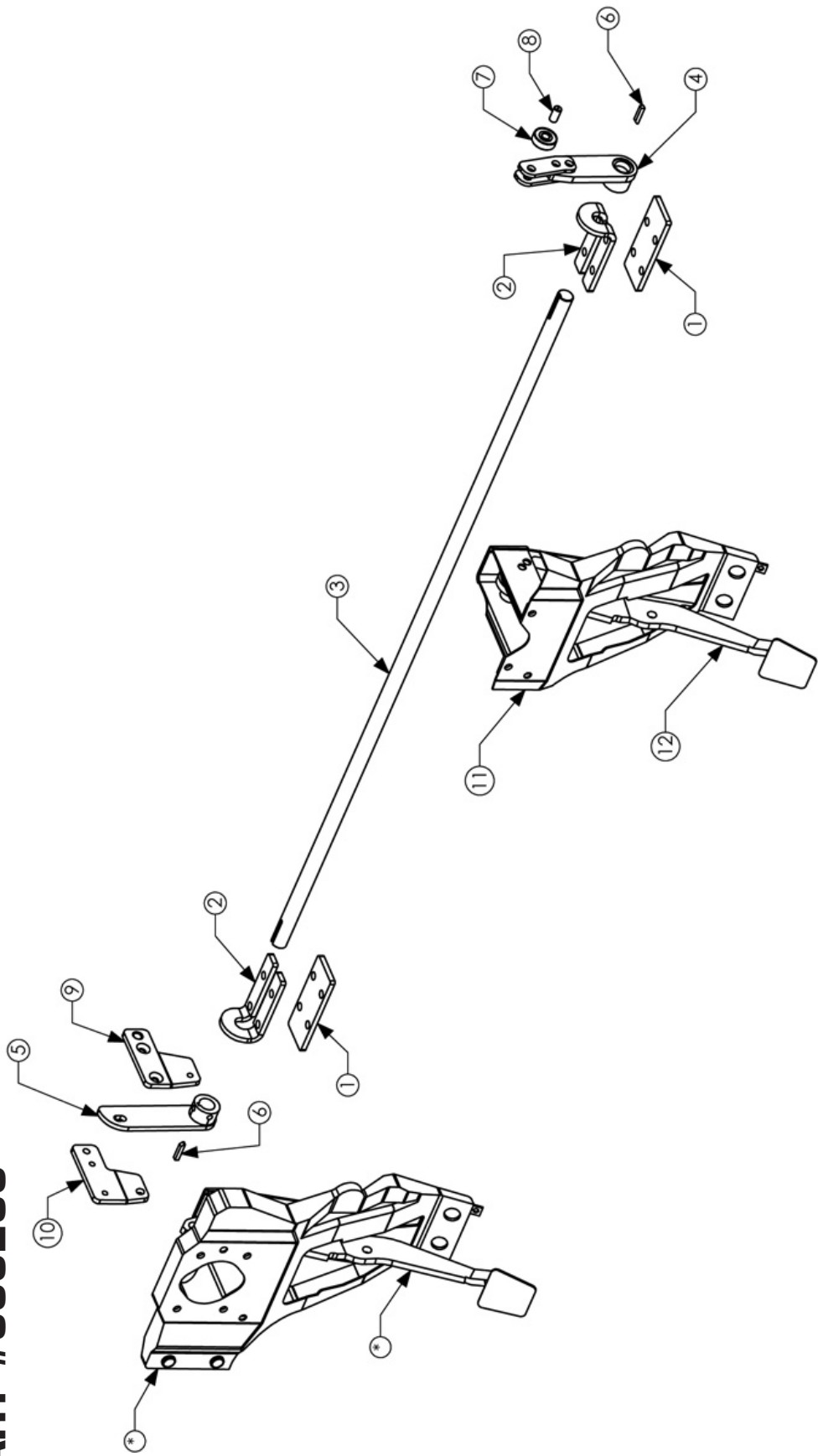

CROSS SHAFT BRAKE PEDAL ASSEMBLY

PARTS REQUIREMENTS

ITEM NO.	QTY.	PART NUMBER	DESCRIPTION
1	2	2000534	CROSSOVER ANGLE BACKING PLATE
2	2	2000533	CROSSOVER BRAKE SHAFT PIVOT ANGLE
3	1	2000532	BRAKE PEDAL CROSS SHAFT
4	1	200287	PASSENGER SIDE BRAKE PEDAL LINKAGE ARM WELDMENT
5	1	200288	DRIVER SIDE BRAKE PEDAL LINKAGE ARM WELDMENT
6	2	2000546	KEYSTOCK 3/16x1
7	1	51551	3/8OD x 3/8 ROLLER BEARING
8	1	51552	3/8 x 3/4 COILED PIN
9	1	200286	BRAKE PEDAL INNER SCAB WELDMENT
10	1	2000537	BRAKE PEDAL OUTER SCAB PLATE
11	1	2000548	BRAKE ARM BRACKET MODIFIED
12	1	2000549	BRAKE ARM MODIFIED
13	2	40180	5/16-18 x 7/8" FLAST SOCKET CAP HEX SCREW
14	2	40181	M8X1.25 FLANGE NUT WITH SERRATIONS
15	2	51502	BRAKE ARM BUSHING
16	1	51503	BRAKE ARM PIN
17	1	51504	NUT FOR BRAKE ARM PIN
18	1	51505	BRAKE ARM RETURN SPRING
19	1	51506	PEDAL COVER
20	2	51507	FLANGE BOLT WITH WASHER

STEERING COLUMN ASSEMBLY; PASSENGER SIDE

EXPLODED VIEW PART #300281

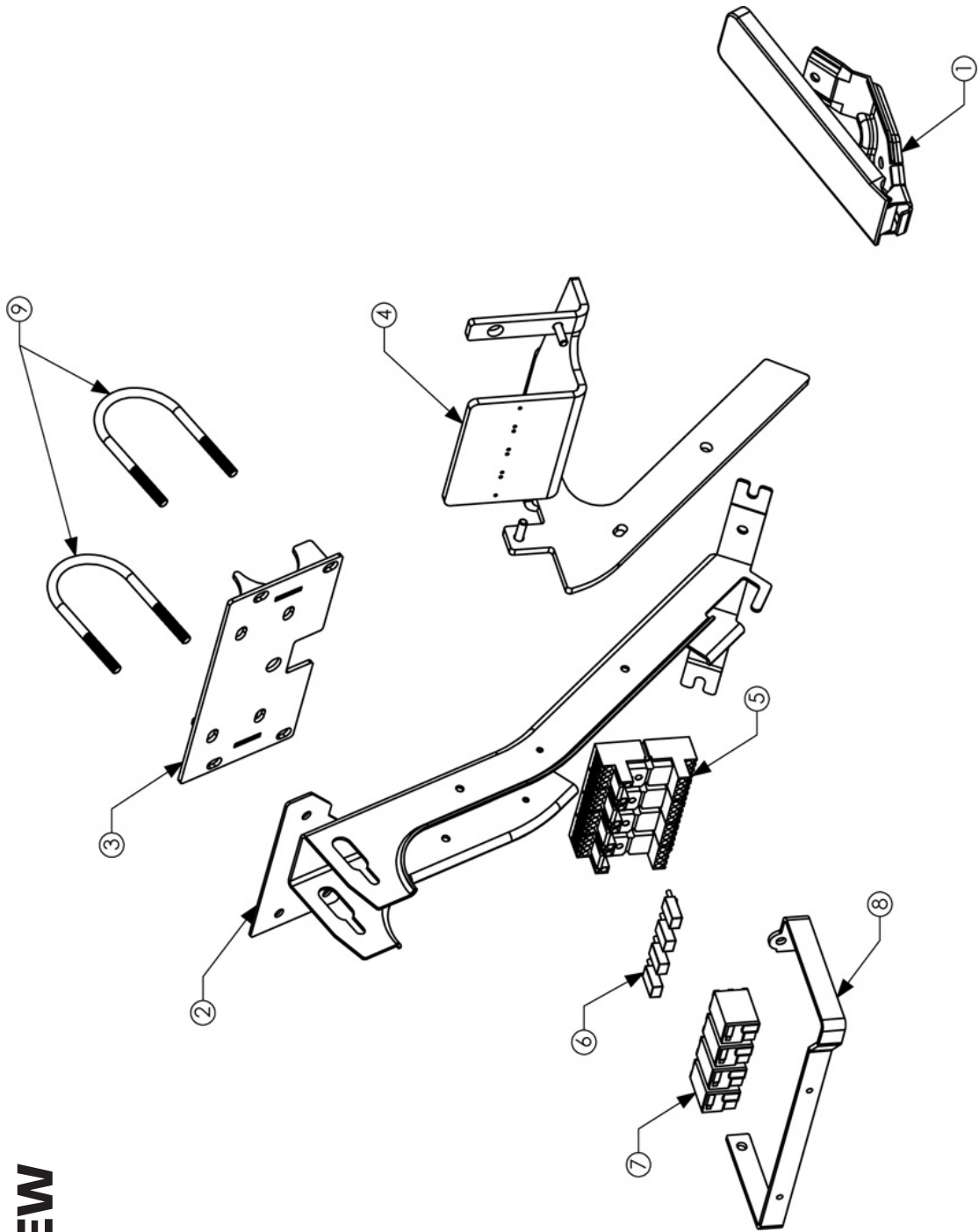

STEERING COLUMN ASSEMBLY; PASSENGER SIDE

PARTS REQUIREMENTS

ITEM NO.	QTY.	PART NUMBER	DESCRIPTION
1	1	2000550	GAS PEDAL ASSY MODIFIED
2	1	2000547	STEERING COLUMN MODIFIED
3	1	200285	UPPER STEERING MOUNT WELDMENT
4	1	200284	PASSENGER SIDE COLUMN BRACE WELDMENT
5	4	51546	SCHNEIDER RXZE2M114M RELAY BASE
6	4	51548	SCHNEIDER RXM040W DIODE
7	4	51545	SCHNEIDER RXM4A82JD RELAY
8	1	2000539	RELAY GUARD DUAL STEERING
9	2	51565	2" x 5/16 U-BOLT
10	8	40177	SCREWS M3 x .5 x 25MM
11	4	51547	RELAY HOLD WIRES
12	1	51561	DUAL STEER ACCESSORY HARNESS
13	1	51562	DUAL STEER ACCELERATOR PEDAL HARNESS
14	2	51508	INTERIOR PLUG, GREY

SEAT ASSEMBLY
EXPLODED VIEW
PART #300279

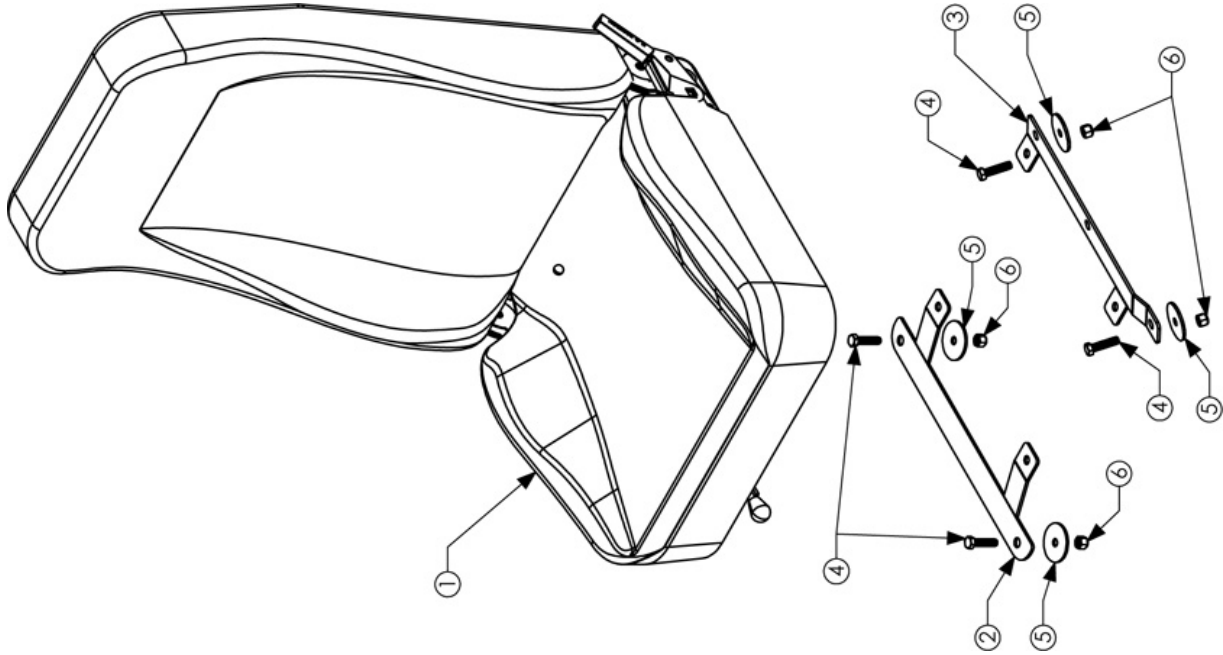

SEAT ASSEMBLY

PARTS REQUIREMENTS

ITEM NO.	QTY.	PART NUMBER	DESCRIPTION
1	1	51540	SEAT 3329-4000
2	1	2000530	PASSENGER SEAT OUTER MOUNTING BRACKET
3	1	2000531	PASSENGER SEAT OUTER MOUNTING BRACKET
4	4	40002	SCREW HHSC 3/8-16 X 1-1/2 G5
5	4	40179	3/8 LARGE DIAMETER FENDER WASHER 1/8 THICK
6	4	40013	NUT LOC 3/8-16

AC CONDENSER POWER STEERING ASSEMBLY

**EXPLODED VIEW
PART #300279**

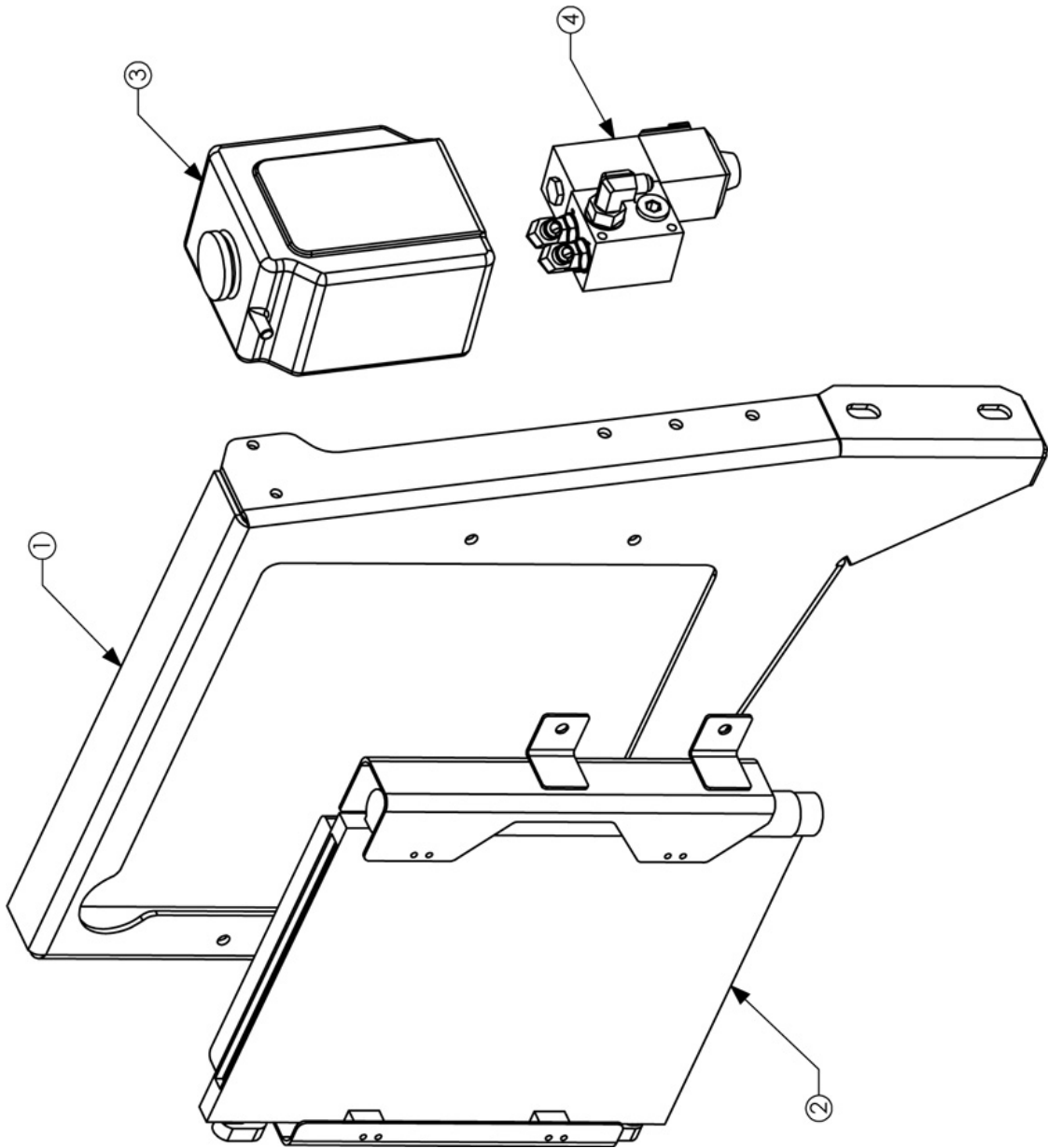

AC CONDENSER POWER STEERING ASSEMBLY

ITEM NO.	QTY.	PART NUMBER	DESCRIPTION
1	1	2001109	AC COOLER MOUNTING BRACKET IZUSU 2009
2	1	OEM	ISUZU 2009 AC CONDENSOR
3	1	50029	OVERFLOW BOTTLE
4	1	300277	DUAL STEERING MANIFOLD ASSY
5	1	300246	DUAL STEER HIGH PRESSURE A/C LINE MODIFIED
6	1	300247	DUAL STEER LOW PRESSURE A/C LINE MODIFIED
7		51544	HOSE, WINDSHIELD WASHER

HYDRAULIC SCHEMATIC

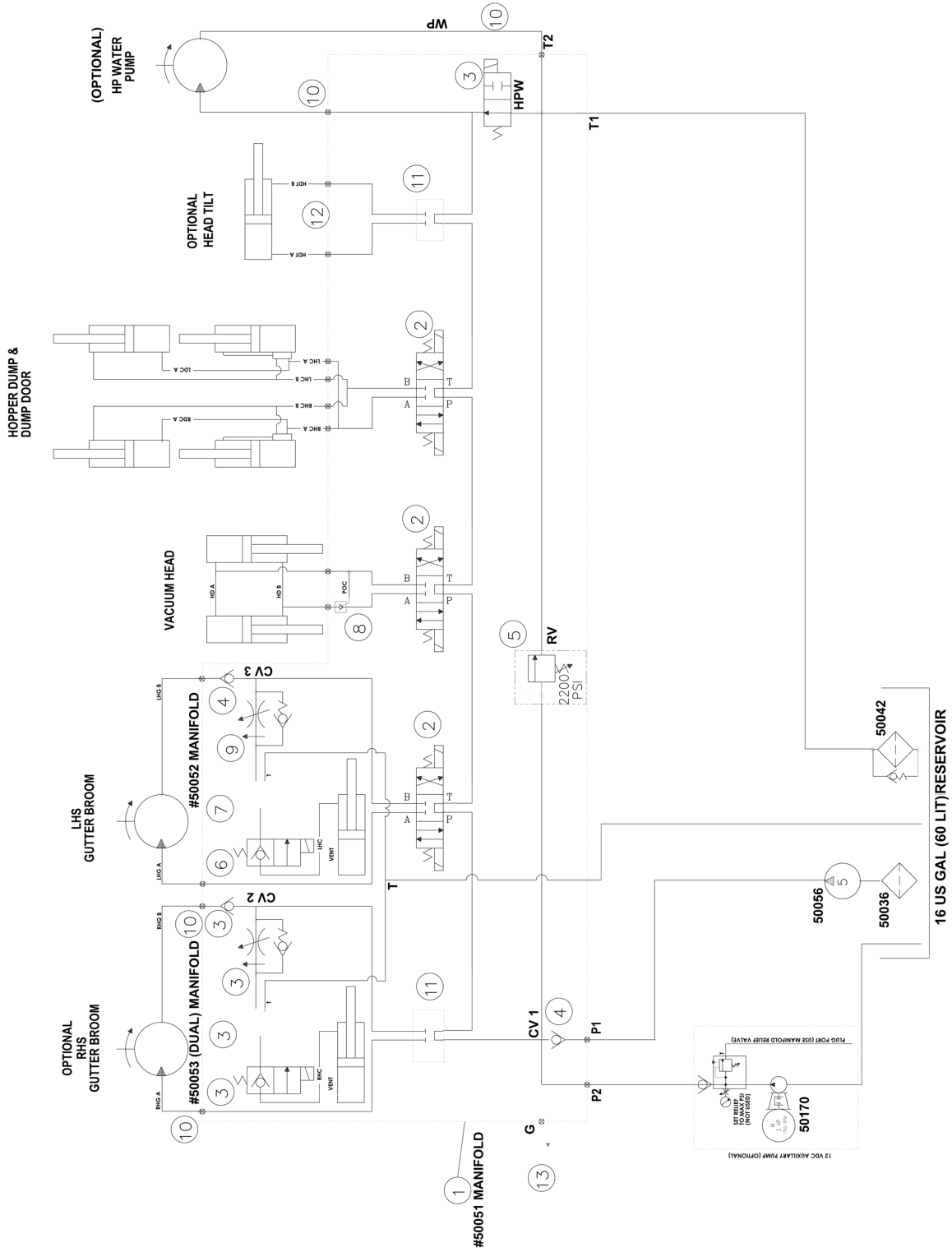

ELECTRICAL SCHEMATICS

PAGE 1 OF 2

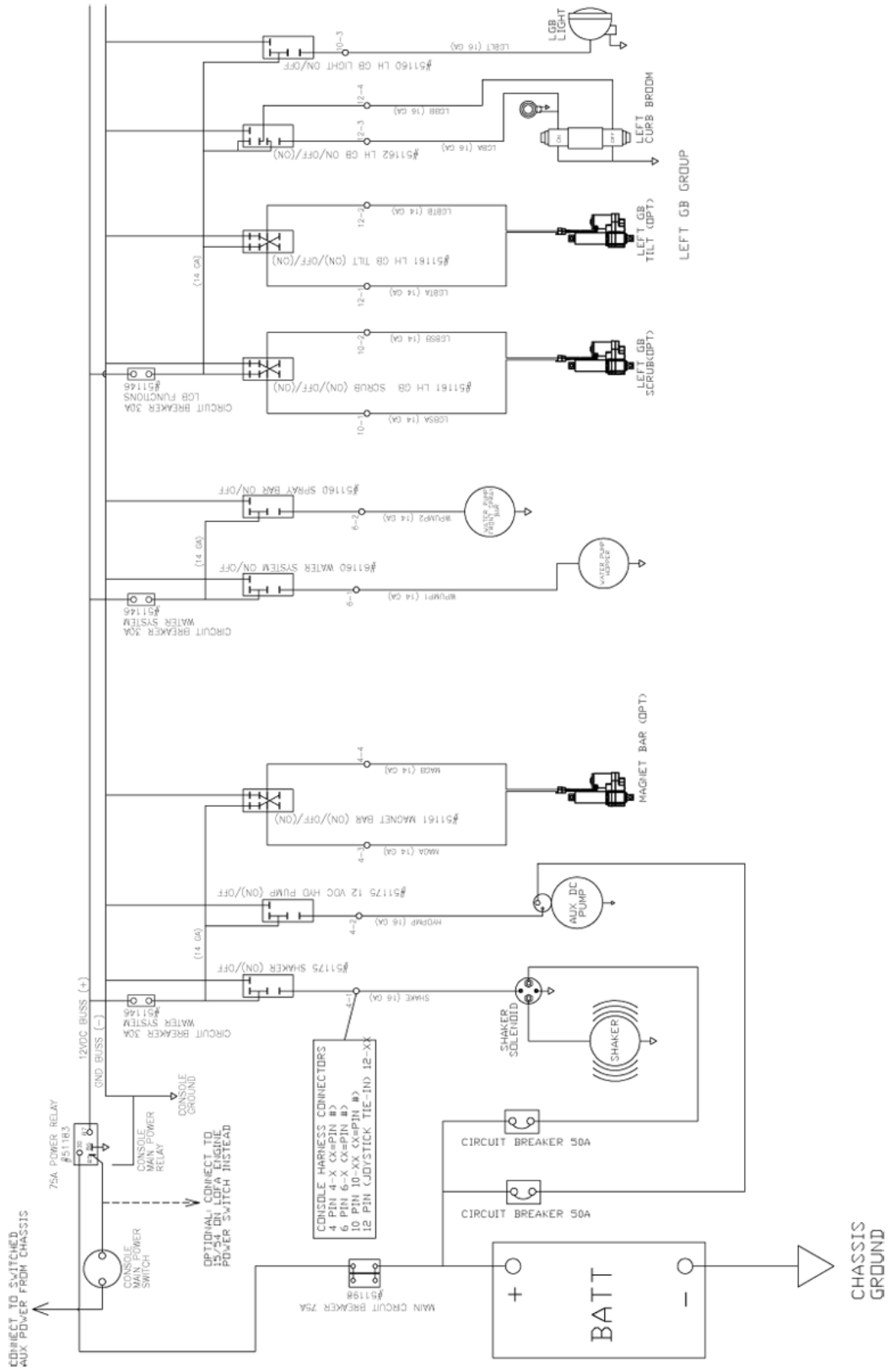

ELECTRICAL SCHEMATICS

PAGE 2 OF 2

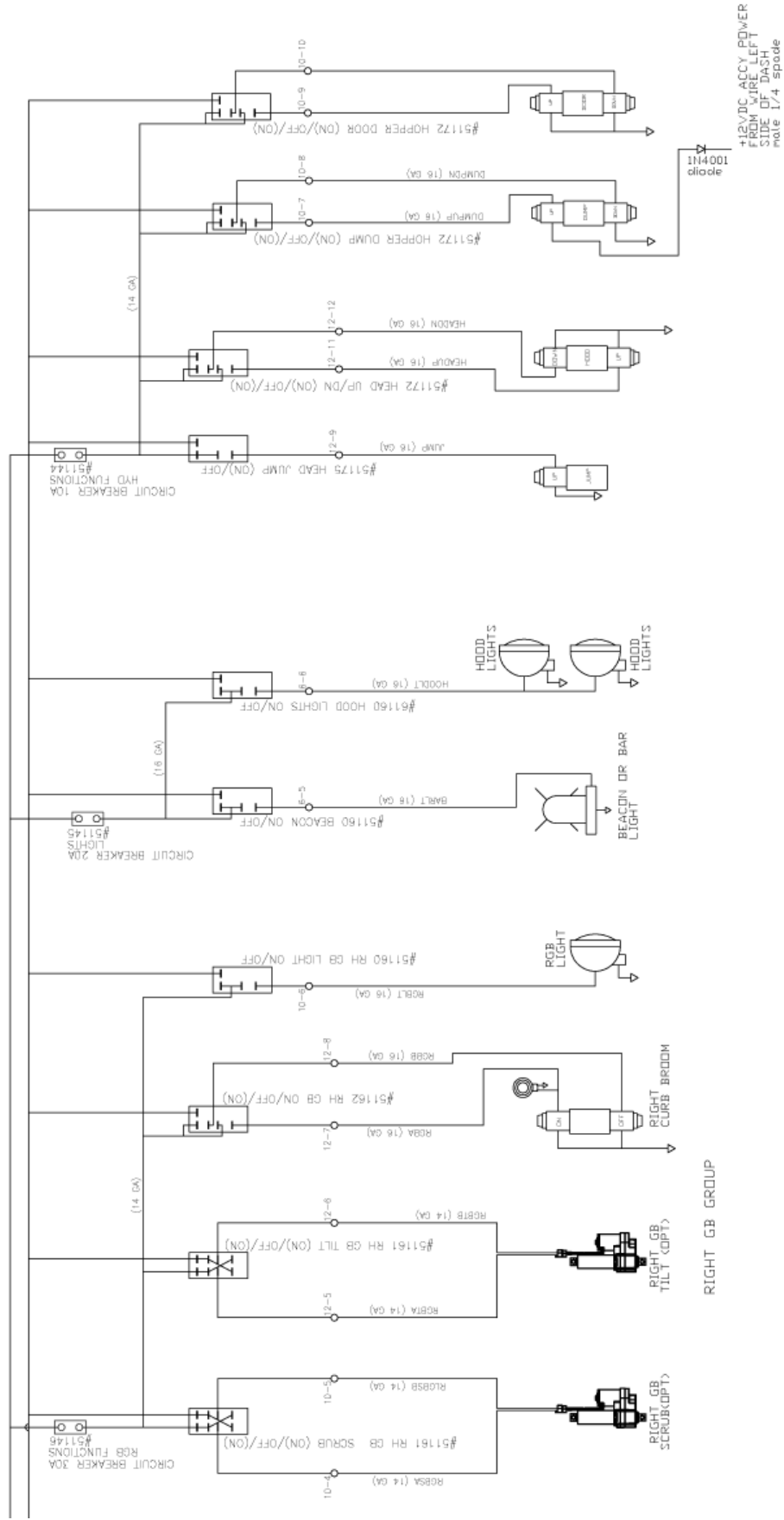

CONTROL AND WIRING HARNESS

PAGE 1 OF 1

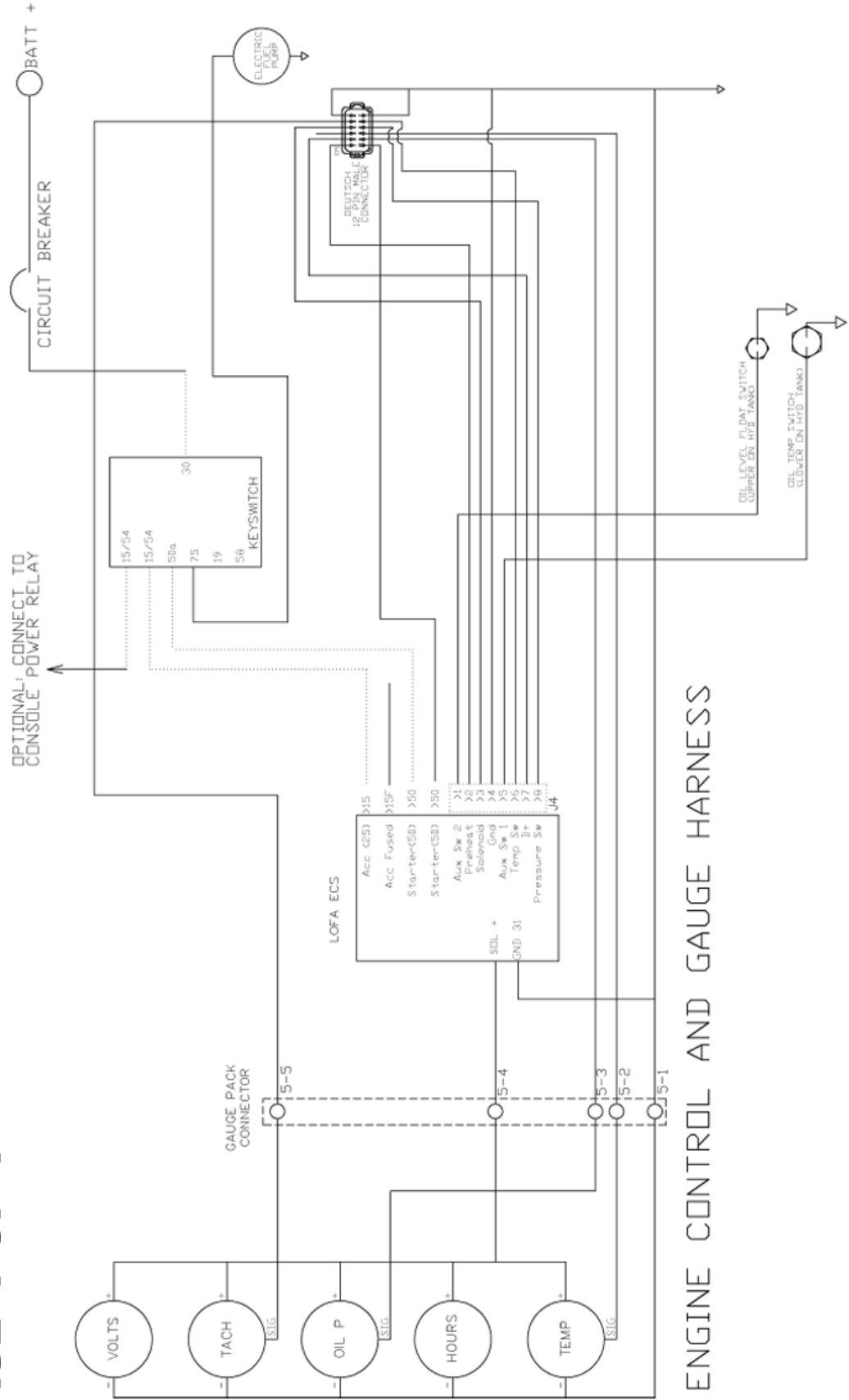

NOTES:
