

SC6000

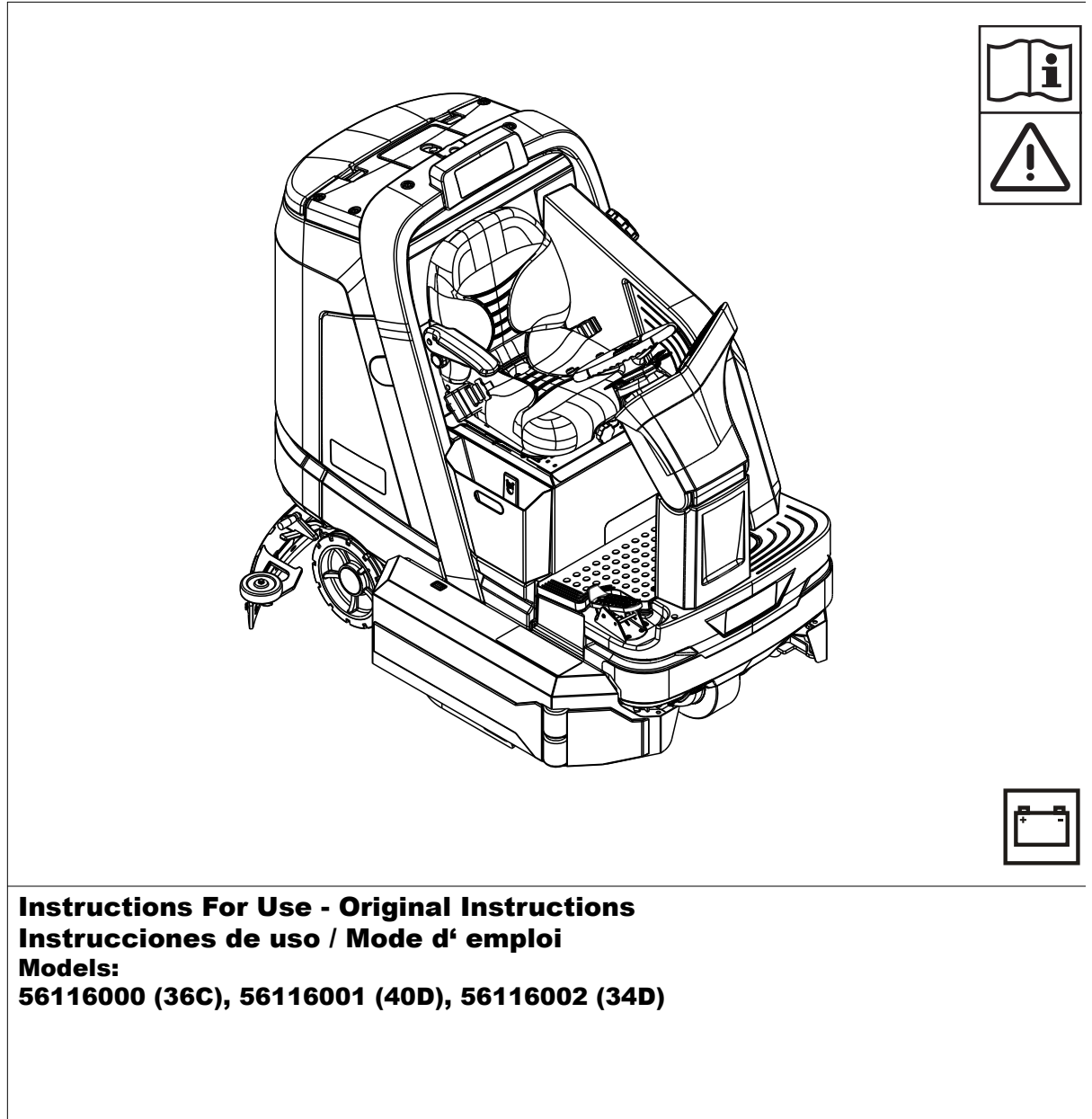

Instructions For Use - Original Instructions
Instrucciones de uso / Mode d'emploi
Models:
56116000 (36C), 56116001 (40D), 56116002 (34D)

A-English
B-Español
C-Français



TABLE OF CONTENTS

	page
Introduction.....	A-3
Cautions and Warnings	A-4 – A-5
Know Your Machine.....	A-6 – A-7
Control Panel.....	A-8 – A-9
Information Menu Display.....	A-10 – A-11
Prepare the Machine for Use	
Install the Batteries.....	A-12 – A-13
Install the Brushes.....	A-14 – A-15
Fill the Solution Tank.....	A-16
Squeegee Installation.....	A-17
Detergent System.....	A-18 – A-19
Operating the Machine	
Operating the Machine.....	A-20 – A-21
Scrubbing	A-20
Wet Vacuuming	A-21
After Use.....	A-22
Maintenance Schedule.....	A-22
Lubricating the Machine.....	A-23
Electromagnetic Brake.....	A-23
Charging the Batteries.....	A-24 – A-25
Check the Battery Water Level.....	A-24
Squeegee Maintenance.....	A-26 – A-27
Squeegee Adjustment.....	A-26 – A-27
Side Blade Maintenance.....	A-28 – A-29
Troubleshooting	
Troubleshooting.....	A-30 – A-33
Fault Code Display.....	A-31 – A-33
Accessories Options.....	A-34
Material Composition and Recyclability.....	A-34
Solution Flow Rates.....	A-34
Technical Specifications	A-34 – A-35

CAUTION!

- Use extreme CAUTION when operating this machine. Be certain that you are thoroughly familiar with all operating instructions before using this machine. If you have any questions, contact your supervisor or your local Advance Industrial Dealer.
- If the machine malfunctions, do not try to correct the problem unless your supervisor directs you to do so. Have a qualified company mechanic or an authorized Advance Dealer service person make any necessary corrections to the equipment.
- Use extreme care when working on this machine. Loose clothing, long hair, and jewelry can get caught in moving parts. Turn the Power Switch OFF and remove the magnetic key before servicing the machine. Use good common sense, practice good safety habits and pay attention to the yellow decals on this machine.
- Drive the machine slowly on inclines. DO NOT turn the machine on an incline; drive straight up or down.
- The maximum rated incline for scrubbing is 12.2% (7°). The maximum rated incline during transport is 18.5% (10.5°).

INTRODUCTION

This manual will help you get the most from your Advance Rider Scrubber. Read it thoroughly before operating the machine.

Note: Bold numbers in parentheses indicate an item illustrated on pages A-6 – A-9.

This product is intended for commercial use only.

PARTS AND SERVICE

Repairs, when required, should be performed by your Authorized Advance Service Center, who employs factory trained service personnel, and maintains an inventory of Advance original replacement parts and accessories.

Call the ADVANCE DEALER named below for repair parts or service. Please specify the Model and Serial Number when discussing your machine.

MODIFICATIONS

Modifications and additions to the cleaning machine which affect capacity and safe operation shall not be performed by the customer or user without prior written approval from Nilfisk, Inc. Unapproved modifications will void the machine warranty and make the customer liable for any resulting accidents.

NAMEPLATE

The Model Number (also known as Part Number) and Serial Number of your machine are shown on the Nameplate, located on the steering column of the machine. This information is needed when ordering repair parts for the machine. Use the space below to note the Part Number and Serial Number of your machine for future reference.

PART NO. _____

SERIAL NO. _____

UNCRATE THE MACHINE

When the machine is delivered, carefully inspect the shipping packaging and the machine for damage. If damage is evident, save the shipping carton (if applicable) so that it can be inspected. Contact the Advance Customer Service Department immediately to file a freight damage claim. Refer to the unpacking instruction sheet included with the machine to remove the machine from the pallet.

WARNING!

The Products sold with this Manual contain or may contain chemicals that are known to certain governments (such as the State of California, as identified in its Proposition 65 Regulatory Warning Law) to cause cancer, birth defects or other reproductive harm. In certain locations (including the State of California) purchasers of these Products that place them in service at an employment job site or a publicly accessible space are required by regulation to make certain notices, warnings or disclosures regarding the chemicals that are or may be contained in the Products at or about such work sites. It is the purchaser's responsibility to know the content of, and to comply with, any laws and regulations relating to the use of these Products in such environments. The Manufacturer disclaims any responsibility to advise purchasers of any specific requirements that may be applicable to the use of the Products in such environments.

TRANSPORTING THE MACHINE

CAUTION!

Before transporting the machine on an open truck or trailer, make sure that . . .

- All tanks are empty.
- All access doors are latched securely.
- The machine is tied down securely - see Tie Down Point locations (25).
- The machine's electromagnetic brake is engaged (not manually overridden).
- Lower the scrub deck and squeegee then press Emergency Stop Switch (U) or disconnect batteries to prevent them from raising when the machine is powered off.
- The machine is turned off and the magnetic smart key is removed.

CAUTIONS AND WARNINGS

SYMBOLS

Advance uses the symbols below to signal potentially dangerous conditions. Always read this information carefully and take the necessary steps to protect personnel and property.

This machine is for commercial use, for example in hotels, schools, hospitals, factories, shops and offices other than normal residential housekeeping purposes.

DANGER!

Is used to warn of immediate hazards that will cause severe personal injury or death.

WARNING!

Is used to call attention to a situation that could cause severe personal injury.

CAUTION!

Is used to call attention to a situation that could cause minor personal injury or damage to the machine or other property.



Read all instructions before using.

GENERAL SAFETY INSTRUCTIONS

Specific Cautions and Warnings are included to warn you of potential danger of machine damage or bodily harm.

WARNING!

- This machine shall be used only by properly trained and authorized persons.
- This machine is not intended for use by persons (including children) with reduced physical, sensory or mental capabilities, or lack of experience and knowledge, unless they have been given supervision or instruction concerning use of the machine by a person responsible for their safety.
- Children should be supervised to ensure that they do not play with the machine.
- Close attention is necessary when used near children.
- While on ramps or inclines, avoid sudden stops. Avoid abrupt sharp turns. Use low speed down ramps.
- Keep sparks, flame and smoking materials away from batteries. Explosive gases are vented during normal operation.
- Charging the batteries produces highly explosive hydrogen gas. Charge batteries only in well-ventilated areas, away from open flame. Do not smoke while charging the batteries.
- Remove all jewelry when working near electrical components.
- Turn the power switch off, remove the magnetic key and disconnect the batteries before servicing electrical components.
- Never work under a machine without safety blocks or stands to support the machine.
- Do not dispense flammable cleaning agents, operate the machine on or near these agents, or operate in areas where flammable liquids exist.
- Do not pressure wash operator control panel, circuit breaker panel or batteries.
- Only use the brushes provided with the appliance or those specified in the instruction manual. The use of other brushes may impair safety.
- Observe the Gross Vehicle Weight, GVW, of the machine when loading, driving, lifting or supporting the machine.
- Do not use the machine without a falling object protective structure (FOPS) in areas where it is likely that the operator is hit by falling objects.
- Do not leave the machine unattended without being sure that it cannot move independently.

 CAUTION!

- This machine is not approved for use on public paths or roads.
- This machine is not suitable for picking up hazardous dust.
- Do not use scarifier discs and grinding stones. Advance will not be held responsible for any damage to floor surfaces caused by scarifiers or grinding stones (can also cause damage to the brush drive system).
- When operating this machine, ensure that third parties, particularly children, are not endangered.
- Before performing any service function, carefully read all instructions pertaining to that function.
- Do not leave the machine unattended without first turning the power switch off and removing the magnetic key.
- Turn the power switch off and remove the magnetic key, before changing the brushes, and before opening any access panels.
- Take precautions to prevent hair, jewelry, or loose clothing from becoming caught in moving parts.
- Use caution when moving this machine in below freezing temperature conditions. Any water in the solution, recovery or detergent tanks or in the hose lines could freeze, causing damage to valves and fittings. Flush with windshield washer fluid.
- The batteries must be removed from the machine before the machine is scrapped. The disposal of the batteries should be safely done in accordance with your local environmental regulations.
- Do not use on surfaces having a gradient exceeding that marked on the machine.
- All doors and covers are to be positioned as indicated in the instruction manual before using the machine.
- The machine's magnetic smart key has a built-in magnet. Do not place objects having magnetic bands (such as credit cards, electronic keys, phone cards) near the key. The built-in magnet can damage or erase the data stored on the magnetic bands.

SAVE THESE INSTRUCTIONS

KNOW YOUR MACHINE

As you read this manual, you will occasionally run across a bold number or letter in parentheses - example: (2). These numbers refer to an item shown on these pages unless otherwise noted. Refer back to these pages whenever necessary to pinpoint the location of an item mentioned in the text. **NOTE:** Refer to the service manual for detailed explanations of each item illustrated on the next 4 pages.

- | | | | |
|---|--|----|---|
| 1 | Recovery Tank Cover | 10 | Machine Battery Connector |
| 2 | Operator's Seat (adjustable) | 11 | Headlights (optional) |
| 3 | Drive Pedal, Directional/Speed | 12 | Onboard Battery Charger (optional) |
| 4 | Drive and Steer Wheel | 13 | Cup Holder |
| 5 | Rear Wheel | 14 | Fuse Holder Boot (Main Fuse 150 Amp) |
| 6 | Battery Compartment | 15 | Scrub Deck Side Door |
| 7 | Waste Bin | 34 | Left Side Access Grip |
| 8 | Detergent Cartridge (EcoFlex models only) | 35 | Step |
| 9 | Seat Prop Rod | | |

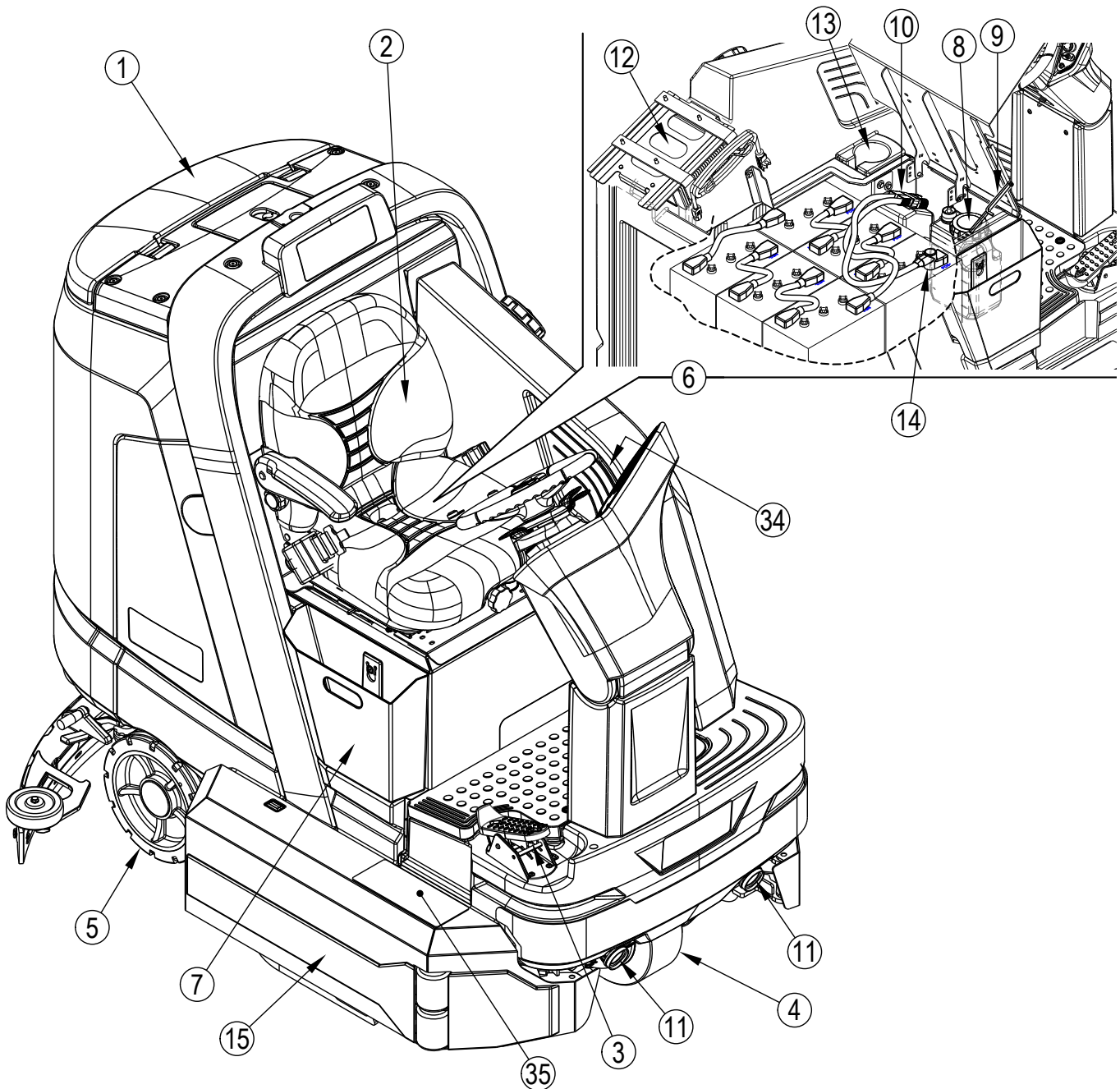

KNOW YOUR MACHINE

- | | | | |
|----|----------------------------------|----|---------------------------|
| 15 | Scrub Deck Side Door | 25 | Tie-Down Location |
| 16 | Steering Column Tilt Adjust | 26 | Hopper (cylindrical only) |
| 17 | Recovery Filter and Screen Cover | 27 | Scrub Deck |
| 18 | Debris Catch Tray | 28 | Control Panel |
| 19 | Recovery Tank Full Switch | 29 | Solution Filter |
| 20 | Recovery Tank Drain Hose | 30 | Solution Shutoff Valve |
| 21 | Squeegee Removal Knob | 31 | Solution Tank Drain Hose |
| 22 | Squeegee Tilt Adjust Knob | 32 | Solution Tank Fill |
| 23 | Squeegee Height Adjust Knob | 33 | Squeegee Hose |
| 24 | Squeegee Assembly | 36 | Squeegee Hook |

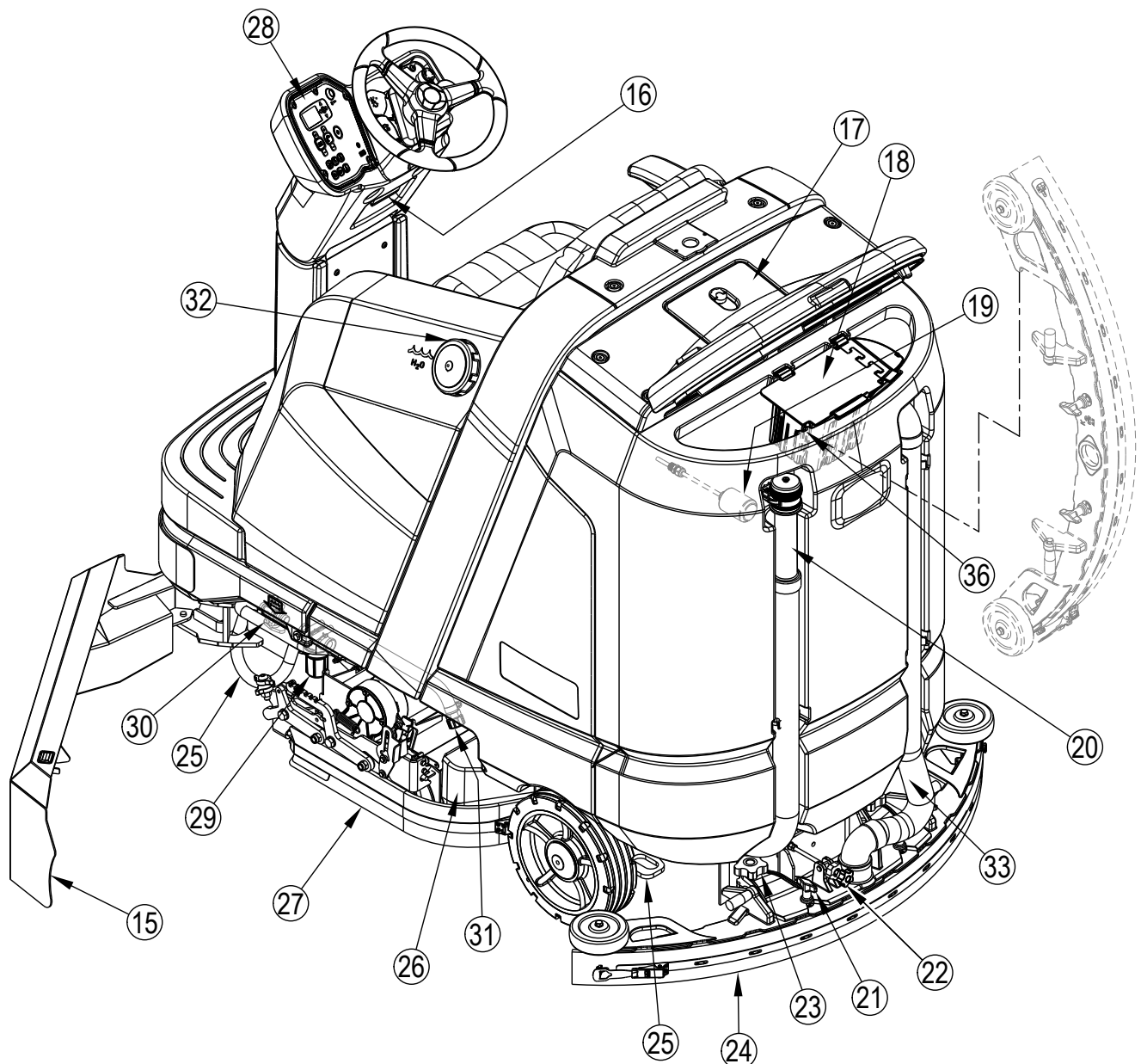

CONTROL PANEL

- | | |
|---|--|
| A Smart Key Reader | M Headlight Switch (optional) |
| B Power Switch | N Speed Limiter Switch |
| C Display | O Brush Install Switch |
| D Information Switch and Navigation Switches | P Dust Guard™ Switch (optional) |
| E One-Touch™ Scrub Switch | Q Detergent Switch |
| F Scrub Pressure Increase Switch | R Timed Solution Off Paddle |
| G Scrub Pressure Decrease Switch | S Burst of Power Paddle |
| H Solution Switch | T Horn Paddle |
| J Solution Flow Increase Switch | U Emergency Stop Switch |
| K Solution Flow Decrease Switch | V Control Circuit Breaker |
| L Vacuum / Wand Switch | W Magnetic Smart Key |
- Blue = User
-Yellow = Supervisor

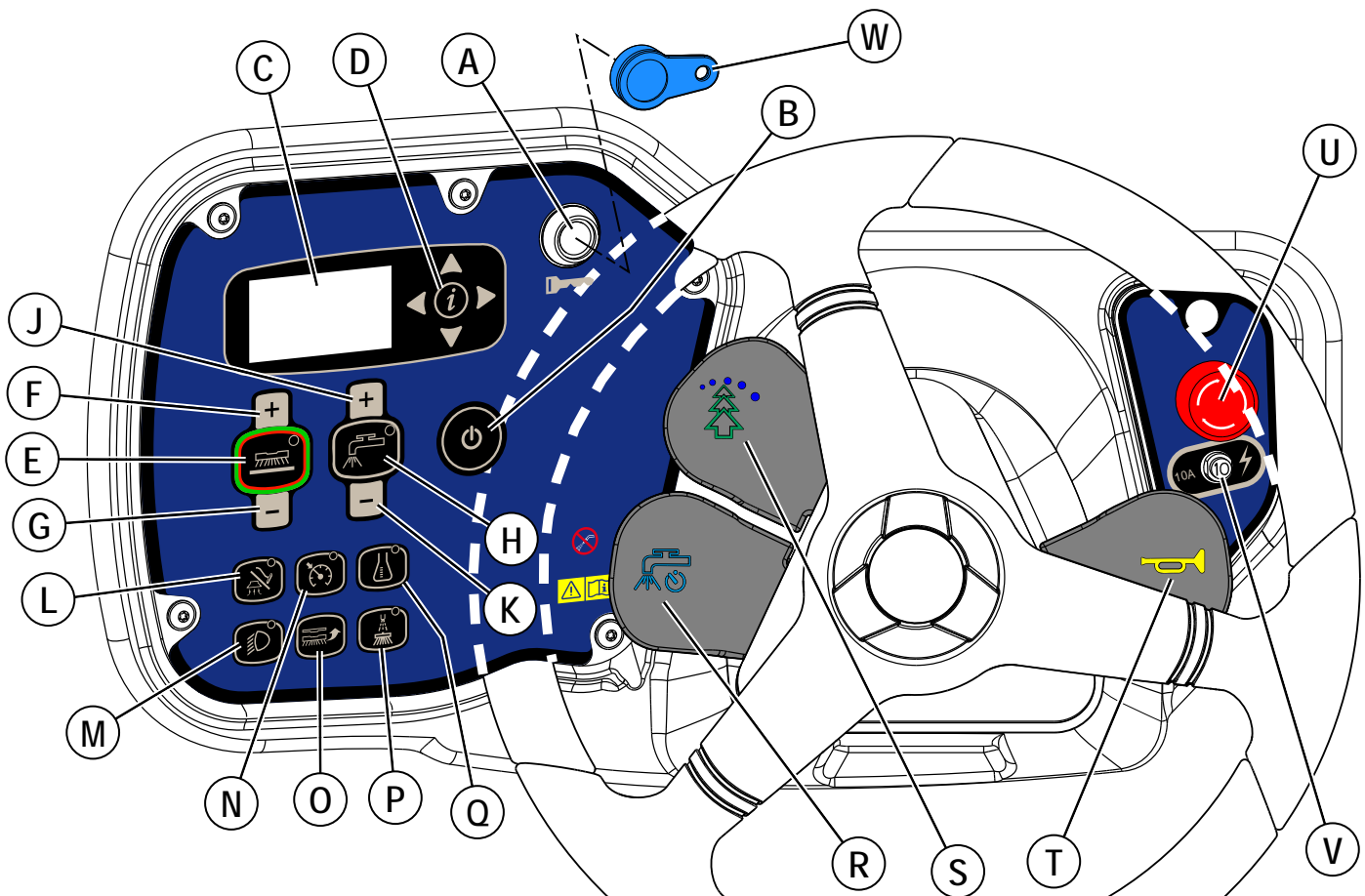

CONTROL PANEL - CONTINUED

- C1 Hour Meter (Drive Hours)
- C2 Active Fault Codes
- C3 Battery Indicator
- C4 Solution Tank Level Indicator
- C5 Speed (miles per hour)
- C6 Detergent Indicator (if so equipped)
- C7 Detergent Ratio Indicator
- C8 Detergent Indicator Bar Graph
 - FIRST = Minimum Concentration Detergent Mode
 - SECOND = Maximum Concentration Detergent Mode
 - NONE = Off
- C9 Solution Flow Indicator
- C10 Solution Flow Rate Bar Graph
 - FIRST = Low
 - SECOND = Medium
 - THIRD = High
 - FOURTH = Extreme
 - NONE = Off
- C11 Scrub Pressure Indicator
- C12 Scrub Brush Pressure Bar Graph
 - FIRST = Regular
 - SECOND = Heavy
 - THIRD = Extreme
 - NONE = Off
- C13 Recovery Tank Full Indicator
- C14 Battery Low Voltage Indicator
- C15 Burst of Power Indicator (EcoFlex models only)
- C16 Vacuum Indicator
- C17 Wand Indicator
- C18 Brush Install Indicator
- C19 Purge Indicator (EcoFlex models only)
- C20 Emergency Stop Activated Indicator
- C21 No Key Indicator
- C22 Key Read Error Indicator (see Troubleshooting)
- C23 Restricted User Key Indicator (see Troubleshooting)
- C24 Critical Fault Indicator
- C25 Fault Code (Critical)
- C26 Impact Lockout Indicator (see page 11)

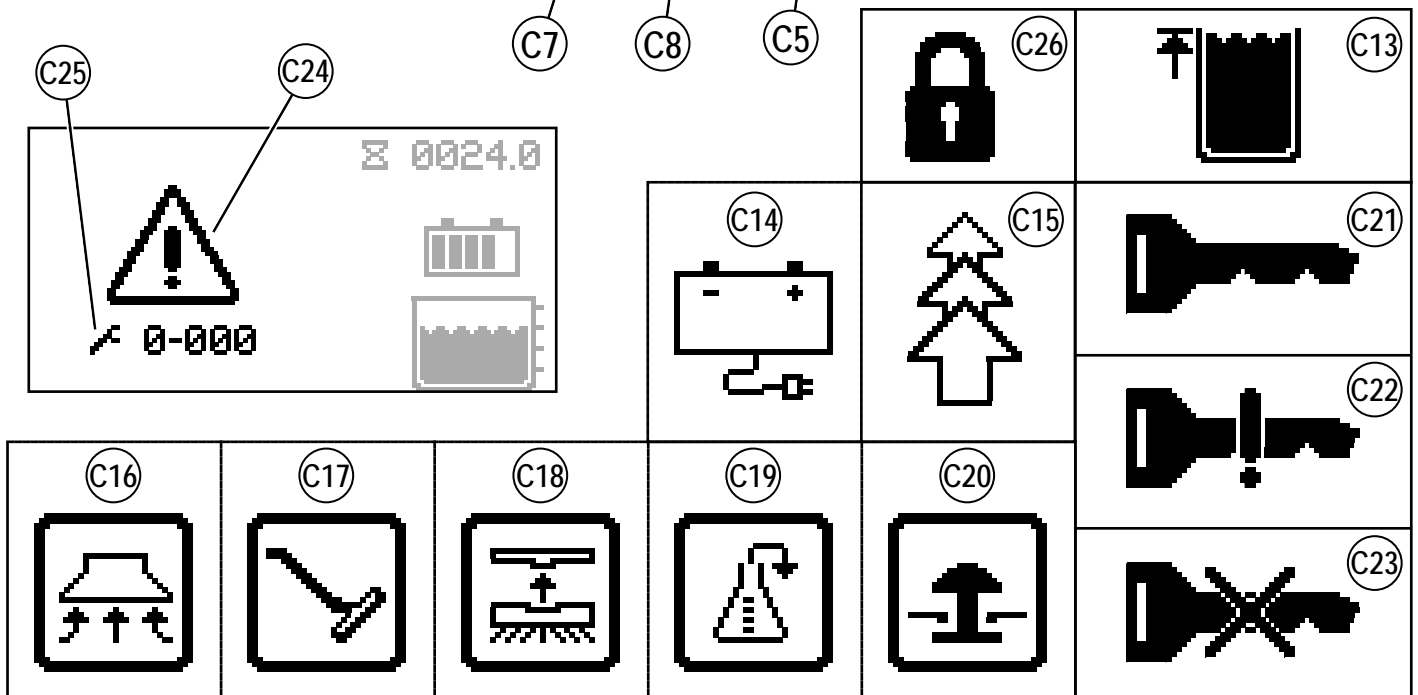
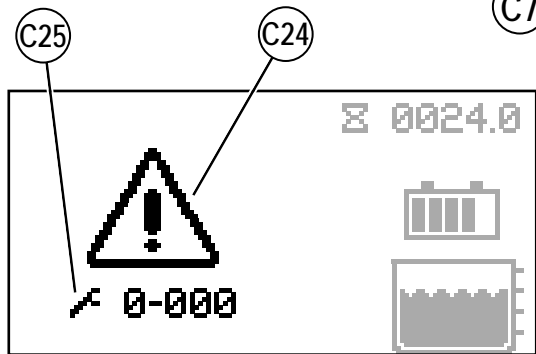
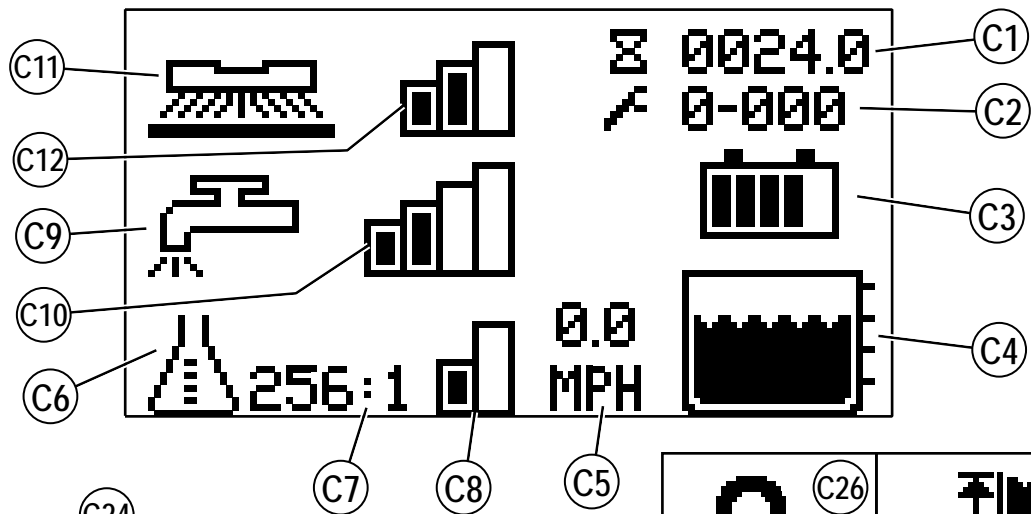

INFORMATION MENU DISPLAY

Menu Display

Pressing the Information Switch (**D**) will bring up the menu shown below which allows the operator to change machine settings and gather machine information. Use the four Navigation Arrows (**D1**) (up, down, left & right) to move through the menu and the information switch to exit the menu.

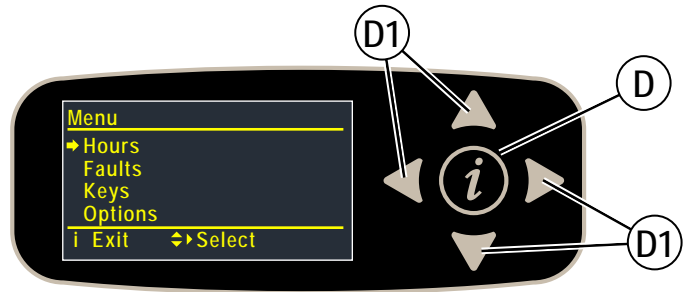

Menu Level		Notes
1	2	
Hours		Displays various system hours
	On Time	Displays Power ON hours
	Drive Time	Displays drive(non-neutral) hours
	Scrub Time	Displays scrub/brush ON hours
	Recovery Time	Displays recovery/vacuum ON hours
Faults**		
	Active Faults	Displays list of active faults w/timestamp and description
	Fault History	Displays list of fault history w/timestamp and description
Keys		
	Read Key	Read the key serial number, family and type for key inserted into holder - if user key, allows supervisor to add to key list
	Key List	Display the current approved user key list supervisor can also remove selected key from list

**See Fault Code Display

Menu Level			Notes
1	2	3	
Options			User selectable options
	Language	English* Italiano Deutsch Portuguese Français Español	Menu display language
	Floor	Standard* Smooth	Floor type
	Scrub Startup	Light Heavy Extreme Last*	Scrub level at start
	Scrub Max	Light Heavy Extreme*	Maximum scrub level allowed

*Default setting

INFORMATION MENU DISPLAY - CONTINUED

Menu Level			Notes
1	2	3	
Options			User selectable options
	Solution	Proportional* Fixed UK	Solution mode; Proportional – solution flow increases with speed of machine. Fixed – Solution flow stays the same despite machine speed. UK (United Kingdom) – solution flow is reduced to conserve water.
	Solution In Rev	No* Yes	Leave solution on in reverse?
	Lock Detergent	No* Yes	Lockout detergent ratio adjustment for user?
	Headlight	On* Off	Headlight on/off at startup
	Burst Of Power (s)	min = 60* max = 300 step = 60	Burst-of-power (BOP) time span (seconds)
	Fwd Speed Max (%)	min = 50 max = 100* step = 10	Maximum forward speed as percentage of maximum available speed
	Lock Speed Limit	No* Yes	Lockout scrub speed limit for user?
	Inactivity Time (min)	min = 1 max = 30 step = 1 default = 15	Inactivity time before putting machine in sleep mode (minutes)
	Impact Detect	Off* Log Lockout	Impact detection status Log – Impact is recorded Lockout – Impact is recorded and User is locked out of scrub functions (Display shows (C26)) until machine is reset with a Supervisor key.
	Impact Level	High* Low	Impact detection sensitivity level. If nuisance tripping occurs (i.e. driving over a floor transition), adjust setting to low.
System			
	Firmware		Display current firmware revision
	Serial Num		Display PCB serial number from factory
	Impact Log		Display list of impact events with max value, timestamp and user id (only if enabled) - single item view will show max values for each axis (x,y,z)

*Default setting

MAGNETIC SMART KEY

The use of a Magnetic Smart Key (**W**) is required to operate this machine. Pressing the power switch without a key in place on the Smart Key Reader (**A**) will cause the machine to momentarily turn on and display No Key Indicator (**C21**) before turning off.

There are two different Magnetic Smart Keys (**W**).

1. The "User" (blue) key allows a basic level of access to the information menu (press Information Switch (**D**)).
2. The "Supervisor" (yellow) key allows an additional level of access. The service menu allows observing operational and user parameters. The configuration menu allows adjusting machine settings. See Service Manual for more details.

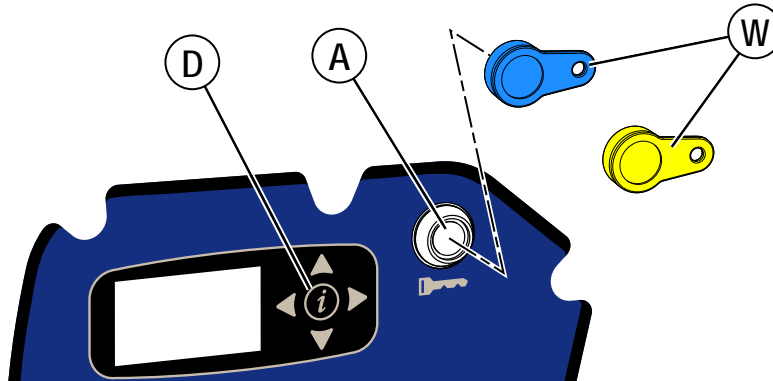

BATTERIES

If your machine shipped with batteries installed do the following:

- Check that the batteries are connected to the machine.
- Turn ON the Power Switch (**B**) and check the Battery Indicator (**C3**). If the gauge is completely filled the batteries are ready for use. If the gauge is less than full the batteries should be charged before use. See the "Charging The Batteries" section.
- **IMPORTANT!:** IF YOUR MACHINE HAS AN ONBOARD BATTERY CHARGER REFER TO THE OEM PRODUCT MANUAL FOR INSTRUCTIONS REGARDING SETTING THE CHARGER FOR BATTERY TYPE.

If your machine shipped without batteries installed do the following:

- Consult your Authorized Advance dealer for recommended batteries.
- Install the batteries by following the instructions below.
- **IMPORTANT!:** IF YOUR MACHINE HAS AN ONBOARD BATTERY CHARGER REFER TO THE OEM PRODUCT MANUAL FOR INSTRUCTIONS REGARDING SETTING THE CHARGER FOR BATTERY TYPE.

INSTALL THE BATTERIES

WARNING!

Use extreme caution when working with batteries. Sulfuric acid in batteries can cause severe injury if allowed to contact the skin or eyes. Explosive hydrogen gas is vented from the batteries through openings in the battery caps. This gas can be ignited by any electrical arc, spark or flame. Do not install any lead-acid battery in a sealed container or enclosure. Hydrogen gas from overcharging must be allowed to escape.

When Servicing Batteries...

- Remove all jewelry
- Do not smoke
- Wear safety glasses, rubber gloves and a rubber apron
- Work in a well-ventilated area
- Do not allow tools to touch more than one battery terminal at a time
- ALWAYS disconnect the negative (ground) cable first when replacing batteries to prevent sparks.
- ALWAYS connect the negative cable last when installing batteries.

BATTERIES - CONTINUED**⚠ CAUTION!**

Electrical components in this machine can be severely damaged if the batteries are not installed and connected properly. Batteries should be installed by Advance or by a qualified electrician.

- 1 Remove the batteries from their shipping crate and carefully inspect them for cracks or other damage. If damage is evident, contact the carrier that delivered them or the battery manufacturer to file a damage claim.
- 2 Turn the Power Switch **(B)** OFF and remove the magnetic key.
- 3 Raise the steering column to the full upright position. Tip the seat forward and engage the Seat Prop Rod **(9)**.
- 4 Remove the crossbar and if installed also remove the overhead guard.
- 5 Remove the recovery tank from the machine. **NOTE:** Disconnect the recovery switch wiring and the vacuum motor wiring then lift the tank straight up and off the machine.
- 6 Your machine comes from the factory with enough battery cables to install six 6 volt batteries. Using at least (2) people and an appropriate lifting strap, carefully lift the batteries into the battery compartment and arrange them exactly as shown in **FIGURE 1**. Secure the batteries as close to the front and right side of the machine as possible. Use battery spacer to keep batteries from moving. If installing a mono-block battery use an overhead hoist (the seat support bracket will need to be temporarily removed to install a mono-block battery).
- 7 Install the battery cables as shown. Position the cables so the battery caps can be easily removed for battery service.

IMPORTANT!: The protective caps supplied with the batteries need to be left on or re-used to completely cover the portion of the battery terminals that are not being protected by the battery cable terminal cover boots supplied with the battery cables. This also applies to the inline fuse holder boot.

- 8 Carefully tighten the nut in each battery terminal until the terminal will not turn. Do not over-tighten the terminals, or they will be very difficult to remove for future service.
- 9 Coat the terminals with spray-on battery terminal coating (available at most auto parts stores).
- 10 Put one of the black rubber boots over each of the terminals and connect the Machine Battery Connector **(10)**.
- 11 Make sure the Fuse Holder Boot **(14)** is covering the fuse holder, the cable end of the Machine Battery Connector **(10)**, and as much of the battery terminal as possible. Leave the protective caps supplied with the batteries in place or re-use to cover the terminal areas not protected by the terminal cover boots.

When changing batteries or the charger, please contact your local authorized service center for correct battery, charger and machine settings to prevent battery damage.

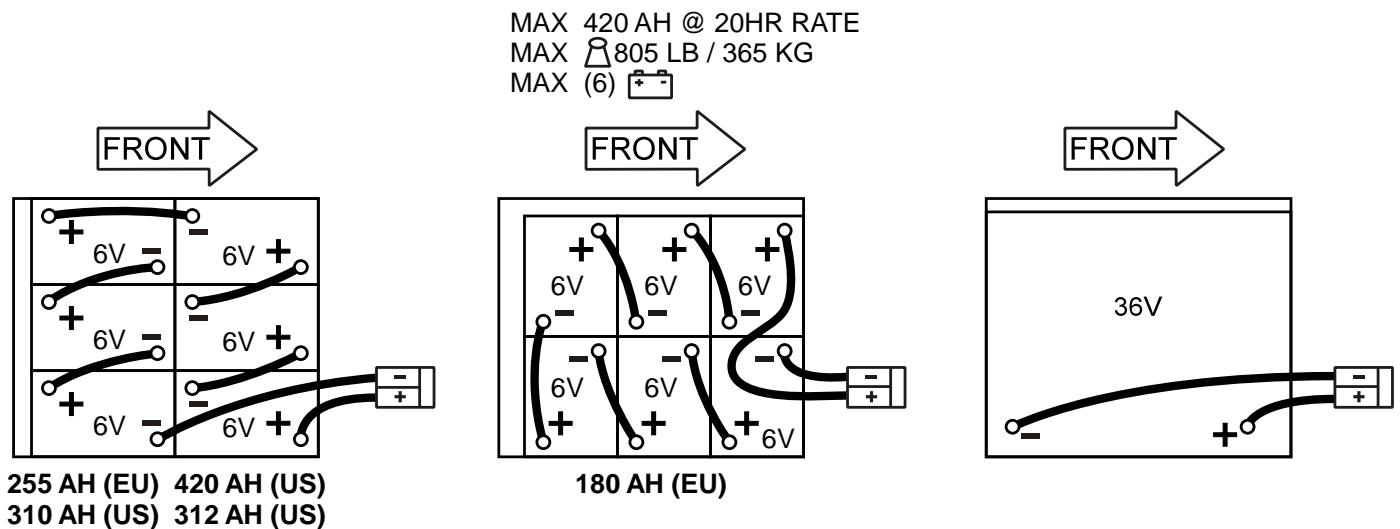
FIGURE 1

INSTALL THE BRUSHES (DISC SYSTEM)

⚠ CAUTION!

Turn the machine OFF at the power switch, before changing the brushes, and before opening any access panels.

- 1 Make sure the Scrub Deck is in the RAISED position. Make sure the Power Switch (B) is off.
- 2 Unlatch and swing open the Scrub Deck Side Doors (15).
- 3 **See Figure 2.** Remove both Side Blade Assemblies (AA). **NOTE:** The blades are held in place by a large Knob (BB). Loosen these knobs and slide the Blade Assemblies (AA) forward slightly and then off of the Scrub Deck.
- 4a **To manually install the brushes:**
Lift the Brushes (DD) (or pad holders) and align the lugs on the brush with the holes on the mounting plate then turn to lock in place (turn the outside edge of brush towards the front of machine as shown by arrow (EE)).
- 4b **To use the automatic Brush Install feature:**
 - i. Press the Guide Bar (CC) forward while sliding the brush under the deck and stop when the brush is contacting both legs of the guide bar. Repeat this step for the brush on the other side of the deck. **NOTE:** Do not push the first brush out of position with the second brush.
 - ii. Turn the machine ON at the Power Switch (B). **(SCRUB SYSTEM MUST BE OFF and MACHINE IN NEUTRAL)**

⚠ CAUTION!

Keep hands and feet out from underneath the deck. Take precautions to prevent hair, jewelry, or loose clothing from becoming caught in moving parts.

- iii. Press the Brush Install Switch (O) the display will show Brush Install Indicator (C18) then wait for the brush install sequence to finish.
- 5 Reinstall the side blade assemblies and close the deck side doors. **NOTE:** While scrubbing the brushes rotate as shown by arrow (FF).

FIGURE 2

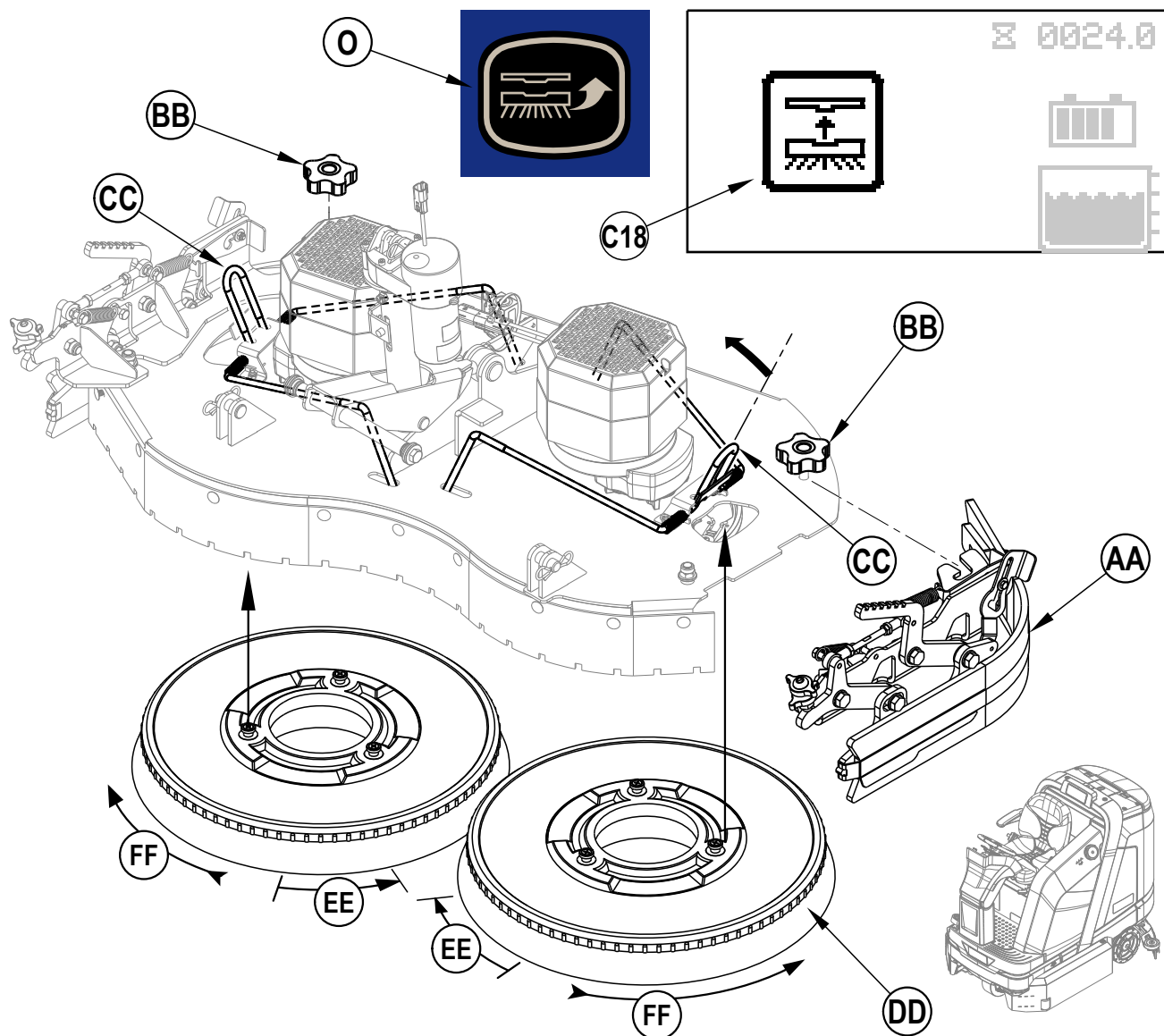

INSTALL THE BRUSHES (CYLINDRICAL SYSTEM)

⚠ CAUTION!

Turn the machine OFF at the power switch, before changing the brushes, and before opening any access panels.

- 1 Make sure the Scrub Deck is in the RAISED position. Make sure the Power Switch (B) is off.
- 2 Unlatch and swing open the Scrub Deck Side Doors (15).
- 3 See Figure 3. Unlatch and swing open both Side Blade Assemblies (AA).
- 4 Unhook the Latch (AB) on top of the Idler Assemblies (AC) and remove.
- 5 Slide the brush into the housing, lift slightly, push and turn until the tabs on the drive hub seat into the notches in the brush. NOTE: The idler is designed with a snug fit into the brush to reduce vibration. Re-install the Idler Assemblies (AC) make sure the tabs on the idler are inside of the weldment (as shown in Figure 3). Secure with Latch (AB). Close and latch both the Blade Assemblies (AA) and Scrub Deck Doors (15).

FIGURE 3

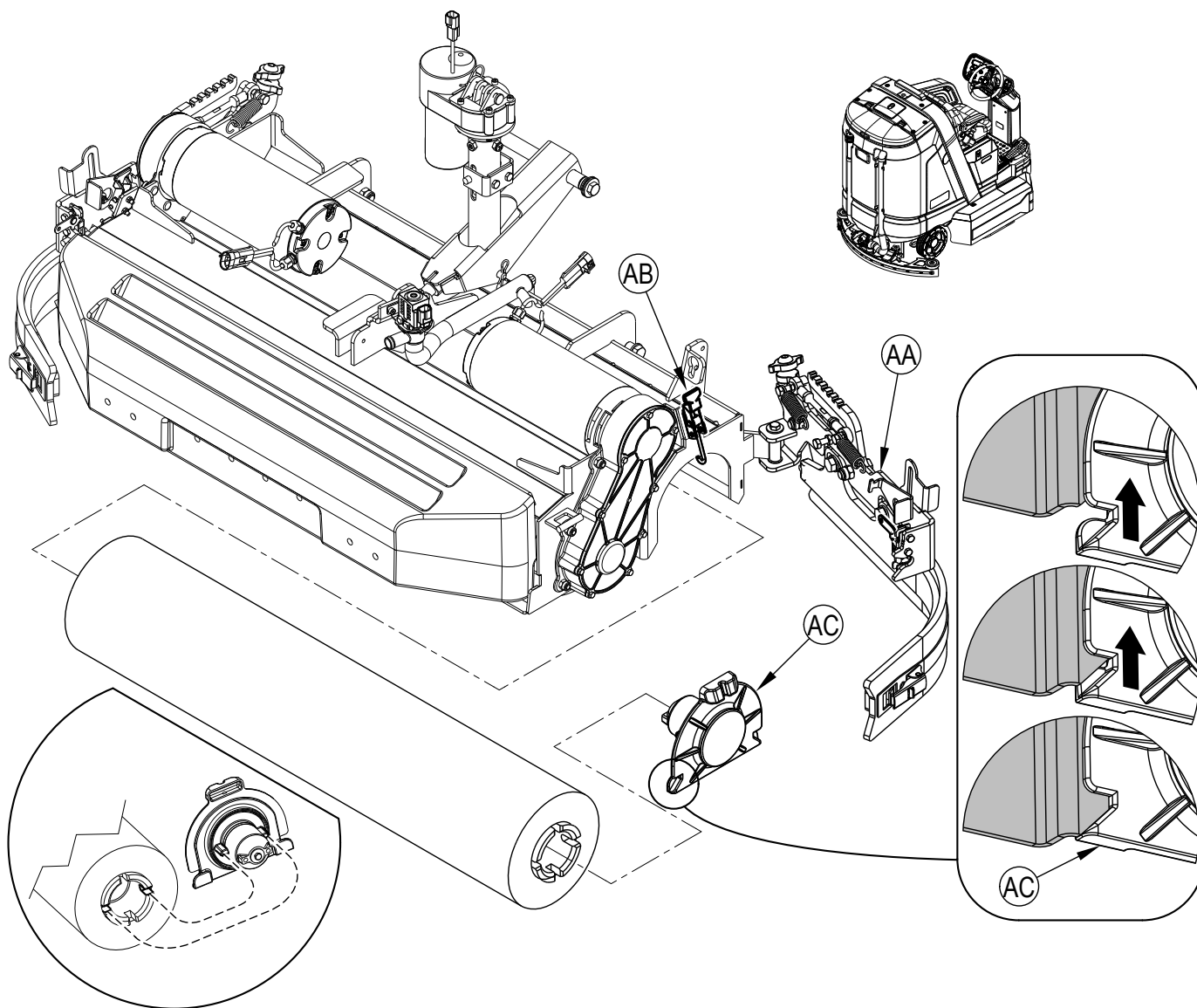

FILLING THE SOLUTION TANK

See **Figure 4**. Fill the solution tank with a maximum of 50 gallons (190 Liters) of cleaning solution. Do not fill the solution tank above 5 cm (2 inches) from the bottom of the Solution Fill (32). The solution should be a mixture of water and the proper cleaning chemical for the job. Always follow the dilution instructions on the chemical container label. **NOTE:** EcoFlex machines can either be used conventionally with detergent mixed in the tank or the detergent dispensing system can be used. When using the detergent dispensing do not mix detergent in the tank, plain water should be used.

⚠ CAUTION!

Use only low-foaming, non-flammable liquid detergents intended for machine application. Water temperature should not exceed 130 degrees Fahrenheit (54.4 degrees Celsius)

FIGURE 4

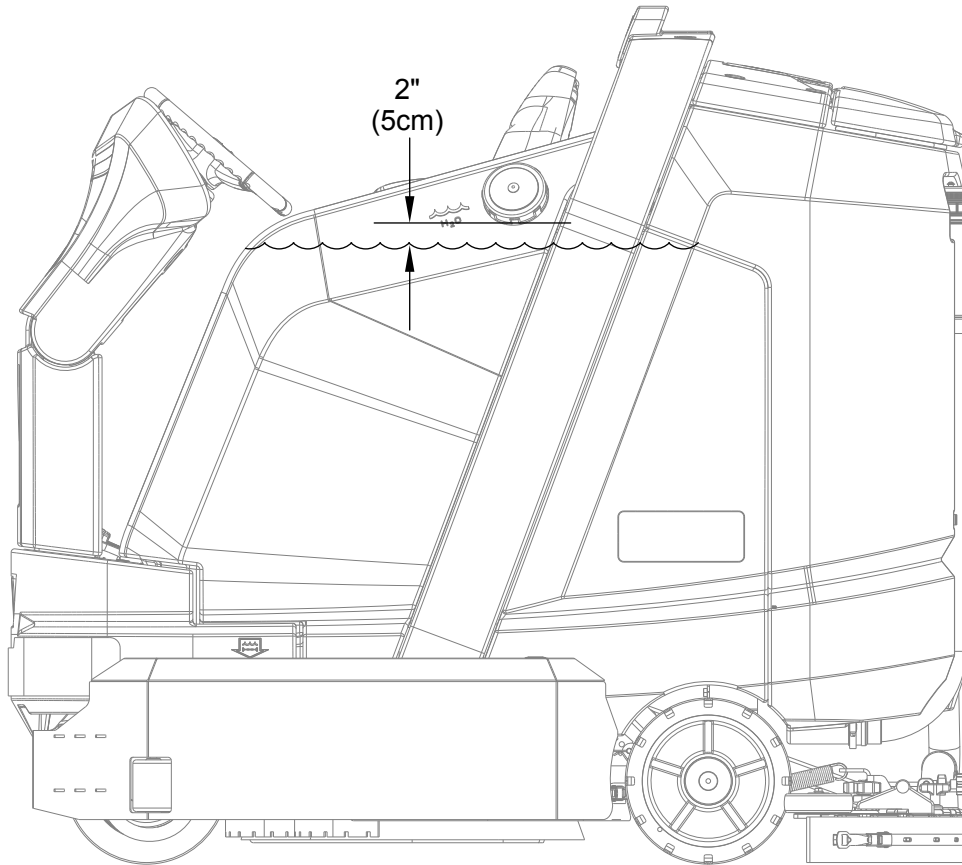

SOLUTION TANK INDICATOR

See **Figure 5**. The solution tank has a level sensor with four measurement points. The Solution Level Indicator (C4) displays the level (1-4) of the solution in the tank. Once the tank is empty the Solution Empty Indicator (C26) will flash on the display.

FIGURE 5

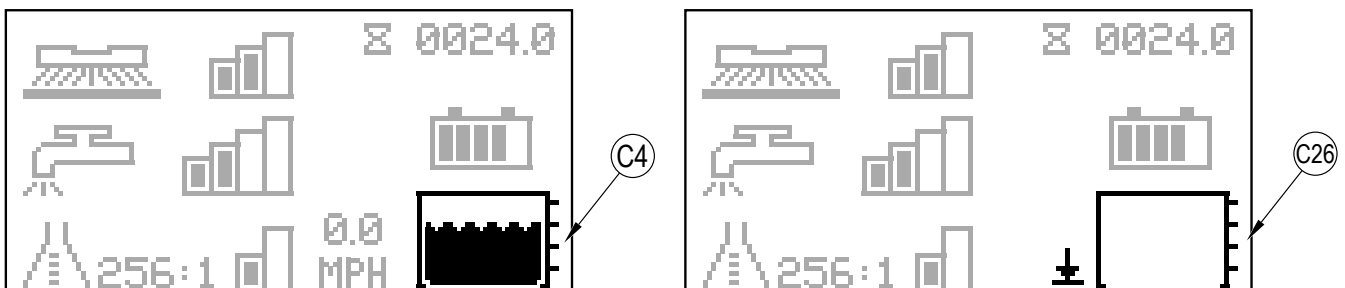

SQUEEGEE INSTALLATION

- 1 See **Figure 6**. Ensure the Squeegee Seal (**AA**) is free from debris and installed on the Squeegee Assembly (**24**). Lift the squeegee assembly by its Handles (**AB**) and slide it onto the Squeegee Mount (**AC**) and tighten the Squeegee Mount Thumb Nuts (**21**).
- 2 Connect the Recovery Hose (**33**) to the squeegee mount (**AC**).
- 3 Lower the squeegee and move the machine ahead slightly. Check that the rear squeegee blade touches the floor evenly across its entire width and is bent over slightly as shown in the squeegee cross section (**AD**). If necessary adjust the rear squeegee to the proper height and angle by following the steps in the "Squeegee Adjustment" section.

FIGURE 6

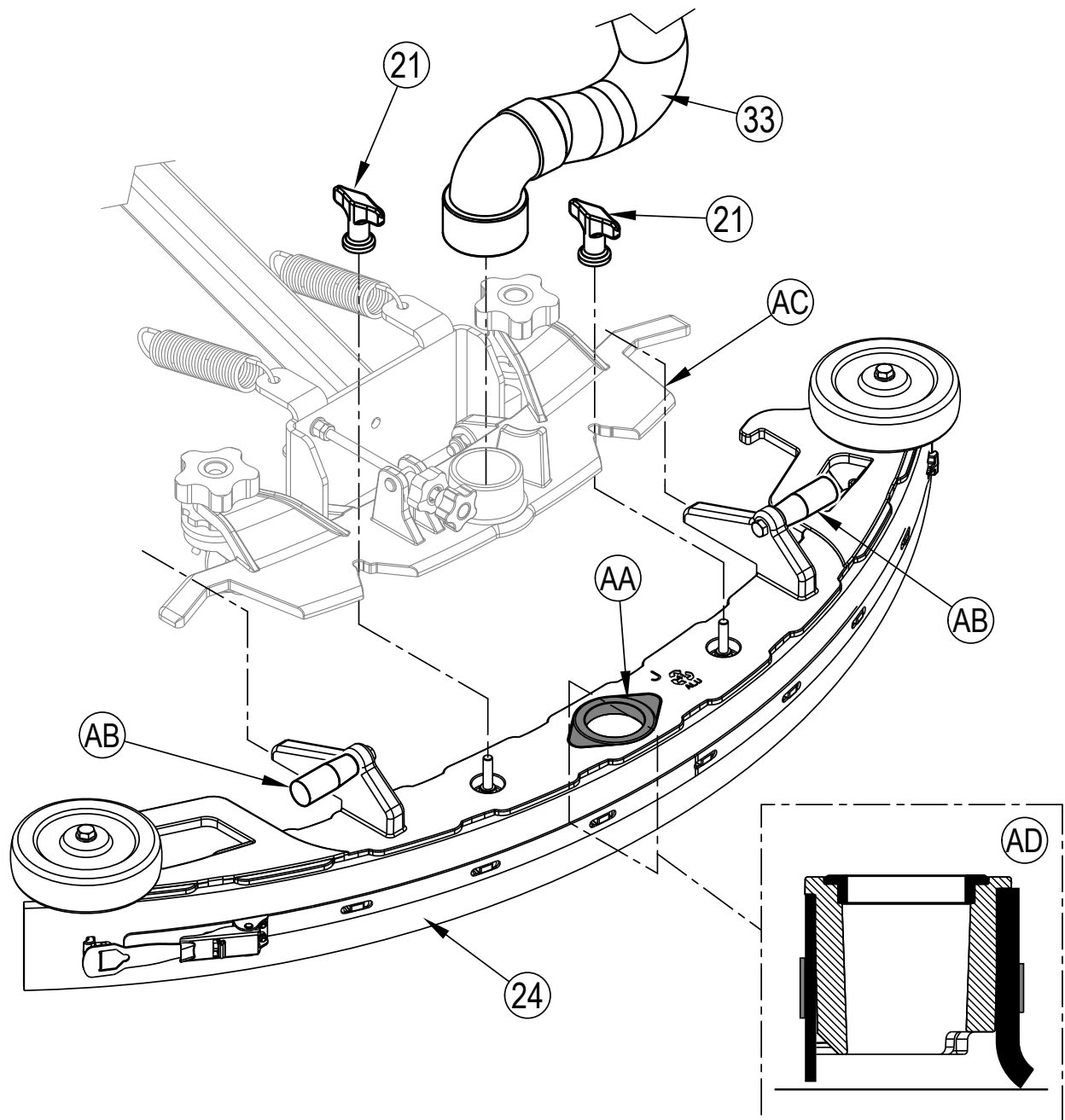

DETERGENT SYSTEM PREPARATION AND USE (ECOFLEX MODELS ONLY)

The Detergent Cartridge (8) is located beneath the seat. Fill the detergent cartridge with a maximum of 1 gallon (4 Liters) of detergent. **SERVICE NOTE:** Remove the detergent cartridge from the machine prior to filling to avoid spilling detergent on the machine.

It is recommended that a separate cartridge be used for each detergent you plan to use. The detergent cartridges have a white decal on them so you can write the detergent name on each cartridge to avoid mixing them up. When installing a new cartridge, remove the factory cap and place the cartridge in the machine. Install the Dry Break Cap (AA) as shown in Figure 7.

The system should be purged of previous detergent when switching to a different detergent. **SERVICE NOTE:** Move machine over floor drain before purging because a small amount of detergent will be dispensed in the process.

To Purge When Changing Detergents (SCRUB AND SOLUTION SYSTEMS MUST BE OFF):

- 1 Disconnect and remove the detergent cartridge.
- 2 Place the Magnetic Smart Key (W) onto Smart Key Reader (A). Turn the Power Switch (B) ON. Wait a few seconds for the start-up sequence to finish.
- 3 Press and hold the Solution Switch (H) and the Detergent Switch (Q) down for 2 seconds. Release the switches when the Detergent Purge Indicator (C19) appears on the display (the Detergent Switch Light (Q1) and Solution Switch Light (H1) will be ON). **NOTE:** Once activated the purge process takes 20 seconds. Press (H) and (Q) again before 20 seconds to cancel purge. See illustration on next page for Detergent System indicators. Normally one purge cycle is adequate to purge the system.

To Purge Weekly (SCRUB AND SOLUTION SYSTEMS MUST BE OFF):

- 1 Disconnect and remove the detergent cartridge. Install and connect a Cartridge filled with clean water.
- 2 Follow steps 2 and 3 from "To Purge When Changing Detergent".

When the detergent level is nearing the bottom of the cartridge it is time to refill or replace the cartridge.

SERVICE NOTE: Follow the "To Purge Weekly" instructions above if the machine is going to be stored for an extended period of time.

Detergent Ratio (SCRUB SYSTEM MUST BE ON):

No detergent is dispensed until the scrub and detergent systems are enabled and the Drive Pedal (3) pushed forward.

- The Detergent Indicator (C6) will be displayed in scrub mode when the detergent system is installed on the machine.
- The Detergent Ratio Indicator (C7) will display the selected ratio when the detergent system is on.

There are 4 modes of EcoFlex operation:

- 1A. *Plain Water Cleaning Mode* - During scrubbing, the detergent system can be turned off at any time by pressing the Detergent Switch (Q) to allow scrubbing with water only. Detergent Ratio Indicator (C7) will be blank and Detergent Indicator Bar Graph (C8) will display no bars filled. Detergent Light (Q1) will be off.
- 2A. *Minimum Concentration Detergent Mode* - Activated by pressing the Detergent Switch (Q) when detergent is off (repeated presses will cycle to maximum Mode, off and back to minimum mode). Detergent Ratio Indicator (C7) will display the current minimum detergent level and Detergent Indicator Bar Graph (C8) will display first bar filled. Detergent Light (Q1) will be on. See below the steps "To program the Minimum Detergent Level".
- 3A. *Maximum Concentration Detergent Mode* - Activated by pressing the Detergent Switch (Q) when detergent is at minimum mode (repeated presses will cycle to minimum mode, off and back to maximum mode). Detergent Ratio Indicator (C7) will display the current maximum detergent level and Detergent Indicator Bar Graph (C8) will display left and right bars filled. Detergent Light (Q1) will be on. See below the steps "To program the Maximum Detergent Level". Do not use a concentration level exceeding the detergent manufacturer's recommendation.
- 4A. *Burst of Power Cleaning Mode* - Pull the Burst of Power Paddle (S) to increase the detergent ratio for one minute to the pre-programmed "maximum concentration" detergent level (as noted in programming instructions below). Detergent system will be turned ON at "minimum concentration" detergent level if it was off. This will also cause the solution flow rate to increase to the next level and the scrub pressure to increase to the next level. Burst of Power Indicator (C15) will blink for one minute on the display along with a 60 second timer countdown. Pull Paddle (S) again before 60 seconds to cancel Burst of Power. The amount of time Burst of Power runs is adjustable (see "Information Menu Display" submenu "Options").

To program the Maximum Concentration Detergent Level

1. Press the OneTouch™ Scrub switch (E) to activate the scrub system.
2. Press and release Detergent Switch (Q) until you have entered the maximum concentration detergent mode ((C8) shows left and right bars filled).
3. Press and hold the Detergent Switch (Q) for approximately 2 seconds until the Ratio Indicator (C7) flashes.
4. While the ratio is flashing, pressing and releasing the detergent switch will cycle through the available ratios (400:1, 300:1, 256:1, 200:1, 150:1, 128:1, 100:1, 64:1, 50:1, 32:1).
5. Once the desired ratio is displayed on the screen, stop and it will save the setting after 3 seconds.
6. Whenever the maximum concentration detergent setting is set to a lower concentration than the current minimum programmed concentration setting, the minimum concentration default setting will be equal to the maximum concentration setting until changed by the operator.

To program the Minimum Concentration Detergent Level

1. Press the OneTouch™ Scrub switch (E) to activate the scrub system.
2. Press and release Detergent Switch (Q) until you have entered the minimum concentration detergent mode ((C8) shows left bar filled).
3. Press and hold the Detergent Switch (Q) for approximately 2 seconds until the Ratio Indicator (C7) flashes.
4. While the ratio is flashing, pressing and releasing the detergent switch will cycle through the available ratios (Note: only ratios that are a lower concentration or equal to the maximum detergent setting will be available).
5. Once the desired ratio is displayed on the screen, stop and it will save the setting after 3 seconds.

Once set, the detergent flow rate automatically increases and decreases with the solution flow rate, but the detergent ratio remains the same.

DETERGENT SYSTEM PREPARATION AND USE (ECOFLEX MODELS ONLY)

FIGURE 7

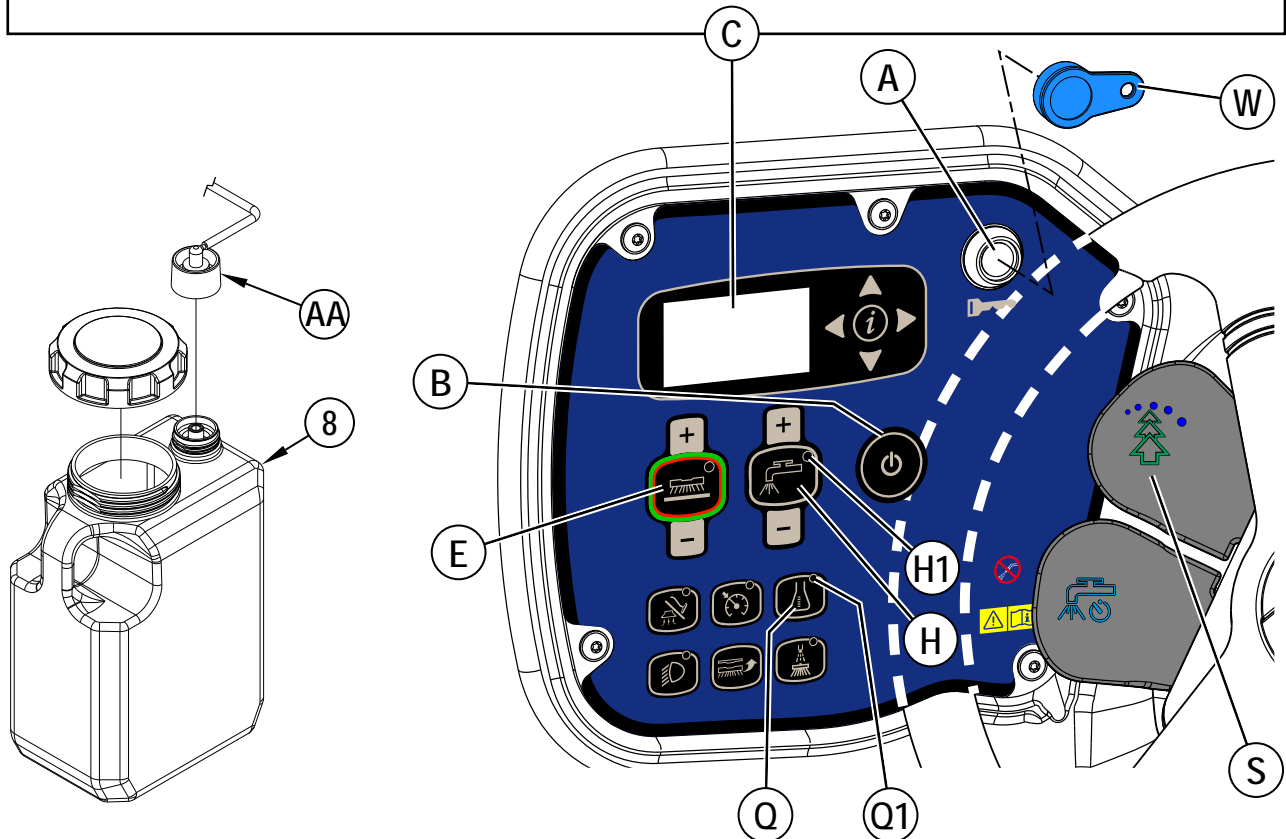
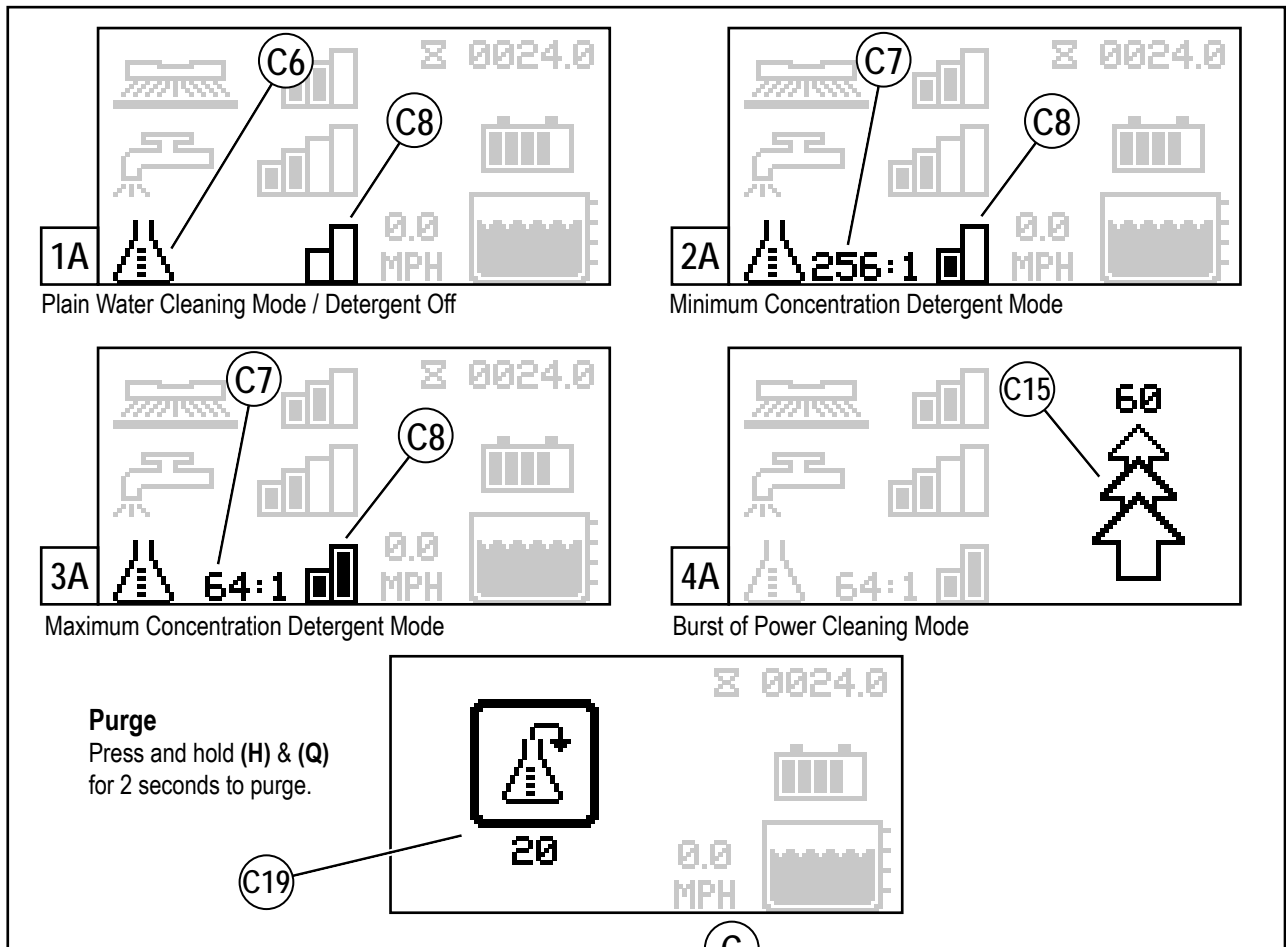

OPERATING THE MACHINE

WARNING!

Be sure you understand the operator controls and their functions.

While on ramps or inclines, avoid sudden stops when loaded. Avoid abrupt sharp turns. Use low speed down hills.

To Scrub...

Follow the instructions in "preparing the machine for use" section of this manual.

- 1 **See Figure 8.** While seated on the machine, adjust the seat and steering wheel to a comfortable operating position using the adjustment controls found on the seat and Steering column Tilt Adjust (16).
- 2 Place the Magnetic Smart Key (W) onto the Smart Key Reader (A). Press the Power Switch (B). This will activate the Display (C). Reference the Battery Condition Indicator (C3) and Hour Meter (C1) before proceeding.
- 3 To transport the machine to the work area, apply even pressure with your foot on the front of the Drive Pedal (3) to go forward or the rear of the pedal for reverse. Vary the pressure on the foot pedal to obtain the desired speed.
- 4 Press the Solution Switch (H) and hold for 5 seconds to pre-wet the floor. **NOTE:** This will help prevent scarring of the floor surface when starting to scrub with dry brushes. This must be done prior to pressing the One-Touch Scrub Switch (E).
- 5 Press the One-Touch Scrub ON Switch (E) once for Regular Scrub. Press the Scrub Pressure Increase Switch (F) once for Heavy Scrub or twice for Extreme Scrub mode. The solution flow has settings that coincide with the scrub pressure, it will increase and decrease along with the scrub pressure.
NOTE: The solution flow rate can also be increased or decreased independently of the scrub pressure by pressing the Solution Flow Increase Switch (J) or Solution Flow Decrease Switch (K), observe the Solution Flow Rate Bar Graph (C10) (see Control Panel). Any subsequent scrub pressure adjustments will reset the solution flow rate to default.
- 6 When the One-Touch Scrub ON Switch (E) is selected, the brushes and squeegee are automatically lowered to the floor. The scrub, solution, vacuum and detergent (EcoFlex models) systems are all automatically enabled and will start when the Drive Pedal (3) is activated. Any individual system can be turned OFF or back ON by simply pressing its switch at any time during scrubbing.
NOTE: When operating the machine in reverse the squeegee automatically raises.
- 7 Begin scrubbing by driving the machine forward in a straight line at a normal walking speed and overlap each path by 2-3 inches (50-75 mm). Adjust the machine speed and solution flow when necessary according to the condition of the floor. Pull the Timed Solution Off Paddle (R) before entering a turn to temporarily turn off the solution flow. The Solution Flow Rate Bar Graph (C10) will be replaced by a 5 second countdown timer showing how long the solution flow will be off. Pull paddle again before timer runs out to cancel solution off.
NOTE: While scrubbing the maximum machine speed can be set by pressing the Speed Limiter Switch (N). Adjust the machine to the desired speed using the Drive Pedal (3) then press the Speed Limiter Switch (N). The operator can now press the pedal all the way forward without increasing the machine speed thereby reducing operator fatigue. The machine Speed (C5) is shown on the display.

CAUTION!

To avoid damaging the floor, keep the machine moving while the brushes are turning.

- 8 When scrubbing, check behind the machine occasionally to see that all of the waste water is being picked up. If there is water trailing the machine, you may be dispensing too much solution, the recovery tank may be full, or the squeegee tool may require adjustment.
- 9 The machine defaults to the last cleaning mode used Minimum or Maximum Concentration Detergent (if detergent is installed and was activated). Pull the Burst of Power Paddle (S) to override the current cleaning mode and temporarily increase scrub pressure, solution flow and the detergent ratio (unless in Maximum Concentration). This will cause the Burst of Power Indicator (C15) to be displayed along with a countdown timer for one minute, solution flow rate will increase to the next level, scrub pressure will increase to the next level and the detergent ratio will be at the Maximum Concentration level (detergent system will be turned on at Minimum Concentration level if it was off).
NOTE: Repeatedly pressing and releasing the Detergent Switch (Q) will cycle between Minimum Concentration, Maximum Concentration and detergent off. The EcoFlex system will only function if the scrub system (E) has been enabled.
- 10 For extremely dirty floors, a one-pass scrubbing operation may not be satisfactory and a "double-scrub" operation may be required. This operation is the same as a one-pass scrubbing except on the first pass the squeegee and scrub deck blades are in the up position (press the Vacuum/Wand Switch (L) to raise the squeegee). Open both scrub deck Side Doors (15) and step down on the side blade Raise/Lower Lever (AA) to raise the side blades. This allows the cleaning solution to remain on the floor to work longer. The final pass is made over the same area, with the squeegee and side blades (step down on Lever (AA) again to lower) lowered to pick up the accumulated solution.
- 11 The recovery tank has a Tank Full Switch (19) that causes ALL systems to turn OFF except the drive system when the recovery tank is full. When this switch is activated, the recovery tank must be emptied. The machine will not pick up water or scrub with the switch activated.
NOTE: Scrub, solution and detergent indicators vanish and the Recovery Tank Full Indicator (C13) appears on the Display Panel when the switch is activated.
- 12 When the operator wants to stop scrubbing or the recovery tank is full, press the One-Touch Scrub Switch (E) once. This will automatically stop the scrub brushes and solution flow and the scrub deck will raise up. The squeegee will raise up after a brief delay and the vacuum will stop after an additional delay (this is to allow any remaining water to be picked up without turning the vacuum back on).
- 13 Drive the machine to a designated waste water "DISPOSAL SITE" and empty the recovery tank. To empty, pull the Drain Hose (20) from its rear storage area, then remove the plug (hold the end of the hose above the water level in the tank to avoid sudden, uncontrolled flow of waste water). Refill the solution tank and continue scrubbing.

NOTE: Make sure the Recovery Tank Cover (1) and the Recovery Tank Drain Hose (20) cap are properly seated or the machine will not pick-up water correctly.

When the batteries require recharging the Battery Low Voltage Indicator (C14) will come on, the scrub brushes and solution flow will stop and the scrub deck will raise up. The squeegee will raise up after a brief delay and the vacuum will stop after an additional delay. Transport the machine to a service area and recharge the batteries according to the instructions in the Battery section of this manual.

WET VACUUMING

Steps to follow in fitting the machine with optional attachments for wet vacuuming.

- 1 Disconnect the recovery hose (33) from the squeegee mount. Connect the coupler and hose from the wand kit to the recovery hose.
- 2 Attach suitable wet pick-up tools to the hose. (An optional Vac Wand Kit PN56116355 is available from Advance).
- 3 Place the magnetic key onto the Smart Key Reader (A) and press the Power Switch (B). While standing alongside the machine (not on the seat) press the Vacuum/Wand Switch (L). The vacuum motor and the pump will run continuously until the switch is pressed again to turn it OFF. The Wand Indicator (C17) is displayed. **NOTE:** Pressing the Vacuum/Wand Switch (L) while seated on the machine will cause the squeegee to lower and the vacuum motor(s) to run while machine is moving forward. The Vacuum Indicator (C16) will be displayed.

SERVICE NOTE: Refer to the service manual for detailed functional descriptions of all controls and optional programmability.

FIGURE 8

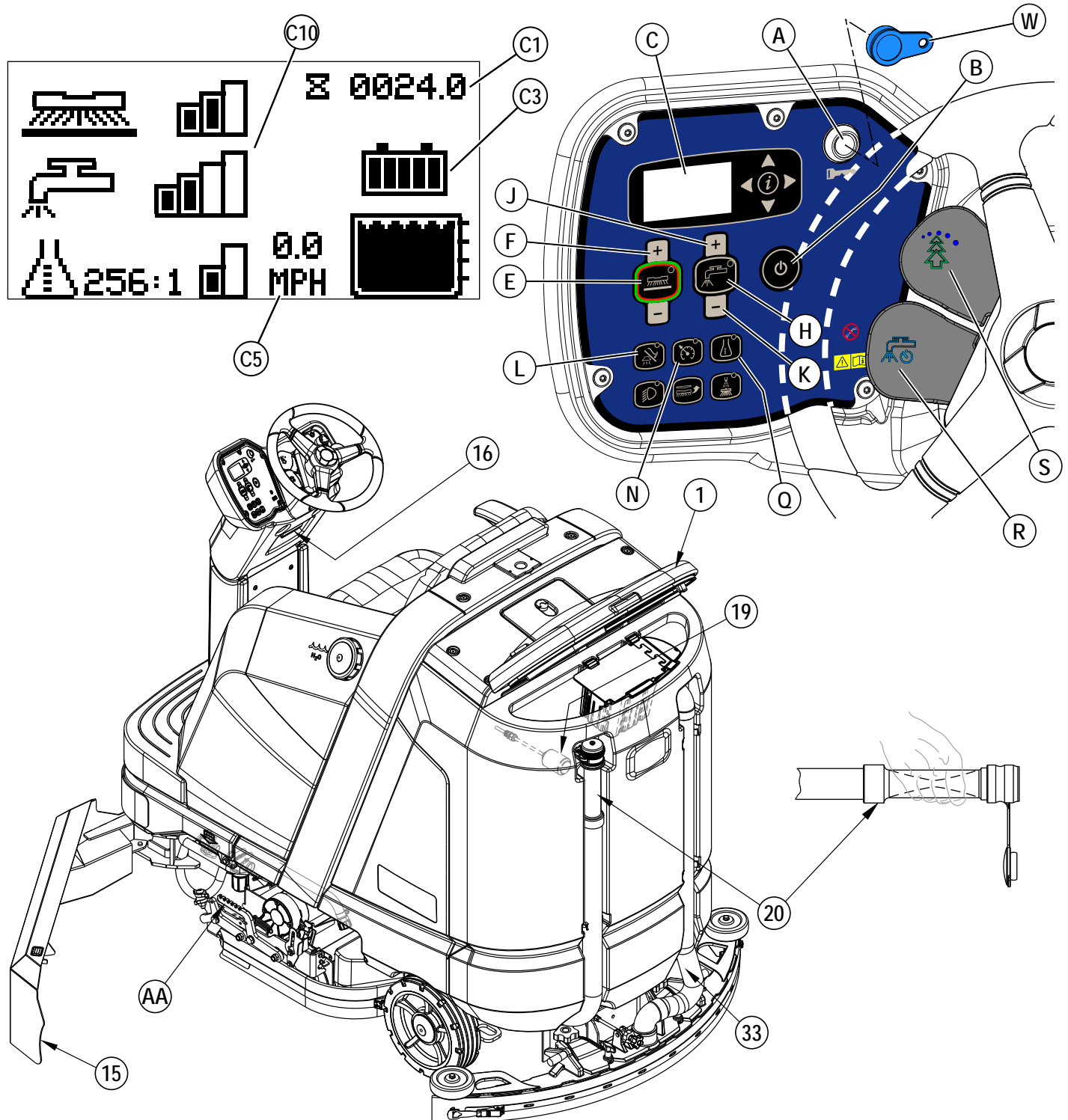

AFTER USE

- 1 When finished scrubbing, press the One-Touch Scrub Switch **(E)**. This will automatically raise, retract and stop all the machine systems (brush, squeegee, vacuum, solution and detergent (EcoFlex models)). Then drive the machine to a service area for daily maintenance and review of other needed service up keep.
- 2 To empty the solution tank, open the left side scrub deck door and remove the Solution Drain Hose **(31)** from its storage clamp. Direct the hose to a designated "DISPOSAL SITE" and remove the plug. Rinse the tank with clean water.
- 3 To empty the recovery tank, pull the Recovery Tank Drain Hose **(20)** from its storage area. Direct the hose to a designated "DISPOSAL SITE" and remove the plug (hold the end of the hose above the water level in the tank to avoid sudden, uncontrolled flow of waste water). The Recovery Tank Drain Hose can be squeezed to regulate the flow. Rinse the recovery tank with clean water. Inspect the recovery and vacuum hoses; replace if kinked or damaged.
- 4 Remove the brushes or pad holders. Rinse the brushes or pads in warm water and hang up to dry.
- 5 Remove the squeegee, rinse it with warm water and re-install on mount or hang it from the back of the recovery tank.
- 6 Remove the hopper on cylindrical systems and clean thoroughly. Remove from either side of the machine by opening the scrub deck door, unlatching and swinging open the side blade and tilting the hopper up and away from housing, then pull out.
- 7 Check the maintenance schedule below and perform any required maintenance before storage.
- 8 Store the machine indoors in a clean dry place. Keep from freezing. Leave the tanks open to air them out.
- 9 Turn the machine off by pressing the Power Switch **(B)** and then remove the magnetic key.
- 10 Batteries are the most expensive replacement item on this machine. To protect your investment and to get as many cycles from the batteries as possible, remember the following:
 - Batteries will last longer if kept fully charged.
 - Batteries equipped with this machine will not develop a memory.
 - Batteries will last longer and will deliver more cycles if they are opportunity charged.
 - Battery chargers will not over or undercharge the batteries.
 - Batteries will prematurely fail if stored in a discharged state.
 - Every day after use, the battery charger must be plugged in and the charger must be allowed to run through a full charging sequence to fully charge the batteries.

MAINTENANCE SCHEDULE

MAINTENANCE ITEM	Daily	Weekly	Monthly	Yearly
Charge Batteries	X			
Check/Clean Tanks & Hoses	X			
Check/Clean/Rotate the Brushes/Pads	X			
Check/Clean the Squeegee	X			
Empty/Clean Debris Catch Tray in Recovery Tank	X			
Check/Clean the vacuum motor foam filter(s)	X			
Clean Hopper on Cylindrical System	X			
Check Each Battery Cell(s) Water Level		X		
Inspect Scrub Housing Blades		X		
Inspect and clean Solution Filter		X		
Clean Solution Trough on Cylindrical System		X		
Purge Detergent System (EcoFlex only)		X		
Lubrication – see "Lubricating the Machine"			X	
* Check Carbon Brushes				X

* Have Advance check the vacuum motor carbon motor brushes after 1200 recovery hours (replace motor after 2000 recovery hours).

NOTE: Refer to the Service Manual for more detail on maintenance and service repairs.

LUBRICATING THE MACHINE

Once a month, pump a small amount of grease into each grease fitting on the machine until grease seeps out around the bearings. See Figure 10.

Grease fitting locations (or apply grease to) (AA):

- Squeegee Caster Wheel Axle and Pivot
- Steering Wheel Shaft Universal joint
- Steering Chain
- Squeegee mount angle adjustment knob threads

Once a month, apply light machine oil or synthetic lubricant spray to lubricate (AB):

- Side Blade Down Stop Adjustment Threads

FIGURE 10

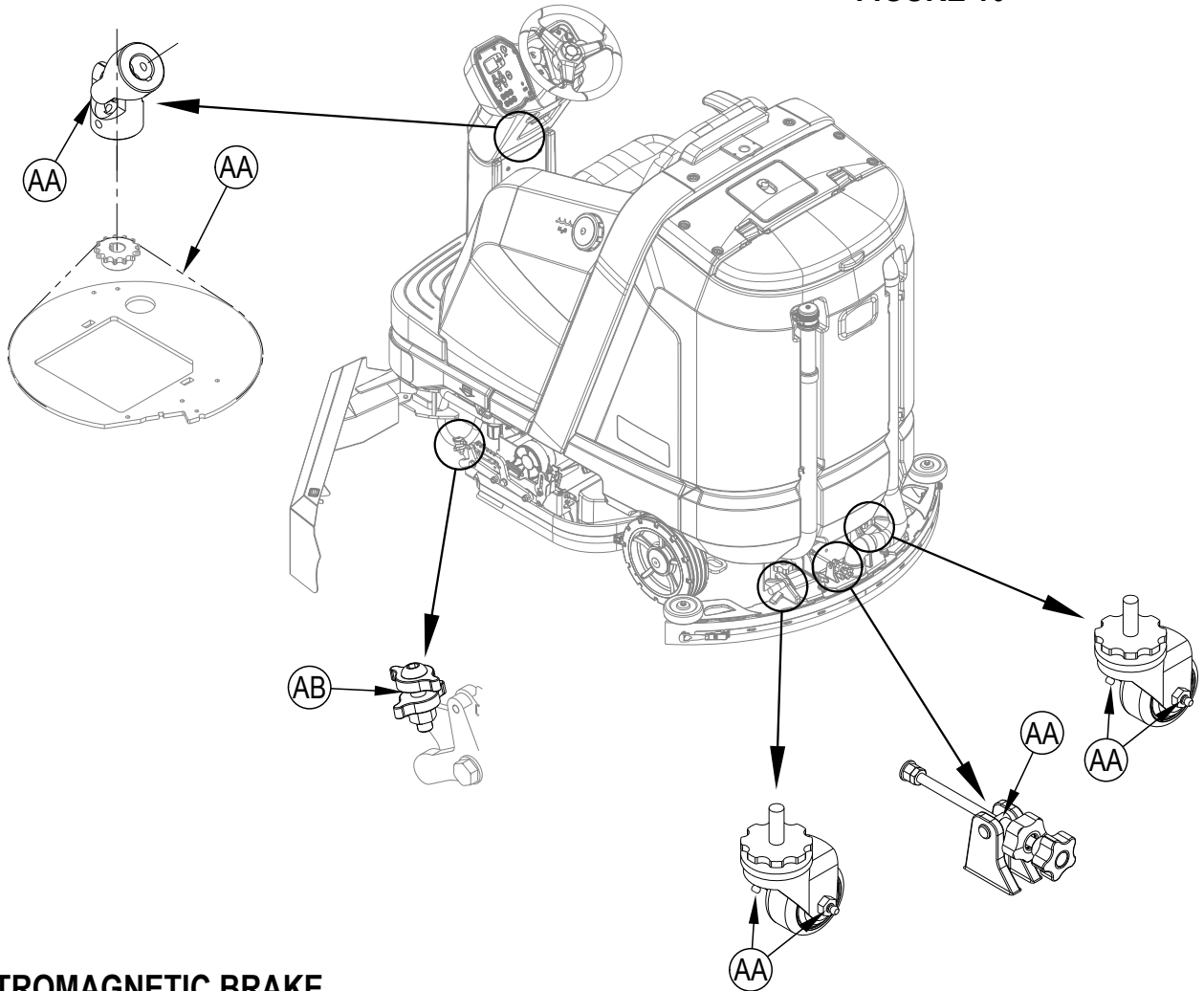

ELECTROMAGNETIC BRAKE

⚠ CAUTION!

To avoid uncontrolled machine movement, block the wheels and ensure machine is on a level surface before disengaging the electromagnetic brake.

See Figure 11. The Drive Wheel Assembly (4) has a built in electromagnetic brake that is engaged whenever the machine power is OFF or the Drive Pedal (3) is not being pressed, machine in neutral. This brake can be manually overridden if necessary by inserting a medium to large screwdriver behind the Yoke (AC) as shown. This should only be done in the event you need to push or pull the unit.

FIGURE 11

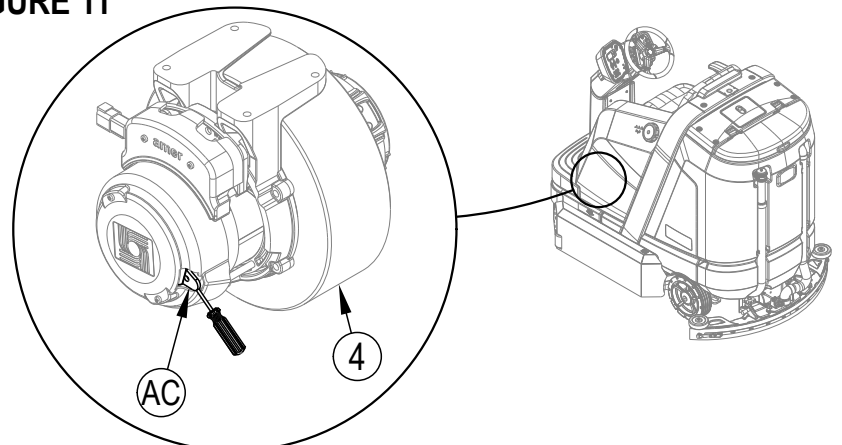

CHARGING WET BATTERIES

Charge the batteries each time the machine is used or when the Battery Charge Level Indicator (C3) is reading less than full.

⚠ WARNING!

Do not top off the batteries before charging. Check to ensure the plates are covered only.

Charge batteries in a well-ventilated area. If battery acid makes contact with your skin, flush the affected area with water for 5 minutes and seek medical attention.

Do not smoke while servicing the batteries.

When Servicing Batteries...

- * Remove all jewelry
- * Do not smoke
- * Wear safety glasses, rubber gloves and a rubber apron
- * Work in a well-ventilated area
- * Do not allow tools to touch more than one battery terminal at a time
- * ALWAYS disconnect the negative (ground) cable first when replacing batteries to prevent sparks.
- * ALWAYS connect the negative cable last when installing batteries.

If your machine shipped with an onboard battery charger do the following:

- 1 Turn the machine off at the Power Switch (B).
- 2 **See Figure 12.** Raise the steering column to the full upright position. Tip the seat forward and engage the Seat Prop Rod (9) for battery, charger access and proper ventilation.
- 3 Unwind the electrical cord for the onboard charger and plug it into a properly grounded outlet. Refer to the OEM product manual for more detailed operating instructions. While AC power is applied to the onboard charger all machine functions are disabled.
- 4 The Battery Charge Status Indicator (C19) will begin showing the batteries' state of charge. This indicates that the charging cycle has begun. As the charging cycle continues, the battery charge level will fill in.
- 5 When the Battery Charge Status Indicator (C19) is completely filled, the machine senses fully charged batteries, however the charging process may not be complete. Rely on the status lights on the Charger (12) (and its OEM manual) to verify when the batteries are completely charged. This may take several hours depending upon the condition of the batteries before charging.
- 6 After charging is complete unplug the charger and wind up the Cord (12A). Wait at least 10 seconds before turning on the machine after unplugging the charger.

If your machine shipped without an onboard battery charger do the following:

- 1 Turn the machine off at the Power Switch (B).
- 2 **See Figure 12.** Raise the steering column to the full upright position. Tip the seat forward and engage the Seat Prop Rod (9) for battery access and proper ventilation.
- 3 Disconnect the batteries from the machine and push the connector from the charger into the Machine Battery Connector (10). Follow the instructions on the battery charger. **SERVICE NOTE:** Make sure you plug the battery charger into the connector that attaches to the batteries.

⚠ CAUTION!

To avoid damage to floor surfaces, wipe water and acid from the top of the batteries after charging. Under or overcharging will shorten battery life and limit performance. Be sure to FOLLOW PROPER CHARGING INSTRUCTIONS!

CHECKING THE BATTERY WATER LEVEL

Check the water level of the batteries at least once a week.

Remove the vent caps and check the water level in each battery cell. Use distilled or demineralized water in a battery filling dispenser (available at most auto parts stores) to fill each cell to the level indicator (or to .39 inches / 10 mm over the top of the separators). DO NOT over-fill the batteries!

⚠ CAUTION!

Acid can spill onto the floor if the batteries are overfilled.

Tighten the vent caps. Wash the tops of the batteries with a solution of baking soda and water (2 tablespoons of baking soda to 1 liter of water).

FIGURE 12

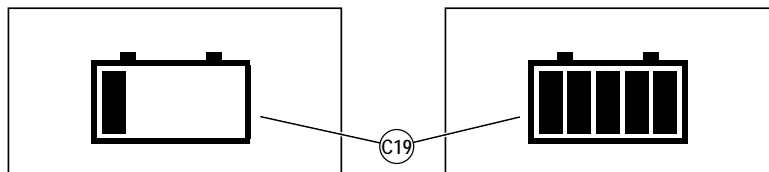
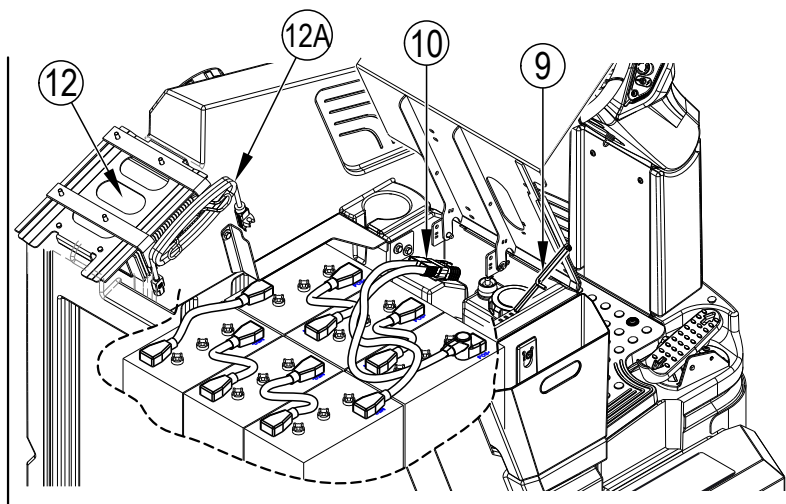

CHARGING GEL/AGM (VRLA) BATTERIES

Charge the batteries each time the machine is used or when the Battery Charge Level Indicator (C3) is reading less than full.

⚠ WARNING!

Charge batteries in a well-ventilated area. If battery acid makes contact with your skin, flush the affected area with water for 5 minutes and seek medical attention.

Do not smoke while servicing the batteries.

When Servicing Batteries...

- * Remove all jewelry
- * Do not smoke
- * Wear safety glasses, rubber gloves and a rubber apron
- * Work in a well-ventilated area
- * Do not allow tools to touch more than one battery terminal at a time
- * ALWAYS disconnect the negative (ground) cable first when replacing batteries to prevent sparks.
- * ALWAYS connect the negative cable last when installing batteries.

⚠ CAUTION!

Your valve regulated lead acid (VRLA) battery will deliver superior performance and life ONLY IF IT IS RECHARGED PROPERLY! Under or overcharging will shorten battery life and limit performance. Be sure to FOLLOW PROPER CHARGING INSTRUCTIONS! DO NOT ATTEMPT TO OPEN THIS BATTERY! If a VRLA battery is opened, it loses its pressure and the plates become oxygen contaminated. THE WARRANTY WILL BE VOIDED IF THE BATTERY IS OPENED.

FIGURE 12

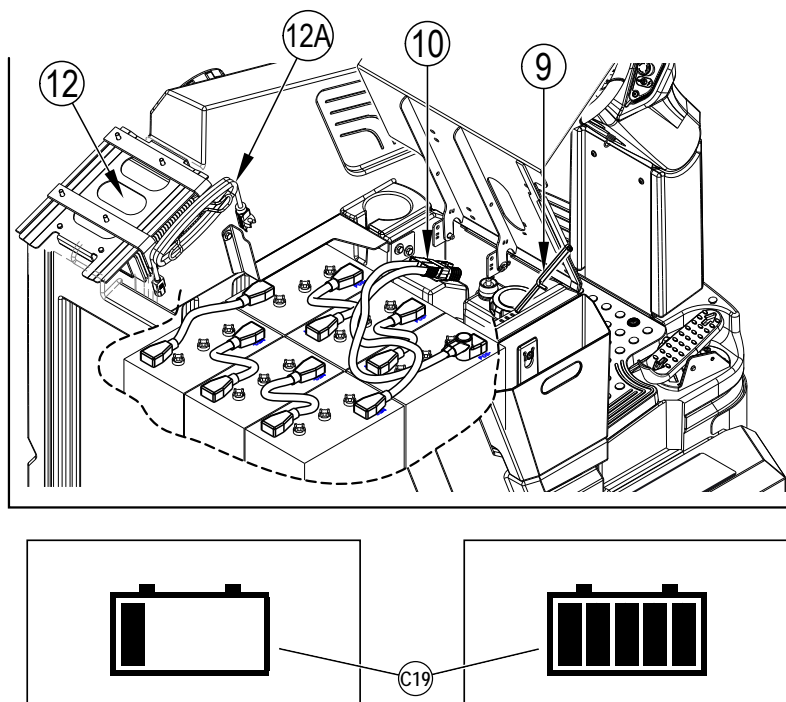

If your machine shipped with an onboard battery charger do the following:

- 1 Turn the machine off at the Power Switch (B).
- 2 **See Figure 12.** Raise the steering column to the full upright position. Tip the seat forward and engage the Seat Prop Rod (9) for battery, charger access and proper ventilation.
- 3 Unwind the electrical cord for the onboard charger and plug it into a properly grounded outlet. Refer to the OEM product manual for more detailed operating instructions. While AC power is applied to the onboard charger all machine functions are disabled.
- 4 The Battery Charge Status Indicator (C19) will begin showing the batteries' state of charge. This indicates that the charging cycle has begun. As the charging cycle continues, the battery charge level will fill in.
- 5 When the Battery Charge Status Indicator (C19) is completely filled, the machine senses fully charged batteries, however the charging process may not be complete. Rely on the status lights on the Charger (12) (and its OEM manual) to verify when the batteries are completely charged. This may take several hours depending upon the condition of the batteries before charging.
- 6 After charging is complete unplug the charger and wind up the Cord (12A). Wait at least 10 seconds before turning on the machine after unplugging the charger.

If your machine shipped without an onboard battery charger do the following:

- 1 Turn the machine off at the Power Switch (B).
- 2 **See Figure 12.** Raise the steering column to the full upright position. Tip the seat forward and engage the Seat Prop Rod (9) for battery access and proper ventilation.
- 3 Disconnect the batteries from the machine and push the connector from the charger into the Machine Battery Connector (10). Follow the instructions on the battery charger. **SERVICE NOTE:** Make sure you plug the battery charger into the connector that attaches to the batteries.

IMPORTANT: Make sure you have an appropriate charger for use on Gel cell batteries. Use only "voltage-regulated" or "voltage-limited" chargers. Standard constant current or taper current chargers MUST NOT be used. A temperature-sensing charger is recommended, as manual adjustments are never accurate and will damage any VRLA battery.

SQUEEGEE MAINTENANCE

If the squeegee leaves narrow streaks or water, the blades may be dirty or damaged. Remove the squeegee, rinse it under warm water and inspect the blades. Reverse or replace the blades if they are cut, torn, wavy or worn.

To Reverse or Replace the Rear Squeegee Wiping Blade...

- 1 **See Figure 13.** Raise the squeegee tool off the floor, then unsnap the Latch **(AA)** on the squeegee tool.
- 2 Remove the Tension Strap **(AB)**.
- 3 Slip the rear blade off the alignment pins.
- 4 The squeegee blade has 4 working edges as shown below. Turn the blade so a clean, undamaged edge faces toward the front of the machine. Replace the blade if all 4 edges are nicked, torn or worn to a large radius.
- 5 Install the blade, following the steps in reverse order and adjust the squeegee tilt.

To Reverse or Replace the Front Squeegee Blade...

- 1 Raise the squeegee tool off the floor, then loosen the (2) Thumb Nuts **(21)** on top of the squeegee and remove the squeegee tool from the mount.
- 2 Loosen the Front Squeegee Blade Removal Thumb Nut **(AC)**, then remove Tension Strap **(AD)** and front blade
- 3 The squeegee blade has 4 working edges as shown below. Turn the blade so a clean, undamaged edge faces toward the front of the machine. Replace the blade if all 4 edges are nicked, torn or worn to a large radius.
- 4 Install the blade, following the steps in reverse order and adjust the squeegee tilt.

SQUEEGEE ADJUSTMENT

There are two squeegee tool adjustments possible, angle and height.

Adjust the squeegee angle whenever a blade is reversed or replaced, or if the squeegee is not wiping the floor dry.

- 1 Park the machine on a flat, even surface.
- 2 Lower the squeegee, move the machine ahead slightly and adjust the squeegee tilt and height using the Squeegee Tilt Adjust Knob **(22)** and Squeegee Height Adjust Knobs **(23)** so that the rear squeegee blade touches the floor evenly across its entire width and is bent over slightly as shown in the squeegee cross section.
- 3 Squeegee height is pre-set at the factory but may require periodic adjustment due to caster wear. Proper squeegee height is achieved when the front squeegee blade is in contact with the floor but not bent over.
 - a. Loosen Height Adjust Knob **(23)**.
 - b. Thread Caster **(AE)** up or down as required to achieve proper height and ensure blade position is uniform left to right.
 - c. Tighten Caster Stop **(AF)** against squeegee mount **(AG)**.
 - d. Tighten Height Adjust Knob **(23)** against squeegee mount to lock adjustment.
- 4 The Tilt Adjust Knob **(22)** is used to adjust the tool angle for uniform contact from center to tips of blade.
 - a. Loosen Tilt Stop Knob **(AH)**.
 - b. Turn Tilt Adjust Knob as required to adjust.
 - c. Tighten Tilt Stop Knob **(AH)** against the squeegee mount to lock adjustment.

SQUEEGEE MAINTENANCE

FIGURE 13

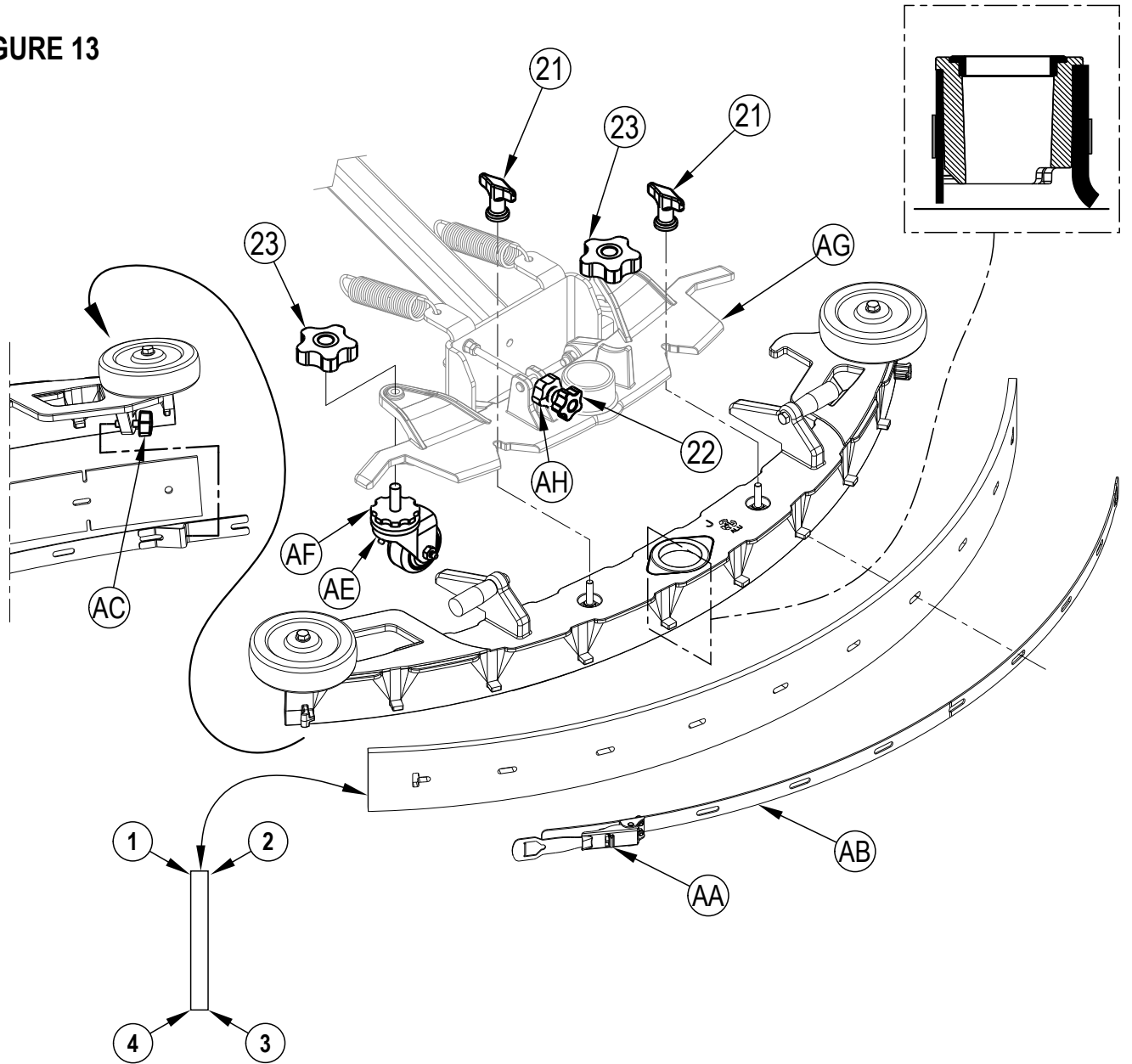

SIDE BLADE MAINTENANCE

The side blade's function is to channel the waste water to the squeegee, helping contain the water within the machines cleaning path. During normal use the blades will wear in time. The operator will notice a small amount of water leaking out underneath the side blades. A height adjustment can easily be made to lower the blades so that all the water can be picked-up by the squeegee.

To reverse or replace the scrub system side blades ...

- 1 Unlatch and open the scrub deck side doors **(15)**.
- 2 **See Figure 14-1.** Unlatch the retaining strap **(AA)** and remove the strap and blade.
- 3 The main side blade has 4 working edges as shown. Turn the blade so a clean, undamaged edge faces toward the center of the machine. Swap the right and left side blades to use the remaining two edges. Replace the blades as a set if all edges are nicked, torn or worn beyond their ability to be adjusted.
- 4 Reinstall the blade onto the blade assembly and secure by latching the retainer strap **(AA)**. Adjust the blade for proper contact to the floor when the brush deck is placed in the scrub position.

SIDE BLADE HEIGHT ADJUSTMENT

- 1 The down stop can be adjusted on the side blades to compensate for blade wear.
- 2 Make sure the machine is on a level surface.
- 3 Lower the scrub deck by pressing the One-Touch Scrub Switch **(E)** and drive the machine forward a short distance to ensure the blades fold over.
- 4 Open the scrub deck side doors **(15)** and observe blade fold over.
- 5 To adjust, loosen the Side Blade Lock Knob **(AB)**. Turn the Down Stop Knob **(AC)** (Up or Down) to where the blades just fold over enough when scrubbing that all the waste water is contained inside the deck. **NOTE:** Make small adjustments to obtain good blade wiping. Do not lower the blades too much to where they fold over excessively and cause unneeded blade wear. Tighten the Side Blade Lock Knob **(AB)** to lock the adjustment.

SIDE BLADE PRESSURE ADJUSTMENT

- 1 The scrub deck side blades have two settings for down pressure.
- 2 **See Figure 14-2.** Position 1 **(AE)** is normal wiping pressure, it is recommended to start at this setting. Position 2 **(AF)** is heavy wiping pressure, this setting can be used if wiping performance is not satisfactory. **NOTE:** Position 2 will cause faster blade wear.
- 3 Pull Bracket **(AG)** to change between the two settings. Use the same setting on both sides of the scrub deck.

DOUBLE SCRUB POSITION

- 1 **See Figure 14-3.** Step down on Blade Raise/Lower Lever **(AH)** to raise blade. **NOTE:** This position can also be used for installing/removing brushes.
- 2 When finished double scrubbing with the machine, step down again on Lever **(AH)** or pull Release Bracket **(AJ)** to lower side blade back to its normal operating position.

SIDE BLADE MAINTENANCE

FIGURE 14-1

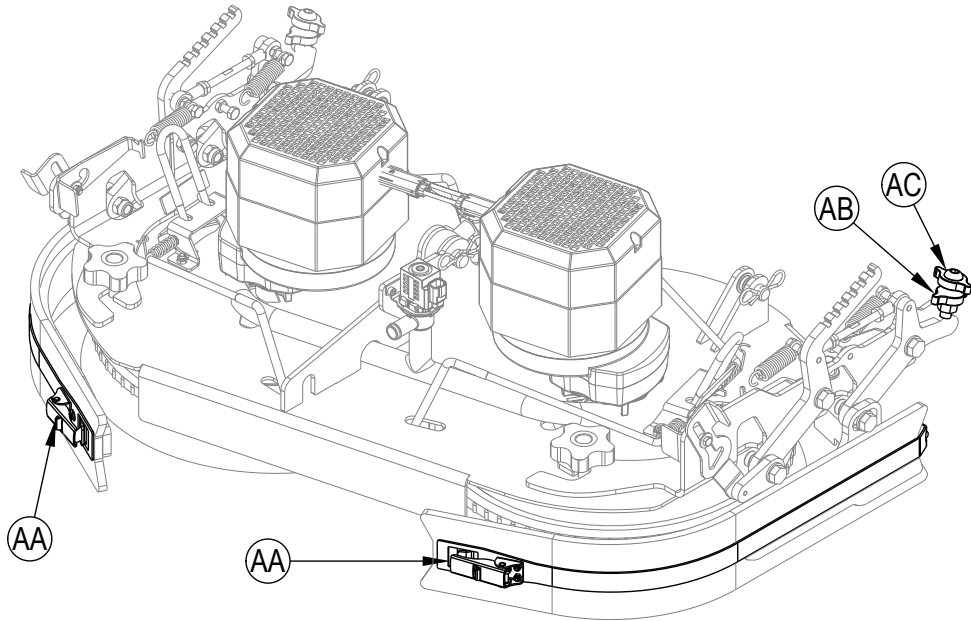

FIGURE 14-2

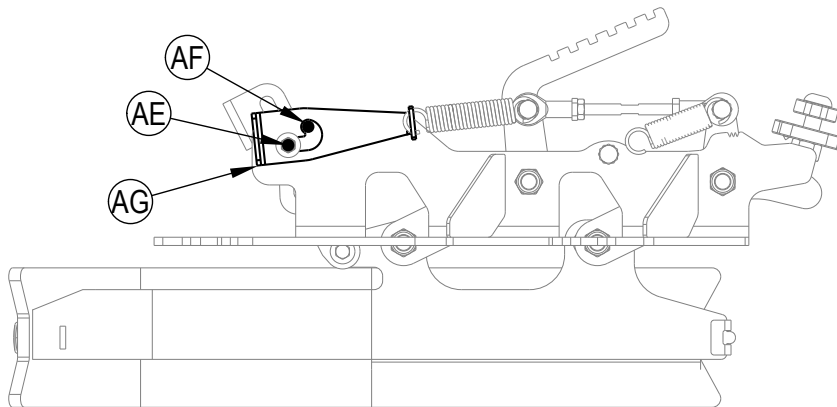
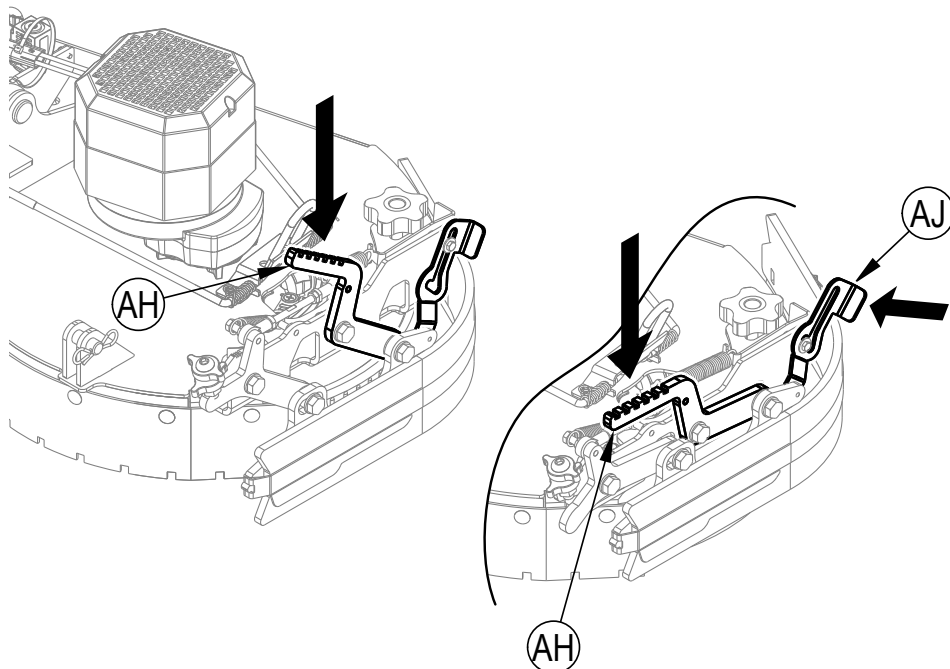

FIGURE 14-3



GENERAL MACHINE TROUBLESHOOTING

Problem	Possible Cause	Remedy
Poor water pick-up	Worn or torn squeegee blades	Reverse or replace
	Squeegee out of adjustment	Adjust so blades touch floor evenly across entire width
	Recovery tank full	Empty recovery tank
	Recovery tank drain hose leak	Secure drain hose cap or replace
	Recovery tank cover gasket leak	Replace gasket / Seat cover properly
	Debris caught in squeegee	Clean squeegee tool
	Squeegee seal clogged or missing	Clean or replace squeegee seal
	Vacuum hose clogged	Remove debris
	Using too much solution	Reduce flow via control panel solution button
	Foam filter cover not seated	Seat cover properly
Poor scrubbing performance	Worn brush or pad	Rotate or replace brushes
	Wrong brush or pad type	Consult Advance Authorized Service Center
	Wrong cleaning chemical	Consult Advance Authorized Service Center
	Moving machine too fast	Slow down
	Not using enough solution	Increase flow via control panel solution button
Inadequate solution flow or no solution	Solution tank empty	Fill solution tank
	Solution lines, valves, filter or trough clogged	Flush lines, trough and clean solution filter
	Solution turned OFF	Activate flow via control panel solution button
	Solution solenoid valve plugged or defective	Clean or replace valve (contact Advance Authorized Service Center)
Machine does not power ON	Machine Battery Connector (10) disconnected	Reset Emergency Stop Switch Reconnect battery connectors
	Tripped 10 Amp (CB1) circuit breaker (V)	Check for electrical short circuit & reset
	Blown Main Fuse 150 Amp (14)	Replace Main Fuse 150 Amp
No FWD/REV wheel drive	Drive system speed controller	Check error fault codes (contact Advance Authorized Service Center)
	Emergency Stop Switch (U) activated, display will show Emergency Stop Activated Indicator (C20) .	Reset Emergency Stop Switch
Poor Sweeping Performance (Cylindrical System)	Hopper Full	Empty and clean hopper
	Brushes worn	Replace brushes
	Bristles have taken a set	Rotate brushes
No Detergent Flow (EcoFlex models only)	Empty detergent cartridge	Fill detergent cartridge
	Plugged or kinked detergent flow line	Purge system, straighten lines to remove any kinks
	Dry seal cap on detergent cartridge not sealed	Reseat dry seal cap
	Detergent pump	Check pump, wiring and lines
Magnetic Smart Key Errors	No Key Indicator (C21) . -No Magnetic Smart Key is present on the Smart Key Reader (A) .	Place an appropriate Smart Key onto the Smart Key Reader.
	Key Read Error Indicator (C22) . - Magnetic Smart Key present on the Smart Key Reader (A) cannot be read.	Clean both the Smart Key and the Smart Key Reader using a clean cloth. Depress the Smart Key between your thumb and forefinger to insure free movement of the magnet.
	Restricted User Key Indicator (C23) . -Magnetic Smart Key present on the Smart Key Reader (A) is not programmed to be used with this machine.	Place a Smart Key that has been programmed to be used with this machine onto the Smart Key Reader.

GENERAL MACHINE TROUBLESHOOTING

FAULT CODE DISPLAY

Any fault codes detected by the controllers will be displayed on the control panel display as they occur. If more than one error exists, the display will sequence through the error codes at one-second intervals. The error will display as a mechanical wrench symbol  followed by a four-digit code. Fault codes are displayed as X-YYY, where X = system number (1: main board, 2: power module, 3: drive controller)

YYY = fault code number

For example,  1-101 would be solution solenoid valve – short.

C2 Active Fault Code

C24 Critical Fault Indicator

C25 Fault Code (Critical)

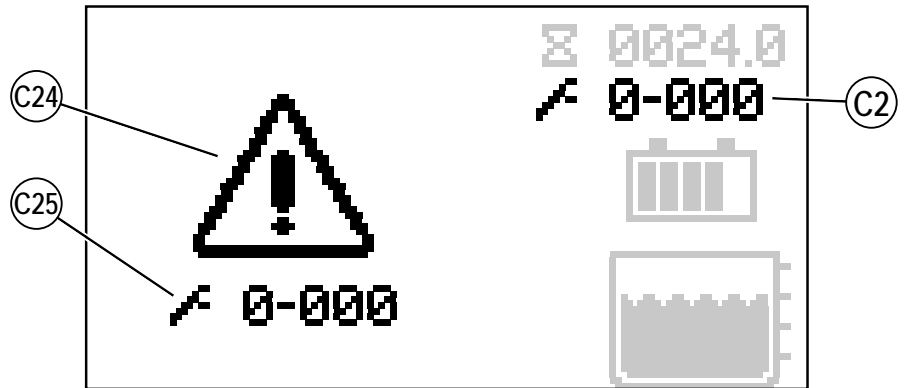

Fault Code	Description
E2 Main Controller Faults	
1-001	K1 Coil Open
1-002	K1 Coil Short
1-003	K1 Contact Weld
1-010	CAN Bus 0
1-011	CAN Bus 1
1-101	L1 Short
1-102	L2 Short
1-103	H2 Short
1-104	LP1,2 Short
1-105	H1 Short
1-106	M8 Short
1-107	M9 Short
1-201	Level Sensor
1-560	EEPROM Configuration
1-561	EEPROM Options
1-562	EEPROM Sys Values
1-563	EEPROM Fault Log
1-564	EEPROM User Key List
1-565	EEPROM Impact Log

Fault Code	Description
E3 Power Module Faults	
2-001	E3 Timeout
2-011	Precharge Fail
2-012	K2 Overload
2-013	K2 Contact Weld
2-014	K2 Contact Open
2-017	OverVolt Cutoff
2-018	UnderVolt Cutoff
2-021	M1 Open
2-022	M2 Open
2-023	M3 Open
2-024	M4 Open
2-025	M5 Open
2-026	M6 Open
2-027	M7 Open
2-028	M10 Open
2-031	M1 Overload
2-032	M2 Overload
2-033	M3 Overload
2-034	M4 Overload
2-035	M5 Overload
2-036	M6 Overload
2-037	M7 Overload
2-038	M10 Overload
2-041	M1 Overcurrent
2-042	M2 Overcurrent
2-043	M3 Overcurrent

FAULT CODE DISPLAY - CONTINUED

Fault Code	Description
<i>E3 Power Module Faults - continued</i>	
2-044	M4 Overcurrent
2-045	M5 Overcurrent
2-046	M6 Overcurrent
2-047	M7 Overcurrent
2-048	M10 Overcurrent
2-051	M1 Mosfet Short
2-052	M2 Mosfet Short
2-053	M3 Mosfet Short
2-054	M4 Mosfet Short
2-055	M5 Mosfet Short
2-056	M6 Mosfet Short
2-057	M7 Mosfet Short
2-058	M10 Mosfet Short
2-061	M1 Current Sensor
2-062	M2 Current Sensor
2-063	M3 Current Sensor
2-064	M4 Current Sensor
2-065	M5 Current Sensor
2-066	OverTemp Cutoff
2-067	UnderTemp Cutoff
2-071	M1 Overload Trip
2-072	M2 Overload Trip
2-073	M3 Overload Trip
2-074	M4 Overload Trip
2-075	M5 Overload Trip
2-076	M6 Stall
2-077	M7 Stall
2-078	M10 Stall
2-081	EEPROM Fault
2-082	PDO Timeout
2-083	CAN Bus
2-084	Actuator Timeout
2-086	OverTemp Cutback
2-087	UnderTemp Cutback
2-088	K2 Coil Open
2-091	M1 HW Fault
2-092	M2 HW Fault
2-093	M3 HW Fault
2-094	M4 HW Fault
2-095	M5 HW Fault
2-096	Parameter Change
2-097	M6 Current Sensor
2-098	M7 Current Sensor
2-101	M10 Current Sensor
2-102	Thermal Sensor
2-103	K2 Coil Short

Fault Code	Description
<i>E4 Drive Controller Faults</i>	
3-001	E4 Timeout
3-012	Control Overcurrent
3-013	Current Sensor
3-014	Precharge Fail
3-015	Severe UnderTemp
3-016	Severe OverTemp
3-017	Severe UnderVolt
3-018	Severe OverVolt
3-022	OverTemp Cutback
3-023	UnderVolt Cutback
3-024	OverVolt Cutback
3-025	+5V Fault
3-028	Motor Hot Cutback
3-029	Motor Temp Sensor
3-031	K3 Coil Fault
3-032	EM Brake Fault
3-036	Encoder Fault
3-037	Motor Open
3-038	K3 Weld
3-039	K3 Contact Open
3-041	Pedal Open
3-042	Pedal Short
3-045	Pot Low Overcurrent
3-046	EEPROM Fault
3-047	HPD Fault
3-049	Parameter Change
3-051	Pedal Disable
3-056	Low BDI
3-057	EM Brake Type
3-068	VCL Fault
3-069	Supply Fault
3-071	OS General
3-072	PDO Timeout
3-073	Stall
3-077	Supervisor Fault
3-078	Supervisor Incompatible
3-087	Motor Character
3-088	Encoder Pulse Fault
3-089	Motor Type
3-091	VCL/OS Mismatch
3-092	EM Brake Not Set
3-093	Encoder LOS

FAULT CODE HISTORY

Every fault code that occurs is recorded by the machine and kept in a history log. See Figures 15A-15D. To view the fault history press the Information Switch (D) to bring up the information menu. Use the four Navigation Arrows (D1) (up, down, left & right) to move through the menu and the information switch to exit the menu.

Scroll down to Faults, right arrow to select.

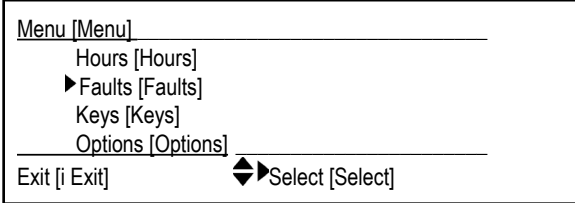
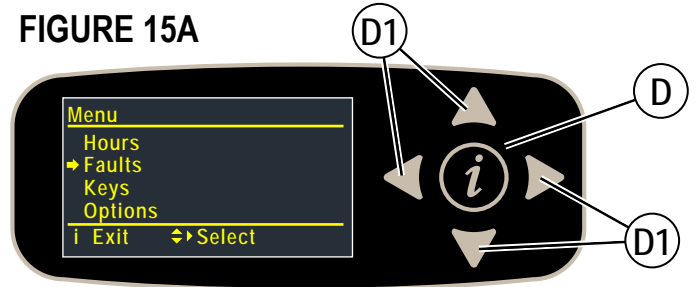

FIGURE 15A



Scroll down to Fault History, right arrow to select.

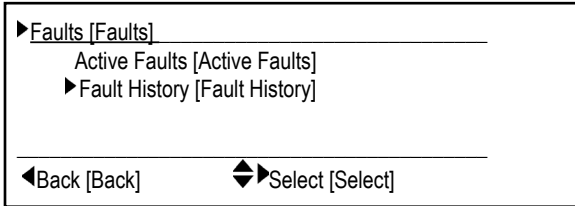
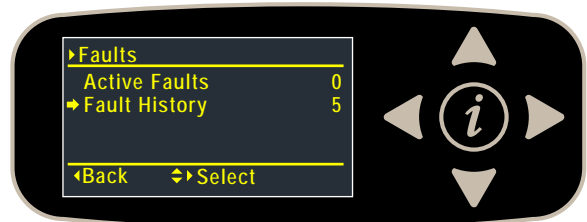

FIGURE 15B



A list of all faults and corresponding timestamp will be displayed, scroll up or down to an individual fault, right arrow for more information.

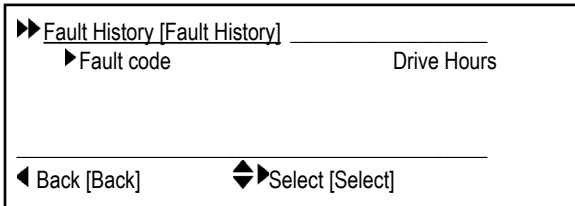
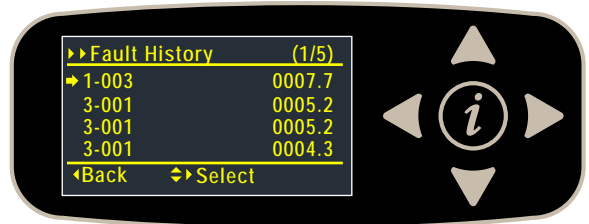

FIGURE 15C



The fault is displayed along with the timestamp and description. Use the up and down arrows to scroll through the list of faults.

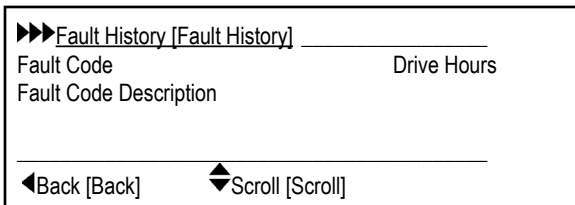
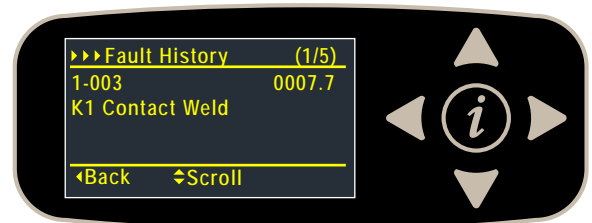

FIGURE 15D



ACCESSORIES / OPTIONS

In addition to the standard components, the machine can be equipped with the following accessories/options, according to the machine specific use:

Brushes with harder or softer bristles	Operator Foot Guard Kit
Squeegee and side blades with different material	Back-Up Alarm Kit
Dual Vacuum Motor Kit	Vacuum Wand Kit
Warning Beacon Kit	Headlight Kit
Deluxe Seat Kit	Squeegee Guard Kit
Overhead Guard Kit	Dust Guard Kit
Seat Belt Kit	Detergent Metering Kit
Battery Watering Kit	Heavy Duty Front Bumper Kit
Wash Hose Kit	Mop Holder Kit
Onboard Charger Kit	USB Kit
TrackClean Kit	Side Sweep Kit
Solution Auto-Fill Kit	

For further information about the above-mentioned accessories, contact an authorized Retailer.

Material Composition and Recyclability		
Type	% of machine weight	% recyclable
Aluminum	4%	100%
Electrical / motors / engines - misc.	12%	90%
Ferrous metals	47%	100%
Harnesses / cables	1%	80%
Liquids	0%	0%
Plastic - non-recyclable	7%	0%
Plastic - recyclable	4%	100%
Polyethylene	24%	100%
Rubber	1%	0%

SOLUTION FLOW RATES

	Standard Flow Rates*			Override Flow Rate**
	1 bar	2 bars	3 bars	4 bars
36" Cylindrical	0.70 GPM / 2.6 liters/minute	0.84 GPM / 3.1 liters/minute	1.00 GPM / 3.7 liters/minute	2.50 GPM / 9.4 liters/minute
34" Disc	0.70 GPM / 2.6 liters/minute	0.84 GPM / 3.1 liters/minute	1.00 GPM / 3.7 liters/minute	2.50 GPM / 9.4 liters/minute
40" Disc	0.84 GPM / 3.1 liters/minute	1.00 GPM / 3.7 liters/minute	1.50 GPM / 5.6 liters/minute	2.50 GPM / 9.4 liters/minute

*These values are for Fixed Flow mode with a full solution tank.

**These are maximum values with a full solution tank.

TECHNICAL SPECIFICATIONS (AS INSTALLED AND TESTED ON THE UNIT)

Model		SC6000 36C	SC6000 34D	SC6000 40D
Model No.		56116000	56116002	56116001
Voltage, Batteries	V	36V	36V	36V
Battery Capacity (max)	Ah	420	420	420
Protection Grade, Operating		Class 3	Class 3	Class 3
Protection Grade, Charging		Class 1	Class 1	Class 1
Sound Pressure Level IEC 60335-2-72: 2002 Amend. 1:2005, ISO 11203, ISO 3744	dB(A)/20µPa	69	69	69
Sound Pressure level - KpA (IEC 60335-2-72, ISO 11203) Uncertainty	dB(A)	3.0	3.0	3.0
Gross Vehicle Weight*	lbs / kg	2359 / 1070	2359 / 1070	2359 / 1070
Transportation Weight**	lbs / kg	1784 / 810	1784 / 810	1784 / 810
Maximum Wheel Floor Loading (center front)	psi / kg/cm ²	120 / 8.43	104 / 7.31	120 / 8.43
Maximum Wheel Floor Loading (right rear)	psi / kg/cm ²	128 / 8.99	121 / 8.50	128 / 8.99
Maximum Wheel Floor Loading (left rear)	psi / kg/cm ²	110 / 7.73	109 / 7.66	110 / 7.73
Vibrations at the Hand Controls (ISO 5349-1)	m/s ²	<2.5	<2.5	<2.5
Vibrations at the Seat (EN 1032)	m/s ²	<0.04	<0.02	<0.02
Gradeability Transport		18.5% (10.5°)	18.5% (10.5°)	18.5% (10.5°)
Gradeability Cleaning		12.2% (7°)	12.2% (7°)	12.2% (7°)
Machine Length	inch / cm		70 / 178	
Machine Height	inch / cm		62.3 / 158	
Machine Height (w/overhead guard)	inch / cm		82 / 208	
Machine Width	inch / cm	46 / 117	39 / 99	46 / 117
Machine Width with Squeegee	inch / cm	48.5 / 123 "K"	43 / 109 "J"	48.5 / 123 "K"
Minimum Aisle Turn Width	inch / cm		79.5 / 202	
Solution Tank Capacity	Gallon / L		50 / 190	
Recovery Tank Capacity	Gallon / L		47 / 178	
Transport Speed (Fwd. Maximum)	mph / kph		5.6 / 9.0	
Transport Speed (Rev. Maximum)	mph / kph		2.6 / 4.2	
Battery Compartment Size (approximate)				
Height (maximum)	inch / cm		17.25 / 43.8	
Width (maximum)	inch / cm		22 / 55.9	
Length (maximum)	inch / cm		24 / 61	
Scrub brush size				
Outside Scrub Brush Diameter - Cylindrical (inside core is 3.5 in / 8.9 cm)	inch / cm	7.1 / 18	—	—
Scrub Brush Length - Cylindrical (two brushes per machine)	inch / cm	35.58 / 90.4	—	—
Brush Diameter - Disc	inch / cm	—	(Quantity of 2) at 17 / 43	(Quantity of 2) at 20 / 51
Scrub Brush Speed	Cylindrical	RPM	760	—
	Disc	RPM	—	250
Hopper Capacity - Cylindrical	in ³ / L	744 / 12.2	—	—
Cleaning Path Width (scrubbing path)	inch / cm	36 / 91.4	34 / 86.3	40 / 101.6
Sweeping Path with optional side broom - Cylindrical	inch / cm	40 / 101.6	—	—

*Gross Vehicle Weight: Standard machine without options, full solution tank and empty recovery tank, with removable scrub brushes, batteries installed and 75 kg operator.

**Transportation Weight: Standard machine without options, empty solution and recovery tanks, with batteries installed and no operator.



Advance

9435 Winnetka Ave North
Minneapolis, MN 55445
www.advance-us.com
Phone: 800-989-2235
Fax: 800-989-6566
©2016 Nilfisk, Inc.

A Nilfisk Brand