

SERVICE MANUAL

250 & GTX SERIES

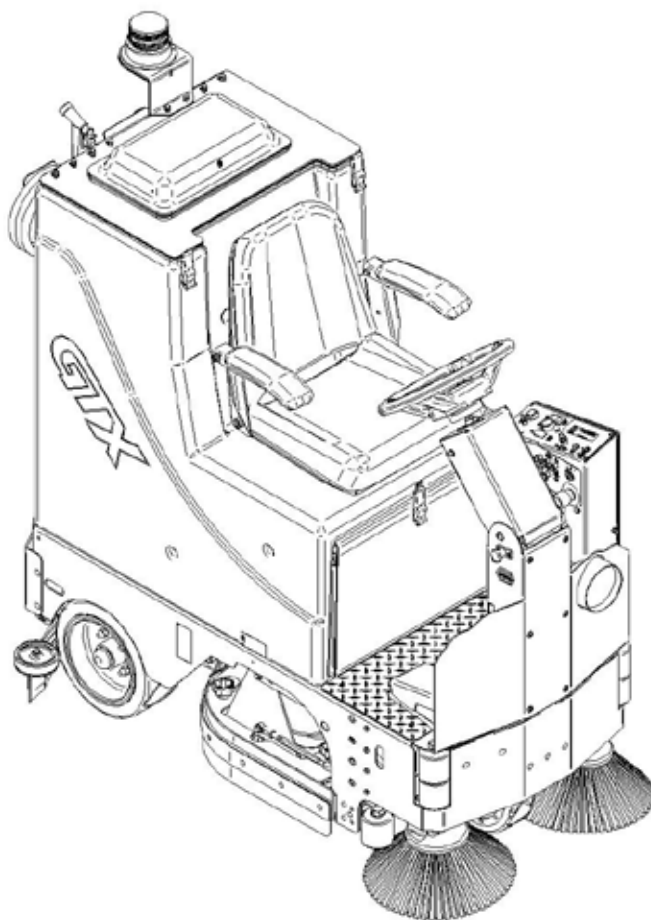

RPS Corporation
P.O. Box 241
Racine, Wisconsin

Phone: 1-800-450-9824
Fax: 1-866-632-6961
email: info@factorycat.com

www.factorycat.com
www.tomcatequip.com

CAUTION!

To reduce the chance of personal injury and/or property damage, the following instructions must be carefully observed:

Proper service and repair are important to the safety of the service technician and the safe reliable operation of all cleaning equipment. If part replacement is necessary, the part must be replaced with one of the same part number or with an equivalent part. Do not use replacement parts of lesser quality.

The service procedures recommended and described in this service manual are effective methods of performing service and repair. Some of these procedures require the use of tools specifically designed for the purpose.

Accordingly anyone who intends to use a replacement part, service procedure or tool which is not recommended by the equipment manufacturer, must determine that neither his safety nor the safe operation of the equipment will be jeopardized by the replacement part, service procedure or tool selected.

It is important to note that this manual contains various cautions and notices that must be carefully observed in order to reduce the risk of personal injury during service or repair, or the possibility that improper service or repair may damage the piece of equipment or render it unsafe. It is also important to note that these 'Cautions' and 'Notices' are not exhaustive, because it is impossible to warn of all the possible hazardous consequences that might result from failure to follow these instructions.

TOMCAT SERVICE MANUALS ARE INTENDED FOR USE BY PROFESSIONAL, QUALIFIED TECHNICIANS. ATTEMPTING REPAIRS OR SERVICE WITHOUT THE APPROPRIATE TRAINING, TOOLS, AND EQUIPMENT COULD CAUSE INJURY TO YOU OR OTHERS AND DAMAGE TO YOUR PIECE OF EQUIPMENT THAT MAY CAUSE IT NOT TO OPERATE PROPERLY

This manual should be kept in a convenient place for easy reference. When properly used, it will meet the needs of technicians and equipment owners.

No part of this publication may be reproduced, stored in any retrieval system, or transmitted, on any form or by any means, including but not limited to electronic, mechanical, photocopying, recording or otherwise, without the prior written permission of the Mid-Central Corporation. This includes all text, illustrations, tables and charts.

©2008 Mid-Central Corporation
Printed in U.S.A.

As our policy is one of constant improvement, all specifications are subject to change without notice.

SAFETY MESSAGE

Your safety and the safety of others is very important and operating this unit safely is an important responsibility.

To help you make informed decisions about safety, we have provided operation procedures and other safety information in this manual. This information informs you of potential hazards that could hurt you or others.

It is not practical or possible to warn you of all the hazards associated with operating this unit. You must use your own good judgement.

This is intended for commercial use. It is designed to be used on hard floors only and in an indoor environment, with the recommended pads and brushes with approved cleaning solutions.

DO NOT OPERATE THE UNIT:

UNLESS TRAINED AND AUTHORIZED.
UNLESS OPERATOR MANUAL IS READ AND UNDERSTOOD.
IF UNIT IS NOT IN PROPER OPERATING CONDITION.

WHEN OPERATING UNIT:

WEAR PROPER PROTECTIVE EQUIPMENT.
REMOVE LOOSE OBJECTS FROM THE FLOOR THAT MAY BE PROJECTED FROM THE REVOLVING BRUSHES.
DO NOT OPERATE THE MACHINE WHERE FLAMMABLE LIQUIDS OR GASES ARE PRESENT.
USE EXTREME CAUTION WHEN MANEUVERING.
MAKE SURE ALL PERSONS ARE A SAFE DISTANCE FROM THE MACHINE WHILE IN OPERATION.

BEFORE LEAVING THE UNIT:

MAKE SURE MACHINE IS TURNED OFF.
PARK MACHINE ON A LEVEL SURFACE.
DISCONNECT BATTERIES.

BEFORE SERVICING:

STOP ON A LEVEL SURFACE AND SECURE MACHINE.
DISCONNECT BATTERIES.

SAFETY PRECAUTIONS

- Hazardous voltage. Shock, Burns or electrocution can result. ALWAYS disconnect the batteries before servicing machine.
- Batteries emit hydrogen gases, explosion or fire can result. Keep sparks and open flame away!
- Charge unit in a well ventilated area and keep battery compartment open when charging or explosion or fire could result.
- Battery acid can cause burns. Wear protective face-shield and gloves when servicing batteries.
- Do not store outdoors or pressure wash. Prevent from getting electrical components wet.
- The use of part and solutions other than recommended by the manufacturer may cause property damage, bodily injury or death to yourself or others.
- Dress safely. Do not wear rings, watches or other jewelry while working on this machine. They can cause an electrical short which can cause serious burns, other injury or death.
- Do not work on this machine while wearing a tie, scarf, hat or any other loose or dangling neck wear or clothing. Loose clothing can tangle or catch on rotating parts causing serious injury or death.
- Do not use this machine as a ladder or a chair.
- Operate this machine only from the operators position.
- This machine was not designed to carry passengers or transport cargo.
- Do not operate this machine on steep ramps or uneven surfaces. When climbing a ramp always drive the machine forward straight up or down the ramp. Never drive across the incline.
- Do not back down or turn on ramps!
- Always use the charger provided by the manufacturer to charge the machine. It is an automatic charger specifically designed to charge at the appropriate rate. If you must use a different charger, disconnect the batteries from the machine as this will protect the on-board electronics.
- Understand the dynamic breaking system before you operate the machine on ramps or slopes.
- Do not park the machine on ramps or slopes
- Do not operate the machine if any parts have been removed or damaged.
- Do not remove, paint over, or destroy warning decals. If warning decals become damaged they must be replaced.
- Do not operate machine in an unsafe condition. If the machine is need of repair or is in anyway unsafe to operate, the matter should be reported immediately to the shift supervisor. Do not operate the machine until it is returned to proper operating condition.
- This machine must be operated only by a trained operator. As part of their training they must read the operators manual thoroughly. If extra copies are needed contact your local dealer.
- Always park machine on a level surface and turn the power off before leaving it unattended.
- Do not operate over electrical floor outlets. This may result in serious injury or death to the operator and others.
- Do not work under machine without it properly supported on suitable safety stands.
- Do not try and lift this machine unaided it is very heavy.
- Do not use handle bars or steering mechanism as a lifting point

BLANK
THIS PAGE WAS INTENTIONALLY LEFT BLANK

CONTENTS

<u>MAINTENANCE</u>	1-1
LUBRICATION	1-1
<u>SQUEEGEE SYSTEM</u>	3-1
SQUEEGEE SYSTEM COMPONENTS	3-1
TRIANGLE PLATE & TOW BAR	3-3
UP/DOWN MOVEMENT	3-3
SIDEWAYS MOVEMENT	3-3
SQUEEGEE BLADES.....	3-3
REPLACING BLADES.....	3-4
ORDERING BLADES.....	3-4
SQUEEGEE ADJUSTMENT	3-5
PITCH ADJUSTMENT KNOB.....	3-5
<u>SQUEEGEE LIFT SYSTEM</u>	4-1
SWITCH OPERATION	4-1
SQUEEGEE SWITCH	4-1
UNI-TOUCH SWITCH	4-1
SQUEEGEE LIFT OPERATION.....	4-2
OFF BOARD VACUUM SWITCH	4-2
SQUEEGEE LIFT ADJUSTMENT	4-3
LIMIT SWITCH ADJUSTMENT	4-3
<u>RECOVERY SYSTEM</u>	5-1
DRAIN SAVER.....	5-1
RECOVERY TANK.....	5-1
VACUUM FLOATS	5-1
VACUUM SAVER.....	5-1
VACUUM MOTOR.....	5-1
OVERFILL / BLOCKAGE ALERT SYSTEMS	5-2
AUDIBLE SYSTEM	5-2
VISUAL ALERT.....	5-2
DRAIN HOSE.....	5-2

SOLUTION SYSTEM - GENERAL INFORMATION **6-1**

BRUSH DRIVE SYSTEM **7-1**

DISC 7-1

CYLINDRICAL 7-1

BRUSH DRIVE ELECTRICAL CIRCUIT 7-1

SETTING BRUSH PRESSURE 7-2

INSTALLING & REMOVING BRUSHES 7-3

DISC MACHINES..... 7-3

CYLINDRICAL DECK..... 7-3

BRUSH LIFT SYSTEM **8-1**

BRUSH LIFT ELECTRICAL CIRCUIT 8-1

DOWN PRESSURE 8-2

BRUSH DECK ADJUSTMENT 8-3

ADJUSTING DECK HEIGHT 8-3

TRACTION DRIVE SYSTEM **9-1**

GEAR RESEARCH - 1ST DESIGN 9-1

GEAR RESEARCH - 2ND DESIGN 9-1

METAL ROTA..... 9-1

TRACTION DRIVE ELECTRICAL CIRCUIT 9-2

DRIVE MOTOR 9-2

GEAR RESEARCH 1ST DESIGN 9-2

TIRES & WHEELS 9-2

PARKING BRAKE 9-2

CHASSIS SYSTEM **10-1**

REAR AXLE..... 10-1

REAR BUMPER..... 10-1

SIDE BROOMS..... 10-1

BATTERY SAFETY	11-1
DANGER OF EXPLODING BATTERIES	11-1
SAFE CHARGING	11-1
HANDLING BATTERY ACID	11-2
WATER.....	11-2
BATTERY TERMINAL TYPES.....	11-2
TAPERED TOP TERMINAL (S.A.E. POST)	11-2
STUD TERMINAL	11-3
COMBINATION TERMINAL.....	11-3
THE “L” TERMINAL	11-3
BATTERY SYSTEM	11-4
BATTERY MAINTENANCE & CARE	11-4
LEAD ACID BATTERIES (TRADITIONAL).....	11-4
LEAD ACID BATTERIES (MAINTENANCE FREE)	11-4
GEL CELL BATTERIES.....	11-4
BATTERY CABLES & TERMINALS	11-5
BATTERY TESTING	11-5
HYDROMETERS	11-5
BATTERY REPLACEMENT	11-8
BATTERY CHARGERS	11-8
OFF-BOARD CHARGER.....	11-8
ON BOARD CHARGERS	11-9
ELECTRICAL SYSTEM	12-1
BATTERY SYSTEM	12-1
SWITCHES	12-1
RELAYS	12-1
CONTACTORS.....	12-3
MOTORS.....	12-3
BRUSH DECK MOTORS.....	12-3
VACUUM MOTORS	12-3
ACTUATORS	12-4
WIRING	12-4
STANDARD CRIMP ON TERMINALS.....	12-4
MOLEX CONNECTORS	12-4
CONTROLLER HIGH AMP OUTPUT TERMINALS	12-5
ANDERSON BATTERY CONNECTORS	12-5

COMPUTER CONTROL SYSTEM	13-1
CONTROLLER OVERVIEW	13-1
INPUTS	13-1
OUTPUTS	13-1
PULSE WIDTH MODULATION	13-1
CONTINUITY TESTING	13-1
SOFT START	13-2
CONNECTIONS	13-2
MOLEX MINI FIT JR.	13-2
AMP TERMINALS	13-2
BINDING POST TERMINALS	13-2
TIMED CIRCUITS	13-2
BATTERY METER	13-2
DOWN PRESSURE CONTROL	13-2
LCD DISPLAY	13-3
VERSION 1	13-3
SCREEN 1	13-3
SCREEN 2	13-4
SCREEN 3	13-4
SCREEN 4	13-4
VERSION 2	13-5
SCREEN 1	13-5
SCREEN 2	13-6
SCREEN 3	13-6
SCREEN 4	13-6

VERSION 3	13-7
SCREEN 1	13-7
SCREEN 2	13-8
VERSION 4	13-9
SCREEN 1	13-9
SCREEN 2	13-10
ON BOARD DIAGNOSTICS	13-11
DIAGNOSING THE CONTROL SYSTEM	13-11
METERS	13-11
MEASUREMENTS.....	13-11
LCD DISPLAY.....	13-11
INPUTS	13-11
TRI-STATE LOGIC	13-12
INPUTS- VARIABLE VOLTAGE	13-12
OUTPUTS	13-12
PROGRAMMING	13-13

BLANK

THIS PAGE WAS INTENTIONALLY LEFT BLANK

SPECIFICATIONS

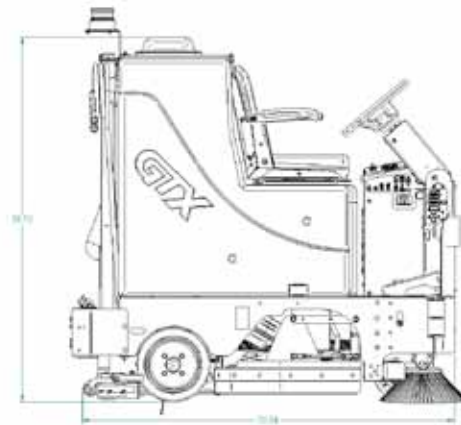
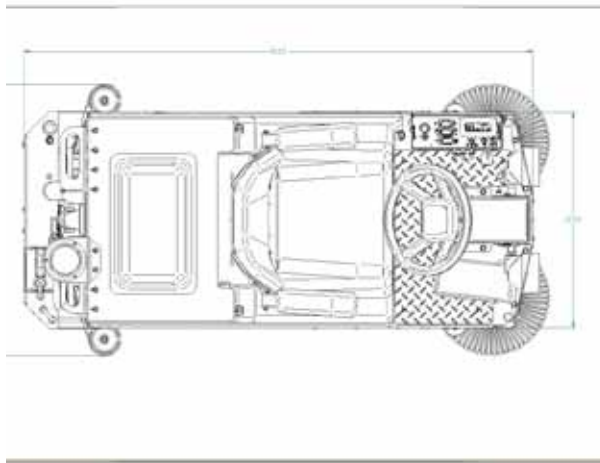

Machine Length	54 in.	(149cm)
Machine Height	55 in.	(102cm)
Machine Chassis Width	26 in.	(62 cm)
Machine Current Consumption (Average)	65 Amps	Brush Motor: Up to 70 Amps Vacuum Motor: Up to 60 Amps Transport Drive: Up to 150 Amps
Solution Tank Capacity	35 Gallons	(114 liters)
Recovery Tank Capacity	35 Gallons	(114 liters)
Solution Flow Rate	0 - 2 GPM	(0 - 7.56 liters/min)
Operating Noise Level (at operator)	68 dB(A)	
Forward Scrub Speed	0 - 350 ft.min (5) mph	(0- 92 meters / min (7.5 kph))
Vacuum Motor Power	1.0 hp or 2.0 hp	
Water lift	68"	
Airflow	95 or 180 cfm	
Power Source (Batteries)		
Standard	(6) 6 Volt / 245 amp hour capacity	
Weight (Each)	125 lbs. (30 kg)	
Heavy Duty	(6) 6 Volt / 325 amp hour capacity	
Weight (Each)	1200 lbs. (56kg)	
Battery Compartment Size		
Height	13 in. (33 cm)	
Width	14 in. (35.5 cm)	
Length	17 in. (43 cm)	
Estimated Battery Run Time	Up to 7.5 hours.	
Battery Charger		
Standard 115 VAC	36 Volt / 36 amp	
On-Board 115 VAC	36 Volt / 20 amp	
Rapid Charger	36 Volt / 80 amp	

SPECIFICATIONS

	24" Cylindrical	26" Disk	27" Cylindrical	30" Disk	30" Cylindrical	34" Cylindrical
Machine Width with Squeegee	32 in. 81 cm	32 in. 81 cm	35 in. 89 cm	35 in. 89 cm	38 in. 97 mm	38 in. 97 mm
Scrub Brush Size (qty. 2)	23 x 5 in. 58 x 14 cm	20 in. 56 cm	26 x 5 in. 67 x 14 cm	15 in. 59 cm	29 X 5 in. 74 mm	33 X 5 in. 84 mm
Scrub Brush Motor (qty. 2)	1.5 hp	1.5 hp	1.5 hp	1.5 hp	1.5 hp	1,5 hp
Scrub Brush Speed	750 rpm	270 rpm	750 rpm	270 rpm	750 rpm	750 rpm
Machine Net Weight *	780 lbs. 354 kg.	880 lbs. 399 kg.	1004 lbs. 455 kg.	1,095 lbs. 497 kg.	1,095 lbs. 497 kg.	1,271 lbs. 577 kg.
Machine Gross Weight **	1,222 lbs. 554 kg.	1,322 lbs. 600 kg.	1,446 lbs. 656 kg.	1,537 lbs. 698 kg.	1,537 lbs 698 kg	1,713 lbs 777 kg
Cleaning Width	24 in. 61 cm	26 in. 66 cm	in. 69 cm	43 in. 76 cm	30 in. 00 cm	34 in. 00 cm
Cleaning Rate Per Hour (MAX)	26,400 sq. ft./hr 2415 sq. meters./hr	27,900 sq. ft./hr 2415 sq. meters./hr	29,600 sq. ft./hr 2787 sq. meters./hr.	33,000 sq. ft./hr 2787 sq. meters./hr.	33,000 sq. ft./hr 2787 sq. meters./hr.	36,400 sq. ft./hr 2787 sq. meters./hr.

* NET WEIGHT: Standard equipped machine with no options installed. Empty recovery and solution tanks and no batteries, pad holder or scrub brush.

** GROSS WEIGHT: Standard equipped machine with no options installed. Full solution and empty recovery tank. Standard pad holder or scrub brush and standard batteries.

MAINTENANCE

MAINTENANCE SCHEDULE	DAILY	WEEKLY	MONTHLY	EVERY 200 HRS
Charge the batteries	X			
Inspect pad or brush condition	X			
Drain and clean out tanks and hoses	X			
Clean float screen & drain saver in recovery tank	X			
Remove and clean squeegee tool. Inspect for wear or damage.	X			
Wipe down outside of machine	X			
Check battery electrolyte level in all cells		X		
Check all skirts and wipers on machine		X		
Check batteries and terminals for irregularities		X		
Lubricate machine			X	
Check carbon brushes on motors				X
Blow out dust from motors			X	

ATTENTION!

Make sure machine is turned off and the batteries are disconnected before performing and repairs or service on the machine.

The 250 machines have numerous brush type motors that require periodic inspection to assess wear. Failure to inspect on a regular intervals can result in motor damage that is not covered under warranty.

LUBRICATION

This machine requires periodic lubrication of it's pivot points and threads. Once a month is generally acceptable unless the machine is used in a severe duty application.

The folowing points should be oiled:

- Squeegee knob threads
- Squeegee adjustment threads
- Squeegee pivot points
- Brush head pivot points

GTX SERIES PREVENTIVE MAINTENANCE WORKSHEET

CUSTOMER INFORMATION		
CUSTOMER		
ADDRESS		
CITY	STATE	ZIP CODE

MACHINE INFORMATION	
MODEL #	SERIAL #
WORK ORDER#	HOUR METER:

BATTERY CONDITION	Cell #1	Cell #2	Cell #3
Battery # 1 Hydrometer Reading			
Battery # 1 Water Condition			
Battery # 2 Hydrometer Reading			
Battery # 2 Water condition			
Battery # 3 Hydrometer Reading			
Battery # 3 Water Condition			
Battery # 4 Hydrometer Reading			
Battery # 4 Water condition			
Battery # 5 Hydrometer Reading			
Battery # 5 Water Condition			
Battery # 6 Hydrometer Reading			
Battery # 6 Water Condition			

Clean Battery Tops. Check Battery Cable and Terminal Condition
NOTES:

BRUSH CONDITION				
Scrub Brush Fiber Length		Rotated Brushes		
Drive Socket	Good	Worn	Needs Replacement	
Drive Hub	Good	Worn	Needs Replacement	
Side Broom Condition	Good	Worn	Needs Replacement	Rotated Side to Side

CHECK OPERATION AND CONDITION OF:	IN SPEC	REPAIR	PROBLEM
Steering wheel Tilt Mechanism			
Key Switch			
Horn			
Head Light			
LCD Display			
Page Button			
Brush Pressure Button			
Brush Pressure Managers Lock Out			
Foot Pedal			
Reverse Switch			
Back Up Alarm			
One Touch Switch			

GTX SERIES
PREVENTIVE MAINTENANCE WORKSHEET

CHECK OPERATION AND CONDITION OF:	IN SPEC	REPAIR	PROBLEM
Brush Switch			
Solution Potentiometer			
Solution Solenoid			
Solution Drain Valve			
Brush Deck Lift System			
Brush Motors & Motor Brushes			
Vacuum Switch			
Vacuum Motor performance			
Off-Board Vac Switch			
Squeegee Lift System			
Squeegee Adjustment			
Squeegee Blades			
High Recovery Light			
High Recovery Alarm			
Drain Hose and Plug			
Side Broom Operation			
Spray Jet Switch			
Spray Jet Pump, Hose & Nozzle			
Strobe Light			
Battery Charger Connectors			
Battery Charger			

CLEAN AND/OR LUBRICATE	IN SPEC	REPAIR	PROBLEM
Solution Filter			
Squeegee pivot points & Knobs			
Scrub Deck Linkage			

VISUALLY INSPECT:	IN SPEC	REPAIR	PROBLEM
Solution Tank Condition			
Recovery Tank & Lid Condition			
Drain Saver			
Vacuum float			
Vacuum Motor Brushes			
Vacuum Hoses			
Solution Hoses			
Blade retainers & hardware			
Squeegee Wheels			
Brush skirts			
Brush Motor Brushes			
Brush or Pad Driver Condition			
Drive Wheel Condition			
Rear Wheels Condition			
All Rollers			

GTX SERIES PREVENTIVE MAINTENANCE WORKSHEET

COMMENTS

Technician's Name _____

Technician's Signature _____

Date _____

Customer's Name: _____

Customer's Signature _____

Date _____

!! Safety Precautions!!

Warning: Hazardous voltage. Shock, burns or electrocution can result. Always disconnect the batteries before servicing machine.

Warning: Batteries emit hydrogen gases, explosion or fire can result. Keep sparks and open flames away.

Warning: Charge unit in a well ventilated area, and keep battery compartment open when charging. Explosion or fire could result.

Warning: Battery acid can cause burns. Wear protective eye wear and gloves when servicing batteries.

Warning: Do not store outdoors or pressure wash. Prevent from getting electronic components wet.

Warning: The use of parts and solutions other than recommended by the manufacturer may cause damage or endanger people.

Warning: Dress safely. Do not wear rings or metal wrist watches while working on this machine. They can cause an electrical short, which can cause serious burns. Do not work on this machine while wearing a tie, scarf or other loose, dangling neckwear or clothing. These loose items can tangle in the rotating parts and cause serious injury or even death.

Warning: Do not use the machine as a step ladder or chair.

Warning: Only operate this machine from the operator's seat. It was not designed to carry passengers.

Warning: Do not operate this machine on ramps or uneven surfaces. When climbing a ramp, always drive the machine in forward straight up or down the ramp. Never drive across the incline. Do not back down or turn on ramps!

Warning: Do not attempt to push or pull the machine without first manually overriding the parking brake and disconnecting both leads to the traction motor.

Warning: Always use the charger provided by the manufacturer to charge the machine. It is an automatic charger, specifically designed to charge at the appropriate rate. If you must use a different charger, disconnect the batteries before charging. This will prevent damage to the electronic speed controller.

Warning: Understand the dynamic braking system before you operate the machine on ramps. Machine does not coast. Releasing the foot pedal will automatically apply braking force, and stop the machine.

Warning: Do not park the machine on ramps or slopes. The machine has a parking brake, but it is recommended that it is always parked on level ground.

Warning: Do not operate the machine if any parts have been removed or damaged.

Warning: Do not remove, paint over, or destroy warning decals. If warning decals become damaged, they must be replaced.

Warning: Do not operate machine in unsafe condition. If the machine is in need of repair or is in any way unsafe to operate, the matter should be reported immediately to the shift supervisor. Do not operate the machine until it is returned to proper operating condition.

Warning: This machine must only be operated by trained operator. As part of his or her training, they must read this manual thoroughly. If extra copies are needed, contact your local dealer.

Warning: Always turn off the machine, before leaving it unattended.

Warning: Do not operate over electrical floor outlets, may result in serious injury.

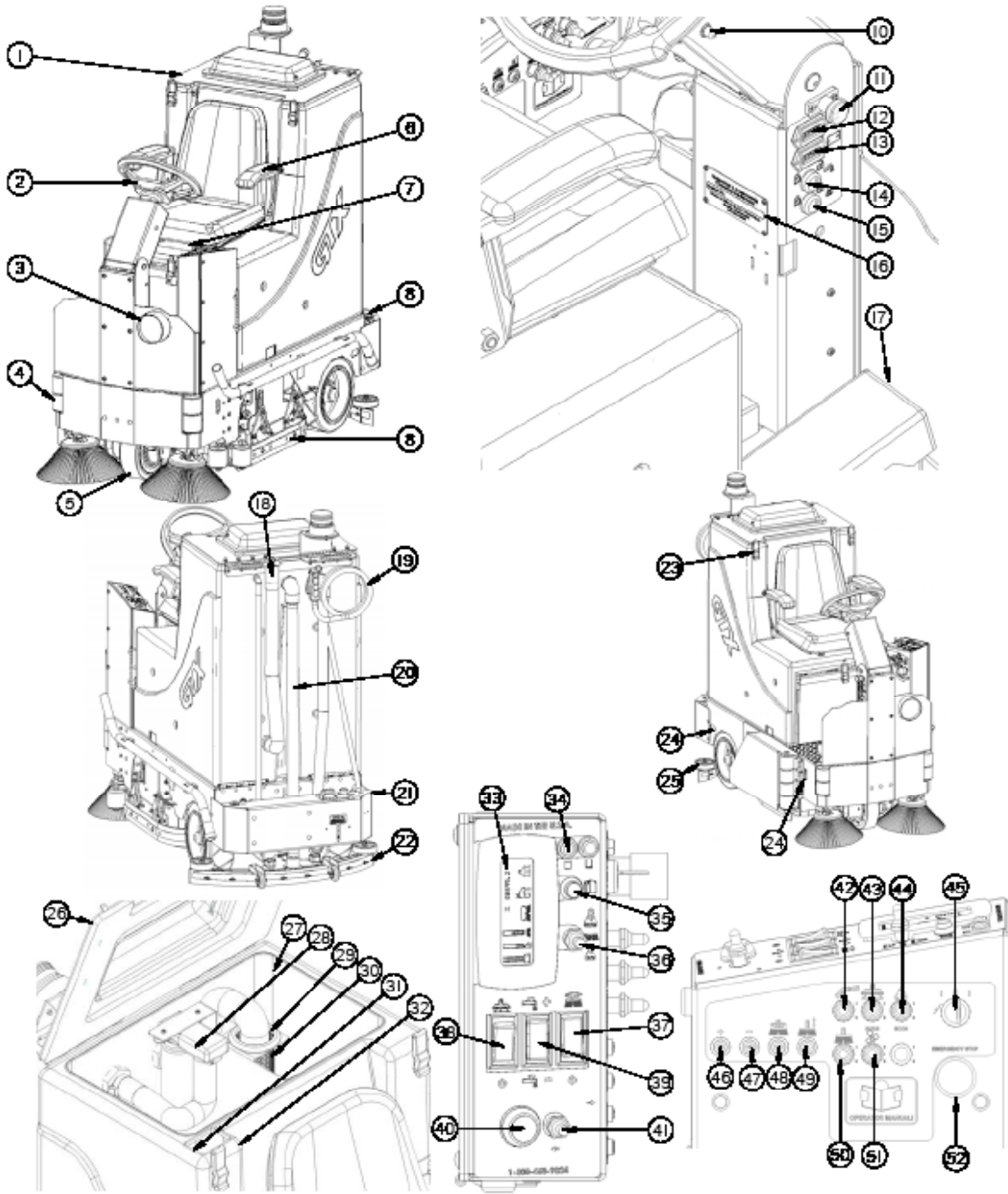

PAGE 7

SCREEN #1

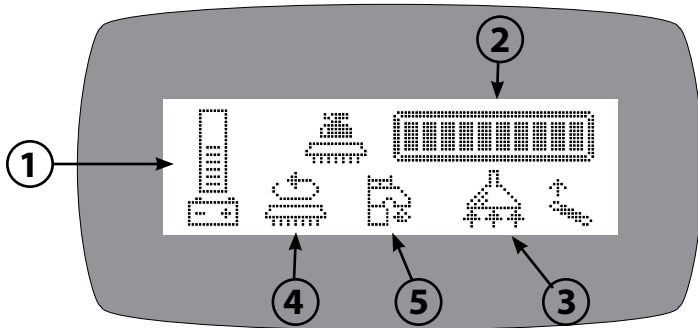

SCREEN #2

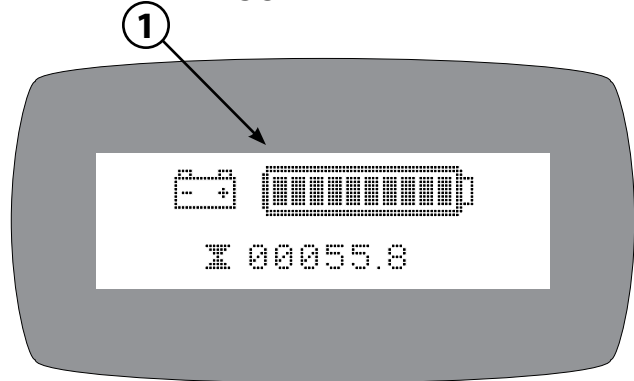

SCREEN #3

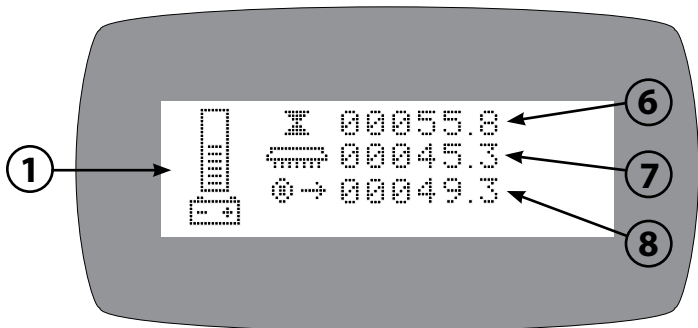

ERROR CODE SCREEN

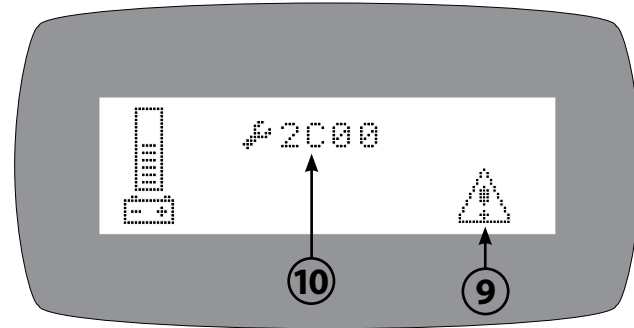

TO CHANGE CYCLE THROUGH SCREENS 1-3 USE THE GREEN PAGE BUTTON NEXT TO THE LCD DISPLAY. THE ERROR CODE SCREEN ONLY APPEARS WHEN THERE IS A PROBLEM WITH THE MACHINE.

1. BATTERY LEVEL INDICATOR: Indicates the amount of charge left in the batteries.
2. SCRUB DECK DOWN PRESSURE INDICATOR: Displays the down pressure setting.
The down pressure has 5 settings.
3. VACUUM MOTOR: Indicates the controller is receiving a request for vacuum.
4. SCRUB MOTOR: Indicates the controller is receiving a request run the scrub motors.
5. SOLUTION ON: Indicates the controller has received a request for solution.
6. KEY SWITCH HOUR METER: Indicates the number of hours the machine has been turned on.
7. SCRUB MOTOR HOUR METER: Indicates the number of hours the scrub motors have been operated on the machine.
8. TRANSPORT HOUR METER: Indicates the total number of hours the drive system has been operated.
9. ERROR WARNING SYMBOL: Indicates when the controller sees a malfunction.
10. DIAGNOSTIC CODE: When the machine has detected an error it will display the warning symbol and a diagnostic code that indicate what system has malfunctioned.

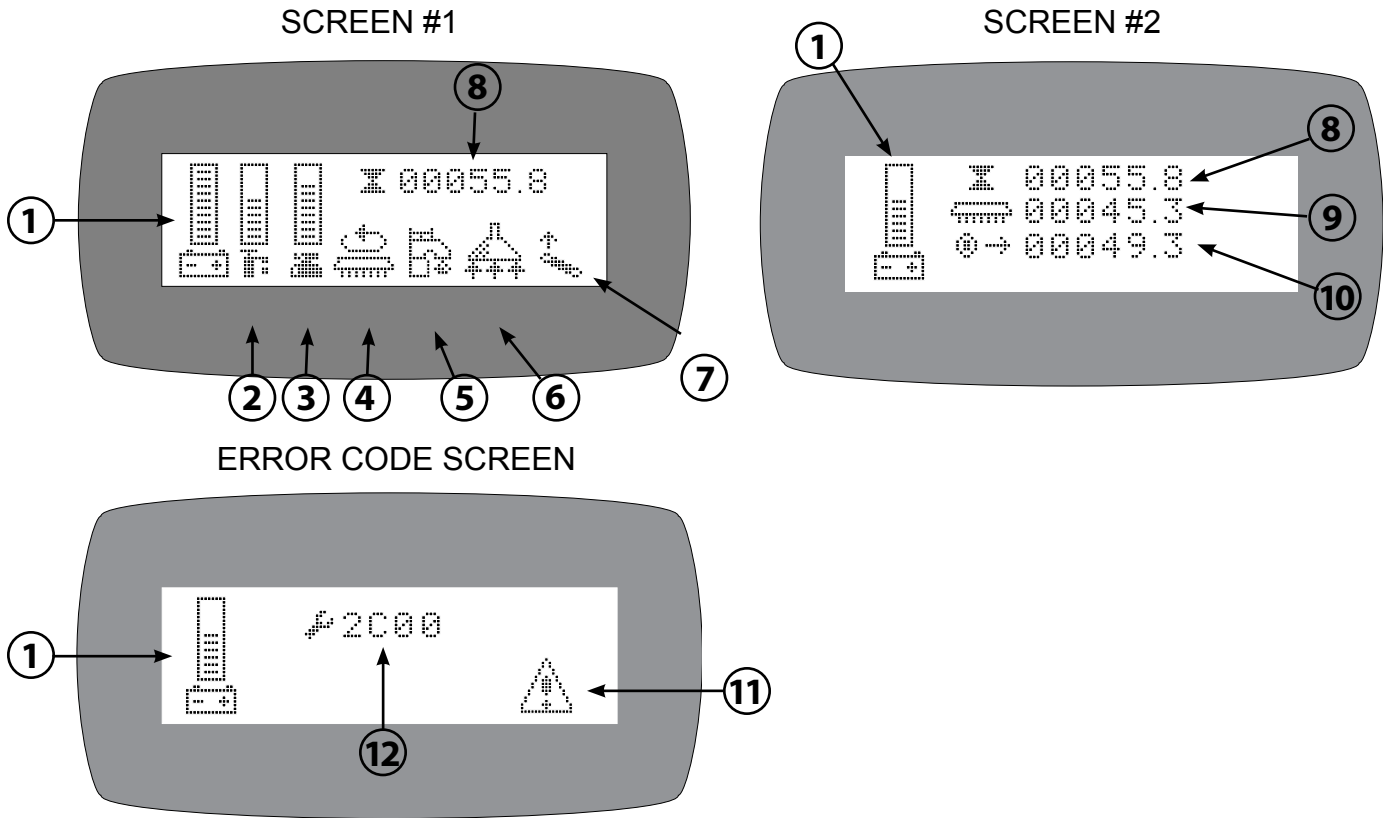

TO CHANGE CYCLE THROUGH SCREENS 1 and 2 USE THE GREEN PAGE BUTTON NEXT TO THE LCD DISPLAY. THE ERROR CODE SCREEN ONLY APPEARS WHEN THERE IS A PROBLEM WITH THE MACHINE.

1. BATTERY LEVEL INDICATOR: Indicates the amount of charge left in the batteries.
2. SOLUTION VOLUME: Indicates the water volume the machine is adjusted to.
3. SCRUB DECK DOWN PRESSURE INDICATOR: Displays the down pressure setting. The down pressure has 5 settings.
4. SCRUB MOTOR: Indicates the controller is receiving a request run the scrub motors.
5. SOLUTION ON: Indicates the controller has received a request for solution.
6. VACUUM MOTOR: Indicates the controller is receiving a request for vacuum.
6. KEY SWITCH HOUR METER: Indicates the number of hours the machine has been turned on.
7. HIGH PEDAL DISABLE: Indicates the number of hours the scrub motors have been operated on the machine.
8. KEY-ON HOUR METER: Indicates the total number of hours the controller has been powered on.
9. SCRUB HOUR METER: Indicates the total number of hours the scrub system has been operated .
10. TRANSPORT HOUR METER: Indicates the total number of hours the drive system has been operated.
11. ERROR WARNING SYMBOL: Indicates when the controller sees a malfunction.
12. DIAGNOSTIC CODE: When the machine has detected an error it will display the warning symbol and a diagnostic code that indicate what system has malfunctioned.

SQUEEGEE SYSTEM

The 250/GTX squeegee system is designed to pick up water and dirt from the floor using air flow created by the vacuum motor(s). The squeegee tool is designed with notches that allow the air, water and dirt to pass through it while metering the air increasing its speed through the tool and recovery system.

The optimal performance is very dependent on proper adjustment and maintenance. The machines recovery system also must be operating properly for the squeegee to perform well.

A vacuum gauge is a handy tool for checking recovery system operation. You should be able to achieve 65" of water lift on most models. Put the vacuum gauge in the end of the squeegee hose to check. If you have questions on this tool setup call the factory at 800-634-4060.

SQUEEGEE SYSTEM COMPONENTS

The squeegee tool with replaceable rollers & blades.

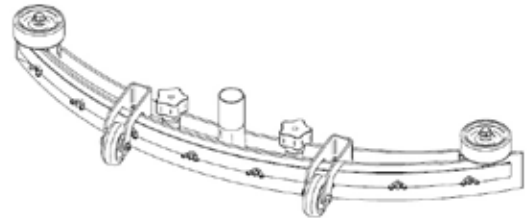

A suspension that mounts the squeegee to the machine, and allows the squeegee to move up and down with variations in the floor, and pivot in turns.

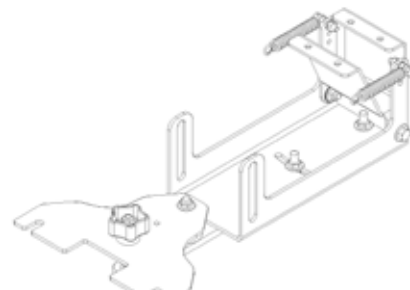

A lift system that allows the operator to raise the squeegee off the floor. The machine has a fully automatic electric lift system.

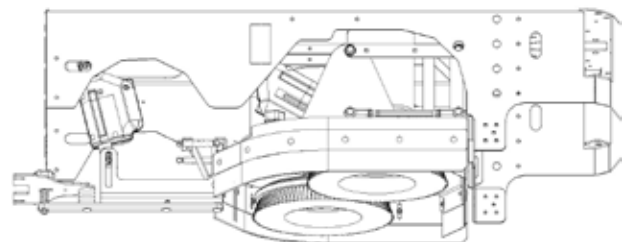

3 SQUEEGEE SYSTEM

A pitch adjustment that allows the operator to adjust the squeegee for different floor surfaces. This is used for creating more of a leak under the front blade for smooth floors or less of one for rough floors.

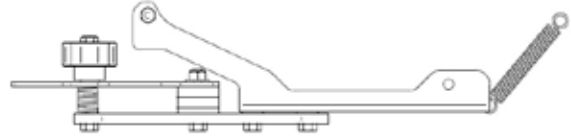

TRIANGLE PLATE & TOW BAR

These parts cannot be bent at all. They must be completely straight and flat. If either is bent replace it.

If you replace the triangle plate, adjust the clearance between the bottom of the plate and the top of the tow bar so clearance is 7/8" (22 mm). Squeegee will not work properly if this adjustment is off!

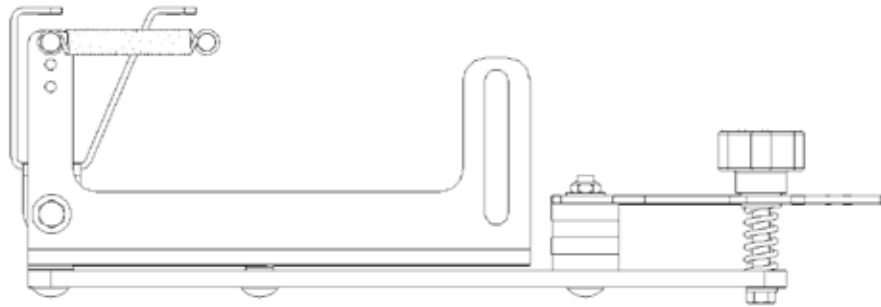

UP/DOWN MOVEMENT

The squeegee must be able to travel up and down freely so it can glide over bumps and uneven floors. It is hinged at the front as shown.

If the squeegee suspension does not move up and down properly check the bolts and the Oilite bushings at the pivot point. If the bolts are too tight (may have been tightened by customer by mistake) or the bushings are dried out or worn the squeegee will not be able to float properly.

SIDEWAYS MOVEMENT

The squeegee must be allowed to move from side to side so that if it hits an obstacle it can move out of the way. If squeegee does not move freely from side to side check the bolt tension on the two pivot bolts. Check that the white plastic washers between the pivot plate and the trailing arm to make sure they are not damaged.

In order for the squeegee system to operate properly the parts have to be assembled properly. **The space between the bottom of the "Squeegee triangle plate" – E, and the "squeegee trail arm" – C, must be exactly 7/8" on all models but the 390, the 390 measurement is 1 3/8".** If this dimension is incorrect you will never get the squeegee blade adjusted properly. If you believe you are having problems with this adjustment, please call the factory: 800 634-4060.

SQUEEGEE BLADES

Squeegee blades are wear items. The back blade wears fastest on the edge that contacts the floor (lower front edge). This blade can ideally be turned four times. It is important to have a sharp squeegee edge on the floor; otherwise the squeegee does not scrape the water off the floor but instead glides right over it.

The front blade wears very well when properly adjusted, but it can get torn. It can be installed one of two ways: “3 notches down” for normal floors, and “5 notches down” for extremely smooth floors.

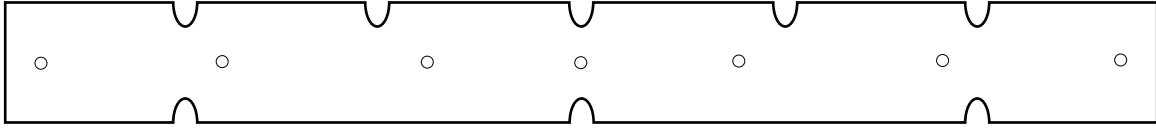

REPLACING BLADES

We stock individual blades or blade kits that include a blade set and new set of squeegee wheels. We recommend changing wheels when you change blades as they are wear items and they are critical to the proper operation of the squeegee.

When installing blades they must be put on without bumps or ripples. The squeegee should have a smooth edge that rides on the floor. When adjusting the blades you need to achieve a uniform “fanning” of the blade from one tip to the other. If the blade does not do this it is installed incorrectly or misadjusted.

When changing or turning squeegee blades it is very important to note the orientation of the stainless steel retaining band for re-installation. The holes are offset to make a wide side and narrow side. The wide side always goes UP. If the band is installed incorrectly the squeegee will not function properly

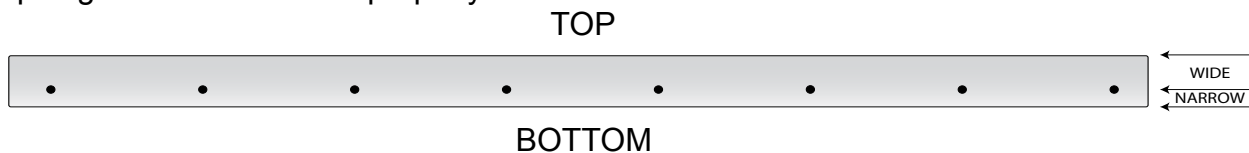

ORDERING BLADES

1. Find the squeegee size:

Check the stamped number on the top of the squeegee body and order blades the corresponding blade size: (32, 35, 38 or 45 inches).

2. Choose the appropriate material:

Gum rubber - These blades are tan in color and best for most applications including irregular floors. They wear out quickly on rough floors however and do not tolerate oil, other petroleum products or heavy citrus cleaners. The kit number suffix for gum rubber is “G”. (Example 28-770-G)

Linatex - These blades are red in color and designed to be very durable while at the same time giving optimum performance. They are very abrasion resistant and perform acceptably on irregular floors. They tolerate oil, petroleum products and heavy citrus cleaners better than gum rubber. The kit number suffix for Linatex is “L”.

Polyurethane - These blades are nearly clear and are recommended for oil, petroleum or heavy citrus cleaner applications where Gum or Linatex would fail. It rarely works as efficiently as Gum or Linatex but is somewhat abrasion resistant. The kit number suffix for polyurethane is “U”.

SQUEEGEE ADJUSTMENT

A squeegee needs to be adjusted to the type of surface that it is operating on. This means the adjustments that pick up well on rough concrete will probably not work well on glass-smooth vinyl tile or ceramic tile. The reverse would hold true also, a squeegee set up for a smooth surface will not work well on rough surfaces. As a squeegee wears, the dynamics or condition of the blades change, sometimes requiring small adjustments or sometimes requiring a blade turning or change.

Our squeegee system has only one operator-serviceable adjustment. That adjustment is the thumb wheel directly in front of the squeegee blade. By turning this knob you pivot the squeegee back and forth increasing or decreasing the amount of air allowed into the squeegee under the bottom of the front blade. The basic adjustment you are trying to achieve is to have the squeegee PERFECTLY parallel with the floor. From that point, rocking the squeegee forward about one half degree of pitch will reduce air leak. Rocking the squeegee backwards about one half degree will increase the air leak.

PITCH ADJUSTMENT KNOB

The triangular shaped plate that the squeegee bolts to is adjustable for a slight amount of up/down pitch. As you turn the knob the pitch of the squeegee changes.

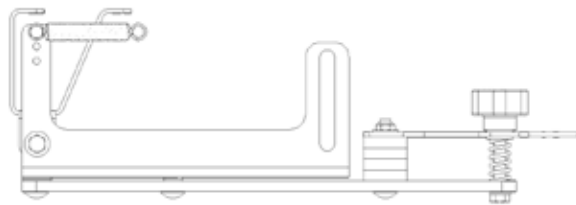

Turning the knob clockwise lowers the front blade of the squeegee thereby closing off the air holes against the floor. This increases suction on the floor. If you adjust it too far forward you can cause chattering problems, excessive front squeegee blade wear or grind the tips off both the front and rear squeegee blades.

If too much suction is created the squeegee will “chatter”, and may come off the machine. If this happens the suction must be reduced by turning the knob counterclockwise 1 to 2 turns to create more of an air leak at the front blade.

You can over adjust in either direction. The squeegee will not work if the back blade is not evenly deflected across rear, and if wheels do not touch the floor.

FIGURE 1

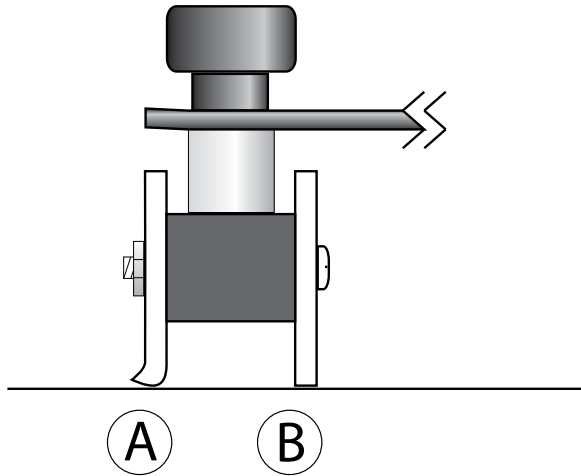

Worn Blade: Squeegee wiping edge has worn so the square edge is gone. The squeegee now runs over the water instead of scraping it off the floor.

FIGURE 2

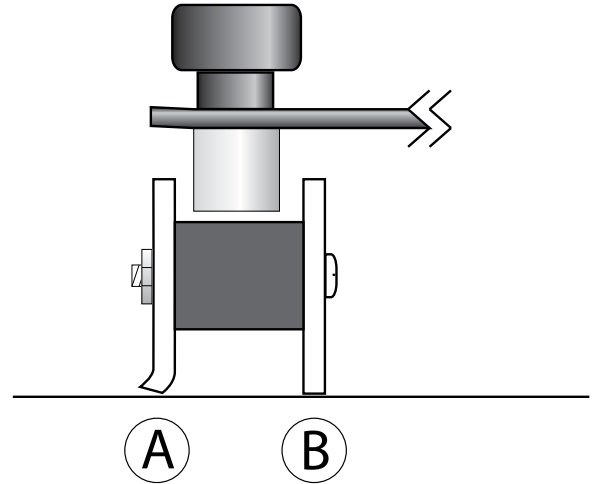

Properly Adjusted Squeegee: Front blade just contacts the floor rear blade is slightly flared outward

FIGURE 3

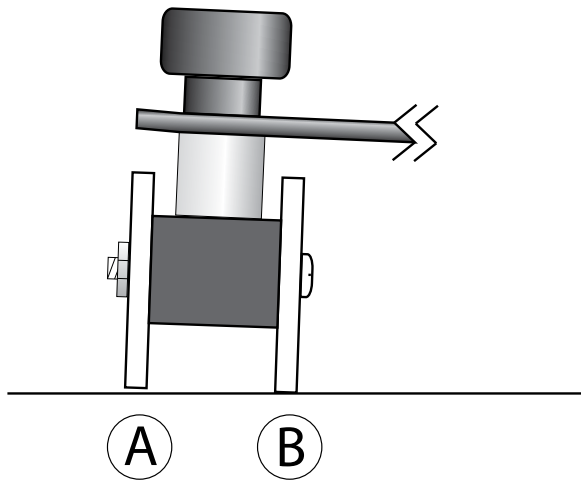

Too Much forward pitch on this squeegee. The Rear blade is barely making contact with the floor. The rear wheel are not touching the floor.

FIGURE 4

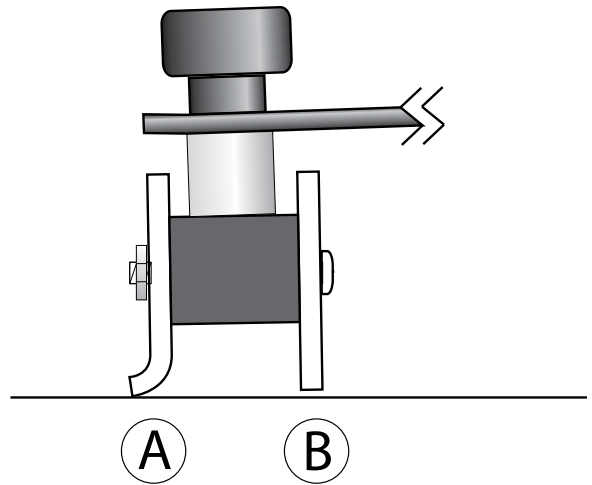

Too Much backward pitch on this squeegee. The rear blade is laying over and the front blade is not touching the floor.

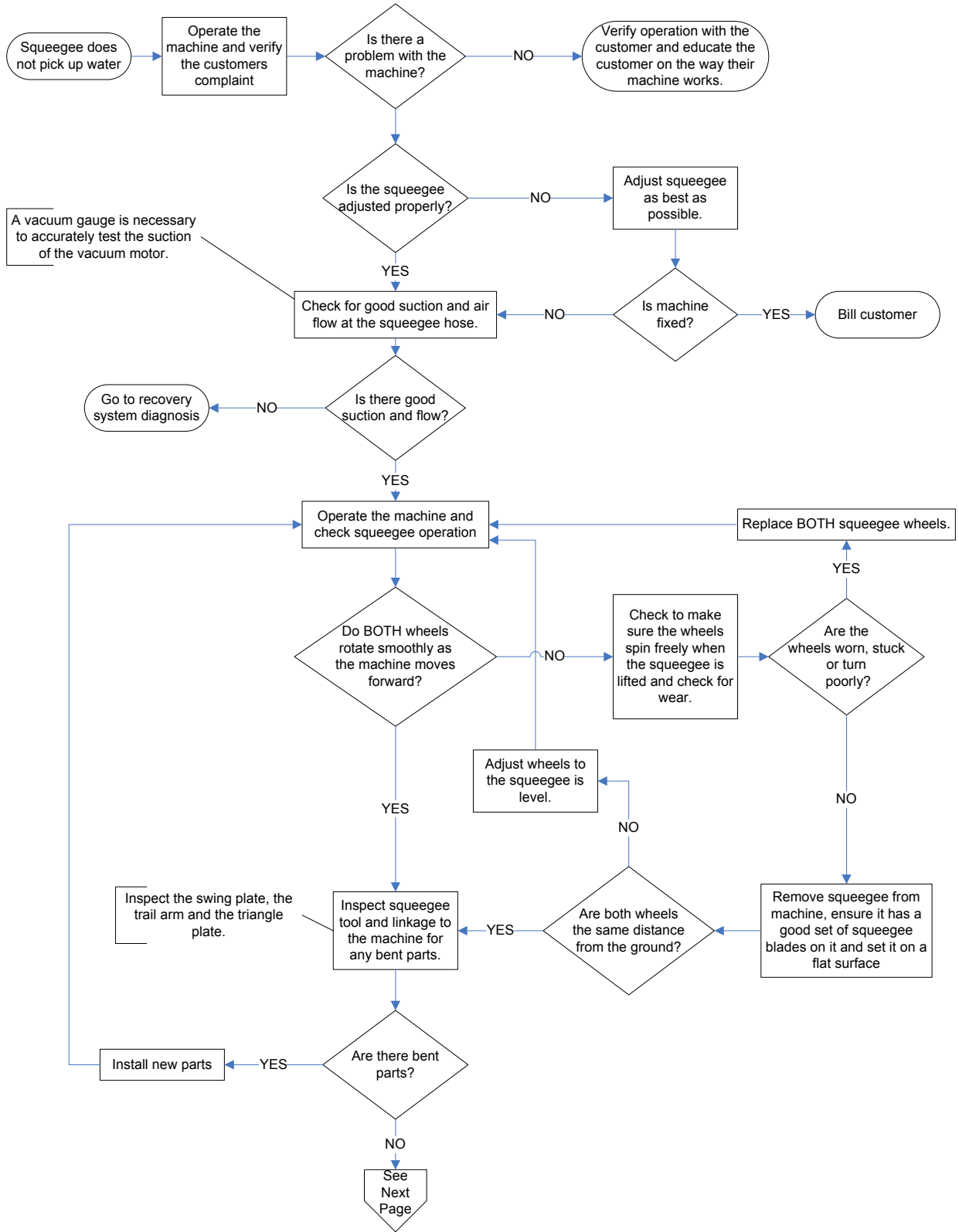

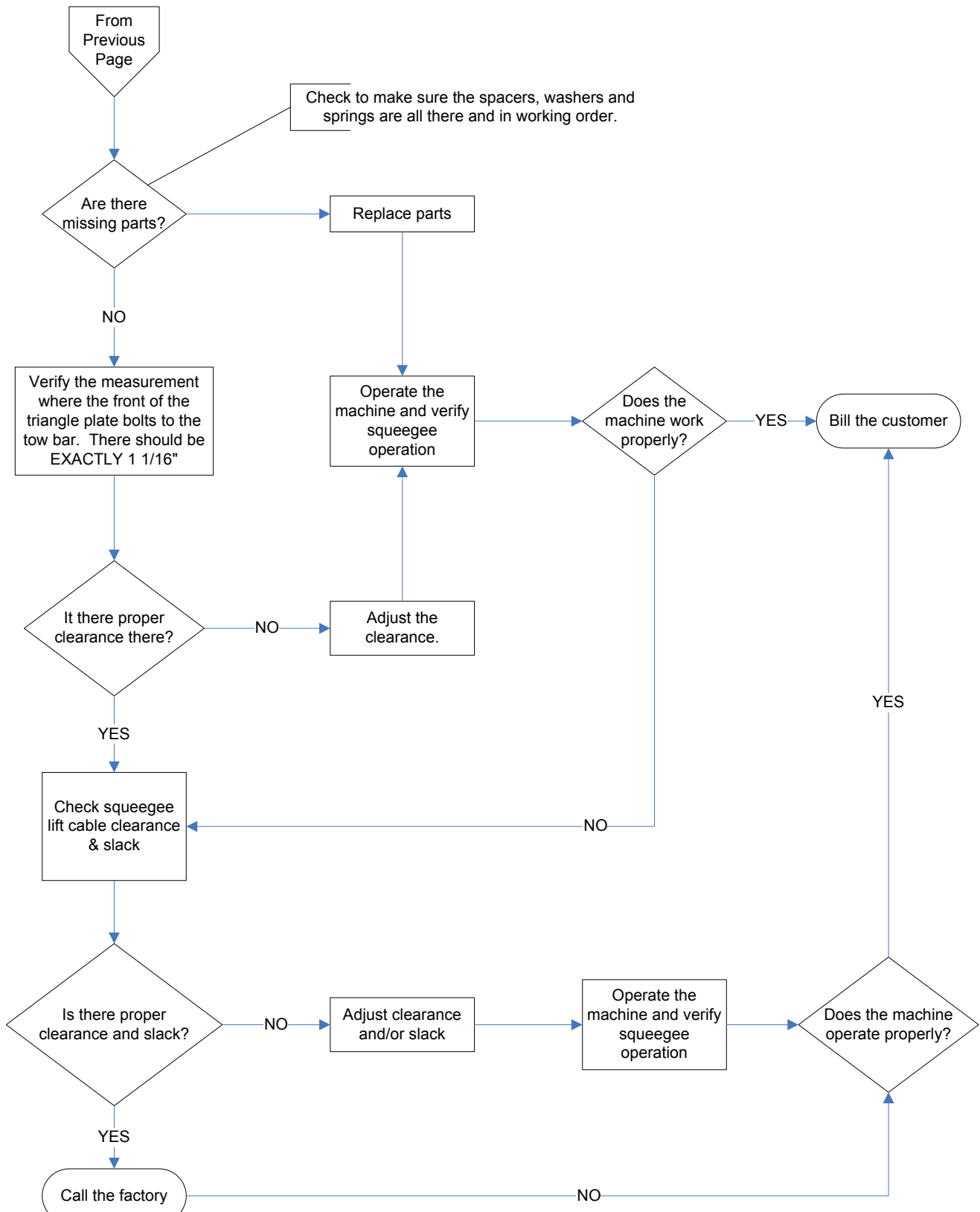

SQUEEGEE LIFT SYSTEM

The squeegee lift system is controlled by the onboard controller. The actuator is raised and lowered by the machine's controller. It raises and lowers the squeegee when the controller applies power to it. The controller receives inputs from the throttle pedal, direction switch and other dash board switches. When either the squeegee switch, the One Touch switch or the off board vac wand switch is turned on the squeegee drops when the machine is in the forward direction. The squeegee automatically raises immediately if the machine is put into reverse. When the machine is placed back into forward travel the squeegee then drops back down automatically. When the squeegee is turned off while moving forward it will stay down for a period of 10 seconds before raising to catch any water left behind by the scrub brushes. The vacuum motor will continue to run for 45 seconds after the squeegee has lifted to purge the vacuum hoses of any extra water.

SWITCH OPERATION

There are three switches on the machine that will send a signal to the controller to operate the squeegee lift system. The switches themselves do not operate the system but they send a signal to the machine controller that then operates the squeegee lift. The three switches are as follows:

SQUEEGEE SWITCH

The squeegee switch is located on the top of the central command and is the rocker switch to the left of the solution control. When this switch is turned on the squeegee will drop to the floor. When the machine is put in motion the vacuum motor will run and the squeegee will stay down unless the switch is turned off or the machine is switched into reverse. If the switch is turned off the squeegee will stay down for 10 seconds to pick up any additional water and the vacuum motor will run for 45 seconds to clear the hoses of any water. If the machine is switched into reverse the squeegee will raise immediately and remain up until the machine is switched back into forward. The vacuum motor will continue to run as long the machine is in motion.

UNI-TOUCH SWITCH

The "Uni-Touch" switch is the round green button located on the top of the central command. There are 2 styles of this switch. The first style was a lighted switch and when the switch was depressed, the on position, the switch would be illuminated. The second style, used currently, is a green button with a yellow ring around the bottom. When the switch is off the yellow ring is visible, when the switch is on, depressed, the yellow ring can not be seen. When the machine is put in motion the vacuum motor will run and the squeegee will stay down unless the switch is turned off or the machine is switched into reverse. If the switch is turned off the squeegee will stay down for 10 seconds to pick



up any additional water and the vacuum motor will run for 45 seconds to clear the hoses of any water. If the machine is switched into reverse the squeegee will raise immediately and remain up until the machine is switched back into forward. The vacuum motor will continue to run as long the machine is in motion.

OFF BOARD VACUUM SWITCH

The off board vacuum switch is located on the side of the central command near the operators left knee and is covered with a white weatherproof switch cover. The down position is “auto” and the up position is “on”. This switch is designed to be used with an off board vacuum wand attached to the machine. When this switch is turned on the vacuum motor runs continuously when the machine is turned on. The squeegee will raise when the machine is switched into reverse and drop again when the machine is switched into forward.

SQUEEGEE LIFT OPERATION

To operate the squeegee lift one of the three squeegee switches must be turned on. When one of these switches is turned on the controller sees a request for the squeegee to be lowered. The controller checks to make sure the machine is switched into forward direction and if so lowers the squeegee. The controller lowers the squeegee by sending positive and negative power in forward polarity to the squeegee actuator for a programmed length of time. The actuator will lower the squeegee and continue to run giving the squeegee slack. The actuator will stop running by the programmed run time elapsing or by reaching the end of its travel and contacting a limit switch that interrupts the power to the actuator motor. The controller watches the direction switch of the machine and the squeegee is raised immediately when the machine is switched into reverse. To raise the squeegee the controller sends power to the squeegee actuator with the polarity reversed to make the actuator run in the opposite direction. The squeegee will raise until the time that is programmed into the controller has elapsed or by reaching the end of its travel and contacting a limit switch that interrupts power to the actuator motor. When the machine is switched back into forward the controller will again drop the squeegee provided one of the 3 squeegee switches is still turned on. When the squeegee is down and all the squeegee switches are turned off the controller will no longer see a request for the squeegee. The controller will then count down a programmed time, 10 seconds, and then to raise the squeegee the controller sends power to the squeegee actuator with the polarity reversed to make the actuator run in the opposite direction. The squeegee will raise until the time that is programmed into the controller has elapsed or by reaching the end of its travel and contacting a limit switch that interrupts power to the actuator motor.

SQUEEGEE LIFT ADJUSTMENT

This squeegee lift system utilizes an actuator with integrated internal limit switches making it a very simple system to diagnose and maintain.

This system only has 1 adjustment. We control only the length that the actuator extends. The actuator retraction can not be adjusted. The purpose of the internal limit switches are to stop the actuator before it reaches the end of its travel. If the actuator reaches the end of its travel it can stall and will not be able to move again and may overload the controller producing a code 1312.

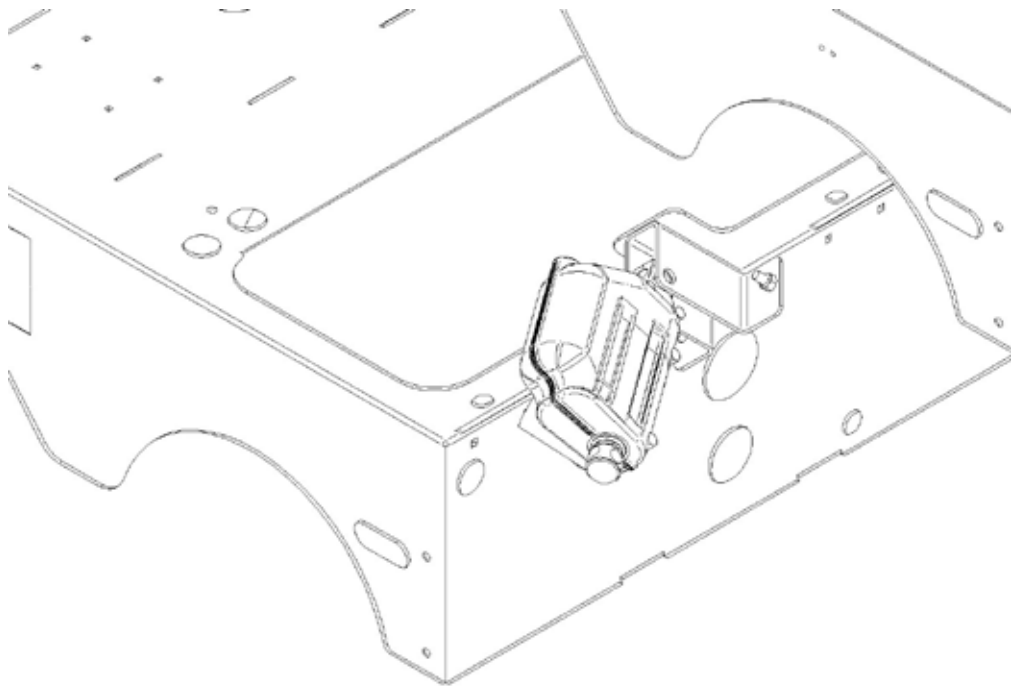

LIMIT SWITCH ADJUSTMENT

Assure the actuator is in the fully retracted position.

Remove the black rubber strip on the side of the actuator.

With a T-15 Torx driver loosen the limit switch screw and slide the switch to either increase or decrease travel. Tighten the limit switch screw.



BLANK
THIS PAGE WAS INTENTIONALLY LEFT BLANK

RECOVERY SYSTEM

The standard recovery system on the 250 & GTX series is powered by a single 1.5 HP, 36 volt 3 Stage vacuum motor. The vacuum system was designed with safety features to limit damage to vacuum motors or the recovery tank by operator error or ignorance. The machine is equipped with a visible high recovery light, an audible full recover tank alarm, Auto Vacuum shut down when tank is full, float balls and screen cage assemblies inside the recovery tank, a filter assembly to assure no debris gets into the vacuum motor, a vacuum de-misting chamber with an automatic valve so it drains each time the vacuum motors are shut down.

RECOVERY TANK LID

The recovery tank lid is made of 8 gauge #304 stainless steel. The tank is held closed with two soft latches. When the tank is opened it gives full access to the recovery tank to allow it to be completely cleaned. The tank lid has external bumpers affixed to prevent it from opening too far. The recovery tank lid is equipped with a clear dome so the operator can observe the condition of the recovery tank during operation.

DRAIN SAVER

The drain saver is located inside the recovery tank and is accessed by opening the recovery tank lid. It is designed to collect large debris that is picked up by the squeegee so it does not settle in your recovery tank or clog the drain hose or its opening.

RECOVERY TANK

The recovery tank is part of our “Monotank” design and is integral also to the solution tank. The tank is made of High Density Polyethylene and is very strong.

VACUUM FLOATS

The machine is equipped with a vacuum float. This float is in place to mechanically limit the intrusion of water into the vacuum motors. When the water reaches a certain level it raises the ball and plugs the vacuum port preventing large amounts of water from entering the motor and preventing the recovery tank from over filling.

VACUUM SAVER

The 250/GTX is equipped with a vacuum saver. This vacuum saver is a device that is attached to the face of the vacuum motor. It is a chamber equipped with an automatic drain so in the event that water would get down to the vacuum motor when the machine is turned off the water would drain out.

VACUUM MOTOR

The 250/GTX is equipped with 1 vacuum motor standard but an additional vacuum motor can be added when the machine is initially ordered.

OVERFILL / BLOCKAGE ALERT SYSTEMS

The 250/GTX series machines are equipped standard with both an audible and visual alert system to notify the operator when the recovery tank is full or the squeegee hose has a restriction.

AUDIBLE SYSTEM

The audible system alerts the operator that the recovery tank is full or the vacuum path is clogged by sounding a horn located inside the central command unit. At the same time the alarm is sounded the vacuum motor is turned off so pick up of water will be halted. The horn and vacuum motor are turned on and off continuously until the vacuum is shut off and/or the recovery tank is emptied. This system will not operate properly if the vacuum float system is not in proper working condition.

VISUAL ALERT

The visual alert alerts the operator with a red light on the top of the central command. When the recovery tank reaches it's maximum level a float switch in the tank is activated and it then turns on the light.

DRAIN HOSE

To drain the recovery tank there is a poly hose with a tethered drain plug. This hose is designed to that the operator can restrict the flow with their hand when emptying the recovery tank.

BLANK
THIS PAGE WAS INTENTIONALLY LEFT BLANK

BLANK
THIS PAGE WAS INTENTIONALLY LEFT BLANK

SOLUTION SYSTEM - GENERAL INFORMATION

The solution system begins with the “Monotank” which is an integral solution/recovery tank that eliminates both un-cleanable bladder systems and wasted space. The tank is made of high density polyethylene and can only withstand water up to 135 degrees before it will start to distort and loose its shape. The solution flows out of the tank and through a ball valve that allows you to shut off the solution to service the solution filter or solution solenoid. From the ball valve it travels through a solution filter that has a removable bowl and screen so it can be cleaned out. The solution then flows through an electric solenoid valve. This valve regulates the volume of solution being delivered to the floor. This is regulated by pulsing the valve 1 time per second. The more water that is requested the longer the pulses last. If maximum solution delivery is requested the valve receives continuous power, keeping the valve continuously open. If the solution control is adjusted to minimum the valve receives no pulses of power keeping the valve continuously closed. After passing through the solenoid the solution then exits the machine onto the floor either through 2 tubes on a disk machine or though the metering trough on the front of the cylindrical deck.

The 250 and GTX Models were produced with a 1st Design and 2nd Design solution system. The they each operate differently as follows:

SOLUTION SYSTEM - 1ST DESIGN

SOLUTION GAUGE

The solution gauge is a sight type gauge located on the front left corner of the tank near the operators left leg, between the Solution tank and the central command box. The tube has a blue float ball to aid in seeing the solution level in the tank.

DISPENSING SOLUTION

Make sure the recover tank is at least 1/2 full with desired scrubbing solution. Adjust solution output by either rotating the solution control knob or moving the solution toggle switch.. Turn on the brush deck switch. Activate the machine by depressing the foot pedal slowly. The solution will start to flow when the brushes start to turn and will stop when the brushes stop. Turn the solution control potentiometer while scrubbing to increase or decrease the solution output volume.

ADJUSTING SOLUTION FLOW

To adjust the solution flow use the solution potentiometer located on the top face of the central command. To increase the volume of solution turn the knob counter clockwise. To decrease the amount of solution turn the knob clockwise. The adjustment is infinitely variable.

DRAINING THE SOLUTION TANK

There is a ball valve located at the right rear of the machine. Simply pull the machine up to where you want to drain the solution and reach underneath the machine to turn the ball valve. When the machine is done draining or drained to your desired level close the valve.

SOLUTION SYSTEM ELECTRICAL CIRCUIT

The electrical circuit of the 250/GTX series is divided into two circuits. The input circuit and the output circuit. The input circuit consists of the controller, the scrub switch, the Uni-Touch switch, and the solution potentiometer. The controller produces a high (5 volt) and a low (0 volt) reference signal that is sent to the outside terminals of the solution potentiometer. The potentiometer then outputs a varied voltage from 0 to 5 volts. This varied voltage is sent back to the controller. The controller also sends out a 5 volt signal to both the Uni-Touch and scrub switch. When either the scrub or the Uni-Touch switch is turned on the 5 volt reference signal is sent back to the controller to a brush request input terminal. When the controller sees 5 volt signal on the brush request input and it receives a signal from the foot pedal to move the machine, it monitors the output voltage from the potentiometer to determine the length of the voltage pulse that is sent to the solution solenoid valve. The more solution requested the longer the pulse of electricity that is sent to the solution valve.

SOLUTION SYSTEM - 2ND DESIGN

SOLUTION GAUGE

The standard solution gauge is also the solution drain tube at the rear of the machine. The tube is graduated to reflect the amount of fluid in the solution tank. An optional solution gauge is available. This optional solution gauge is a sight type gauge located on the front left corner of the tank near the operators left leg, between the Solution tank and the central command box. The tube has a blue float ball to aid in seeing the solution level in the tank.

DISPENSING SOLUTION

Make sure the recover tank is at least 1/2 full with desired scrubbing solution. Adjust solution output by either rotating the solution control knob or moving the solution toggle switch.. Turn on the brush deck switch. Activate the machine by depressing the foot pedal slowly. The solution will start to flow when the brushes start to turn and will stop when the brushes stop. Turn the solution control potentiometer while scrubbing to increase or decrease the solution output volume.

ADJUSTING SOLUTION FLOW

To adjust the solution flow use the rocker switch on the top face of the central command. Rock the switch either forward or backward to increase or decrease the solution flow. This system has 6 solution output settings. The current solution output setting is reflected on the LCD display by the "Solution" bar graph

DRAINING SOLUTION TANK

The solution tank can be drained by uncoupling the solution sight tube from the barb at the top of the tank and lowering it to an appropriate drain or container.

SOLUTION SYSTEM ELECTRICAL CIRCUIT

The electrical circuit of the 250/GTX series is divided into two circuits. The input circuit and the output circuit. The input circuit consists of the controller, the scrub switch, the Uni-Touch switch, and the solution potentiometer. The solution output setting is reflected on the LCD display. There are 5 different solution setting plus OFF. The controller produces a high (5 volt) and a low (0 volt) reference signal that is sent to the top and bottom terminals of the solution switch. When the switch is pushed to increase the solution volume it sends a 5 volts reference signal through the brush pressure input of the controller increasing the solution volume each time it sees the 5 volt signal. When the switch is pushed to decrease the brush pressure it sends a 0 volts reference signal through the switch and to the solution input of the controller decreasing the solution output each time it sees the 5 volt signal. The controller also sends out a 5 volt signal to both the Uni-Touch and scrub switch. When either the scrub or the Uni-Touch switch is turned on the 5 volt reference signal is sent back to the controller to a brush request input terminal. When the controller sees 5 volt signal on the brush request input and it receives a signal from the foot pedal to move the machine, it monitors the output voltage from the potentiometer to determine the length of the voltage pulse that is sent to the solution solenoid valve. The more solution requested the longer the pulse of electricity that is sent to the solution valve.

BLANK
THIS PAGE WAS INTENTIONALLY LEFT BLANK

BRUSH DRIVE SYSTEM

The brush drive system on the 250/GTX Series comes in two versions. The disc type and the cylindrical type. Each one has its own merits although they do the same thing which is turn the scrub brush or scrub pad.

DISC

The disc brush drive system consists of the controller, 2 brush drive motors, 2 brush driver hubs and 2 scrub brushes or 2 pad holders. The drive hub is a “gimbaled” design that helps compensate for irregularities of the floor. Only original factory equipment brushes should be used on this machine or premature scrub motor failure may occur. “Will-Fit” brushes are usually not concentric and promote bearing failure”

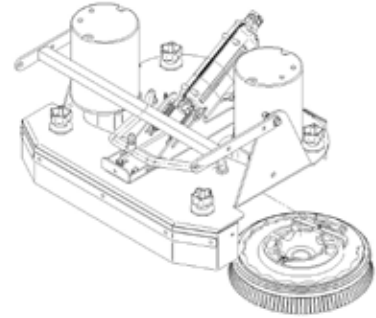

CYLINDRICAL

The cylindrical brush drive system consists of the controller, 2 brush drive motors, 2 drive belts, 2 brush idlers and two scrub brushes.

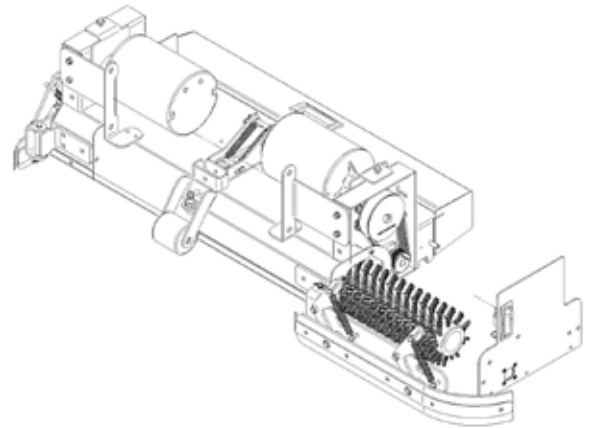

BRUSH DRIVE ELECTRICAL CIRCUIT

The brush drive circuit is very simple. A positive and negative wire run from the controller to the scrub deck. On cylindrical machines there is a protection circuit breaker wired in line to each of the motor brushes. The controller watches the amperage draw on the scrub motors and regulates the brush deck pressure to keep the motors operating at a consistent amp draw thus maintaining a consistent deck pressure. The cylindrical decks have independent motor protection on them because the motor demand can vary so greatly from one brush to the other and the controller views them as one motor.

SETTING BRUSH PRESSURE

The scrub deck pressure is adjusted continuously while scrubbing. Using the brush pressure switch on the control panel you set the desired scrubbing pressure. The desired brush pressure is shown on a bar graph on the LCD display. There are 5 different settings to choose from. The controller is programmed with an amp value for each of 5 brush pressure settings. When the scrub deck starts the controller calculates the amp draw of the motors and compares it to the amp value of the current brush pressure setting. If the motors are not drawing enough amps the controller lowers the brush deck to increase the brush pressure on the ground and therefore raise the amp draw of the motors. If the amp draw of the motors is higher than the target amp value the controller raises the brush deck to relieve down pressure from the brush deck therefor reducing the amp draw of the brush motors because they can then turn more easily.

INSTALLING & REMOVING BRUSHES

DISC MACHINES

With the machine turned on, turn off the brush deck switch. Turn machine power off and remove the key. Open the brush deck access doors on either side and swing them aside. Rotate each brush until both tabs of the spring clip are accessible. Squeeze the two tabs together and the brush will drop off. If the brush deck does not raise high enough to remove the brushes. Turn the machine power on for 10 seconds and then off again. Then try removing the brushes again. If the brushes still can not be removed due to lack of space the actuator or linkage must be adjusted.

To install a brush reverse the procedure.

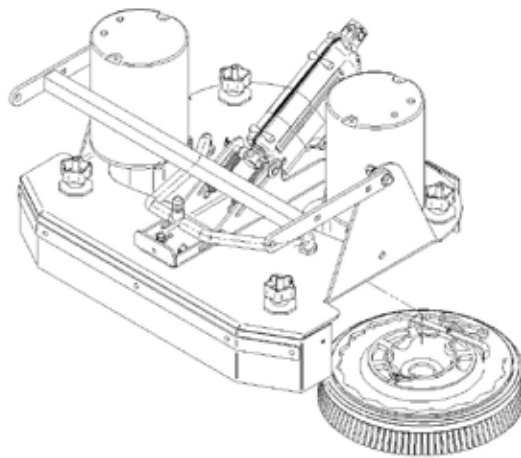

CYLINDRICAL DECK

With the brush deck raised, open the brush deck access doors on either side and swing them aside. Remove the side access door from the scrub deck. Grasp the scrub brush and pull and it will slide off the brush driver and out from under the scrub deck. To install brushes align brush with the brush drive and push until the brush slides down onto the driver. Install the access door back onto the brushes. If the access door does not fit up to the brush deck completely the brushes are not situated on the drivers properly. Realign the brushes until they slip onto the drivers completely and the access door sits tightly against the brush deck and latch will close easily.

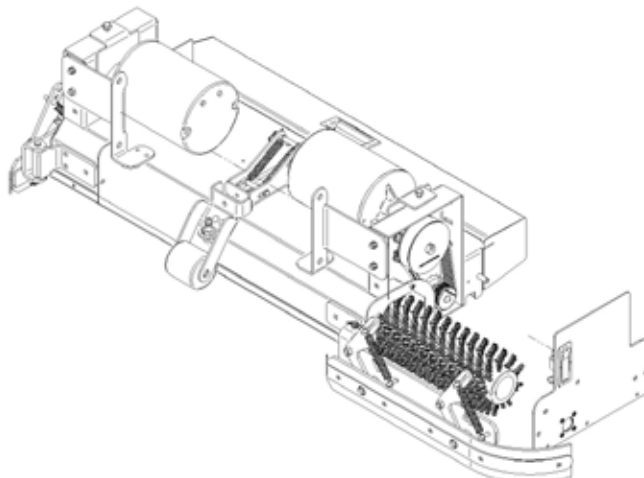

BLANK
THIS PAGE WAS INTENTIONALLY LEFT BLANK

BRUSH LIFT SYSTEM

The 250/GTX is equipped with an active brush pressure & lift system. The brush deck is lifted and lowered by the brush deck actuator. The actuator is driven by the central controller. The machines have one of two controllers in them, a V.3 or V.4. On the V.3 & V.4 controllers the actuator circuit is internally protected from electrical overload by the controller. The active brush lift system is used to lower the brush deck when scrubbing is started and raise it when stopped. Once scrubbing begins the controller continually monitors the amperage draw of the scrub brushes and raises and lowers the scrub deck accordingly to keep the motors drawing a consistent amount of amperage thus keeping the scrub pressure uniform.

The actuators are mechanically protected from over extension or retraction and overload by a clutch mechanism. In the event that an actuator reaches a mechanical stop or is overloaded it will begin to make a loud ratcheting sound. It is possible for an actuator to draw too many amps from the controller if it enters the ratchet zone and this can cause a controller fault and the controller will shut down the actuator and display a Diagnostic Code on the LCD display.

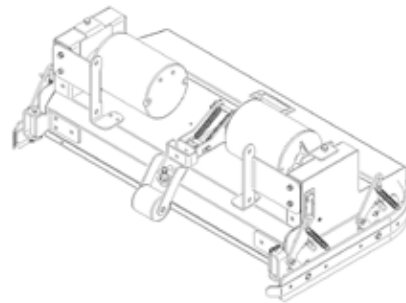
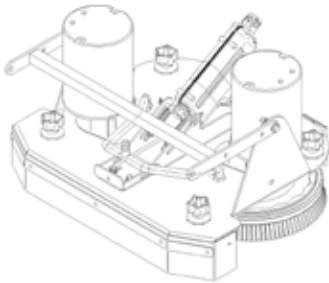

BRUSH LIFT ELECTRICAL CIRCUIT

It is important to know this circuit energizes the brush deck actuator to raise the brush deck for 4 seconds each time the controller is powered up. For this reason it is important to make sure all body parts are clear from under the scrub deck when the machine is powered on.

The brush lift electrical circuit itself is a very simple circuit. It consists of two wires that run from the controller to the actuator. Power is applied to the actuator with the polarity in one direction to raise the brush deck and the opposite direction to lower the brush deck. The actuator uses limit switches that prevent it from moving too far in either direction. On the first and second designs the limit switches were mounted externally. On the third design the actuator has internal limit switches. While the circuit itself is very simple, the control of this circuit is very complicated. The controller operates the output of this circuit by monitoring a number of variables. When the scrub switch is turned on the controller runs the scrub brushes down toward the floor for a predetermined amount of time. This is known as dock

time and can be modified by changing the parameters of the controller. When the throttle pedal is depressed the controller sends power to the actuator to control the brush pressure on the floor. When the pedal is released the controller send a power pulse to the actuator for approximately 2 seconds to raise the brushes so when they start again they do so under reduced load. When the brush deck is turned off either via the Uni-Touch switch or the brush deck switch the controller will apply power to the brush deck actuator to raise the deck to the fully raised position. The amount of time this raises for is programmable in the controller.

DOWN PRESSURE

Down pressure is regulated by the controller on the machine. The desired brush pressure is selected by using the brush pressure switch on the control panel. The brush pressure selection is read out on the LCD display in the form of a bar graph.. The bar graph is segmented in to 5 levels, the lowest being 1 bar and the highest being 5 bars. The pressure relative to each of the settings is programed into the controller and are fully adjustable. When the throttle pedal is depressed the controller sends power to the brush motors and monitors the amp draw of the motors. The controller then adjusts the scrub deck height to obtain the target amp draw on the scrub motors. The target amp draw of the motors is set using the brush pressure switch on the control panel. The brush pressure setting is shown on the LCD display in the form of a bar graph. The target amps for each of the brush pressure settings are defined by the parameters that are programed into the controller. When the throttle of the machine is released the scrub brushes raise up off the floor for 2 seconds. This is called raise time. The purpose of this is so the scrub brushes start up under reduced load which leads to much longer motor life. Raise time can be modified and is set through programing. If scrubbing begins again the brushes drop back down to the floor and the controller again starts analyzing the brush motor amp draw and adjusting the scrub deck pressure accordingly. When the scrub deck switch is turned off the scrub head raises for four seconds to it's fully raised position,

BRUSH DECK ADJUSTMENT

The brush deck raised height is adjustable by moving the bracket bolted to the top of the deck that the brush deck actuator attaches to. This bracket is slotted and can be slid forward and backward to control the ultimate lift height of the brush deck. To increase the raise height slide the bracket forward to decrease the lift height slide the bracket backwards.

ADJUSTING DECK HEIGHT

The uppermost brush deck height on the 250 / GTX machines is able to be adjusted mechanically. The mechanical adjustment has a first and second design.

FIRST DESIGN

The first design was made with a bracket that sat atop the scrub deck that was slotted. This was set at the factory and generally required no adjustment but in the even the scrub deck encountered an impact with a substantial object the adjustment would slip to prevent damage to the scrub deck. In order to re adjust the scrub deck The deck was to be lowered and then the key turned off and the battery disconnected. The deck should then be raised with a jack or by blocks to relieve all weight from the brush deck actuator. Once the weight is released the bracket that attached the actuator to the scrub deck should be loosened. The bracket should then be slid all the way backwards on the deck until it can no longer move and then retightened, Re connect the battery and turn the machine on. The deck will now raise to it's higher point.

SECOND DESIGN

The second design of the scrub deck height adjustment was created with a heavy duty bracket and a tensioner bolt to hold the adjustment on the deck In order to re adjust the scrub deck The deck was to be lowered and then the key turned off and the battery disconnected. The deck should then be raised with a jack or by blocks to relieve all weight from the brush deck actuator. Once the weight is released the bracket that attached the actuator

BLANK
THIS PAGE WAS INTENTIONALLY LEFT BLANK

TRACTION DRIVE SYSTEM

The 250/GTX series of machines are powered by a powered drive wheel. The motor, gears and housing are all in one package. In the event of a machine failure the machine should never be towed without first disconnecting the front drive and then releasing the parking brake manually. Failure to do this will cause the controller to fail.

There have been 3 styles of drives used on the 250/GTX machines. They are very easy to identify.

GEAR RESEARCH - 1st Design

This drive has a black or grey tire, a lever for releasing the parking brake and an aluminum casting. It is easy to differentiate from the 2nd design by the lack of wheel bolts. The wheels on these drives are pressed on and can not be replaced. In the event of a tire failure the entire drive must be replaced.

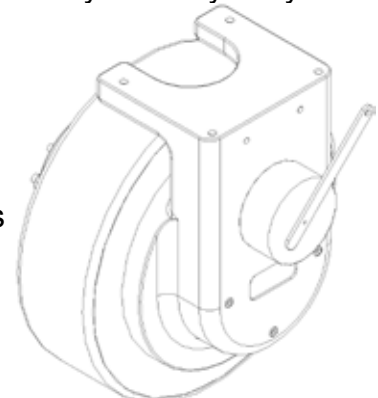

GEAR RESEARCH

Gear Research - 2nd Design

This drive has a Black, Grey or Poly tire and looks similar to the 1st design. It is easy to differentiate as it has bolts around the drive tire that can be removed to replace the tire. The 2nd design also has a dust cap over the parking brake and the parking brake is now lower on the drive so it grabs the motor shaft giving it more holding power.

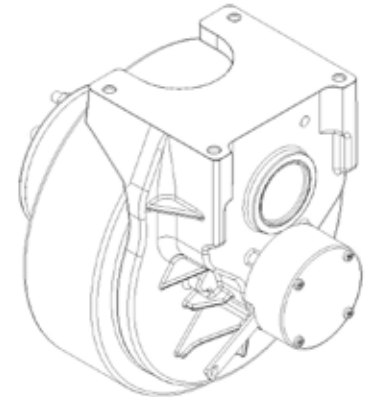

GEAR RESEARCH

METAL ROTA

This drive has a purple tire, a wing nut for the parking brake release and a black steel casting.

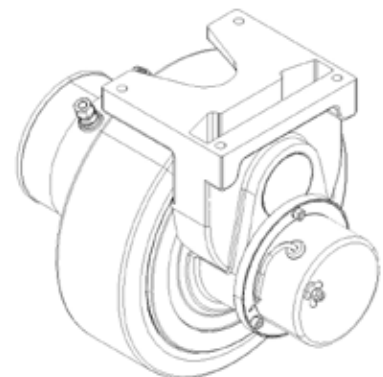

METALROTA

TRACTION DRIVE ELECTRICAL CIRCUIT

The traction drive electrical circuit consists of the traction drive motor, controller, foot pedal and the reverse switch. When you depress the foot pedal it sends a signal to the controller and the controller then energizes the parking brake and releasing it while sending power to the traction motor propelling the machine. When the reverse switch is engaged it sends a signal to the controller to move the machine backwards when the foot pedal is depressed. The controller then energizes the drive motor to propel the machine in reverse. Both the forward and reverse speeds are regulated by the potentiometer located in the foot pedal. The controller has internal protection for the drive motor to prevent it from climbing too steep of hill or pushing anything. It will slow the machine down if the traction motor draws too many amps for more than 60 seconds. If the overload continues the controller will shut off the motor and show a diagnostic code on the LCD display. The motor can be damaged if repeatedly overloaded in a short time. The average amp draw for transport is 7-9 amps at full speed with all other functions off.

DRIVE MOTOR

GEAR RESEARCH 1st Design

The drive motor is a separately serviced part and is easily replaced. The front tire assembly is pressed on and not serviced separately. The entire drive must be replaced if the front wheel fails. The parking brake can be replaced on this drive.

GEAR RESEARCH 2nd Design

The drive motor is a separately serviced part and easily replaced on this drive.

METAL ROTA

The drive motor is not a serviceable part on the Metal Rota drives. In the event of a drive motor failure the entire drive needs to be replaced. The front wheel can be replaced.

TIRES & WHEELS

The 3 different tires are made of a proprietary compound to aid in traction on wet slippery surfaces as well as be durable and hold up to abrasion and rough surfaces.

The black rubber tires are not serviceable and in the event of a tire failure the entire drive must be replaced.

The purple colored polyurethane tires can be changed in the event of just a tire failure.

PARKING BRAKE

All machines are to be parked on a hard level surface when an operator is not on them. The parking brakes on all our machines are to prevent them from rolling on a hard level surface in the event that someone leans up against it. The parking brakes are not designed to prevent the machine from rolling on any incline.

CHASSIS DRIVE 10 - 1st Design

The parking brake is connected to the secondary gear inside the transmission. When it is energized it releases and when de-energized it holds. To manually release the parking brake there is a lever that you pull that will release the parking brake until it is pushed back.

CHASSIS DRIVE 10 - 2nd Design

The parking brake is connected to the end of the motor shaft giving more holding power to the brake. When it is energized it releases and when de-energized it holds. To manually release the parking brake there is a lever that you pull that will release the parking brake until it is pushed back.

Metal Rota

The parking brake is connected to the end of the motor shaft. When it is energized it releases and when it is de-energized it holds. To manually release the parking brake there is a wing nut on the side of the parking brake. You tighten the wing nut firmly until it will not turn anymore. (Do not use a tool to accomplish this.)

As of this publication there are no longer parking brakes available for Metal Rota Drives. The parts have been discontinued.

BLANK
THIS PAGE WAS INTENTIONALLY LEFT BLANK

CHASSIS SYSTEM

The 250/GTX series of machines are built on a heavy duty 7 gauge steel chassis.

REAR AXLE

The rear axle of the machine is rated to carry 6,000 lbs. This is far more than the 1,000 lbs of total weight of a machine with an industrial battery. The axle is equipped with grease fittings on the dust caps to facilitate lubricating the rear bearings.

REAR TIRES

The rear tires of the machine are made of heavy duty welded steel rims. The tire is molded directly onto the rim. The tire can not be serviced by a tire press. The entire wheel assembly must be replaced in the event of failure.

REAR BUMPER

The rear bumper is an option on the machines. It is designed to protect the squeegee system from being damaged while maneuvering the machine.

SIDE BROOMS

The 250/GTX machines have optional side brooms. The side brooms increase the overall sweeping width of the machine by 8". The brooms also allow the floor to be swept up to the wall. The brooms are operated by a yellow toggle switch located by the operators left knee. When the switch is down it is in the off position. When the switch is turned on the brooms will drop to the floor and start to rotate. When the switch is turned off the brooms will stop turning and raise.

BLANK
THIS PAGE WAS INTENTIONALLY LEFT BLANK

BATTERY SAFETY

DANGER OF EXPLODING BATTERIES

Batteries contain sulfuric acid and produce explosive mixtures of hydrogen and oxygen. Because self-discharge action generates hydrogen gas even when the battery is not in operation. Make sure batteries are stored and worked on in a well ventilated area. ALWAYS wear ANSI Z87.1 (U.S. Standard) approved safety glasses and face shield or splash proof goggles when working on or near batteries.

Always wear proper face, eye and hand protection.

Keep all sparks, flames and forms of combustion away from the battery.

Never try to open a battery with non-removeable vents.

Keep removable vents tight and level except when servicing electrolyte.

Make sure work area is well ventilated.

Never lean over battery while boosting, testing or charging.

Exercise caution when working with metallic tools or conductors to prevent short circuits and sparks.

SAFE CHARGING

Never attempt to charge a battery without first reviewing the instructions for the charger being used. In addition to the manufacturer's instructions, these general precautions should be followed:

Always wear proper eye, face and hand protection.

Always charge batteries in a well ventilated area.

Keep vents tight and level.

Turn the charger and timer "OFF" before connecting the leads to the battery to avoid dangerous sparks.

Never try to charge a visibly damaged or frozen battery.

Connect the charger leads to the battery; red positive (+) lead to the positive(+) terminal and black negative(-) lead to the negative (-) terminal. If the charger is equipped with a quick disconnect plug use that to connect it to the machine.

Make sure that the machine and all its accessories are turned off.

Make sure that the charger leads to the battery are not broken, frayed or loose.

Set the timer, turn the charger on and slowly increase the charging rate until the desired charging rate is reached.

If the battery becomes hot, or if violent gassing or spewing of electrolyte occurs reduce the charging rate or turn off the charger temporarily.

Always turn the charger "OFF" or unplug it from the AC power before removing the charger leads from the battery or disconnecting the quick disconnect plug to avoid dangerous sparks.

HANDLING BATTERY ACID

Battery acid, or electrolyte, is a solution of sulfuric acid and water that can destroy clothing and burn the skin. Use extreme caution when handling electrolyte and keep an acid neutralizing solution - such as baking soda or house hold ammonia mixed with water - readily available. When handling batteries:

Always wear proper eye, face and hand protection.

If the electrolyte is splashed into an eye, immediately force the eye open and flood it with clean, cool water for at least 15 minutes. Get prompt medical attention.

If electrolyte is taken internally, drink large quantities of water or milk. DO NOT induce vomiting. GET IMMEDIATE MEDICAL ATTENTION.

Neutralize with baking soda any electrolyte that spills on a machine or in a work area. After neutralizing, rinse contaminated area clean with water.

WATER

When servicing batteries the recommended water to use is distilled water when adding it to the electrolyte. However, any water that is safe to drink, with the exception of mineral or flavored waters, is safe to use in a battery. Do not use water with a high mineral content. Avoid using metal containers to store acid or water. The metal impurities in the water will diminish the performance of the battery. Liquids besides water such as vinegar, anti-freeze, salt water and alcohol or harmful acids such as nitric, hydrochloric or acetic will cause severe grid damage and completely ruin a battery.

BATTERY TERMINAL TYPES

Batteries are made with an assortment of different battery terminal configurations. The most common in the industry are listed here. It is best to replace batteries with the exact type of battery that was in the machine including the battery terminal type. If you change battery terminal types the battery cables must be changed to match the new style terminals..

TAPERED TOP TERMINAL (S.A.E. POST)

The tapered top design uses terminal posts built to SAE standards so that all SAE style clamps will fit any battery with these posts. The negative terminal is made slightly smaller than the positive to reduce the possibility of hooking up a battery in reverse.

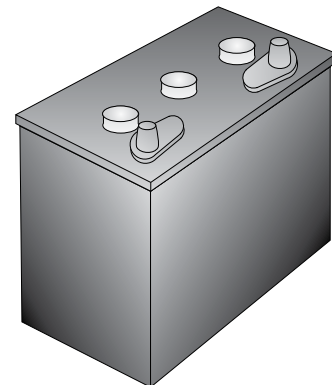

STUD TERMINAL

The stud terminal is typically used on heavy duty batteries. The terminals have a stainless steel threaded stud embedded in them that the connections are made to.

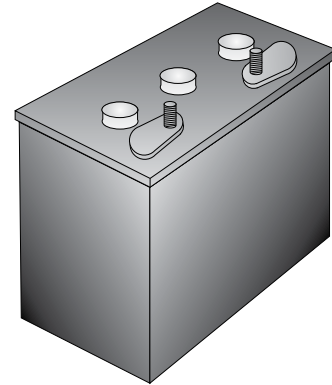

COMBINATION TERMINAL

The combination terminals come in a few different configurations. The two most common configurations are the “side by side” and the stacked. In the side by side there is a tapered top terminal with a stud terminal right next to it. In the stacked configuration the stainless steel stud is embedded into the taper top terminal. The combination terminals make it possible to use the battery with a variety of equipment without having to change the cables on it. CAUTION: The “stacked type” combination battery terminals are very tall in comparison to all other configurations. Make sure to check all clearances before trying to close a cover or a tank on top of these types of batteries.

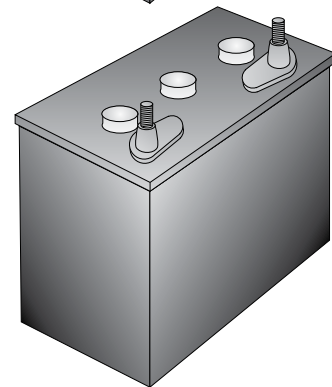
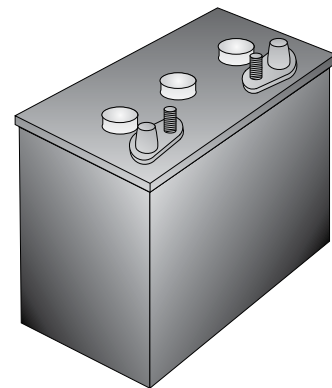

THE “L” TERMINAL

The “L” type terminal is used on many special application batteries.

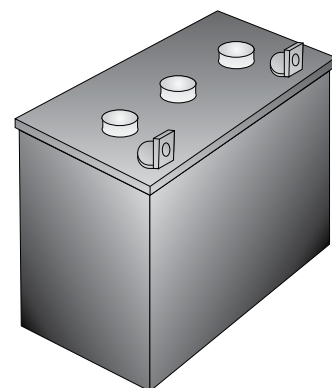

BATTERY SYSTEM

The battery system for the Magnum series consists of either 2 - 12 volt or 4 -6 volt deep cycle batteries. They are offered in 3 different sizes of lead acid and 2 sizes of maintenance free gel battery for each machine. The batteries are the power source for all of the working parts of the machine and must be maintained properly to realize optimal run time as well as longevity.

Deep cycle batteries provide large storage capacity of the electricity that powers the scrubber. There are two types of batteries that we use in our scrubber and each one has different needs to keep it performing optimally.

BATTERY MAINTENANCE & CARE

LEAD ACID BATTERIES (TRADITIONAL)

Lead Acid Batteries are the most common battery installed in our machines. They are filled with water and battery acid and require periodic care. The most important item to attend to is the battery water level. This must be checked on a weekly basis because if the batteries run low on water they will be ruined. Batteries should be checked before you charge them to make sure they have enough water to cover the plates inside them. In the event that the water is below the tops of the plates water should be added to bring the level just above the top of the plates. When adding water ALWAYS use distilled water. Tap water contains things like minerals and chlorine that is detrimental to a battery. Batteries should be charged each time the machine is used for any significant time. Batteries should never be discharged more than 80% of their capacity. The battery gauge is to alert you when it is time to stop using the machine and recharge it. The tops of the batteries must be kept clean and dry or they will induce a current leak across the top of the battery.

LEAD ACID BATTERIES (MAINTENANCE FREE)

Some of our machines are equipped with 'Maintenance free' lead acid batteries. The major difference between these and the "traditional" type of lead acid battery is that you can not check or fill the water in them.

GEL CELL BATTERIES

Gel Cell batteries are a maintenance free battery design that has no liquid to spill out in the event that a machine would be tipped over or some other disaster were to occur. The batteries perform well but not as well as a "traditional" flooded wet cell. With gel cell batteries there is no water level to check so there is less maintenance involved. With gel batteries the machine should be charged anytime it is used for any significant length of time. Gel cell batteries should never be discharged below 60% of their capacity, 21 volts on this machine, or it will cause rapid failure of the battery.

BATTERY CABLES & TERMINALS

The battery cable connections must remain tight and corrosion free. In the event that the battery cables or terminals become corroded follow accepted battery safety precautions, disassemble and clean the terminals with a baking soda and water solution and a wire brush, making sure not to get any INSIDE the battery. Once the terminals and cables are clean and dry, inspect them thoroughly for any damage or signs of arcing or over-heating. Replace and damaged cables, terminals or batteries. Reassemble the cables and batteries and coat terminals and connections with a battery terminal protectant.

IMPORTANT NOTE! Make sure to apply the protectant AFTER the batteries and cables are reassembled and tightened. Putting protectant on before assembly and tightening can lead to a fire.

BATTERY TESTING

As a battery pack ages, the batteries will slowly lose their ability to accept and hold a charge. This will usually be noticed by a decrease in run time of the machine. Neglected batteries will “wear out” much faster than well-maintained batteries but give you similar symptoms when they do fail. The proper way to check a battery pack’s condition is with a battery discharge unit. To use the discharge unit make sure the batteries are maintained properly and fully charged. Attach the discharge unit to the machine’s battery pack and turn the machine on. Record your results and compare them to your battery’s rated capacity. This will let you know how much capacity your battery pack has left. If you find through the battery discharge meter that you have reduced capacity you can test each individual battery to find out if you have one bad battery or multiple bad batteries. To test each battery you have 2 options, a hydrometer test or a load test.

Hydrometer test:

Use a hydrometer on each cell in the battery pack to check its specific gravity.

HYDROMETERS

There are 3 types of hydrometers typically available. We do not recommend the floating ball type as they are not very accurate and give minimal information regarding the batteries condition. The traditional “float type” hydrometer and the “EZ Red” or dial type hydrometer give a numeric reading of each battery cell’s state of charge.

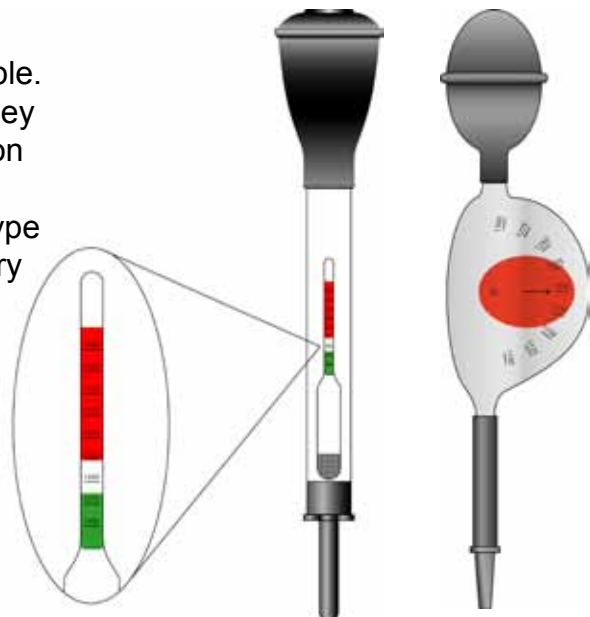

The state-of-charge of a lead acid battery can be determined by the specific gravity of the electrolyte (its weight compared to water). The specific gravity can be measured directly with a hydrometer or determined by the stabilizing voltage.

A hydrometer is a bulb-type syringe which will extract electrolyte from a cell. A glass float or a plastic disk in the hydrometer body is calibrated to read in terms of specific gravity. A common range of specific gravity used on these floats is 1.160 to 1.325. Do not assume a battery will not take a charge because you have been charging it for a while and the float will not rise. The battery may have been fully discharged and will require considerable charging time before reaching the minimum specific gravity on the float.

The lower the float sinks in the electrolyte, the lower its specific gravity. The proper way to read a hydrometer is to draw electrolyte into the body of the hydrometer while holding it vertically so the float is not rubbing on the side of it. Draw an amount of acid into the body so that with the bulb fully expended, the float will be lifted free not touching either side, the top or the bottom. Your eye should be level with the surface of the liquid in the hydrometer body. Disregard the curvature of the liquid where the surface rises against the float stem and the barrel due to surface tension. Keep your hydrometer and its float clean. Check them frequently for cracks.

The following table illustrates typical specific gravity values for a cell in various stages of charge with corresponding voltage readings.

OPEN CIRCUIT VOLTS	STATE OF CHARGE	HYDROMETER READING
12.65	100%	1.260 or more
12.45	75%	1.225 - 1.260
12.24	50%	1.190 - 1.225
12.06	25%	1.120 - 1.190
11.89	Totally Discharged	1.120 or less

When testing with a load tester you are looking for a difference between cells of the batteries. All the battery cells should have similar readings. Any battery that contains a cell that has a value lower than .050 of the rest of the cells indicates you have a bad battery.

Load test with a load tester:

Make sure batteries are fully charged. Disconnect batteries from the machine and each other so each battery can be tested individually. Using a battery load tester test each battery at either the fixed load of the tester or a 120 amp load on a variable tester. The batteries should be able to maintain a voltage of 10.8 volts or greater for 15 seconds on 12 volt batteries and 4.9 volts or greater for 15 seconds on a 6 volt battery. If they can not maintain their voltage while under load they are bad.



Load test using machine systems as a load:

Using a volt meter measure the voltage of each battery while the machine is under full load (all systems operating). If any battery shows a voltage of less than 80% of the battery with the highest voltage that battery is bad.

BATTERY REPLACEMENT

When replacing batteries in a machine it is important to replace them with quality batteries that are designed for high-output deep-cycle applications, such as the ones furnished by the factory when the machine was new. All batteries are NOT created equal. In the event you are considering other manufactures batteries make sure to compare their 75 AMP RESERVE CAPACITY. That is the ONLY specification that corresponds to the usage the batteries will be seeing.

When a battery fails in the first 12 months of operation replacing a single battery may be acceptable if the failure was caused do to manufacturing defect. If the battery pack is older than 12 months or the battery has failed due to neglect the entire battery pack should be replaced as the batteries operate as a system.

When replacing batteries it is important to neutralize any battery acid that is in or on the machine after battery removal. Clean and dry the machine after neutralization and removal of any acid. The batteries should be installed in a clean and dry machine.

When installing batteries a terminal protectant should be used to help inhibit battery terminal corrosion. It is important to use a product specifically designed for this and not things like grease, silicone or paint. Read and follow the directions on the can of protectant exactly to prevent terminal or cable failure.

BATTERY CHARGERS

There have been 5 different chargers available for the 250/GTX series machines. We offer an off-board charger standard with the machine and a high output off board charger and 3 different on-board charger have been available as options.

OFF-BOARD CHARGER

The standard charger supplied with the 250/GTX series is a fully automatic charger. To operate the charger all that needs to be done is plug it into the machines charger port and then plug it into the wall. Once the charger is plugged into both the charger port on the machine and a wall outlet it will run until the batteries are fully charged and then shut off. It is important to let the charger finish its charge cycle before disconnecting it as the last few hours of a charge cycle are very important.

The charger has an amp meter on the face of it to show how much electricity is being put into the batteries and it gives some idea of where the charger is in its cycle. Typically on a good set of batteries when you plug in the charger and it turns on, the meter will move rapidly to the high end of the amp scale. As the charge cycle progresses, the meter will fall towards zero. The charger shuts off automatically when the cycle is complete, this is evident by it not humming anymore.

ON BOARD CHARGERS

There have been 3 different On-Board chargers available with the 250/GTX series.

Version 1

This was the first on board charger offered on the 250/GX machines and was sold almost exclusively to Wal-Mart and Sam's Clubs although some were sent through typical dealer channels. This was linear wound 36V 30A charger that was mounted on the left front bottom of the machine frame under the central command. These units had a pigtail cord that came out the front of the machine. These units worked quite well but were susceptible to people using long small gauge extension cords with them which adversely affected the charge cycle.

Version 2

This was a high frequency Mosfet on board charger and it was mounted under the mono tank in the lower compartment of the 250/GTX machines. This was very efficient charger. Unfortunately we saw too many instances of end users flooding the chargers with hoses and we discontinued usage of these.

Version 3

This is the current version of the on-board charger we are using on the 250/GTX machines. This is a fully sealed charger and can withstand dripping and lowpressure water spray.

ELECTRICAL SYSTEM

The electrical system on the 390/420 series is a 36 volt DC system. This is not a chassis ground system for safety reasons.

BATTERY SYSTEM

The Model 390/420 is available with 3 battery options. Please see the “Battery System” section for more information.

SWITCHES

Most switches we use have a similar face to others on the machine but are configured differently internally. Majority of them interface directly with the machine controller and carry low voltage signals. It is important to note that when diagnosing these machines, NEVER jump battery power to the switches to test them as the controller can be instantaneously destroyed.

RELAYS

The 390/420 series uses a Hella relay to power the buss bars and isolate them from the controller. There are also relays internally mounted in the controller but these are not serviceable.

The relay we use is a 24V 15A Hella relay. This relay is energized by the key switch and is used to send power the buss bars.

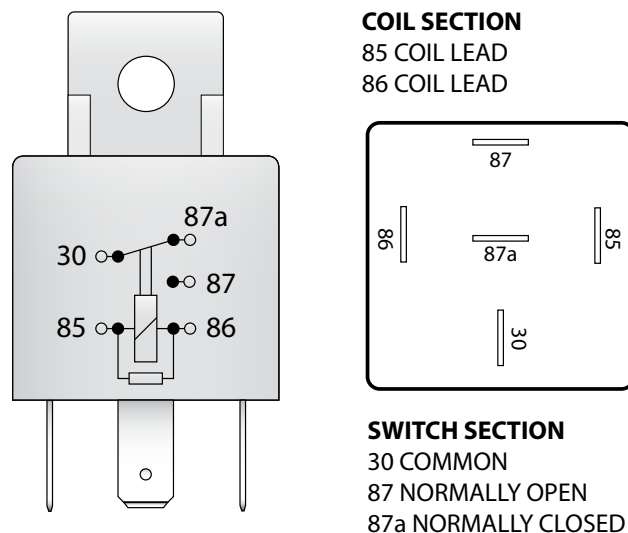

CONTACTORS

Contactors are sometimes referred to as solenoids. They are just very large relays capable of handling high amperage. On later 390/420 models we use a 200 amp contactor to isolate the drive motor from the controller. We do this so in the event the machine is pushed by another vehicle the controller is not damaged. When the key is off on the machine the controller is connected. When the key is turned on the contactor engages and connects the drive motor to the controller.

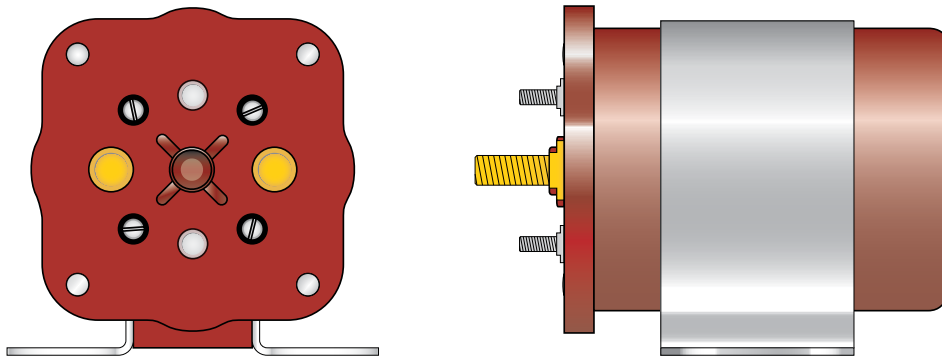

MOTORS

The motors that are used through out the machine are designed to be very durable and give long service life.

BRUSH DECK MOTORS

The brush deck motors are DC permanent magnet gear reduction type, they output large amounts of power for scrubbing. The motor brushes are replaceable and are rated to give up 2000 hours of service life depending on usage and environment. See the “Brush Drive System” chapter 7 for more information.

VACUUM MOTORS

The vacuum motors used on the 390/420 series are a 1.5 horse power motors. They are an AC motor that is driven by an integral speed controller. This is a brushless motor and therefore is significantly more durable than a standard vacuum motor. The motors are equipped with an integrated speed controller that runs them at a consistent speed regardless of battery condition or demand while at the same time saving power. Due to the integral speed control these motors have unconventional wiring to them. There are four wires that come out of the motor. There are 2 heavy 10 gauge wires, red and black and two light 18 gauge wires, orange and yellow. The two 10 gauge wires are the unswitched power into the motor. This feeds the speed controller. The Small wires are for the speed controller control circuit. The orange control wire gets wired to the negative black 10 gauge wire and the small yellow control wire is where the input signal from the main machine controller is received.

ACTUATORS

The 390/420 series uses two or three actuators depending on how it is equipped. The first is the brush deck actuator. See the “Brush Lift Section” Chapter 8 for more information. The second is the squeegee lift actuator. See the “Squeegee Lift” section for more information. The third is the side broom actuator. See the “Chassis” section for more information.

WIRING

The wiring on the machine is numbered for easy circuit determination and to be easy to trace. We over size our wiring to eliminate failures and for safety reasons.

We use a number of different wire terminals on our machines and some require special tools to properly service or replace them.

STANDARD CRIMP ON TERMINALS

The standard crimp on terminals we use on our equipment should be crimped with a positive stop ratchet type crimpers. The correct color coded terminal must be installed on the wiring system for the machine to operate safely and properly with its original integrity. It is important to use ratchet style crimpers, intended for the terminals being crimped, to assure the connector is installed properly. The ratchet style crimpers regulates the crimp so it is not too tight or too loose. Using standard pliers style crimping tools does not assure a consistent connection.

MOLEX CONNECTORS

Molex Mini Fit Jr. wire terminals are used where the wiring harness plugs into the controller and the LCD display. These terminals require a special removal tool. If an attempt to remove them is made without the removal tool it is very likely that the terminal and perhaps the connector will be damaged and need to be replaced. To replace a Molex Mini Fit Jr. terminal a special set of Molex brand crimpers is required to achieve an acceptable crimp.

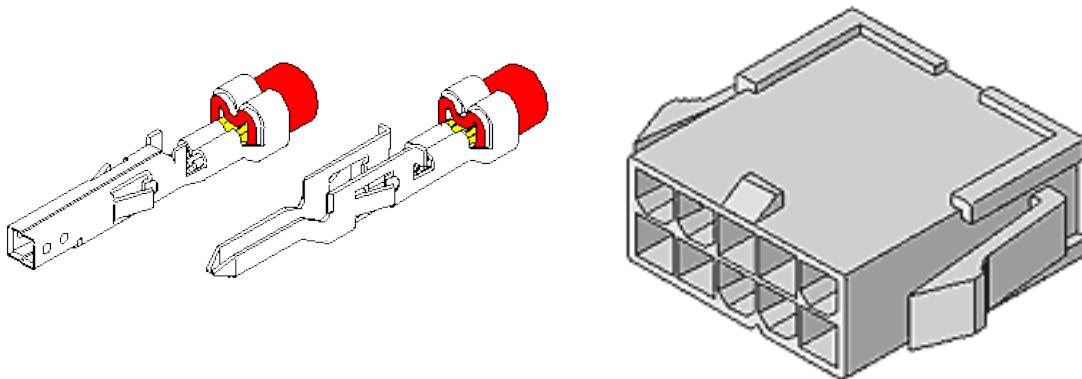



REMOVAL TOOL



MOLEX MINI-FIT JR. CRIMPING TOOL

CONTROLLER HIGH AMP OUTPUT TERMINALS

(Brush, Vacuum, Traction)

The controller high amp output connectors are crimped with a special crimping tool at the factory. The tool is not practical to use in the field so in the event that a new terminal is needed a wire end kit is available that is field installable. This kit is available through the parts department.

ANDERSON BATTERY CONNECTORS

Anderson connectors are crimped by a hydraulic crimping machine at the factory. This is not practical in the field. We recommend using a manual staking tool and then soldering the terminal to assure a good solid connection.

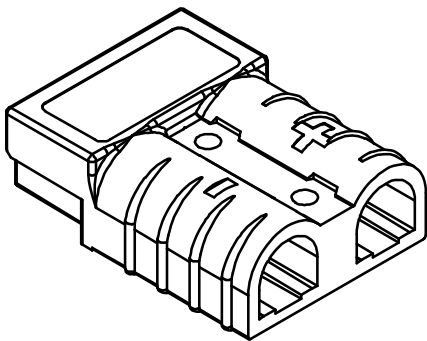
ANDERSON
CONNECTORANDERSON
CONTACTMANUAL
STAKING TOOL

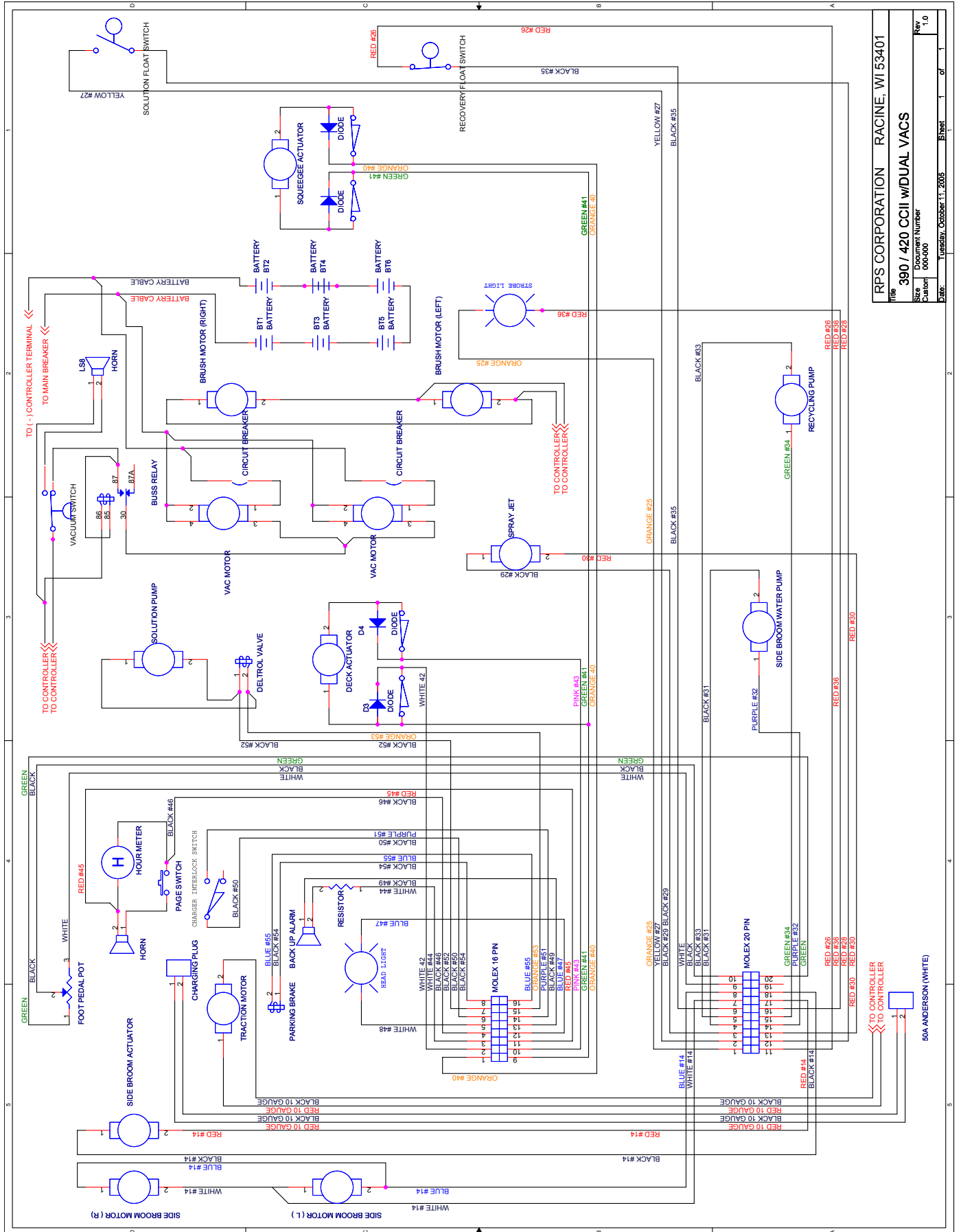

File	RPS CORPORATION RACINE, WI 53401
Size	390 / 420 CCI w/DUAL VACS
Doc#	Document Number
Customer	000-000
Date	Tuesday, October 11, 2005
Sheet	1 of 1
Rev	1.0

Wire Number	Terminal or Pin #	Component
1-19 Battery Cables		
1		Main + cable to the battery pack #1
2		Cable from 1st to 2nd battery
3		Cable from 2nd to 3rd battery
4		Cable from 3rd to 4th battery
5		Cable from 4th to 5th battery
6		Cable from 5th to 6th battery
7		Main - cable to the battery pack #1
8		Main + cable to the battery pack #2
9		Main - cable to the battery pack #2
10		Rapid Charge #1
11		Rapid Charge #2
12		Rapid Charge #3
13		Rapid Charge #4
20-39 Main Power		
20	- Buss	General 16 Gauge ground
23		General 16 Gauge (+) Positive
26		Pos (+) Battery Power to Key or Master switch
27		Power from main or key switch to main relay
28		Battery (+) to hella relay Pin 30
29		(-) battery to (-) buss breaker in
30		(+) Pin #87 on hella relay to (+) buss breaker in
31		(-) Pin #85 to (-) breaker out
32		(+) Buss breaker out
33		(-) Buss breaker out
40-59 Drive System		
50		Drive motor + 1
51		Drive motor - 1
52		Drive Motor + 2
53		Drive Motor - 2
54		Parking brake +
55		Parking brake -

60-79	Solution System
65	Low solution output from switch
66	Low solution power to switch
67	Solution Pump Power Controlled (390 420 430)
68	Solution Pump Negative (390 420 430)
70	Supply voltage to switch (Non electronic controller machines only)
71	Deltrol valve + power
72	Deltrol valve - switched power

80-119	Vacuum System
85	Vac Motor #1+
86	Vac motor #1 -
87	Vac motor #2 +
88	Vac motor #2 -
89	Vac Motor #1+
90	Vac motor #1 -
91	Vac motor #1 Control +
92	Vac motor #1 Control -
93	Vac motor #2 +
94	Vac motor #2 -
95	Vac motor #2 Control +
96	Vac motor #2 Control -
97	Vac Motor Cut Vac Switch Input
98	Vac Motor Cut Vac Switch Output
99	High Vac horn +
100	High Vac horn -
101	Vac Motor Relay (ONLY 390, 420, 430)
102	Vac Motor Relay (all except 390, 420, 430)
103	High recovery light +
104	High recovery light -
105	C2 / 10 Squeegee actuator +
106	C2 / 3 Squeegee actuator -
107	Vacuum "on" signal to relay (For Non Solid State controlled machines)
108	Vacuum power to circuit breaker
109	Vac Switch Input (Air Logic)
110	Vac Switch Output

USED ON ONLY 390, 420 and 430

120-139		Brush Drive / Main Broom System
125		Brush drive motor +
126		Brush Motor to meter
127		Brush motor meter to circuit breaker
128		Brush motor solenoid to circuit breaker
129		Brush drive motor -
130	C2 / 11	Deck Actuator +
131	C2 / 4	Deck Actuator -
132		Deck actuator (+) power to the circuit breaker
133		Worn Motor Brush Indicator +
134		Worn Motor Brush Indicator -

140-159		Side Broom System
145		Side Broom Motor (Right) +
146		Side Broom Motor (Right) -
147		Side Broom Motor (Left) +
148		Side Broom Motor (Left) -
149		Side broom Switch
150		Side broom Diode
151		Side broom switch input
152		Side broom switch output
153		Side broom diode input
154		side broom diode output

160-199	AUX / options	
170		Back up alarm B+ Power
171	C3 / 17	Back up alarm
172		Strobe +
173		Strobe -
174		Horn -
175		Horn Switch B+
176		Horn Switch output
177	+ Buss	Headlight +
178	- Buss	Headlight -
179		Filter Shaker Switch Input B+
180		Filter Shaker Switch Output
181		Filter shaker motor -
182		Spray Jet Switch B+
183		Spray Jet Switch Output
184		Spray Jet -
185		B+ to recycling switch
186		Recycling Switch output
187		Recycling B-
188		B+ to side broom water switch
189		Output from side broom water switch
190		Side broom water B-

200 - 299	Central Command System	
201	C3 / 8	Battery Power from the Penny & Giles to the main/key switch
202	C3 / 18	Power from the main or key switch back to the P&G controller
210	5V Ref	One Touch switch power in
211		One Touch switch output
220	5V Ref	Vac/Squeegee Switch Ref
221	C3 / 11	Vac/Squeegee Switch Output
222	C2 / 5	Vac Wand Switch Ref
223	C3 / 11	Vac Wand Switch Output
230		Handle bar buttons in (From center tap of speed pot)
231		Handle bar buttons out
232	5V Ref	Speed Pot High
233		Speed Pot Center
234	0V Ref	Speed Pot Low
240		Solution Switch
241	5V Ref	Solution Pot High
242	C2 / 7	Solution Pot Center
243	0V Ref	Solution Pot Low
250	5V Ref	Brush Switch input
251		Brush Switch Output
253	5V Ref	Momentary Brush Pressure switch Terminal 1
254	C3 / 2	Momentary Brush Pressure switch Terminal 2
255	0V Ref	Momentary Brush Pressure switch Terminal 3
260	0V Ref	Reverse switch input
261	C3 / 13	Reverse switch output
270	C3 / 14	Inhibit Switch Input
271	5V Ref	Inhibit Switch output
280	C1 / 1	LCD Wire # 1
281	C1 / 2	LCD Wire # 2
282	C1 / 3	LCD Wire # 3
283	C1 / 4	LCD Wire # 4
284	C1 / 5	LCD Wire # 5
285	C1 / 6	LCD Wire # 6
290		E Stop Input
291		E Stop Output
292		Traction Mode Switch (1 pole of the brush switch) Input
293		Traction Mode Switch (1 pole of the brush switch) Output
294	5V Ref	LCD Mode Input (page switch)
295		LCD Mode Output (page switch)
296	0V Ref	Vac Switch (Air Logic)
297		Vac Switch Return

COMPUTER CONTROL SYSTEM

The Magnum series of machines is equipped with the Central Command II control system. Central Command II is designed around a very powerful controller that has an industrial computer integrated into it. The controller is linked to a Liquid Crystal Display (LCD) to relay information to the operator or the service technician. The same controller is used in the majority of our equipment, both 24 and 36 volt, but runs a different “program” for each machine. The controller utilizes unitized construction eliminating many excess components from the control panel. The switches on the dash board send input signals to the controller. The controller then interprets the inputs via the program and operates the machine accordingly. The controller has internal protection for both current overload as well as thermal protection. A large circuit breaker is used on the power feed to the controller for extra safety against overload. In the event of a malfunction the Central Command II will display a diagnostic trouble code to aid in the repairing the machine.

CONTROLLER OVERVIEW

INPUTS

The controller's input section uses a technology called tri-state logic to interpret the input from the switches. The tri-state logic is comprised of low, medium and high voltages. The inputs have the mid voltage present at them until they are either drawn low or high by a switch.

OUTPUTS

The controller has a number of outputs and each one of them is electronically protected from overload. In the event of an overload the machine is shut down by the controller and a diagnostic trouble code is displayed on the LCD screen. On some of the outputs the current limit can be adjusted via software to control the amount of current available to the circuit.

PULSE WIDTH MODULATION

The controller uses a technology called pulse width modulation to control some of the output circuits. Motors and accessories can be run using this technology in more than one way. We can change the speed of a motor as well as control the amount of time a valve is open over one second, such as in our solution system. Pulse width modulation works by sending pulses of full battery voltage to the device 14,000 times a second. The length of the pulses determines the speed of the motor. This is a much more efficient way of running an electrical device at less than 100% operation.

CONTINUITY TESTING

Four of the outputs; traction drive, parking brake, brush & vacuum have a continuity checking feature that monitors the device and the wiring to it from the controller for an open circuit. This monitoring can be turned on and off for each circuit independently through the programming of the controller.

SOFT START

Three of the outputs; traction, brush & vacuum, have a soft start function on them. This function provides the ability to start and stop a motor gradually over a measured period of time, 0-10 seconds. This aids in the longevity of the motors and anything driven by them as it greatly decreases the shock load on them. The soft start settings are changed through the controller programming.

CONNECTIONS

There are 3 different types of connections that are used on the controller.

MOLEX MINI FIT JR.

The Molex Mini Fit Jr. connectors are used for all of the inputs and the low amperage outputs. They require special tools to service and replace them. See the “Electrical System” Section 12 for serving information.

AMP TERMINALS

The AMP terminals are specially designed terminals capable of handling high amperage connections. These are used on the high amp outputs on the V.3 controls. See the “Electrical System” Section 12 for serving information.

BINDING POST TERMINALS

Binding post terminals offer the best connection available and are used for the main battery terminals on both the V.3 & V.4 controllers. On the V.4 controllers the high output connections have been changed to the binding post type.

TIMED CIRCUITS

The controller has the capability to control a circuit with a certain amount of logic. We can customize the operation of a component beyond the simple on off operation. Timers are used for our vacuum motors and our squeegee actuators to make the machine operation more user friendly. The timer settings are changed through the controller programming.

BATTERY METER

The battery meter is integrated into the controller and the status of the battery is displayed on the LCD screen. The battery condition is monitored very differently from a traditional battery meter. The battery condition is calculated by measuring the internal resistance of the battery pack. The battery meter is designed to read properly when the battery is under load. It is not uncommon for the battery gauge to climb when the machine is under load.

DOWN PRESSURE CONTROL

The down pressure of the scrub deck is monitored and maintained by the controller. It is adjusted many times a second to deliver consistent brush pressure with changing floor conditions. The controller monitors the amp draw of the scrub motors which increases and decreases with brush deck pressure and floor surface change. The amp draw has a target value and the controller works to keep the motors at the selected amp draw by increasing or decreasing brush pressure. The target pressure is represented on the LCD display and changed using the brush pressure switch on the control panel.

LCD DISPLAY

The LCD display is a multi-function display that conveys machine information to the operator about the operation state of the machine and diagnostic information in the event of a malfunction. The LCD display communicates to the controller on a serial data connection that is made via the 6 wire connector running from the display to the controller. The LCD display has 4 different screens with different information presented on each.

There are four versions of the LCD display. The first version of the LCD display has 3 screens that you can page through with the page button plus a diagnostic code screen. The second, third & fourth versions of the LCD display have two screen you can page through and a diagnostic code screen.

VERSION 1

SCREEN 1

Screen 1 is the default screen that appears after the machine has powered up.

1: BATTERY METER - This meter shows the charge level of the batteries in the machine. This gauge is designed to read properly while the machine is in use and therefore will vary up and down during usage of the machine.

2: BRUSHES RUNNING - This icon shows when the controller receives an input to run the scrub brushes.

3: SOLUTION DISPENSING - This icon indicates that the controller is receiving an input to dispense water. The icon flashes in relationship to the amount of time the valve is on for. This is controlled by the solution potentiometer on the control panel.

4: BRUSH PRESSURE GAUGE - This icon is a bar graph representation of the desired brush pressure. It is divided into 5 segments and each segment indicates more pad pressure.

5: VACUUM MOTOR - This icon indicates the controller is receiving an input to run the vacuum motor.

6: HIGH THROTTLE - This icon indicates one or more throttle inputs, such as the green handle bar buttons or the reverse switch, were activated when the machine was powered on. To clear this icon make sure no buttons or switches are depressed and cycle the power to the machine.

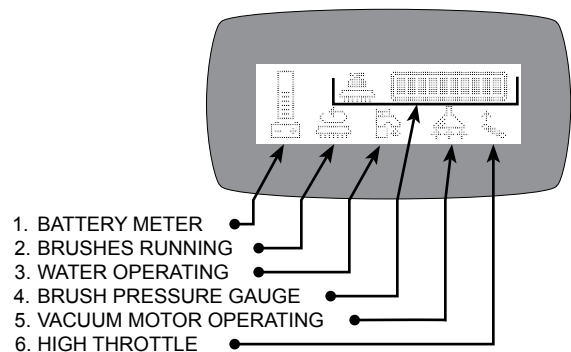

SCREEN 2

To access screen 2, push the green page button on the control panel once.

7: KEY SWITCH HOUR METER

This hour meter represents the total number of hours the machine has been powered on. This does not mean, however, that the machine has been used this long, just that it has had the power on for the time indicated.

8: BATTERY METER

This meter shows the charge level of the batteries in the machine. This gauge is designed to read properly while the machine is in use, and therefore will vary both up and down during usage of the machine.

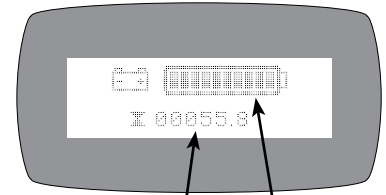

7. KEY SWITCH HOUR METER
8. BATTERY METER

SCREEN 3

To access this from screen 1 press the green page button twice.

9: BATTERY METER - This meter shows the charge level of the batteries in the machine. This gauge is designed to read properly while the machine is in use and therefore will vary both up and down during usage of the machine.

10: SCRUB HOURS - The hour total listed here indicates the total number of hours the brush deck has been operated on the machine.

11: TRACTION HOURS - The hour total listed here indicates the total number of hours the traction drive has been operated on the machine.

12: KEY SWITCH HOUR METER - This hour meter represents the total number of hours the machine has been powered on. This does not mean however that the machine has been used this long, just that it has had the power on for the time indicated.

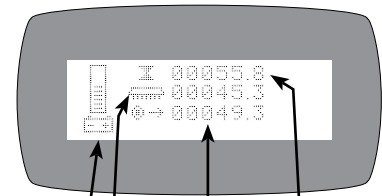

9. BATTERY GAUGE
10. SCRUB HOURS
11. TRACTION HOURS
12. KEY SWITCH HOURS

SCREEN 4

This screen will appear automatically in the event of a fault being present in the machine. Machine operation will be suspended in most cases until the cause of the code is remedied.

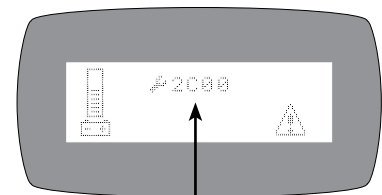

13. DIAGNOSTIC CODE

VERSION 2

SCREEN 1

Screen 1 is the default screen that appears after the machine has powered up.

1: BATTERY METER - This meter shows the charge level of the batteries in the machine. This gauge is designed to read properly while the machine is in use and therefore will vary both up and down during usage of the machine.

2: WATER VOLUME - This icon shows when the output volume that the controller has set.

3: BRUSH PRESSURE GAUGE - This icon is a bar graph representation of the desired brush pressure. It is divided into 5 segments and each segment indicates more pad pressure.

4: BRUSHES OPERATING - This icon shows when the controller receives an input to run the scrub brushes

5: WATER VALVE OPERATING - This icon indicates that the controller is receiving an input to dispense water. The icon flashes in relationship to the amount of time the valve is on for. This is controlled by the solution potentiometer or solution toggle switch on the control panel.

6: KEY SWITCH HOUR METER - This hour meter represents the total number of hours the machine has been powered on. This does not mean, however, that the machine has been used this long just that it has had the power on for the time indicated.

7: VACUUM MOTOR - This icon indicates the controller is receiving an input to run the vacuum motor.

8: HIGH THROTTLE DISABLE - This icon indicates one or more throttle inputs, such as the green handle bar buttons or the reverse switch, were activated when the machine was powered on. Make sure no buttons or switches are depressed and cycle the power to the machine.

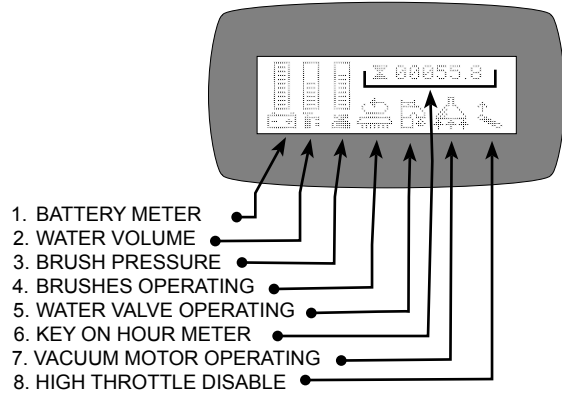

SCREEN 2

To access screen 2, push the green page button on the control panel once.

7: KEY SWITCH HOUR METER

This hour meter represents the total number of hours the machine has been powered on. This does not mean, however, that the machine has been used this long, just that it has had the power on for the time indicated.

8: BATTERY METER

This meter shows the charge level of the batteries in the machine. This gauge is designed to read properly while the machine is in use, and therefore will vary both up and down during usage of the machine.

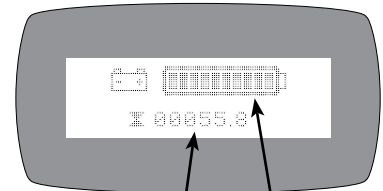

7. KEY SWITCH HOUR METER
8. BATTERY METER

SCREEN 3

To access this from screen 1, press the green page button twice.

9: BATTERY METER - This meter shows the charge level of the batteries in the machine. This gauge is designed to read properly while the machine is in use and therefore will vary during usage of the machine.

10: SCRUB HOURS - The hour total listed here indicates the total number of hours the brush deck has been operated on the machine.

11: TRACTION HOURS - The hour total listed here indicates the total number of hours the traction drive has been operated on the machine.

12: KEY SWITCH HOUR METER - This hour meter represents the total number of hours the machine has been powered on. This does not mean however that the machine has been used this long just that it has had the power on for the time indicated.

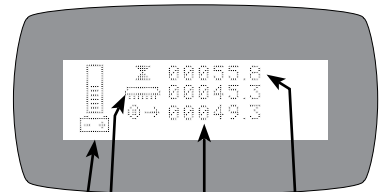

9. BATTERY GAUGE
10. SCRUB HOURS
11. TRACTION HOURS
12. KEY SWITCH HOURS

SCREEN 4

This screen will appear automatically in the event of a fault being present in the machine. Machine operation will be suspended until the cause of the code is remedied.

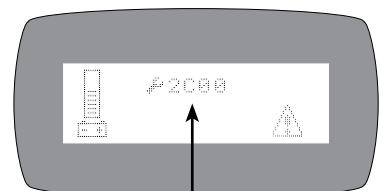

FAULT CODE

VERSION 3**SCREEN 1**

Screen 1 is the default screen that appears after the machine has powered up.

1: BATTERY METER - This meter shows the charge level of the batteries in the machine. This gauge is designed to read properly while the machine is in use and therefore will vary both up and down during usage of the machine.

2: WATER VOLUME - This icon shows when the output volume that the controller has set.

3: BRUSH PRESSURE GAUGE - This icon is a bar graph representation of the desired brush pressure. It is divided into 5 segments and each segment indicates more pad pressure.

4: BRUSHES OPERATING - This icon shows when the controller receives an input to run the scrub brushes

5: WATER VALVE OPERATING - This icon indicates that the controller is receiving an input to dispense water. The icon flashes in relationship to the amount of time the valve is on for. This is controlled by the solution potentiometer or solution toggle switch on the control panel.

6: KEY SWITCH HOUR METER - This hour meter represents the total number of hours the machine has been powered on. This does not mean, however, that the machine has been used this long just that it has had the power on for the time indicated.

7: VACUUM MOTOR - This icon indicates the controller is receiving an input to run the vacuum motor.

8: HIGH THROTTLE DISABLE - This icon indicates one or more throttle inputs, such as the green handle bar buttons or the reverse switch, were activated when the machine was powered on. Make sure no buttons or switches are depressed and cycle the power to the machine.

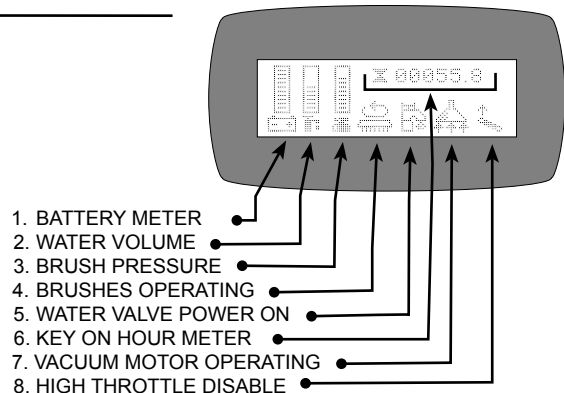

SCREEN 2

To access this from screen 1, press the green page button twice.

9: BATTERY METER - This meter shows the charge level of the batteries in the machine. This gauge is designed to read properly while the machine is in use and therefore will vary during usage of the machine.

10: SCRUB HOURS - The hour total listed here indicates the total number of hours the brush deck has been operated on the machine.

11: TRACTION HOURS - The hour total listed here indicates the total number of hours the traction drive has been operated on the machine.

12: KEY SWITCH HOUR METER - This hour meter represents the total number of hours the machine has been powered on. This does not mean however that the machine has been used this long just that it has had the power on for the time indicated.

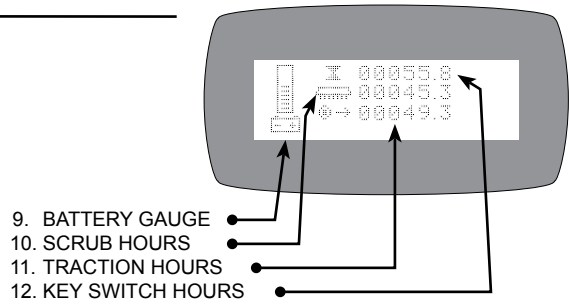

VERSION 4**SCREEN 1**

Screen 1 is the default screen that appears after the machine has powered up.

1: BATTERY METER - This meter shows the charge level of the batteries in the machine. This gauge is designed to read properly while the machine is in use and therefore will vary both up and down during usage of the machine.

2: WATER VOLUME - This icon shows when the output volume that the controller has set.

3: BRUSH PRESSURE GAUGE - This icon is a bar graph representation of the desired brush pressure. It is divided into 5 segments and each segment indicates more pad pressure.

4: BRUSHES OPERATING - This icon shows when the controller receives an input to run the scrub brushes

5: WATER VALVE OPERATING - This icon indicates that the controller is receiving an input to dispense water. The icon flashes in relationship to the amount of time the valve is on for. This is controlled by the solution potentiometer or solution toggle switch on the control panel.

6: SUDS SYSTEM ICON - This icon indicates that the SUDS system is turned on. When the SUDS system is on setting 1 there are 2 sets of bubbles that show and when the SUDS system is on setting 2 (HI) there are 4 sets of bubbles that show..

7: VACUUM MOTOR - This icon indicates the controller is receiving an input to run the vacuum motor.

8: HIGH THROTTLE DISABLE - This icon indicates one or more throttle inputs, such as the green handle bar buttons or the reverse switch, were activated when the machine was powered on. Make sure no buttons or switches are depressed and cycle the power to the machine.

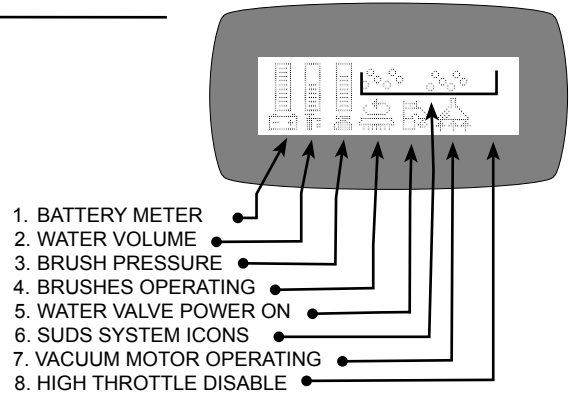

SCREEN 2

To access this from screen 1, press the green page button twice.

9: BATTERY METER - This meter shows the charge level of the batteries in the machine. This gauge is designed to read properly while the machine is in use and therefore will vary during usage of the machine.

10: SCRUB HOURS - The hour total listed here indicates the total number of hours the brush deck has been operated on the machine.

11: TRACTION HOURS - The hour total listed here indicates the total number of hours the traction drive has been operated on the machine.

12: KEY SWITCH HOUR METER - This hour meter represents the total number of hours the machine has been powered on. This does not mean however that the machine has been used this long just that it has had the power on for the time indicated.

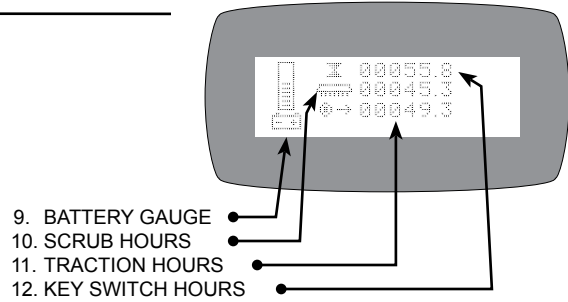

ON BOARD DIAGNOSTICS

The Central Command II control system utilizes a Diagnostic Code system that displays diagnostic codes on the LCD display should a malfunction of the machine occur. The diagnostic code can be looked up in the diagnostic code chart and it will assist you in determining the cause of malfunction.

DIAGNOSING THE CONTROL SYSTEM

The Central Command II system with all its robust capabilities is also very easy to diagnose and repair. To diagnose the system a clamp type DC amp meter and high impedance DC Volt meter are required. The machine's LCD display will also be utilized. It is important never to use jumper wires connected to battery power or ground for testing as this can instantly destroy the controller.

The controller is not field serviceable in any way and needs to be replaced in the event of failure.

METERS

It is important to use a high quality meter when diagnosing the control systems on our equipment as a low quality meter can ruin a controller just by taking a measurement. A good rule of thumb is if you didn't pay at least \$50 for your meter don't use it on our equipment. NEVER use analog meters for diagnosing the controller systems on our machines as they WILL damage the machine. A DC amp clamp is imperative for diagnosis of the control systems, most DC amp clamps have a built in DC volt meter too. In addition to your meter(s) you should have a quality set of test leads that have alligator clamps on the ends.

MEASUREMENTS

When measuring for voltage in the control system unless otherwise specified you will always set your meter to the DC volts scale and connect your negative (-) test lead to the negative (-) battery cable or buss bar. When measuring for amp draw you will always measure around ONLY 1 wire (+) OR (-) going to the device in question. Place the meter clamp on the wire with power off to the device. Zero out the meter and then power up the device and take your readings.

LCD DISPLAY

The LCD is a critical component and can cause the machine to operate improperly or not operate at all, There is a computer data link that is established between the LCD and the computer when the machine is powered on and all the computer information is routed in a loop through the LCD display. For this reason if an LCD fails it can cause a variety of results from making the machine not turn on to making it not turn off.

INPUTS

The switches in the Central Command II System receive reference voltages from the controller and then send signals, in the form of low or high voltage, to the controller. The controller interprets these signals and then the computer and it's program inside the controller decide what device there is a request for and how it should operate the device.

TRI-STATE LOGIC

The Central Command II system uses very low voltage throughout its control system. This voltage is less than battery voltage and the controller will be destroyed if battery voltage is induced into the control circuits. The tri-state logic uses 3 voltages as follows;

LOW = 0.0 - 0.3 volts

MID = 0.8 - 2.7 volts

HIGH = 4.8 - 5.2 volts

The low and high voltages are reference voltages created by the controller. These voltages are sent to the various controller inputs via the control panel switches. The controller then makes the machine operate a certain way. All inputs at the controller, with the exception of the throttle input, are at a voltage of 0.8 to 2.6 volts when they are at a "neutral" or un-switched state. When a signal is sent to an input via a switch it is either a "LOW" or "HIGH" reference signal. The computer monitors the input terminal many times a second and when the voltage of it changes the computer reacts accordingly to the program in it changing the outputs of the controller.

INPUTS- VARIABLE VOLTAGE

In addition to the standard tri-state logic inputs the controller also used varied voltage inputs. Examples of these inputs would be the throttle and the solution circuit. On these inputs the a high and low signal are fed to a 5K potentiometer on each of the outside terminals. The voltage is summed by the potentiometer and the summed voltage is sent out the center terminal of the potentiometer to the input terminal on the controller. As the potentiometer is rotated the center wiper contact inside increases or decreases its distance from the high reference signal creating a sweeping voltage from about 0.0 volts to 5.1 volts. This varied voltage is interpreted by the controller and the outputs are then controlled according to the program.

OUTPUTS

The outputs of the controller are controlled by the embedded computer and its program. It interprets the inputs and energizes the outputs accordingly. The outputs on the controller are driven by transistors and not relays so they are different to diagnose than a traditional control system. An important thing to be aware of is when an output is turned off there can be as much of 80% of the voltage present at the output when you measure it with a meter. The voltage that is present comes from the continuity test that the controller continually runs on some of the output circuits. This a very low amp signal that can register on your meter but is not enough amperage to power a motor or other accessory. To consider an output to be "on" or activated it must be 95% of battery voltage.

SOLUTION SOLENOID: AUX 3

The solution solenoid output of the controller provides a ground to the solution solenoid valve. The positive voltage feed to the solenoid valve comes from the switched B+ power from the controller on pin #8 of the 14 pin Molex connector at the controller.

PROGRAMMING

We use the same controllers on nearly all of our machines. The controller's embedded computer needs a set of instructions to operate the machine. The instructions are the program the computer runs and we can modify this program by changing its "parameters". This is what makes it possible to use the same controller in most of our machines but have each one of them react differently. By changing these parameters we can make the piece of equipment function in different ways. An example of this is by changing the parameters we can make brush deck of a machine drop to the floor when the machine starts scrubbing and then pick itself up when the machine stops. If we adjusted another parameter we could make the brushes raise up when the machine went in reverse without having the operator manipulate a switch. In order to change the parameters in a controller a T-194 programming kit is necessary. With a laptop computer and the programming kit access can be gained to the parameters of the machine and they can be modified to make the machine react differently.

The controller has 135 parameters that can be modified through programming. To program the controller a programming kit and special software are necessary. The kit for this is available from the factory. The part number for the kit is T-194 and it includes the following:

- 1 Central Command II Programmer CD
- 1 Controller computer interface cable
- 1 USB serial port adapter
- 1 Controller protected power cable
- 1 Jumper key
- 1 Latest version of the Electrical Service Guide
- 1 T-194 programming guide

This kit is required to make any changes in the program for the computer.

MODEL 250/GTX BACK-UP ALARM DIAGNOSTIC FLOW CHART 1 of 1

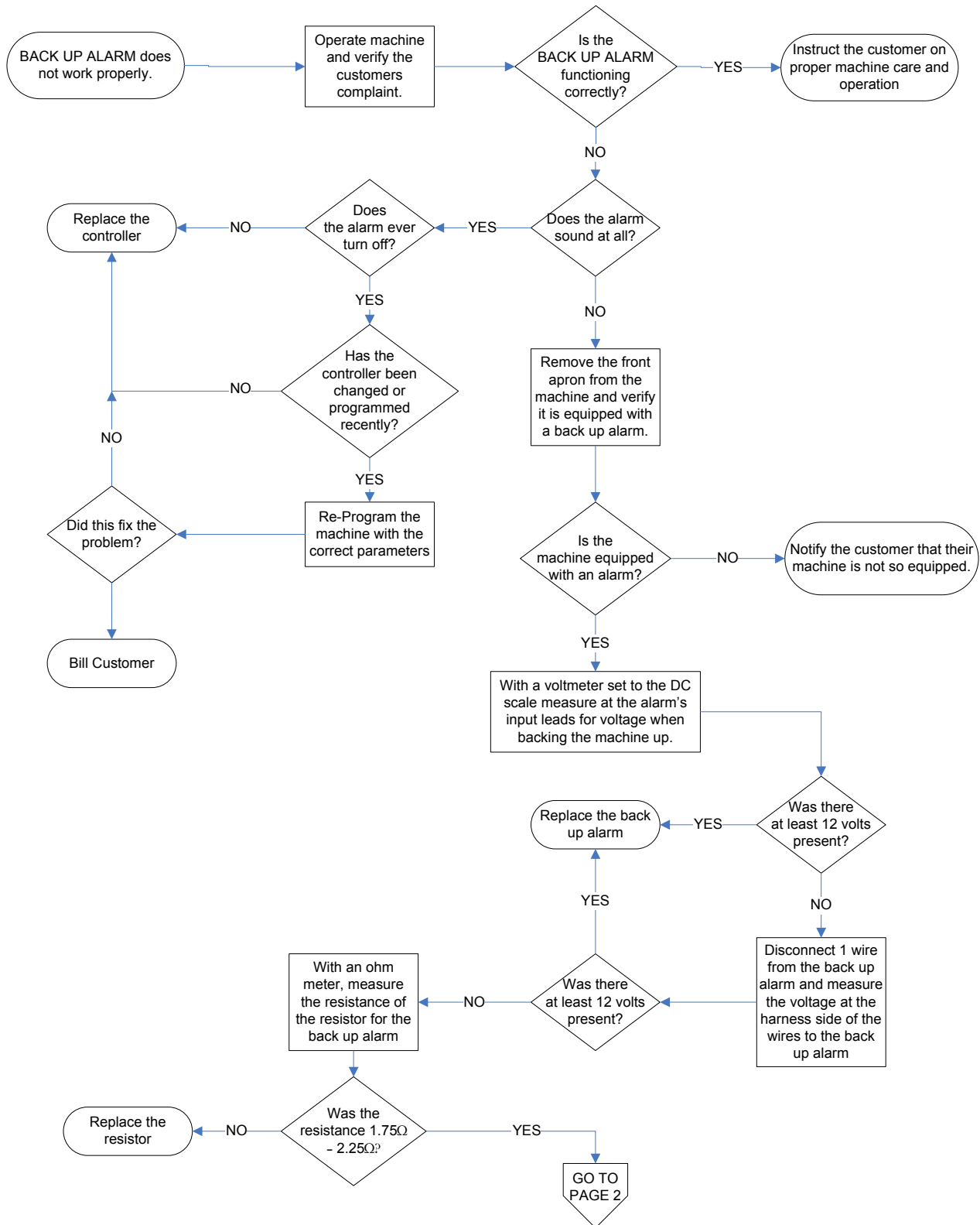

MODEL 250/GTX BATTERY DIAGNOSTIC FLOW CHART
1 of 1

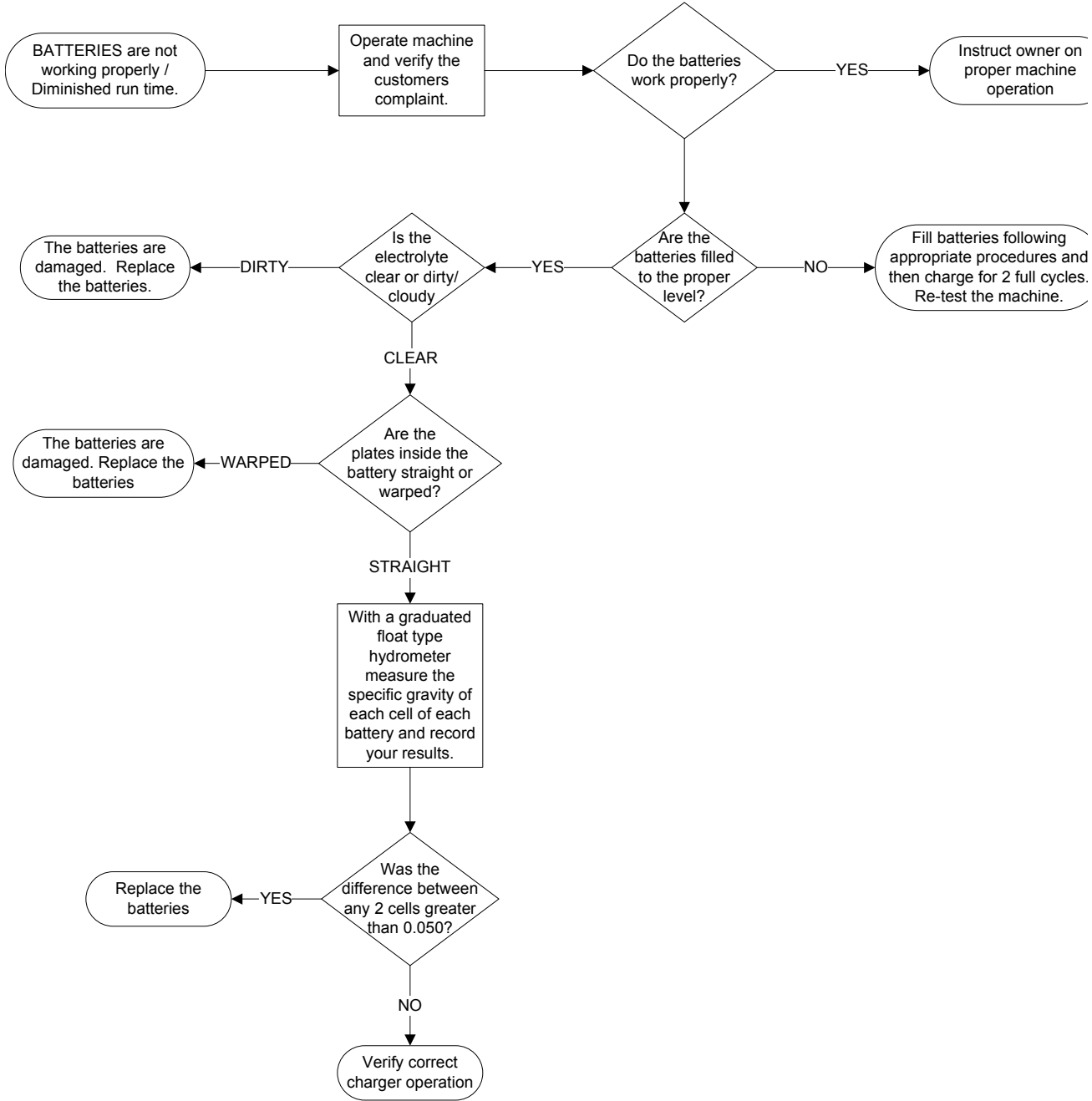

MODEL 250/GTX BRUSH DECK ACTUATOR DIAGNOSTIC FLOW CHART 1 of 1

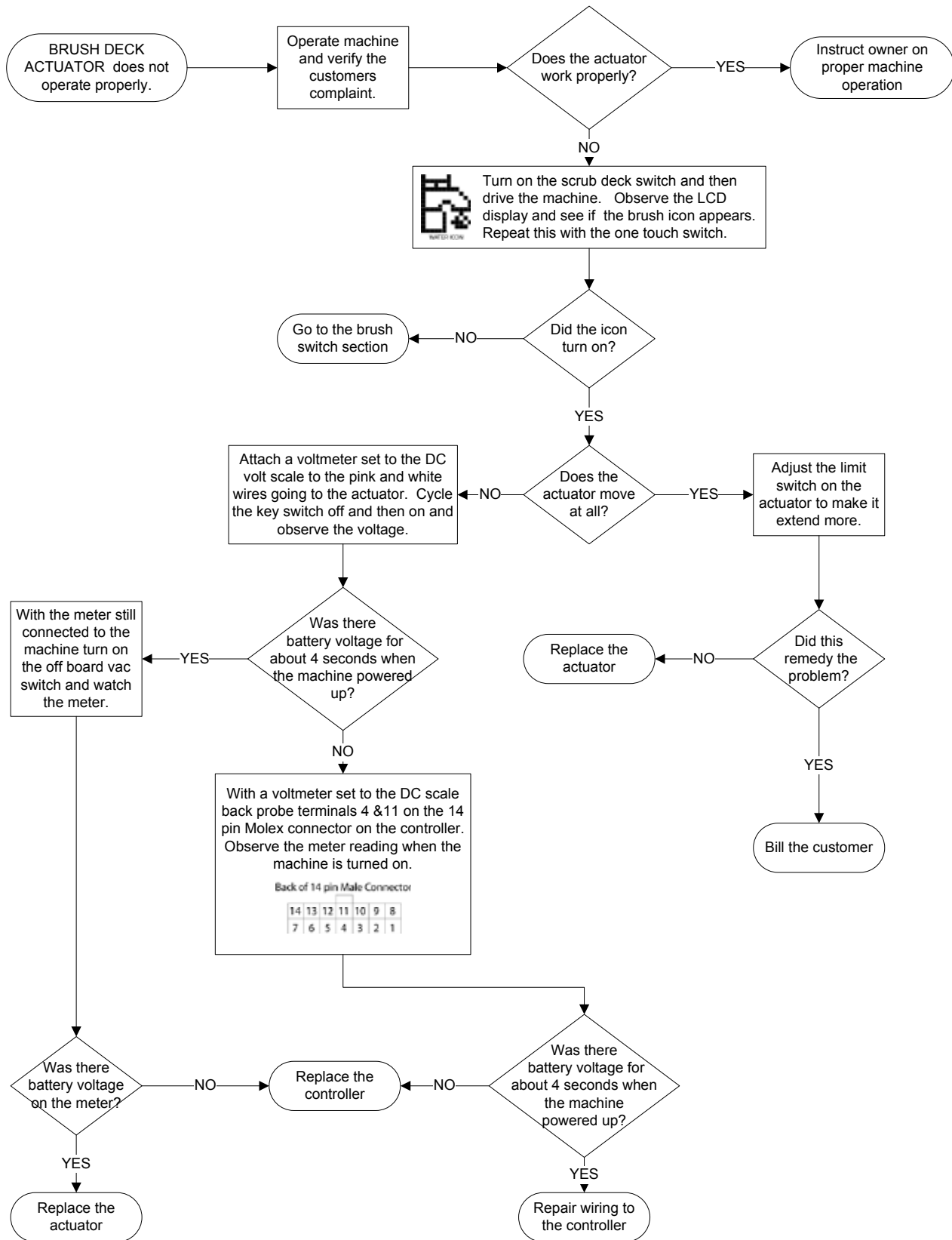

MODEL 250/GTX BRUSH PRESSURE SWITCH DIAGNOSTIC FLOW CHART
1 of 2

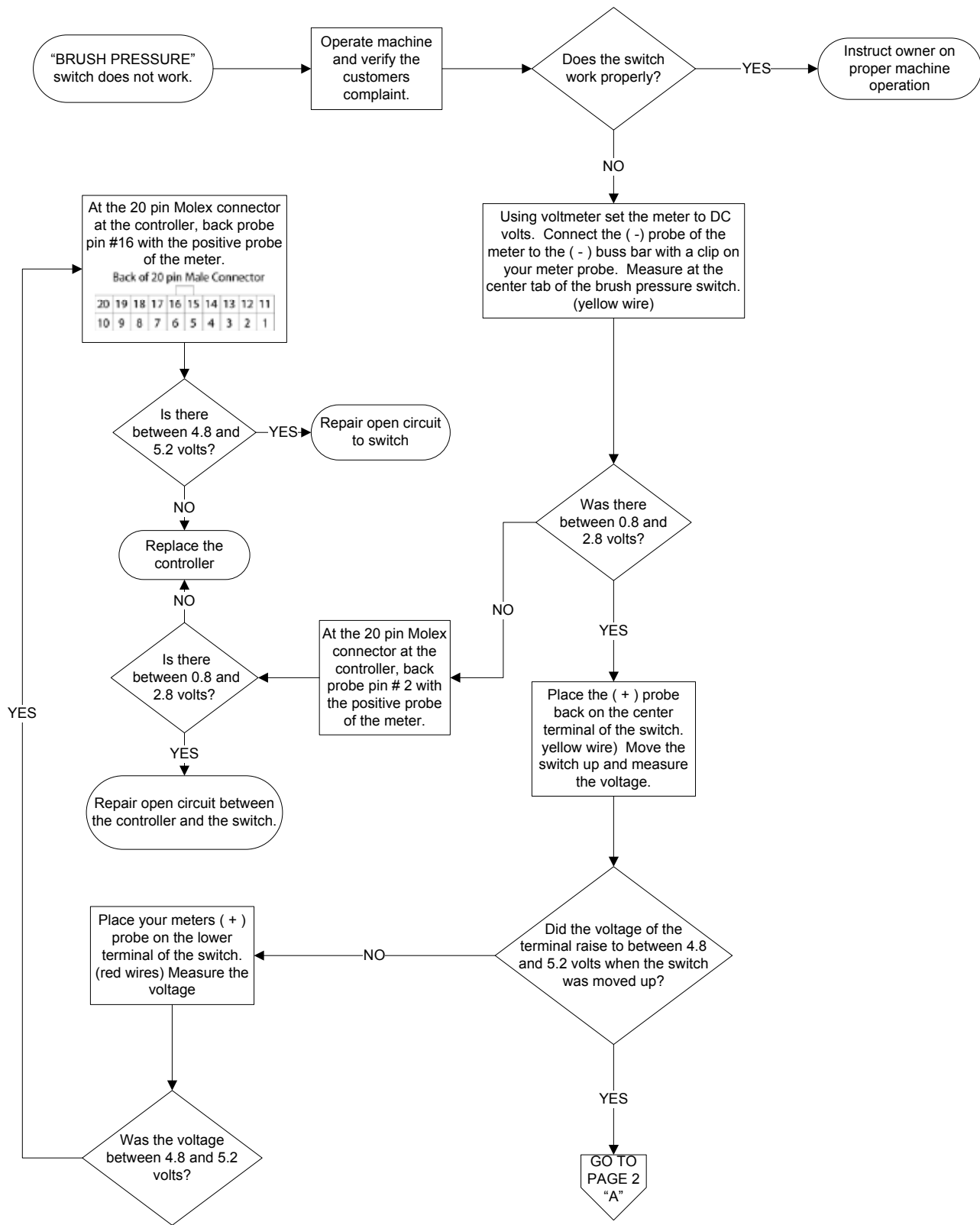

MODEL 250 BRUSH PRESSURE SWITCH DIAGNOSTIC FLOW CHART 2 of 2

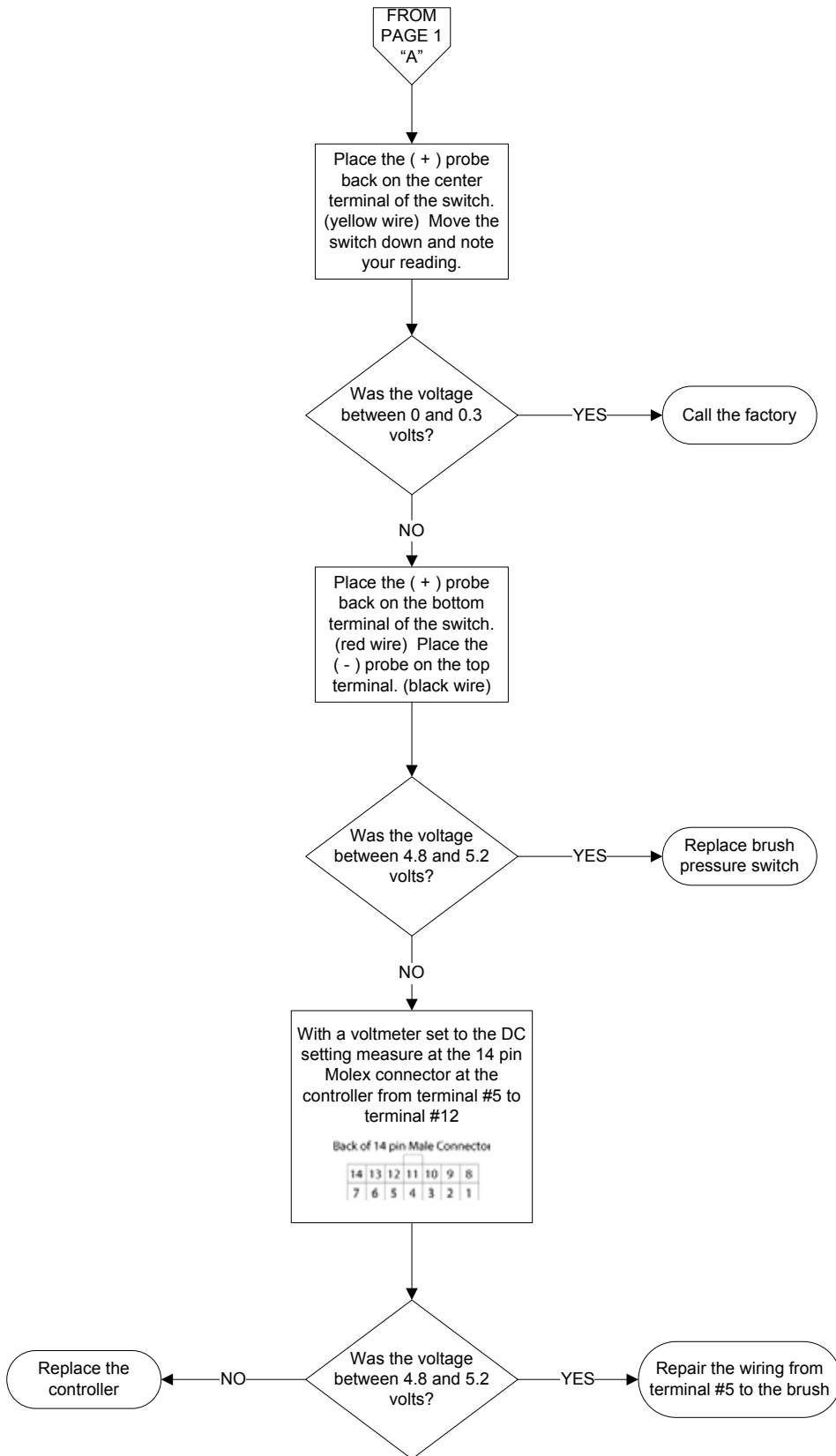

MODEL 250/GTX BRUSH SWITCH DIAGNOSTIC FLOW CHART
1 of 2

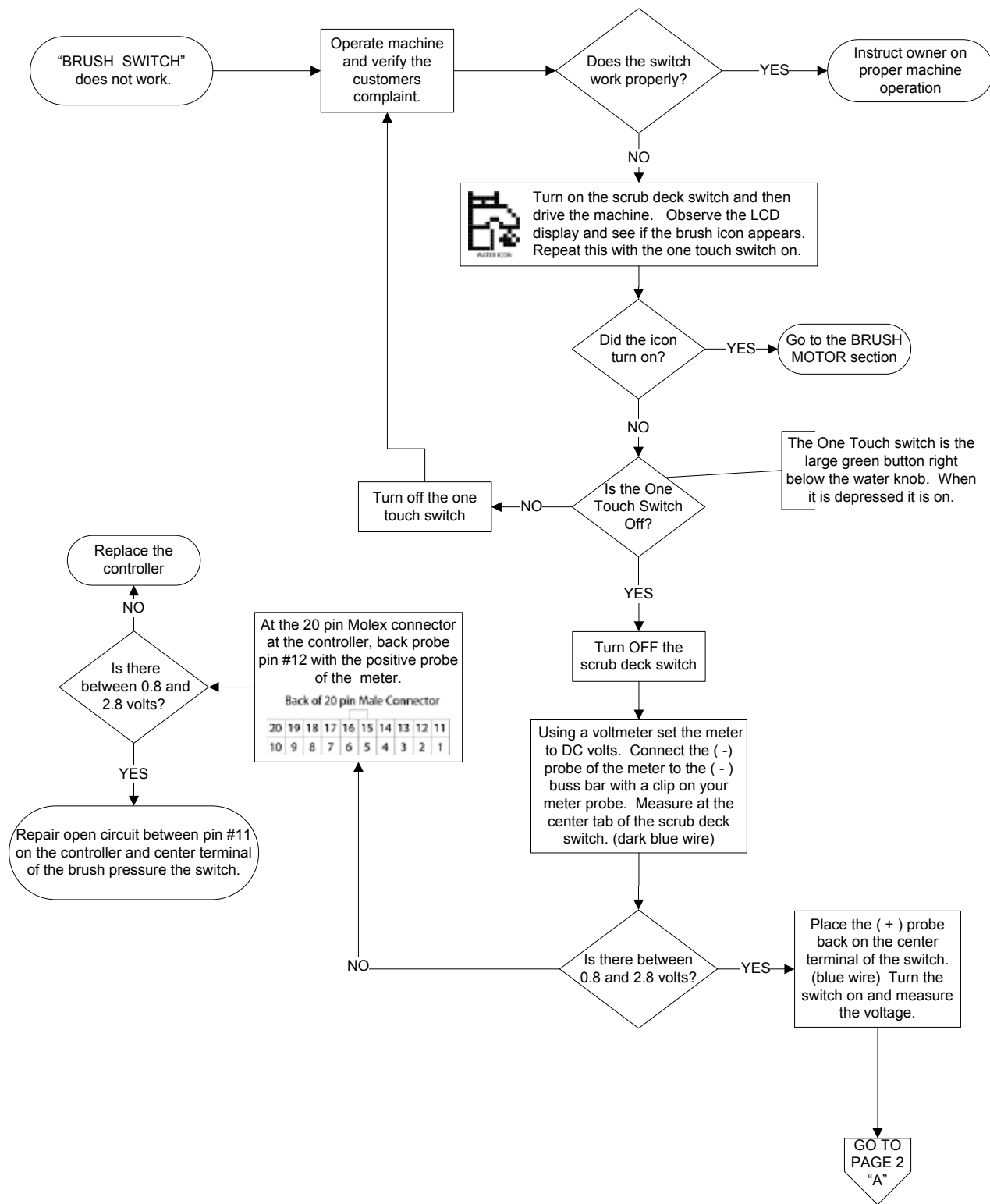

MODEL 250/GTX BRUSH SWITCH DIAGNOSTIC FLOW CHART 2 of 2

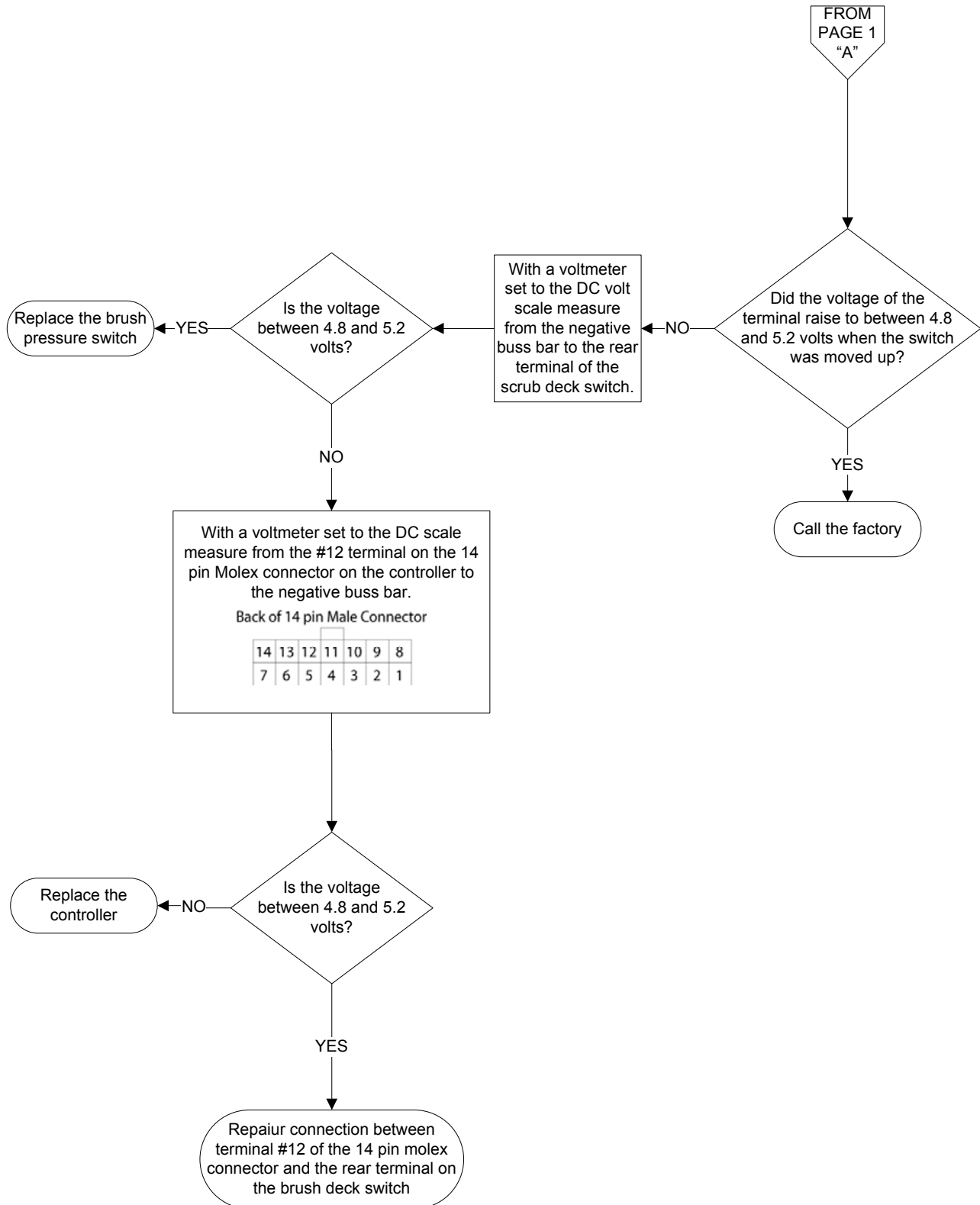

MODEL 250/GTX BUSS RELAY DIAGNOSTIC FLOW CHART
1 of 2

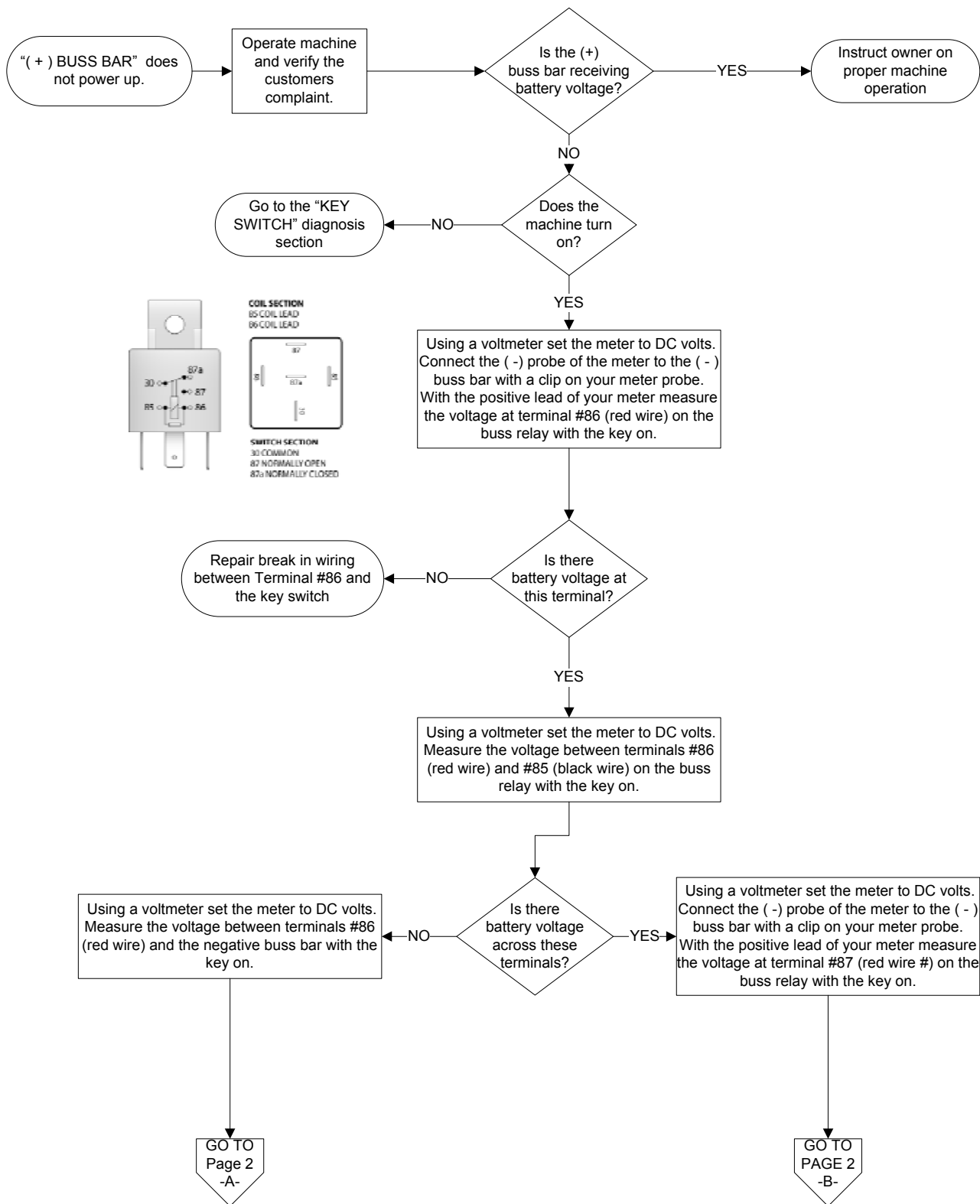

MODEL 250/GTX BUSS RELAY DIAGNOSTIC FLOW CHART

2 of 2

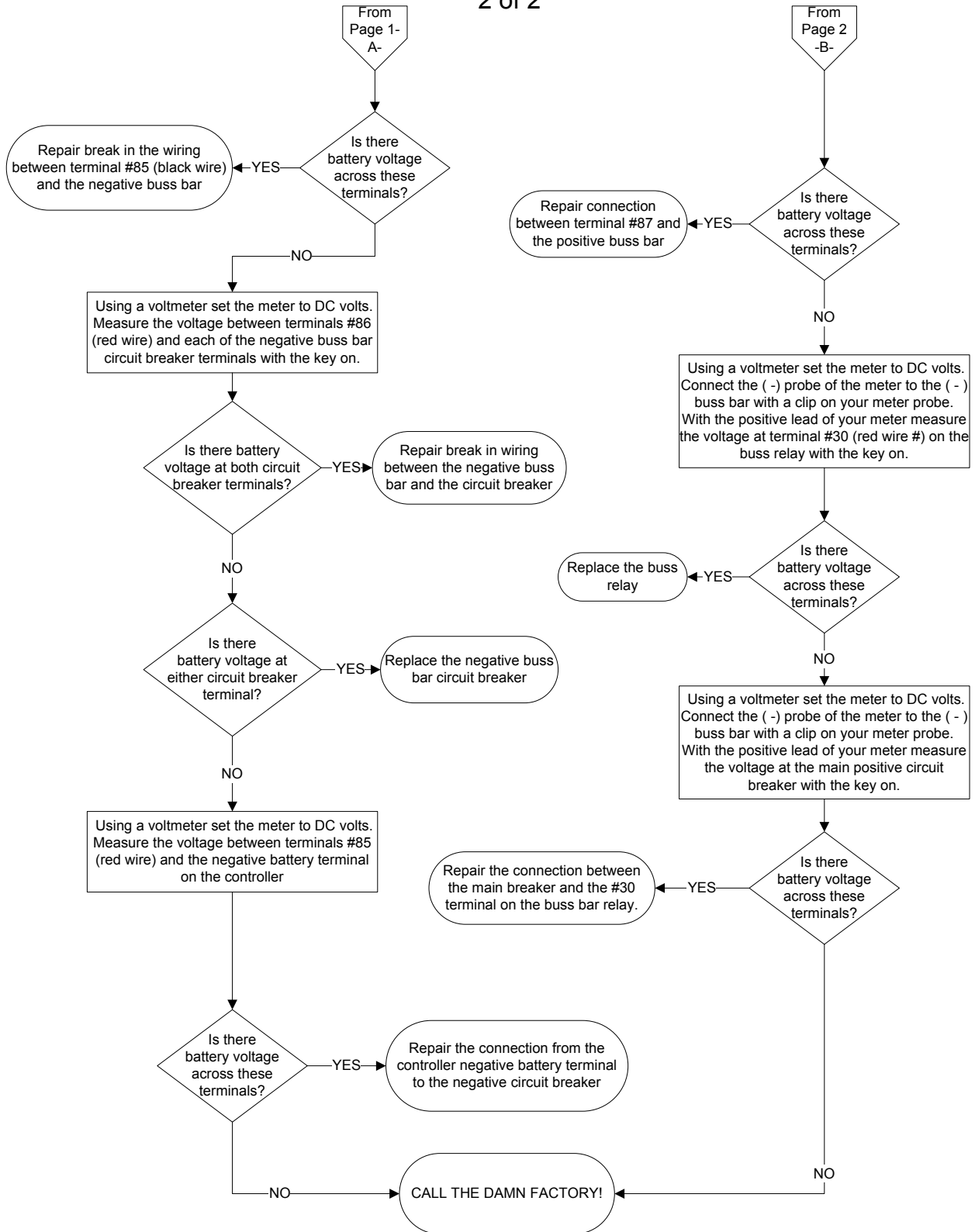

MODEL 250/GTX SOLUTION SOLENOID VALVE DIAGNOSTIC FLOW CHART

1 of 2

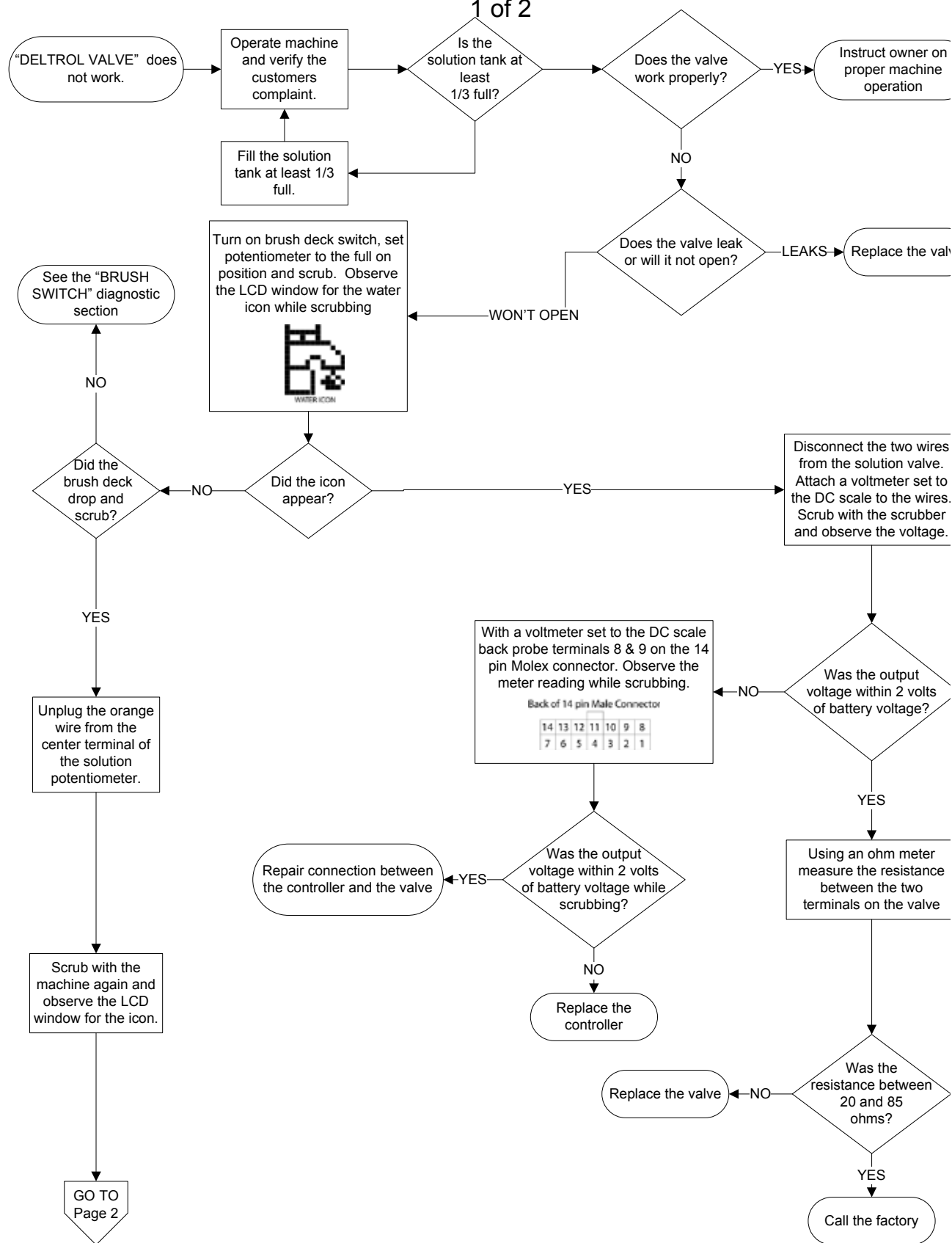

MODEL 250/GTX SOLUTION SOLENOID VALVE DIAGNOSTIC FLOW CHART

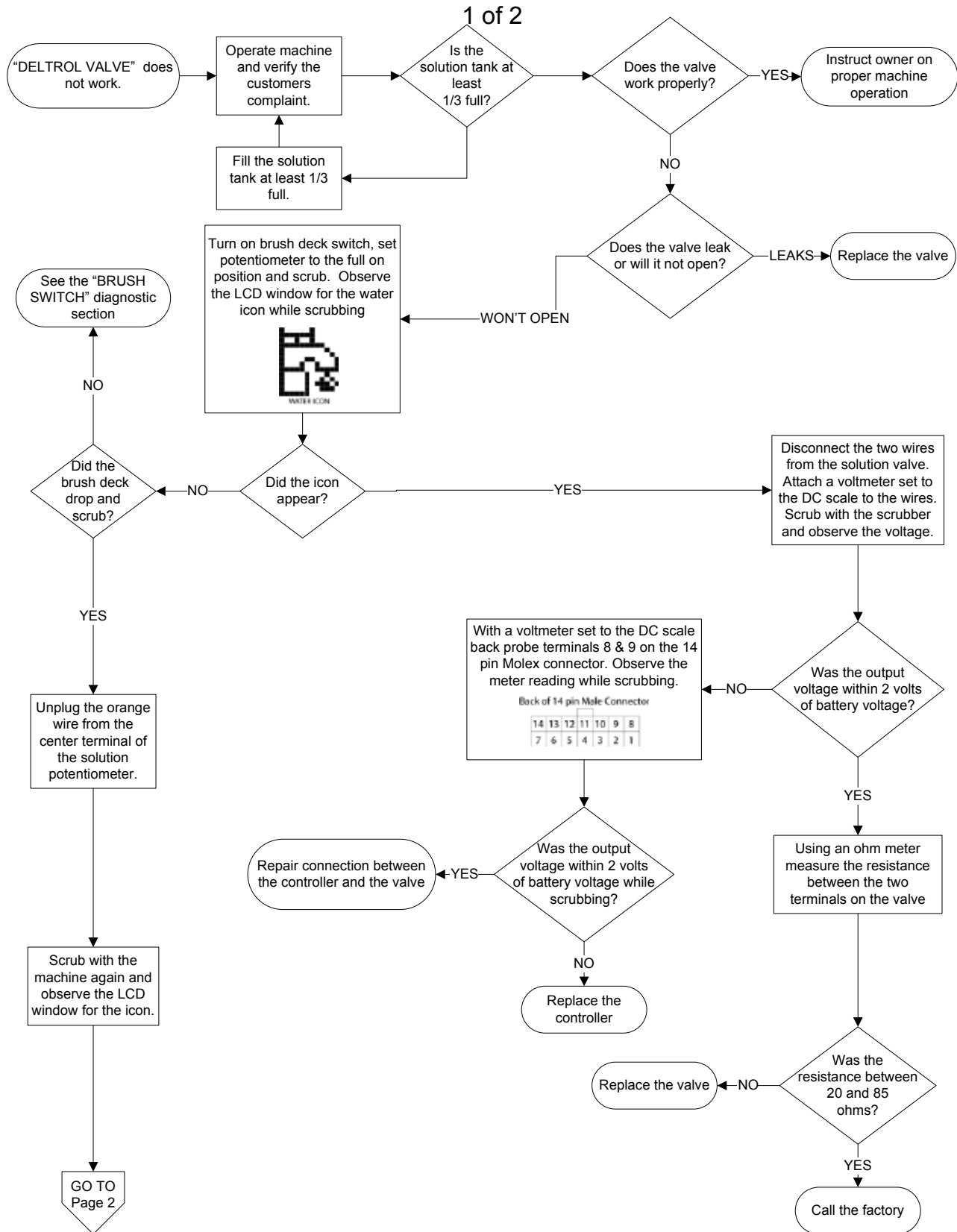

MODEL 250/GTX DRIVE MOTOR DIAGNOSTIC FLOW CHART

1 of 1

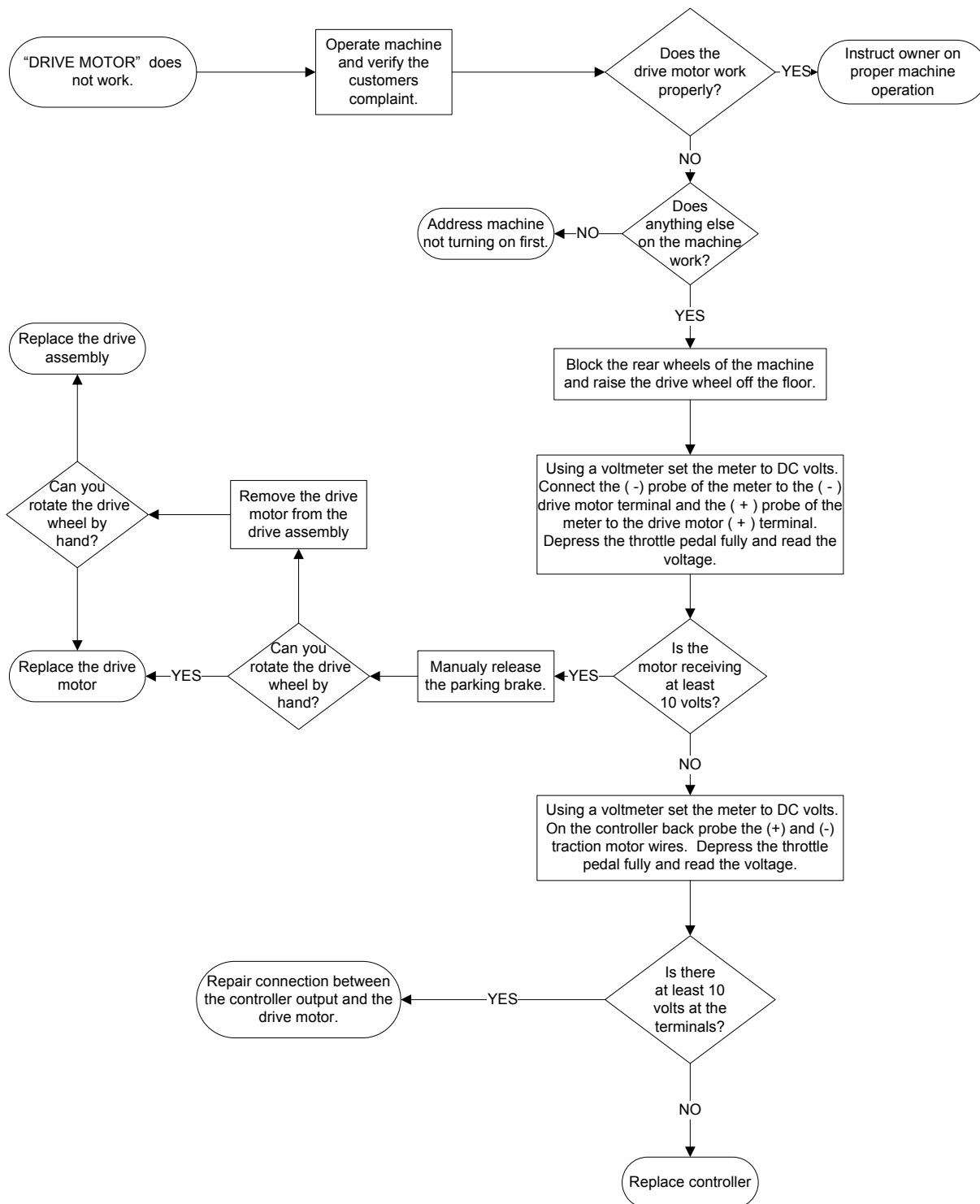

MODEL 250/GTX EMERGENCY STOP DIAGNOSTIC FLOW CHART 1 of 1

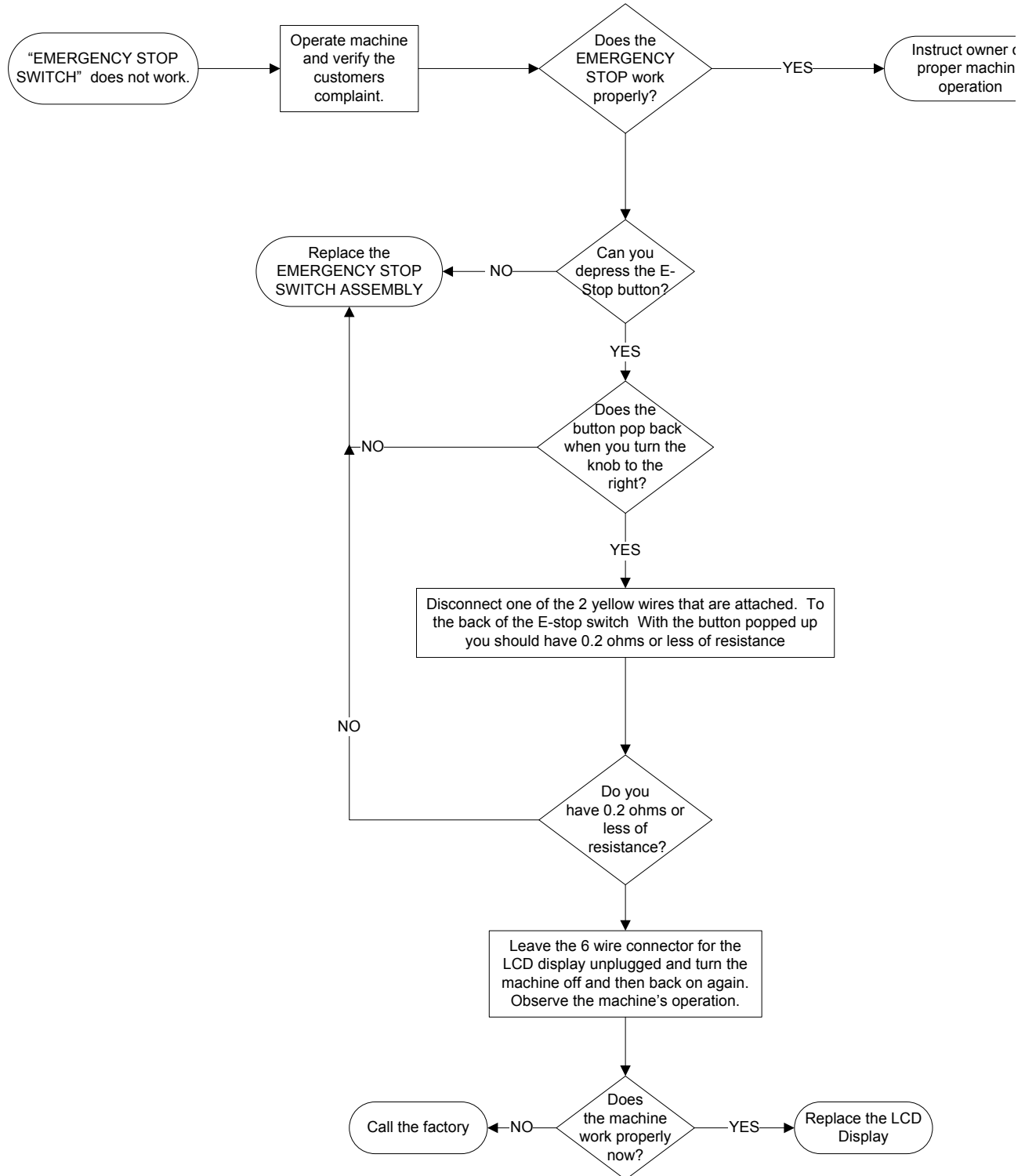

MODEL 250/GTX FOOT PEDAL DIAGNOSTIC FLOW CHART

1 of 1

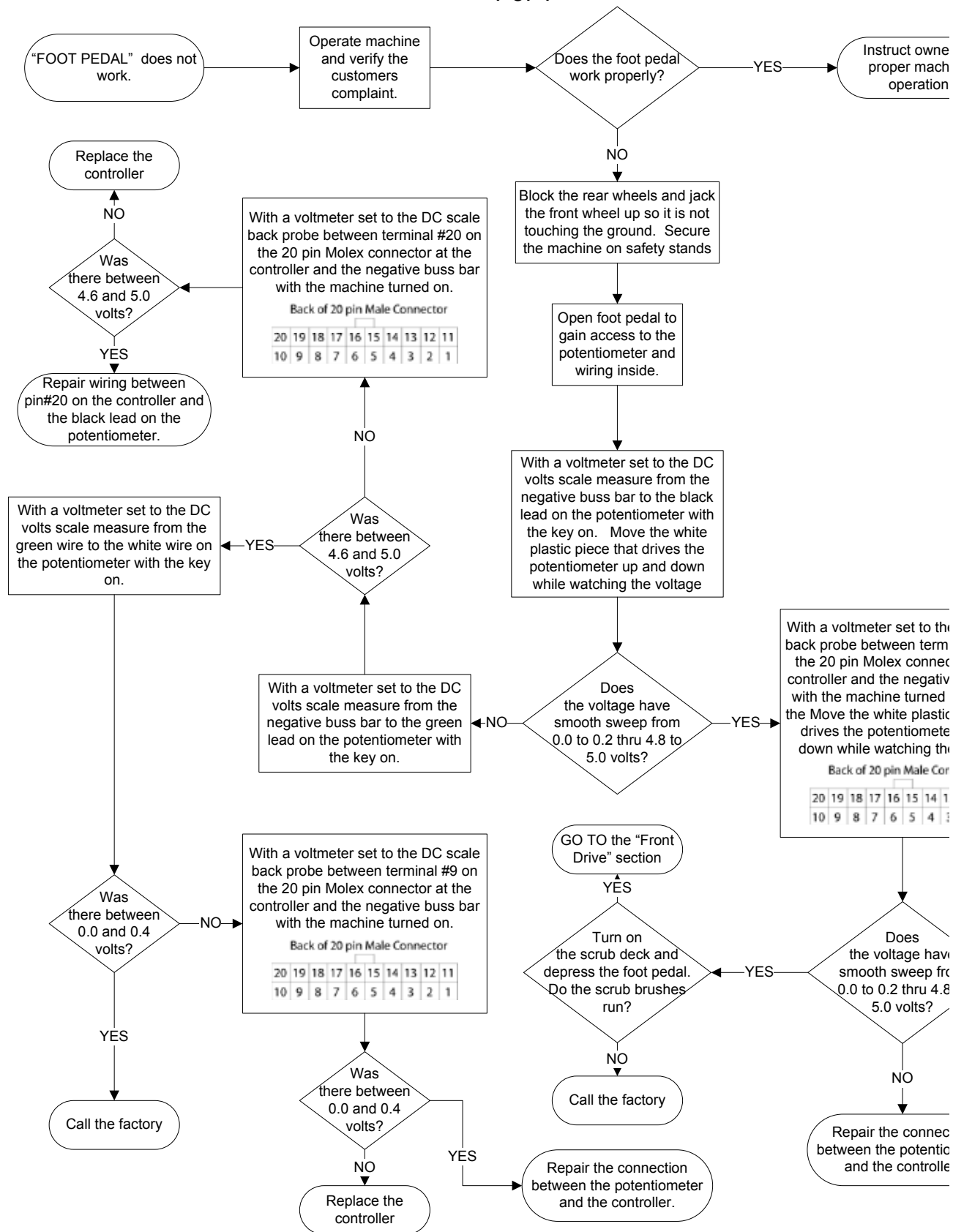

390/420 EMERGENCY STOP DIAGNOSTIC FLOW CHART 1 of 1

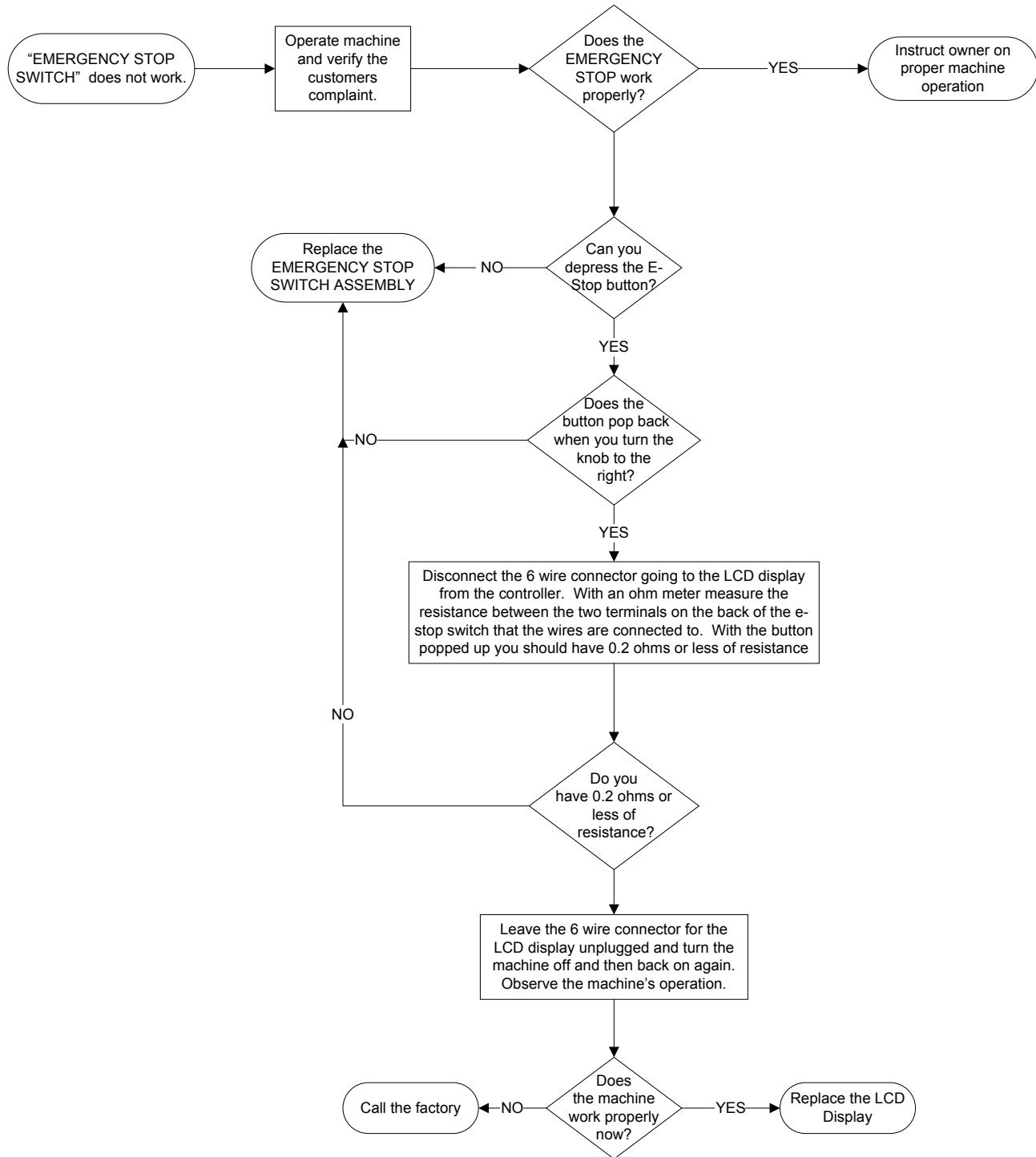

MODEL 250/GTX FOOT PEDAL DIAGNOSTIC FLOW CHART

1 of 1

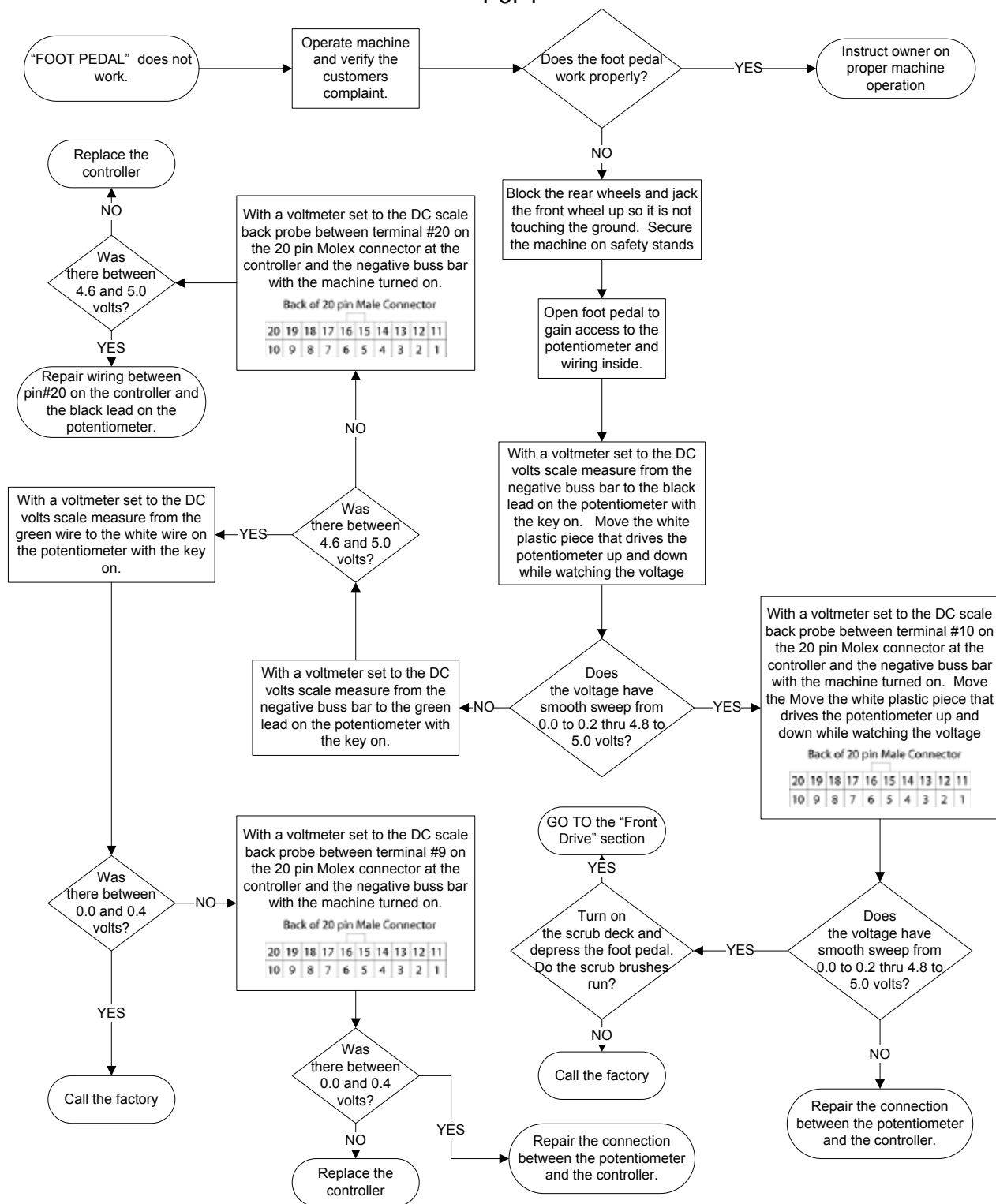

MODEL 250/GTX HEADLIGHT DIAGNOSTIC FLOW CHART 1 of 1

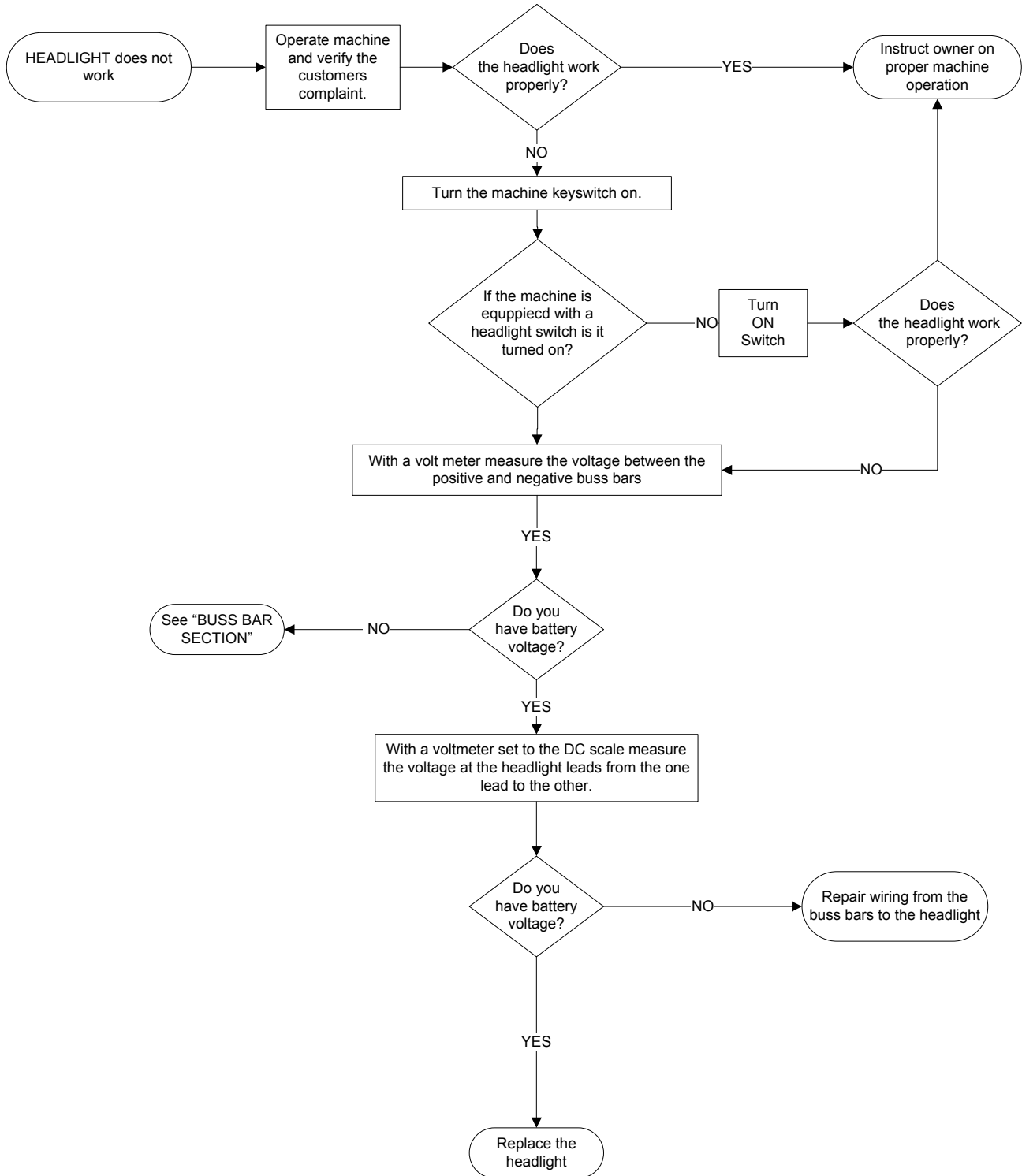

MODEL 250/GTX KEY SWITCH DIAGNOSTIC FLOW CHART
1 of 1

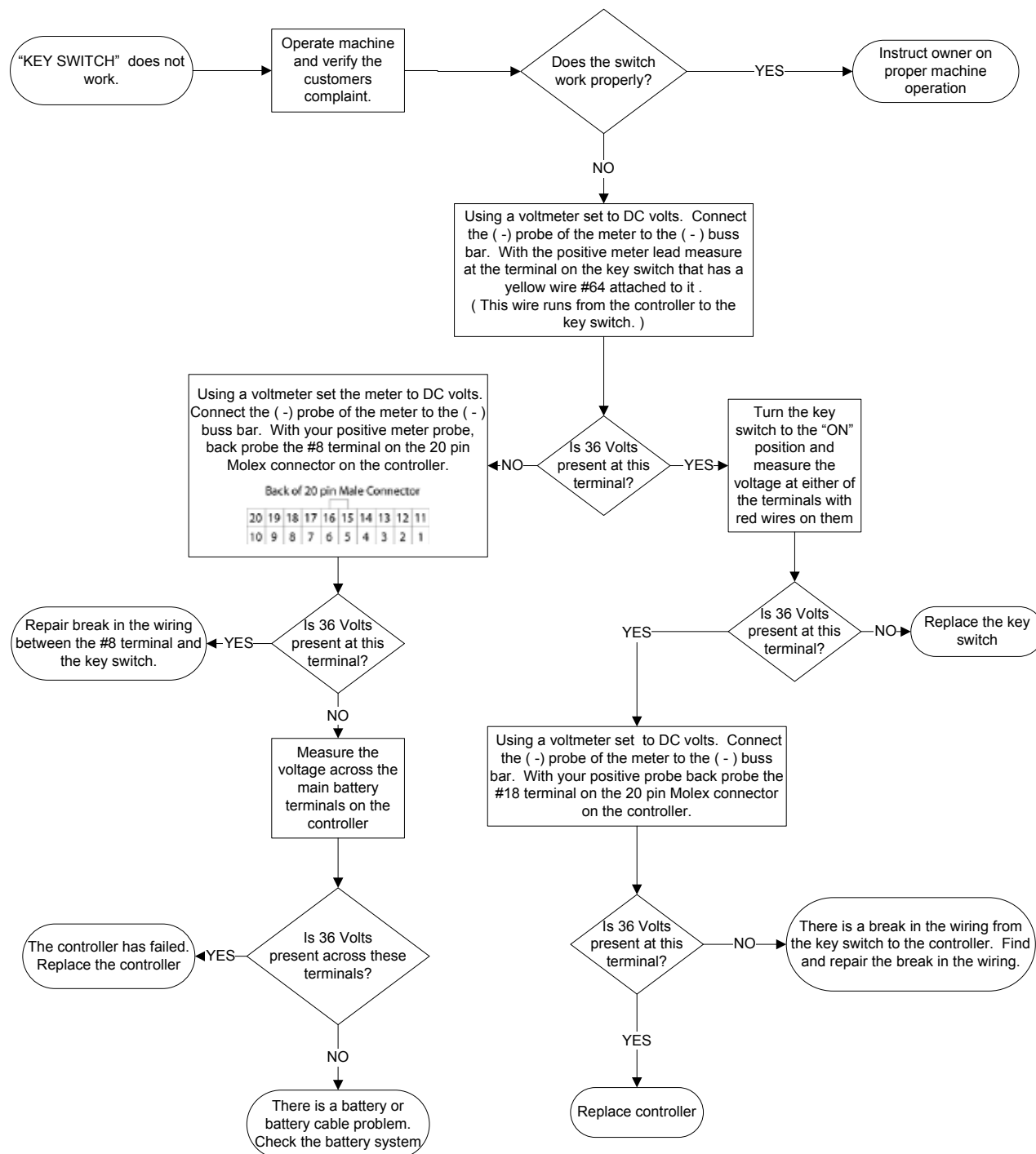

MODEL 250/GTX LCD WINDOW DIAGNOSTIC FLOW CHART 1 of 1

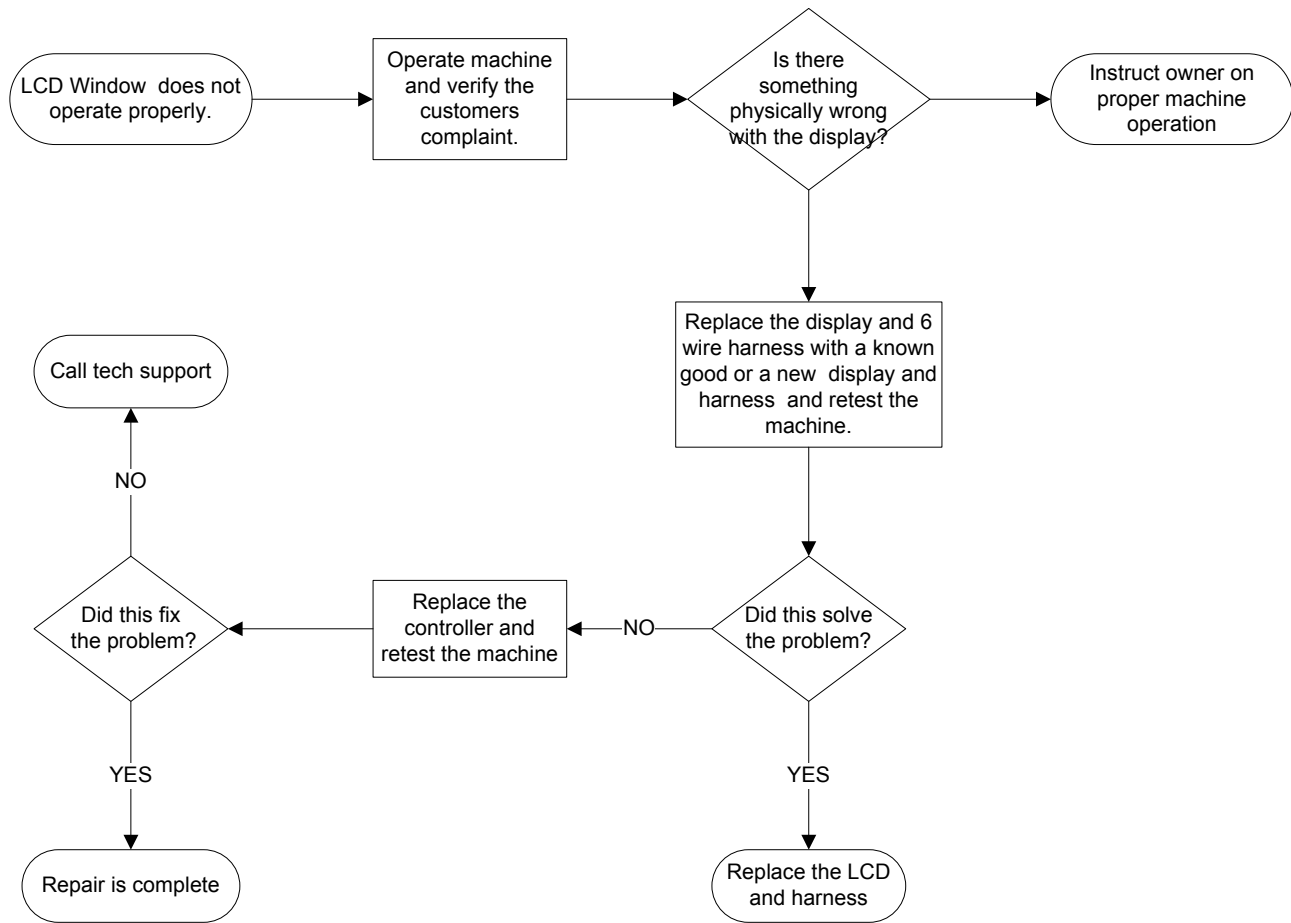

MODEL 250/GTX OFF BOARD VACUUM SWITCH DIAGNOSTIC FLOW CHART
1 of 1

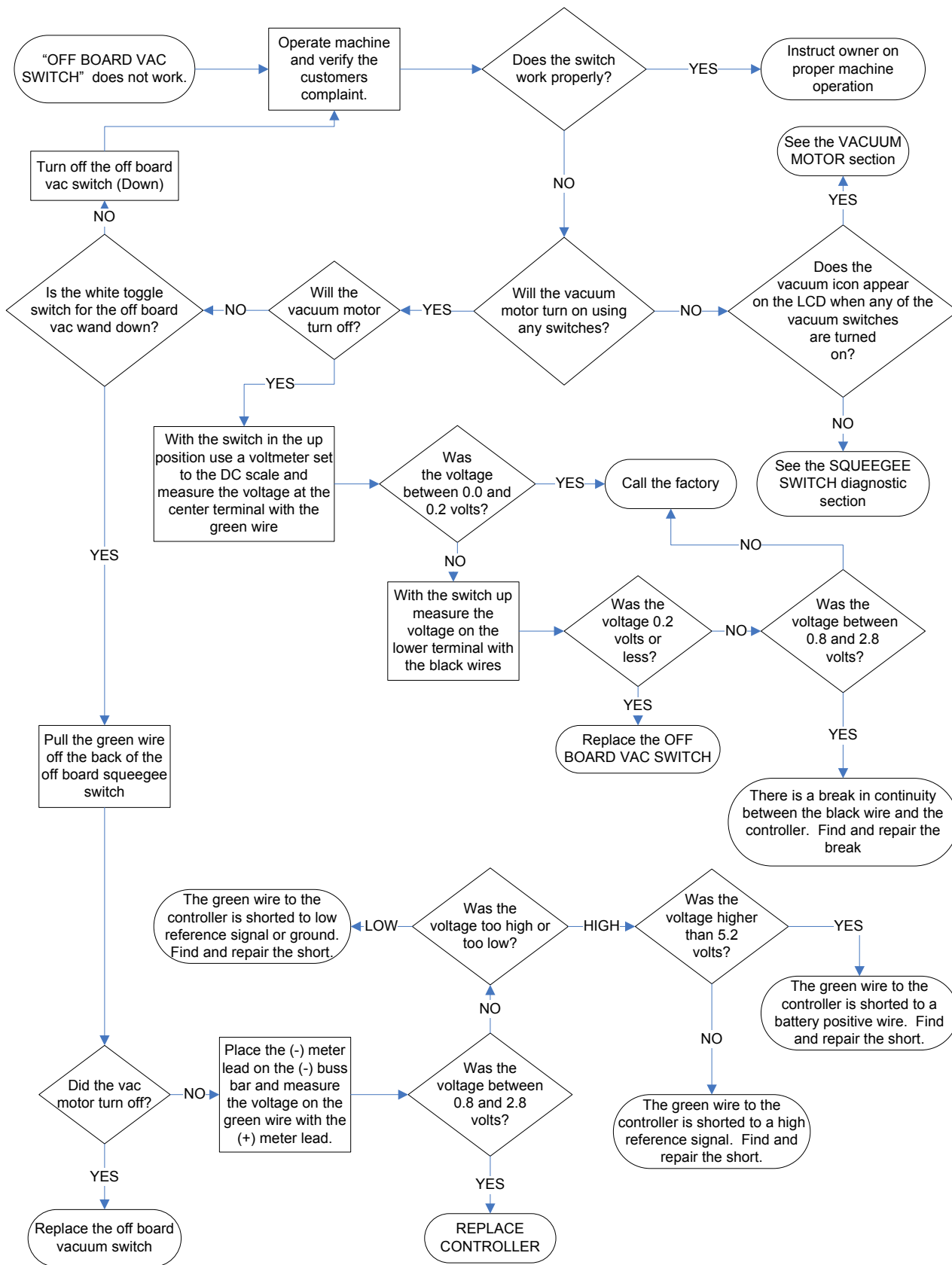

MODEL 250/GTX ONBOARD CHARGER DIAGNOSTIC FLOW CHART 1 of 1

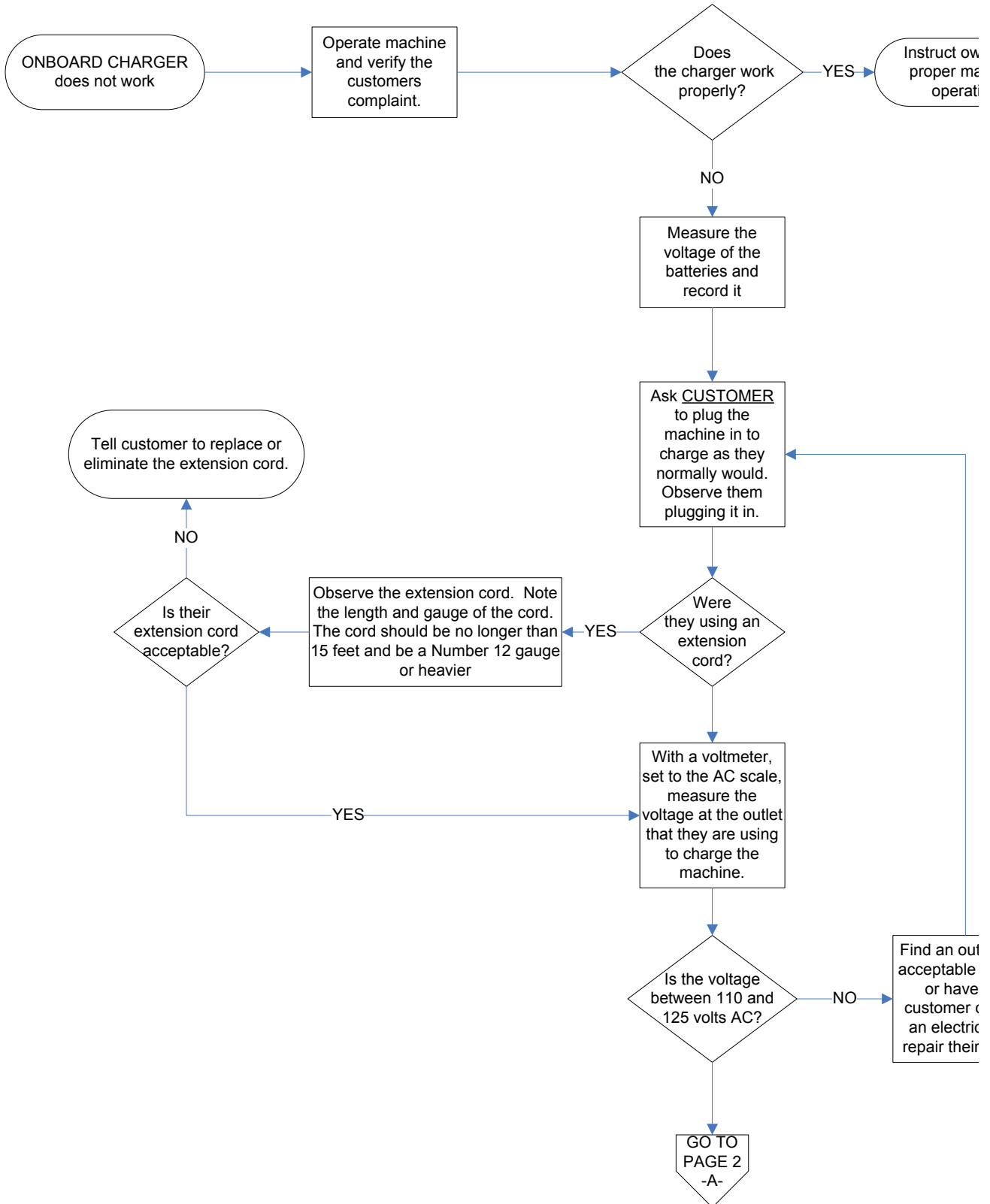

MODEL 250/GTX ONE TOUCH SWITCH DIAGNOSTIC FLOW CHART
1 of 1

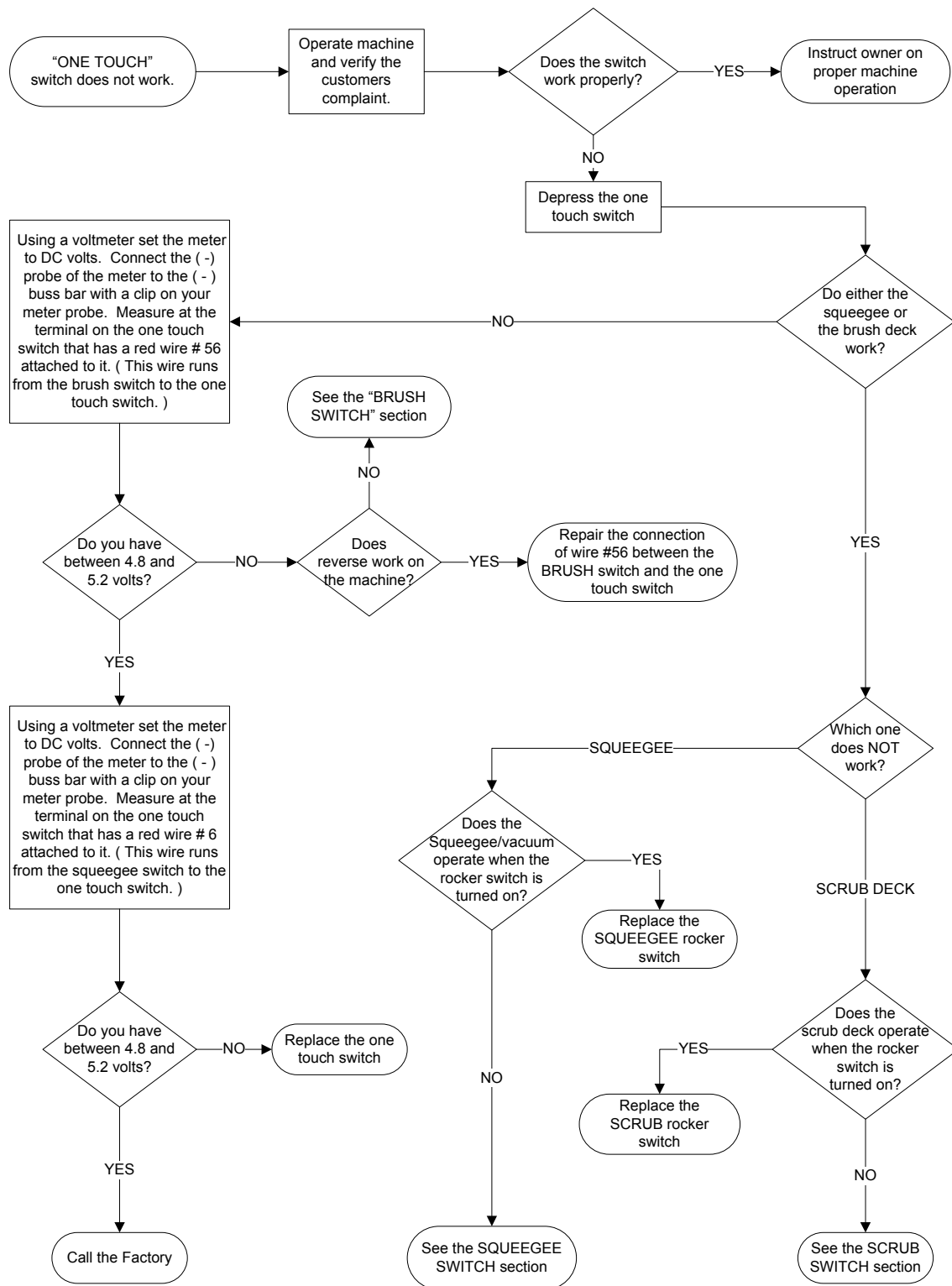

MODEL 250/GTX PARKING BRAKE DIAGNOSTIC FLOW CHART

1 of 1

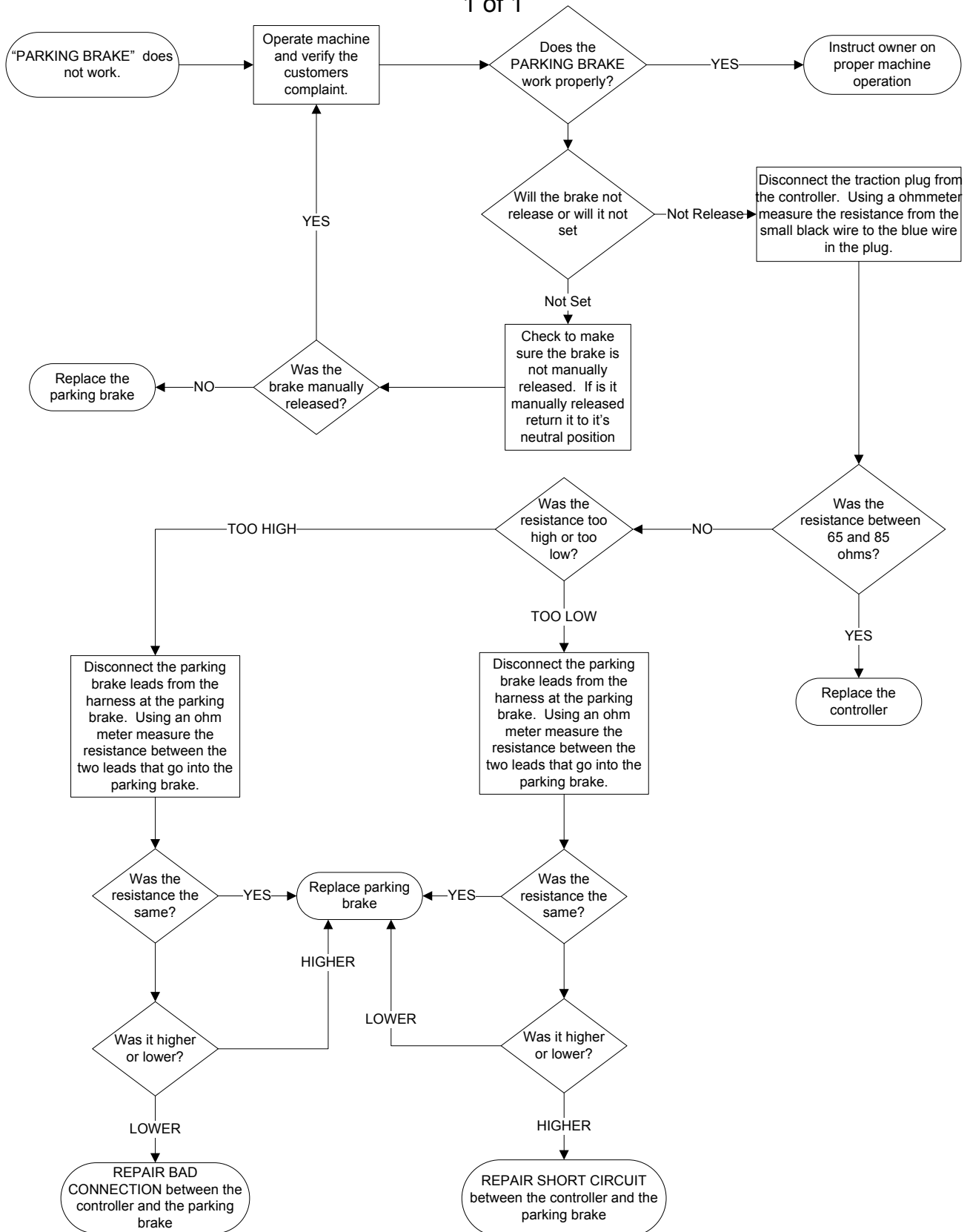

MODEL 250/GTX RECOVERY ALARM DIAGNOSTIC FLOW CHART

1 of 2

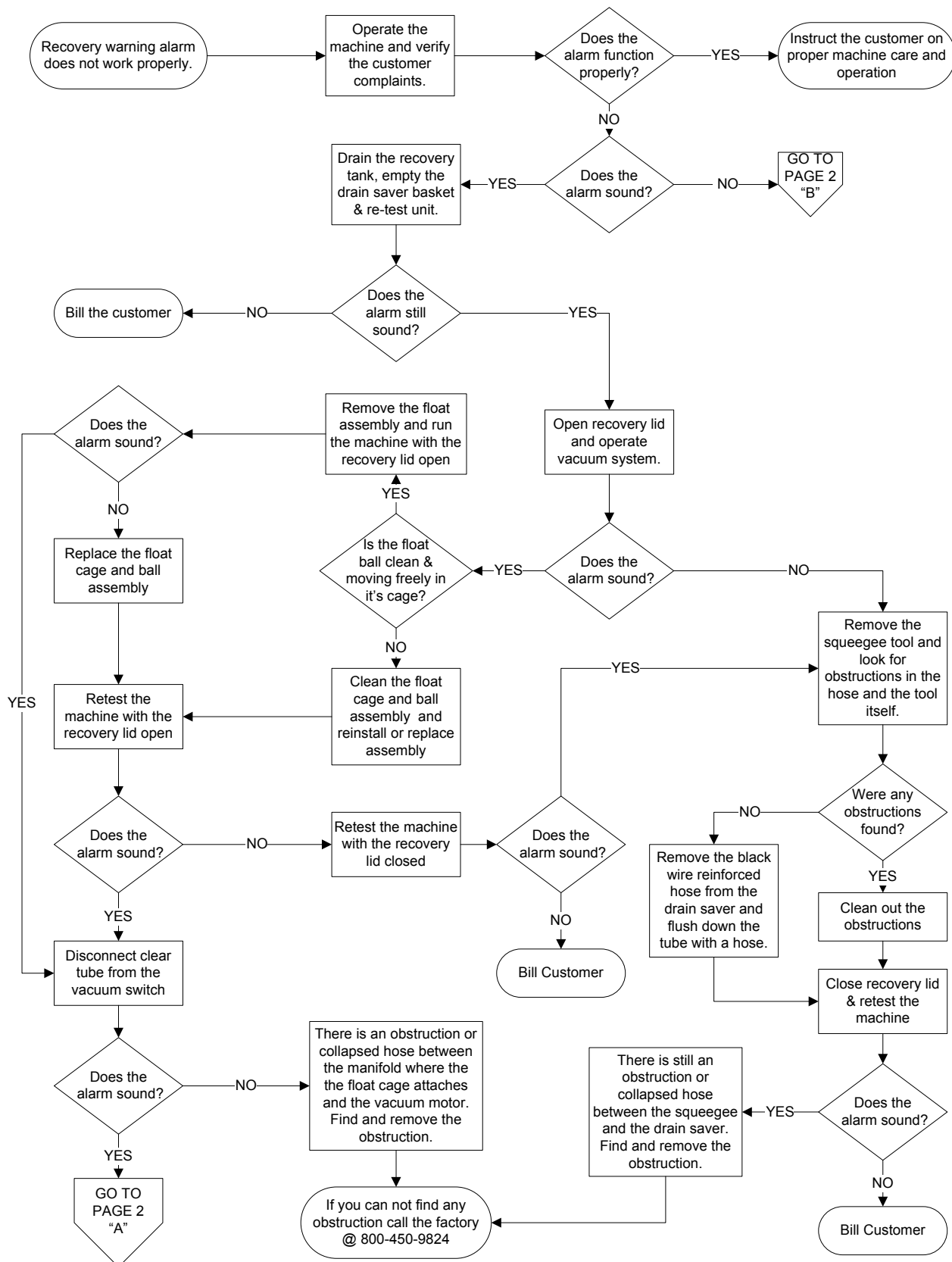

MODEL 250/GTX RECOVERY ALARM DIAGNOSTIC FLOW CHART
2 of 2

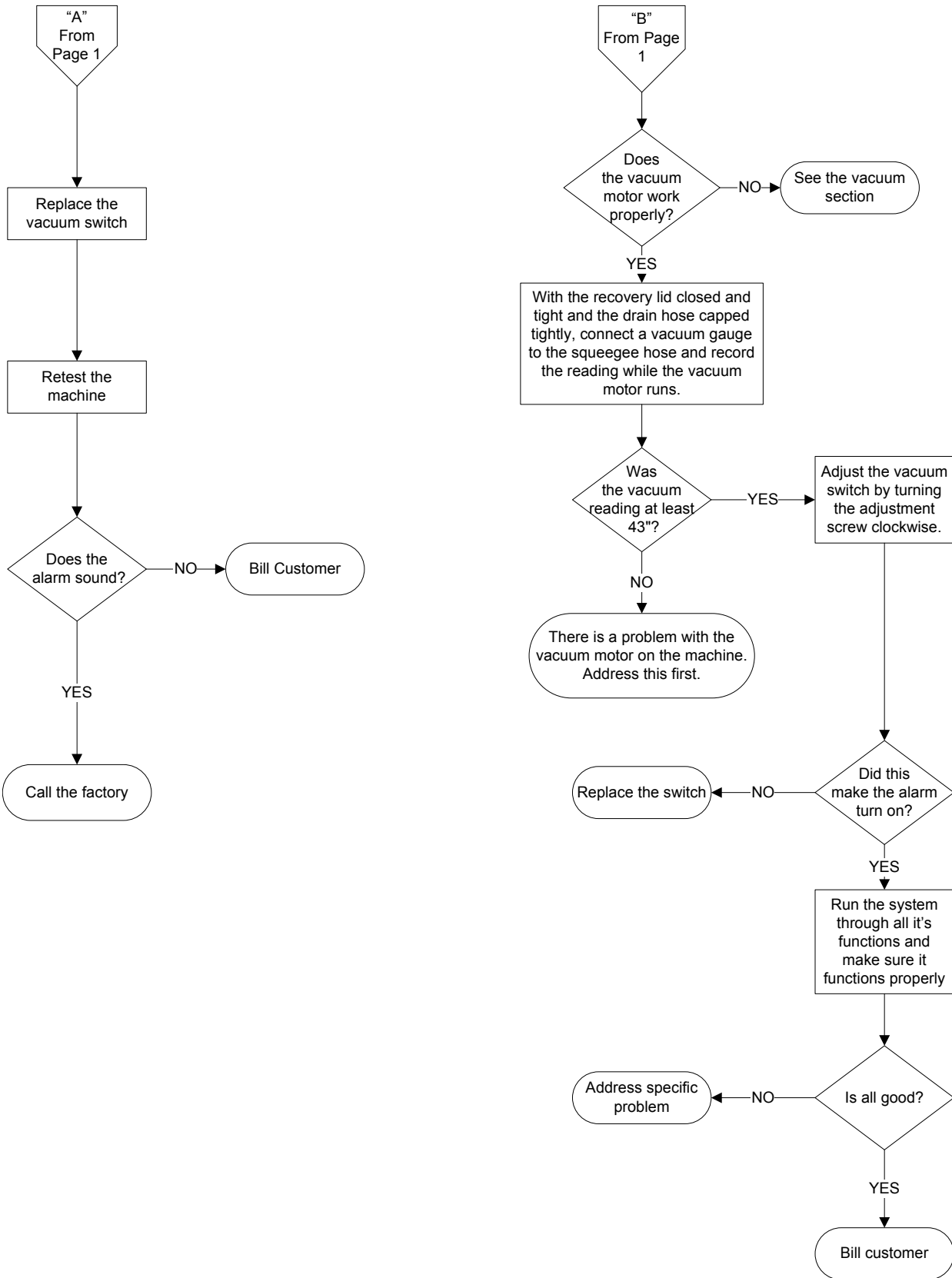

MODEL 250/GTX REVERSE SWITCH DIAGNOSTIC FLOW CHART

1 of 2

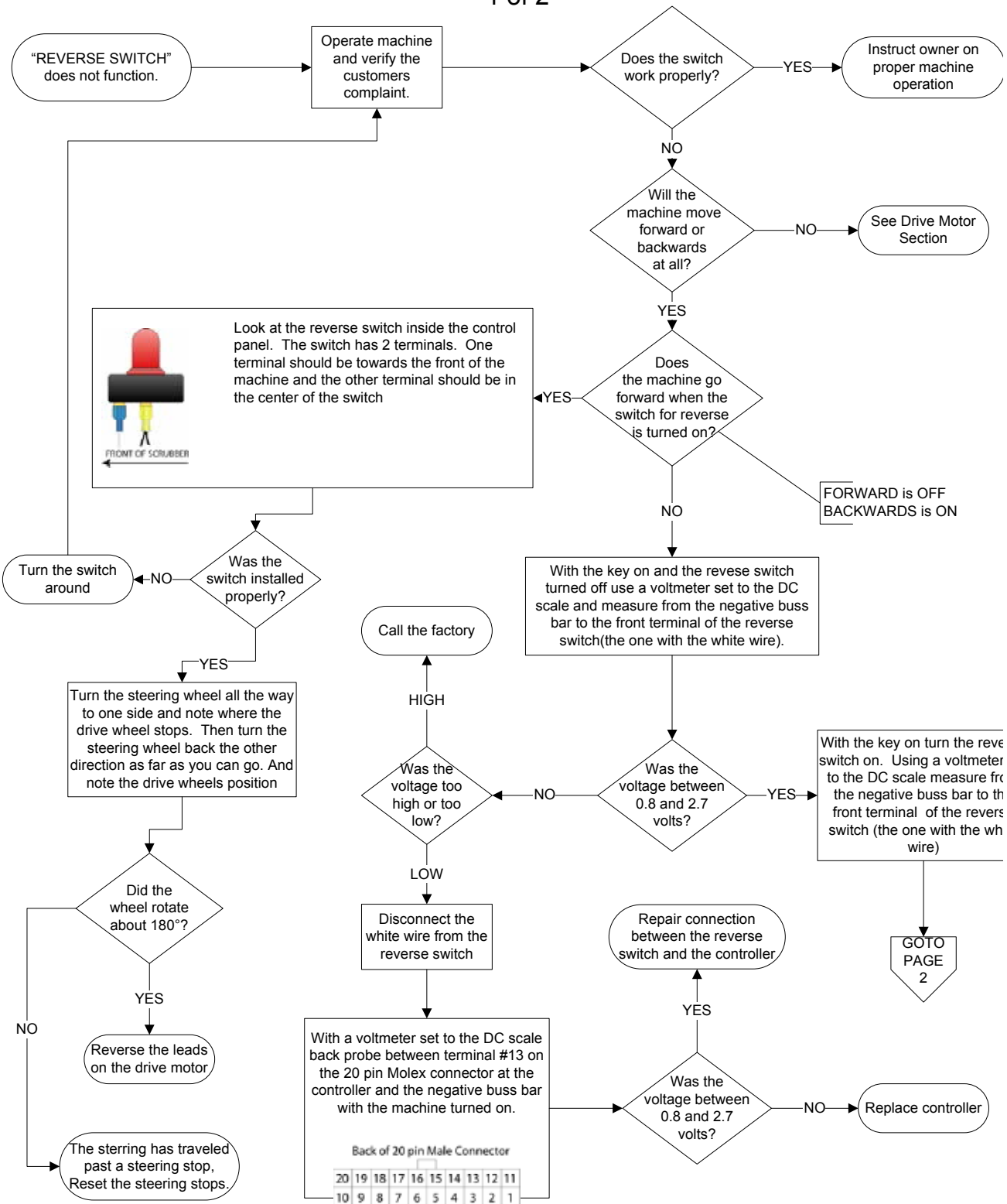

MODEL 250/GTX SCRUB MOTOR DIAGNOSTIC FLOW CHART
1 of 1

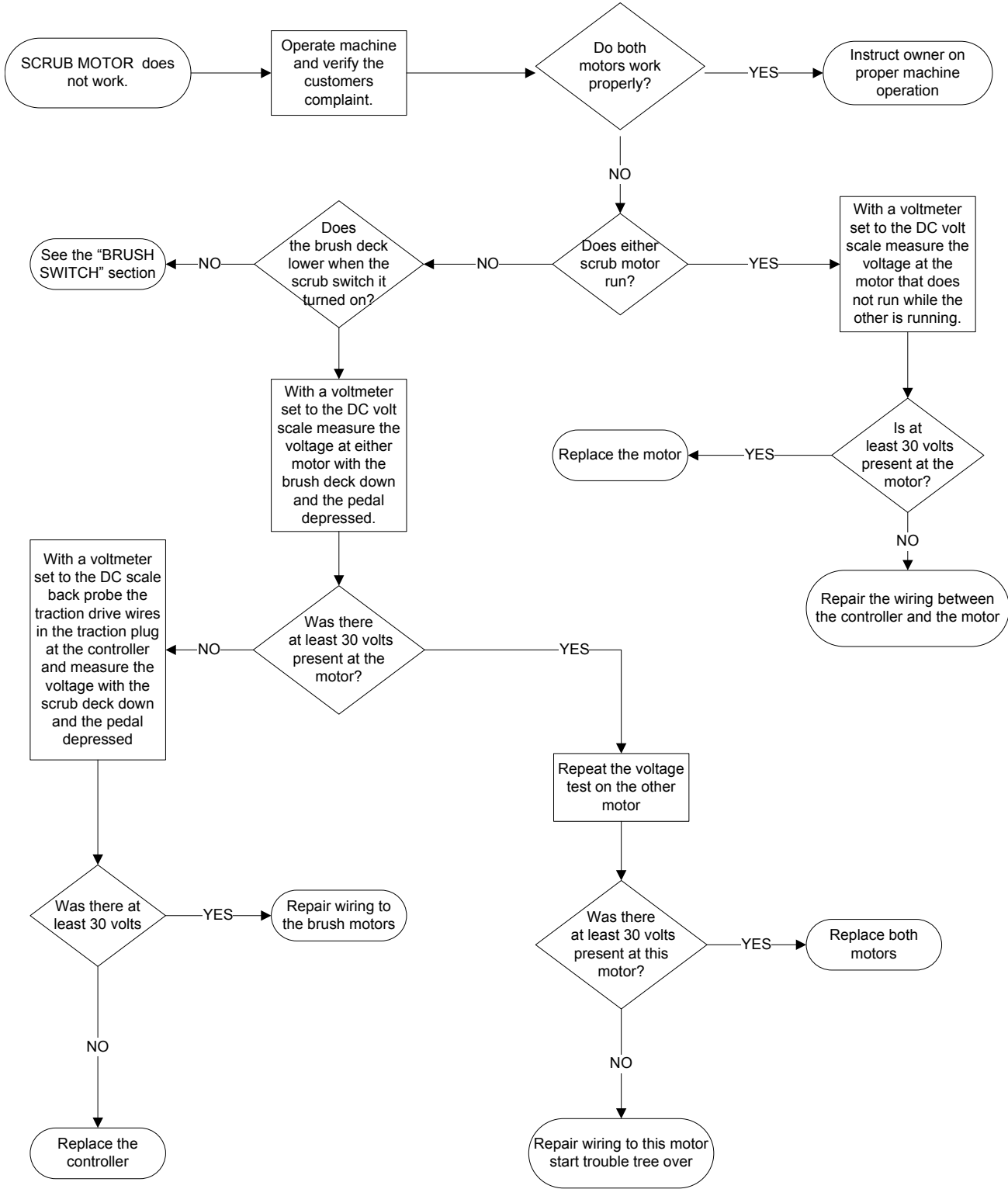

MODEL 250 SEAT SWITCH DIAGNOSTIC FLOW CHART 1 of 1

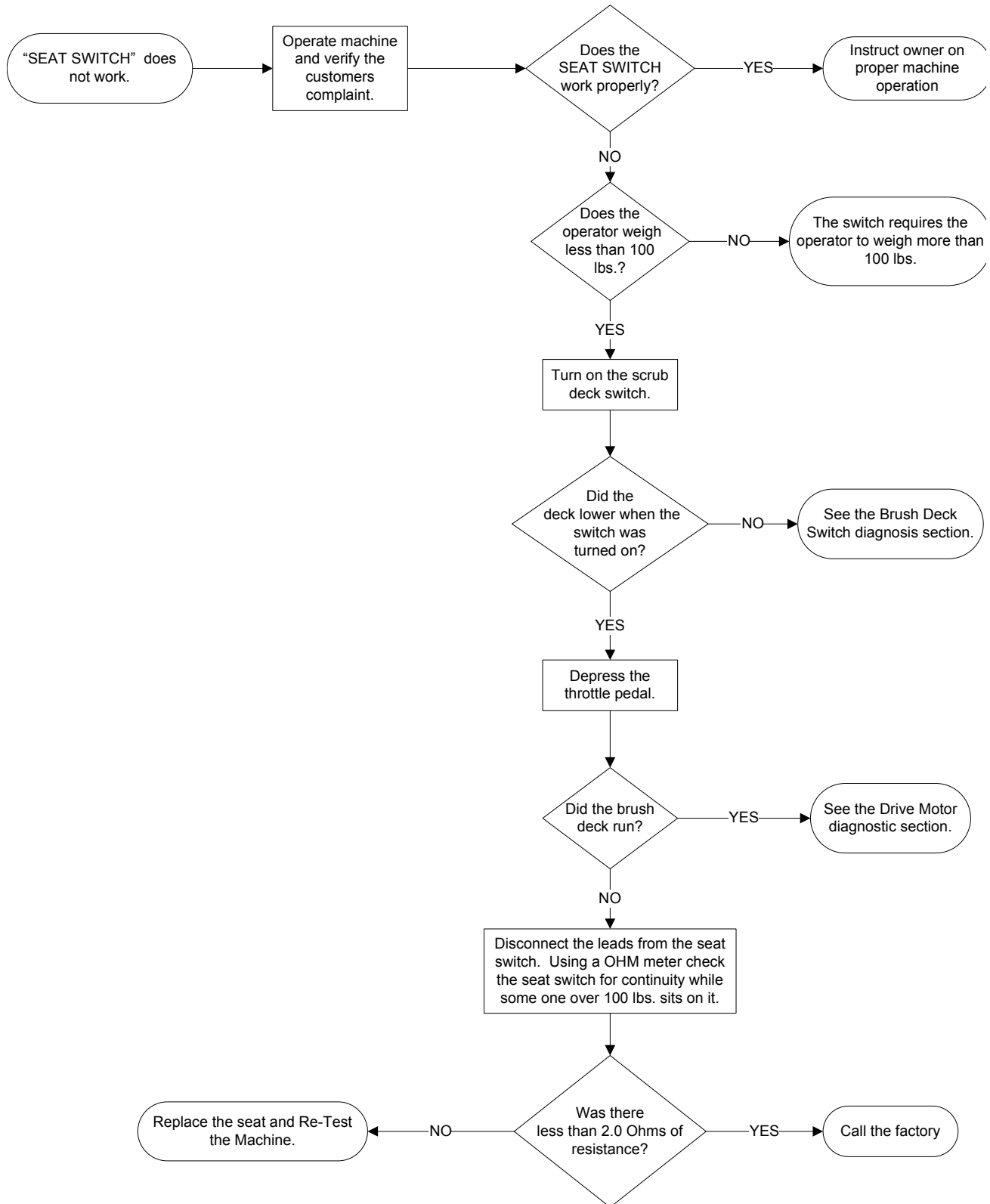

MODEL 250/GTX SIDE BROOM SWITCH DIAGNOSTIC FLOW CHART
1 of 1

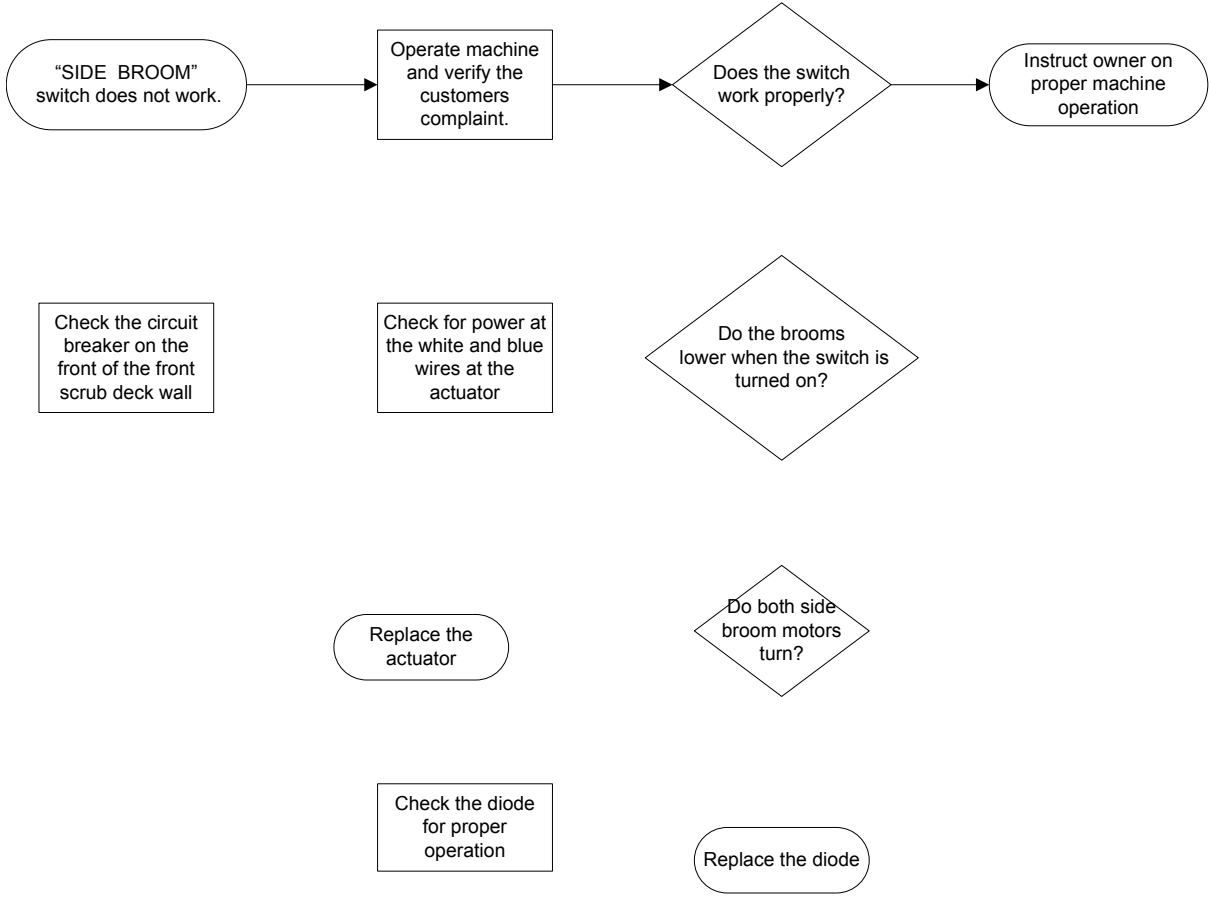

MODEL 250/GTX SPRAY JET DIAGNOSTIC FLOW CHART 1 of 2

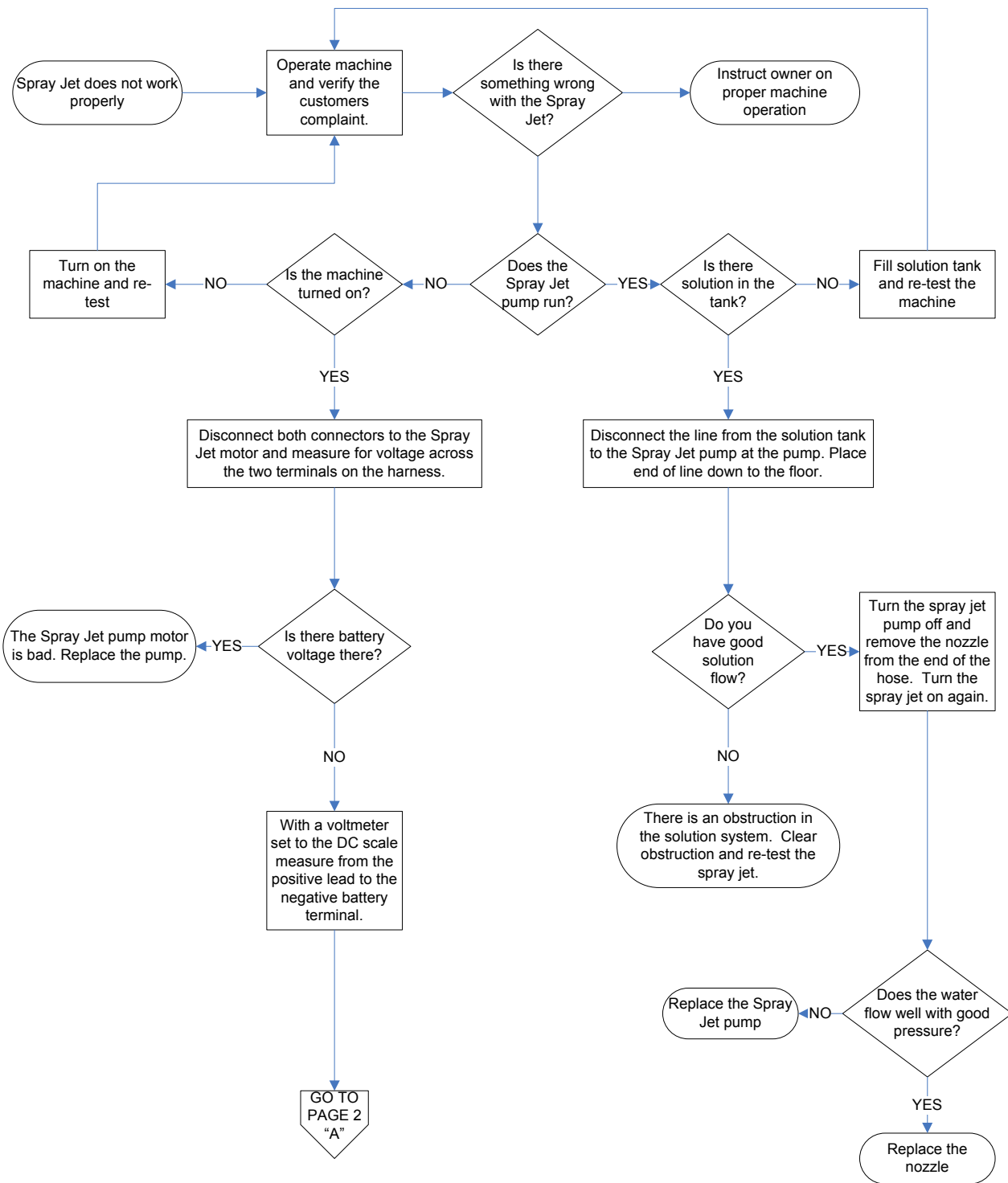

MODEL 250/GTX SPRAY JET DIAGNOSTIC FLOW CHART
2 of 2

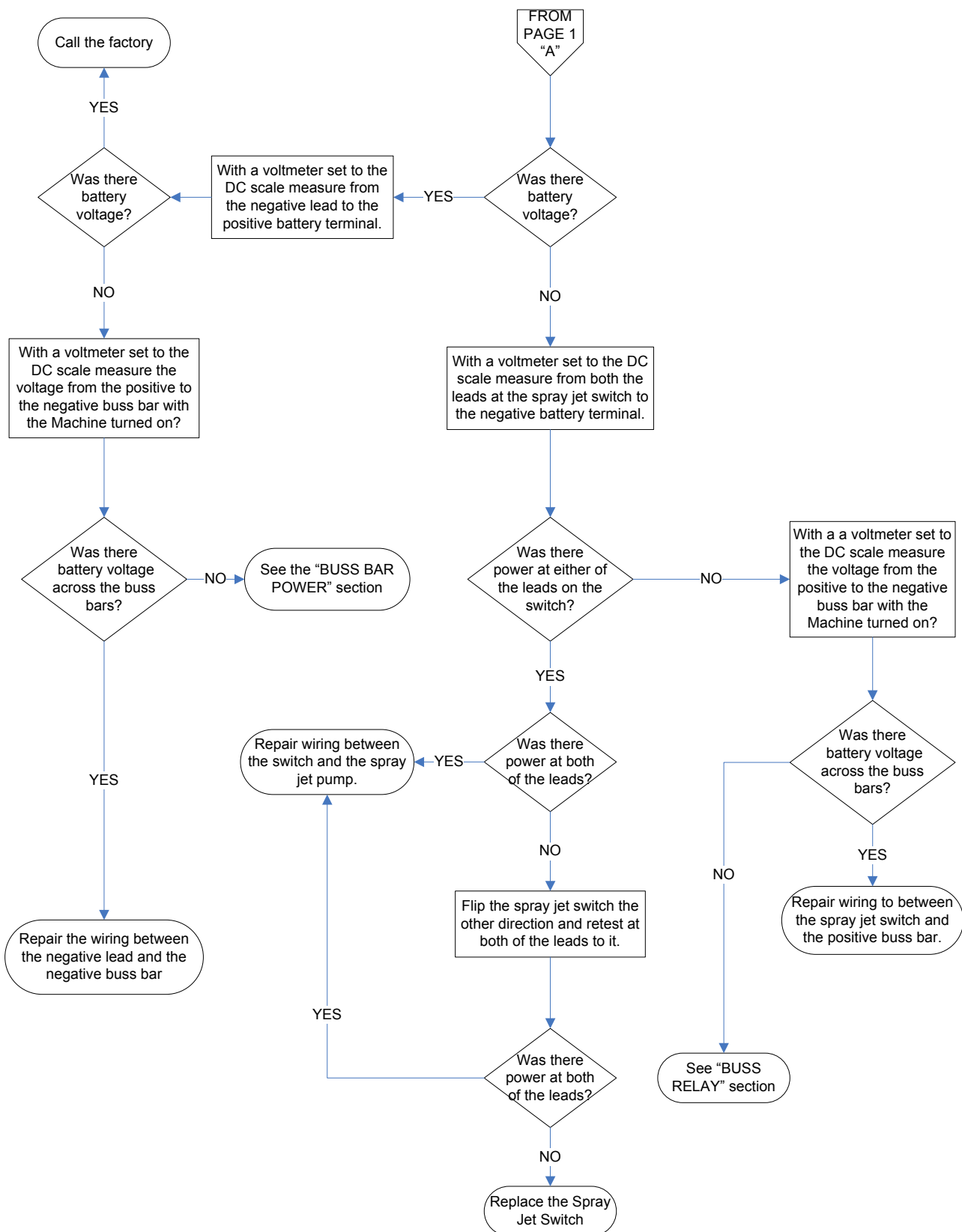

MODEL 250/GTX SQUEEGEE ACTUATOR DIAGNOSTIC FLOW CHART

1 of 1

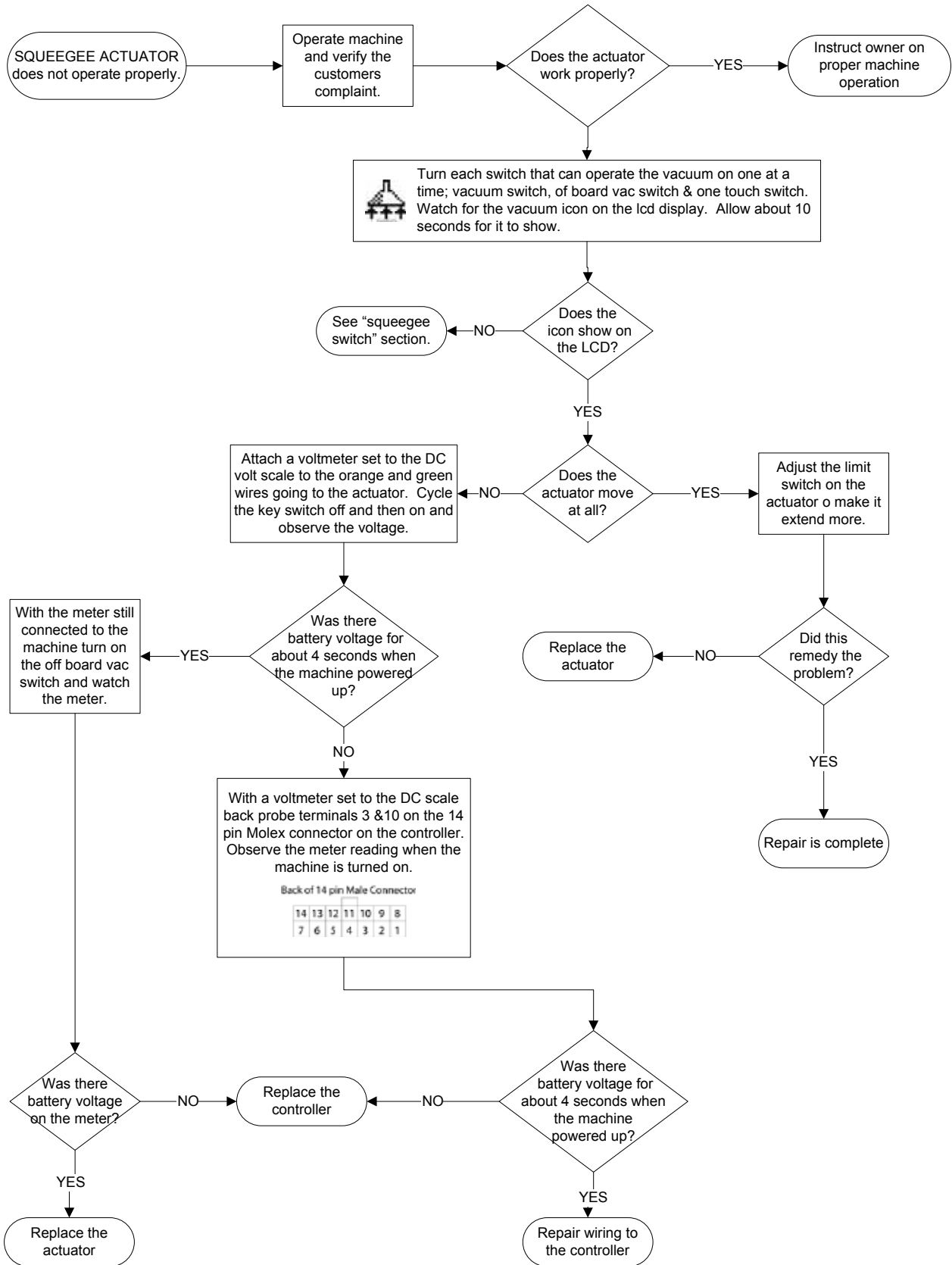

MODEL 250/GTX SQUEEGEE SWITCH DIAGNOSTIC FLOW CHART

1 of 3

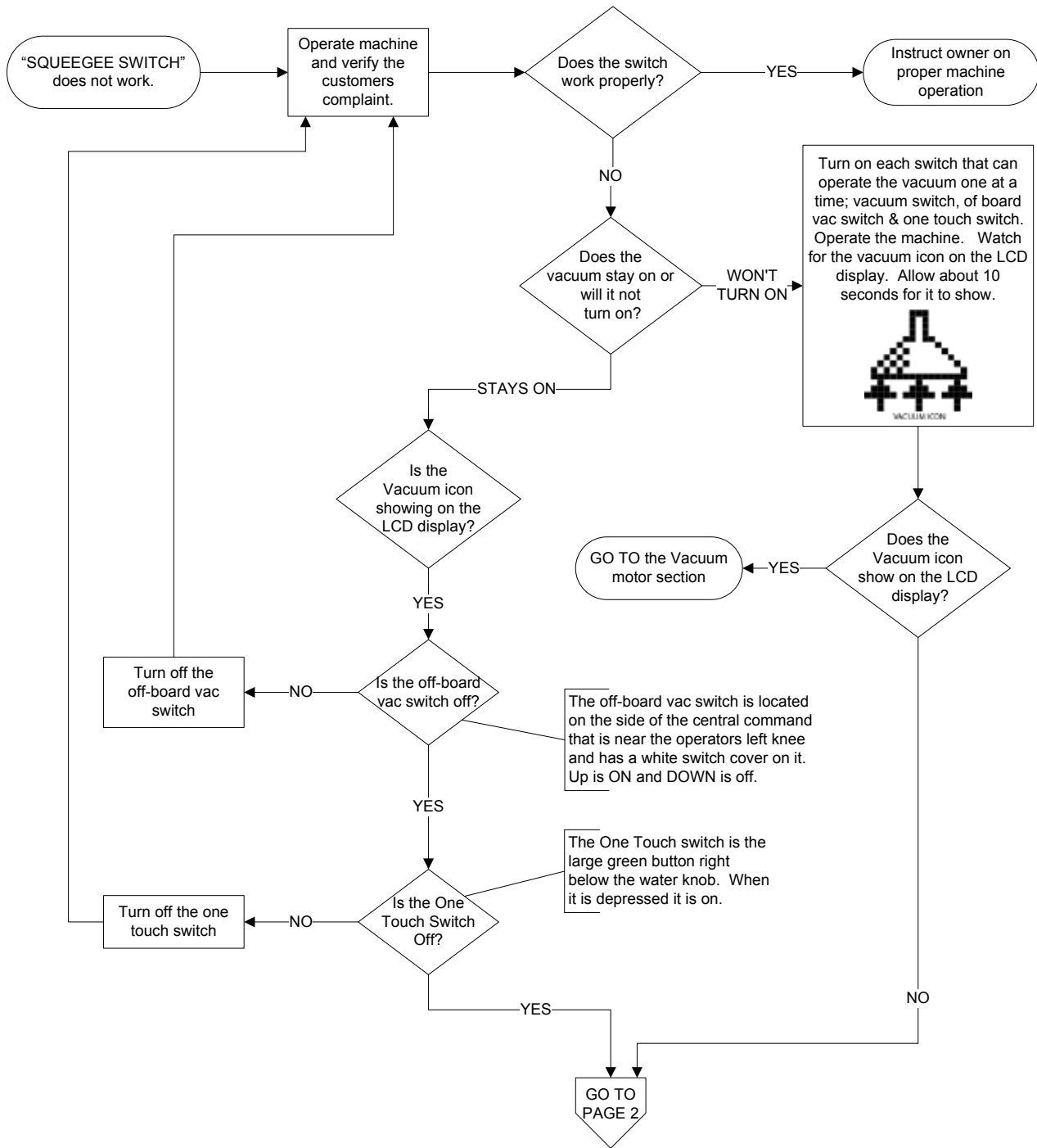

MODEL 250/GTX SQUEEGEE SWITCH DIAGNOSTIC FLOW CHART 2 of 3

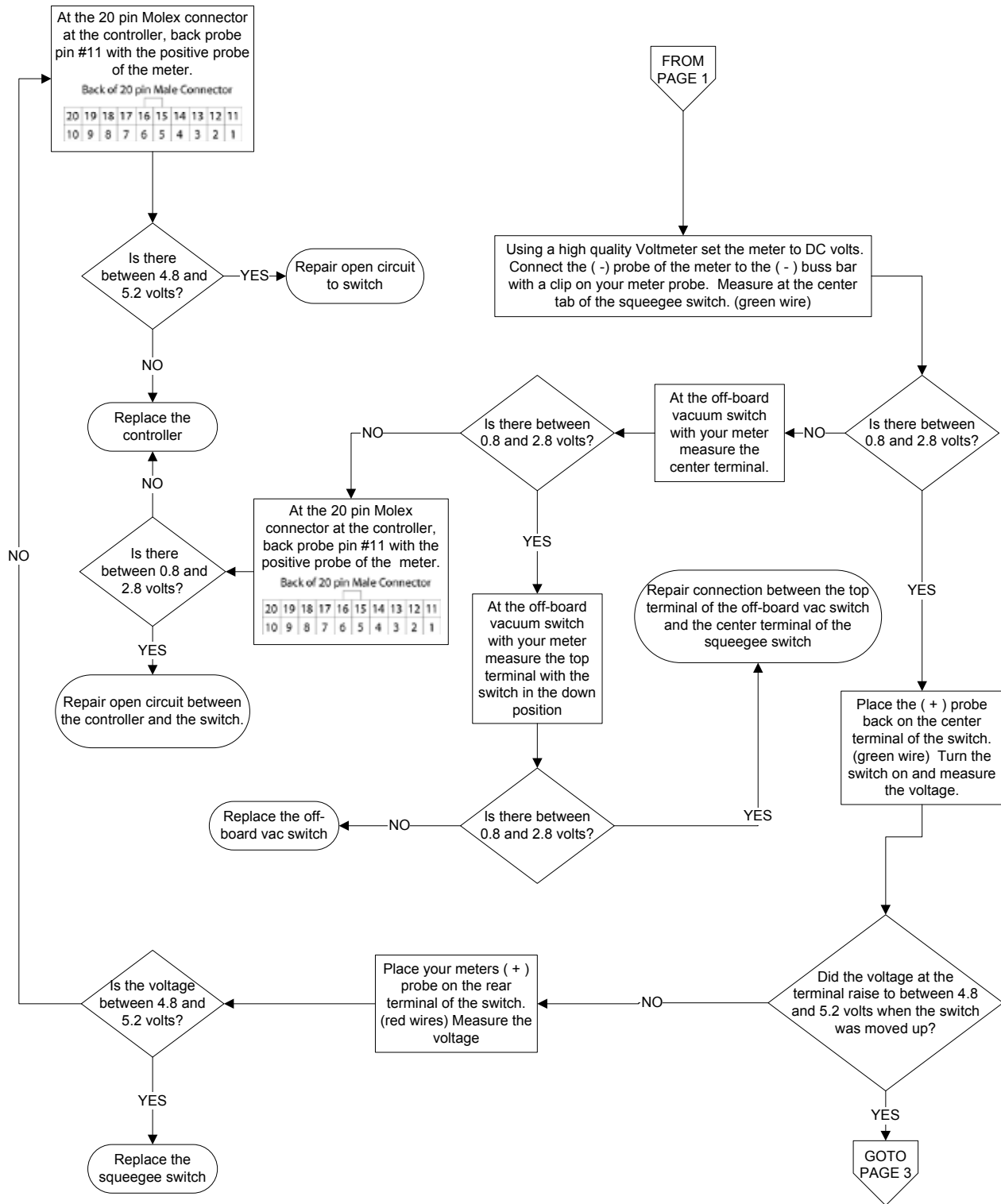

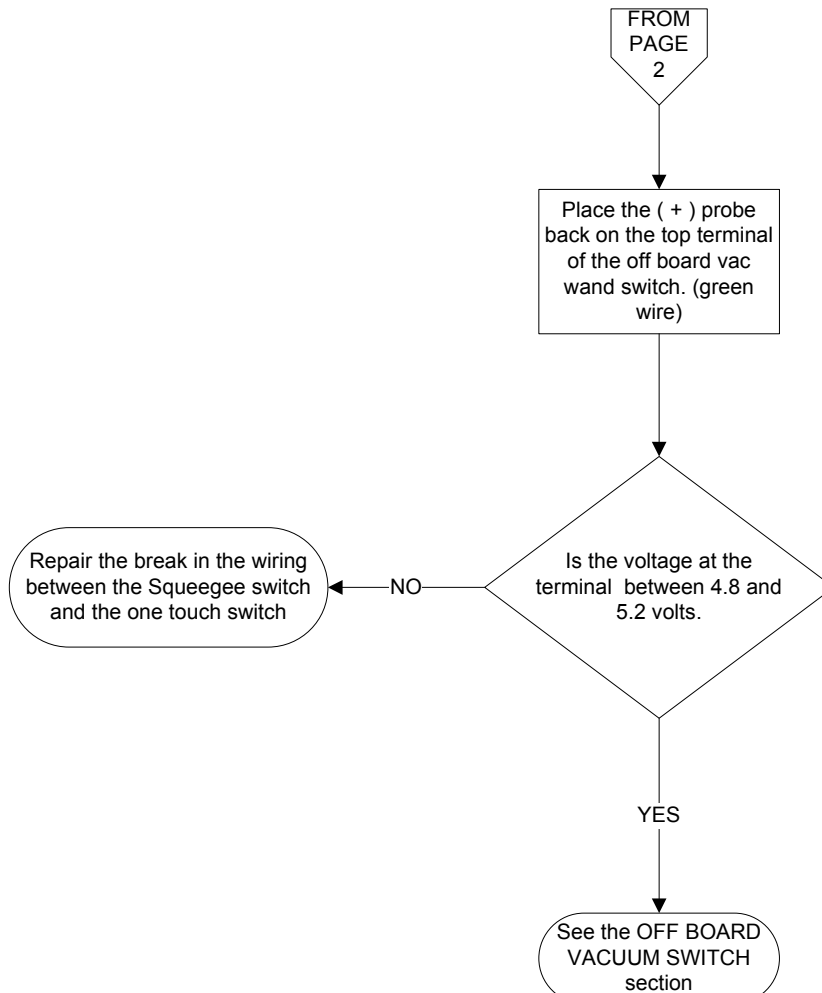
MODEL 250/GTX SQUEEGEE SWITCH DIAGNOSTIC FLOW CHART
3 of 3

MODEL 250/GTX VACUUM MOTOR DIAGNOSTIC FLOW CHART

1 of 1

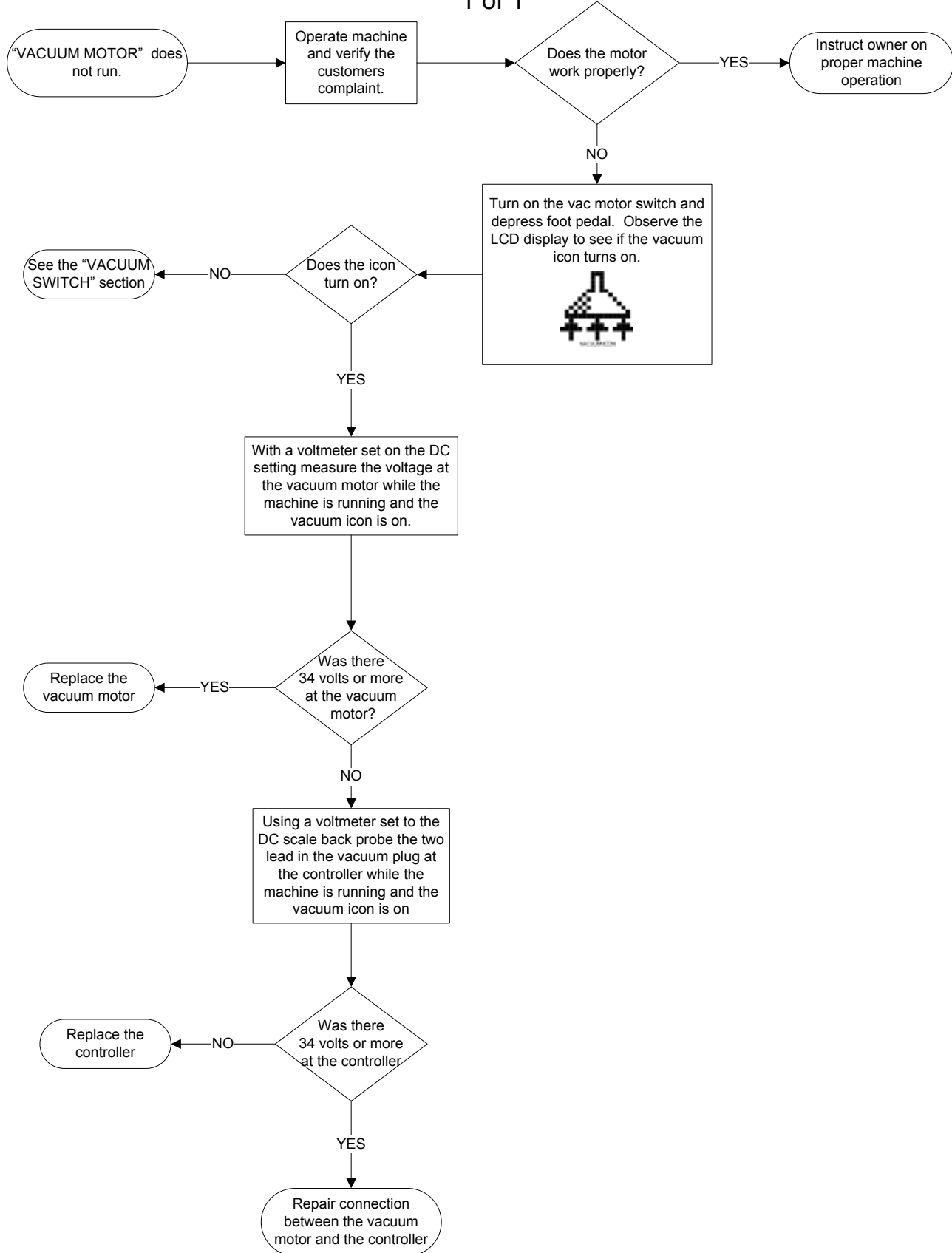

MODEL 250/GTX WATER POTENTIOMETER DIAGNOSTIC FLOW CHART
1 of 3

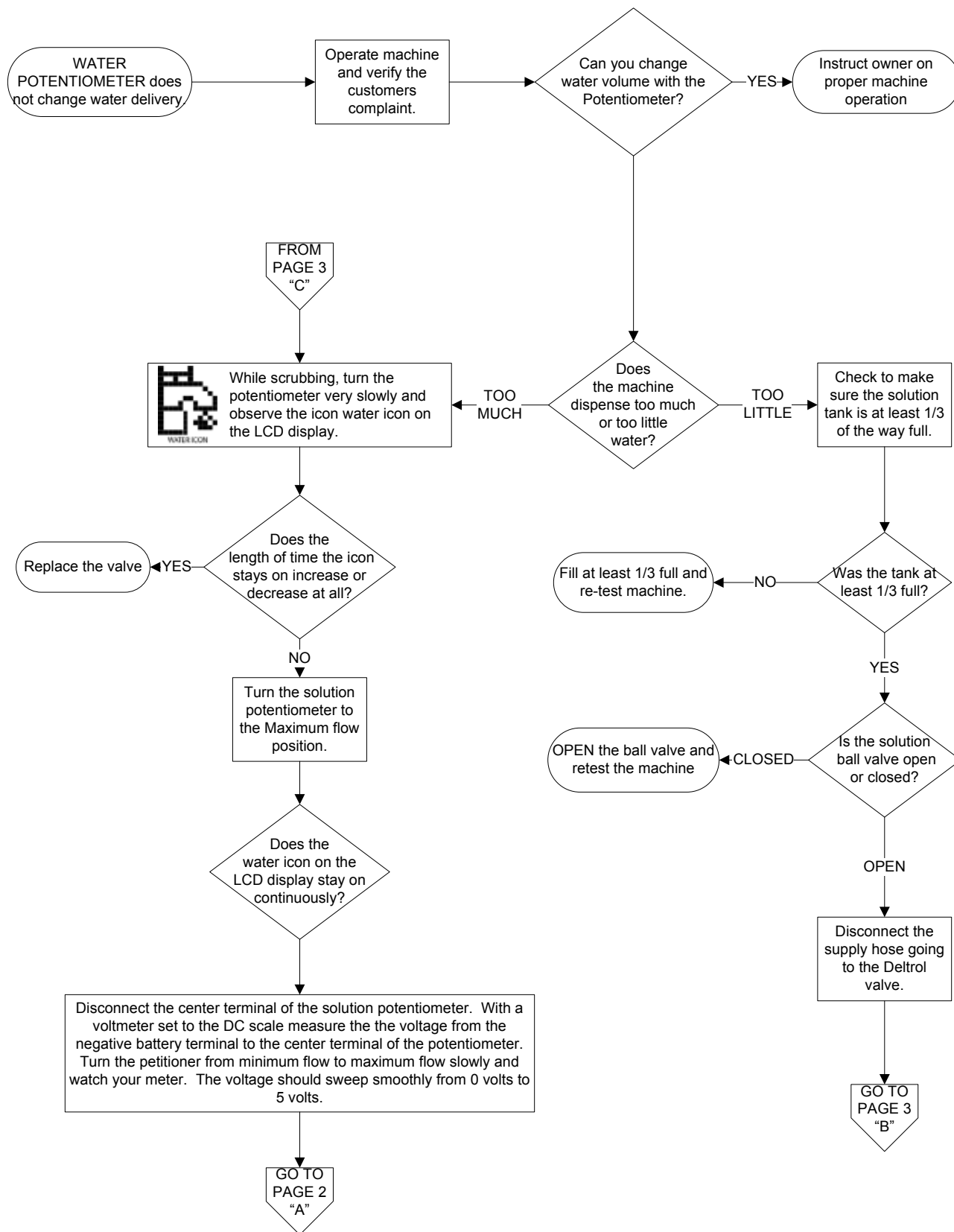

MODEL 250/GTX WATER POTENTIOMETER DIAGNOSTIC FLOW CHART 2 of 3

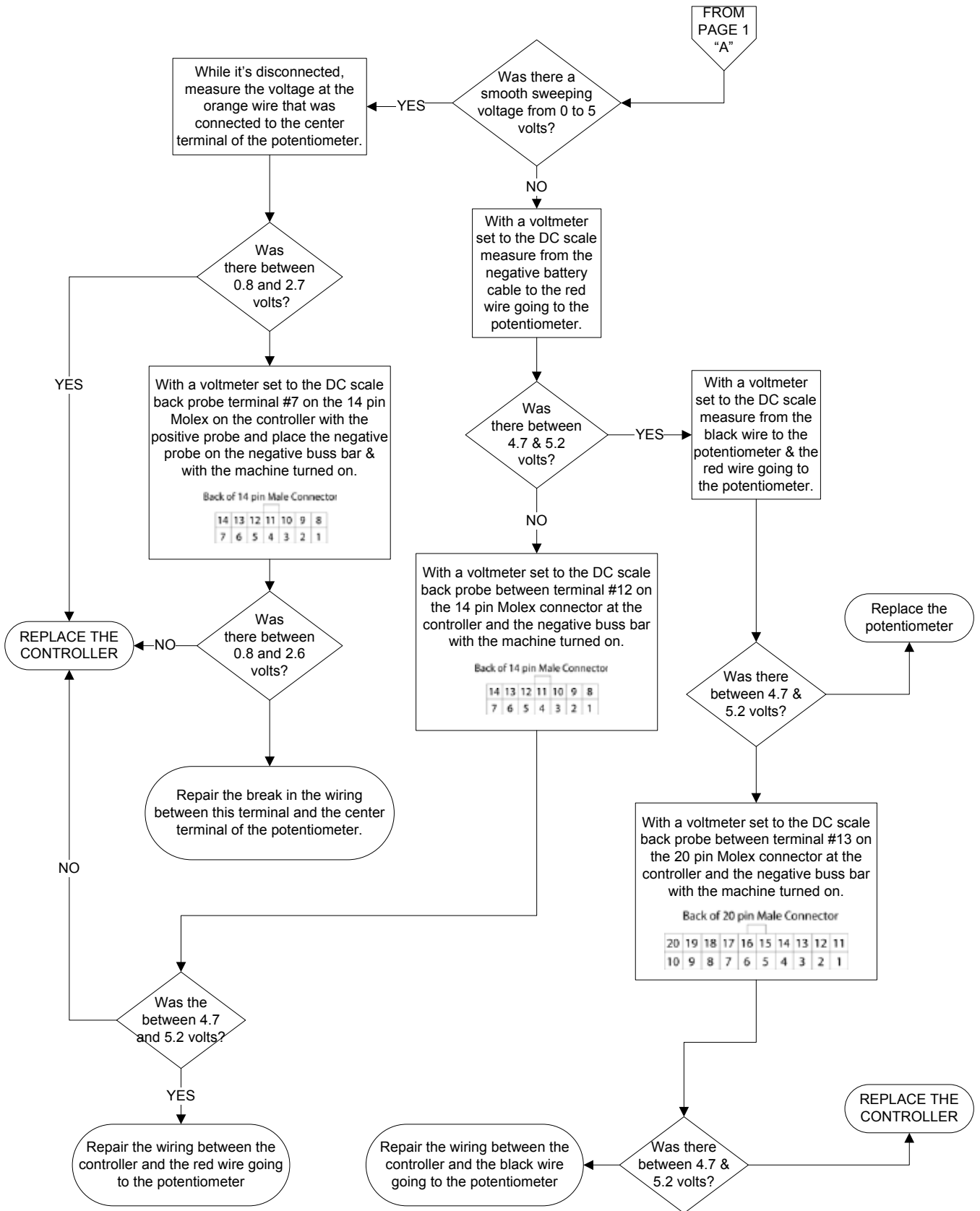

MODEL 250/GTX WATER POTENTIOMETER DIAGNOSTIC FLOW CHART
3 of 3

