

200 BURNISHER

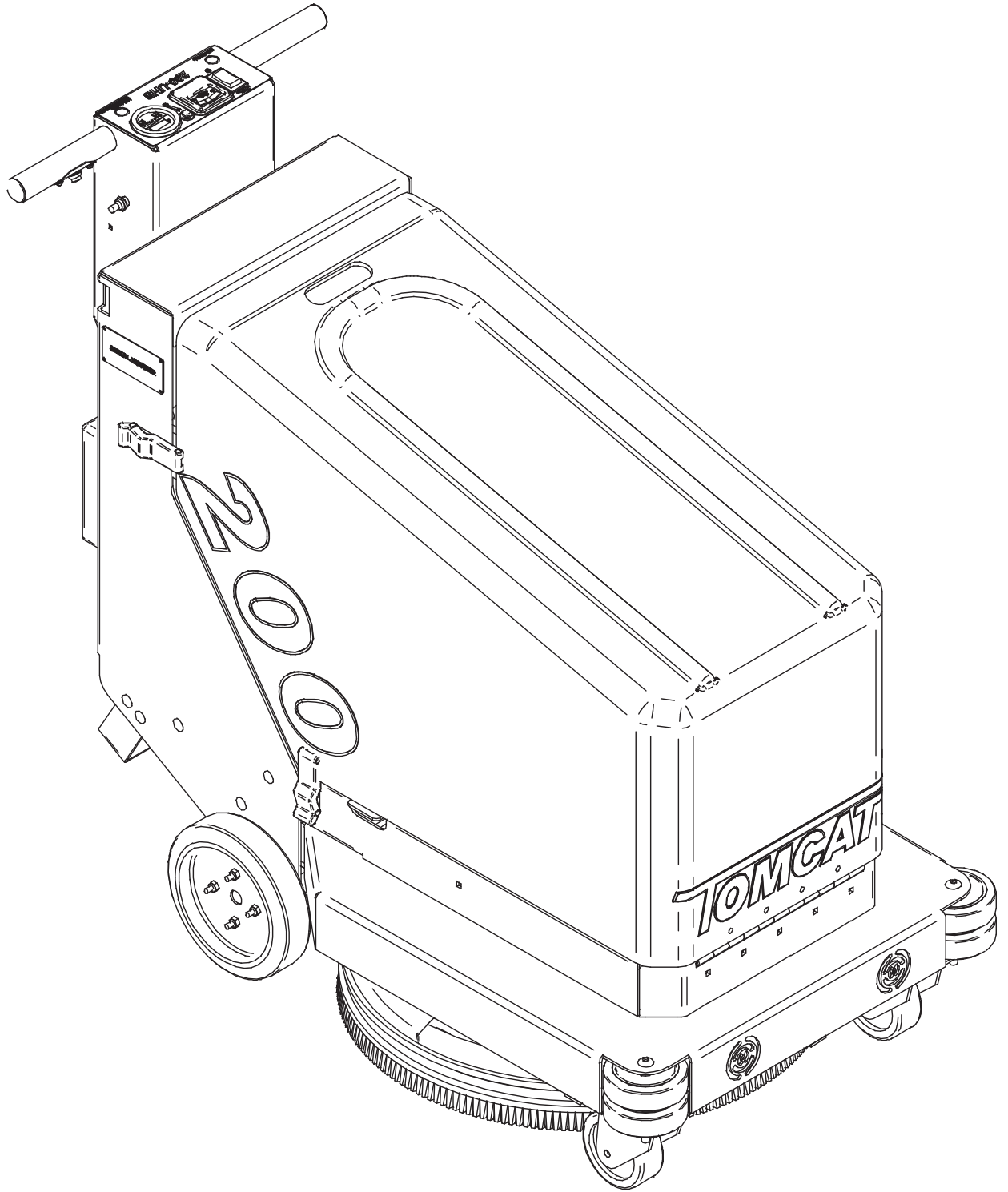

R.P.S. Corporation
Phone: 1-800-450-9824
P.O. Box 241
Racine, Wisconsin 53401

Casters and Upright.....	4
Deck and Actuator	6
Actuator Slide	7
Burnisher Deck.....	8
Transaxle and Central Command.....	10
Central Command	12
Batteries and Charger	14
Pad Assist.....	16
Common wear parts	18
Suggested parts inventory.....	19

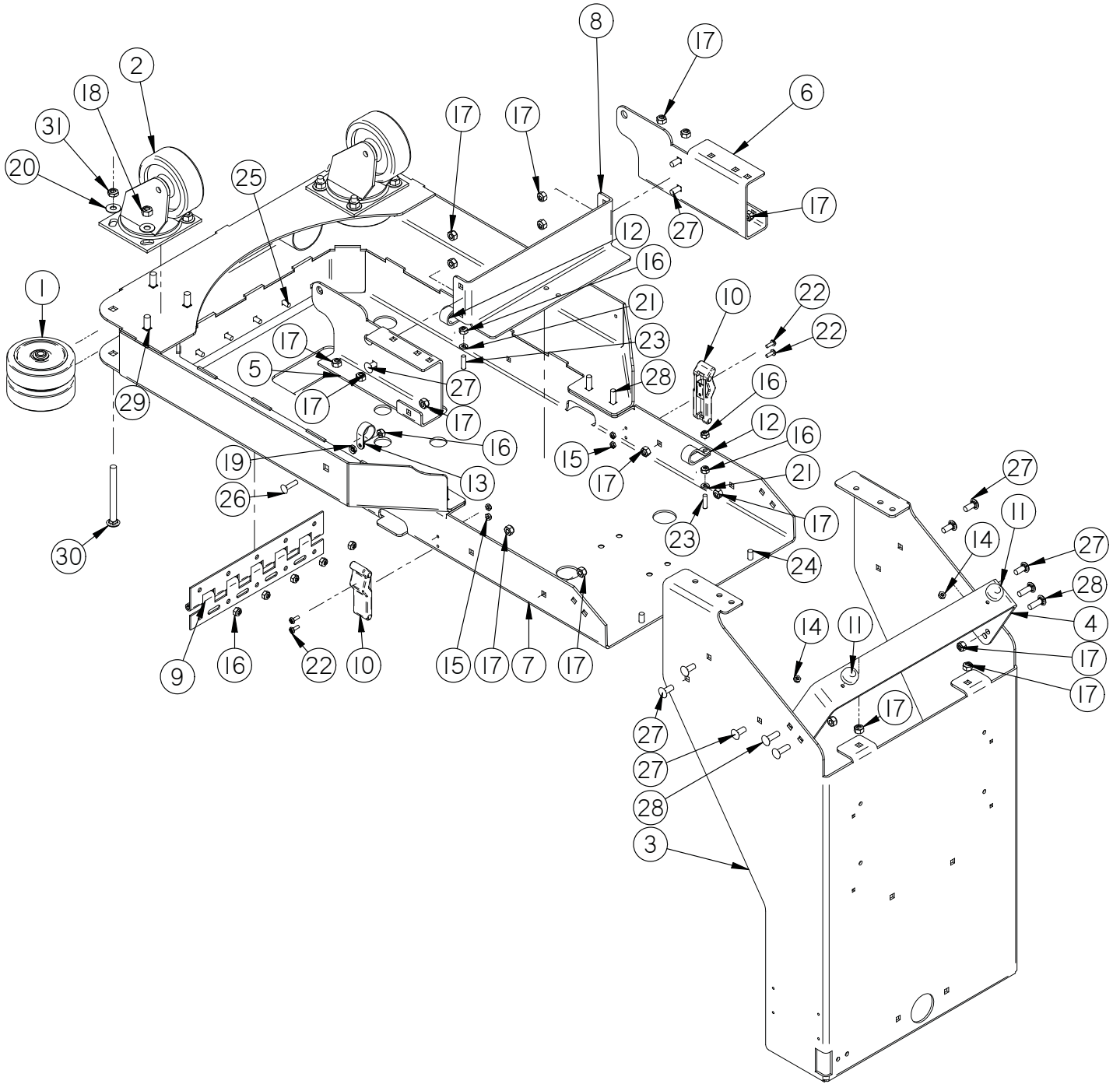

Item	Part No.	Part Description	Qty.
1	190-3030	4.0" WHEEL (GRAY)	4
2	190-3035	CASTER, NON-MARKING (RED)	2
3	200-1002	REAR UPRIGHT	1
4	200-1005	SUPPORT ARM	1
5	200-1009	REAR SUPPORT BRACKET - RH	1
6	200-1010	REAR SUPPORT BRACKET - LH	1
7	200-2000	200 MAIN FRAME	1
8	200-2001	FRAME STIFFENER	1
9	370-1225	11" SS HINGE	1
10	4-124	LATCH	2
11	H-01201	GROMMET	2
12	H-0127294	RUBBER LOOP CLAMP, 3/4"	2
13	H-0127296	LOOP CLAMP, 1.0"	1
14	H-0129154	JAM NYLOK #10-24 SS	2
15	H-70856	NYLOK #8-32 SS	4
16	H-70860	NYLOK 1/4"- 20 SS	9
17	H-70861	NYLOK 5/16" - 18 SS	20
18	H-70862	NYLOK 3/8"-16 SS	6
19	H-70925	KN 1/4-20 S/S	1
20	H-71017	FW 3/8" X 7/8" SS	8
21	H-71063	LW 1/4" SS	2
22	H-72398	PPH #8-32 X 1/2" S/S	4
23	H-73883	FHSCS 1/4- 20 X 1.0" S/S	2
24	H-73907	FHSCS 5/16"- 18 X 3/4" SS	2
25	H-74418	CB 1/4"- 20 X 5/8" S/S	5
26	H-74420	CB 1/4"- 20 X 1.0" SS	1
27	H-74429	CB 5/16"- 18 X 3/4" SS	10
28	H-74430	CB 5/16"- 18 X 1" SS	8
29	H-74436	CB 3/8"- 16 X 1.0" SS	6
30	H-74443	CB 3/8"- 16 X 4.0" SS	2
31	H-NJ06C	JNYL 3/8- 16 SS	2

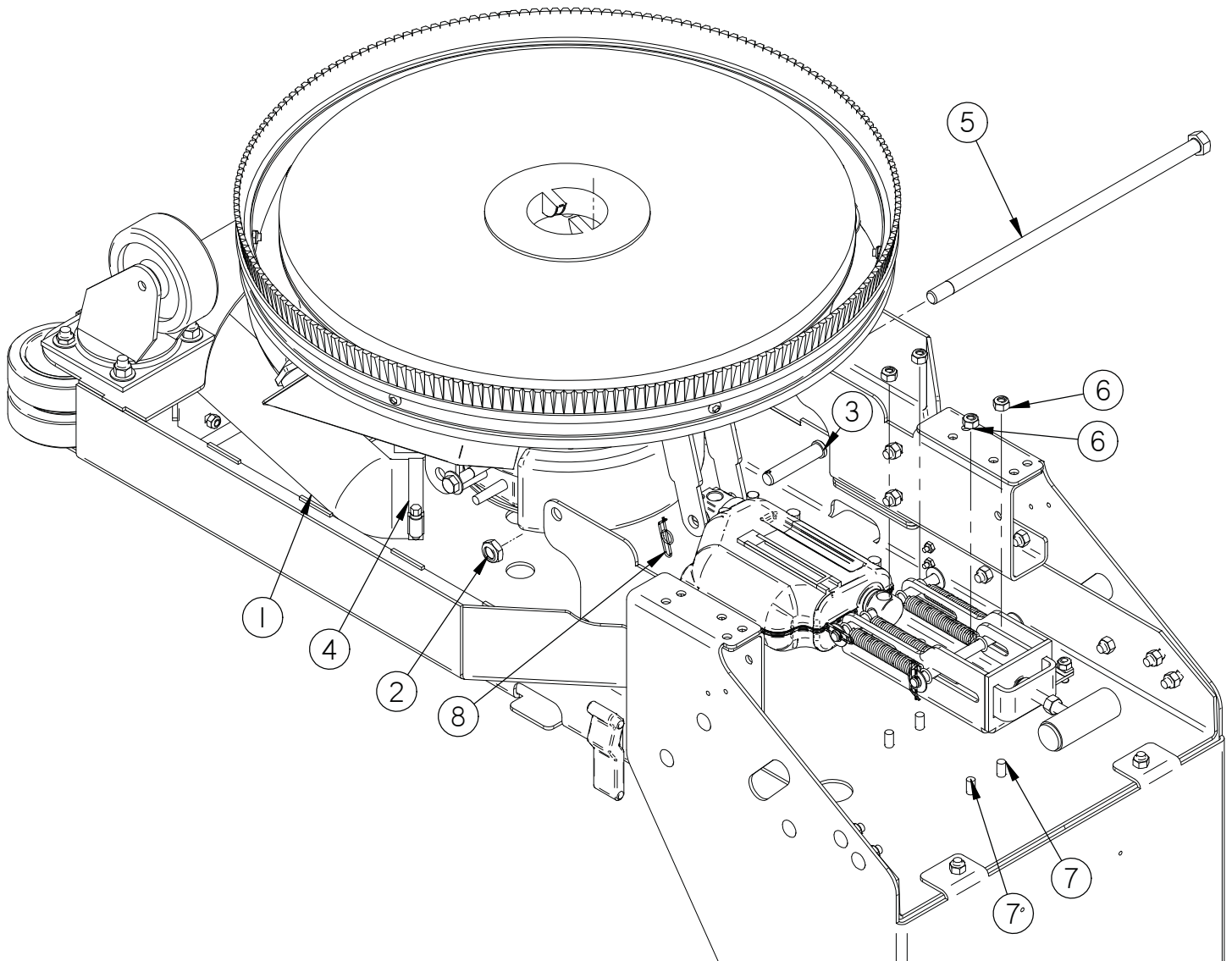

Item	Part No.	Part Description	Qty.
1	200-0115	MOTOR VENT HOSE	1
2	H-0129159	JNYL, 1/2"-13, 18-8 SS	1
3	H-0156773	CLEVIS PIN, 1/2" X 2-1/2"	1
4	H-0427617	CLAMP 2" - 3"	4
5	H-15237	HCS 1/2"- 13 X 13" GRADE 8	1
6	H-70861	NYLOK 5/16" - 18 SS	4
7	H-73907	FHSCS 5/16"- 18 X 3/4" SS	4
8	H-RUE22	1/2" RUE RING COTTER	1

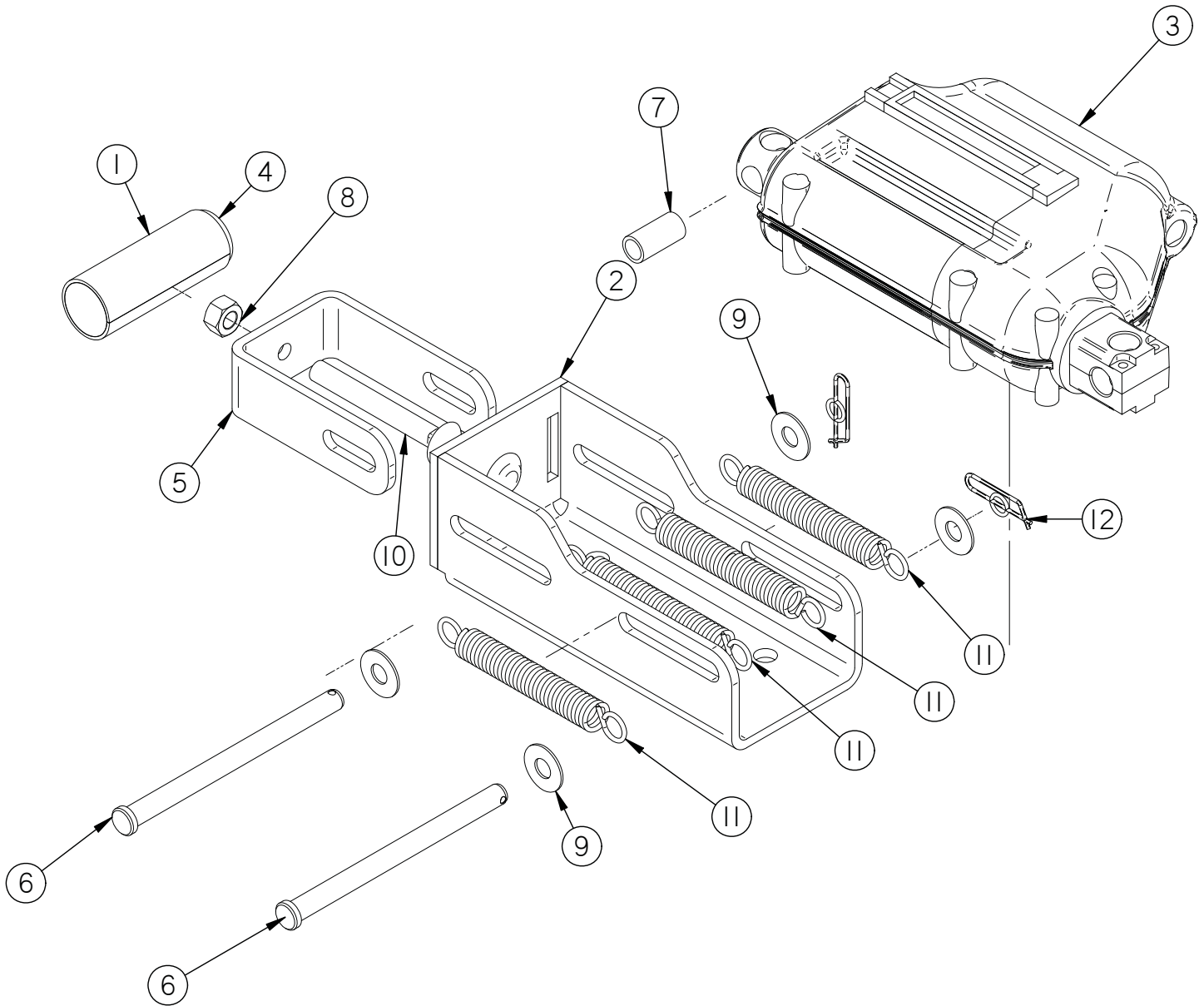

Item	Part No.	Part Description	Qty
1	200-0999	DOWN PRESSURE STICKER	1
2	200-1081	ACTUATOR SLIDE	1
3	200-2240	2 INCH STROKE 36 VOLT ACTUATOR	1
4	275-0999	HANDLE	1
5	275-1083	ACTUATOR SPRING AJUSTMENT BRACKET	1
6	H-04804	3/8" X 5" CLEVIS PIN	2
7	H-63917	SLEEVE, .50 OD X .375 ID X 1.0 LG	1
8	H-70712	HN 3/8"-16 SS	1
9	H-71017	FW 3/8" X 7/8" SS	4
10	H-74441	CB 3/8"- 16 X 3.0" SS	1
11	H-96544	SPRING, 4-1/8" LG, 9/16" OD	4
12	H-RUE14	3/8" RUE RING COTTER	2

FOR MACHINES WITH HD MOTOR
USE PART NUMBER 275-9506
78 AMPS 2500 RPM 3 HP

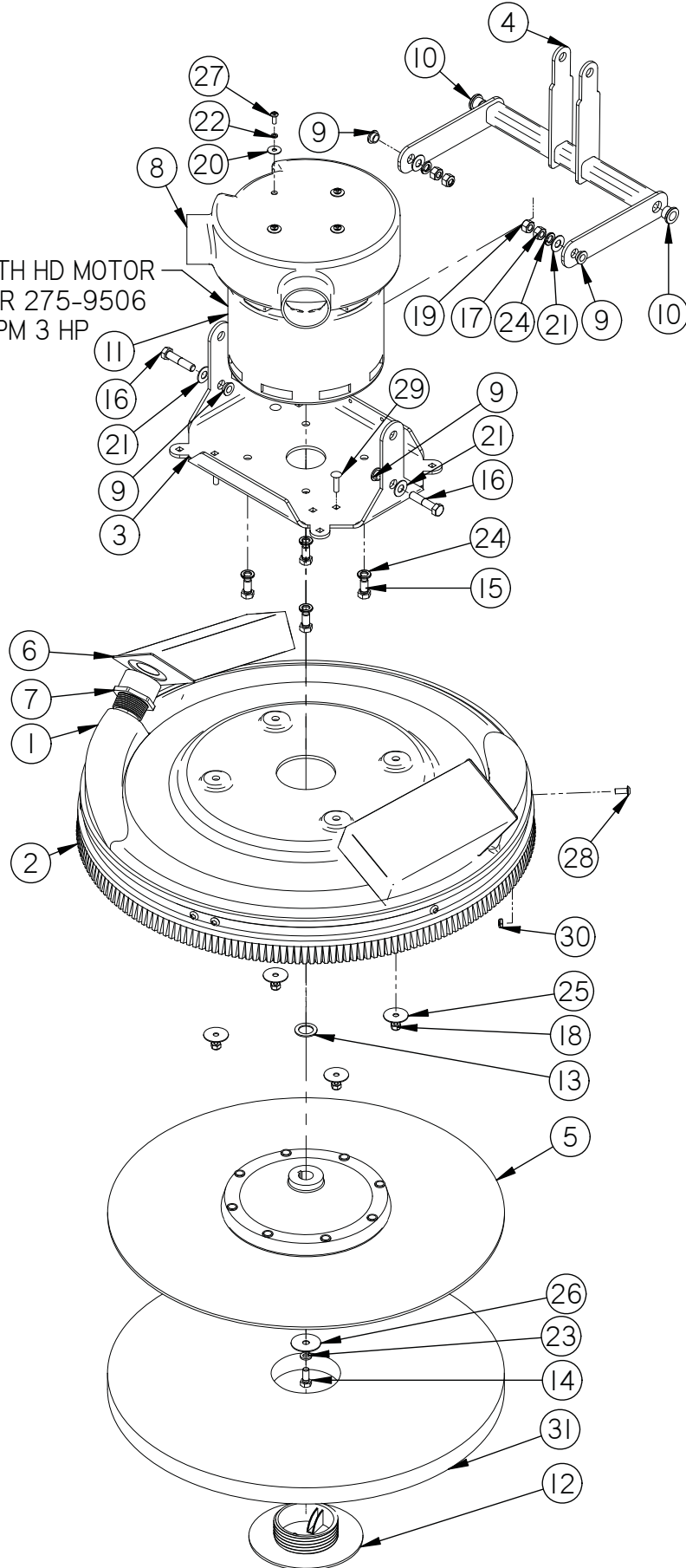

Item	Part No.	Part Description	Qty
1	200-0001	20" BURNISHER SHROUD	1
2	200-0016	20" SHROUD CURTAIN	1
3	200-1006	SCRUB DECK	1
4	200-1240	LIFT ARM	1
5	200-9569	20" DRIVER PLATE	1
6	253-1103	FILTER BAG	2
7	275-1201	1-1/4 NPT TO 2" OD ADAPTER	2
8	275-9501	MOTOR COVER	1
9	290-1233	3/8" ID, 1/2" OD, 1/4" LG BEARING	4
10	290-1246	1/2" ID X 5/8" OD X 1/2" LG FLANGED BEARING	2
11	290-9501	BURNISHER MOTOR 36V 2000 RPM 65 AMP	1
12	40-434	SCREW IN PAD LOCK	1
13	H-00222	FW 3/4" ID X 1 1/8" OD X 3/32" SS	1
14	H-70091	HCS 5/16"- 24 X 3/4" SS	1
15	H-70102	HCS 3/8"-16 X 5/8" SS	4
16	H-70110	HCS 3/8"- 16 X 1-3/4" SS	2
17	H-70712	HN 3/8"-16 SS	2
18	H-70860	NYLOK 1/4"- 20 SS	4
19	H-70862	NYLOK 3/8"-16 SS	2
20	H-71010	FW #10 ID X 11/16 OD SS	4
21	H-71017	FW 3/8 ID X 7/8 OD SS	4
22	H-71059	LW #10, SS	4
23	H-71065	LW 5/16" SS	1
24	H-71067	LW 3/8" SS	6
25	H-71213	FNW 1/4" X 1-1/4" SS	4
26	H-71215	FNW 5/16 ID X 1-1/2 OD SS	1
27	H-72515	PPH #10-32 X 1/2" S/S	4
28	H-73753	BHSCS 1/4 - 20 X 5/8" SS	7
29	H-74420	CB 1/4"- 20 X 1.0" SS	4
30	H-NJ04C	JNYL 1/4" - 20 SS	7
31	SEE COMMON WEAR PARTS	BURNISHER PAD	1

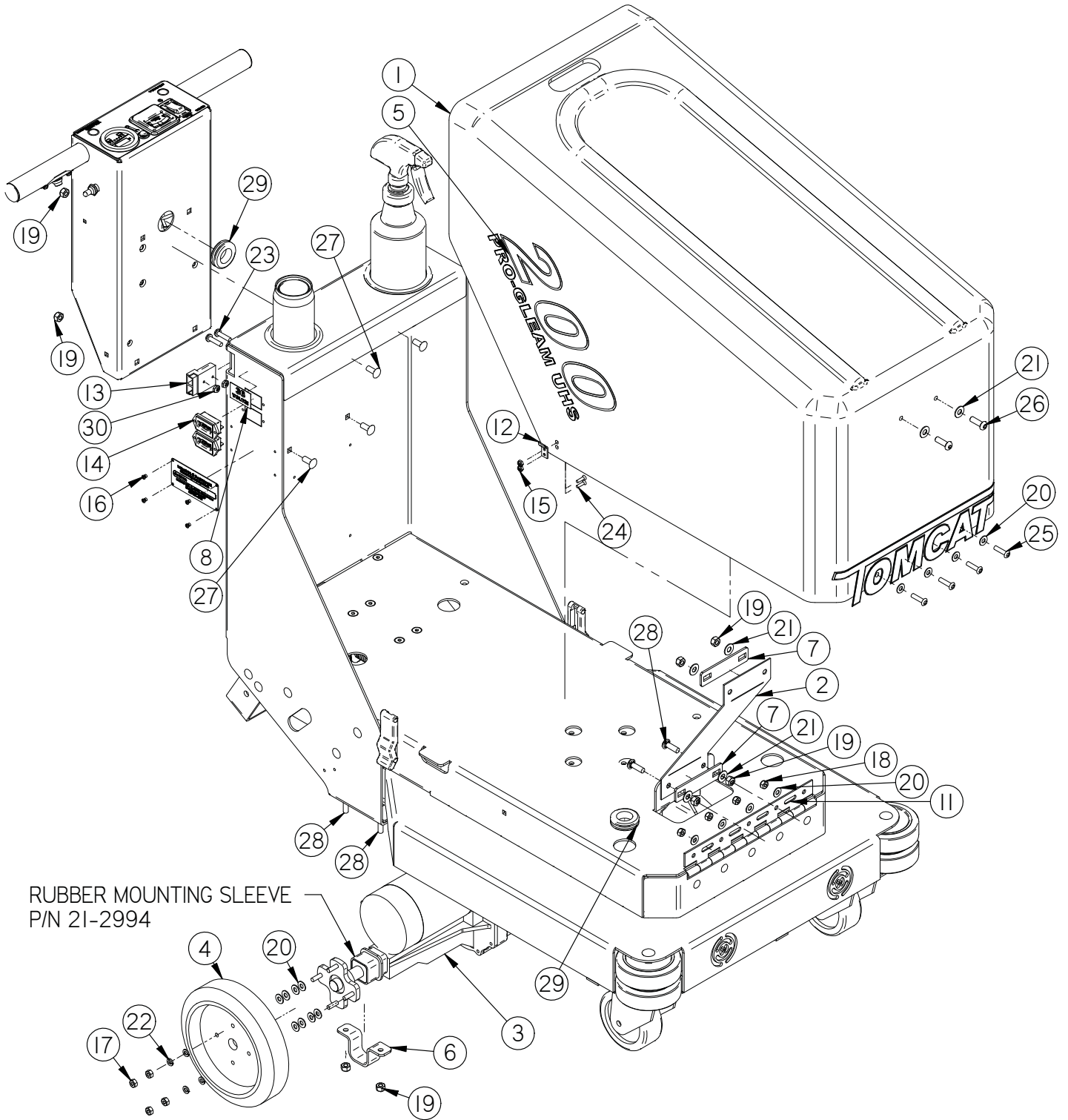

RUBBER MOUNTING SLEEVE
P/N 21-2994

Item	Part No.	Part Description	Qty.
1	200-1001	200/240 COVER	1
2	200-1050	TANK STRAP, 17-1/2" LG X 4" WIDE	1
3	200-3000	36V TRANSAXLE	1
4	200-3010	WHEEL	2
5	200-9504	200 DECAIL	2
6	21-1010	AXLE MOUNT	2
7	253-1040	TANK STRAP SUPPORT	2
8	290-1506	36 VOLT STICKER	1
9	370-0014	CUP HOLDER	1
10	370-0014	CUP HOLDER	1
11	390-1225	11" SS HINGE	1
12	4-124	CLIP, LATCH	2
13	4-260	CONNECTOR, GREY 50	1
14	8-262	HOUR METER	2
15	H-0170996	JAM NYLOK #8-32 SS	4
16	H-41007	AB4-3A BLIND RIVET	4
17	H-70710	HN 1/4"- 20 SS	4
18	H-70860	NYLOK 1/4"- 20 SS	4
19	H-70861	NYLOK 5/16" - 18 SS	13
20	H-71013	FW 1/4 ID X 5/8 OD SS	24
21	H-71015	FW 5/16 ID X 3/4 OD SS	6
22	H-71063	LW 1/4" SS	4
23	H-72592	PPH 1/4-20 X 1" SS	2
24	H-72643	FHP #8-32 X 5/8" SS	4
25	H-73755	BHSCS 1/4 - 20 X 1" SS	4
26	H-73780	BHSCS 5/16-18 X 1	2
27	H-74429	CB 5/16"- 18 X 3/4" SS	4
28	H-74430	CB 5/16"- 18 X 1" SS	6
29	H-9307K74	GROMMET, 1" ID X 1-3/4" OD BUNA-N	2
30	H-NJ04C	JNYL 1/4" - 20 SS	2

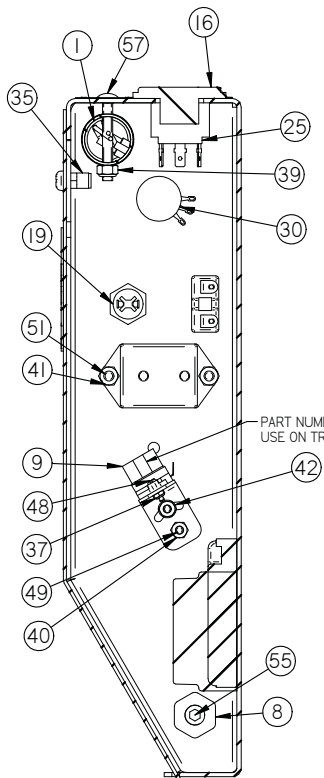
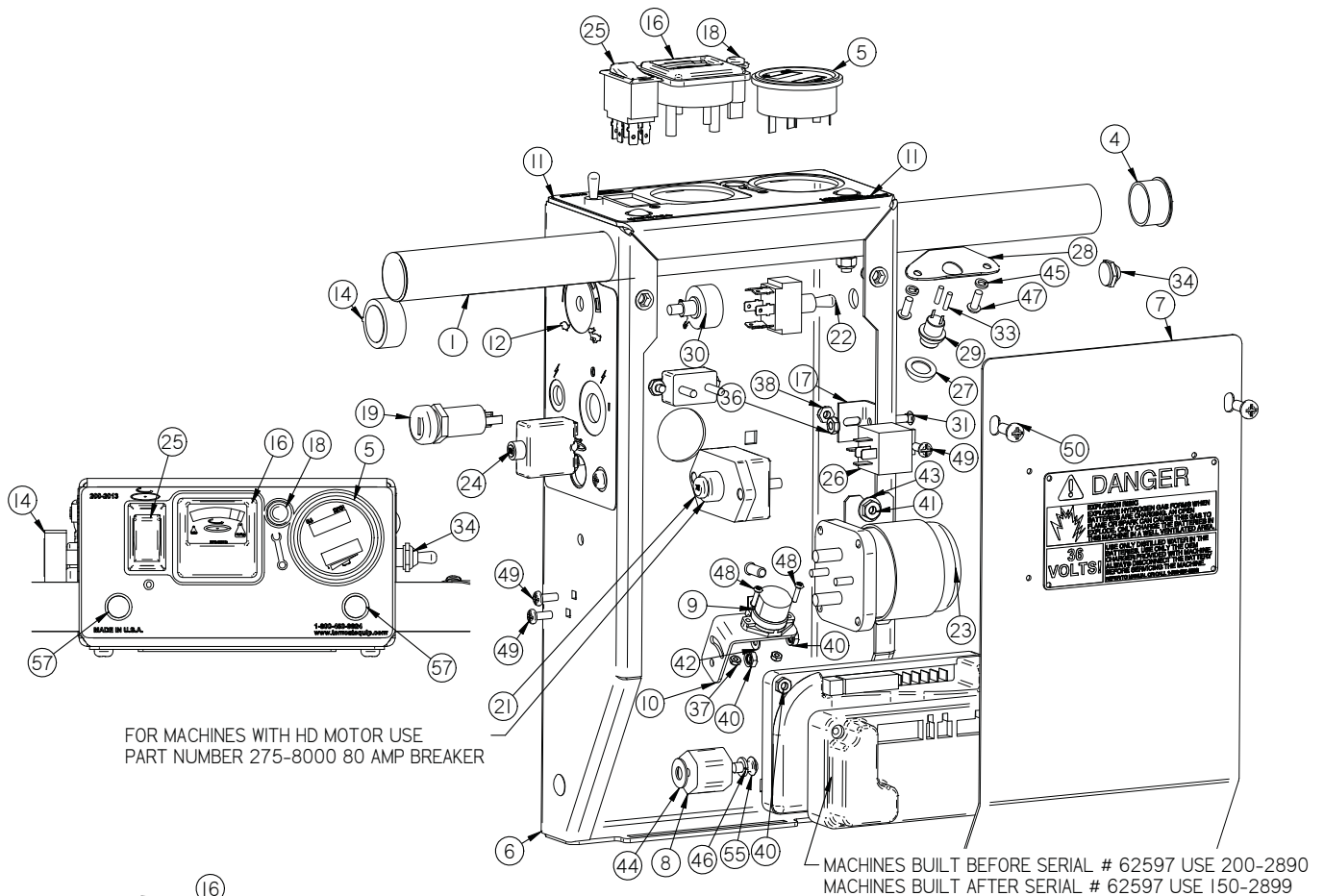

SECTION B-B

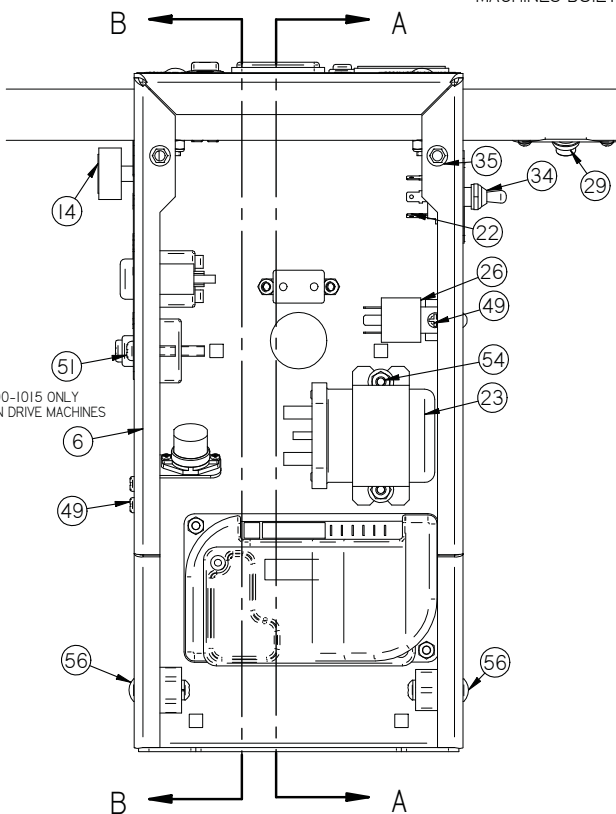

SECTION A-A

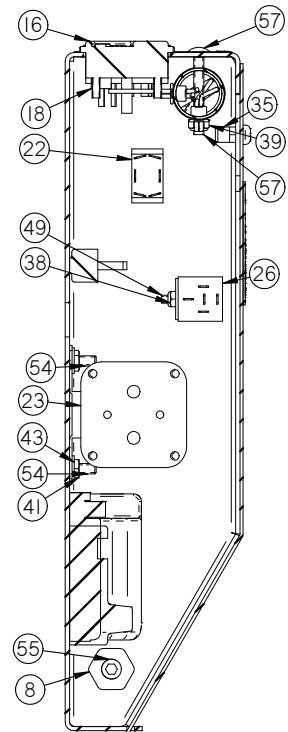

SECTION A-A

Item	Part No.	Part Description	Qty
1	170-1040	HANDLE BAR	1
2	190-1041	RED WIRE, 16 GAGE, 12" LG	1
3	190-1042	YELLOW WIRE, 16 GAGE, 12" LG	1
4	190-1390	END CAP	2
5	190-4855	24V BATTERY AND HOUR METER	1
6	200-1003	TRACTION DRIVE CONTROL PANEL	1
7	200-1007	CONTROL PANEL COVER	1
8	200-1011	SWITCHBOARD INSULATOR	2
9	200-1015	TILT SWITCH	1
10	200-1016	TILT SWITCH BRACKET	1
11	200-2013	200 CONTROL PANEL TOP STICKER	1
12	200-2014	200 CONTROL PANEL SIDE STICKER	1
13	200-2021	200/270 REVERSE STICKER	1
14	21-4520	SPEED CONTROL KNOB, RED	1
15	250-7290	36V BATTERY WARNING PLATE	1
16	275-0013	0 TO 100 AMP GAUGE 0-75 G 75-90 Y 90-100 R	1
17	290-2020	BRACKET	1
18	290-2310	FULL RECOVERY (RED)	1
19	290-234	KEY SWITCH (WITH KEY)	1
20	290-2815	CIR. BREAKER - 15A, 24V	1
21	290-7000	70 AMP BREAKER	1
22	370-2830	SWITCH, TOGGLE, MOM/OFF/MOM (DPDT)	1
23	390-2331	36V 200 AMP RELAY	1
24	390-9615	FUSE, RESETTABLE, 15 AMP, 50V DC MAX	1
25	5-234	SWITCH, ROCKER, DPDT, ON/ON	1
26	5-293	15 AMP RELAY	1
27	7-227	BUTTON COVER	1
28	7-228	SWITCH MOUNT PLATE	1
29	7-229D	PUSH BUTTON SWITCH	1
30	7-292	5K POTENTIOMETER	1
31	H-0172518	CB #10-32 X 1/2" SS	1
32	H-03124	1/4" ID, 3/8" OD, 3/8" LG FLANGED BEARING, NYLON	1
33	H-108	HEAT SHRINK	2
34	H-11196	PROTECTIVE BOOT, TOGGLE SWITCH, (RED)	1
35	H-250HCN	HCN 1/4"-20	2
36	H-37408	KN #10-32	1
37	H-70854	NYLOK #4-40 SS	2
38	H-70858	NYLOK #10-32 SS	3
39	H-70860	NYLOK 1/4"- 20 SS	2
40	H-70923	KN #10-32 SS	4
41	H-70925	KN 1/4-20 S/S	4
42	H-71009	FW #10 SS	1
43	H-71013	FW 1/4 ID X 5/8 OD SS	2
44	H-71015	FW 5/16 ID X 3/4 OD SS	2
45	H-71057	LW #8, SS	2
46	H-71063	LW 1/4" SS	2
47	H-72398	PPHMS #8-32 X 1/2" SS	2
48	H-72486	PPH #4-40 X 1/2" S/S	2
49	H-72515	PPH #10-32 X 1/2" S/S	3
50	H-72588	PPH 1/4-20 X 5/8" SS	2
51	H-72592	PPH 1/4-20 X 1" SS	2
52	H-72682	FHP #10-32 X 1/2" SS	2
53	H-72684	FHP 10-32 X 3/4" SS	2
54	H-72708	FHP 1/4"- 20 X 3/4"	2
55	H-73752	BHSCS 1/4 - 20 X 1/2" SS	2
56	H-74417	CB 1/4"- 20 X .5" SS	2
57	H-74423	CB 1/4"- 20 X 2.0" SS	2

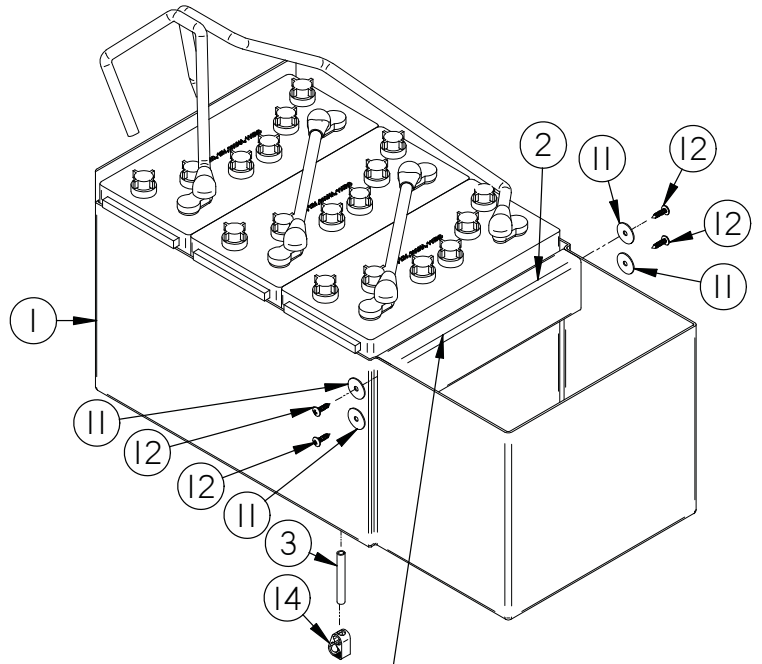
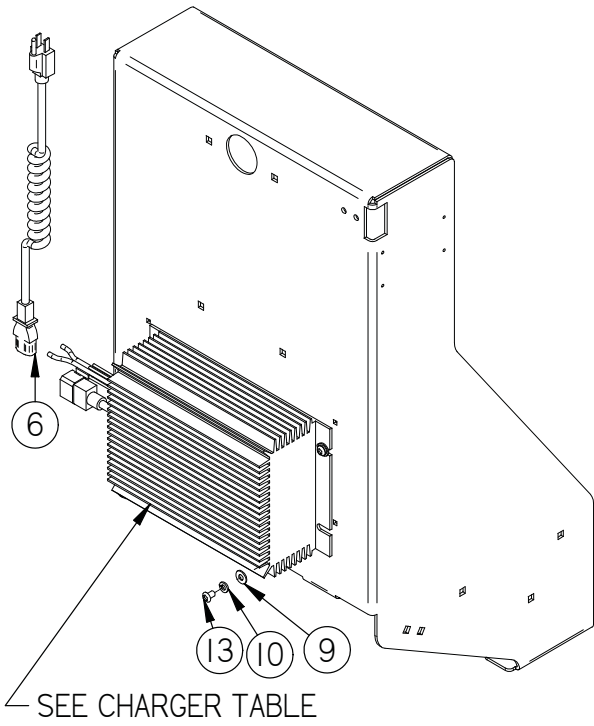

ONLY USED WITH 12V BATTERIES OPTION

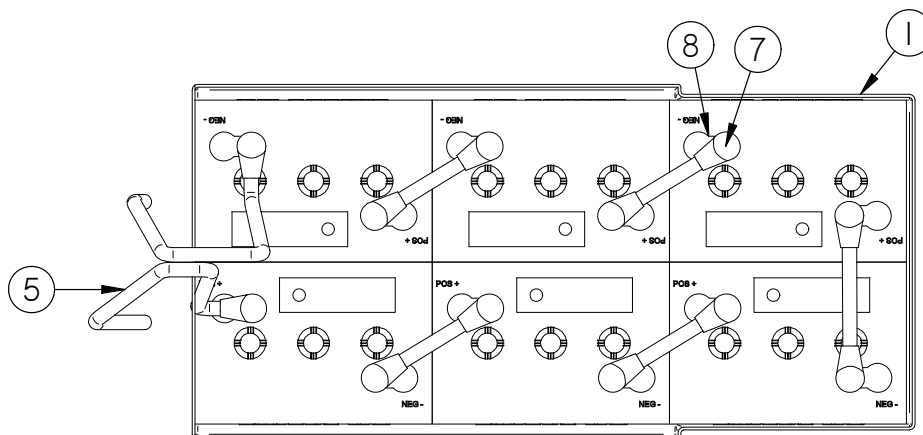
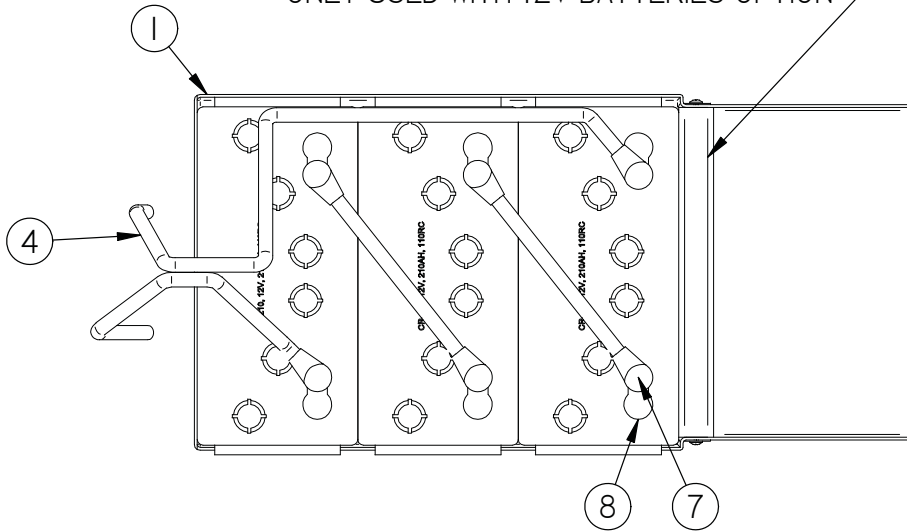

Item	Part No.	Part Description	Qty.
1	200-0000	BATTERY BOX	1
2	200-1495	BATTERY SPACER, 14.875"	1
3	200-1608	BLACK HOSE, 3-1/4" LG	1
4	200-1900	12 VOLT BATTERY CABLE KIT	1
5	200-1901	6 VOLT BATTERY CABLE KIT	1
6	253-3444	EXTENDED COIL, 16A WG, 3 CONDUCTOR	1
7	H-40031	BATTERY BOOT	18
8	H-400317	TERMINAL COVER	18
9	H-71013	FW 1/4" X 5/8" SS	4
10	H-71063	LW 1/4" SS	4
11	H-71213	FNW 1/4" X 1 1/4" SS	4
12	H-71894	#14 X 1" SELF TAPPING SCREW	4
13	H-73751	BHSCS 1/4 - 20 X 3/8" SS	4
14	M-503IK12	CLAMP STYLE PINCH VALVE	1

Charger table					
Model	Battery	Off-Board (US)	Off-Board (Euro)	On-Board (US)	On-Board (Euro)
200	4-271 (185 Ah)	250-2440	250-2442	250-2445	250-2446
	250-2113 (240 Ah)	250-2440	250-2442	250-2445	250-2446
	250-2114 (M-Free)	250-2450	250-2451	250-2452	250-2453

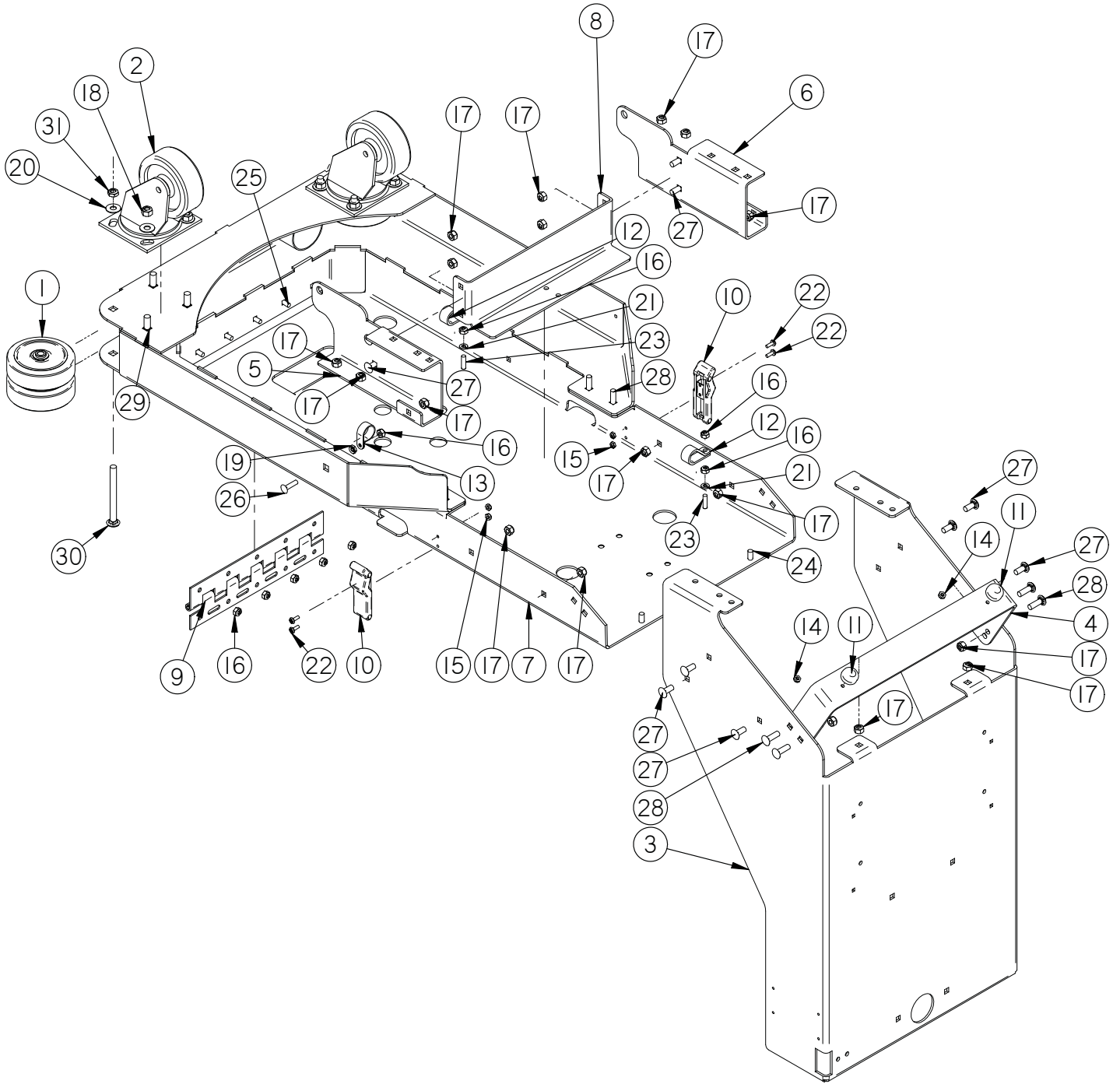

Item	Part No.	Part Description	Qty.
1	190-3030	4.0" WHEEL (GRAY)	4
2	190-3035	CASTER, NON-MARKING (RED)	2
3	200-1002	REAR UPRIGHT	1
4	200-1005	SUPPORT ARM	1
5	200-1009	REAR SUPPORT BRACKET - RH	1
6	200-1010	REAR SUPPORT BRACKET - LH	1
7	200-2000	200 MAIN FRAME	1
8	200-2001	FRAME STIFFENER	1
9	370-1225	11" SS HINGE	1
10	4-124	LATCH	2
11	H-01201	GROMMET	2
12	H-0127294	RUBBER LOOP CLAMP, 3/4"	2
13	H-0127296	LOOP CLAMP, 1.0"	1
14	H-0129154	JAM NYLOK #10-24 SS	2
15	H-70856	NYLOK #8-32 SS	4
16	H-70860	NYLOK 1/4"- 20 SS	9
17	H-70861	NYLOK 5/16" - 18 SS	20
18	H-70862	NYLOK 3/8"-16 SS	6
19	H-70925	KN 1/4-20 S/S	1
20	H-71017	FW 3/8" X 7/8" SS	8
21	H-71063	LW 1/4" SS	2
22	H-72398	PPH #8-32 X 1/2" S/S	4
23	H-73883	FHSCS 1/4- 20 X 1.0" S/S	2
24	H-73907	FHSCS 5/16"- 18 X 3/4" SS	2
25	H-74418	CB 1/4"- 20 X 5/8" S/S	5
26	H-74420	CB 1/4"- 20 X 1.0" SS	1
27	H-74429	CB 5/16"- 18 X 3/4" SS	10
28	H-74430	CB 5/16"- 18 X 1" SS	8
29	H-74436	CB 3/8"- 16 X 1.0" SS	6
30	H-74443	CB 3/8"- 16 X 4.0" SS	2
31	H-NJ06C	JNYL 3/8- 16 SS	2

Common wear parts

<u>Pad</u>	<u>Pad Function</u>	<u>Results</u>	<u>200 Part Number</u>
Image ultra high speed - beige	Ultra high speed High speed buffing And burnishing.	For high speed buffing and burnishing. For frequent burnishing on soft to medium finishes.	20-4221
Luster lite - blue	Ultra high speed buffing and burnishing.	For burnishing soft floor finishes. May be used on a daily basis. Ideally suited for top dressing highly polished floors.	20-4222
Combo ultra high speed	Ultra high speed buffing and burnishing.	Blended polyester and natural fibers. For frequent burnishing on medium finishes.	20-4223
Porko ultra high speed	Ultra high speed buffing and burnishing.	Blended natural fiber pad. For frequent minimal burnishing on hard finishes.	20-4224
Porko elite	Ultra high speed buffing and burnishing.	Blended natural fiber pad works on all UHS machines. For minimal burnishing on medium to hard finishes.	20-4225
Porko plus	Ultra high speed buffing and burnishing.	High content of natural fibers. Ideal for minimal burnishing on hard finishes.	20-4226

200 Suggested Parts Inventory

Quantity	Part #	Description
2	190-3035	Front Wheel Caster
4	190-3030	4.0"
2	H-73815	Side Wheel Bolt
2	4-124	Latch
2	255-1103	Vacuum Bags
2	200-3010	Rear Tires
2	200-9504	200 Stickers

BLANK
THIS PAGE WAS INTENTIONALLY LEFT BLANK

BLANK
THIS PAGE WAS INTENTIONALLY LEFT BLANK



1711 South Street
Racine, WI 53404
www.rpscorporation.com
Tel. US: 800-634-4060
Tel. Int: (001) 262-681-3583