



 EQUIPMENT

 PARTS

 RENTALS

 SERVICE

 SUPPLIES

USE & MAINTENANCE MANUAL

CONTACT US

 800.6.Bortek

 717.737.7591

 Orders@BortekIndustries.com

 BortekIndustries.com/CUSTOMERLINK



HAMMERHEAD[®]
900SX



This manual was expressly conceived to allow you to fully appreciate the technical advantages and the stylistic research of your new machine.

The following pages contain indications concerning its correct use and maintenance, as well as suggestions and warnings for its practical and safe use.

CHAPTERS INDEX

- CHAPTER** _____ **1** 2016-08
INTRODUCTION - WARNINGS
(Introduction - General warnings - Machine delivery - Expected use of the machine - Unexpected use of the machine - Use restrictions - Checks - Safety rules - Maintenance instructions - Fire standards - Scrapping the machine)
- CHAPTER** _____ **2** 2016-08
SAFETY DEVICES - HANDLING
(Warning plates - Safety devices - Residual risk areas - Handling and transport)
- CHAPTER** _____ **3** 2016-08
TECHNICAL DATA - IDENTIFICATION
(Technical data - Machine noise emission - Information about vibrations - Identification of the machine)
- CHAPTER** _____ **4** 2016-08
KNOWLEDGE - USE
(General views - Instruments and controls - Preliminary checks - Machine start - Cleaning work - Battery charging OPT)
- CHAPTER** _____ **5** 2016-08
MAINTENANCE
(Maintenance operations - Daily maintenance - Weekly maintenance - Periodical maintenance - Extraordinary maintenance)

CHAPTER 1

INTRODUCTION - WARNINGS

INDEX

1.1 - INTRODUCTION	3
1.1.a - Purpose of the manual	3
1.1.b - Reading the manual	3
1.1.c - Legend of the symbols	3
1.1.d - Terminology used in the manual.....	4
1.2 - GENERAL WARNINGS	5
1.2.a - Operators' instructions.....	5
1.2.b - Operator's position	5
1.2.c - Manufacturer's responsibility.....	5
1.2.d - Servicing	5
1.2.e - Spare parts.....	6
1.3 - MACHINE DELIVERY	6
1.4 - EXPECTED USE OF THE MACHINE	6
1.5 - UNEXPECTED USE OF THE MACHINE	6
1.5.a - Areas with explosion hazard.....	7
1.6 - USE RESTRICTIONS	7
1.7 - CHECKS	7

INDICE - INDEX

1.8 - SAFETY RULES	8
1.8.a - Authorized people	8
1.8.b - Accident prevention clothing and personal protective equipment .	8
1.8.c - General warnings	8
1.8.d - Before starting the machine	9
1.8.e - During use	9
1.8.f - Machine stop	10
1.8.g - Safety instructions for supplies	10
1.9 - MAINTENANCE INSTRUCTIONS	10
1.10 - FIRE STANDARDS	11
1.10.a - Machine fire	11
1.11 - SCRAPPING THE MACHINE	11

1.1 - INTRODUCTION

This manual has been prepared by the manufacturer and constitutes an integral part of the vehicle; it must therefore be kept with care and in a safe place easily accessible to all users (operators and service personnel) for the vehicle's entire life time up to its demolition.

If the vehicle should be sold, make sure to give this manual, as well as all the enclosed technical documents, to the new owner.

Copies of this manual and of the documents accompanying the vehicle may be requested to the manufacturer by specifying the type of vehicle and its serial number.

1.1.a - PURPOSE OF THE MANUAL

The purpose of this manual is to provide all the instructions necessary for the vehicle's operation, use and maintenance.

By carefully reading the instructions and by scrupulously observing the safety rules contained herein it is possible to obtain the best possible results in terms of performance, safety, efficiency, operational management and duration of the vehicle.

Non-observance of such instructions could cause damage or harm to the vehicle, to people and to the environment which cannot, in any case, be blamed on the manufacturer.

The indications and instructions of this manual are not meant to substitute, integrate or modify any REGULATION, DIRECTIVE, DECREE or LAW of a general or a specific nature in force in the country where the machine is to operate regarding safety, use and maintenance of mechanical, electric, chemical, oil-pressure, pneumatic or other types of devices.

1.1.b - READING THE MANUAL

The manual is subdivided in chapters according to a logical sequence of knowledge and use of the machine.

To easily search for the topics of interest, first look at the CHAPTER SUMMARY at the beginning of this manual and then look for the specific information in the summary of the identified chapter.

1.1.c - LEGEND OF THE SYMBOLS

To emphasize information and procedures regarding safety of use, maintenance, etc... the following symbols are used throughout the manual:



DANGER:

Indicates an imminently hazardous situation which, if not avoided, will result in death or serious injury.



WARNING:

Indicates a potentially hazardous situation which, if not avoided, could result in death or serious injury.



CAUTION:

Indicates a potentially hazardous situation which, if not avoided, may result in minor or moderate injury.

CAUTION:

Used without the safety alert symbol indicates potentially hazardous situation, which, if not avoided, may result in property damage.

NOTICE:

Indicates important information relevant to the sweeper, the sweeper's use or to sections of this manual to which particular attention must be paid.

REMEMBER:

Descriptions preceded by this symbol contain information, or procedures recommended by Dulevo for optimum use of the sweeper.

1.1.d - TERMINOLOGY USED IN THE MANUAL

The following terminology has been used in this manual:

*The term **Machine** is used instead of the commercial name to which this manual refers.*

*The terms **front, back, right, left, lower, upper** refer to the machine as seen by the operator sitting on the driver's seat.*

*The term **OPT (optional)** indicates the accessories that may be applied on request and which are therefore not always present on the machine.*

1.2 - GENERAL WARNINGS

1.2.a - OPERATORS' INSTRUCTIONS

Before operating, using or servicing the vehicle, its operators and/or users must be knowledgeable about the operating procedures, directions and safety standards listed in the present manual and in the other enclosed documents relative to engine, batteries, etc...

Furthermore, they must have been practically trained to operate the vehicle.

1.2.b - OPERATOR'S POSITION

When working, the operator leads the machine manually.

1.2.c - MANUFACTURER'S RESPONSIBILITY

The manufacturer declines any responsibility arising from breaks, accidents, etc... due to the lack of knowledge (or to the lack of application) of the warnings and instructions contained in this manual, or for any misuse, abuse or for any change, variation and/or installation of accessories that has not been previously authorized in writing by the manufacturer.

In particular, the manufacturer declines any responsibility for any damage caused by:

- **Acts of God**
- **Wrong maneuvers**
- **Lack of maintenance**

The manufacturer cannot be held responsible for damages of any type (including but not limited to property damage, damage to the machine, personal injury or death) caused by the operations performed on or modifications to the machine (servicing, repair, etc...) if they were not carried out by AUTHORIZED PERSONNEL by the manufacturer.

1.2.d - SERVICING

The manufacturer offers its customer its own Technical Assistance Service to solve any problem concerning machine use and maintenance. Any request for technical assistance must be made after a careful analysis of the problems and their causes.

In case of a written request, please specify the following:

- *Machine model*
- *Serial number*
- *Detail of the problems encountered*
- *Inspections that have been performed*
- *Adjustments made and their outcome*
- *Any other useful information*

1.2.e - SPARE PARTS

Exclusively use **ORIGINAL SPARE PARTS** supplied by the manufacturer.

The use of unoriginal spare parts voids the warranty conditions and makes the user responsible for any incident due to the inappropriateness of the unoriginal components.

1.3 - MACHINE DELIVERY

The machine is inspected and tested by the manufacturer before it leaves the factory.

The sales network must run further inspections before delivery.

When the machine is delivered, check that it is complete with all the requested accessories and the tool kit, and that it is accompanied by the following documents:

- Machine use and maintenance manual;
- Spare parts manual;
- Warranty;
- Other documents related to electrical motor, batteries, accessories, wiring diagram, etc...

1.4 - EXPECTED USE OF THE MACHINE

The machine may only be used for industrial cleaning operations and to collect dust, debris, paper, leaves, etc...



WARNING:

Any other use makes the user the only one responsible for damages to people and/or things and voids all warranty conditions.

1.5 - UNEXPECTED USE OF THE MACHINE



WARNING:

Sweeping and/or sucking any type of material set on fire, incandescent or having a temperature higher than 50°C (122°F) is forbidden.

Do not sweep and/or suck any type of inflammable, explosive, toxic, carcinogenic material/waste (solid, liquid, gaseous, powders) (gasoline, fuel oil, acids, solvents, thinners for varnishes, acetone, even if diluted) and/or other substances that are harmful for people's health.

1.5.a - AREAS WITH EXPLOSION HAZARD

It is strictly forbidden to use the machine in places where there is a risk of explosion due to gases, vapors, fluids, and inflammable and explosive powders.

1.6 - USE RESTRICTIONS

- *In order to be able to reach all the control devices with ease and avoid any ergonomically incorrect position, the operators' height must be neither inferior to 1,50 m (60 inch) and nor superior to 2,05 m (80 inch) (shoes included).*
- *When using the machine in environments with corrosive debris or extreme climates, heavy magnetic fields, saline air and brackish water, etc... please consult the sales network for additional use/maintenance requirements.*

NOTE:

The manufacturer shall not be held responsible for mechanical issues, failures, breaks or accidents, due to the use of the machine under conditions different than those specified in "chapter 3" or elsewhere in this manual.

1.7 - CHECKS

*Before beginning work, **CHECK** that all safety and emergency devices are in place, in good condition and working properly.*

Do not start the machine if any safety shield, guard, control, instrument, signal light or signal buzzer, or other protective device, is not in place and working properly.

The following checks must be carried out:

- *Before starting the machine;*
- *At regular time intervals (see chapter 5);*
- *After any modification or repair;*
- *Also see "Preliminary checks, chapter 4".*

Safety devices check

The machine's safety devices must be checked by properly trained technicians once every six months.

The technician must prepare a check report at the end of the inspection.

General overhaul

Every 5000 hours of running or at least once every 5 years, the machine must be overhauled by a workshop authorized by the manufacturer.

1.8 - SAFETY RULES



WARNING:

Please comply with the following instructions:

1.8.a - AUTHORIZED PEOPLE

- *Only professional and physically fit operators are allowed to use this machine. People with reduced physical, sensorial or mental capacities like physically handicapped people suffering impairment of sight, hearing or limbs are not allowed to use this machine.*
- *Only the operators having been trained during an appropriate period of time, both theoretically and practically, on how to use the vehicle are allowed to use, maintain and repair the vehicle. The operators will be authorized to operate the vehicle (users) or maintain it (maintenance men) only after having been properly trained.*
- *These operators must be physically and intellectually fit. Furthermore, they must not be under the effects of alcohol, medicaments and/or drugs.*
- *Do not allow unauthorized people to get close to the machine.*

1.8.b - ACCIDENT PREVENTION CLOTHING AND PERSONAL PROTECTIVE EQUIPMENT

- *Do not wear fluttering clothing and/or objects which might get caught (rings, bracelets, necklaces, etc...), but always do wear accident prevention clothing according to the regulations in force.*
- *People with long hair must gather their hair before starting to use the machine.*
- *Always wear safety work shoes with anti-slip soles. If the environmental and operation conditions require it, also wear gloves, masks, glasses and hearing protection devices.*
- *Wear additional PPE as needed or when required by your employer, local codes, or the nature of the work.*

1.8.c - GENERAL WARNINGS

- *Never modify any component of the machine, or the settings or calibrations set by the manufacturer.*
- *Do not cause short circuits.*
- *Do not invert polarity of battery pole connections.*
- *Do not rest tools or metal objects on the batteries; danger of short-circuits.*

- *Use a battery charger appropriate to the battery's capacity and features.*
- *Do not move the machine manually and do not start it while the battery is charging.*
- *Never remove or modify fixed or mobile shielding guards.
If, for any reason, the shields or guards are removed, modified or if the guards are disabled or in poor condition, they must be restored to their original condition before restarting the machine.*
- *Always maintain the safety decals in good, readable condition.

If the decals are missing, damaged, or unreadable, obtain and install replacement decals immediately.*

1.8.d - BEFORE STARTING THE MACHINE

- *Walk around the machine to insure that all components are in good condition and operational.*
- *Make sure that no foreign object is on the machine (rags, tools, etc...).*
- *Make sure all the battery caps are positioned correctly in their seat.*
- *The machine may only be operated after its good condition has been verified.*

1.8.e - DURING USE

- *Operate the machine controls from the driver seat only.*
- *In the event you hear any strange noise or feel unusual vibration, if component or system is not operating properly, stop the machine immediately.
Look for the cause and, if necessary, inform the Assistance Service.*
- *Operate very carefully and make sure nobody may touch the brushes while they are rotating.*
- *Never try to brush objects that are either too voluminous or that could get entangled in the machine brushes (such as cables, ropes, chains, etc...) and then be thrown away.*
- *In case of use of the machine on an inclined surface, follow the maximum slope line in order to avoid a rollover of the machine or situations that could compromise it's stability.*
- *Communicate any battery fluid leaks: they are dangerous and highly polluting.*

1.8.f - MACHINE STOP

- *The machine must be protected against accidental movements when it is not in operation.*
- *To prevent the machine being used by unauthorized persons, remove the starting key.*
- *Do not start the machine if it is stopped for special servicing (tune up, maintenance, etc...).*
- *Never leave the machine on sloping surfaces.*

1.8.g - SAFETY INSTRUCTIONS FOR SUPPLIES

Battery acid

- *Do not inhale the vapor: it is toxic.*
- *Use appropriate individual protection devices to avoid contact with the skin.*
- *Battery acid is corrosive: rinse with plenty of water in case of contact with battery acid.*
- *Explosive gas mixtures may form while charging the battery, it is therefore necessary that the premises where the battery is charged comply with the specific regulations.*
- *Do not smoke or use open flames within a 2-meter radius of the battery while it is being charged in the battery-charging area or while it is cooling after having been charged.*

1.9 - MAINTENANCE INSTRUCTIONS



WARNING:

A general mechanical knowledge is not enough to service and repair the machine; a specific mechanical knowledge is necessary.

Therefore, only properly trained technicians are allowed to execute any service and repair operation.

- *When carrying out cleaning or maintenance operations on the machine, or when replacing machine parts, turn off the engine, remove the starting key and disconnect the battery.*
- *Wear individual protective equipment and clothes, in compliance with the laws in force.*
- *Use only original spare parts.*
- *Follow the instructions outlined in “chapter 5”.*

CAUTION:

To clean and wash the machine, do not use aggressive or acid cleansers and pay special attention to the electric parts and to the engine.

Comply with the instructions provided by the cleanser’s manufacturer.

For cleaning operations, comply with the instructions outlined in “chapter 5”.

1.10 - FIRE STANDARDS



WARNING:

An appropriate fire extinguisher must be available close to the machine.

1.10.a - MACHINE FIRE

- Stop the engine.
- Keep strangers away.
- Call the personnel in charge of fire prevention and, if necessary, the Fire Department.

1.11 - SCRAPPING THE MACHINE

The machine is composed of different parts. Dismantle it and prepare the wastes for disposal in accordance to their type.



WARNING:

Machine disassembly must be carried out by specialized technicians (mechanics, electricians, etc...).

For the disposal of noxious substances (such as batteries, etc...), please comply with all applicable rules and regulations.

NOTICE:

Any irregularity committed by the customer before, during or after scrapping and disposal of the machine components, or in the interpretation and application of current regulations, is his own exclusive responsibility.

Adequate waste disposal of equipment no longer being used and the consequent recycling, treatment and environment compatible disposal avoids possible negative effects on the environment and on health, and favors reutilization and/or recycling of the materials making up the equipment.

Abusive product disposal by the user results in the financial penalties contemplated by current regulations.

900SX

CHAPTER 2

SAFETY DEVICES - HANDLING

INDEX

2.1 - WARNING PLATES	2
2.2 - SAFETY DEVICES	4
2.3 - RESIDUAL RISK AREAS	5
2.4 - HANDLING AND TRANSPORT	5
2.4.a - Lifting and transport	5
2.4.b - Assembling the handlebar	6
2.4.c - Assembling the side brushes	6

2.1 - WARNING PLATES

1) **General notices**

Plate placed near the dashboard; it forbids the use of the machine by persons not authorized to do so or not adequately trained in its proper operation or in the safety devices and regulations.

The manufacturer declines any responsibility deriving from wrong operations and from non-compliance with general work place safety rules.

2) **Warning: It is forbidden to smoke or use open flames**

Plate placed near the battery; it indicates that it is strictly forbidden to smoke or to use open flames near the tank or battery, so as to avoid any explosion or fire hazard.

3) **Warning: Keep the cover open while charging the battery**

Plate placed near the battery; it indicates that the inspection cover must always be open while charging the battery.

4) **Danger: Risk of hands being dragged by moving parts**

Plate placed near the dust suction turbine and driving belts; it indicates that the moving parts are dangerous.

5) **Warning: avoid contact with water**

Plate placed in the engine compartment; it indicates to pay attention that the motor and the electrical components are not in contact with water.

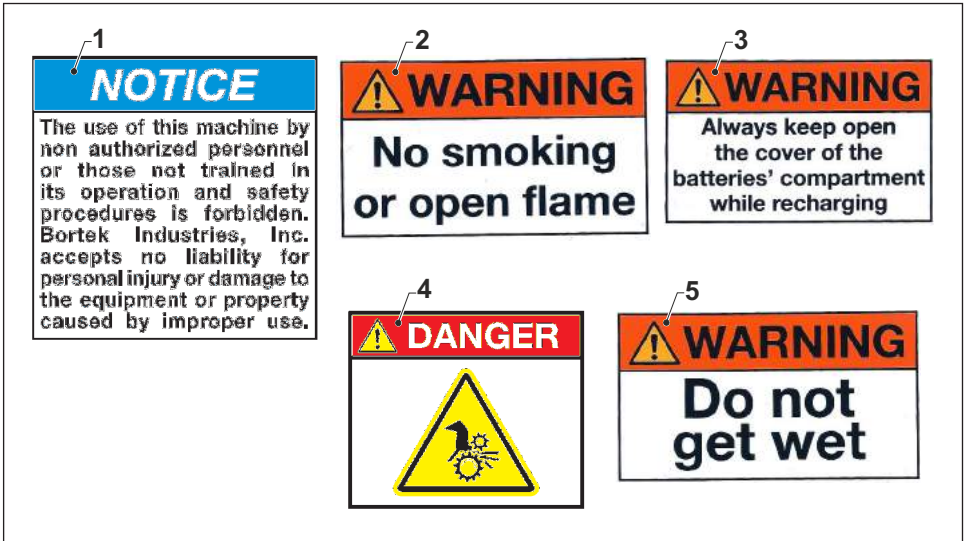

2.2 - SAFETY DEVICES

- Starting key (1).
- Microswitch (2); it stops the machine if the main cover (3) is lifted when the machine is operative.

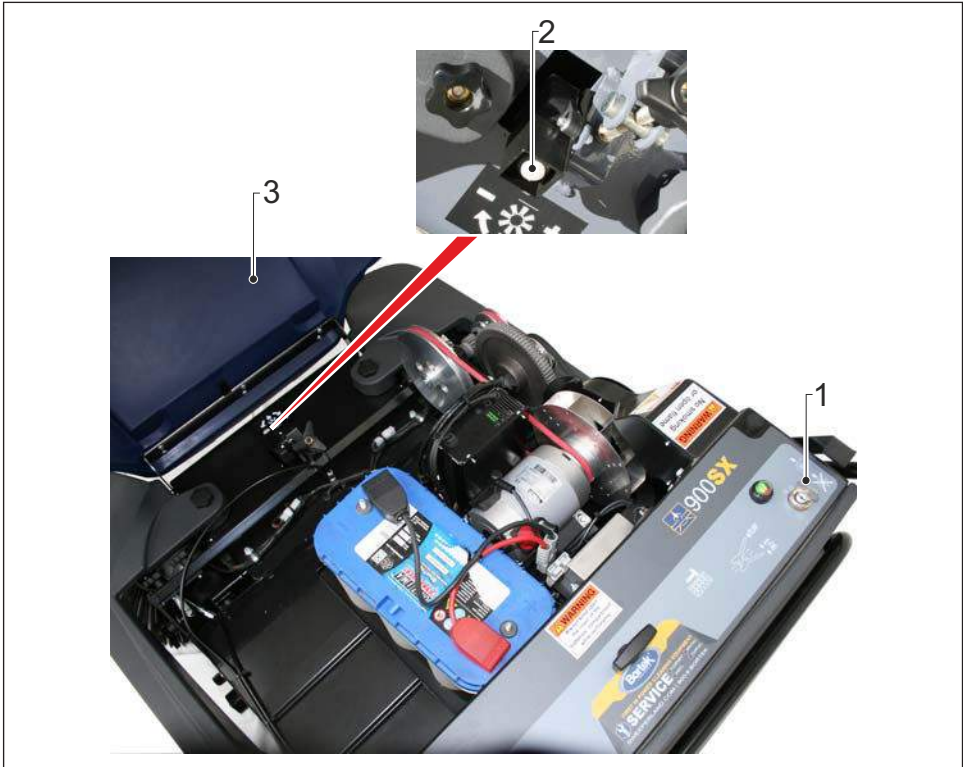

2.3 - RESIDUAL RISK AREAS

The residual risk areas are those parts (or areas) of the machine where, although safety devices are present, there remains a potential danger that is impossible to remove. Whenever the machine is moving, all the areas surrounding it are to be considered residual risk zones.

Therefore, pay maximum attention.

2.4 - HANDLING AND TRANSPORT



WARNING:

Dangerous manoeuvres.

*All loading and unloading operations must be carried out by **SPECIALIZED PERSONNEL**.*

For the machine mass see “chapter 3”.

See “chapter 4” for the description of the controls and the use of the machine.

CAUTION:

Remove the packing material very carefully in order not to damage the machine.

2.4.a - LIFTING AND TRANSPORT



WARNING:

It is strictly forbidden to lift the machine as it is not equipped with the anchoring points necessary for this operation.

Whenever the machine must be transported, fasten it onto the pallet or truck platform; apply wedges to the wheels and tie it up with belts and/or cables.

2.4.b - ASSEMBLING THE HANDLEBAR

- Lift the main cover (1).
- Release the 8 screws (2).
- Adjust the handlebar (3) at the desired height for work, then tighten the screws (2).



2.4.c - ASSEMBLING THE SIDE BRUSHES

- Assemble the side brushes as indicated in “chapter 5”.

CHAPTER 3

TECHNICAL DATA - IDENTIFICATION

INDEX

3.1 - TECHNICAL DATA	2
3.1.a - Limit weather conditions for the use	2
3.2 - MACHINE NOISE EMISSION.....	3
3.3 - INFORMATION ABOUT VIBRATIONS.....	3
3.4 - IDENTIFICATION OF THE MACHINE.....	4
3.4.a - Identification plate.....	4
3.4.b - Sound power plate.....	4

3.1 - TECHNICAL DATA

Dimensions:	
Length	1320 mm
Width	1072 mm
Height	920 mm
Weight (*)	135 kg
Electric motor:	
Supply	Battery 12 V
Cooling	Air
Total installed power	560 W
Cleaning track:	
Main brush only	700 mm
With right side brush	900 mm
With right and left (OPT) side brushes	1100 mm
Ø of main and side brushes	260 - 330 mm
Performance:	
Waste box capacity	50 liters
Filtering surface	2,1 m ²
Efficiency per hour	4900 m ² /h
Max. speed	4,5 km/h
Max. operating gradient	2 %
(*) With standard battery installed, hopper bin empty, without options.	
1 mm = 0.03937 inch	

3.1.a - LIMIT WEATHER CONDITIONS FOR THE USE

- Maximum ambient temperature:
+40°C (104°F)
- Minimum ambient temperature:
-5°C (23°F)
- Relative humidity:
between 30% and 95% (without condensates)

3.2 - MACHINE NOISE EMISSION

The test conditions under which the phonometric survey and the calculation of the sonic power were carried out comply with applicable regulations and directives and are described in detail in the various technical reports kept by the manufacturer.

In case of accidental and/or instrumental errors, the uncertainty relative to the values indicated below is $K= 2$ dB.

L_{pA} : A - WEIGHED AVERAGE EMISSION SOUND PRESSURE LEVEL

This is an indicator of what is perceived by the human ear and consequently constitutes the value used to assess the operators' exposure to noise.

$$L_{pA} = 66 \text{ dB (A)}$$

L_{wA} : WEIGHED SOUND POWER LEVEL A ISSUED BY THE MACHINE IN THE ENVIRONMENT

$$L_{wA} = 83 \text{ dB (A)}$$

(See paragraph "SOUND POWER PLATE POSITIONING").

3.3 - INFORMATION ABOUT VIBRATIONS

The vibrations have been measured in a typical condition of machine use, i.e. during work and with operating working tools.

The tests have been done on a plane surface, with roadbed in good conditions.

The vibrations have been measured and rated according to the requests of the applicable directive; they are described in detail in the relative technical report kept by the manufacturer.

The equivalent vibration levels produced by the machine in working conditions is:

- *for the hand-arm system: lower than $2,5\text{m/s}^2$.*

These values relate to the time of actual use of the machine.





They may be used only as comparison values and are not suitable to determine the operator's real exposure levels, which depend on the conditions and environment of use.

3.4 - IDENTIFICATION OF THE MACHINE

NOTICE:

The machine plates are the only legal identification reference, hence it is necessary to keep them in good condition, to avoid modifying the data and/or removing them. The Customer is responsible for any possible tampering with.

3.4.a - IDENTIFICATION PLATE

 SWEEPERLAND.COM			
Production Year 2016	Power Source 12 V	 Battery Weight 57 lbs.	
Max. Op. Gradient 2% 	Power Consumption 560 W	 Machine Weight 405 lbs.	IP23
Model Name: 900SX 		Item Number: 0210174EH S/N 74EH000XXX	

3.4.b - SOUND POWER PLATE

(See paragraph 3.2)

It indicates the guaranteed sound power level.

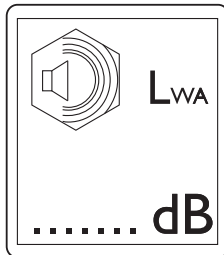

CHAPTER 4

KNOWLEDGE - USE

INDEX

4.1 - GENERAL VIEWS	2
4.1.a - Front and rear view	2
4.1.b - Internal view	3
4.2 - INSTRUMENTS AND CONTROLS	4
4.3 - PRELIMINARY CHECKS	6
4.3.a - Battery charge level	6
4.4 - MACHINE START	7
4.5 - CLEANING WORK	8
4.5.a - Starting the sweeping	8
4.5.b - Stopping both the sweeping and machine	8
4.5.c - Emptying the waste box	9
4.6 - BATTERY CHARGING (OPT)	10

4.1 - GENERAL VIEWS

4.1.a - FRONT AND REAR VIEW



- 1) Main cover
- 2) Waste box
- 3) Dust filter access cover
- 4) Handlebar
- 5) Dashboard
- 6) Control levers

- 7) Main brush
- 8) Left side brush (OPT)
- 9) Right side brush
- 10) Flap
- 11) Caster with locking device
- 12) Rear wheels

4.1.b - INTERNAL VIEW

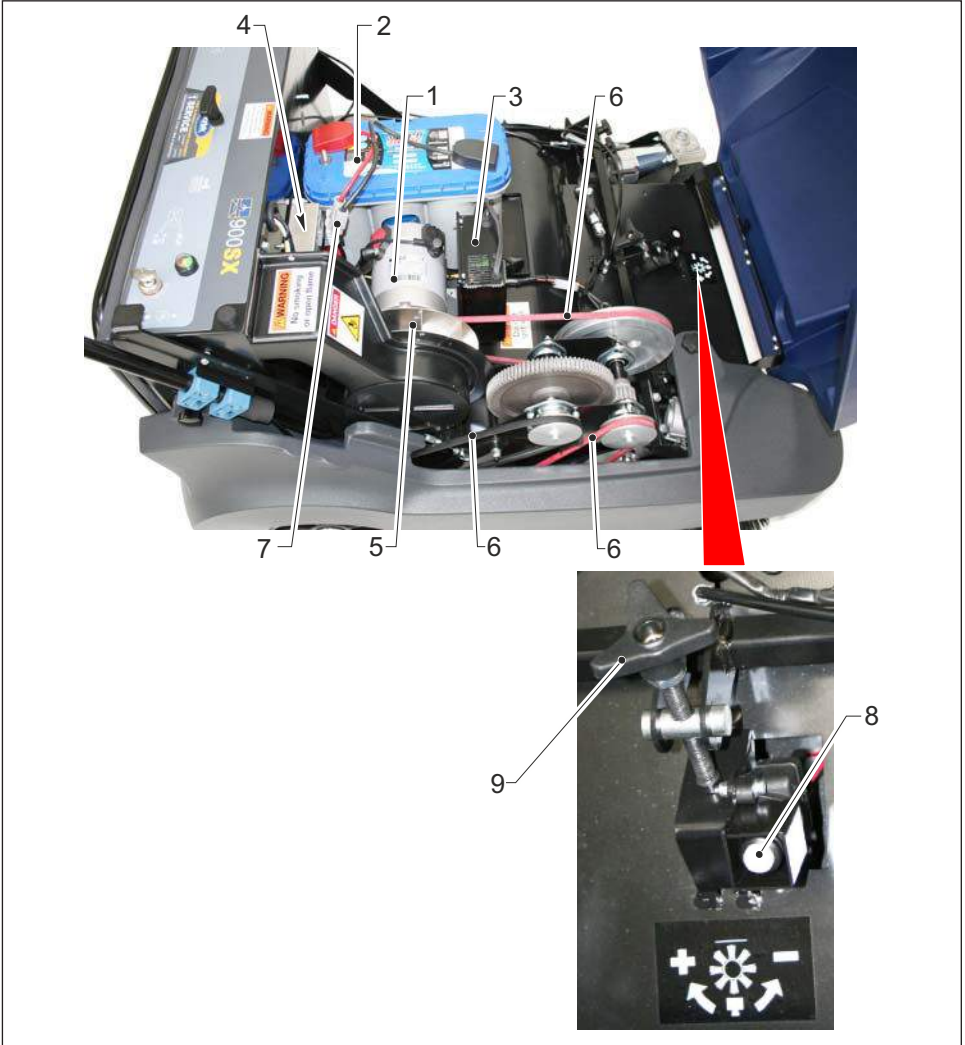

- 1) Electric motor
- 2) Battery (OPT)
- 3) Battery charger (OPT)
- 4) Fuses
- 5) Dust suction turbine
- 6) Driving belts
- 7) Battery cables connector
- 8) Safety microswitch
- 9) Main brush ground pressure adjusting knob

4.2 - INSTRUMENTS AND CONTROLS

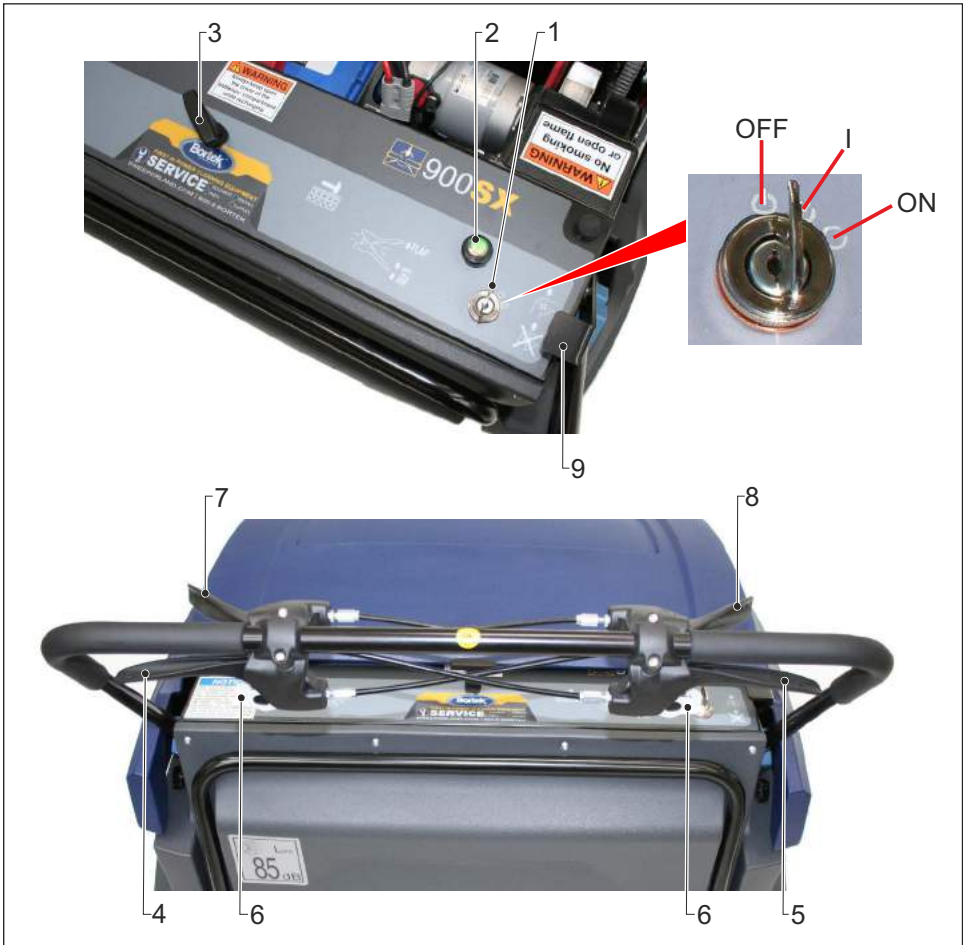

- 1) Starting key
- 2) Battery charge indicator
- 3) Filter shaker control
- 4) Left brush activation lever (OPT)
- 5) Right brush activation lever
- 6) Lever release
- 7) Forward running control lever
- 8) Flap opening lever
- 9) Dust suction control lever

1) Starting key

The starting key has 3 positions:

- **Position "OFF":**
Key extraction position (all circuits de-energized).
- **Position "I":**
All the circuits are energized.
- **Position "ON":**
Starting position.

2) Battery charge indicator

The light of this instrument's LEDs indicate to which degree the battery is charged.

Green LED= max. charge

Yellow LED= min. charge

Red LED= battery discharged

The battery must be recharged as soon as only the red LED is on.

3) Filter shaker control

Pull the control to operate the filter shaker and clean the dust filter.

NOTICE:

This operation must be executed approximately every 5 to 10 minutes, with dust suction turned off.

4) Left brush activation lever (OPT)

- Release the lever to start the rotation and lower the left brush.
- Press the lever to stop the rotation and lift the left brush.

5) Right brush activation lever

- Release the lever to start the rotation and lower the right brush.
- Press the lever to stop the rotation and lift the right brush.

6) Lever unlocking

- Press to release the levers (4) and (5).

7) Forward running control lever

Press this lever to move the machine forward.

8) Flap opening lever

Press this lever to open the flap to collect bulky waste.

9) Dust suction control lever

- Lift this lever to disable the dust suction.
- Lower this lever to enable the dust suction.

CAUTION:

In order not to damage the filter shaker, exclude the suction whenever working on a wet surface and/or when using the filter shaker.

4.3 - PRELIMINARY CHECKS

CAUTION:

Daily check the points listed below to keep your vehicle in good order. These checks are additional and do not replace programmed maintenance.



CAUTION:

In case of any malfunction or any doubt about the machine's functionality DO NOT use it and contact the technical assistance service.

4.3.a - BATTERY CHARGE LEVEL

Check battery charge level through the lighting of the LEDs (1).

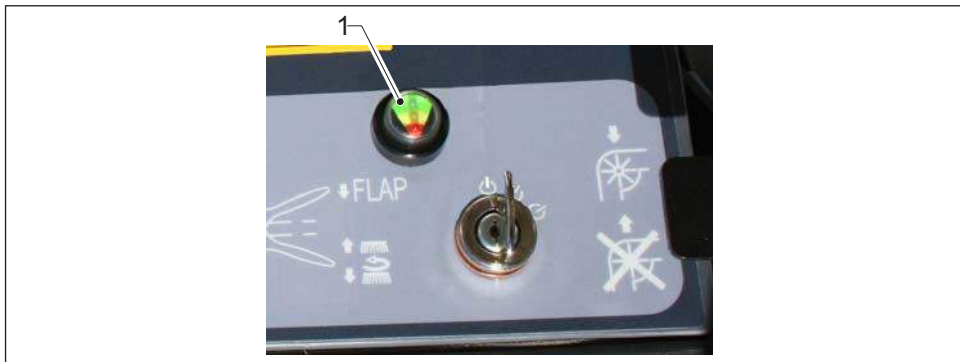

4.4 - MACHINE START

- Perform the preliminary checks (paragraph 4.3).
- Turn the starting key (1) until reaching position “I”, then on position “ON” until it reaches its end position.
Release the key once the machine motor has started.

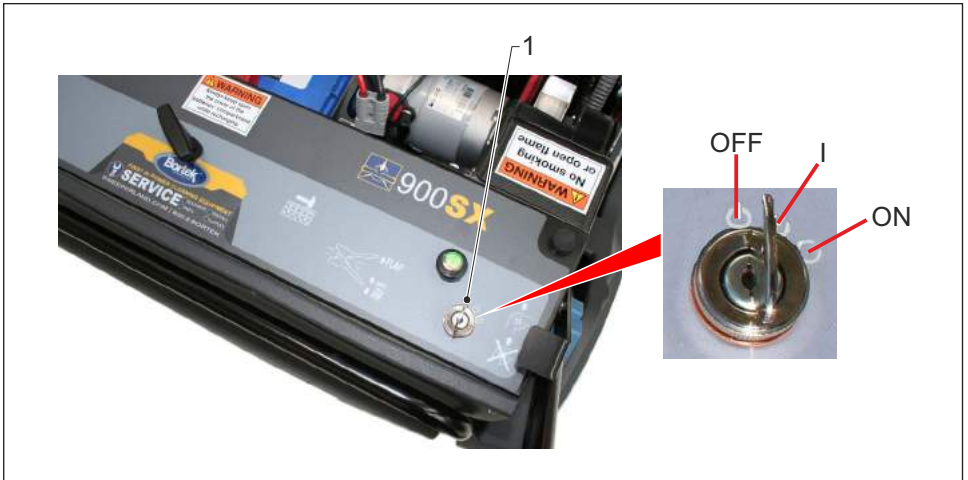

4.5 - CLEANING WORK

4.5.a - STARTING THE SWEEPING

- Lower level (1) to enable the dust suction.
- Press the unlocking (2) and release the levers (3) to lower and start the rotation of the left (OPT) and right brushes.
- Move the machine forward and sweep the ground by keeping the lever (5) pressed.

4.5.b - END OF SWEEPING AND MACHINE STOP

- Release the forward running control lever (5) and press the levers (3) and (4) to lift the brushes.
- Lift lever (1) to disable the dust suction.
- Turn the starting key (6) in position "OFF" to stop the motor.
- Use the control (7) to operate the filter shaker.

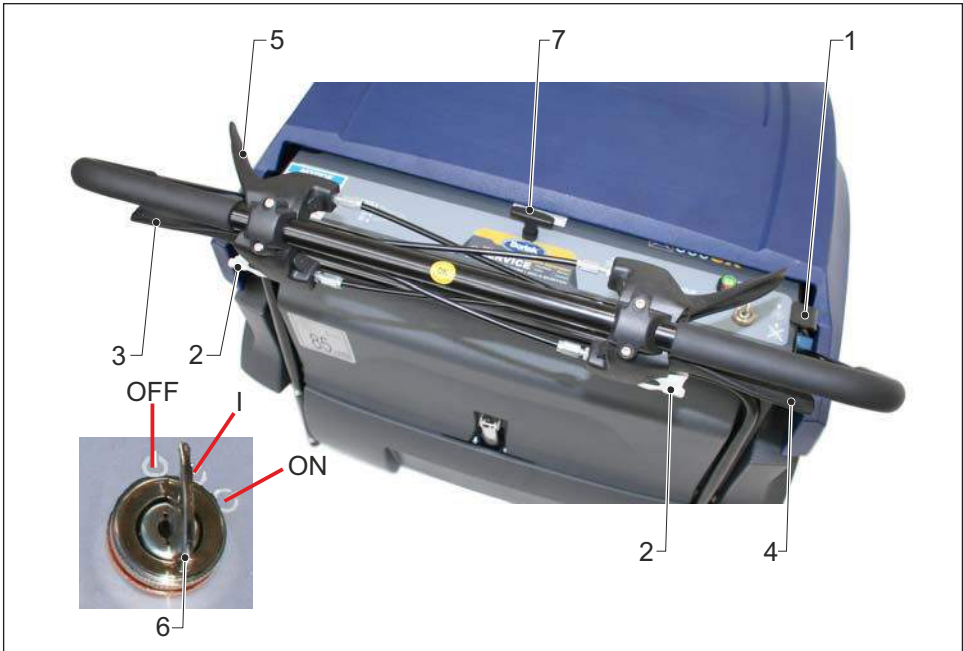

4.5.c - EMPTYING THE WASTE BOX

- Release the hook (1) and extract the waste box (2).
- Empty the box, then put it in back its housing correctly and lock it with the hook (1).



4.6 - BATTERY RECHARGE (OPT)



WARNING:

Charging the battery must be performed in rooms according to the regulations in force in the country of use.

CAUTION:

Read the enclosed documentation (if present) concerning the battery and the battery charger to use, making sure that the voltage supplied is correct.

- *Position the machine close to the battery charging area.*
- *Connect the outlet (1) of the battery charger (2) to the charging cable (3) supplied with the machine.*
- *Once the battery is charged, disconnect the cable (3).*

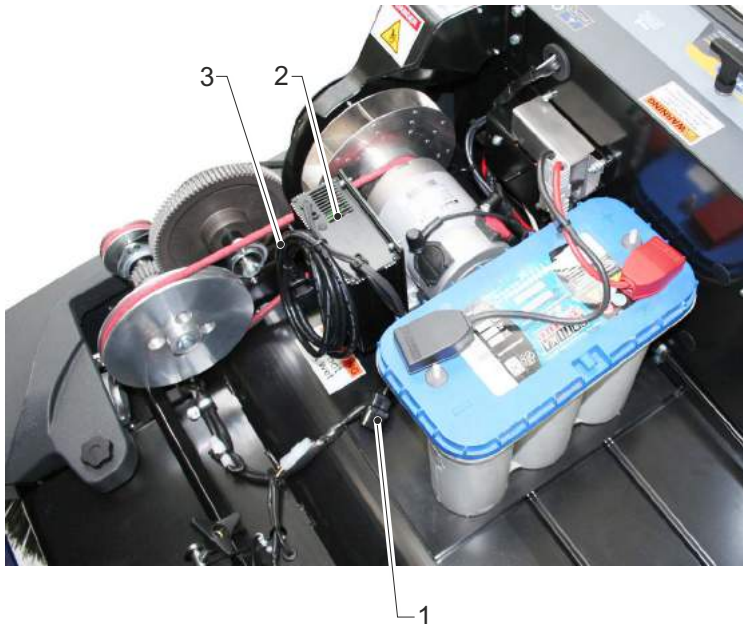

CHAPTER 5

MAINTENANCE

INDEX

5.1 - MAINTENANCE OPERATIONS	3
5.1.a - Maintenance preliminary operations.....	4
5.2 - DAILY MAINTENANCE	4
5.2.a - Cleaning the waste box with water.....	4
5.2.b - Checking for material wound on the brushes.....	4
5.3 - WEEKLY MAINTENANCE	5
5.3.a - Checking the wear of the waste box dust gaskets.....	5
5.3.b - Checking the wear of the main brush rubber dust askets.....	5
5.3.c - Checking the efficiency of the brushes.....	5
5.4 - PERIODICAL MAINTENANCE	6
5.4.a - Disassembling and cleaning the dust filter.....	6
5.4.b - Checking the wear of the driving belts.....	8
5.5 - EXTRAORDINARY MAINTENANCE	9
5.5.a - Machine cleaning.....	9
5.5.b - Adjusting the main brush.....	9
5.5.c - Replacing the main brush.....	10
5.5.d - Adjusting the side brushes.....	11

INDICE - INDEX

5.5.e - Replacing the side brushes **11**

5.5.f - Replacement of fuses..... **12**

5.1 - MAINTENANCE OPERATIONS

In order to maintain your machine in good condition, carry out the maintenance operations listed below.

Further to the maintenance operations described in this chapter there are also other operations that need to be carried out by the skilled technical personnel from the sales network. We hence advise you to apply to the sales network in order to agree upon a maintenance service being suitable to the machine.

Maintenance operations are of two types:

1) PLANNED MAINTENANCE

- *Daily maintenance (every 8 hours)*
- *Weekly maintenance (every 40 hours)*
- *Periodical maintenance*

2) EXTRAORDINARY MAINTENANCE



WARNING:

Maintenance operations must be carried out by skilled technical personnel or by authorised workshops. Always work in safety conditions by complying with the standards in force and by abiding by the safety rules for handling of working materials as well as the rules indicated in “chapter 1”.

CAUTION:

In case of use in dusty environments, at very low temperatures and for particularly heavy duties, it is necessary to reduce the interval between the various interventions of routine maintenance.

NOTICE:

The maintenance intervals are referred to the machine’s operating hours.

5.1.a - MAINTENANCE PRELIMINARY OPERATIONS

Before starting the maintenance operations, it is necessary to:

- *Position the machine on a plane surface and make sure that it cannot move accidentally.*
- *Turn off the machine and remove the ignition key.*
- *Visually signal that you are carrying out maintenance operations.*

**WARNING:**

Disconnect the battery before starting any operation on the electric system.

5.2 - DAILY MAINTENANCE**5.2.a - CLEANING THE WASTE BOX WITH WATER**

- *Extract the waste box, empty it and wash with running water.*
- *Wait until the box is perfectly dry and put it back in its housing.*

5.2.b - CHECKING FOR MATERIAL WOUND ON THE BRUSHES

- *Visually check the main and side brushes and make sure no material is wound on the brushes.*

**CAUTION:**

Always touch the brushes wearing special safety gloves to avoid any lesion caused by cutting material possibly present between the bristles.

5.3 - WEEKLY MAINTENANCE

5.3.a - CHECKING THE WEAR OF THE WASTE BOX DUST GASKETS

- Extract the waste box.
- Visually check the wear of the waste box dust gaskets (1).

CAUTION:

**Replace them if they are excessively damaged.
Apply to an authorized Assistance Service Center.**

5.3.b - CHECKING THE WEAR OF THE MAIN BRUSH RUBBER DUST GASKETS

- Visually check the wear status of the main brush rubber dust gaskets (2).
- These rubber gaskets must be replaced if they are excessively damaged. Therefore, first remove the screws and their nuts (3), then install new gaskets and fix them correctly with their screws and nuts.

5.3.c - CHECKING THE EFFICIENCY OF THE BRUSHES

- Visually check the efficiency of the main and side brushes (length and inclination of bristles).

NOTICE:

In case of adjustment and/or replacement, please see “paragraph 5.5”.

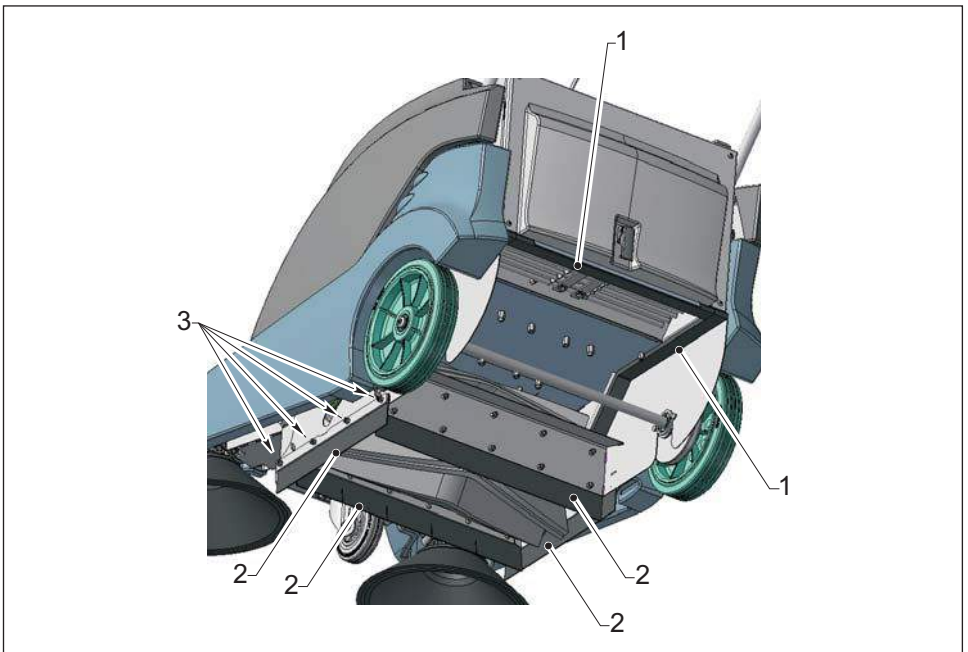

5.4 - PERIODICAL MAINTENANCE

Operation	every 200 hours (four-monthly)	every 500 hours (yearly)	CA	paragraph
Disassemble and clean the dust filter	•		•	5.4.a
Check / replace the electrical motor carbon brushes		•	•	-
Check the wear of the driving belts		•	•	5.4.b

CA: Authorized Technical Assistance Center

NOTICE:

It is recommended to contact an authorised service centre regarding the periodical maintenance operations.

5.4.a - DISASSEMBLING AND CLEANING THE DUST FILTER

- Extract the waste box.
- Unscrew the screws (2) and remove the cover giving access to the dust filter cover (1).
- Unscrew and remove the handle (3).
- Release the screws (4), then lower the dust filter (5) and extract it.

CAUTION: The filter may **ONLY** be cleaned with a dust suction unit, whereby the filter itself must be dry and its bags must be vacuumed one by one.

To avoid any damage during the cleaning process:

- **DO NOT** use mechanical methods (brushing, scraping, etc.).
- **DO NOT** wash the filter (in washing machine, by hand, etc.).
- **DO NOT** use cleaners.
- **DO NOT** use jets under pressure (air, water, cleaning solutions, etc.).

Replace the filter if it is fouled and/or damaged. Apply to an authorized Assistance Service Center.

- Reassemble the filter (5) and fasten it correctly with its screws (4).
- Put the cover (1) back in position, tighten the screws (2), screw the handle (3) and put the waste box in its lodging.

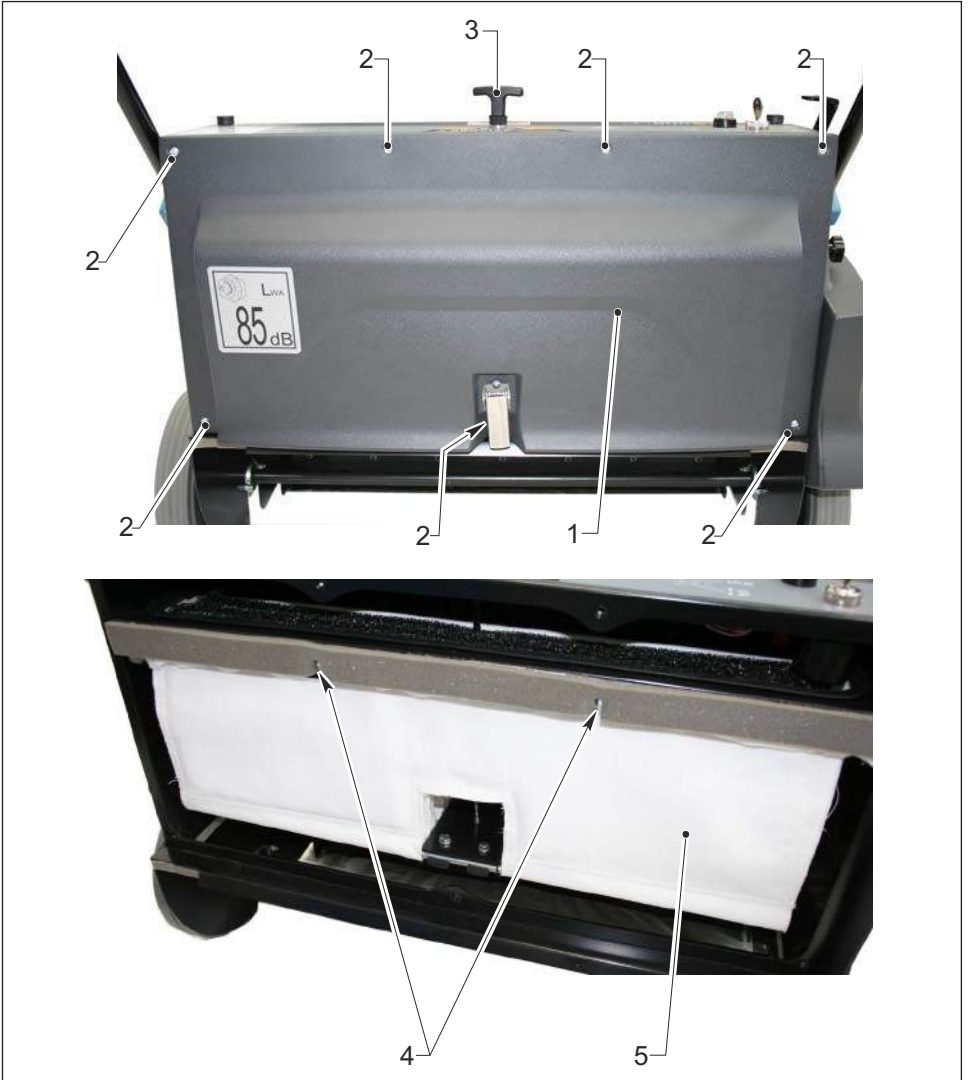

5.4.b - CHECKING THE WEAR OF THE DRIVING BELTS

- Lift the main cover.
- Visually check the wear of the driving belts (1).

CAUTION:

The belts must be replaced when they are frayed and/or worn out. Apply to an authorized Assistance Service Center.



5.5 - EXTRAORDINARY MAINTENANCE

Carry out the maintenance operations when the machine needs to be cleaned, adjusted and/or some worn out or failing part needs to be replaced (for example: to adjust the brushes, to replace a fuse, etc...).

5.5.a - MACHINE CLEANING

The cleaning of the machine depends on the use and on the work place.

Should the machine get in contact with strong agents such as salty water, fertilizers, chemical agents, cement, etc... it is necessary to carry out a more accurate cleaning possibly after any working cycle.

Preferably use compressed air, decalcified water and cold detergents.

5.5.b - ADJUSTING THE MAIN BRUSH

The impression left on the ground by the main brush (when rotating) must be approx. 30 mm wide. Otherwise, turn the handwheel (1) in one direction or the other to increase or reduce the pressure of the brush on the ground.

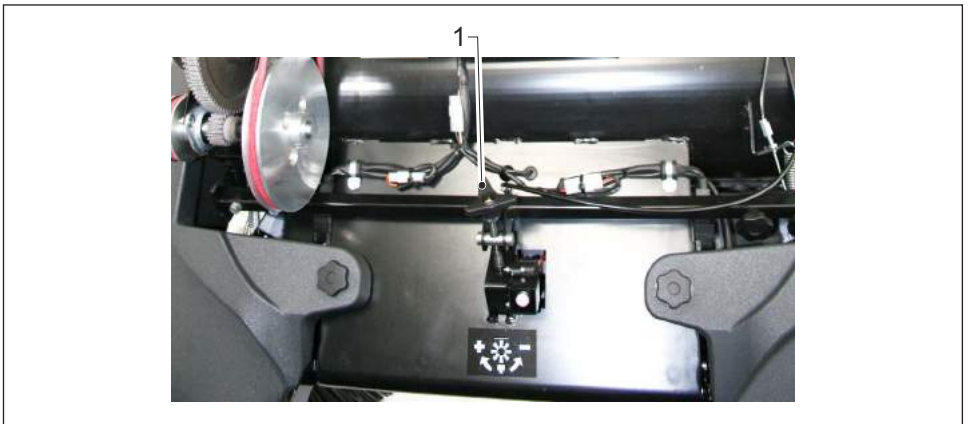

5.5.c - REPLACING THE MAIN BRUSH



CAUTION:

Always touch the brush wearing special safety gloves to avoid any lesion caused by cutting material possibly present between the bristles.

This brush must be replaced when the length of the bristles is less than 20 mm.

- *Lift the main cover.*
- *Unscrew both handwheels (1) and remove the side cover (2).*
- *Unscrew the four handwheels (1) and remove the brush cover (4).*
- *Extract the brush (5) and replace it. Assemble a new brush.*
- *Check its direction of rotation and make sure it is correct.*
- *Reassemble the cover (4).*
- *Make sure the brush grooves are inserted correctly in the teeth of the idle hub (6), then fasten the cover with the handwheels (3).*
- *Reassemble the side cover (2) and tighten the handwheels (1).*

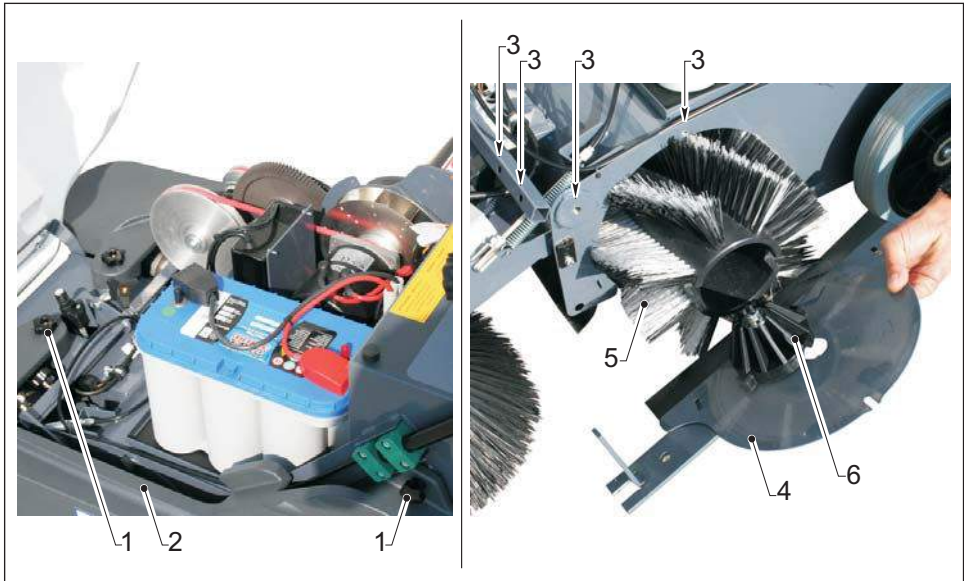

5.5.d - ADJUSTING THE SIDE BRUSHES

The brush must touch the ground with its front and outer part.
Otherwise screw or unscrew the adjustment separator (1).

5.5.e - REPLACING THE SIDE BRUSHES



CAUTION:

Always touch the brushes wearing special safety gloves to avoid any lesion caused by cutting material possibly present between the bristles.

These brushes must be replaced when the length of the bristles is less than 50 mm.

- Unscrew the retainer (2) and remove it.
- Extract the brush (3) and replace it. Assemble a new brush, then insert the retainer again and hook it up.

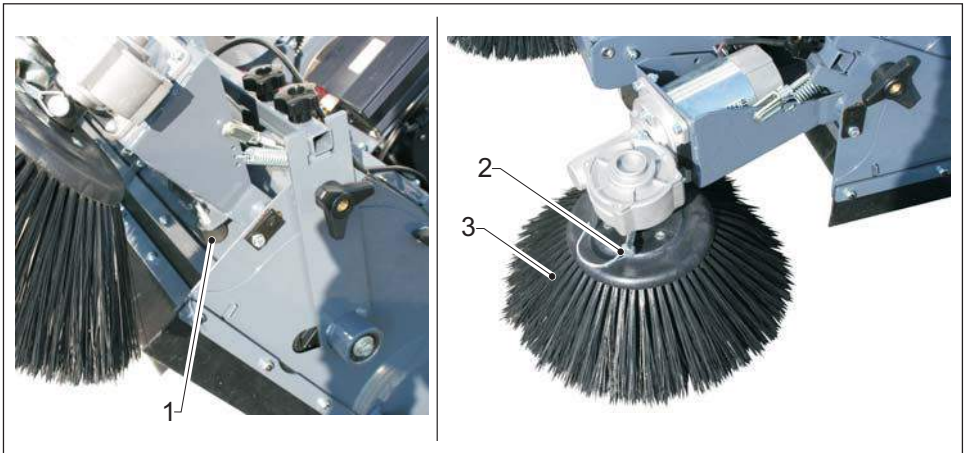

5.5.f - REPLACEMENT OF FUSES

CAUTION:

*Never replace a broken fuse with wire or other salvage.
Always use only an intact fuse with the same amperage.*

Never replace a broken fuse with another one having a superior amperage; fire danger.

Before replacing a fuse, stop all the machine's functions and remove the ignition key.

Should a replaced fuse burn over again, call an authorized assistance center.

Lift the main cover to gain access to the fuses and other electrical parts.

F1= Right brush fuse 7,5A

F2= Left brush fuse 7,5A OPT)

F4= Main system fuse (control circuit) 3A

F5= Main fuse (power) 60A

TG= Main remote control switch

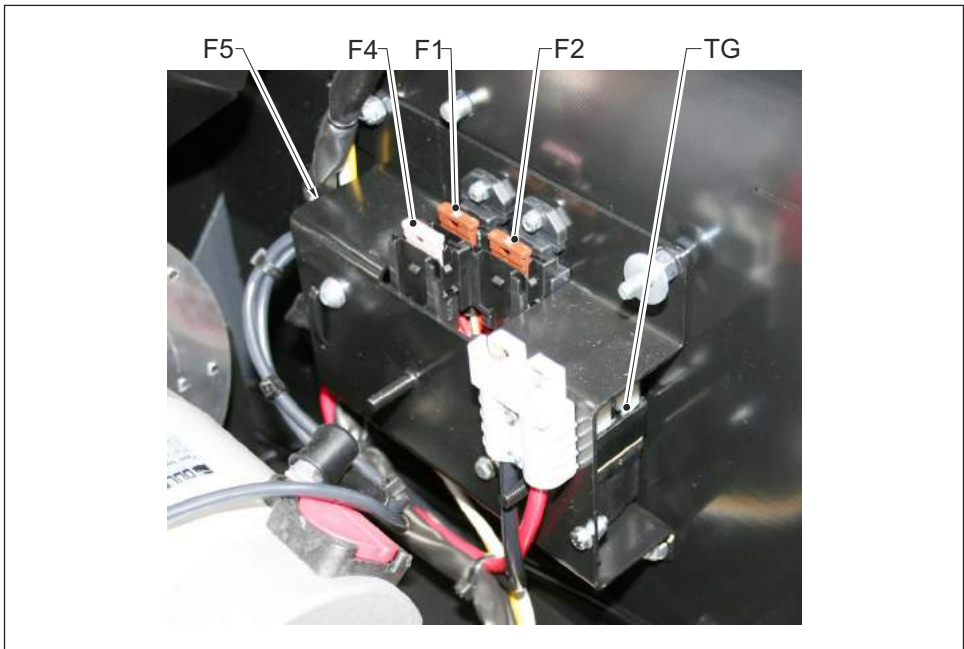



HAMMERHEAD®



450**RS**



500**RS** GEN II



500**RSX**



500**SS** GEN II



600**SS**



650**RS**



750**RS**



550**RDX**



650**RDX**



700**RSX**



750**RDX**



950**MS**



870**SR**



1100**SRX**

HEADQUARTERS

4713 Gettysburg Road
Mechanicsburg, PA 17055 USA

CONTACT US

800.6.Bortek

717.737.7591

Orders@BortekIndustries.com

BortekIndustries.com/[CUSTOMERLINK](#)

SWEEPERLAND.COM

The complete family of
power cleaning machines.
Only Available at Bortek.