

SW4000



Service Manual

Advance SW4000 Battery - 9084403010

Nilfisk SW4000 Battery - 9084400010

Nilfisk SW4000 Petrol - 9084401010

Nilfisk SW4000 LPG - 9084402010

Advance (SW4000 BR) - 9084407010 (LPG)



English

2013-04 Form No. 1464811000

Table of Contents

Table of Contents	2
General Information	5
Machine General Description	5
Service Manual Purpose and Field of Application	5
Other Reference Manuals	5
Conventions.	6
Service and Spare Parts	6
Serial Number Label	6
Safety	7
Visible Symbols On The Machine	7
Symbols	7
General Instructions	7
Machine Lifting.	11
Machine Transportation	11
Machine Nomenclature (know your machine) (SW4000 Battery)	12
Control Panel (SW4000 Battery)	15
Machine Nomenclature (know your machine) (SW4000 Petrol/LPG)	16
Control Panel (SW4000 Petrol/LPG)	19
Service and Diagnostic Equipment	20
Technical Data	21
Dimensions	24
Maintenance	25
Scheduled Maintenance Table (SW4000 Battery)	25
Scheduled Maintenance Table (SW4000 Petrol/LPG)	26
Chassis System	27
Chassis (main parts)	27
Control System	28
Functional Description	28
Dashboard Electronic Board Specifications	29
Wiring Diagram (SW4000 Battery)	31
Wiring Diagram (SW4000 Petrol/LPG)	33
Component Locations	35
Troubleshooting	36
Dashboard Electronic Error Codes	37
Removal and Installation	42
Dust Control System	43
Functional Description	43
Wiring Diagram	43
Component Locations	44
Maintenance and Adjustments	45
Troubleshooting	47
Removal and Installation	48
Specifications	53
Dust Guard System	54
Functional Description	54
Wiring Diagram	54
Component Locations	55
Maintenance and Adjustments	56
Troubleshooting	58
Removal and Installation	59
Specifications	61

Electrical System	62
Functional Description	62
Fuses	63
Relay/Electromagnetic Switch/Diodes	64
Wiring Diagram (SW4000 Battery)	65
Wiring Diagram (SW4000 Petrol/LPG)	66
Component Locations (SW4000 Battery)	67
Component Locations (SW4000 Petrol/LPG)	68
Maintenance and Adjustments	70
Fuse Check/Replacement (SW4000 Battery)	75
Troubleshooting	77
Removal and Installation	78
General Wiring Diagram (SW4000 Battery)	83
General Wiring Diagram (SW4000 Petrol - LPG).	86
Specifications	89
Engine System - Petrol.	90
Functional Description	90
Wiring Diagram	90
Component Locations	91
Maintenance and Adjustments	92
Troubleshooting	99
Removal and Installation	100
Specifications	103
Engine System - LPG	104
Functional Description	104
Wiring Diagram	104
Component Locations	105
Maintenance and Adjustments	107
Troubleshooting	120
Removal and Installation	121
Specifications	132
Hopper System	133
Functional Description	133
Wiring Diagram	134
Hydraulic diagram	135
Component Locations	136
Maintenance and Adjustments	138
Troubleshooting	139
Removal and Installation	140
Specifications	151
Optional and Accessories	152
Steering System.	154
Functional Description	154
Component Locations	155
Removal and Installation	156
Main Broom System	159
Functional Description	159
Wiring Diagram	159
Component Locations	160
Maintenance and Adjustments	162
Troubleshooting	168
Removal and Installation	169

Side Broom System	187
Functional Description	187
Wiring Diagram	187
Component Locations	188
Maintenance and Adjustments	189
Troubleshooting	190
Removal and Installation	191
Specifications	199
Wheel System, Non-Traction	200
Component Locations	200
Wheel System, Traction	202
Functional Description	202
Component Locations	204
Troubleshooting	206
Drive System Electronic Board Error Codes Table	207
Drive System Electronic Board Parameter Table	208
Removal and Installation	212
Specifications	232

General Information

Machine General Description

The SW4000 is a “ride-on” industrial machine designed to clean/sweep floors, in civil or industrial environments, in one pass. The machine can be supplied in one of the following version:

- with a rechargeable battery, installed on the machine (**SW4000 Battery**)
- with a battery charged by a petrol engine, both installed on the machine (**SW4000 Petrol**)
- with a battery charged by a LPG gas engine (**SW4000 LPG**)

The machine is equipped with one main cylindrical broom, and one or two side disc brooms.

The rear hopper and a vacuum system allow for dust and dirt collection.

The hopper is equipped with a lifting system to discharge the collected debris.

Service Manual Purpose and Field of Application

The Service Manual is a technical resource intended to help service technicians when carrying out maintenance and repairs on the SW4000, to guarantee the best cleaning performance and a long working life for the machine.

Please read this manual carefully before performing any maintenance and repair procedure on the machine.

Other Reference Manuals

Model	Product Code	User Manual	Spare Parts List
SW4000 Battery - Nilfisk	9084400010	1464809000	1464810000
SW4000 Petrol - Nilfisk	9084401010	1464815000	1464816000
SW4000 LPG - Nilfisk	9084402010		
SW4000 Battery - Advance	9084403010	1464818000	1464819000

Assembly Instructions	Instruction Code	Machines concerned
MTR/250 NON-MARKING MOTOR RING	1465241000	SW4000 Battery Advance – SW4000 Battery/Petrol/LPG Nilfisk
WORKING LIGHT KIT	1465245000	
ROOF COVER KIT	1465247000	
LEFT BROOM KIT	1465242000	
PIVOTING LIGHT KIT	1465248000	
NON-MARKING SKIRT KIT	1465241000	
LEFT ARMREST KIT	1465249000	
PROTECTION ROOF KIT	1465246000	
24V DUST GUARD SYSTEM KIT	1465244000	
SAFETY BELT KIT	1465248000	
RIGHT SIDE BROOM SHIELD KIT	1465243000	
LEFT SIDE BROOM SHIELD KIT	1465243000	
MTR/250 NON-MARKING MOTOR RING	1465241000	
WORKING LIGHT KIT	1465245000	

These manuals are available at:

- Local Nilfisk-Advance Retailer

- Nilfisk-Advance website: www.nilfisk.com - www.advance-us.com

Conventions

Forward, backward, front, rear, left or right are intended with reference to the operator’s position when driving.

Service and Spare Parts

Service and repairs must be performed only by authorised personnel or Nilfisk Service Centers. The authorised personnel is trained directly at the manufacturer’s premises and has original spare parts and accessories. Contact Nilfisk Retailer indicated below for service or to order spare parts and accessories, specifying the machine model and serial number.

(Apply Retailer label here)

Serial Number Label

The machine model name and serial number are marked on the plate (see the example to the side). Product number and year of production are marked on the same plate. This information is useful when requiring machine spare parts. Use the following table to write down the machine identification data.



Model: Sweeper SW4000	Serial No:
Prod. Nr: 9084403010	Date code:
GVW: 757 kg / 1669 lb IPX3	LpA = 65 dB(A)
PWR/A = 2,0 kW	Battery 24 Vdc
Type E Floor cleaning machine	
Conform to: UL STD 585	
Certified to: CSA STD C22.2 N 68-92	 15% 
 Advance <small>A Nilfisk-Advance Brand</small>	"Made in Italy" Nilfisk-Advance, Inc. Plymouth, MN, USA www.advance-us.com







P200082

MACHINE model
PRODUCT code
MACHINE serial number
ENGINE model
ENGINE serial number

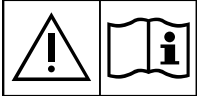
Safety

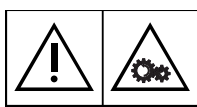
The following symbols indicate potentially dangerous situations. Always read this information carefully and take all necessary precautions to safeguard people and property.

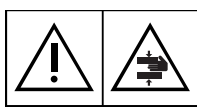
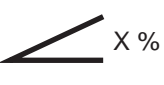
Visible Symbols On The Machine

	WARNING! Carefully read all the instructions before performing any operation on the machine.		WARNING! Hot parts, danger of burns.
	DANGER! Internal combustion engine. Do not inhale exhaust gas fumes. Carbon monoxide (CO) can cause brain damage or death.		WARNING! Moving parts.
	WARNING! Do not wash the machine with direct or pressurized water jets.		WARNING! Moving parts. Danger of crushing.
	WARNING! Do not use the machine on slopes with a gradient exceeding the specifications.		WARNING! Parts under voltage. Presence of corrosive fluids.

Symbols



Danger! It indicates a dangerous situation with risk of death for the operator.



Warning! It indicates a potential risk of injury for people or damage to objects.



Caution! It indicates a caution related to important or useful functions.



Note: It indicates a remark related to important or useful functions.

General Instructions

Specific warnings and cautions to inform about potential damages to people and machine are shown below.



Warning! Make sure to follow the safety precautions to avoid situations that may lead to serious injuries.

(For SW4000 Battery/Petrol/LPG)

- Before performing any maintenance, repair, cleaning or replacement procedure remove the ignition key, engage the parking brake and disconnect the battery (For SW4000 Petrol/LPG - Disconnect the battery connector).
- This machine must be used by properly trained operators only.

- Sharp turns must be made at slowest possible speed. Avoid: abrupt turns on incline, turns when the hopper is lifted.
- Do not lift the hopper when the machine is on incline. The machine loses stability on incline or when the hopper is full.
- Keep the batteries away from sparks, flames and incandescent material. During the normal operation explosive gases are released.
- Do not wear jewels when working near electrical components.
- Do not work under the lifted machine without supporting it with safety stands.
- When working under the open hood, ensure that it cannot be closed by accident.
- Do not operate the machine near toxic, dangerous, flammable and/or explosive powders, liquids or vapors: This machine is not suitable for collecting dangerous powders.
- (For WET batteries only). Keep the battery away from sparks, flames and incandescent material. During the normal operation explosive gases are released.

(For SW4000 Petrol/LPG)

- Carbon monoxide (CO) can cause brain damage or death.
- The internal combustion engine of this machine can emit carbon monoxide.
- Do not inhale exhaust gas fumes.
- Only use indoors when adequate ventilation is provided, and with the help of an assistant.

(For SW4000 Petrol/LPG)

- Be careful: fuel is highly flammable.
- Do not smoke or bring naked flames in the area where the machine is refuelled or where the fuel is stored.
- Refuel outdoors or in a well-ventilated area, with the engine off.
- Turn off the engine and let it cool down for a few minutes, then remove the fuel tank plug.
- Leave at least a space of 4 cm in the filler to allow the fuel to expand.
- After refuelling, check that the fuel tank cap is firmly closed.
- If any fuel is spilled while refuelling, clean the tank area and allow the vapors to evaporate before starting the engine.
- Do not let fuel come into contact with the skin; do not breathe fuel vapors. Keep out of reach of children.
- Do not tilt the engine too much to avoid fuel spillage.
- When moving the machine, the fuel tank must not be full and the fuel valve must be closed.
- Do not lay any object on the engine.
- Stop the engine before performing any procedure on it. To avoid any incidental start, disconnect the spark plug cap or disconnect the battery negative terminal.
- See also the SAFETY RULES in the Engine Manual, which is to be considered an integral part of this Manual.
- (For LPG version). Do not use the machine in case of gas leaks. Disconnect the fuel hose and replace the LPG tank. If the gas leak persists, disconnect the fuel hose and contact the Nilfisk-Advance Service Center.

(For SW4000 Battery)

- (For WET batteries only). Battery charging produces highly explosive hydrogen gas. Keep the battery cover open during battery charging and perform this procedure in well-ventilated areas and away from naked flames.



Warning! *Make sure to follow the safety precautions to avoid situations that may lead to serious injuries, damages to materials or equipments.*

(For SW4000 Battery/Petrol/LPG)

- Carefully read all the instructions before performing any maintenance/repair procedure.
- When working near the hydraulic system, always wear protective clothes and safety glasses.
- Pay attention to hot parts when working near the engine, the muffler, the manifold and the cooler.
- This machine is not intended for use by persons (including children) with reduced physical, sensory or mental capabilities, or lack of experience and knowledge, unless they have been given supervision or instruction concerning use of the machine by a person responsible for their safety. Children should be supervised to ensure that they do not play with the machine.
- Close attention is necessary when used near children.
- Use only as shown in this Manual. Only Nilfisk-Advance recommended accessories must be used.
- Check the machine carefully before each use, always check that all the components have been assembled before use. If the machine is not perfectly assembled it can cause damages to people and properties.
- Take all necessary precautions to prevent hair, jewels and loose clothes from being caught by the machine moving parts.
- To avoid any unauthorized use of the machine, remove the ignition key.
- Do not leave the machine unattended without being sure that it cannot move independently.
- Do not use the machine on slopes with a gradient exceeding the specifications.
- Do not tilt the machine more than the angle indicated on the machine itself, in order to prevent instability.
- Use only brooms supplied with the machine or those specified in the User Manual. Using other brooms could reduce safety.
- Before using the machine, close all doors and/or covers as shown in the User Manual.
- Do not wash the machine with direct or pressurised water jets, or with corrosive substances.
- Use the machine only where a proper lighting is provided.
- Working lights have to be used only to enhance visibility on the floor to be cleaned, but they do not authorize anyone to use the sweeper in dark environments.
- If the machine is to be used where there are other people besides the operator, it is necessary to install the pivoting light.
- While using this machine, take care not to cause damage to people or objects.
- Do not bump into shelves or scaffoldings, especially where there is a risk of falling objects.
- Do not lean liquid containers on the machine, use the relevant can holder.
- The storage temperature must be between 0°C and +40°C.
- The machine working temperature must be between 0°C and +40°C.
- The humidity must be between 30% and 95%.
- Always protect the machine against the sun, rain and bad weather, both under operation and inactivity condition. Store the machine indoors, in a dry place. This machine must be used in dry conditions, it must not be used or kept outdoors in wet conditions.
- Do not use the machine as a means of transport, or for pushing/towing.

- The machine maximum capacity, operator's weight not included, is 100 kg (the weight of waste).
- In case of fire, use a powder fire extinguisher, not a water one.
- Adjust the operation speed to suit the floor conditions.
- Avoid sudden stops when the machine is going downhill. Avoid sharp turns. Drive at slow speed when going downhill.
- This machine cannot be used on roads or public streets.
- Do not tamper with the machine safety guards.
- Follow the routine maintenance procedures scrupulously.
- Do not allow any object to enter into the openings. Do not use the machine if the openings are clogged. Always keep the openings free from dust, hairs and any other foreign material which could reduce the air flow.
- (Only for versions equipped with DustGuard™ system). Pay attention during machine transportation when temperature is below freezing point. The water in the tank or in the hoses could freeze and seriously damage the machine.
- Do not remove or modify the plates affixed to the machine.
- When the machine is to be pushed for service reasons (lack of fuel, engine break-down, etc.), the speed must not exceed 4 km/h.
- In case of machine malfunctions, ensure that these are not due to lack of maintenance. If necessary, request assistance from the authorised personnel or from an authorised Service Center.
- If parts must be replaced, require ORIGINAL spare parts from an Authorised Dealer or Retailer.
- To ensure machine proper and safe operation, the scheduled maintenance shown in the relevant chapter of this Manual, must be performed by the authorised personnel or by an authorised Service Center.
- (For WET batteries only). When lead batteries (WET) are installed on this machine, do not tilt the machine more than 30° from its horizontal position to prevent the highly corrosive acid to leak out of the batteries. If the machine must be tilted to perform any maintenance procedure, remove the batteries.
- The machine must be disposed of properly, because of the presence of toxic-harmful materials (batteries, oils, etc.), which are subject to standards that require disposal in special centres (see the User Manual).

(For SW4000 Petrol/LPG)

- While the engine is running, the silencer warms up; do not touch the silencer when it is hot to avoid burns or fires.
- Running the engine with an insufficient quantity of oil can seriously damage the engine. Check the oil level with the engine off and the machine on a level surface.
- Never run the engine if the air filter is not installed, because the engine could be damaged.
- Technical service procedures on the engine must be performed by an authorised Dealer.
- Only use original spare parts or parts of matching quality for the engine. Using spare parts of lower quality can seriously damage the engine.
- See also the SAFETY RULES in the Engine Manual, which is to be considered an integral part of this Manual.

(For SW4000 Battery)

- Before using the battery charger, ensure that frequency and voltage values, shown on the machine serial number plate, match the electrical mains voltage.
- Do not pull or carry the machine by the battery charger cable and never use the battery charger cable as a handle. Do not close a door on the battery charger cable, or pull the battery charger cable around sharp edges or corners. Do not run the machine on the battery charger cable.
- Keep the battery charger cable away from heated surfaces.

- Do not use the machine if the battery charger cable or plug is damaged. If the machine is not working as it should, has been damaged, left outdoors or dropped into water, return it to the Service Center.
- Before performing any maintenance procedure, disconnect the battery charger cable from the electrical mains to avoid any risk of fire, electric shock or injuries.
- Do not smoke while charging the batteries.

Guide lines to bacteria control and other dangers coming from the presence of microbes in the Dust-Guard™ system.

To prevent the operators and other people from developing infections caused by microbes and Legionella that may flourish in the dust guard system, take the following precautions:

- If possible, fill the tank with cold water (< 20°C).
- DO NOT use stagnant water to fill the tank.
- DO NOT use recycled water, undrinkable water or water that has been in contact with the soil.
- Adjust and turn the nozzles towards the floor only, from preventing possible inhaling.
- Do not store the machine outdoors or near sources of heat.
- Do not over-fill the tank. Fill the tank sufficiently so that it can be emptied by using the system.
- Empty the tank every 10 hours or once a week, according to the use.
- If the machine is not used for more than one week, empty the tank completely, and let it dry.
- If the tank cannot be cleaned regularly, consider using a biocide that can kill or exert a controlling effect on Legionella bacteria. Biocide must be chosen according to the local regulations and must be used according to the relevant instructions and cautions, to avoid that the personnel gets affected by dangerous chemical substances.
- If chemical products have to be used in the water tank, it is mandatory to apply the relevant information and caution labels of the product.

Machine Lifting



Warning! Do not work under the lifted machine, if it is not securely fixed.

Machine Transportation



Warning! Before transporting the machine, make sure that:

All covers are closed.

The tanks are empty.

The battery connector is disconnected.

The machine is securely fastened to the means of transport.

Machine Nomenclature (know your machine) (SW4000 Battery)

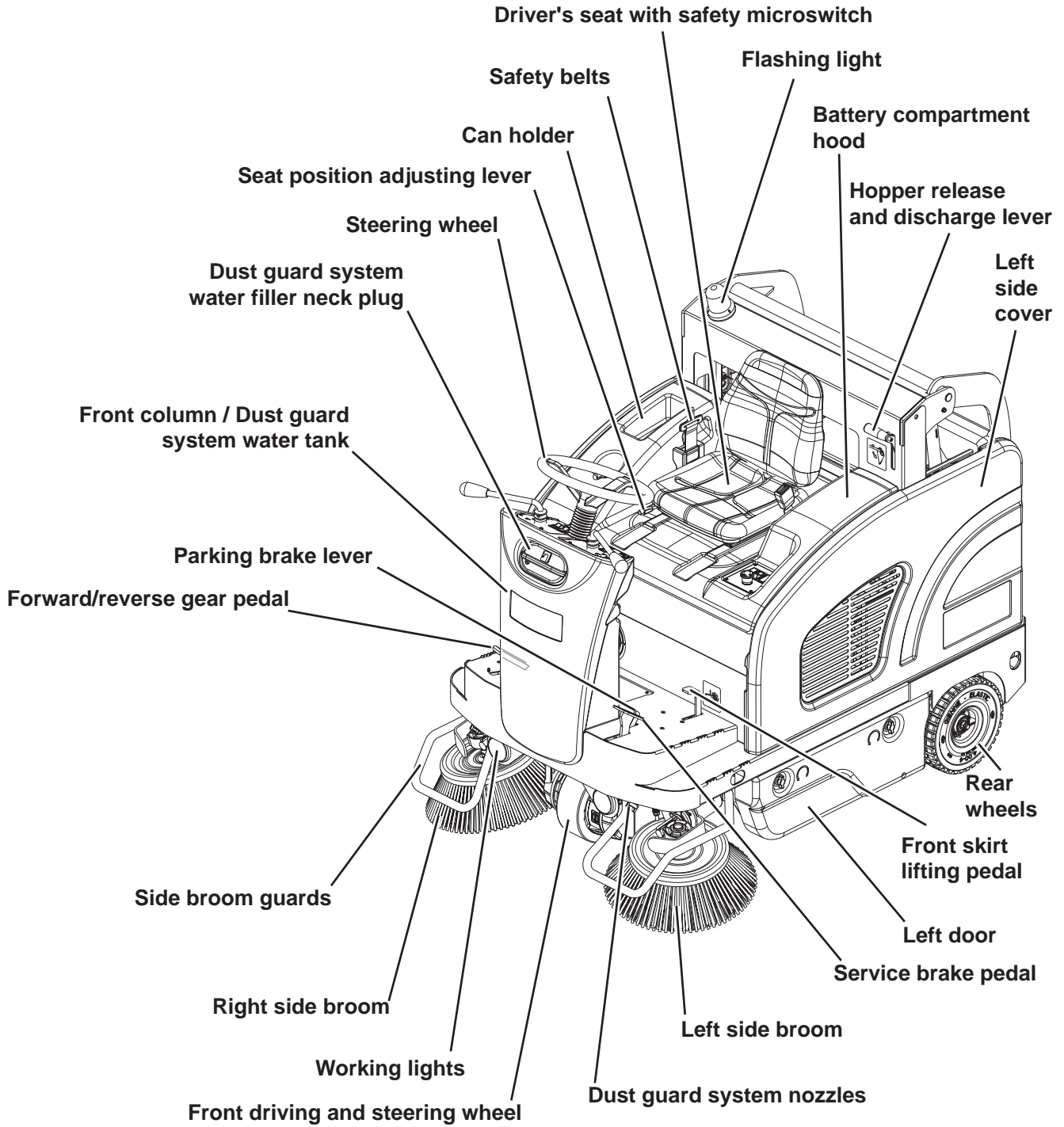

Machine Nomenclature (SW4000 Battery) (Continues)

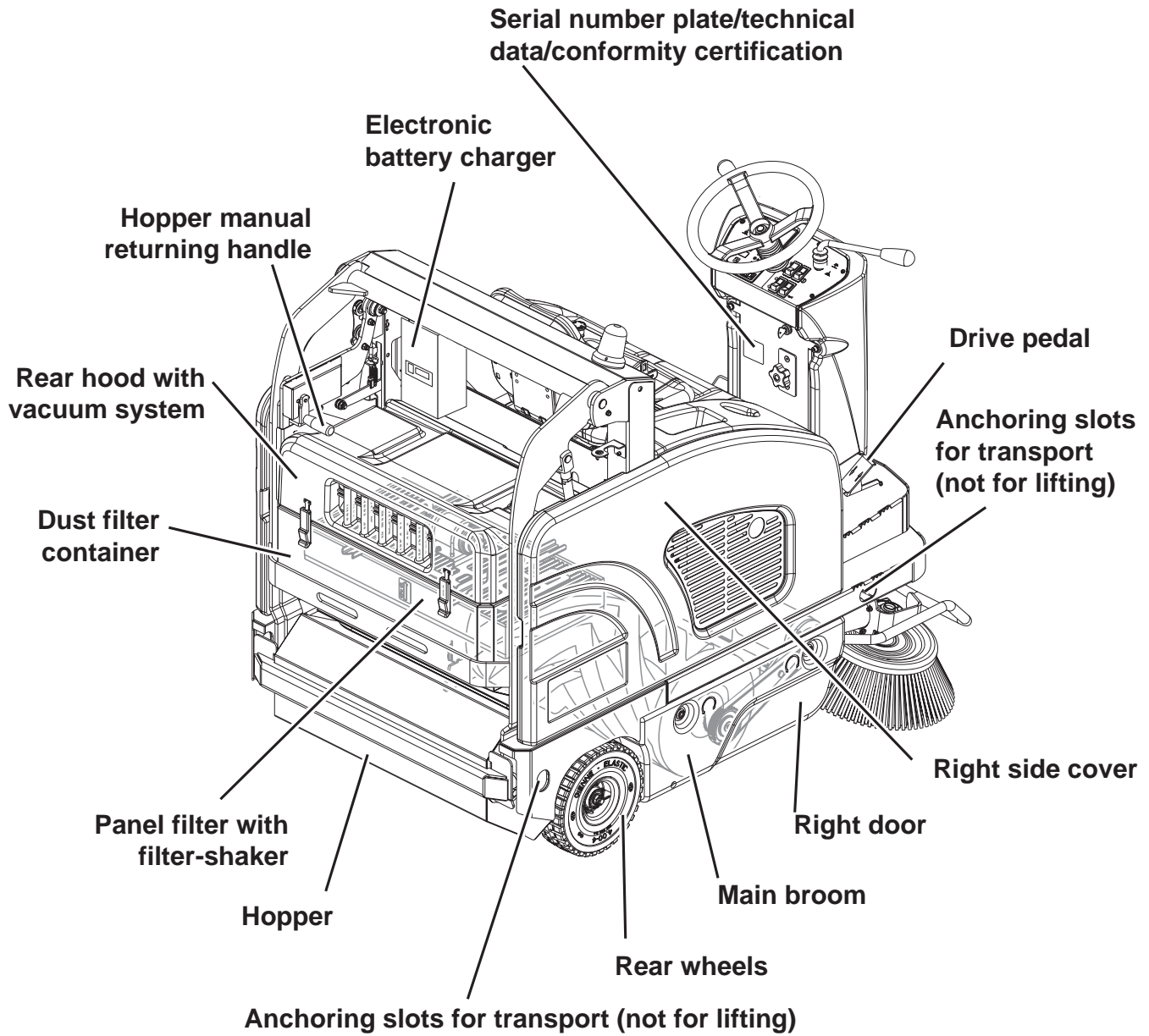

Machine Nomenclature (SW4000 Battery) (Continues)

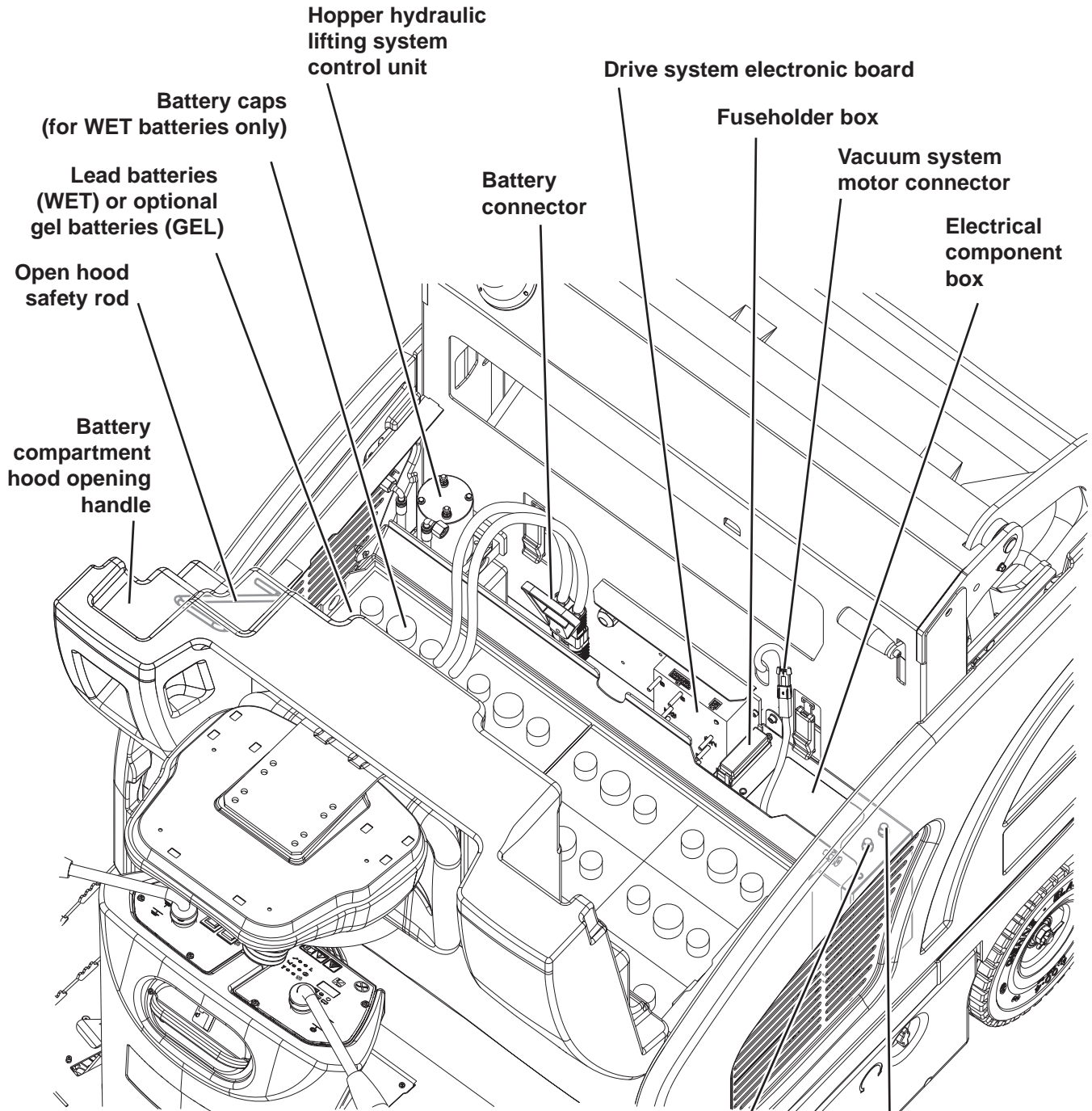

Battery connection diagram

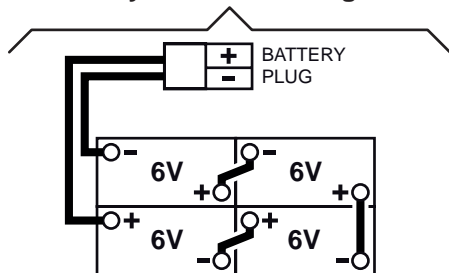

Control Panel (SW4000 Battery)

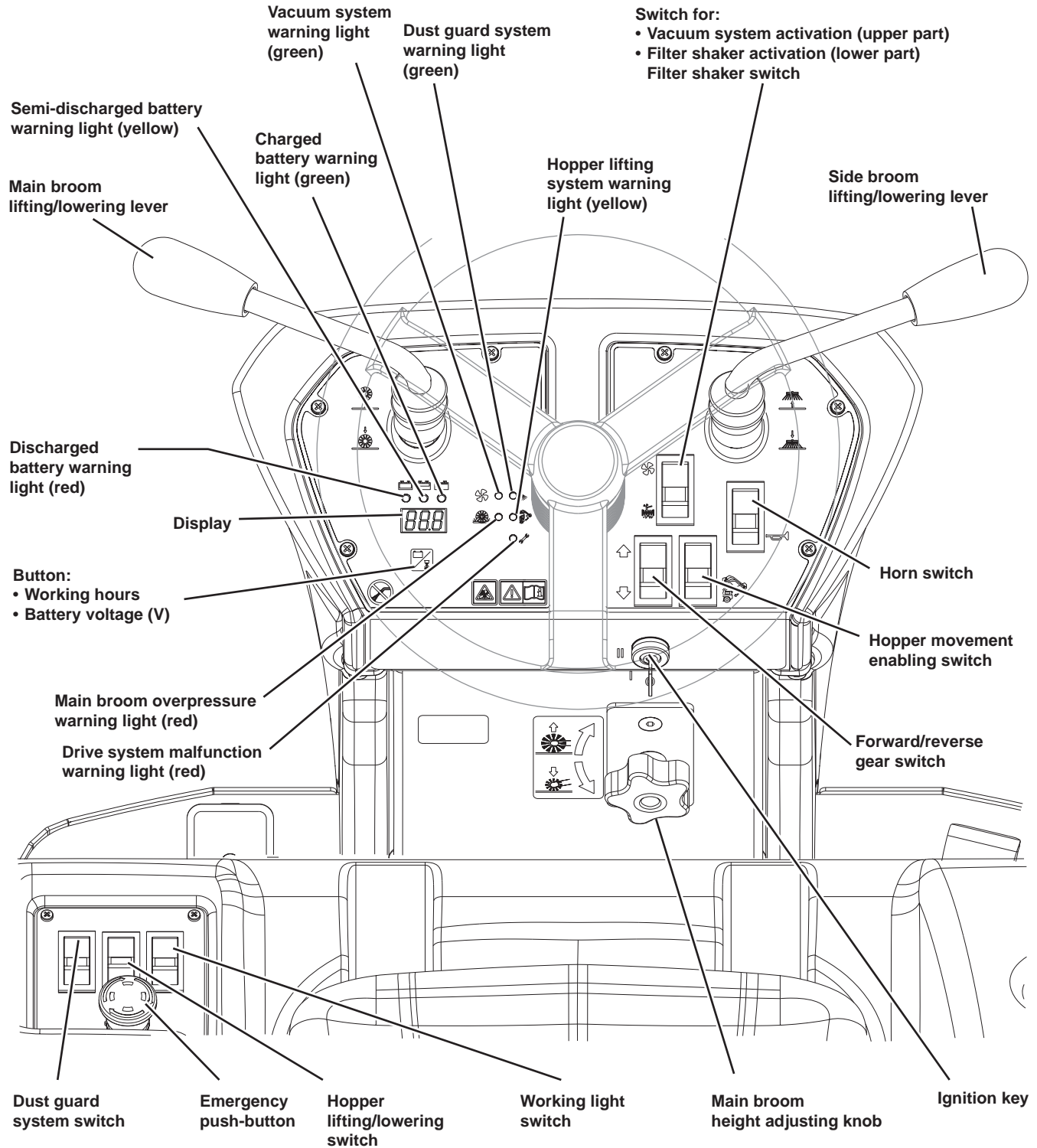

Machine Nomenclature (know your machine) (SW4000 Petrol/LPG)

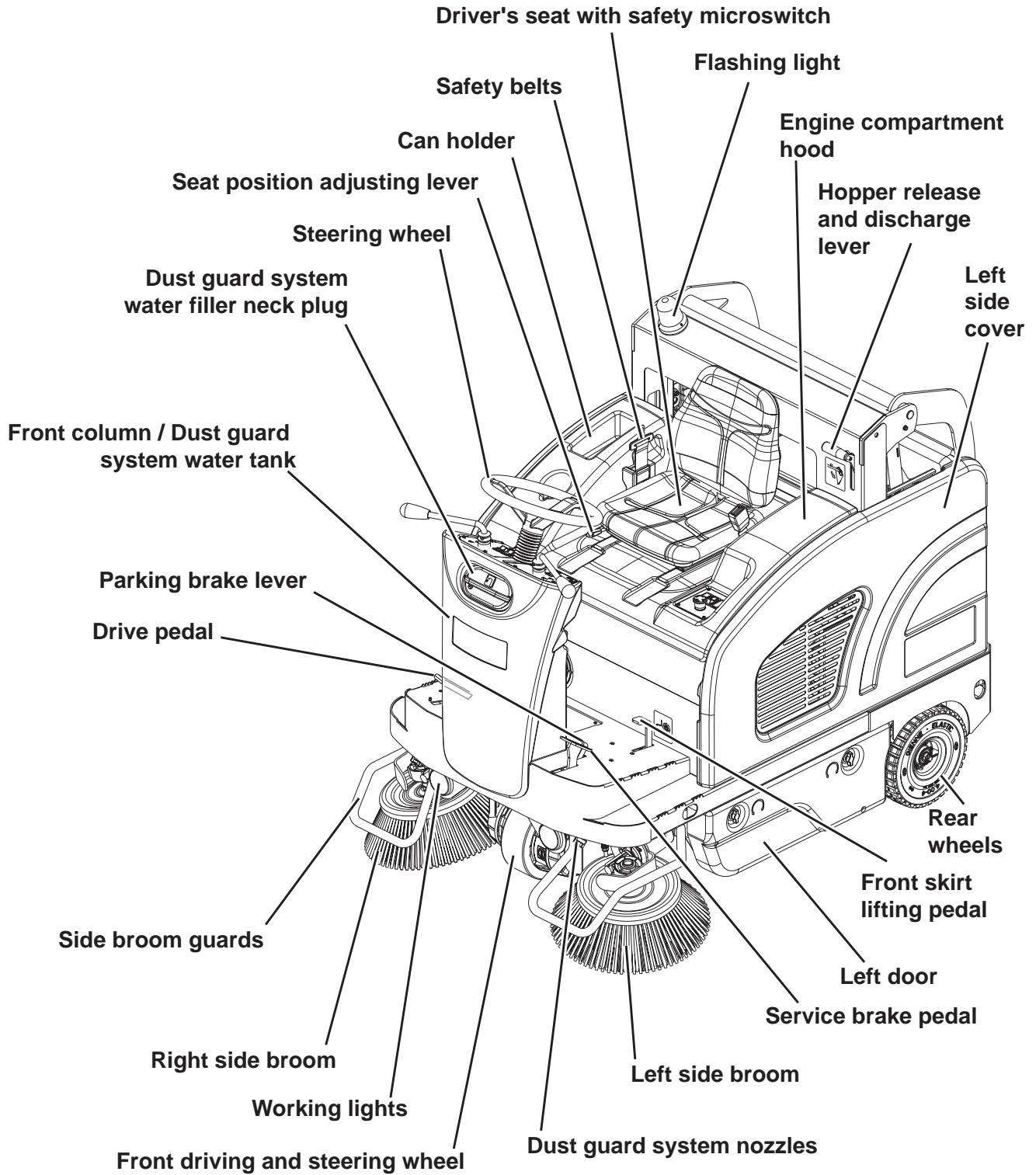

Machine Nomenclature (SW4000 Petrol/LPG) (Continues)

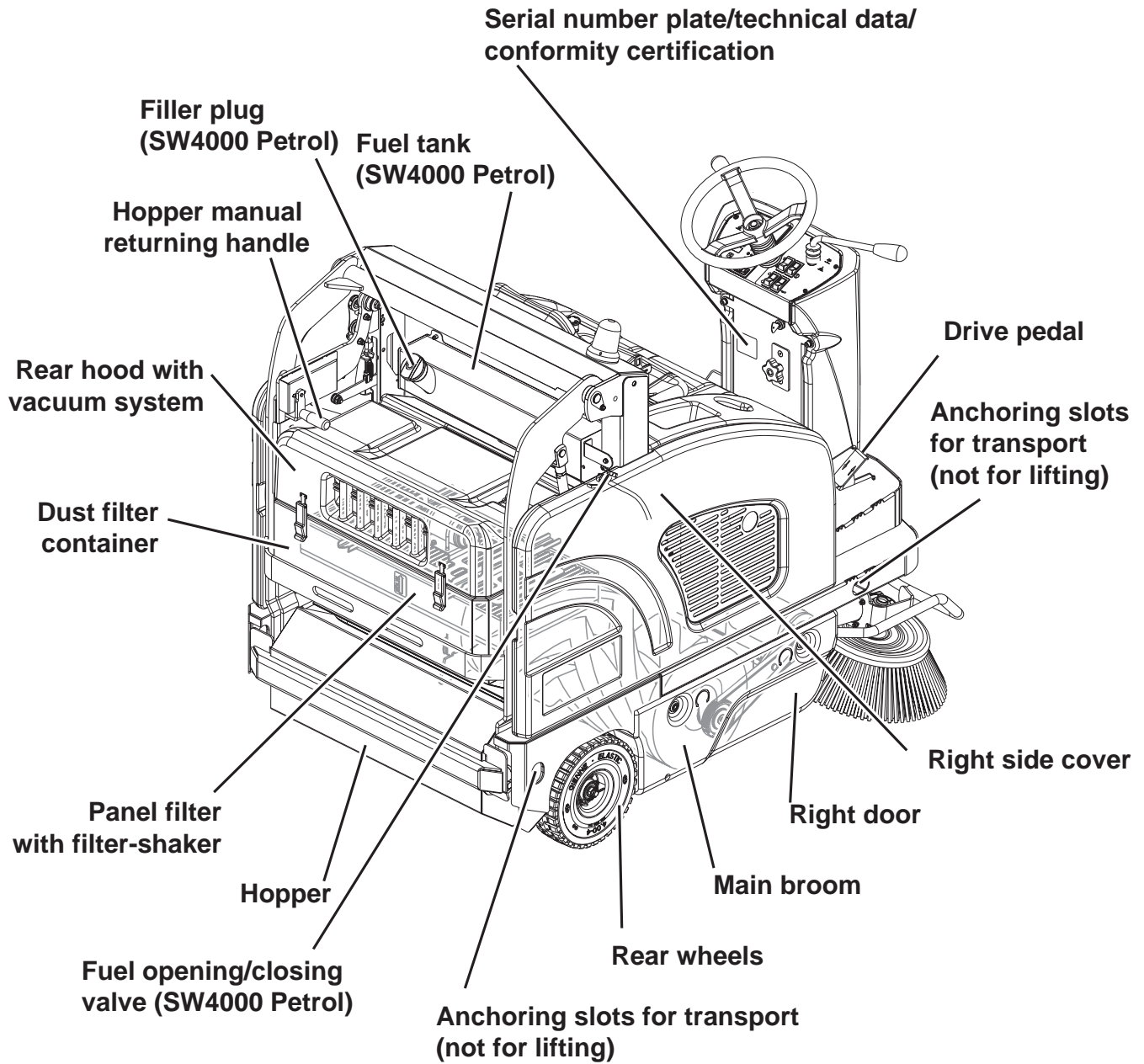

Machine Nomenclature (SW4000 Petrol/LPG) (Continues)

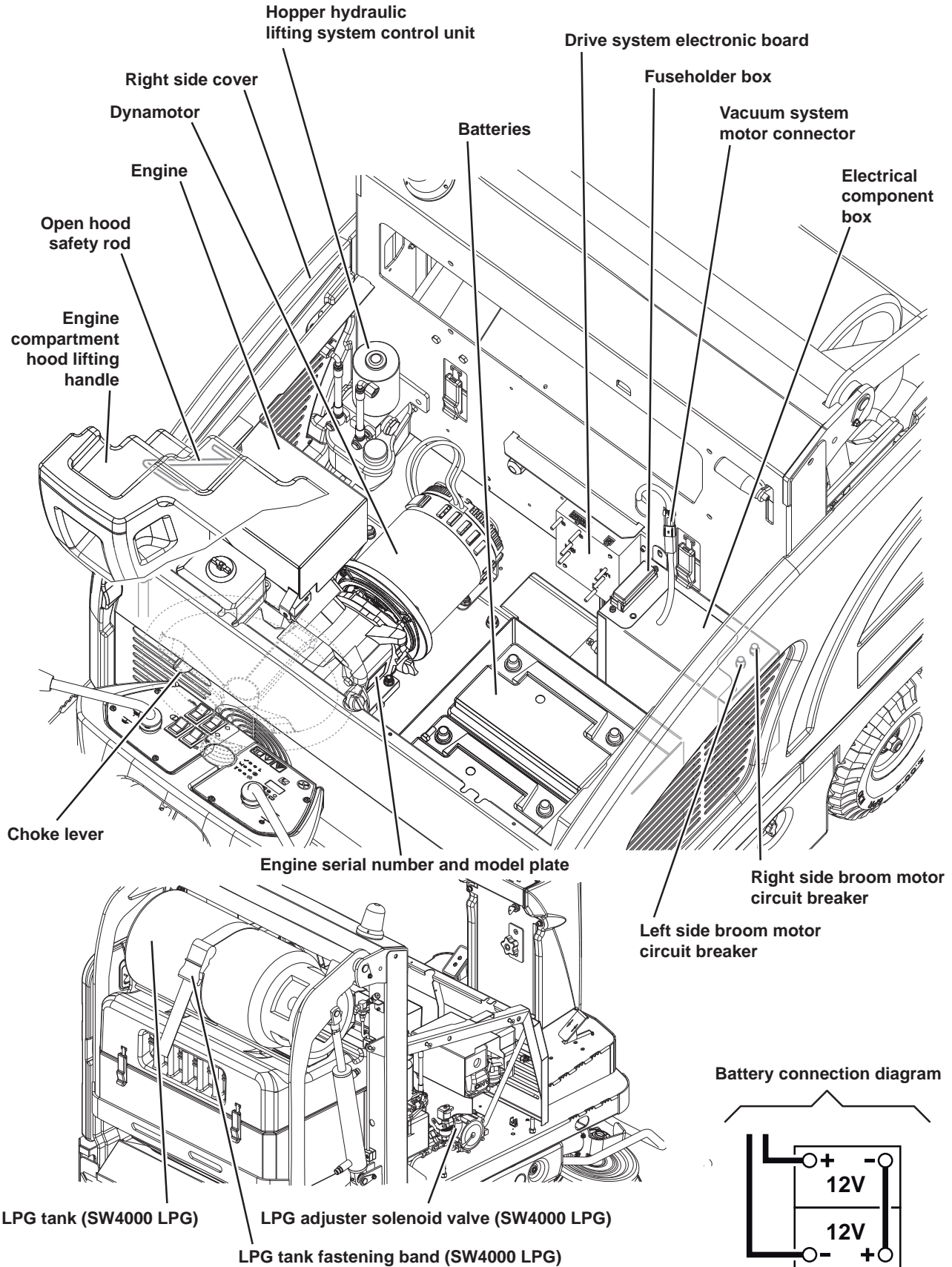

Control Panel (SW4000 Petrol/LPG)

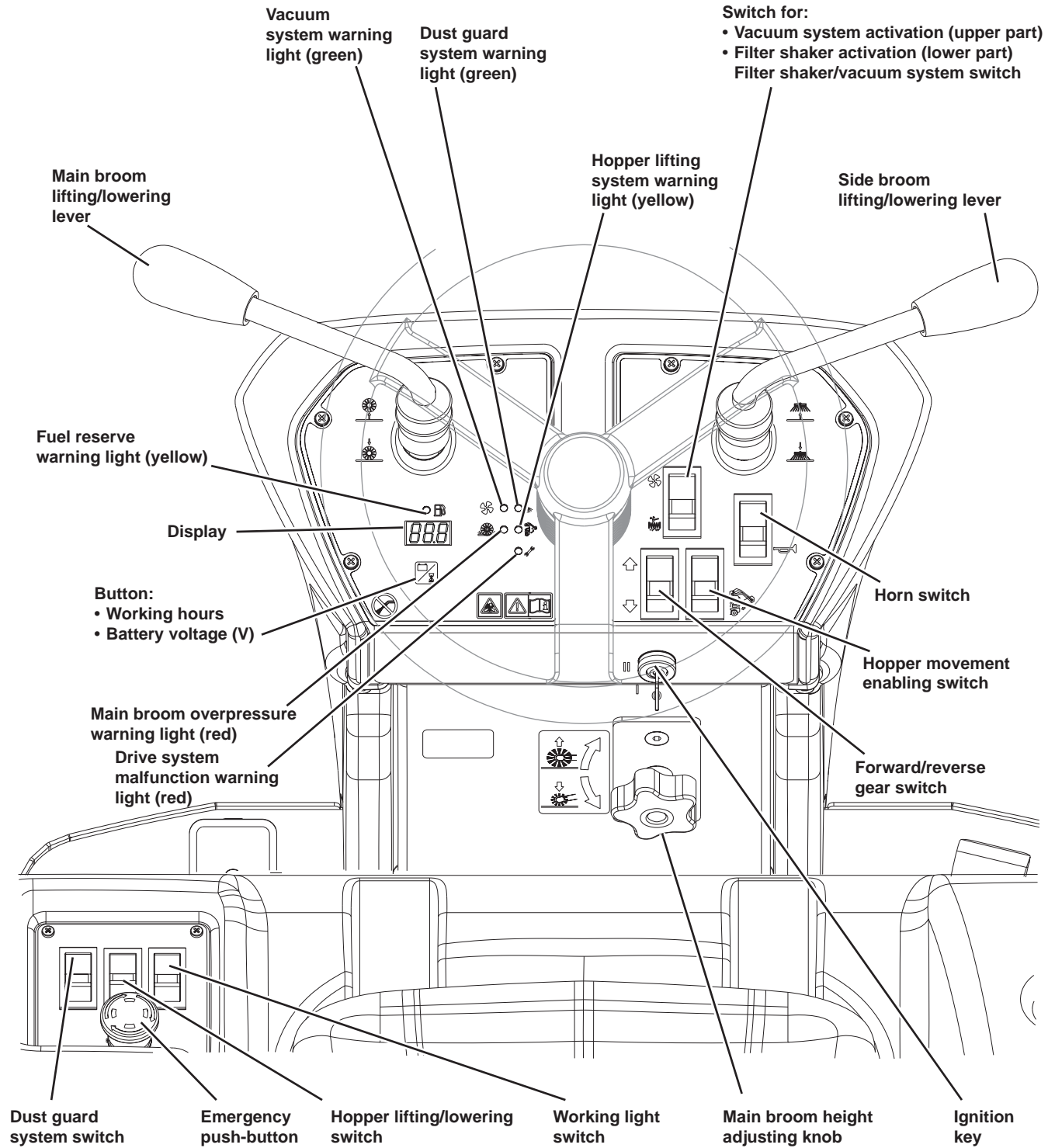

Service and Diagnostic Equipment

Besides a complete set of standard meters, the following instruments are necessary to perform fast checks and repairs on Nilfisk-Advance machines:

Laptop computer charged with the current version of EzParts, Adobe Reader and (if possible) Internet connection

- Digital Volt Meter (DVM)
- Amp clamp with possibility of making DC measurements
- Hydrometer
- Battery charge tester to check 12V batteries
- Static control wrist strap
- Dynamometric wrench set
- A copy of the User Manual and Spare Parts List of the machine to be serviced (provided with the machine or available at www.advance-us.com or other Nilfisk-Advance websites).

The following equipment is also available at Nilfisk-Advance Centers:

- Italsea universal programmer, P/N 9097297000



Technical Data

Model		SW4000 B	SW4000 P	SW4000 LP
Cleaning width	with one side broom	38.3 in (975 mm)		
	with two side brooms	49.2 in (1,250 mm)		
Main broom size (length x diameter)		27.6 x 13.4 in (700 x 340 mm)		
Side broom diameter		17.7 in (450 mm)		
Theoretical working capacity	main broom	52,743 ft ² /h (4,900 m ² /h)		
	with two side brooms	73,463 ft ² /h (6,825 m ² /h)		
	with two side brooms	94,184 ft ² /h (8,750 m ² /h)		
Hopper	capacity	19.8 US gal (75 liters)		
	maximum liftable weight	220 lb (100 kg)		
	maximum lifting height	62.6 in (1,590 mm)		
Filter	cleaning system	Electrical filter shaker		
	area	75 ft ² (7 m ²)		
	filtering capacity	4 µm		
Power source		24 Volt batteries	-	
Power		-	4,1 kW (5,5 CV) @ 3.600 giri/min	
Engine model (*)		-	Honda GX-200	
Tank capacity		-	2 US gal (7,8 litres)	-
LPG Tank capacity		-	-	33 lb (15 Kg)
Main broom	motor power	0.8 hp (600 W)		
	speed	550 rpm		
Side broom	motor power	0.12 hp (90 W)		
	speed	110 rpm		
Vacuum	motor power	0.35 hp (260 W)		
Drive	type	Electric drive on front wheel		
	gearmotor power	1.35 hp (1,000 W)		
	forward speed	4.3 mi/h (7 km/h)		
	reverse speed	2.8 mi/h (4.5 km/h)		
Maximum gradient when working		20 %		
Hopper hydraulic control unit		0.33 hp (250 W)		
Filter shaker motor		0.12 hp (90 W)		
Total absorbed power		2.7 hp (2.0 kW)		
Working autonomy		4,5 h	13 h	25 h
Dimensions (length x width x height)	machine body	64.5 x 40.7 x 52.3 in (1,640 x 1,035 x 1,330 mm)		
	machine with side brooms	64.5 x 41.3 x 52.3 in (1,640 x 1,050 x 1,330 mm)		
	machine with flashing light	64.5 x 41.3 x 57.7 in (1,640 x 1,035 x 1,390 mm)		
	machine with FOPS protective roof (optional)	64.5 x 40.7 x 78.3 in (1,640 x 1,035 x 1,990 mm)		
	battery compartment	14.5 x 32 x 15.3 in (370x812x390 mm)	14.2 x 15 x 8.7 in (360 x 380 x 220 mm)	
LPG tank maximum size (length x diameter)		-	-	28.3 x 11.8 in (720 x 300 mm)

Technical Data (Continues)

Model		SW4000 B	SW4000 P	SW4000 LP
Weight	kerb weight without batteries	954 lb (433 Kg)	-	-
	kerb weight	-	1,126 lb (511 Kg)	1,135 lb (515 Kg)
	total kerb weight (*)	1,816 lb (824 Kg)	1,309 lb (594 Kg)	1,371 lb (622 Kg)
	front axle kerb weight (*)	696 lb (316 Kg)	553 lb (251 Kg)	560 lb (254 Kg)
	rear axle kerb weight (*)	1,120 lb (508 Kg)	756 lb (343 Kg)	811 lb (368 Kg)
	gross vehicle weight (GVW)	2,215 lb (1,005 Kg)	1,708 lb (775 Kg)	1,770 lb (803 Kg)
Wheel specific pressure on the floor (front - rear wheels, in running conditions) (**)		130 - 58 lbf/in ² (0.9 - 0.4 N/mm ²)	116 - 29 lbf/in ² (0.8 - 0.2 N/mm ²)	
Sound pressure level at workstation (ISO 11201, ISO 4871, EN 60335-2-72) (LpA)		65 ±3 dB(A)	75 ±3 dB(A)	
Machine sound pressure level (ISO 3744, ISO 4871, EN 60335-2-72) (LwA)		86 dB(A)	94 dB(A)	
IP protection class		X3		
Dust guard system water tank (optional) capacity		5.3 US gal (20 liters)		
U-turn space (right - left)		75.6 - 74.4 in (1,920 - 1,890 mm)		
Vibration level at the operator's arms (ISO 5349-1)		< 98 in/s ² (< 2.5 m/s ²)		
Vibration level at the operator's body (ISO 2631-1)		< 19.6 in/s ² (< 0.5 m/s ²)	< 35.4 in/s ² (< 0.9 m/s ²)	

(*) With operator on board, without batteries and with hopper empty.

(**) Machines have been tested under the following conditions:

- With operator on board (165.3 lb - 75 kg)
- Battery of maximum size
- Brooms of maximum size
- Full Tanks
- Optional components installed
- Weight on wheels checked
- Print on the floor checked on cement for each single wheel

Result expressed as maximum value for both front and rear wheels

Machine material composition and recyclability				
Type	Recyclable percentage	SW4000 B weight percentage	SW4000 P weight percentage	SW4000 LP weight percentage
Aluminium	100 %	0.0 %	0,0 %	0,0 %
Electric motors - various	29 %	10.8 %	21,1 %	21,1 %
Ferrous materials	100 %	53.5 %	48,3 %	48,8 %
Wiring harnesses	80 %	1.2 %	0,8 %	0,8 %
Liquids	100 %	0.4 %	0,5 %	0,5 %
Plastic - non-recyclable material	0 %	1.0 %	0,9 %	0,8 %
Plastic - recyclable material	100 %	9.8 %	8,6 %	8,4 %
Polyethylene	92 %	7.0 %	6,0 %	5,9 %
Rubber	20 %	4.1 %	3,5 %	3,5 %
Cardboard - paper - wood	100 %	12.2 %	10,3 %	10,2 %

Technical Data (Continues)



Caution! *If the machine is to be used at ambient temperatures below +10°C, the oil should be changed with equivalent oil having a viscosity of 32 cSt. For temperatures below 0°C, use an oil with lower viscosity.*

Hydraulic oil technical data			
AGIP ARNICA		46	32
Viscosity at 104 °F (40 °C)	in ² /s (mm ² /s)	0.07 (45)	0.05 (32)
Viscosity at 212 °F (100 °C)	in ² /s (mm ² /s)	0.012 (7.97)	0.009 (6.40)
Viscosity index	/	150	157
Flash point COC	°F (°C)	419 (215)	396 (202)
Pour point	°F (°C)	-32.8 (-36)	-32.8 (-36)
Density at 15 °C (59 °F)	lb/gal (kg/l)	1.9 (0.87)	1.9 (0.865)

Dimensions

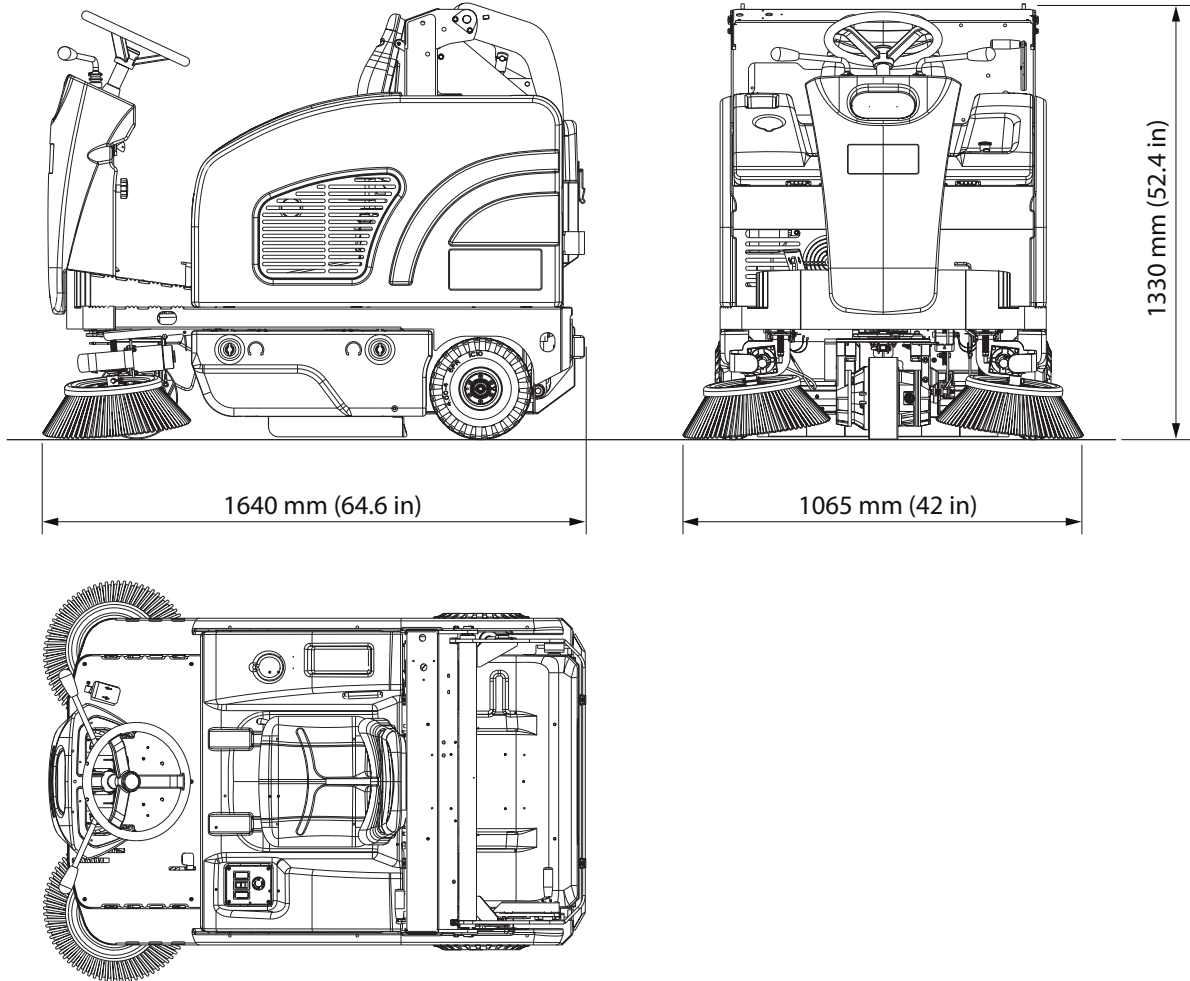

P200092

Maintenance

The lifespan of the machine and its maximum operating safety are ensured by correct and regular maintenance.



Warning! Read carefully the instructions in the Safety chapter before performing any maintenance procedure.

The following tables provides the scheduled maintenance. The intervals shown may vary according to particular working conditions, which are to be defined by the person in charge of the maintenance.

For instructions on maintenance procedures, see the following paragraphs.

Scheduled Maintenance Table (SW4000 Battery)

Procedure	Upon delivery	Every 10 hours	Every 50 hours	Every 100 hours	Every 200 hours	Every year
Battery charging	(1)					
Battery (WET) fluid level check		(2)				
Side and main broom height check						
Service brake cable adjustment		(3)				
Hopper dust filter check and cleaning ("A" method)			(4)			
Hopper hydraulic lifting system oil level check			(2)			
Skirt height and operation check						
Dust guard system water filter check and cleaning						
Hopper dust filter check and cleaning ("B" method)				(4)		
Filter shaker operation check						
Main broom driving belt check						
Brake adjustment						
Nut and screw tightening check				(5)		
Steering chain cleaning						
Safety system operation check				(2)		
Brake pad check/adjustment/replacement				(3)		
Hopper dust filter check and cleaning ("C" method)					(4)	
Main broom driving belt replacement						
Hopper gasket integrity check						
Lifted hopper sensor operation check/adjustment						
Motor carbon brush check and replacement						
Hydraulic system oil change						(6)

- (1) Daily or after using the machine.
- (2) Or before start-up.
- (3) Or more frequently if the machine is used on slopes.
- (4) Or more often in dusty areas.
- (5) And after the first 8 running-in hours.
- (6) Change the hydraulic system oil for the first time after 500 hours, then every 2,000 hours or every year.

Scheduled Maintenance Table (SW4000 Petrol/LPG)

Procedure	Upon delivery	Every 10 hours	Every 50 hours	Every 100 hours	Every 200 hours	Every year
Engine oil level check	(1)					
Battery fluid level check		(2)				
Side and main broom height check						
Engine air filter check		(1)				
Service brake cable adjustment		(3)				
Hopper dust filter check and cleaning ("A" method)			(4)			
Hopper hydraulic lifting system oil level check			(2)			
Skirt height and operation check						
Dust guard system water filter check and cleaning						
Engine air filter cleaning			(4)	(4)		
Hopper dust filter check and cleaning ("B" method)				(4)		
Filter shaker operation check						
Main broom driving belt visual inspection						
Brake replacement						
Engine oil change				(5) (6)		
Spark plug check/cleaning						
Nut and screw tightening check				(6)		
Steering chain cleaning				(*)		
Safety system operation check				(2)		
Engine filter trap cleaning						
Engine baffle plate cleaning						
Fuel filter cleaning				(7)		
Brake pad check/adjustment/replacement				(3)		
Hopper dust filter check and cleaning ("C" method)					(4)	
Main broom driving belt replacement						
Hopper gasket integrity check						
Lifted hopper sensor operation check/adjustment						
Fuel valve filter cleaning (Petrol)						
Engine paper air filter replacement						
Spark plug replacement						
Engine idle speed check/adjustment						
Valve clearance check/adjustment						(7)
Hydraulic system oil change						(8)
Supply hose replacement (LPG)						
Engine combustion chamber check						Every 500 hours (7)
Fuel hose check/replacement (Petrol)						Every 2 years (7)

- (1) Daily or after using the machine.
- (2) Or before start-up.
- (3) Or more frequently if the machine is used on slopes.
- (4) Or more often in dusty areas.
- (5) Or every 6 months.
- (6) And after the first 20 running-in hours.
- (7) Maintenance procedures to be performed by an authorised Honda dealer.
- (8) Change the hydraulic system oil for the first time after 500 hours, then every 2,000 hours or every year.

Chassis System

Chassis (main parts)

1. Front side supporting the steering assembly and side brooms.
2. Center side supporting batteries/engine with dynamotor and main broom.
3. Rear side supporting the hopper and rear wheels on hubs.
4. Central holder for separating wall between engine compartment/vacuum system compartment, and for supporting the hopper lifting linkages.

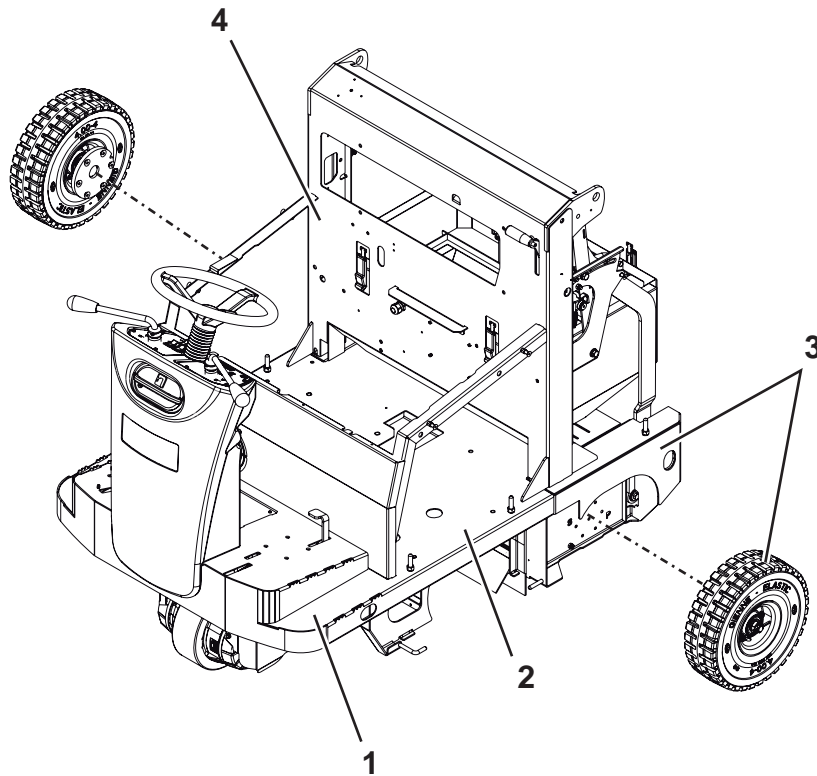

P200093

Control System

Functional Description

The machine is started by the ignition key (SW1), located on the steering column.

The key starts the machine when turned to II, thus powering the relay (K4). The relay (K4) stays on even when the key returns to I. All the accessories (except the buzzer) are on only when the relay (K4) is on too.

Ahead of the ignition key (SW1) there is the emergency push-button (SW0). The key circuit is protected by the relevant fuse (F4).

The machine different functions are mainly controlled by the switches located on the main dashboard (on the steering column) and on the secondary dashboard (beside the driver's seat) and by the 2 broom levers.

For functions not requiring an electronic management, the switches operate directly or by means of relays, on the relevant drives. For functions requiring timers or electronic controls, the commands generated when operating the switches are read by the dashboard electronic board (EB2) which drives the outputs directly or by means of external relays.

The electric drive system control is made by the forward/reverse gear switch (SW2) and the gear pedal (R1) which provide signals to the drive system electronic board (EB1).

For all the details concerning the described functions, see the relevant chapters.

Dashboard Electronic Board Specifications

The dashboard electronic board performs the following:

- a. **HOOR COUNTER:** By default, the 3-digit display (A) shows the number of hours stored in the hour counter. The hour counter proceeds with counting, only when the main broom turns. When the hour counter reaches 999, the next numbers are shown by the 3 more meaningful digits by adding a (low) dot for separating thousands (i.e.: 1234 will be shown as 1.23).
- b. **BATTERY VOLTAGE DISPLAY:** by pressing the push-button (B) (with the machine running) the display will switch from the 3-digit hour counter (A) to the battery voltage. The display will automatically return to the hour counter 5" after the last pressing of the push-button (B).
- c. **MAIN BROOM MOTOR PROTECTION:** By reading the voltage drop on main broom fuse (FA), the main broom motor amperage (M4) is monitored. If the voltage drop is higher than 40mV, the warning light (C) starts flashing. If this condition persists, after a time inversely proportional to the value of voltage drop detected, the broom motor is stopped (the warning light continues to flash). To reset, turn the ignition key on and off (SW1).

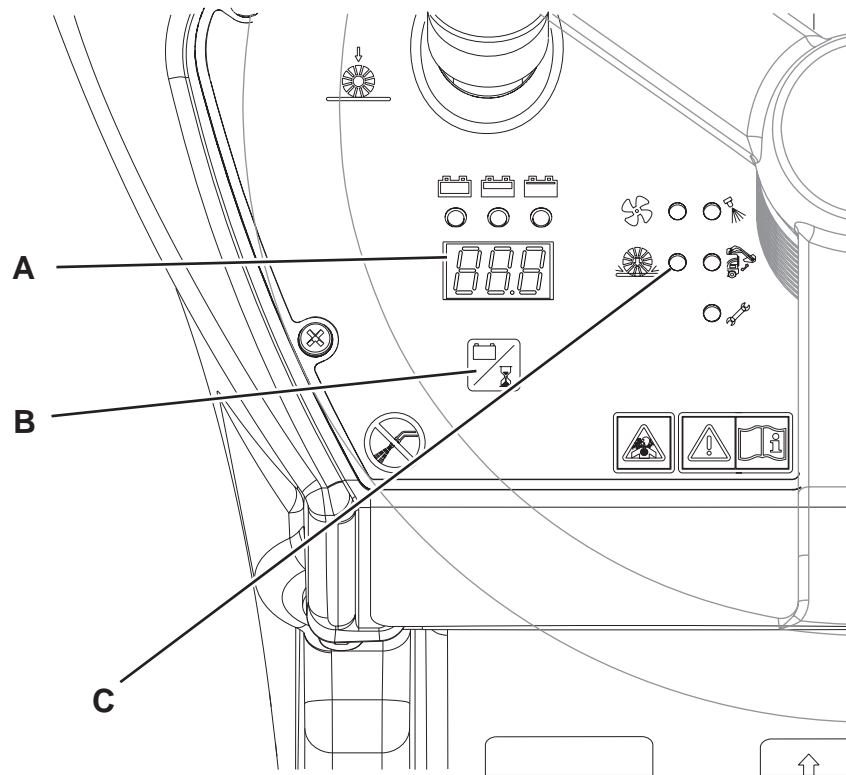

d. **BATTERY PROTECTION:** Battery charge status is shown by the 3 LEDs depending on the type of battery (WET/GEL) according to the following diagram:

		WET	GEL
1	Green LED on (fixed)	V>22.0	V>22.2
2	Yellow LED on (fixed)	22.0>V>20.4	22.2>V>21.6
3	Red LED flashing	V>20.4	V>21.6

When the red LED starts flashing, broom function is automatically deactivated.

e. **BATTERY TYPE DISPLAY (WET/GEL):** Each time the machine is turned on with the ignition key, the 3 battery charge LED indicators show the battery type as follows:

Battery Type	Flashing pattern
WET	4 flashes of the RED warning light
GEL	4 flashes of the GREEN warning light

f. **PROCEDURE FOR BATTERY SETTING (WET/GEL):** Hold the push-button (B) down while you turn the key on and hold it for 5 sec. The 3 LEDs will then show again the current setting with the continuous flashing of the corresponding LED (see the previous step), while further pressing the push-button (B) will change the current setting. The last setting will be stored when (B) is not pressed for more than 5 sec.

g. **TIMED FUNCTION ACTIVATION:** BROOM, VACUUM and FILTER SHAKER are turned on and off by pressing the relevant controls and according to the conditions of the relevant sensors as shown in their respective chapters

OTHER INDICATIONS WITH DEDICATED WARNING LIGHTS: fuel reserve warning light (D), vacuum system warning light (E), dust guard system warning light (F), hopper lifting warning light (G), main broom overpressure warning light (C), drive system diagnostic warning light (I).

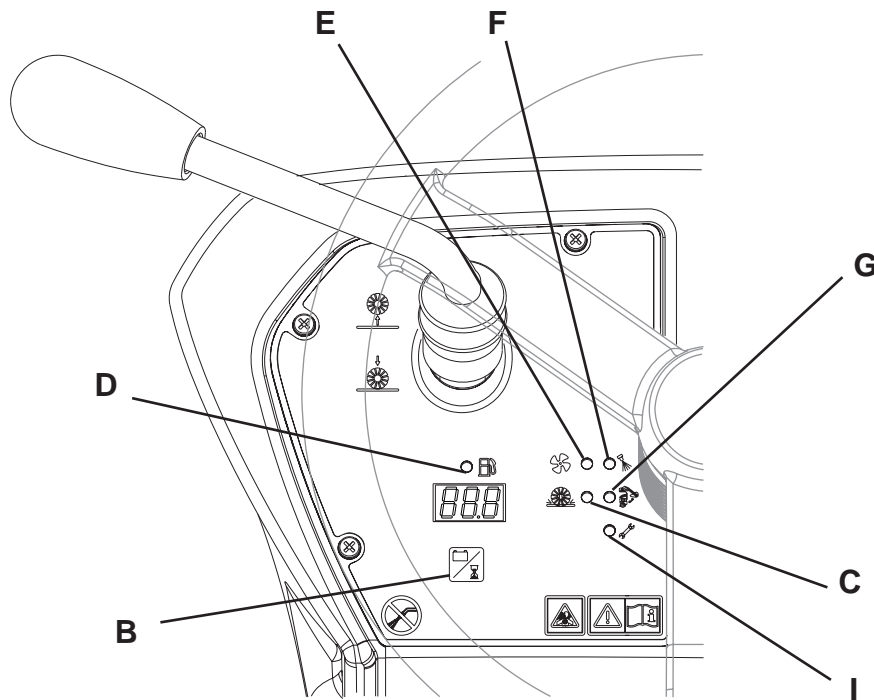

Wiring Diagram (SW4000 Battery)

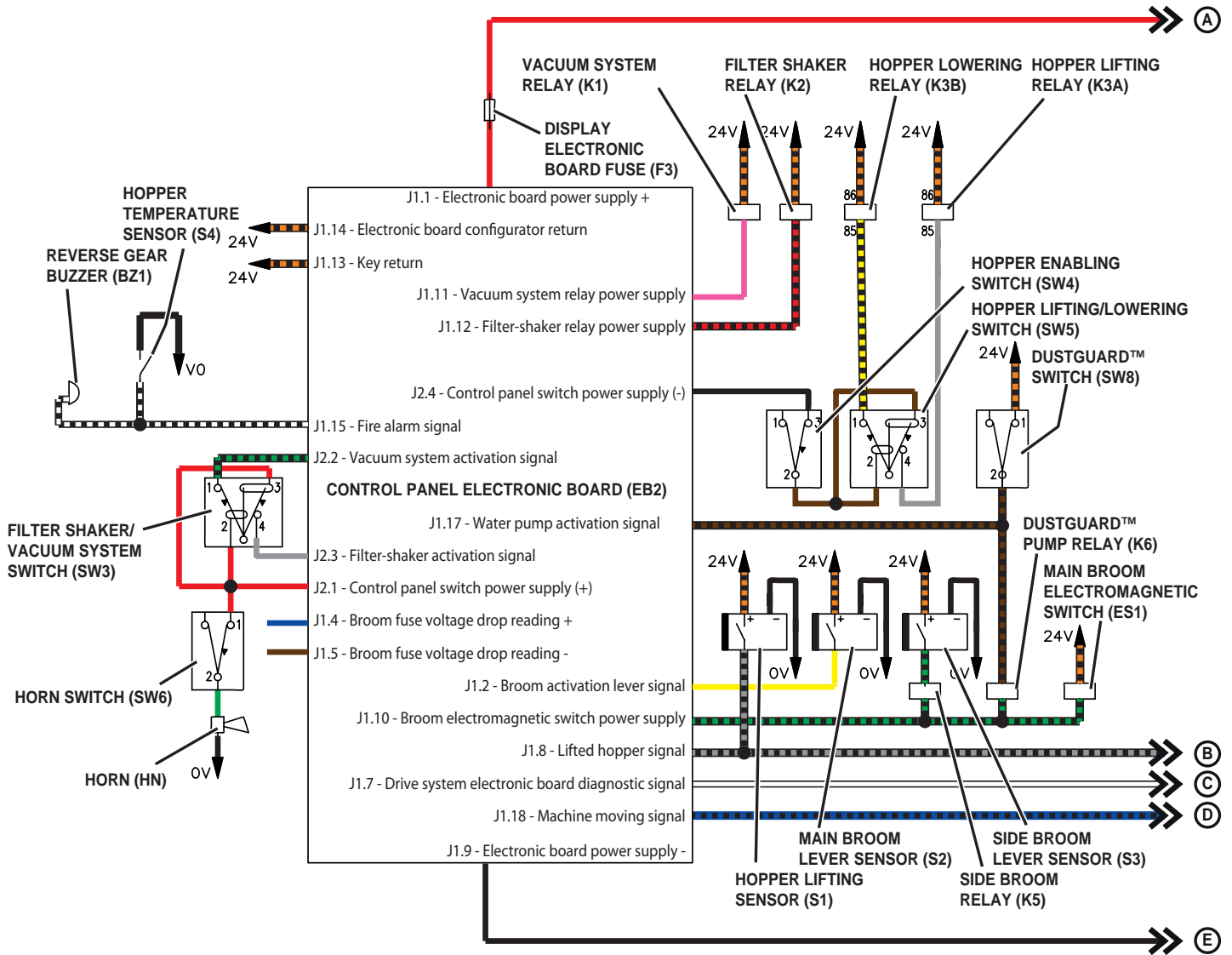
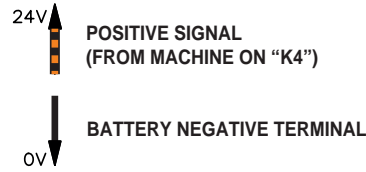

Wiring Diagram (SW4000 Battery)

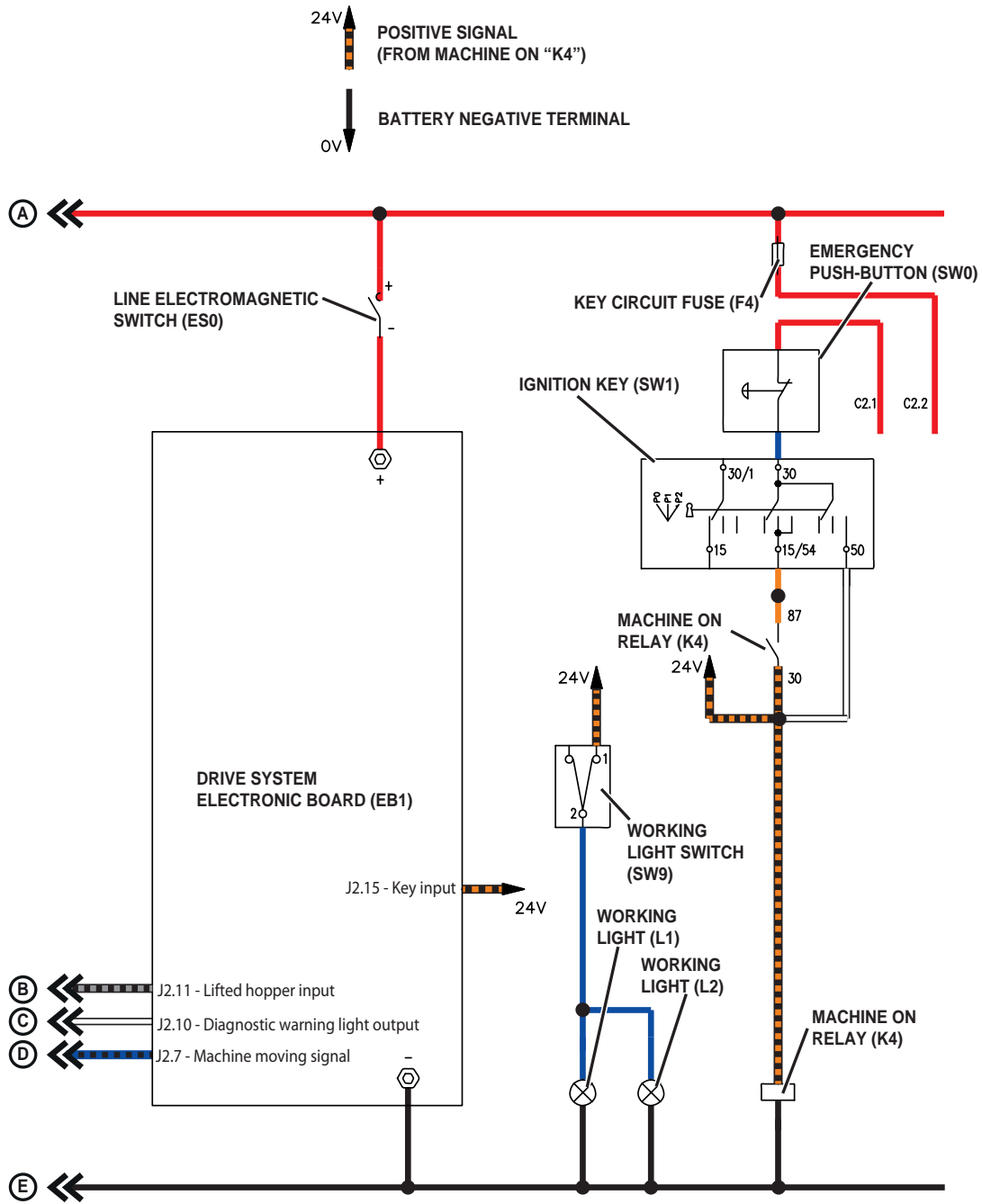

Wiring Diagram (SW4000 Petrol/LPG)

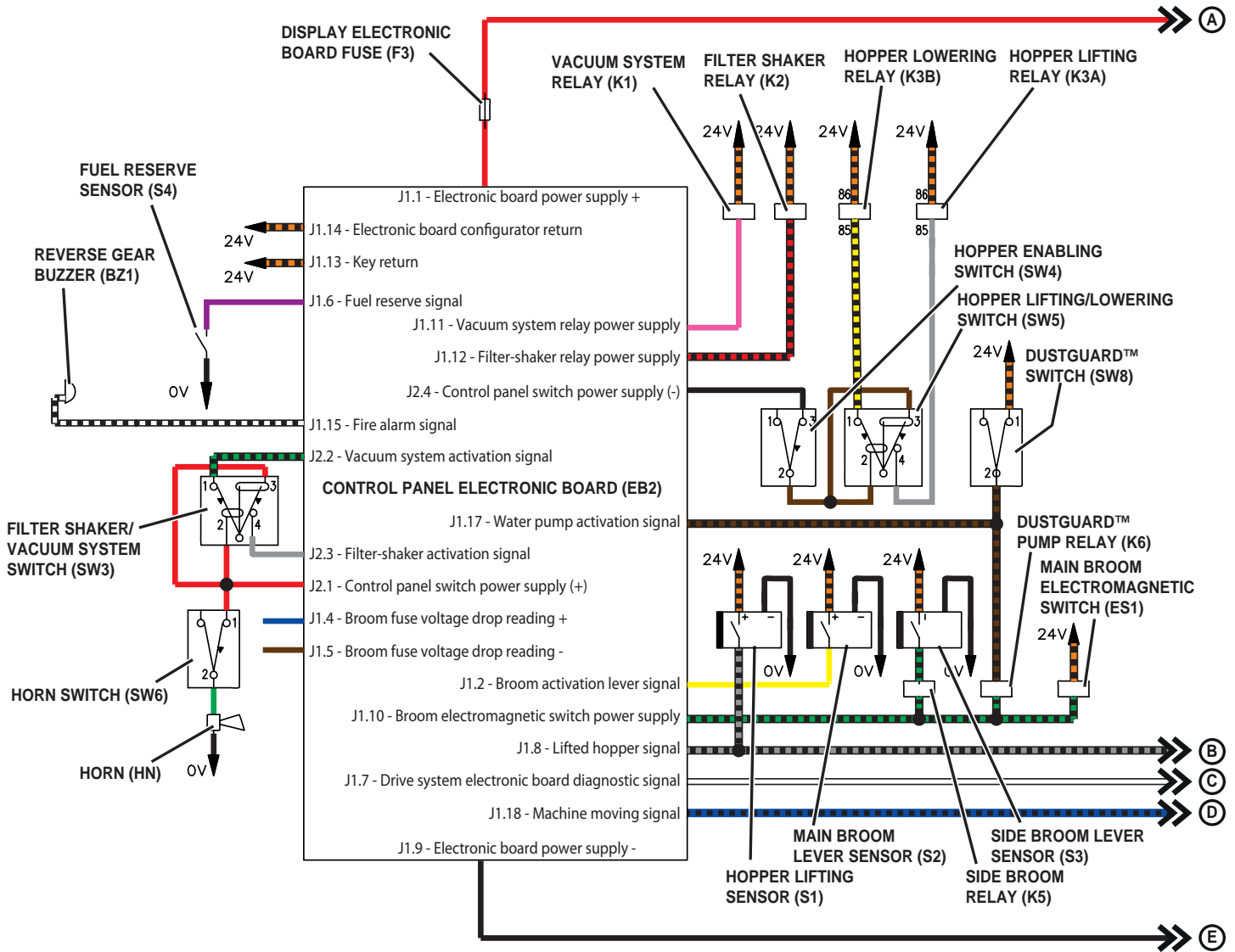
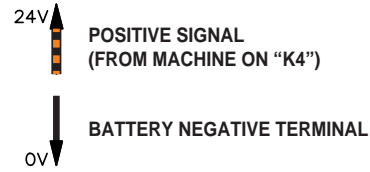

Wiring Diagram (SW4000 Petrol/LPG)

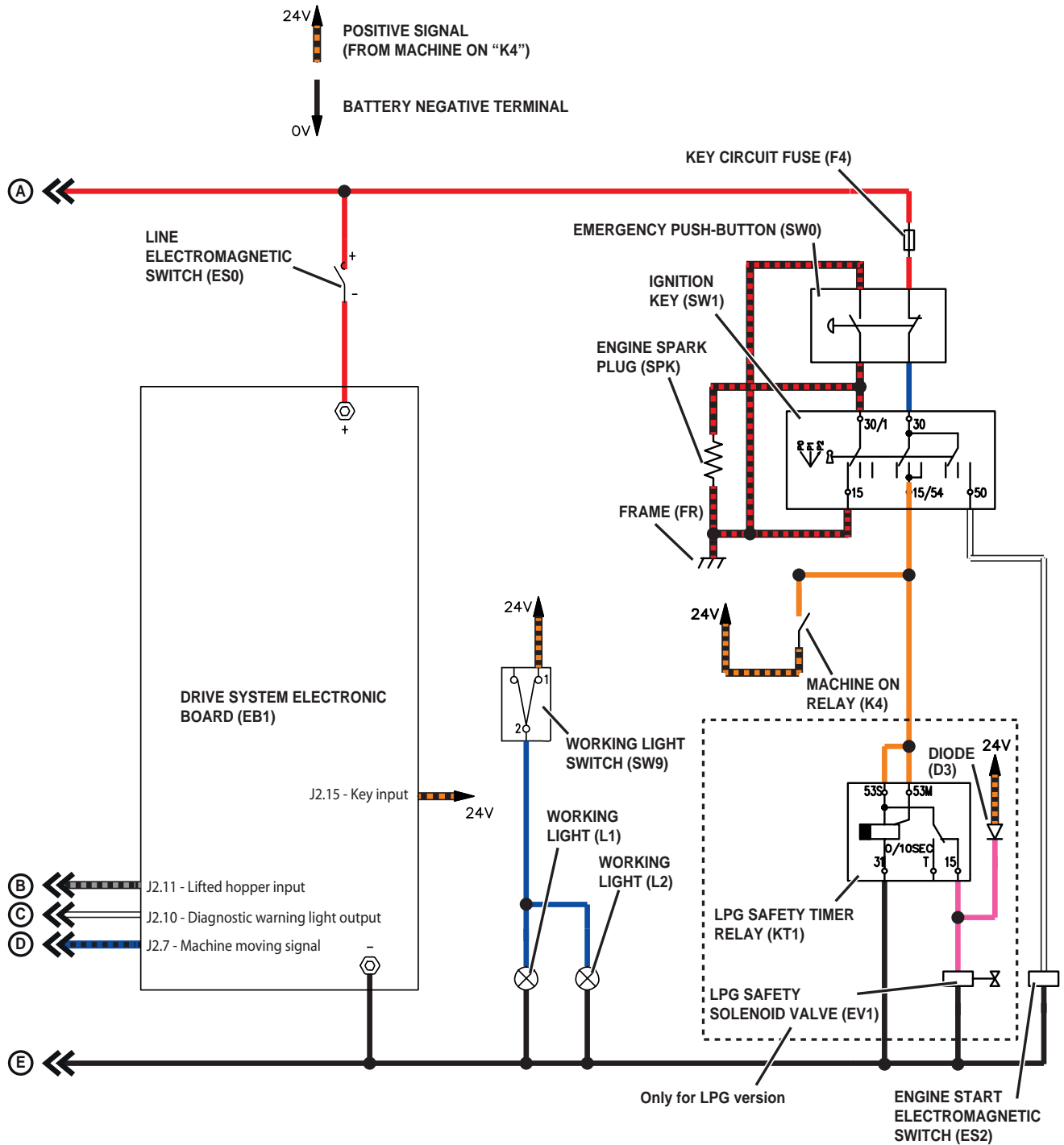

Component Locations

- Dashboard
- Dashboard electronic board (EB2)
- Ignition key (SW1)



Troubleshooting

Trouble	Possible Cause	Remedy
(For SW4000 Battery) When turning the ignition key to "II", the display does not turn on and the machine does not operate.	The battery connector is disconnected.	Connect the battery connector.
	The fuse (F3) and/or (F0) is open.	Check/replace the fuses.
	The emergency push-button has been pressed.	Check and release the emergency push-button.
(For SW4000 Petrol/LPG) "L O U" (A) (Low Voltage) display indication	Battery voltage lower than 24.0 V.	Decrease the main broom pressure on the floor.
		"L O U" (A) (Low Voltage) display indication
		If the problem persists, it may be necessary to calibrate the engine rpm (see Petrol Engine – LPG Engine chapter).
(For SW4000 Petrol/LPG) "H I U" (A) (High Voltage) flashing display indication	Battery voltage higher than 32.4V.	Turn off the engine each time the machine is stopped.
		If the problem persists, it may be necessary to calibrate the engine rpm (see Petrol Engine chapter).

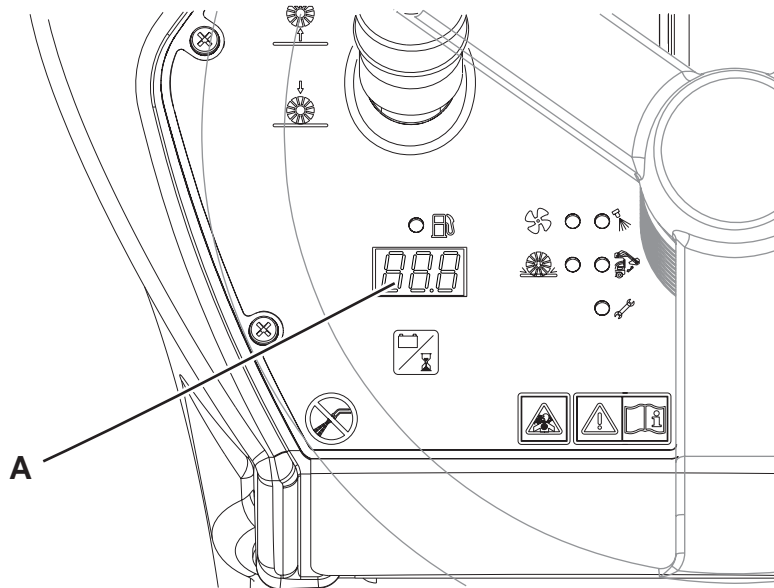

Dashboard Electronic Error Codes

The drive system warning light (A) on the dashboard electronic board (EB2) shows the error codes of the drive system electronic board (EB1). For the details, see the Wheel System, Drive chapter.

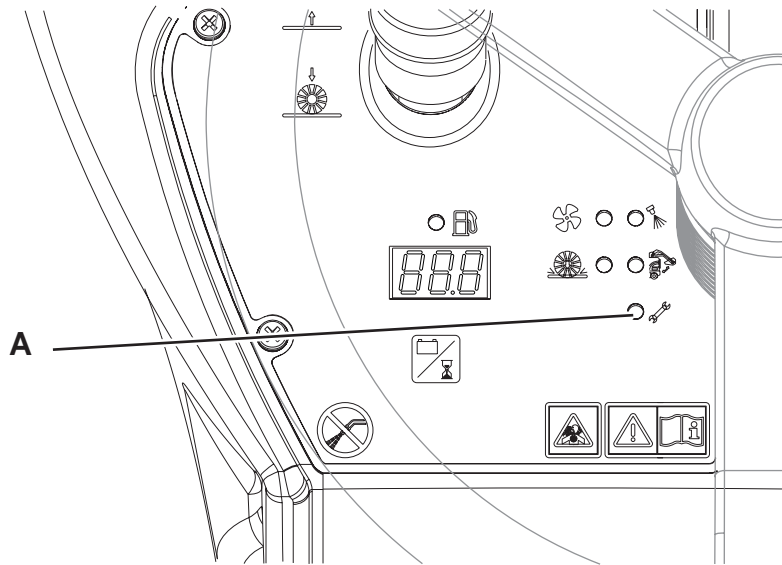

Connectors on the dashboard electronic board

J1: MOLEX MINIFIT type, 18-ways vertical (A)

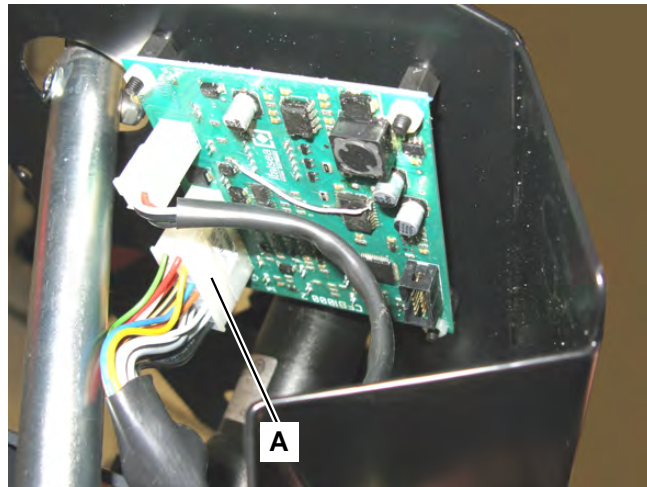
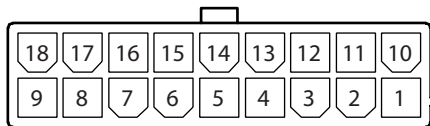

P200221

PIN	Description	Electronic board in/out	V ref.	I max.	Connected to
1	Electronic board power supply +	in	24V	3A	F10
2	Broom activation lever signal	in	24V (when the description is ON)	<1A	S2
3	Engine on signal	in	24V (when the description is ON)	<1A	K4.30
4*	Broom fuse voltage drop reading +	in	0V (when the description is OFF)	<1A	FA+
5*	Broom fuse voltage drop reading -	in	0V (when the description is OFF)	<1A	FA-
6	Fuel reserve signal	in	0V (when the description is OFF)	<1A	S5
7	Drive system electronic board diagnostic signal	in	(24V)	<1A	EB1.J2.10
8	Lifted hopper signal	in	24V (when the description is ON)	<1A	S1
9	Electronic board power supply -	in	0V (when the description is OFF)	3A	-B
10	Broom electromagnetic switch power supply	out	0V (when the description is OFF)	1A	ES1, K5
11	Vacuum system relay power supply	out	0V (when the description is OFF)	1A	K1.85
12	Filter shaker relay power supply	out	0V (when the description is OFF)	1A	K2.85
13	Return from key	in	24V (when the description is ON)	<1A	K4.30/SW1
14**	Electronic board configurator return (Battery)	in	24V (when the description is ON)	<1A	K4.30
15	Fire alarm signal	in	0V (when the description is OFF)	<1A	S4
16	Hopper lifting control	out	0V (when the description is OFF)	1A	K3A.85
17	Water pump activation signal	in	24V (when the description is ON)	<1A	SW8.2
18	Machine moving signal	in	0V (when the description is OFF)	<1A	EB1.7

J1: MOLEX MINIFIT type, 18-ways vertical (A) (continues)

Further notes about dashboard electronic board (PIN - J1.14)

The dashboard electronic board (EB2) recognises if it has been assembled on a Battery or Petrol/LPG machine version depending on the PIN J1.14 status:

- PIN J1.14 - connected to +24V = Battery version,
- PIN J1.14 - NOT connected = Petrol/LPG version .

Battery version (PIN - J1.14 at +24V)

SAFETY BATTERY FUNCTION: The battery loading status is displayed by means of 3 LEDs (A) Green, (B) Yellow, (C) Red, up to the battery type installed (WET/GEL) as shown below:

Threshold values		Threshold values of change status (V, toll.±0,1)	
		WET	GEL
1	LED (A) Green fixed <=> LED (B) Yellow fixed	22,0	22,2
2	LED (B) Yellow fixed <=> LED (C) Red flashing 1Hz	20,4	21,6

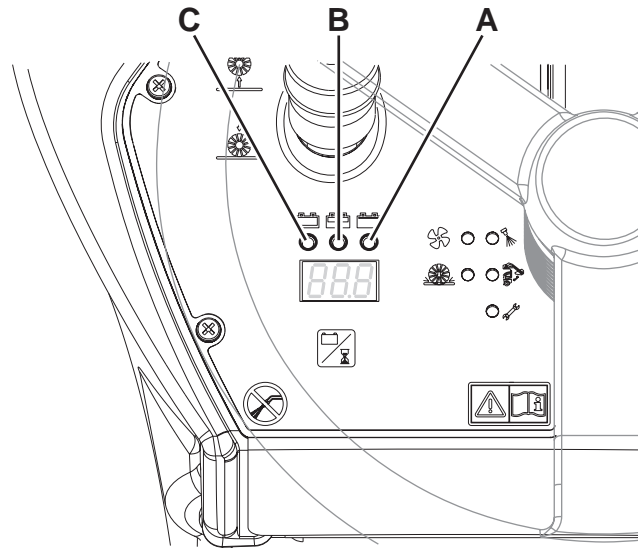

P200247b

The change status is filtered with a 3 sec. delay as regards to the battery tension reading. When threshold value 2 is reached, the J1.10 output is automatically shutted off with 5 sec. delay. Without any regards to the battery tension reading value the change values status 2 is fixed. The only way to reset the status is the machine switching off by using the ignition key (SW1).

J1: MOLEX MINIFIT type, 18-ways vertical (A) (continues)

Petrol/LPG version (PIN - J1.14 not connected)

The RPM value of the Petrol/LPG engine is fixed to 2.750 rpm ± 50 rpm

The fixed RPM value of the Petrol/LPG engine should be in any case as follows

- with the loaded batteries, engine On, all functions Off => the battery tension is between 27,0V and 31,0V
- with the loaded batteries, engine On, all functions On => the battery tension is higher than 24,0V

The dashboard electronic board (EB2) displays 2 alarms, shown by the display (A) and the LED (B) flashed, if are not matched for more than 5 consecutive minutes the following conditions:

Shown on display	Battery conditions	Solution	Alternative actions in case the solution does not solve the problem
LOU	V < 24,0V (Low Voltage)	Avoid using the machine for long periods at maximum power or on slopes: leave the engine running with all features turned off for at least ten minutes after each usage.	Recharge the battery with a suitable charger and then adjust the engine RPM (increase the engine RPM till reach again the recommended tension ranges).
HIU	V > 32,4V (High Voltage)	Turn the engine off when you are not working: do not leave the machine for long periods without using any functions.	Adjust the RPM engine (reduce the engine RPM till reach again the recommended tension ranges).

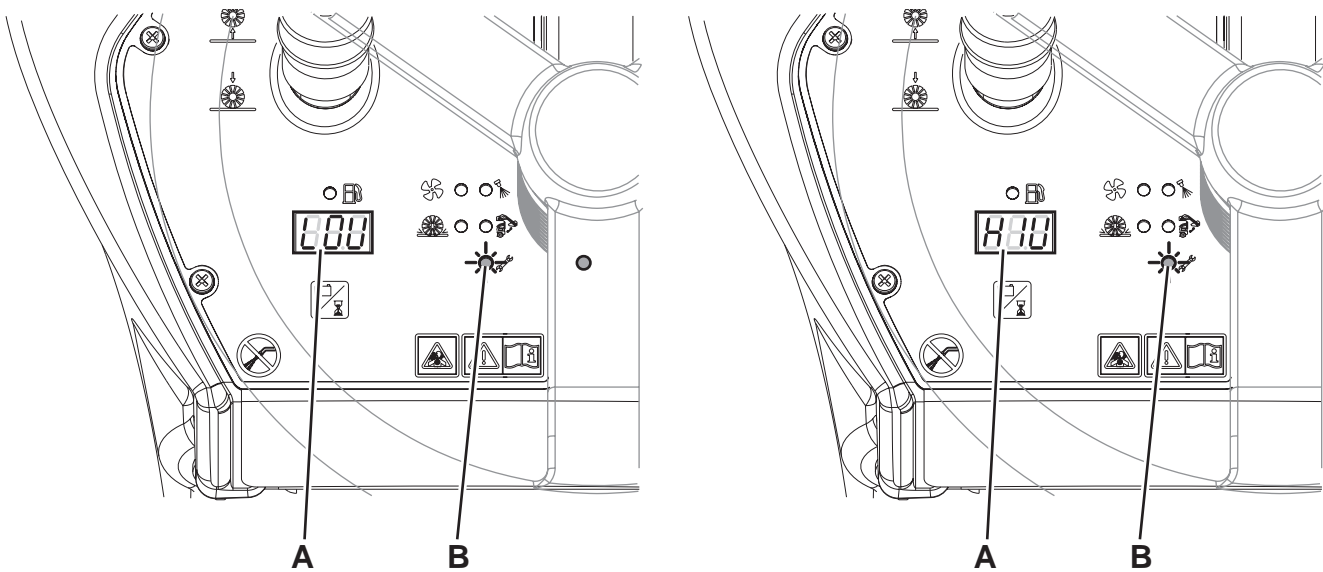

J2: MOLEX MINIFIT type, 4-ways vertical (B)

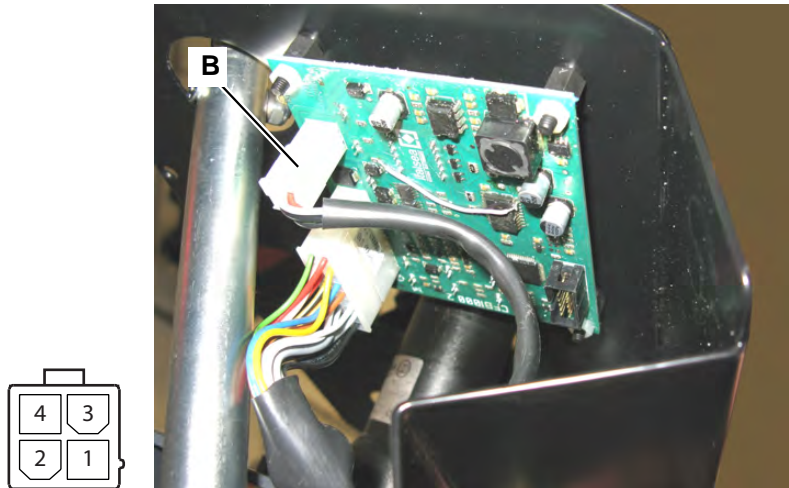

P200098

PIN	Description	Electronic board in/out	V ref.	I max.	Connected to
1	Dashboard switch power supply (+)	out	24V	<1A	SW3, SW8
2	Vacuum system activation signal	in	24V (when the description is ON)	<1A	SW3.1
3	Filter-shaker activation signal	in	24V (when the description is ON)	<1A	SW3.3
4	Dashboard switch power supply (-)	out	0V	<1A	SW4

Removal and Installation

Dashboard Electronic Board Disassembly/Assembly

Disassembly

1. Drive the machine on a level floor.
2. Turn the ignition key to “0” and engage the parking brake.
3. Open the battery/engine compartment hood. Disconnect the battery connector (SW4000 Battery) - Disconnect the batteries (SW4000 Petrol/LPG).
4. Remove the fastening screws (A) of the fairing (B) from the steering column.
5. Slightly lift the steering column (B) by disengaging it from the lower fastener (C).
6. Disconnect the dust guard system quick coupling (D).
7. Retrieve the fairing (B).
8. Under the left side of the control panel, disconnect the connectors (E) of the dashboard electronic board (F).
9. Disengage the four nuts (G) and remove the dashboard electronic board (F).

Assembly

10. Assemble the components in the reverse order of disassembly, and note the following:
 - Set the type of batteries installed on the machine (see Electrical System chapter).

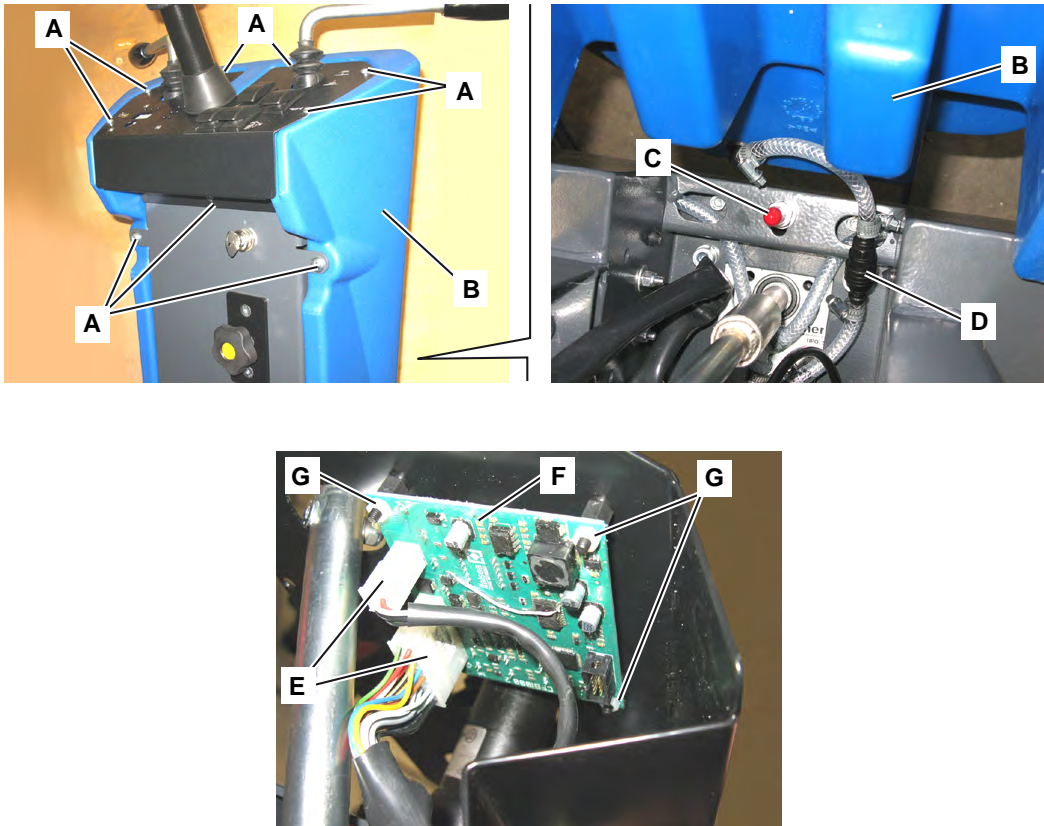

P200101

Dust Control System

Functional Description

The dust raised in the compartment of the main broom, is collected in the rear cargo area by a flow of air generated by the dust control system.

The filter located between the vacuum system and the hopper, retains dirt which is then conveyed through a feedbox into the hopper itself.

The operation of the system depends on the activation of the main broom.

By deactivating the main broom, the dust control system turns off automatically.

There is a vacuum system motor (M1) which is powered by the relay (K1) and protected by the fuse (F1).

The relay (K1) is directly controlled by the dashboard electronic board (EB2) according to the information received by the vacuum system/filter shaker switch (SW3), by the sensor on the broom activation lever (S2), by the machine moving signal received by the drive system electronic board (EB1) and by the lifted hopper sensor (S1).

Normally the vacuum function is turned on when the main broom is lowered with the lever; it can, however, be turned on or off independently with the push-button SW3, it turns off when the machine is stopped, when the hopper is lifted and during activation the electric filter shaker.

There is an electric filter shaker motor (M2) which is powered by the relay (K2) and protected by the fuse (F2). The relay (K2) is directly controlled by the dashboard electronic board (EB2) according to the information received by the vacuum system/filter shaker switch (SW3): When the button is activated for a cycle of 20 seconds during which it is driven 0.5 sec ON and 0.5 sec. OFF for continuously modulating the number of revolutions and the resulting vibration frequencies of the filter.

The vibrating motor shakes the filter allowing dirt trapped in the folds of the same to fall by gravity into the hopper.

This reduces filter maintenance and helps to maintain proper airflow through the filter.

Wiring Diagram

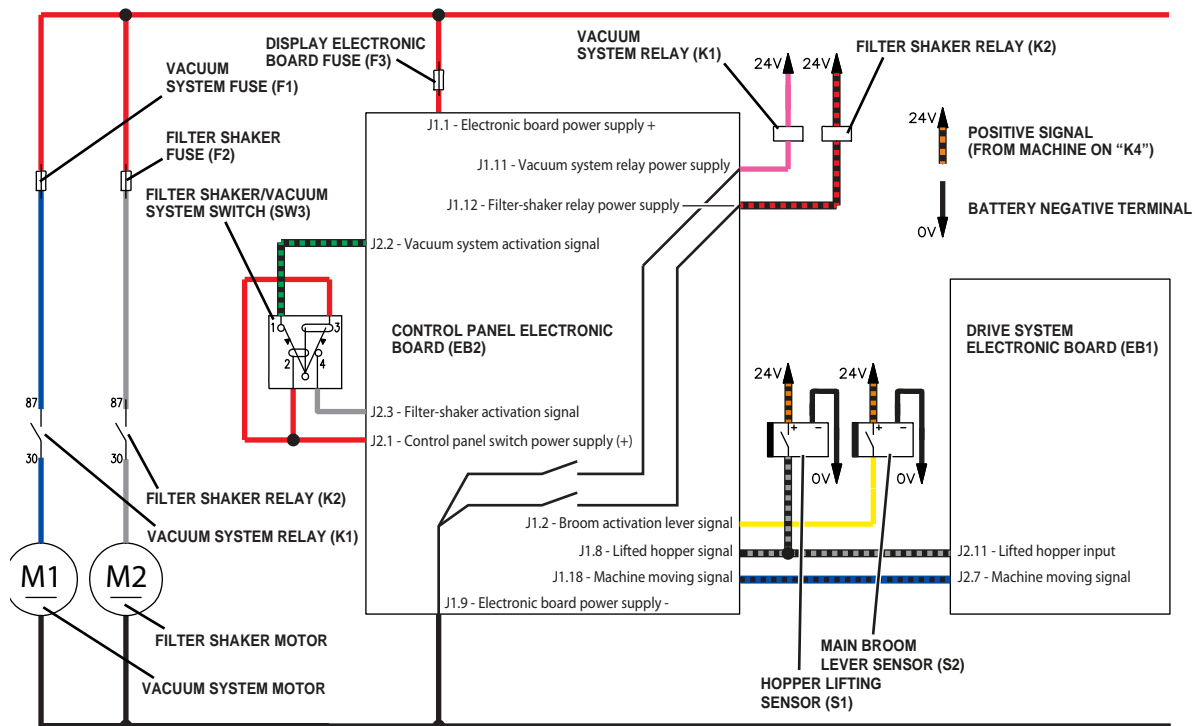

Component Locations

- Filter shaker/vacuum system switch (SW3)
- Vacuum system motor (M1)
- Gasket
- Filter shaker motor (M2)
- Panel filter
- Vacuum system motor fuse (25 A - Battery) (30 A Petrol/LPG) (F1)
- Filter shaker motor fuse (25 A - Battery) (30 A Petrol/LPG) (F2)



Filter shaker/vacuum system switch (SW3)

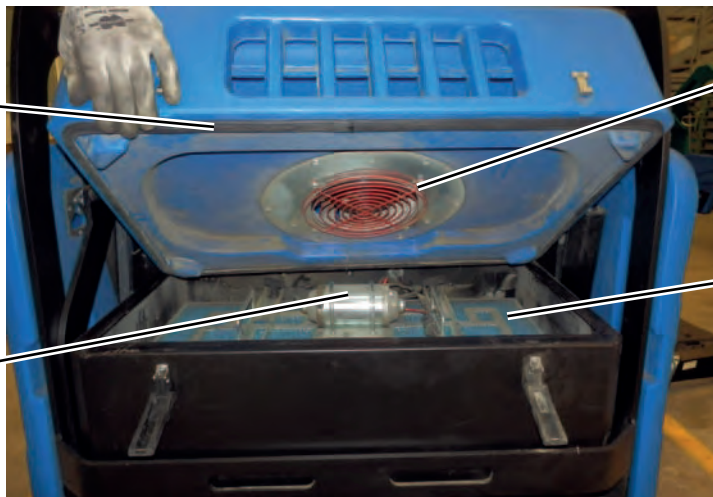

Gasket

Vacuum system motor (M1)

Panel filter

Filter shaker motor (M2)

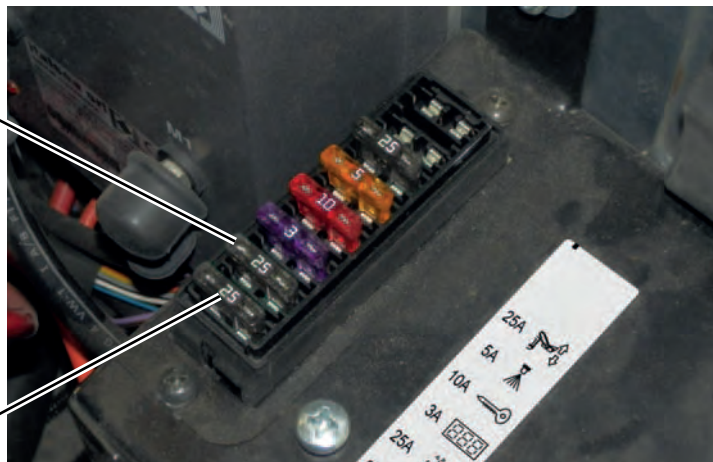

Filter shaker motor fuse (25 A - Battery) (30 A Petrol/LPG) (F2)

Vacuum system motor fuse (25 A - Battery) (30 A Petrol/LPG) (F1)

Maintenance and Adjustments

Panel Dust Filter Cleaning and Integrity Check



Caution! The dust filter must be regularly cleaned to maintain the efficiency of the vacuum system. Follow the recommended filter service intervals for the longest filter life.



Warning!

- Wear safety glasses when cleaning the filter.
- Do not puncture the filter.
- Clean the filter in a well-ventilated area.
- Wear appropriate dust mask to avoid breathing in dust.

1. Drive the machine on a level floor, engage the parking brake and turn the ignition key to “0”.
2. Open the battery/engine compartment hood with the handle and fasten it with the support rod.
3. Disconnect the battery connector (SW4000 Battery) - Disconnect the batteries (SW4000 Petrol/LPG).
4. Disconnect the vacuum system motor connector (A).
5. Disengage the retainers (B) and remove the vacuum system hood (C).

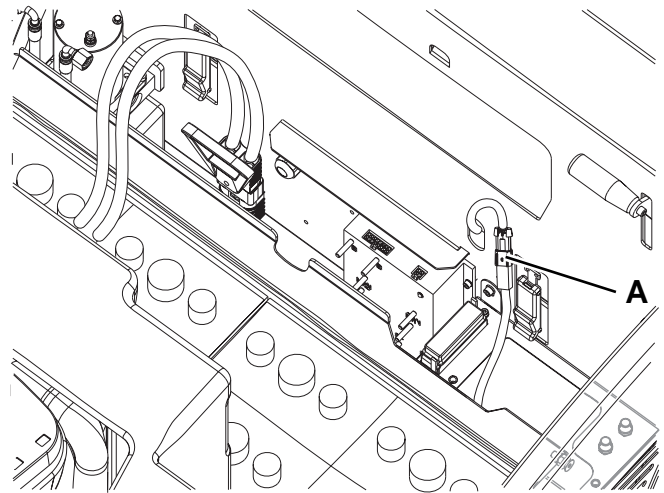
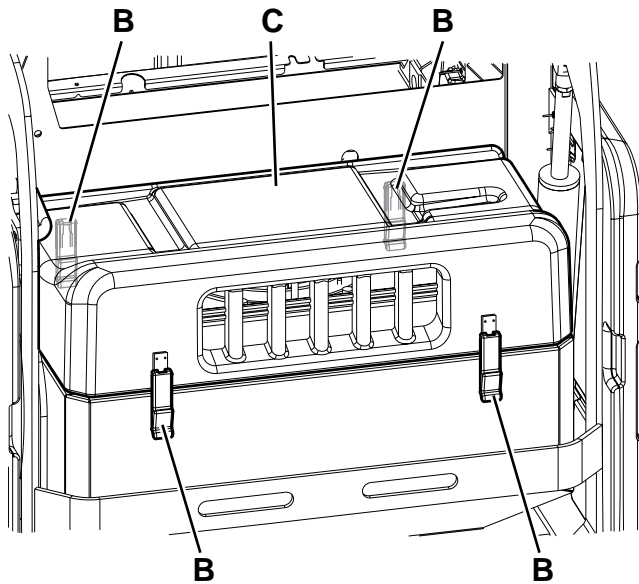

Panel Dust Filter Cleaning and Integrity Check (Continues)

6. (Only for LPG SW4000). Disconnect the filter shaker connector (K).
7. Loosen the knobs (D) and (E), then remove the filter shaker assembly (F), by sliding it forward, disengaging it by the knobs (D) and then by the knobs (E).
8. (Only for SW4000 Battery and Petrol). Fasten the filter shaker assembly (F) to the holder (G).
9. (Only for LPG SW4000). Remove the filter shaker assembly (F).
10. Lift the dust filter (H) and remove it from the machine.
11. Clean the dust filter using one of the methods below:

Method "A"

Vacuum loose dust from the filter. Gently tap the filter against a flat surface (with the dirty side down) to remove dust and dirt.



Caution! Take care not to damage the metal lip which extends past the gasket.

Method "B"

Vacuum loose dust from the filter. Blow compressed air (maximum pressure 6 Bar) into the clean side of the filter (in the opposite direction of the airflow).

Method "C"

Vacuum loose dust from the filter. Then soak the filter in warm water for 15 minutes, then rinse it under a gentle stream of water (maximum pressure 2.5 Bar). Let the filter dry completely before installing it back into the machine.

For a better cleaning, it is allowed to wash the filter with water and non-lathering detergents.

This provides better quality cleaning but reduces the life of the filter, which will have to be replaced more frequently. The use of inadequate detergents can damage the filter.



Caution! For paper filter: Do not use water or detergents to clean it, otherwise it can be damaged.

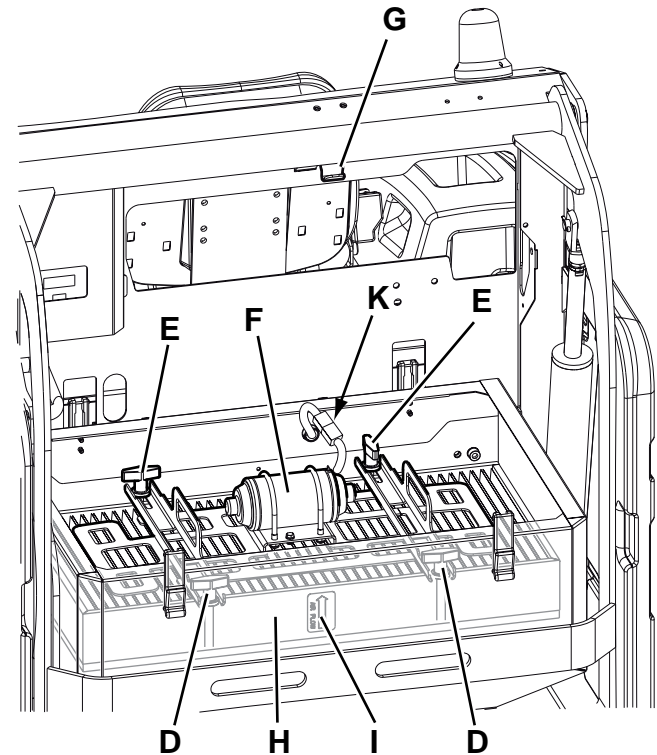

P200104

Troubleshooting

Trouble	Possible causes	Remedy
Dust/debris vacuuming is insufficient	The filter is clogged	Clean the dust filter by using the filter shaker or by disassembling it.
	The vacuum system compartment gasket is damaged	Repair/replace
No vacuuming	The fuse (F1) is open.	Replace the fuse.
	The switch (SW3) is not efficient	Replace
	The relay (K1) is not efficient	Replace
	The vacuum system is broken	Repair/replace
The filter shaker does not operate.	The fuse (F2) is open.	Replace the fuse.
	The filter shaker is disconnected.	Connect the filter shaker connector.
	The switch (SW3) is not efficient	Replace
	The relay (K2) is not efficient	Replace
	The filter shaker is broken	Repair/replace

Removal and Installation

Filter Shaker Motor Disassembly/Assembly

Disassembly

1. Drive the machine on a level floor, engage the parking brake and turn the ignition key to “0”.
2. Open the battery/engine compartment hood with the handle and fasten it with the support rod.
3. Disconnect the battery connector (SW4000 Battery) - Disconnect the batteries (SW4000 Petrol/LPG).
4. Disconnect the vacuum system motor connector (A).
5. Disengage the retainers (B) and remove the vacuum system hood (C).

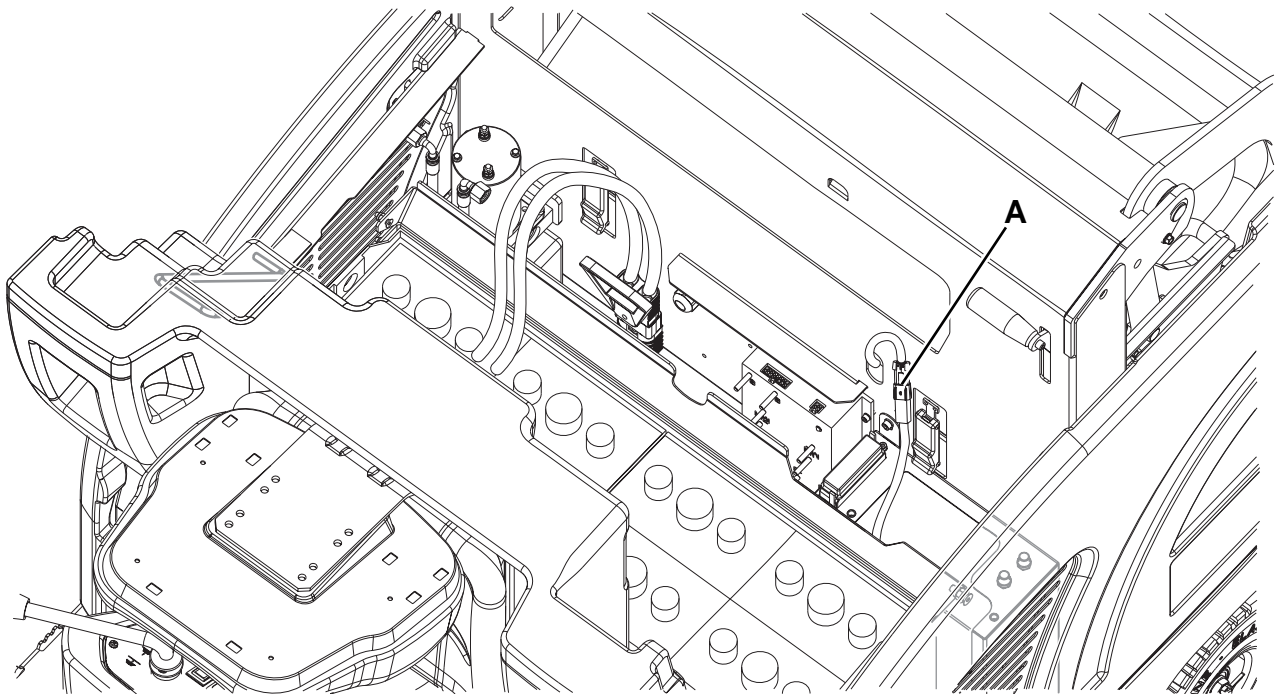

P200105

Filter Shaker Motor Disassembly/Assembly (Continues)

6. Release the fastening clamp and disconnect the filter shaker connector (K).
7. Loosen the knobs (D) and (E), then remove the filter shaker assembly (F), by sliding it forward, disengaging it by the knobs (D) and then by the knobs (E).
8. At the workbench, remove the nuts (G) and remove the fastening clamps (H) of the filter shaker motor (I). Retrieve the washers (J).
9. Remove the filter shaker motor (H), by disengaging the dowel (L) from its seat.

Assembly

10. Assemble the components in the reverse order of disassembly.

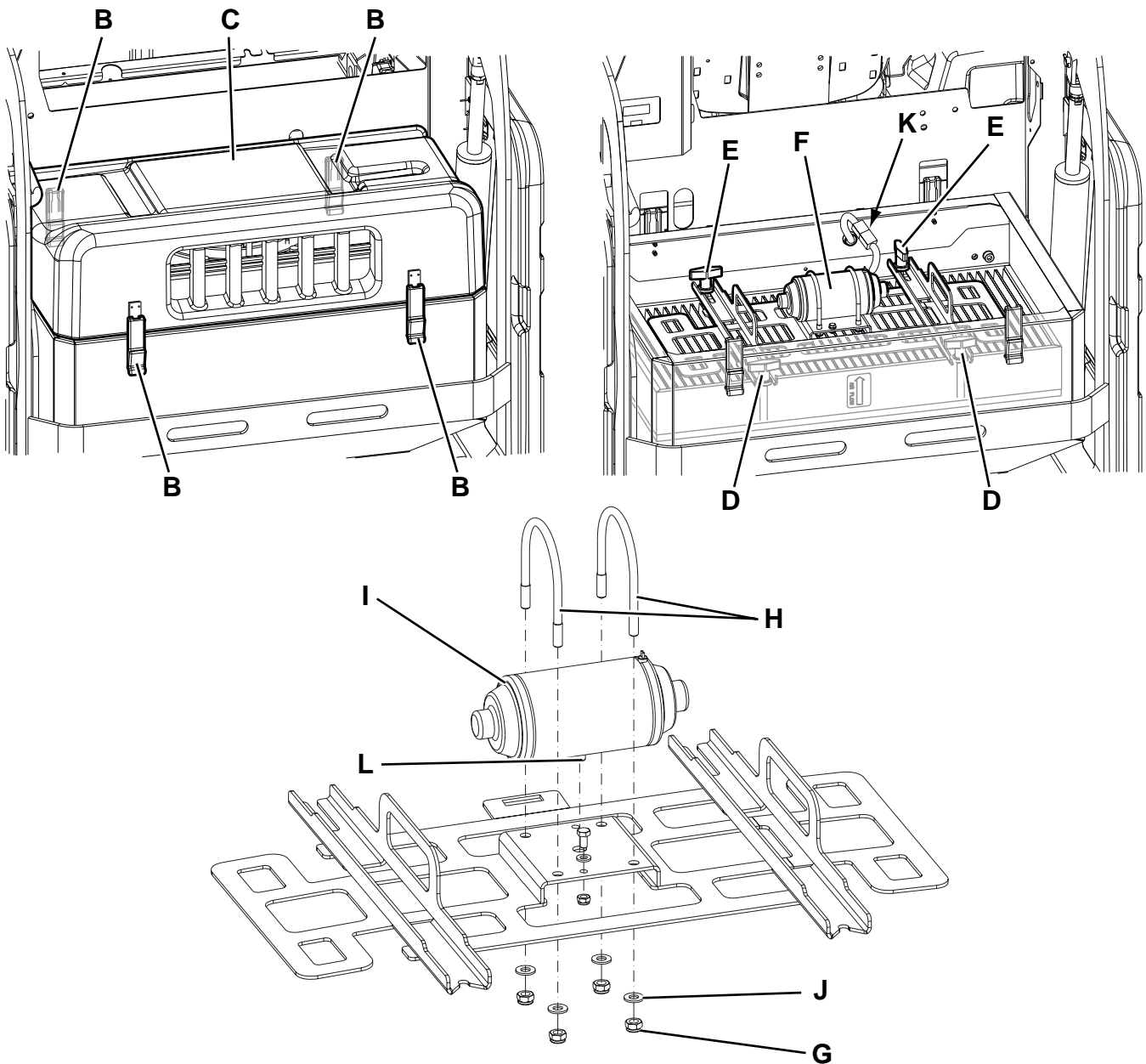

Electric Vacuum Fan Motor Amperage Check



Warning! This procedure must be performed by qualified personnel only.

1. Clean the dust filter.
2. Open the battery/engine compartment hood with the handle and fasten it with the support rod.
3. Apply the amp clamps (A) on one cable (B) of the electric vacuum fan (C).
4. Turn the ignition key to “I”.
5. With the help of an assistant, carefully press on the driver’s seat to activate the microswitch, then turn on the vacuum system and check that the electric fan motor amperage is within 7 and 9 A at 24 V.

Stop the vacuum system.

Turn the ignition key to “0”.

Remove the amp clamps (A).

If the amperage is higher, perform the following procedures to detect and correct it:

- Check that the F1 fuse is properly tightened
- Remove the electric fan motor (see the procedure in the next paragraph), and check the condition of all its components.

If the above-mentioned procedures do not produce the correct readings for the electric fan motor amperage, the motor must be replaced (see the procedure in the relevant paragraph).

Reassembly

6. Close the battery/engine compartment hood.

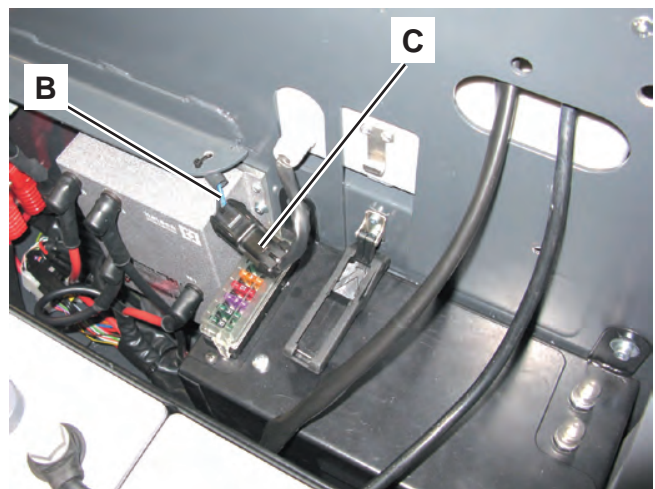
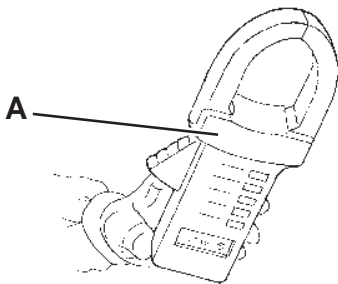

Electric Fan Disassembly/Assembly

Disassembly

1. Drive the machine on a level floor, engage the parking brake and turn the ignition key to “0”.
2. Open the battery/engine compartment hood with the handle and fasten it with the support rod.
3. Disconnect the battery connector (SW4000 Battery) - Disconnect the batteries (SW4000 Petrol/LPG).
4. Disconnect the vacuum system motor connector (A).
5. Disengage the retainers (B) and remove the vacuum system hood (C).

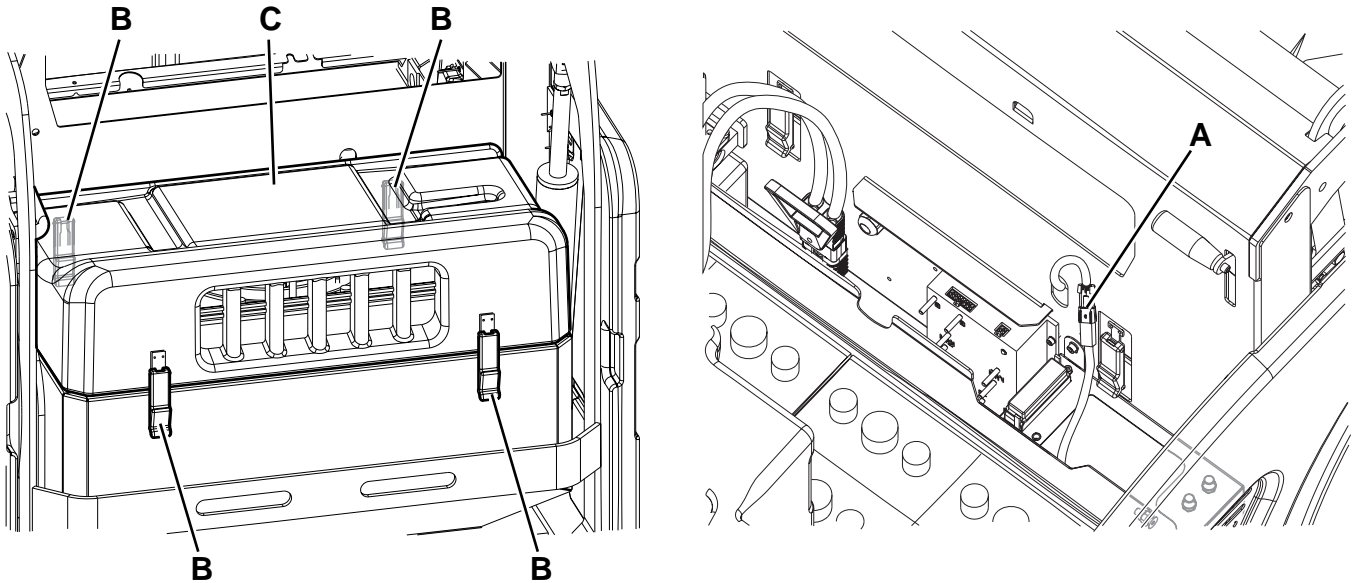

P200108

Electric Fan Disassembly/Assembly (Continues)

6. At the workbench, disconnect the connector (D) from the electrical cable (E), by disengaging its pins.
7. Unscrew the bulkhead cap (F).
8. Remove the external screws (G) and remove the electric fan assembly (H) with its wiring harness (E).
9. If necessary, remove the electric vacuum fan (I) from the assembly (H) as shown below.
 - Unscrew the three nuts (J) and remove the screws (K).
 - Remove the plate (L) and the electric fan (I).

Assembly

10. Assemble the components in the reverse order of disassembly.

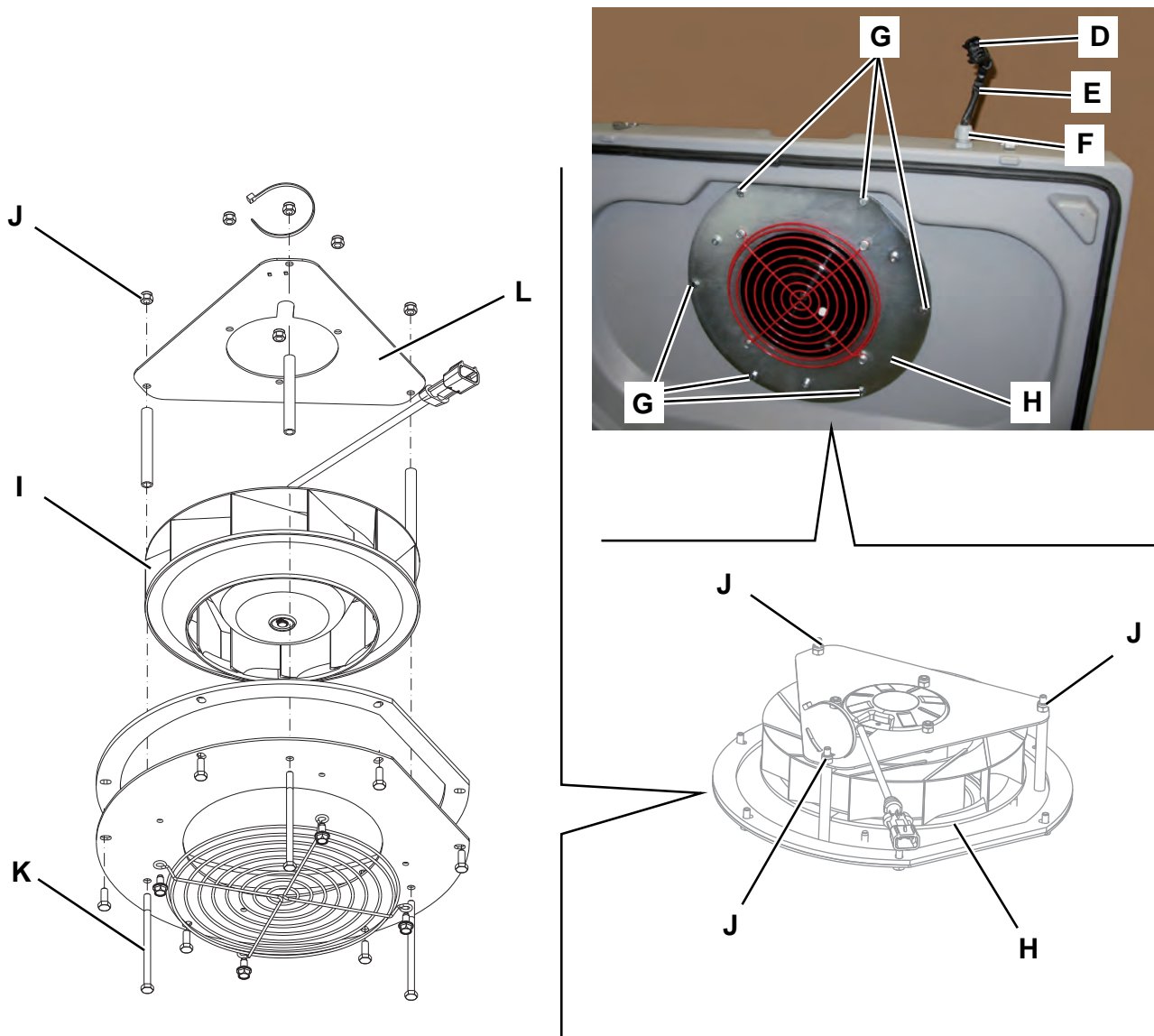

Specifications

Dust Control System	Values		
	SW4000 Battery	SW4000 Petrol	SW4000 LPG
Vacuum system motor	0.35 hp (260 W) - 3,000 rpm		
Filter shaker motor	0.12 hp (90 W) - 6,000 rpm		
BIA C polyester dust filter	75 ft ² (7 m ²)		
Paper dust filter	75 ft ² (7 m ²)		
Main broom compartment vacuum	0.6 in H ₂ O (14 mm H ₂ O)		

Dust Guard System

Functional Description

The dust guard system sprays a thin film of water in front of each side broom, thus minimizing the dust raised by the broom itself.

The water used by the dust guard system is in a tank to be found inside the front column.

The water tank is connected to the machine hose system by means of a quick coupling equipped with an integrated valve, which allows to disconnect the tank without causing any water leaks.

The system has a pump motor (M8) which is powered by the relay (K6) and protected by the fuse (F5).

The relay (K6) is directly activated by the dust guard system switch (SW8) which powers also the warning light (A) which signals the function activation on the dashboard electronic board (EB2).

By turning on the switch in the panel besides the operator, the pump, which is under the machine bed, collects water from the tank inside the front column; through the hoses, the water reaches the nozzles which spray it on the side brooms.

The relay (K6), and then the system, turns only when the main broom is turning.

When the main broom is off, the water pump turns off automatically.

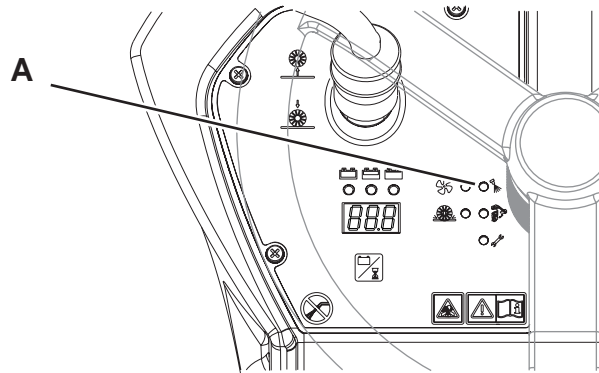

P200224

Wiring Diagram

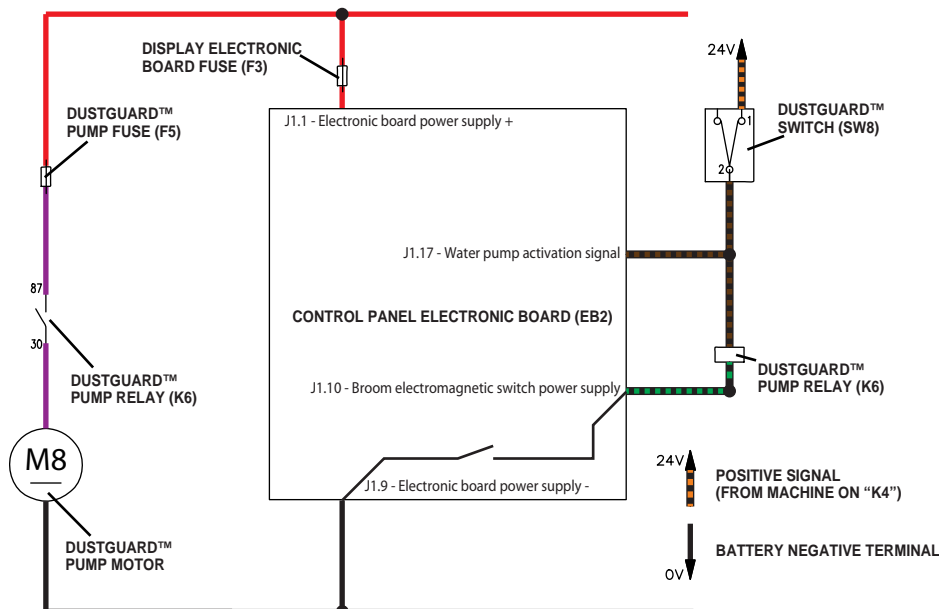

P200110

Component Locations

- Dust guard system switch (SW8)
- Water tank
- Tank filler
- Water pump (M8)
- Water filter
- Spraying nozzle
- Dust guard system fuse (5 A) (F5)

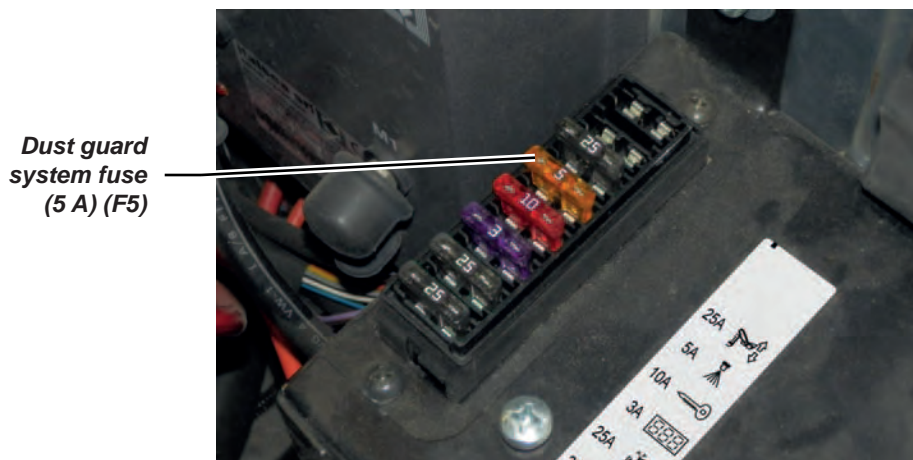
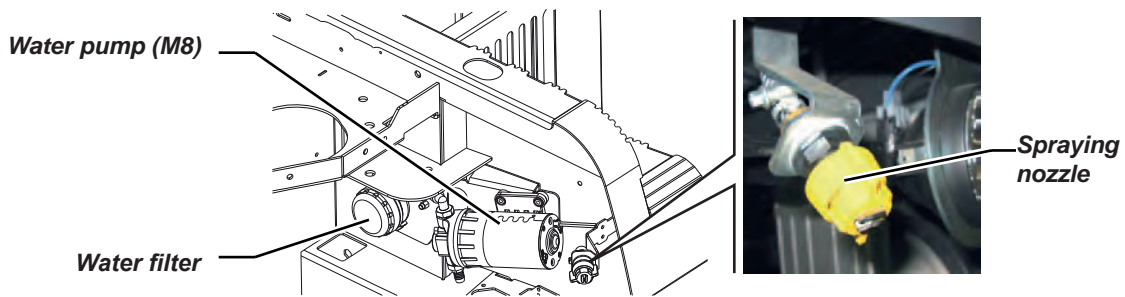
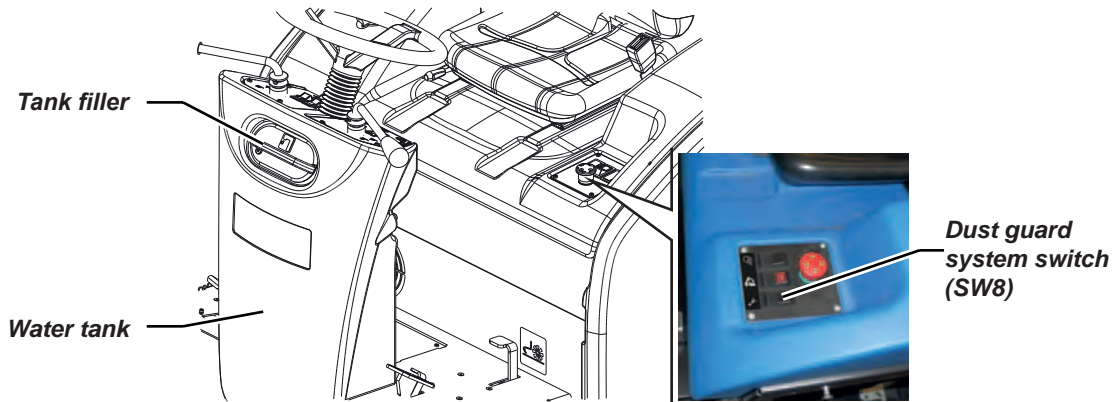

Maintenance and Adjustments

Dust guard System Water Filter Cleaning



Note: To prevent water from flowing out when cleaning the filter, turn on the dust guard system and empty the system tank.

1. Drive the machine on a level floor.
2. Turn the ignition key to “0” and engage the parking brake.
3. Operating in the area (A) of the machine, reach the water filter assembly (B) of the dust guard system.
4. Unscrew and remove the transparent cover (C) with the gasket (D), then remove the filter strainer (E).
5. Clean and install them on the holder (F).



Note: Install the gasket (D) and the filter strainer (E) properly on the transparent cover (C) and on the holder (F).

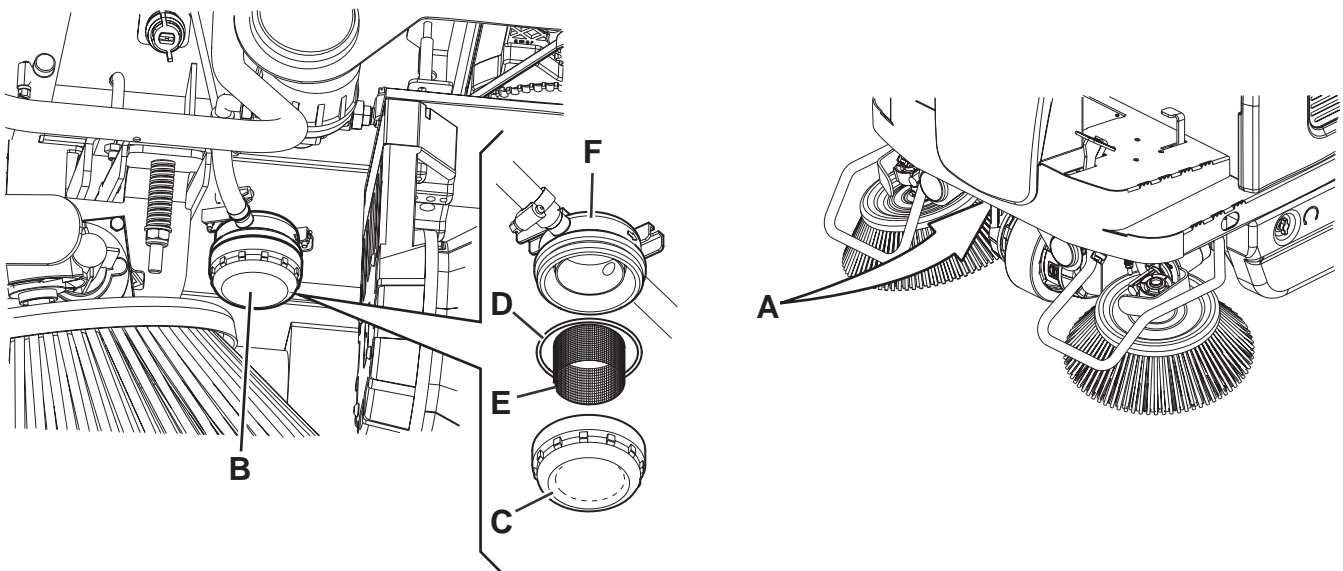

Nozzle and Filter Cleaning

1. Drive the machine on a level floor.
2. Turn the ignition key to “0” and engage the parking brake.
3. On the front side of the side brooms, remove the ring nuts (A) (bayonet joint).
4. Remove and clean the nozzles (B), the gaskets (D) and the filters (C) with compressed air. Remove any calcium deposit. If necessary, replace the filters (C).
5. Reinstall the filters, gaskets and the nozzles, then fasten them with the ring nuts.

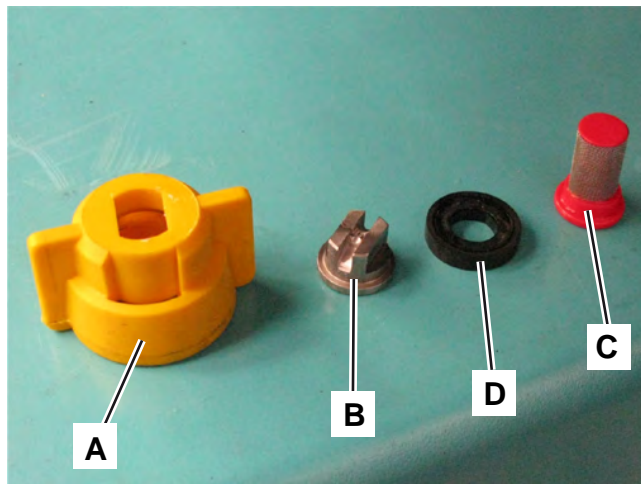
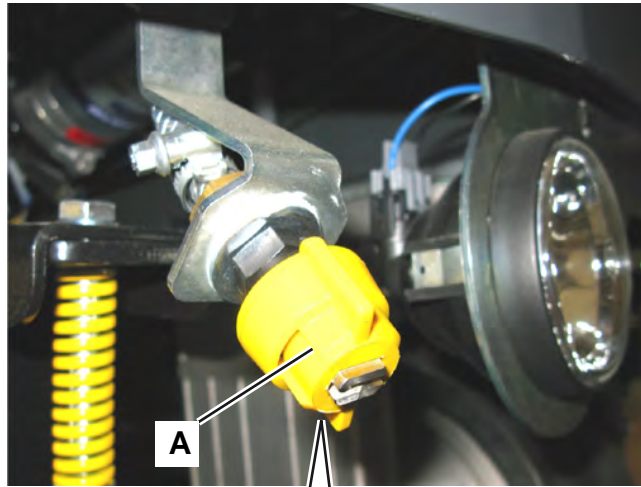

Troubleshooting

Electrical components	Electrical components	Values
Little water comes out from the spray nozzles	The filter and/or nozzle is clogged	Clean/replace
	The water filter is clogged	Clean/replace
	The pump is not working	Repair/replace
No water to the nozzles	The water filter is clogged	Clean/replace
	The fuse (F5) is open	Replace
	The relay (K6) is not efficient	Replace

Removal and Installation

Dust guard System Water Pump Disassembly/Assembly

Disassembly

1. If possible, place the machine on a hoisting system.
2. Turn the ignition key to “0” and engage the parking brake.
3. Open the battery/engine compartment hood with the handle and fasten it with the support rod. Disconnect the battery connector (SW4000 Battery) - Disconnect the batteries (SW4000 Petrol/LPG).
4. Lift and disassemble the right side bulkhead.
5. On the right front upper side of the machine bed, remove the fastening screws (A) and (B) of the dust guard system water pump support plate.

(For SW4000 Battery) If the screws (B) are hidden under the battery, the battery has to be removed (see the procedure in the Electrical System chapter).

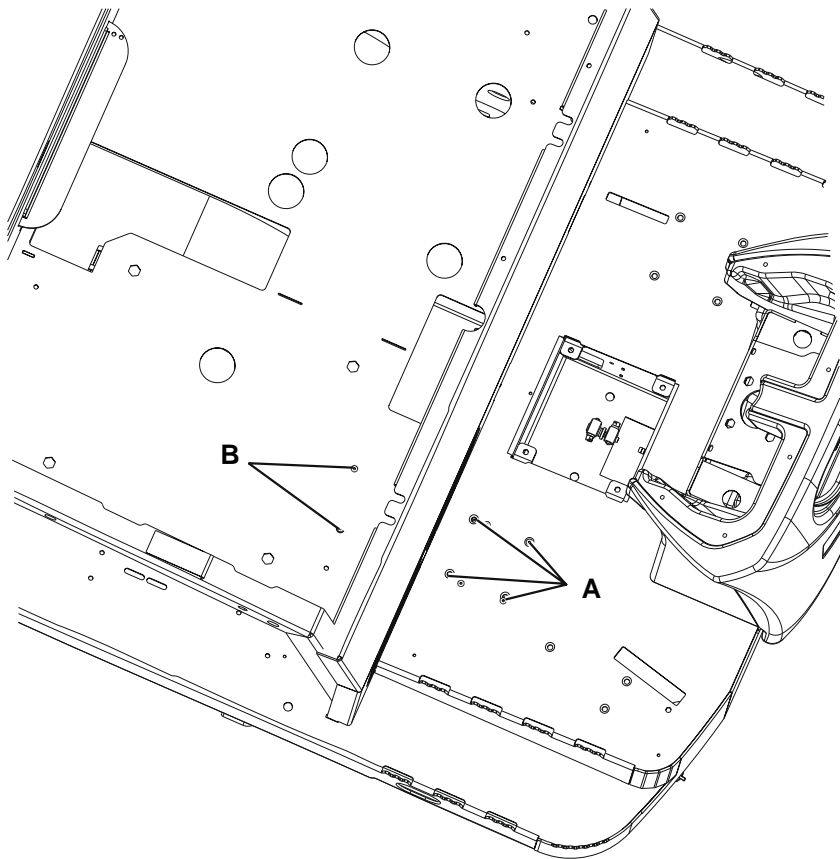

Dust guard System Water Pump Disassembly/Assembly (Continues)

6. On the right front upper side of the machine bed, disconnect the hose (C) of the water pump (D); disconnect the filter assembly input hose (E).
7. Disconnect the connector (F) of the water pump (D).
8. Remove the holder assembly with pump and filter (G).
9. If necessary, at the workbench, unscrew the four screws (H), disconnect the hose (I), then remove the water pump (D) from the holder.

Assembly

10. Assemble the components in the reverse order of disassembly.

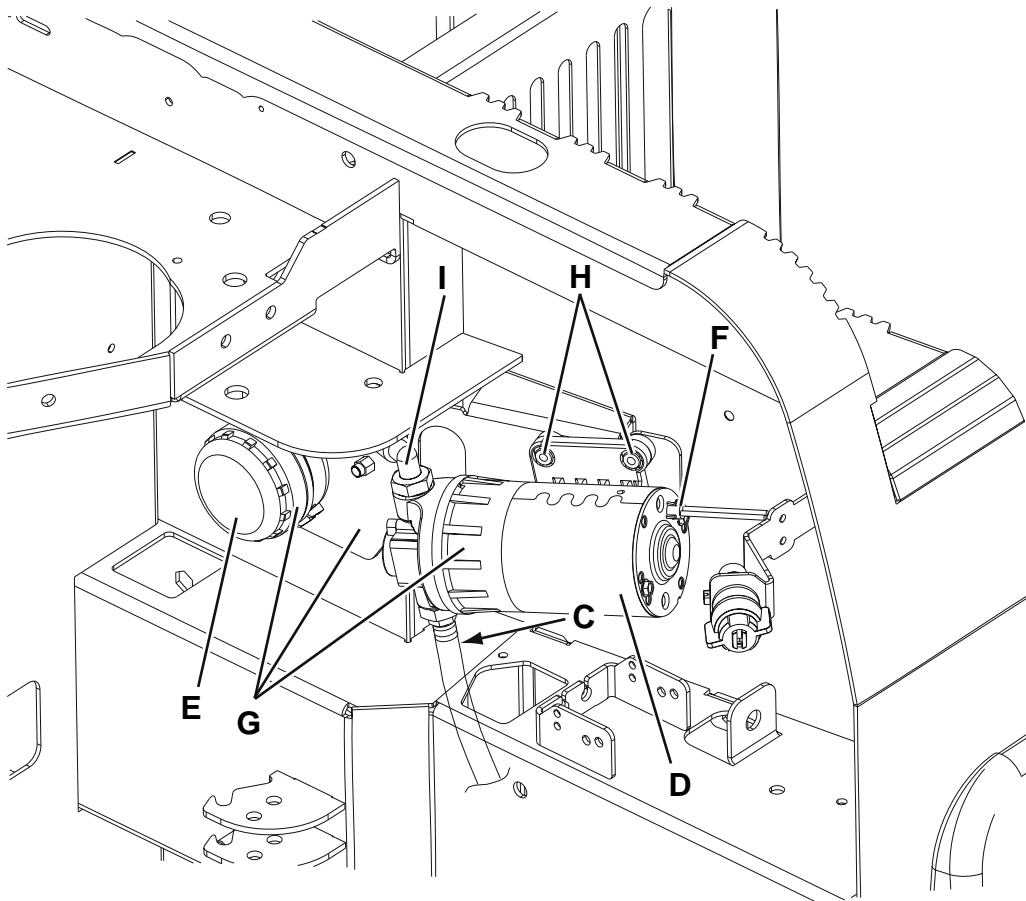

Specifications

Dust Guard System	Values		
	SW4000 Battery	SW4000 Petrol	SW4000 LPG
Water tank capacity	5.3 US gal (20 liters)		
Pump	3A - 24V - 1.5 gpm US - 49 psi (3A - 24V - 5.7 l/min - 3.4 bar)		

Electrical System

Functional Description

(SW4000 Battery)

The electrical system is basically an electromechanical system at 24Vdc rated voltage in which the main part of the accessories are powered by relays controlled by switches. The timing control of certain accessories and battery charging, as well as the display of the warning lights, takes place by dashboard electronic board (EB2). The drive system consists of a driving wheel (M0) driven by the drive system electronic board (EB1).

The battery is connected to the system by means of the ANDERSON POWER connector (C1). Downstream of the connector, there is a safety fuse (F0). The fuse is sized to activate only in case the power side of the wiring harness becomes seriously damaged.

The on board battery charger (CH) is directly connected on the battery pins for the power side, to connector (C2) for the inhibition signal. When the battery charger is not connected to the electrical mains, the relay inside the battery charger closes the contact between the 2 wires connected to (C2), this contact opens when the battery charger is connected to the electrical mains. When the battery charger is not installed, the connector (C2) is closed by a jump connection. The connector contacts (C2) are upstream of the ignition key (SW1) and cut off the power supply to all control section of the electrical system.

For further details, see the descriptions of individual sub-systems.

(SW4000 Petrol/LPG)

The electrical system of Petrol/LPG versions is substantially equal to that of the battery versions, the difference is that the 24V battery pack is replaced by one with lower capacity (2 12Vdc starter batteries) kept charged by a dynamo and a power diode. The system guarantees a correct charging and battery management on the condition that the rpm of the engine are as constant as possible and that the use of the machine is as regular as possible, avoiding long stops (not more than 5 minutes) with the engine switched on and the accessories off, and long periods (not more than 10% utilization of the machine) with all accessories turned on to their maximum load.

When the above conditions are not met, if the batteries are under abnormal voltages, a protection system warns the operator by means of the dashboard electronic board display (EB2) (see Control System chapter).

The dynamotor (M5) also acts as an electric starter for the engine, when powered by the electromagnetic switch (ES2), which is activated when the ignition switch (SW1) is turned to position II (Ignition).

Fuses

All circuits and components are protected by fuses, located inside or outside the electrical component box. To protect motors from overloads when using the machine, there are manually resettable fuses (side brooms) or fuses interlocked to electronic protection systems (main broom, see Main Broom Motor Protection in Dashboard Electronic Board Specifications chapter).

All the circuits are protected by non-resettable fuses.

Pos.	Type	Battery Versions		Petrol and LPG Versions	
		Nominal Size	Protected Function	Nominal Size	Protected Function
F0	Not resettable	150	GENERAL	150	GENERAL
FA	Not resettable	50	MAIN BROOM	50	MAIN BROOM
FC	Not resettable	-	-	80	BATTERY/DYNAMOTOR RECHARGE
FR1	Resettable	15	RIGHT SIDE BROOM	15	RIGHT SIDE BROOM
FR2	Resettable	15	LEFT SIDE BROOM	15	LEFT SIDE BROOM
F1	Not resettable	25	VACUUM SYSTEM	30	VACUUM SYSTEM
F2	Not resettable	25	FILTER SHAKER	30	FILTER SHAKER
F3	Not resettable	3	KEY CIRCUIT	3	KEY CIRCUIT - EV LPG
F4	Not resettable	10	HORN - PIVOTING LIGHT - HEADLIGHT	10	HORN - PIVOTING LIGHT - HEADLIGHT
F5	Not resettable	5	WATER PUMP	5	WATER PUMP
F6	Not resettable	25	HOPPER PUMP	30	HOPPER PUMP
F7	Not resettable	25	SPARE	30	SPARE
F8	Not resettable	10	SPARE	10	SPARE

SW4000 BATTERY

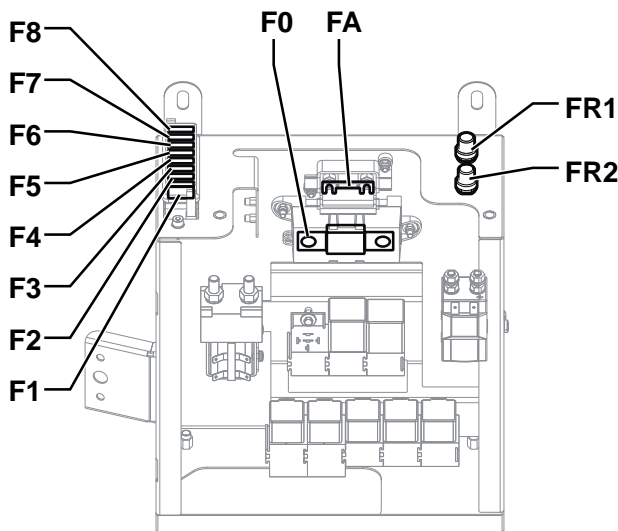

SW4000 PETROL / LPG

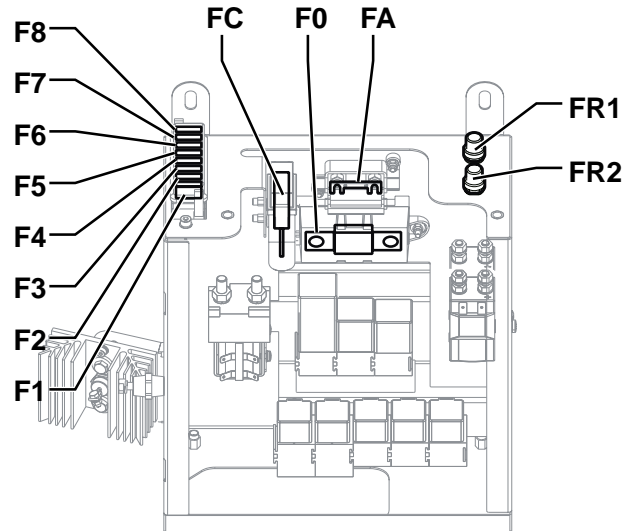

Relay/Electromagnetic Switch/Diodes

Pos.	Battery Versions		Petrol and LPG Versions	
	Nominal Size	Protected Function	Nominal Size	Protected Function
K1	40A	VACUUM SYSTEM RELAY	40A	VACUUM SYSTEM RELAY
K2	40A	FILTER SHAKER RELAY	40A	FILTER SHAKER RELAY
K3A	30/40A	HOPPER LIFTING	30/40A	HOPPER LIFTING RELAY
K3B	30/40A	HOPPER LOWERING	30/40A	HOPPER LOWERING RELAY
K4	30/40A	MACHINE ON RELAY	30/40A	MACHINE ON RELAY
K5	30/40A	SIDE BROOM RELAY	30/40A	SIDE BROOM RELAY
K6	30/40A	DUSTGUARD™ PUMP RELAY	30/40A	DUSTGUARD™ PUMP RELAY
KT1	-	-	5A	LPG SAFETY RELAY (only for LPG)
ES0	120A	LINE ELECTROMAGNETIC SWITCH	120A	LINE ELECTROMAGNETIC SWITCH
ES1	70A	MAIN BROOM ELECTROMAGNETIC SWITCH	70A	MAIN BROOM ELECTROMAGNETIC SWITCH
ES2	-	-	70A	ENGINE START ELECTROMAGNETIC SWITCH
D1	-	-	-	DIODE ELECTRONIC BOARD

SW4000 BATTERY

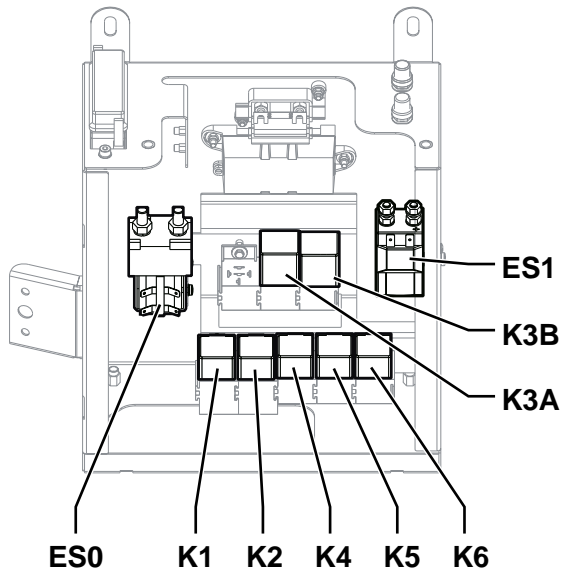

SW4000 PETROL / LPG

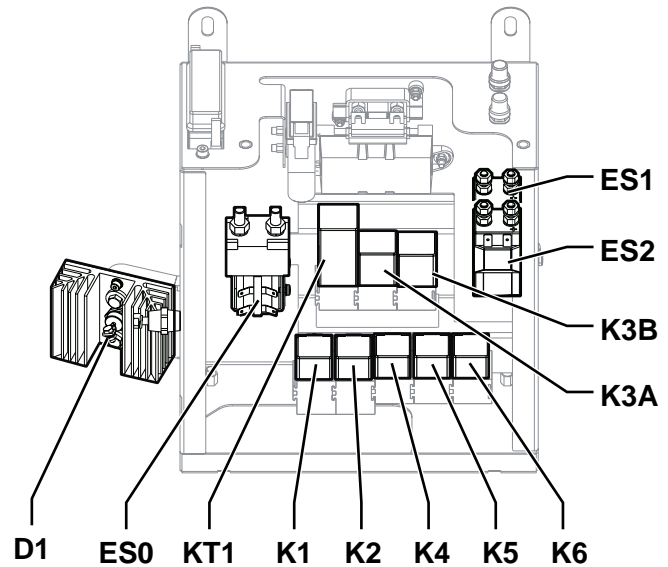

Wiring Diagram (SW4000 Battery)

WITHOUT ON BOARD BATTERY CHARGER

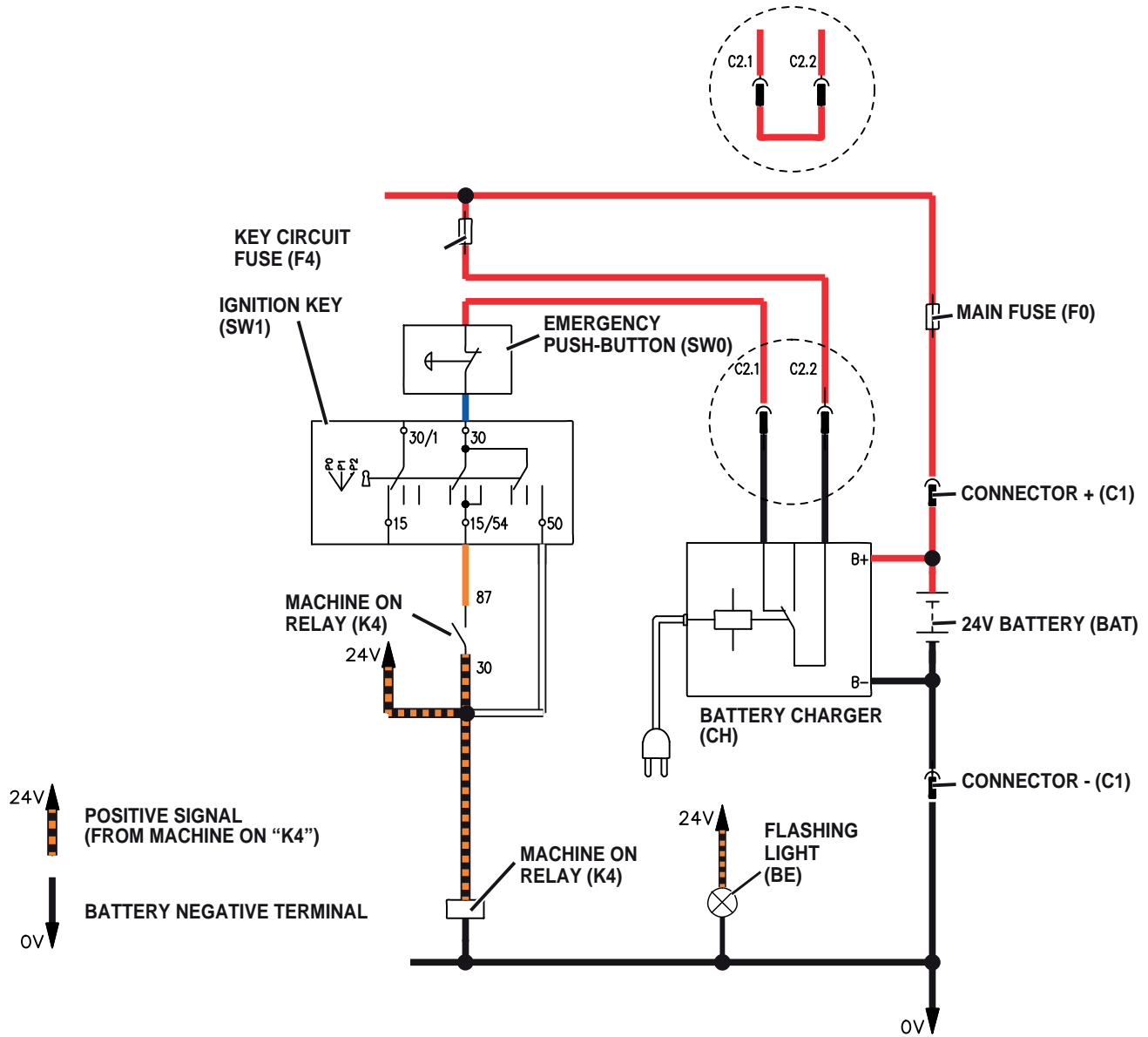

Wiring Diagram (SW4000 Petrol/LPG)

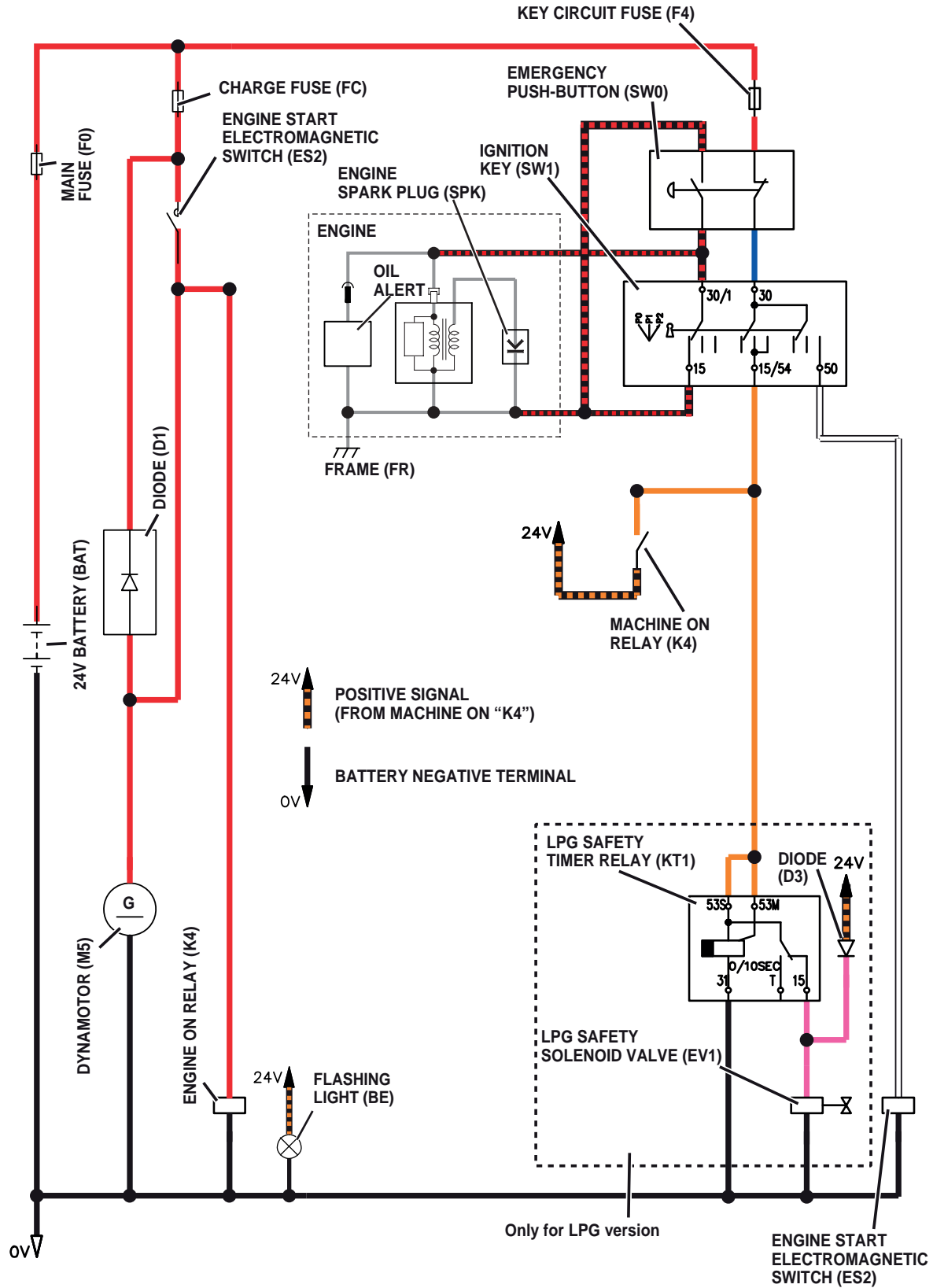

Component Locations (SW4000 Battery)

- Emergency push-button (SW0)
- Battery charger (CH)
- Flashing light (BE)
- Batteries (BAT)
- Wiring harnesses
- Electrical component box
- Battery connector (C1)

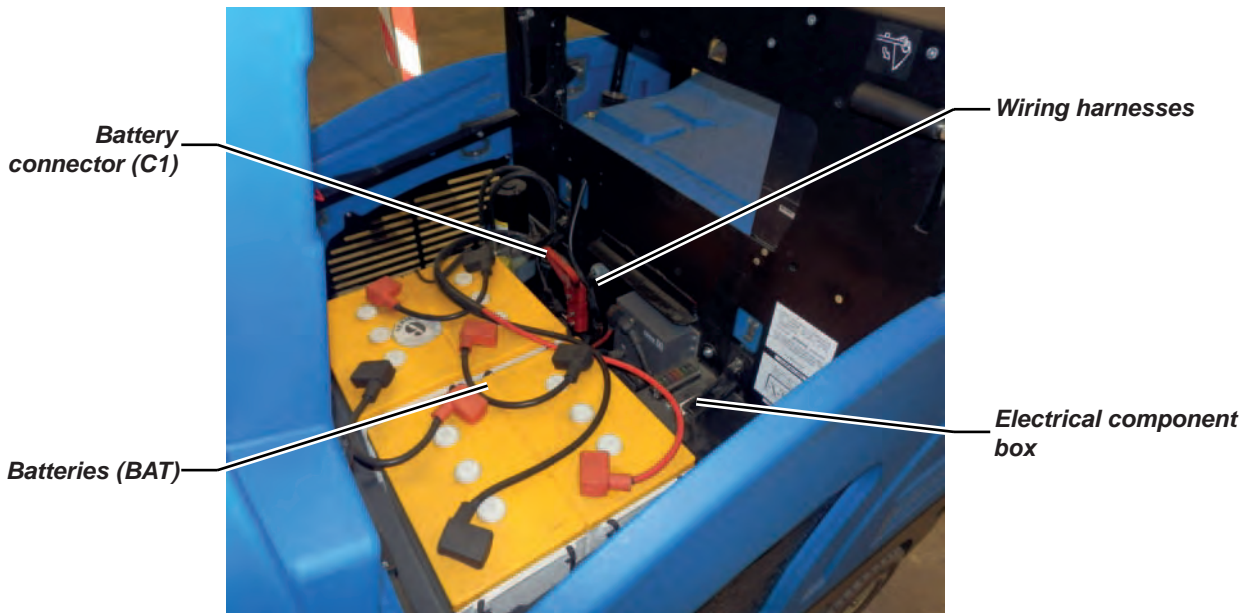
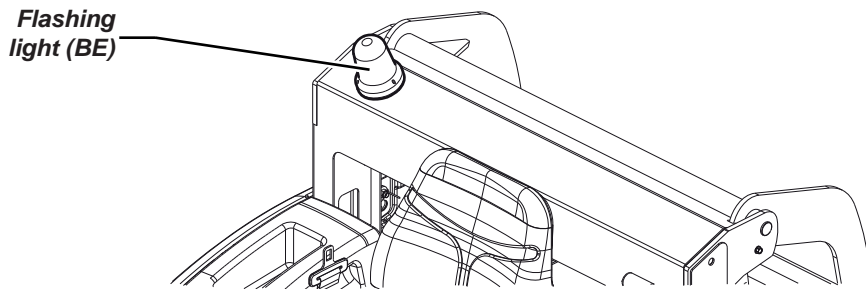
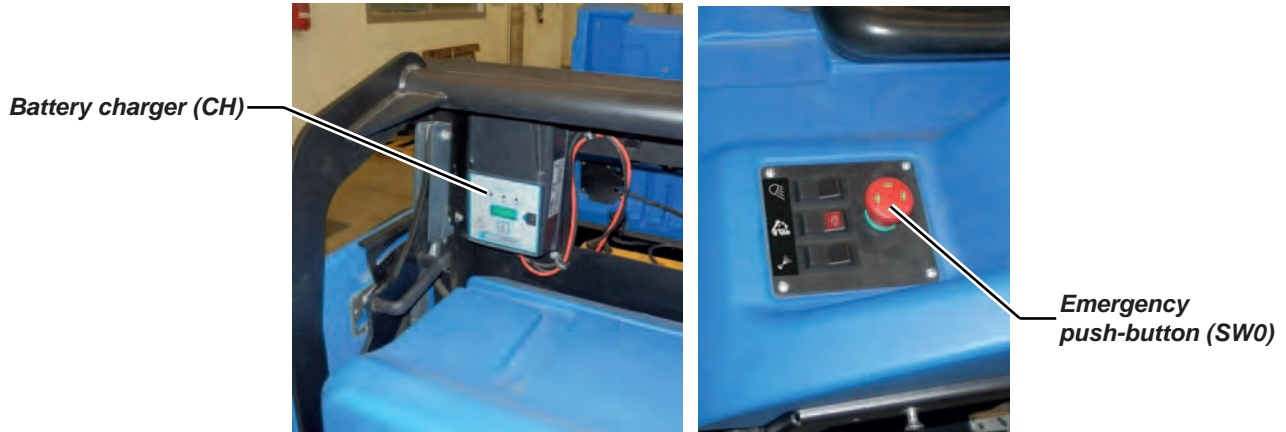

Component Locations (SW4000 Petrol/LPG)

- Emergency push-button (SW0)
- Wiring harnesses
- Flashing light (BE)
- Electrical component box
- Batteries (BAT)
- Dynamotor (M5)
- 8-way fuse holder
- Main broom motor fuse (50 A) (FA)
- Main fuse (150 A) (F0)
- Right side broom motor fuse (15 A) (FR1)
- Left side broom motor fuse (15 A) (FR2)
- (SW4000 P/LPG) Battery charge fuse (80 A) (FC)



Emergency push-button (SW0)

Flashing light (BE)

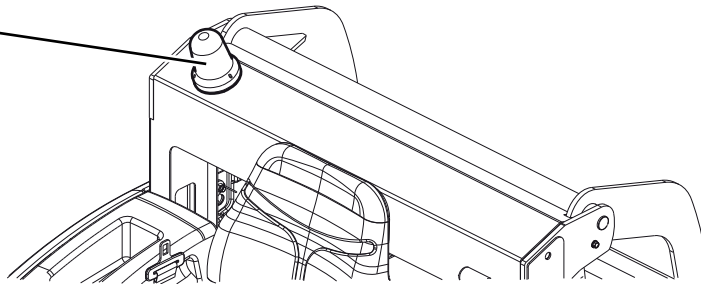

Dynamotor (M5)

Wiring harnesses

Batteries (BAT)

Electrical component box

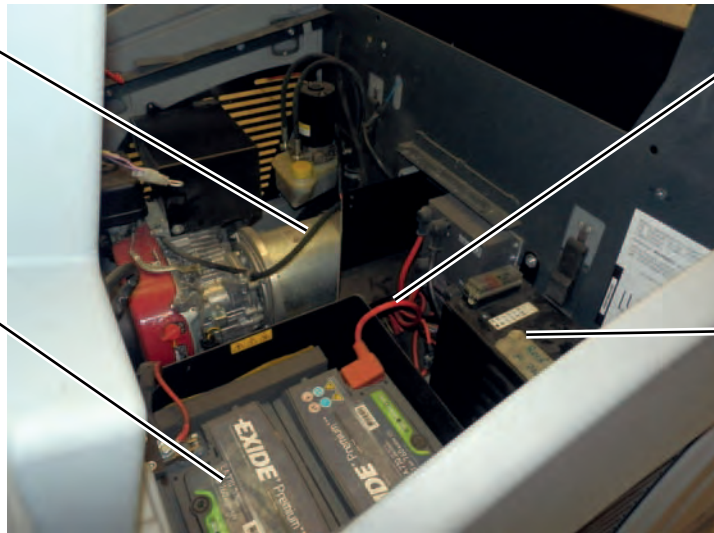

8-way fuse holder

Right side broom motor fuse (15 A) (FR1)

(SW4000 P/LPG) Battery charge fuse (80 A) (FC)

Left side broom motor fuse (15 A) (FR2)

Main fuse (150 A) (F0)

Main broom motor fuse (50 A) (FA)

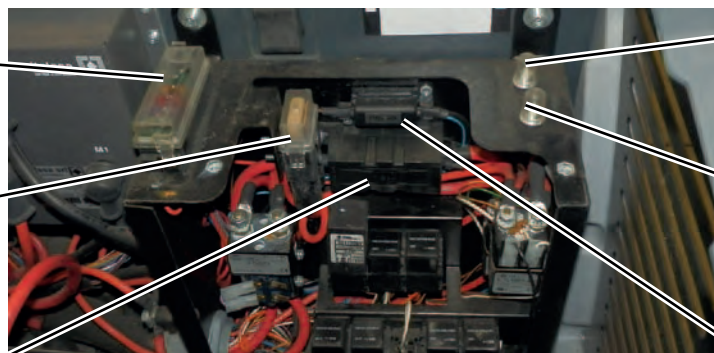

Component Locations (Continues)

- Hopper lifting fuse (25 A - Battery) (30 A Petrol/LPG) (F6)
- Dust guard system fuse (5 A) (F5)
- Main fuse (key circuit) (10 A) (F4)
- Display electronic board fuse (3 A) (F3)
- Filter shaker motor fuse (25 A - Battery) (30 A Petrol/LPG) (F2)
- Vacuum system motor fuse (25 A - Battery) (30 A Petrol/LPG) (F1)

SW4000 Battery

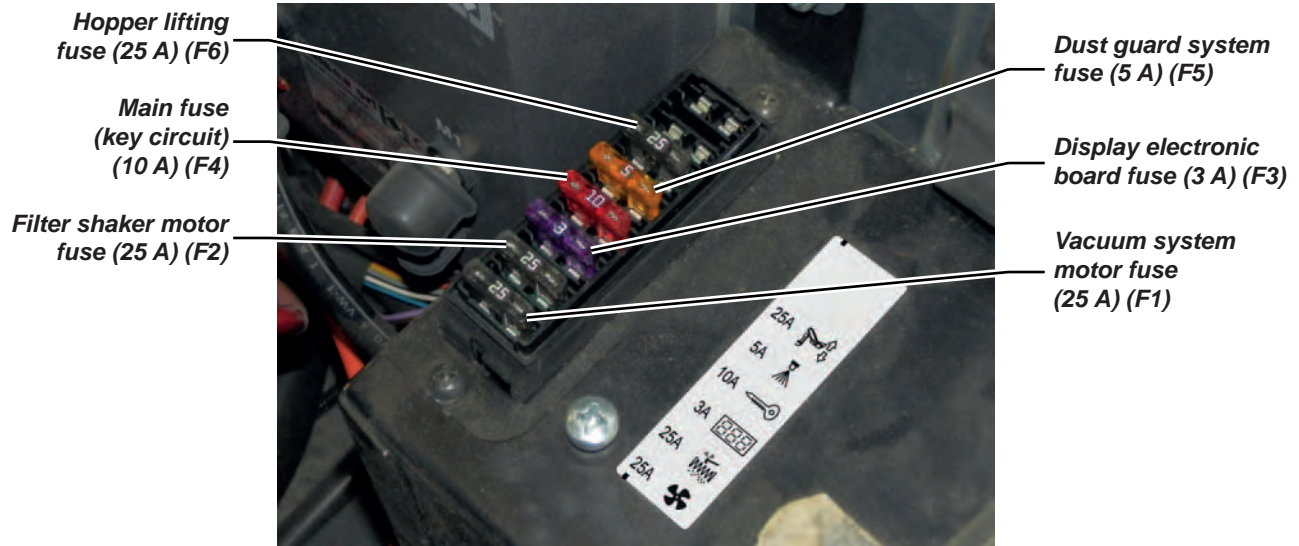

SW4000 Petrol / LPG

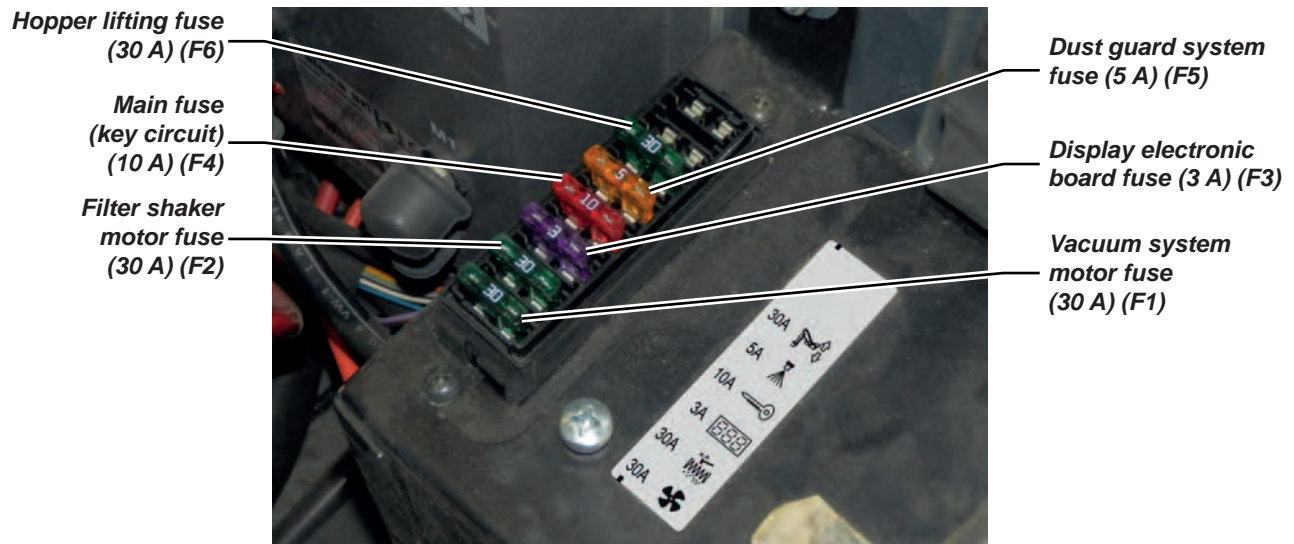

Maintenance and Adjustments

Battery Voltage Display (SW4000 Battery)

By pressing the push-button (A) (with the machine running) the display will switch from the 3-digit hour counter (B) to the battery voltage. The display will automatically return to the hour counter "5" after the last pressing of the push-button (A).

Battery Charge Status Display (SW4000 Battery)

Battery charge status is shown by the 3 LEDs depending on the type of battery (WET or GEL/AGM) according to the following diagram:

		WET	GEL-AGM
1	Green LED on (fixed)	V>22.0	V>22.2
2	Yellow LED on (fixed)	22.0>V>20.4	22.2>V>21.6
3	Red LED flashing	V>20.4	V>21.6

(*) When the red LED starts flashing, broom function is automatically deactivated.

Battery Type Display (WET or GEL-AGM) (SW4000 Battery)

Each time the machine is turned on with the ignition key, the 3 battery charge LED indicators show the battery type as follows:

Battery Type	Flashing pattern
WET	4 flashes of the RED warning light
GEL-AGM	4 flashes of the GREEN warning light

On Board Battery Charger Setting (SW4000 Battery)

EXTERNAL SWITCH (C)	INTERNAL DIPSWITCHES (D) (*)								CHARGING CURVES
	DIP1	DIP2	DIP3	DIP4	DIP5	DIP6	DIP7	DIP8	
WET	OFF	ON/OFF	ON/OFF	ON/OFF	OFF	OFF	OFF	ON	IU1a Pb-Acid Wet (SPE specifications)
GEL-AGM	OFF	ON	ON	ON	OFF	OFF	OFF	ON	IUUa Gel-AGM generic (SPE specifications) (DEFAULT)
GEL-AGM	OFF	ON	ON	OFF	OFF	OFF	OFF	ON	IU1a EXIDE approved
GEL-AGM	OFF	OFF	ON	OFF	OFF	OFF	OFF	ON	IUUo OPTIMA approved
GEL-AGM	OFF	ON	OFF	OFF	OFF	OFF	OFF	ON	IU1a AGM DISCOVER approved
GEL-AGM	OFF	OFF	OFF	OFF	OFF	OFF	OFF	ON	IU1a AGM FULLRIVER approved

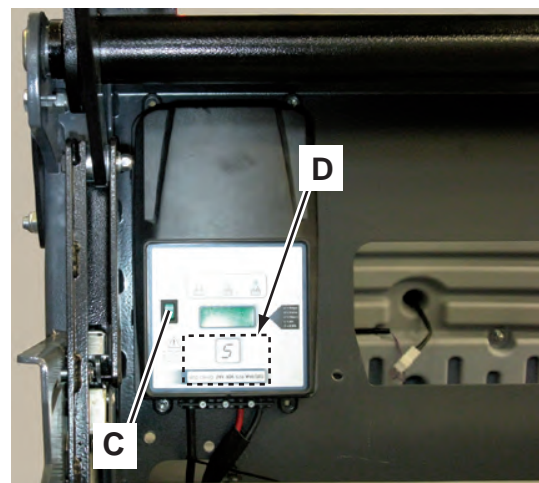
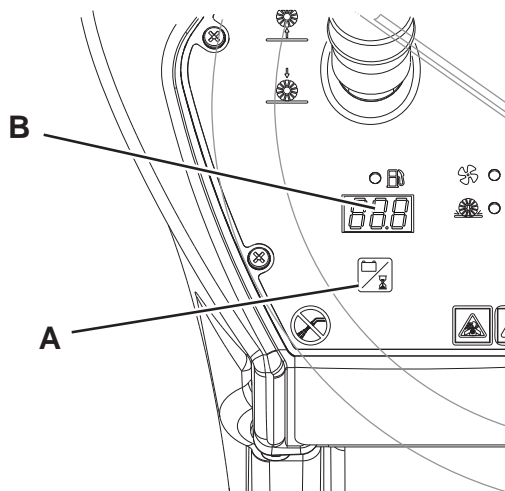

(*) Located under the label, in the dotted area

Battery Removal/Installation and Battery Type Setting (WET or GEL/AGM) (SW4000 Battery)



Warning! Do not tilt the lead batteries (WET) to prevent the highly corrosive acid from leaking out of the batteries. Do not connect, not even accidentally, the battery positive and negative terminals by using tools, keys, etc. This could cause dangerous short-circuits.

Battery Installation

For approved battery types, see the Technical Data paragraph.

The batteries must be installed as shown in the diagram (A).

According to the battery dimensions, check if it is possible to place them inside the relevant plastic container, supplied with the machine.

If the batteries are larger than the container, use the square guides, supplied with the machine, to ensure the stability inside the battery compartment.



Warning! Non-sealed WET batteries always need an appropriate container to prevent the acid from leaking. Do not install the WET batteries without an appropriate container.

1. Engage the parking brake.
2. Check that the ignition key has been removed.
3. Open the battery compartment hood (A) with the handle (B) and fasten it with the support rod (C).
4. Disconnect the battery connector (D).
5. With the help of an assistant and an appropriate hoisting system, install the batteries (E) and connect them as shown in the diagram (F).
6. Connect the batteries according to the diagram (F).
7. Connect the battery connector (D).
8. Set the battery type (WET or GEL-AGM), according to the following procedure.

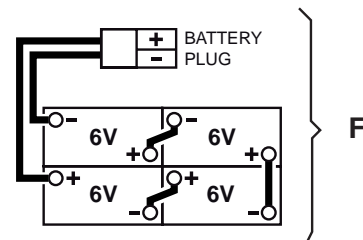
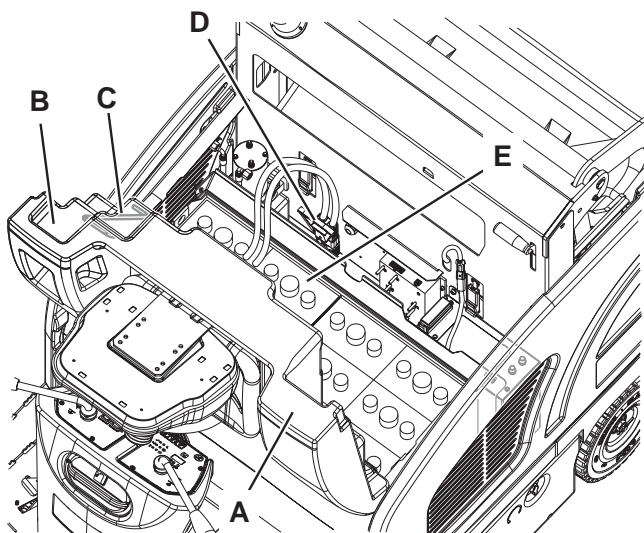

Battery Removal/Installation and Battery Type Setting (WET or GEL/AGM) (SW4000 Battery) (Continues)

Battery Setting (WET or GEL-AGM)

9. Remove the support rod and close the battery compartment hood with the handle.
10. Turn the ignition key to “I” by pressing the push-button (G) and by holding it (for about 5”) until the warning light corresponding to the current setting flashes:
 - Red warning light (H): WET batteries
 - Green warning light (I): GEL-AGM batteries
11. Release and press again the push-button (G) within 5 seconds to change setting.
12. Wait until the warning light corresponding to the new setting stops flashing (5 seconds approx.).
13. The new setting is properly stored.
14. Set the type of batteries (WET or GEL-AGM) on the battery charger (K) (if equipped) too by activating the relevant selector (L).

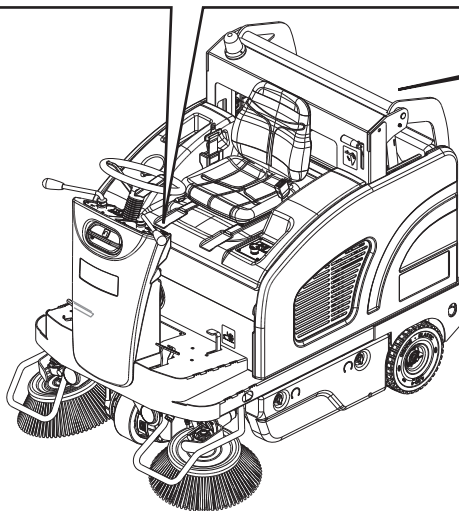
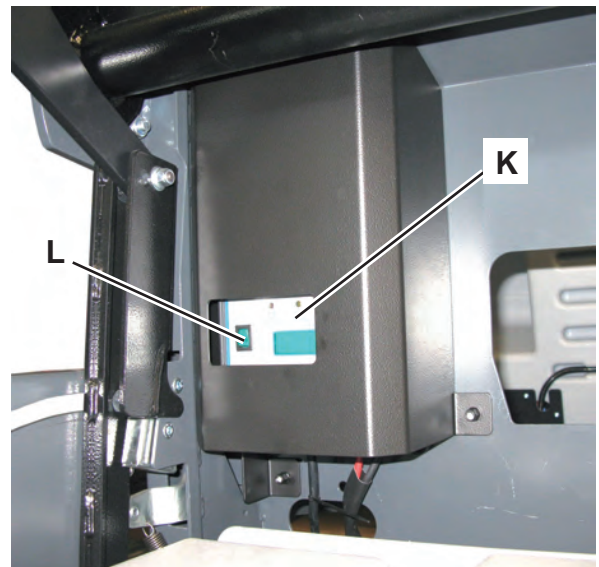
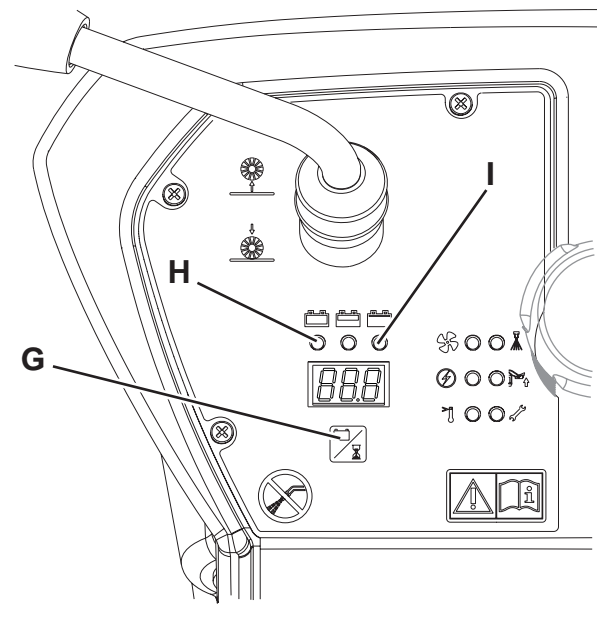

Battery Removal/Installation and Battery Type Setting (WET or GEL/AGM) (SW4000 Battery) (Continues)

Battery Removal

1. Engage the parking brake.
2. Remove the ignition key.
3. Open the battery compartment hood (A) with the handle (B) and fasten it with the support rod (C).
4. Disconnect the battery connector (D).
5. Disconnect the battery wiring harnesses (E).
6. Remove any square guide or bracket fastening the batteries (E).
7. Check that WET battery caps (J) are closed, to prevent the highly corrosive acid from leaking out of the batteries.
8. With the help of an assistant and an appropriate hoisting system, remove the batteries (E).

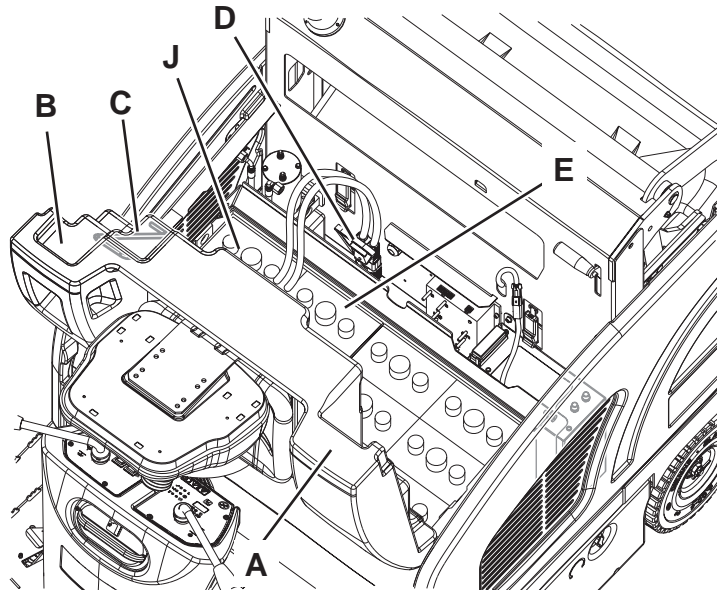

Battery Voltage Check (SW4000 Petrol)

1. Drive the machine on a level floor.
2. Turn on the machine and engage the parking brake.
3. Open the engine compartment hood with the handle and fasten it with the support rod.
4. Check the voltage at the battery pins.
5. With the accessories turned off and the engine running, the voltage must be between 27 V and 31 V.
6. If the voltage is lower, check the diode electronic board (EBD) and battery operation. If necessary, charge the batteries with a battery charger suitable for cars (slow charging).

Fuse Check/Replacement (SW4000 Battery)

7. Drive the machine on a level floor.
8. Turn the ignition key to “0” and engage the parking brake.
9. Open the battery/engine compartment hood with the handle and fasten it with the support rod. Disconnect the battery connector.

Lamellar Fuse Check/Replacement

10. On the electrical component box, remove the fuse box cover (A).
11. Check/replace the relevant fuse among the following:
 - (B): F1 vacuum system motor fuse (25 A).
 - (C): F2 filter shaker motor fuse (25 A).
 - (D): F3 display electronic board fuse (3 A).
 - (E): F4 main fuse (key circuit) (10 A).
 - (F): F5 dust guard system fuse (5 A).
 - (G): F6 hopper lifting fuse (25 A).
12. Reinstall the fuse box cover (A).
13. Remove the screws (H), then remove the electrical component box cover (I).

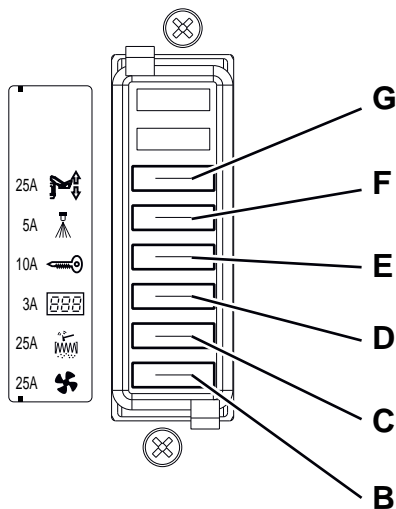

14. Check/replace the following fuses:
 - (J): FA main broom motor fuse (50 A).
 - (K): F0 main fuse (150 A).
15. Place the cover (I) and tighten screws.

Fuse Check

16. Check one of the following fuses for deactivation:
 - (L): FR1 right side broom motor fuse (15 A)
 - (M): FR2 left side broom motor fuse (15 A)

Reset any deactivated fuse, when the component that caused deactivation has fully cooled down.

Reassembly

17. Connect the batteries.
18. Remove the support rod and close the battery/engine hood.

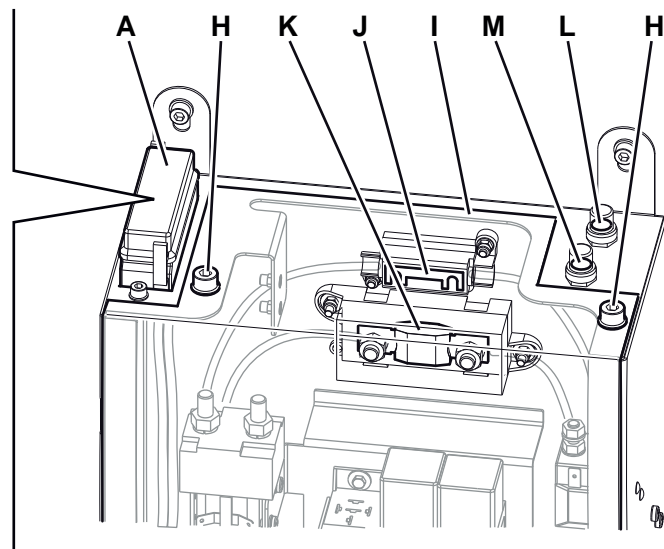

Fuse Check/Replacement (SW4000 Petrol/LPG)

1. Drive the machine on a level floor.
2. Turn the ignition key to “0” and engage the parking brake.
3. Open the battery/engine compartment hood with the handle and fasten it with the support rod. Disconnect the batteries.
8. Check/replace the following fuses:
 - (J): FA main broom motor fuse (50 A).
 - (K): F0 main fuse (150 A).
 - (L): FC battery fuse (80 A)
9. Place the cover (I) and tighten screws.

Lamellar Fuse Check/Replacement

4. On the electrical component box, remove the fuse box cover (A).
5. Check/replace the relevant fuse among the following:
 - (B): F1 vacuum system motor fuse (30 A).
 - (C): F2 filter shaker motor fuse (30 A).
 - (D): F3 display electronic board fuse (3 A).
 - (E): F4 main fuse (key circuit) (10 A).
 - (F): F5 dust guard system fuse (5 A).
 - (G): F6 hopper lifting fuse (30 A).
6. Reinstall the fuse box cover (A).
7. Remove the screws (H), then remove the electrical component box cover (I).

Fuse Check

10. Check one of the following fuses for deactivation:
 - (M): FR1 right side broom motor fuse (15 A)
 - (N): FR2 left side broom motor fuse (15 A)

Reset any deactivated fuse, when the component that caused deactivation has fully cooled down.

Reassembly

11. Connect the batteries.
12. Remove the support rod and close the battery/engine hood.

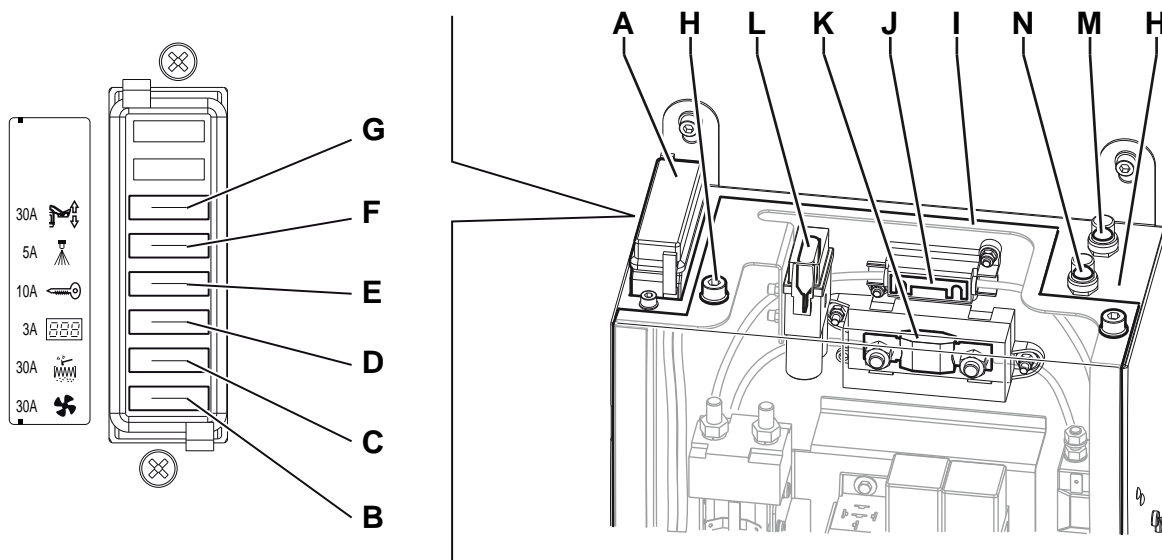

Troubleshooting

Trouble	Possible causes	Remedy
The machine is not working	The batteries are discharged or its connections are not efficient	Charge the batteries or clean/repair the connections
	The batteries are broken	Check the battery no-load voltage
	(SW4000 Battery) The battery charger is broken	Replace
	(SW4000 Petrol/LPG) The dynamotor is broken	Repair
	The fuses are open	Replace
	The wiring harness is cut or pressed or short circuited	Repair
	The ignition key is not working	Replace

Removal and Installation

Battery Charger Disassembly/Assembly (SW4000 Battery)

Disassembly

1. Drive the machine on a level floor.
2. Turn the ignition key to “0” and engage the parking brake.
3. Open the battery compartment hood with the handle and fasten it with the support rod. Disconnect the battery connector.
4. Remove the screws (A) and the battery charger connector (B).
5. Remove the screws (C) on the rear side of the bulkhead, then remove the battery charger protection (D).
6. Remove the screws with the nut (E) and remove the battery charger (F) with the wiring harness (G).

Assembly

7. Assemble the components in the reverse order of disassembly, and note the following:
 - The selector (H) must be turned to WET or GEL, according to the type of batteries (WET or GEL) installed on the machine.

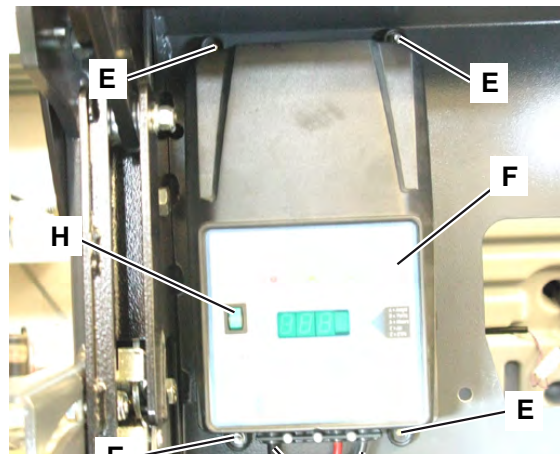
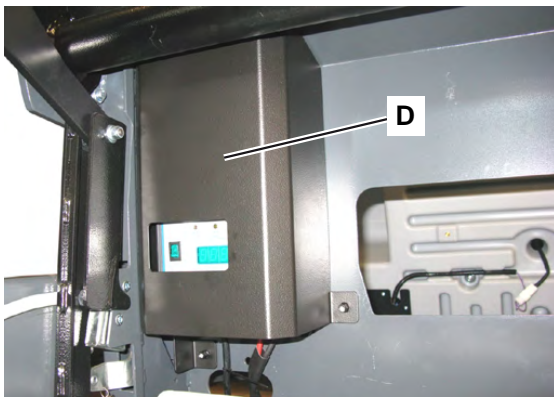
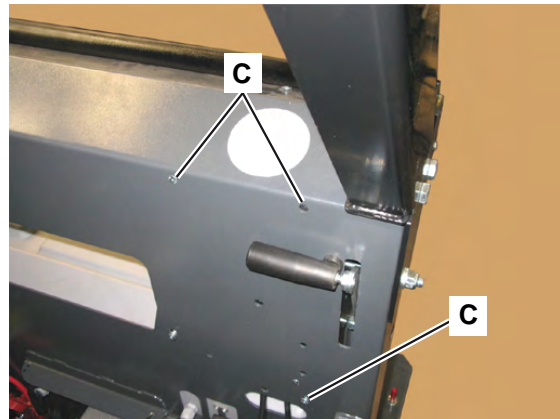
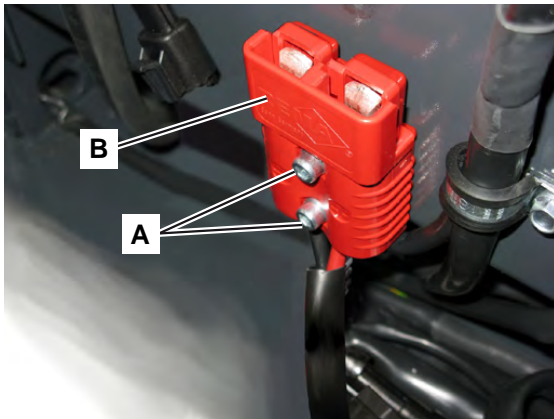

Dynamotor Carbon Brush Check/Replacement (SW4000 Petrol)

Disassembly

1. Drive the machine on a level floor.
2. Turn the ignition key to “0” and engage the parking brake.
3. Open the engine compartment hood with the handle and fasten it with the support rod. Disconnect the batteries.
4. Remove the machine right side bulkhead, by lifting it to disengage it from the fasteners.
5. Remove the two screws (A) and remove the case (B).
6. If necessary, clean the external side of the dynamotor (C) in the area of the protection band (D).
7. Disengage the cam lever (E) and remove the protection band (D) of the dynamotor (C).

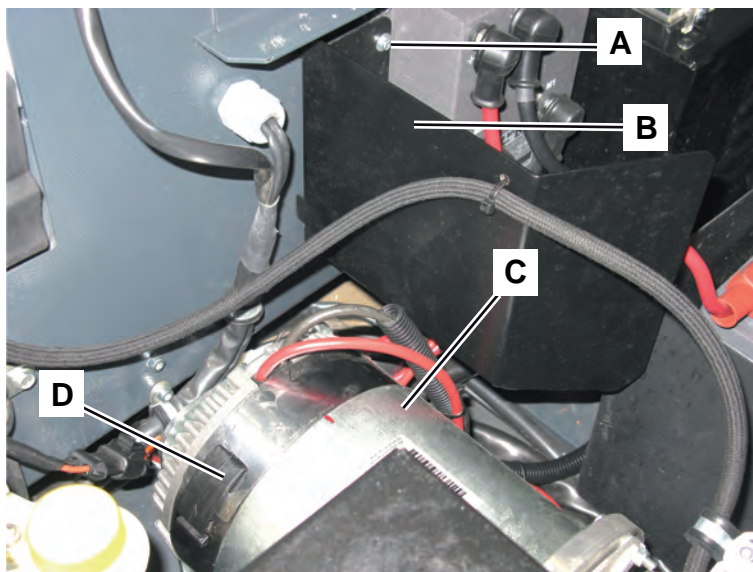

Dynamotor Carbon Brush Check/Replacement (SW4000 Petrol) (Continues)

8. Remove the fastening screws (G) of the electrical connections of the four carbon brushes (H).
9. Remove the four carbon brushes (H) from their housings, by disengaging them from the retaining springs (I).
10. Check the four carbon brushes (H) for wear. The carbon brushes are worn when:
 - The contact with the motor armature is insufficient
 - The contact surface is not integral
 - The stroke is less than 0.12 in (3 mm)
 - The spring is broken

In this cases, replace all all dynamotor carbon brushes.

Assembly

11. Assemble the components in the reverse order of disassembly.

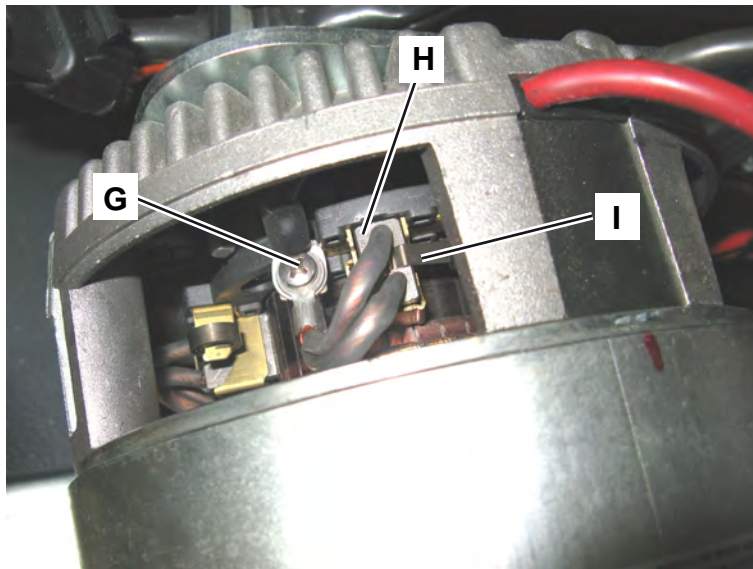

Dynamotor Disassembly/Assembly (SW4000 Petrol)

Disassembly

1. Remove the engine-dynamotor (see the procedure at the relevant paragraphs in Engine System, Petrol or Engine System, LPG).
2. Remove the dynamotor carbon brushes (refer to the procedure “Dynamotor Carbon Brushes Check/Replacement”).
3. Hold the crankshaft by operating the outer pulley in the area (B), loosen the lock nut (A) until it is flush with the end of the shaft.
4. Remove the two screws (C) with nuts (D) fastening the dynamotor (M) to the holder (E). Retrieve the washers.
5. Remove the four screws (F) with nuts (G) fastening the dynamotor to the engine. Retrieve the washers.
6. Remove the screw in the area (N), then remove the baffle plate (H).

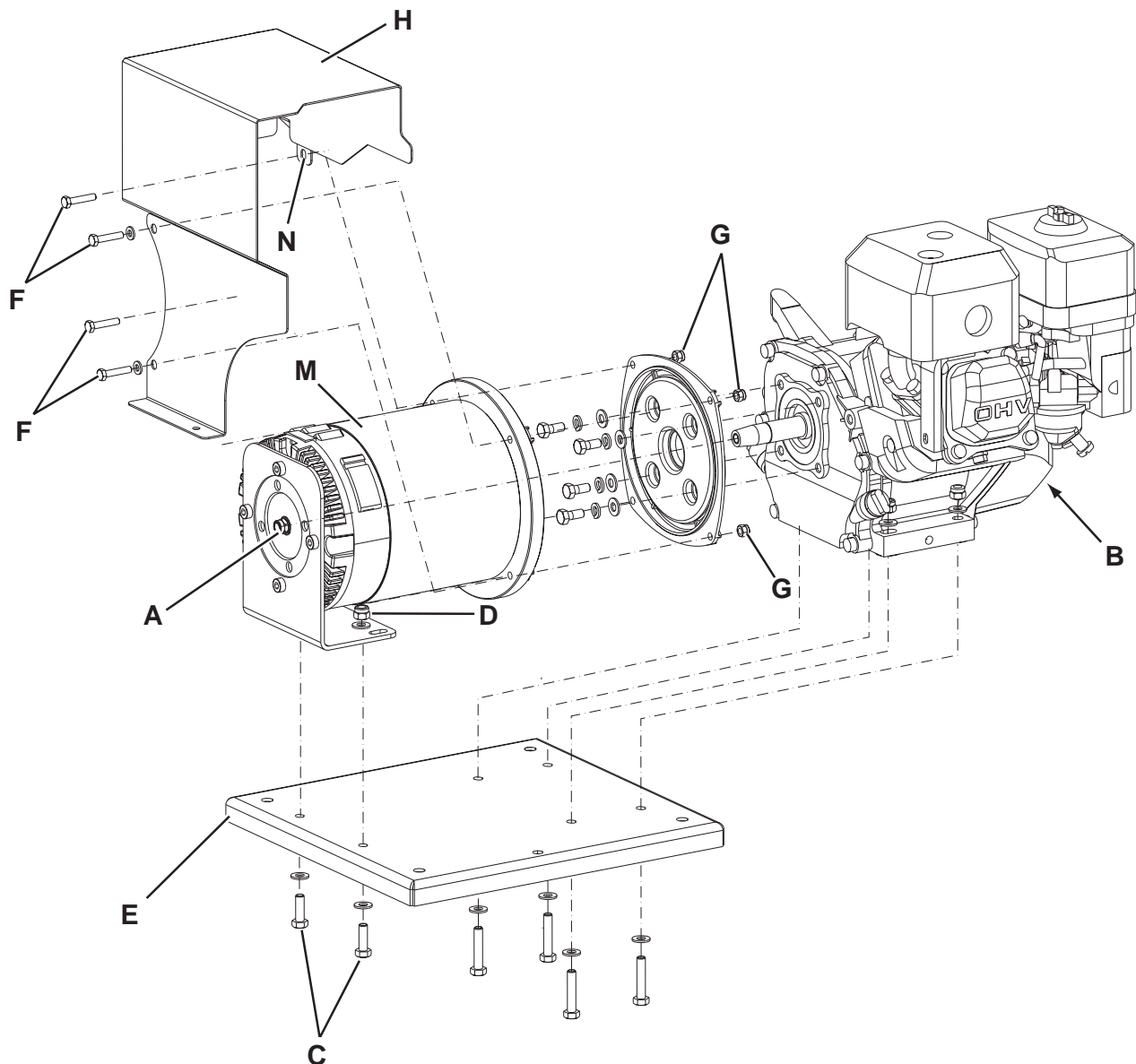

Dynamotor Disassembly/Assembly (SW4000 Petrol) (Continues)

7. Place a lever between the flange (I) of the dynamotor and the flange (J), then by means of the lever itself push the dynamotor in the direction of the arrow (K); in this condition, give a firm blow on the nut (A) in the direction of the arrow (L) with a plastic mallet, thereby disengaging the conical connection of union between dynamotor and the engine.
8. Loosen the nut (A) completely and remove the dynamotor (M) (Dynamotor weight: 17 kg approx).

Assembly

9. Assemble the components in the reverse order of disassembly, and note the following:
 - The self-locking nut (A) must be fully screwed down, without tightening it.

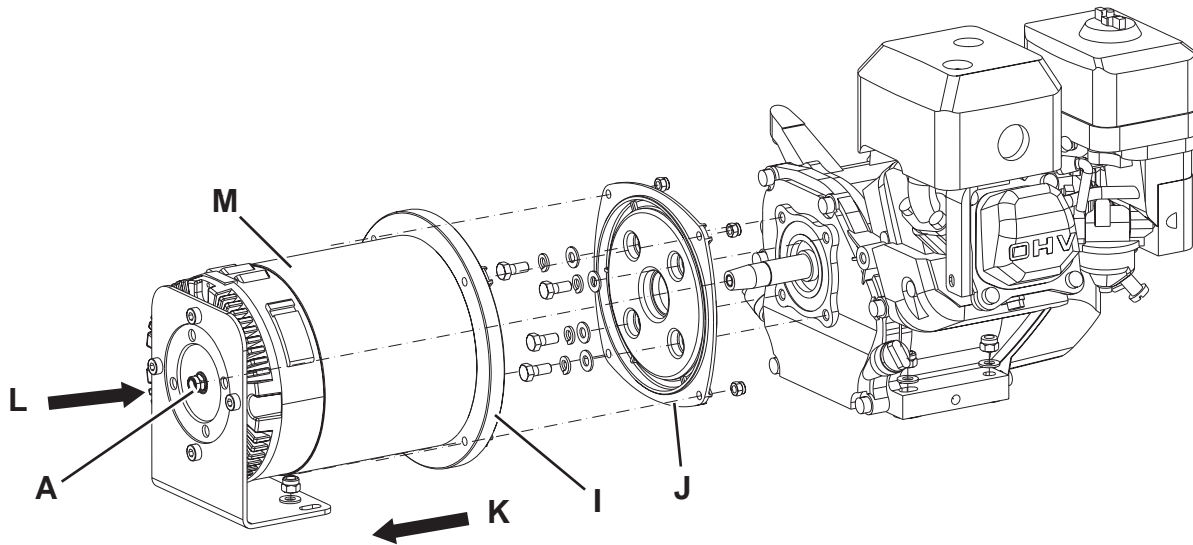

P200126

General Wiring Diagram (SW4000 Battery)

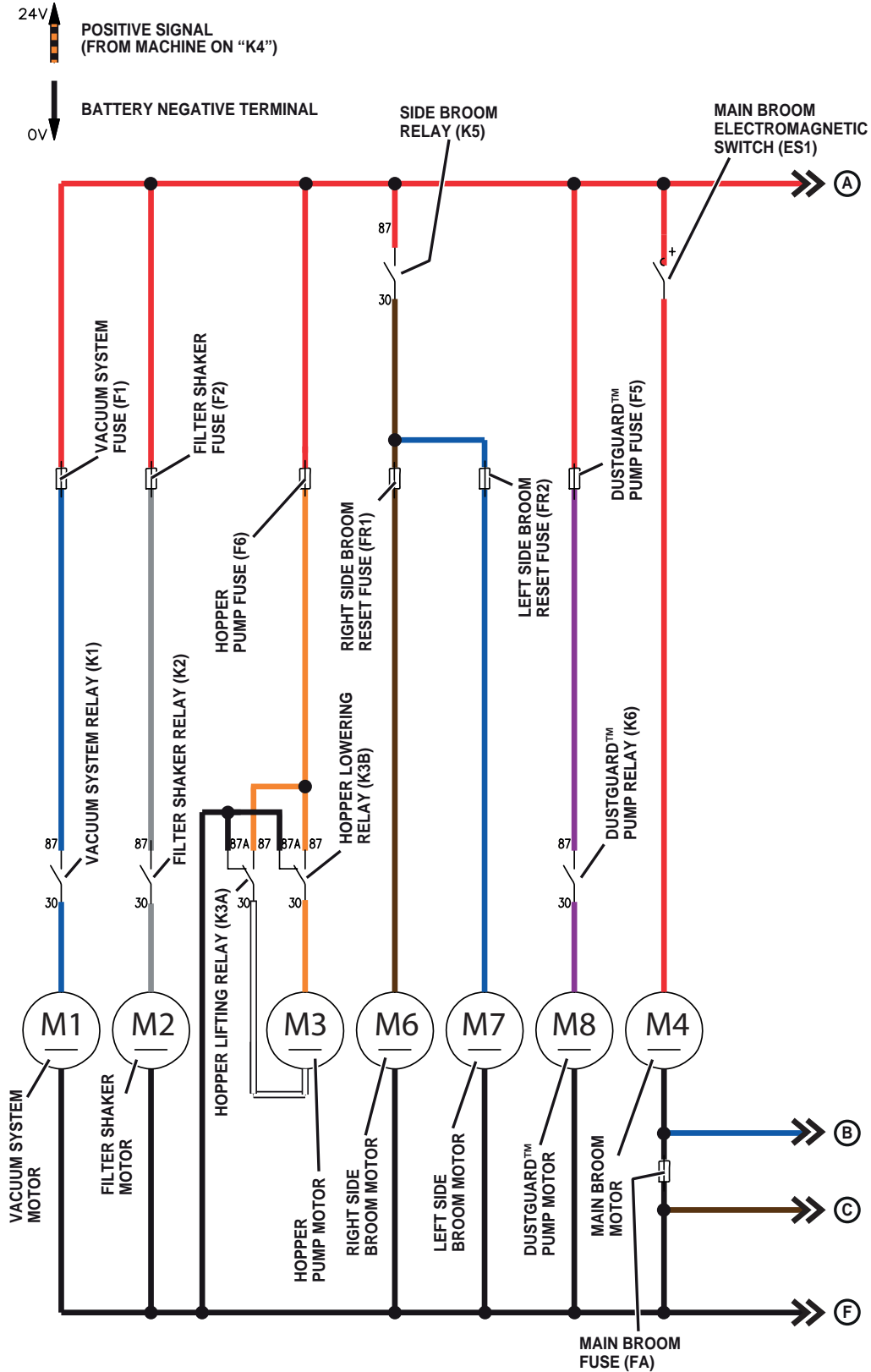

General Wiring Diagram (SW4000 Battery)

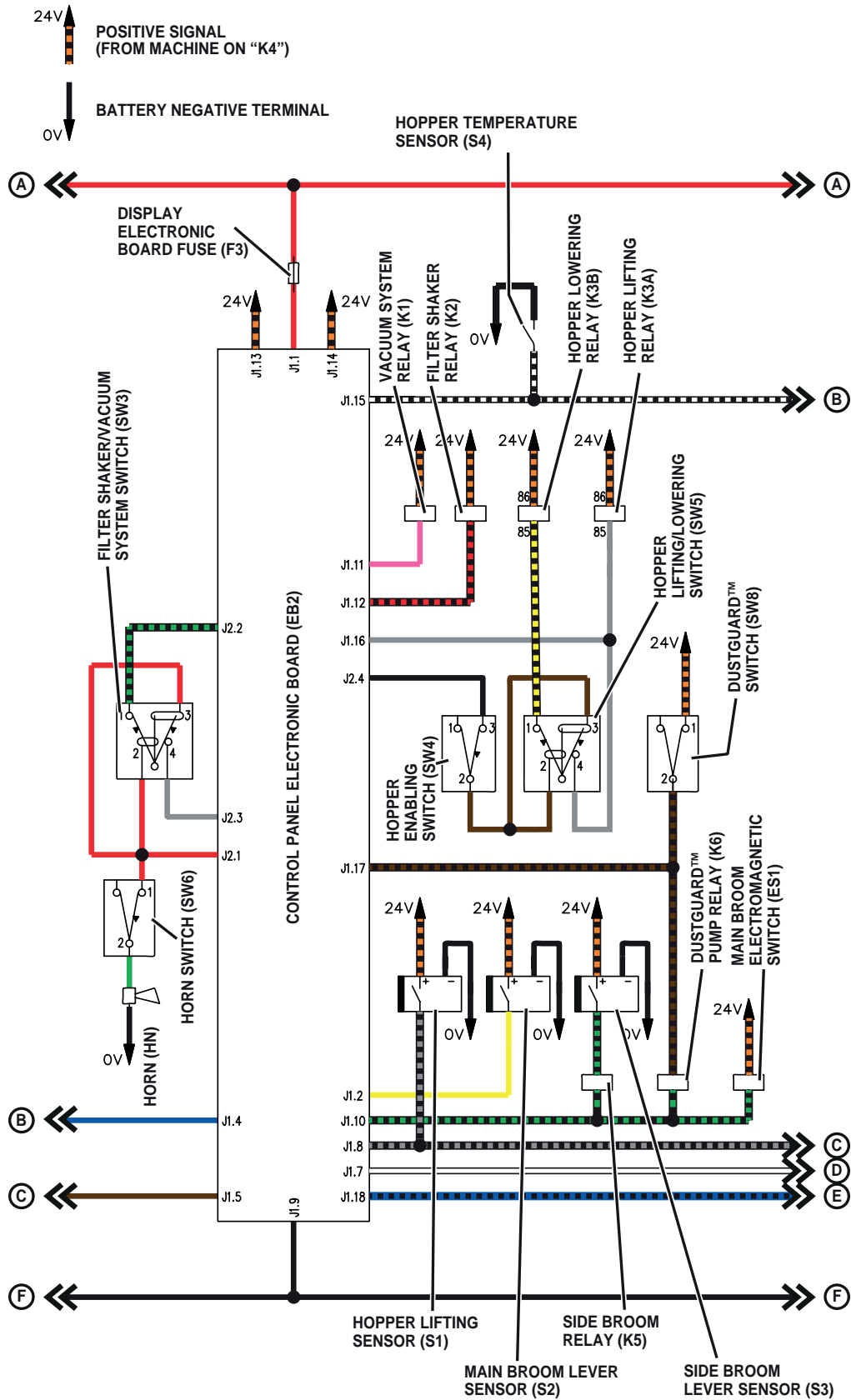

General Wiring Diagram (SW4000 Battery)

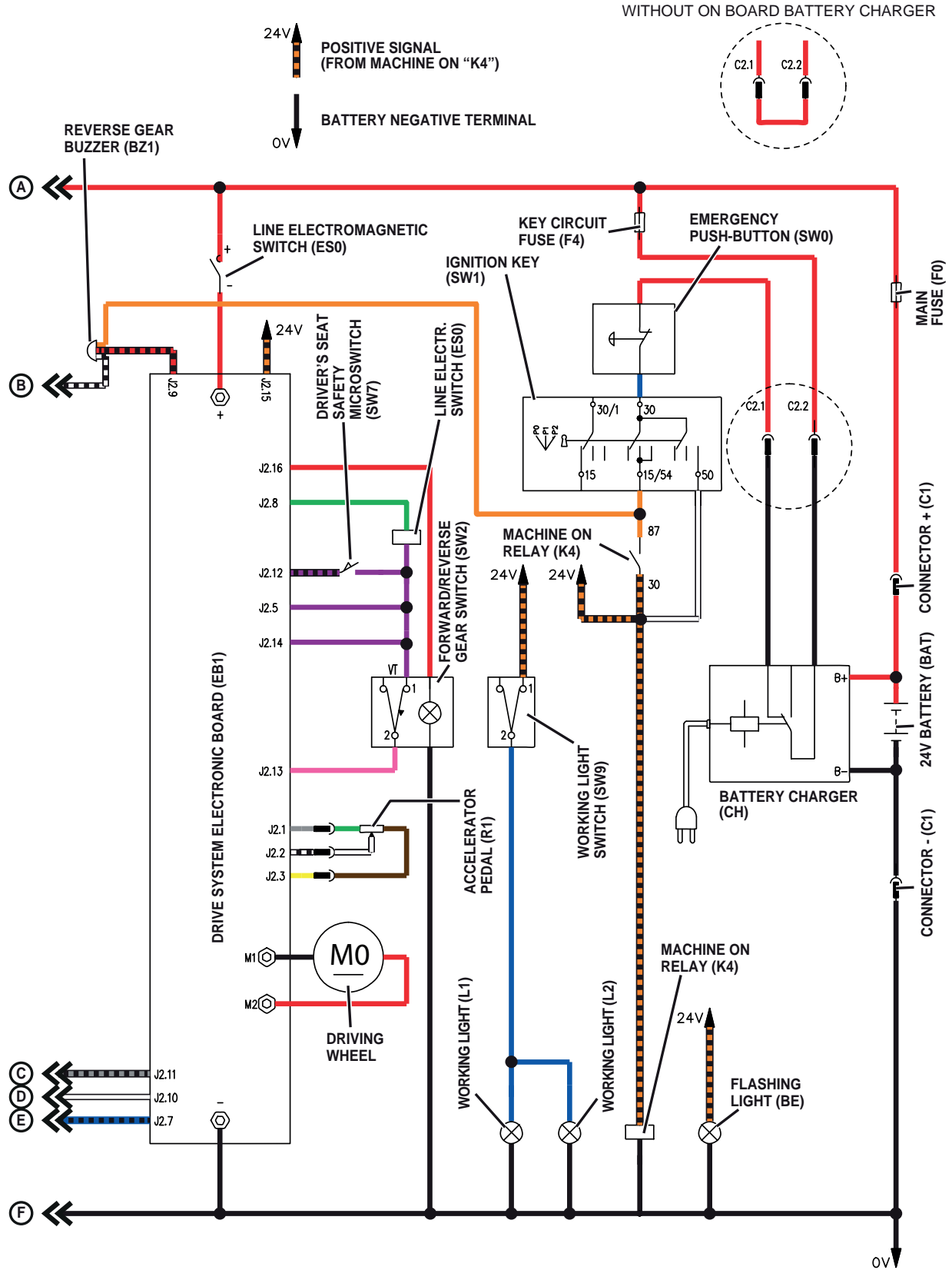

General Wiring Diagram (SW4000 Petrol - LPG)

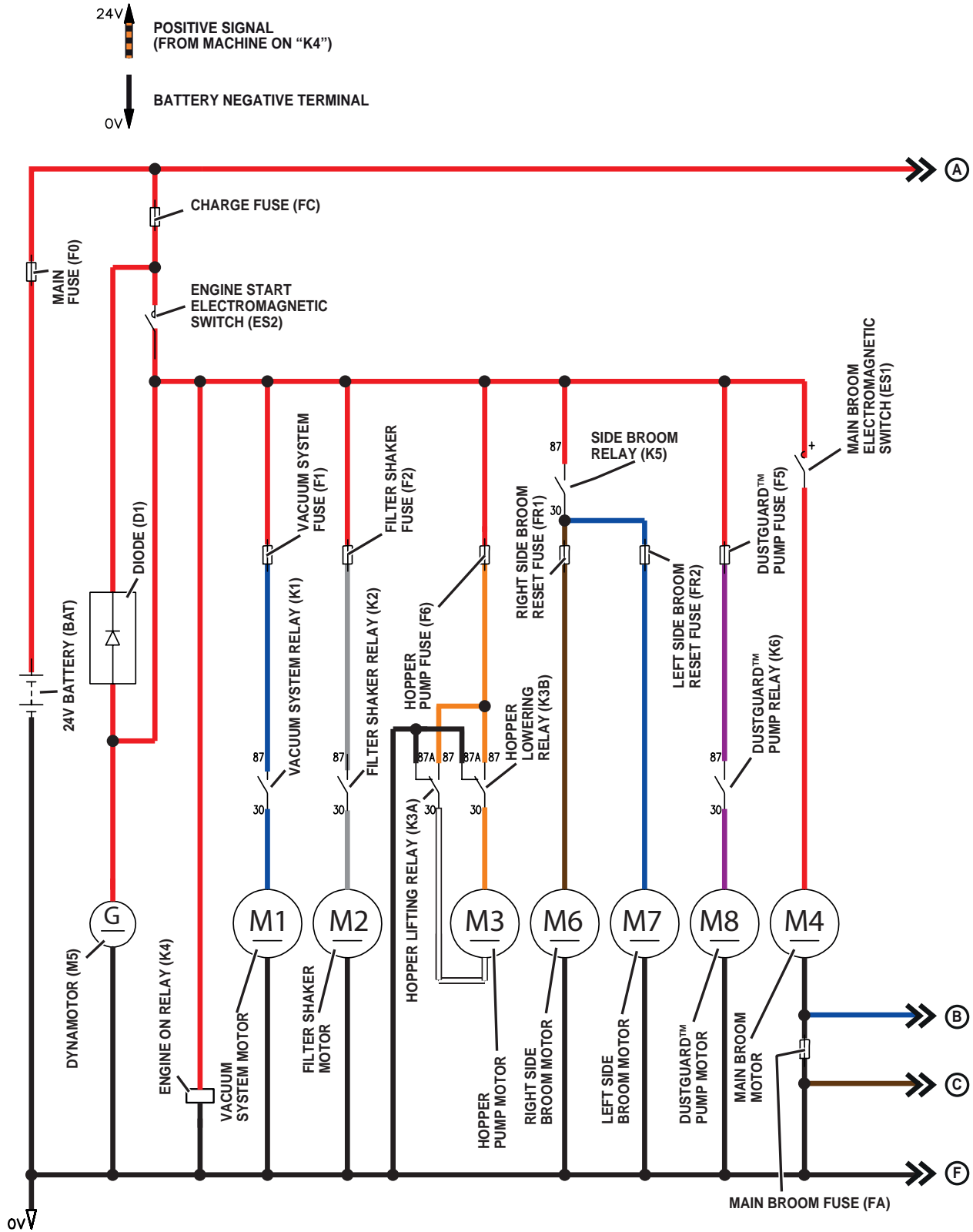

General Wiring Diagram (SW4000 Petrol - LPG)

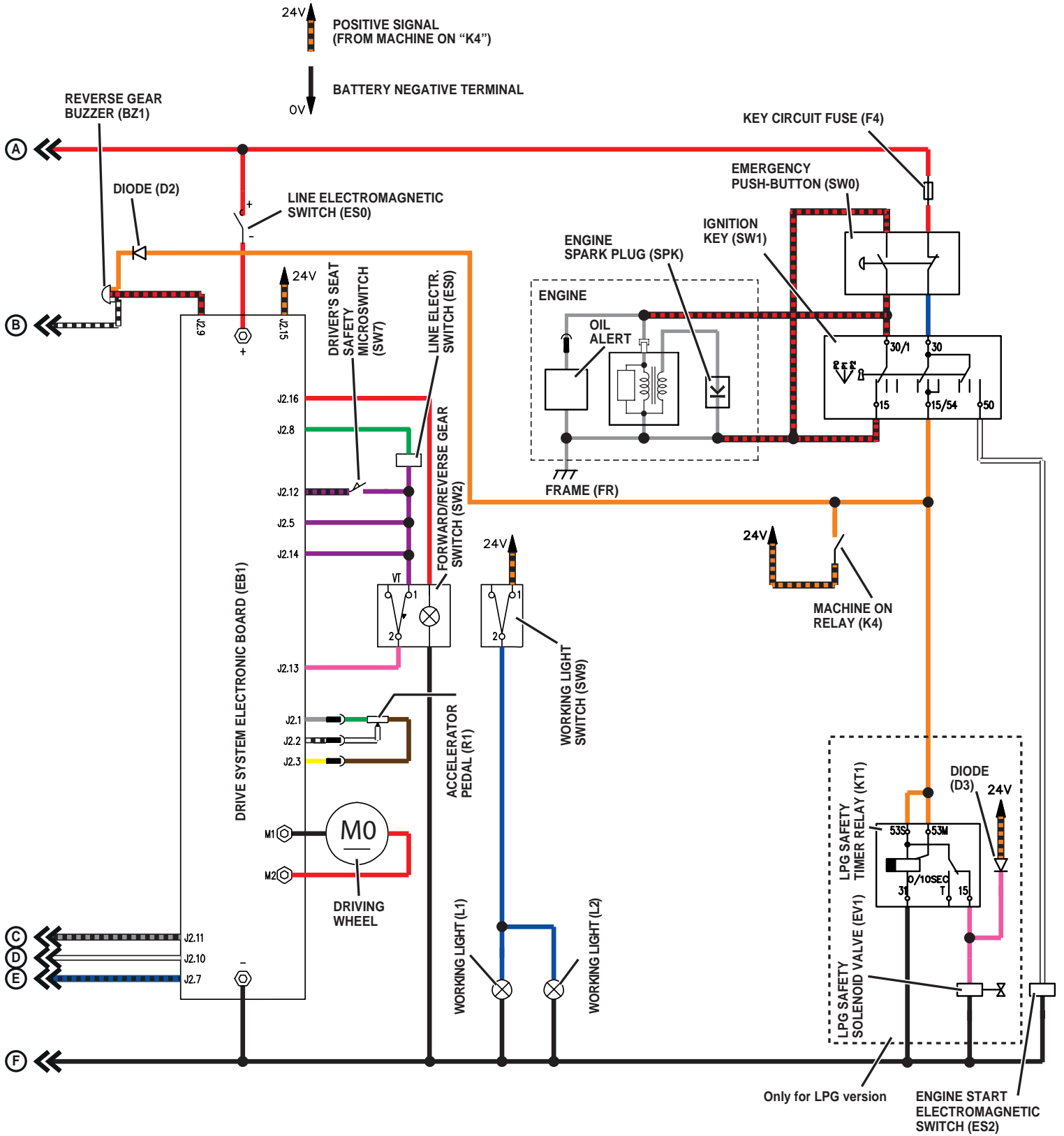

Specifications

Electrical components	Values		
	SW4000 Battery	SW4000 Petrol	SW4000 LPG
Total absorbed power	2.7 hp (2.0 kW)		

Batteries	Values
	SW4000 Battery
Battery pack 1	12 x 2V x 360A 6 EPzS 360 (WET)
Battery pack 2	12 x 2V x 360A 6 EPzV 330 (GEL-AGM)
Size (length x width x height)	32.0 x 14.8 x 15.4 in (812 x 375 x 390 mm)
Battery pack 3	12 x 2V x 330A 12-55L-13 330 (WET)
Battery pack 4	4 x 6V x 255A FF 06 255 (WET)
Battery pack 5	4 x 6V x 180A (GEL-AGM) DF 06V 180A
Size (length x width x height)	16.6 x 24.8 x 5.9 in (420 x 630 x 150 mm)
Battery compartment maximum size (width x length x height)	32.0 x 14.8 x 14.6 in (812 x 375 x 370 mm)

Battery charger	Values
	SW4000 Battery
Input	230V ± 15% 50/60Hz (Imax:15A)
Output	24V 30A
Efficiency	>90%
Min. Vbatt	2V
Casing protection	IP30

Batteries	Values	
	SW4000 Petrol	SW4000 LPG
Battery pack	2 x 12V 77Ah	
Size (length x width x height)	15.0 x 14.2 x 8.9 in (380 x 360 x 225 mm)	

Electrical components	Values		
	SW4000 Battery	SW4000 Petrol	SW4000 LPG
Dynamotor	-	1,400 W - 24V (70A - 1,600 rpm)	

Engine System - Petrol

Functional Description

The engine system generates electric current for all machine functions.

The assembly consists of an internal combustion engine and dynamotor, which are both connected to the main crankshaft.

The engine is a single-cylinder air-cooled petrol type. The engine start-up is made by the dynamotor to which it is connected.

The dynamotor acts as a starter, using the battery only for the time necessary to start the engine.

At a later stage, the running engine supplies the power to the dynamotor to generate the current and to power the electrical systems of the machine. The surplus current is used to charge the batteries.

The engine speed is fixed, 2,750 rpm, to grant a constant current to the electrical system.

The fuel tank is fastened outside the engine, in the rear side of the machine. The tank has a fuel level indicator with float, and a valve with integrated filter.

The choke lever on the engine has been extended in order to be easily activated from the driver's seat position.

The fuel reserve warning light turns on when the fuel in the tank is less than 2.2 liters.

The engine is equipped with an oil level sensor (Oil Alert), which purpose is to avoid damages caused by an insufficient oil quantity in the oil pan. Before the oil level goes below the safety limit, the system (Oil Alert) automatically stops the engine shorting the spark plug to the chassis..

If the engine stops and do not restart, check the engine oil level before doing any other troubleshooting procedure.

Wiring Diagram

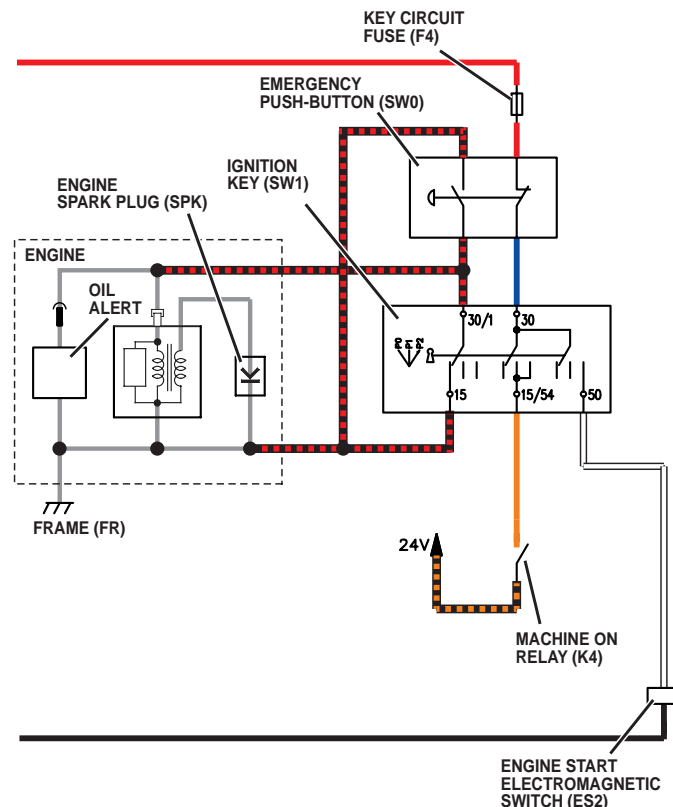

Component Locations

- Petrol engine
- Filler neck
- Fuel tank
- Fuel opening/closing valve
- Reserve sensor (S5)
- Diode (S1)
- Oil Alert Sensor

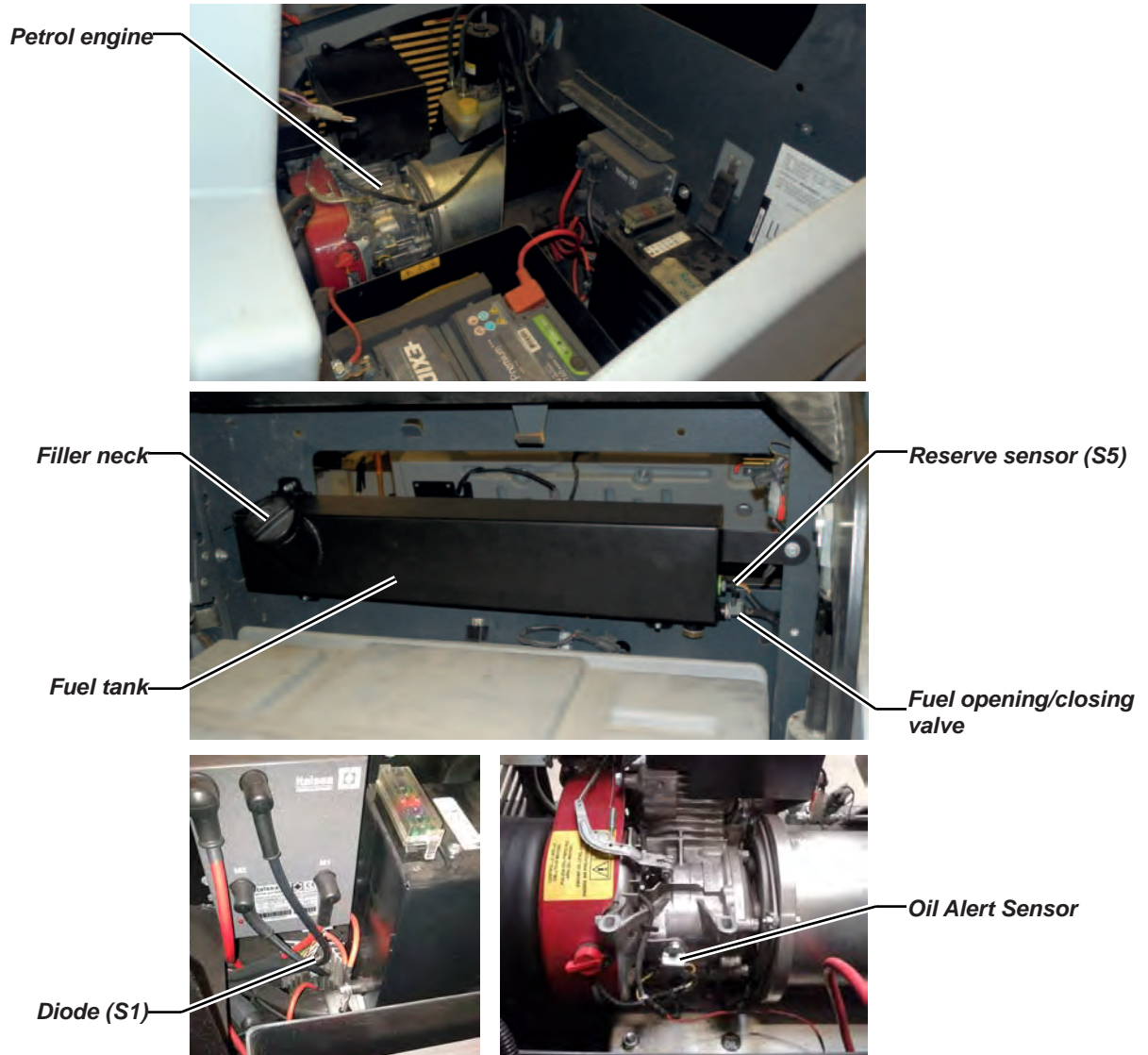

Maintenance and Adjustments

Engine RPM Check

1. To check the engine speed, use the indicator (A) fastened to the engine pulley, with a rev counter light (B) which can be seen from the front outer side of the engine compartment.
2. Alternatively use a rev counter (C) to be applied to the spark plug wire (D).

For the engine rpm, see Specifications paragraph.

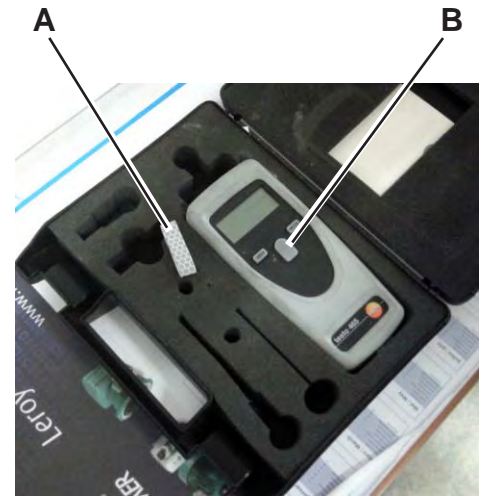
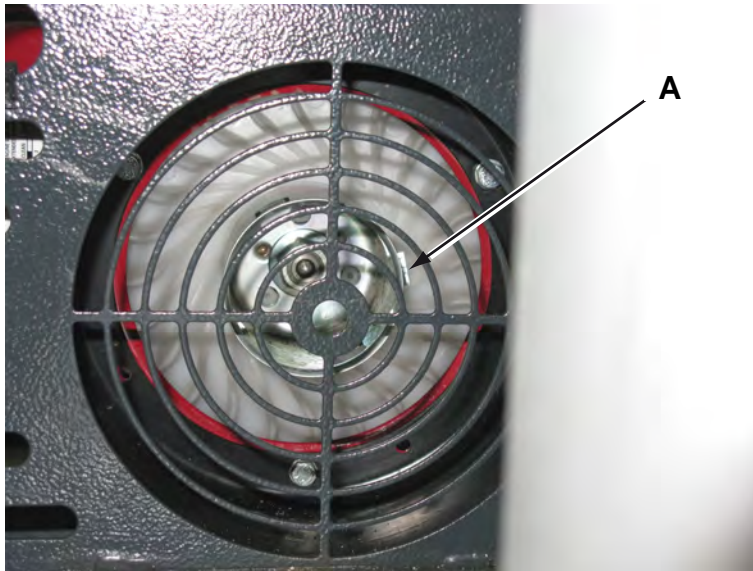

Engine Air Filter Cleaning Check



Caution! *Running the engine without air filters, or with damaged filters, can cause a faster engine wearing.*

1. Drive the machine on a level ground and engage the parking brake.
2. Turn the ignition key to “0”.
3. Open the engine compartment hood with the handle and fasten it with the support rod.
4. Lift and disassemble the right side bulkhead.
5. Remove the wing nut (A) and remove the cover (B).
6. Remove the wing nut (C) and disassemble the filter element.
7. Separate the foam filter (D) from the paper filter (E).
8. Check both filters and replace them if necessary. Replace the paper filter (D) when required (see the scheduled maintenance table).
9. To use again the filters, clean them as shown below:
 - Paper filter (E): Hit the filter several times against a hard surface to remove the dust, or blow compressed air (no more than 207 kPa (2.1 kgf/cm)) from inside the filter. Do not use a brush, otherwise the fibre will be damaged.
 - Foam filter (D): Clean with warm water and soap, rinse and let it dry completely, or clean with a non-flammable solvent and let it dry. Soak the filter in clean engine oil, then squeeze it to remove the surplus oil.
10. Clean with a wet cloth the base (F) and the cover (B) of the air filter. Pay attention to avoid that dirt enters the air duct (G) to the carburettor.
11. Assemble the foam filter (D) on the paper filter (E), then assemble the filter element. Ensure that the gasket (H) is properly placed under the filter element. Screw down the filter element wing nut (C).
12. Install the cover (B) and screw down the wing nut (A).
13. Perform steps 4 and 3 in the reverse order.

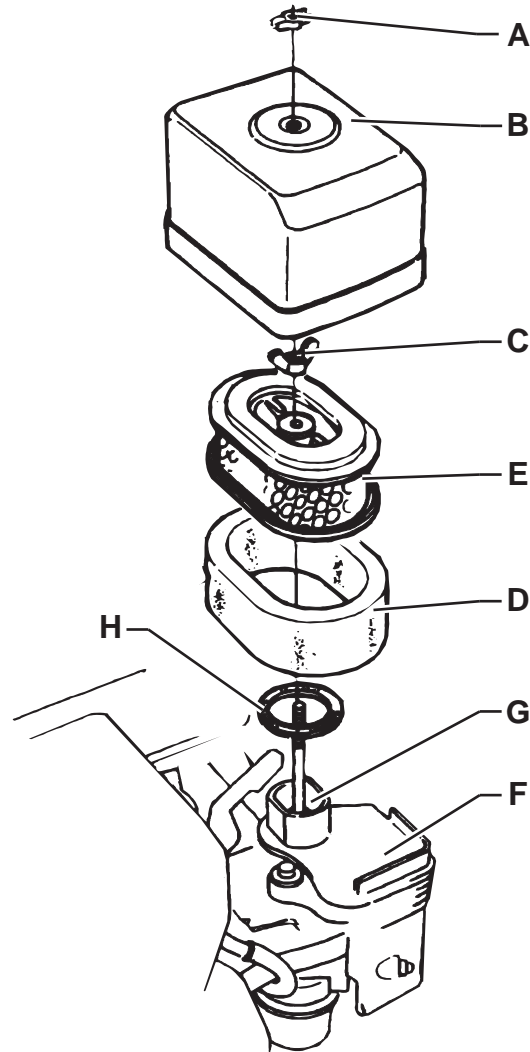

Engine Oil Level Check



Caution! *Running the engine with a low oil level can damage the engine itself.*



Note: *The oil alert system will automatically stop the engine before the oil level goes down under the safety limit. To avoid a sudden engine stop, always check the oil level before each start-up.*

1. Drive the machine on a level ground and engage the parking brake.
2. Turn the ignition key to “0”.
3. Open the engine compartment hood with the handle and fasten it with the support rod.
4. Lift and disassemble the right side bulkhead.
5. Remove the oil filler plug/dipstick (A) and clean it.
6. Insert the oil filler plug/dipstick in the filler neck (B), but do not tighten it, then remove it to check the oil level.
7. If the oil level is near or under the lower limit mark (C) on the dipstick, top up with the specified oil up to the upper limit mark (D) (lower edge of the oil filling hose). Do not overfill.
8. Install the oil filler plug/dipstick (A).
9. Perform steps 4 and 3 in the reverse order.

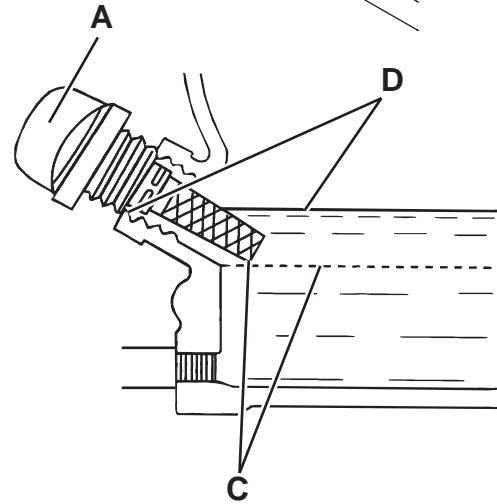
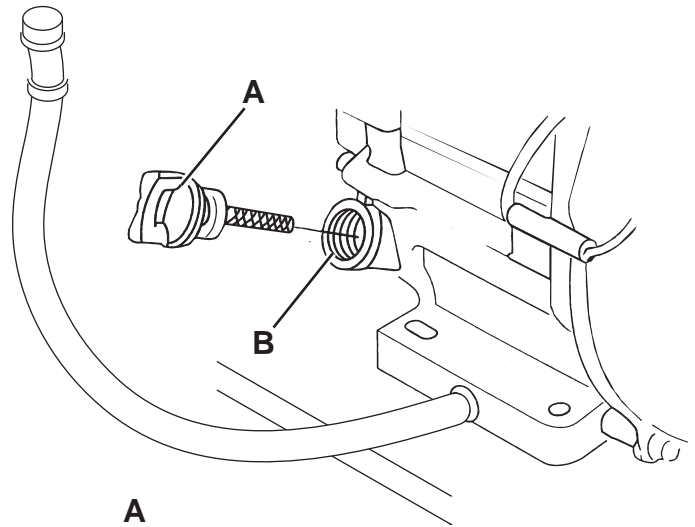

Engine Oil Change



Caution! *The discharged engine oil must be disposed of properly according to the Law in force.*



Note: *It is advisable to change the oil when the engine is still hot, to make the oil downflow easier.*

1. Drive the machine on a level ground and engage the parking brake.
2. Turn the ignition key to “0”.
3. Open the engine compartment hood with the handle and fasten it with the support rod.
4. Lift and disassemble the right side bulkhead.
5. Remove the oil filler plug/dipstick (A). Place the hose (E) in a position that eases the oil drain, then remove the plug (F).
6. Drain all the engine oil through the hose (E) and collect it in a proper container.
7. Install the oil drain plug (F) and place the hose (E) back to the original position.
8. Pour new oil in the filler neck (B) up to the upper limit mark (D) (lower edge of the oil filling hose) on the dipstick.



Note: *For the engine oil type and quantity, see Specifications paragraph.*

9. Install the oil filler plug/dipstick (A) and tighten it.
10. Perform steps 4 and 3 in the reverse order.

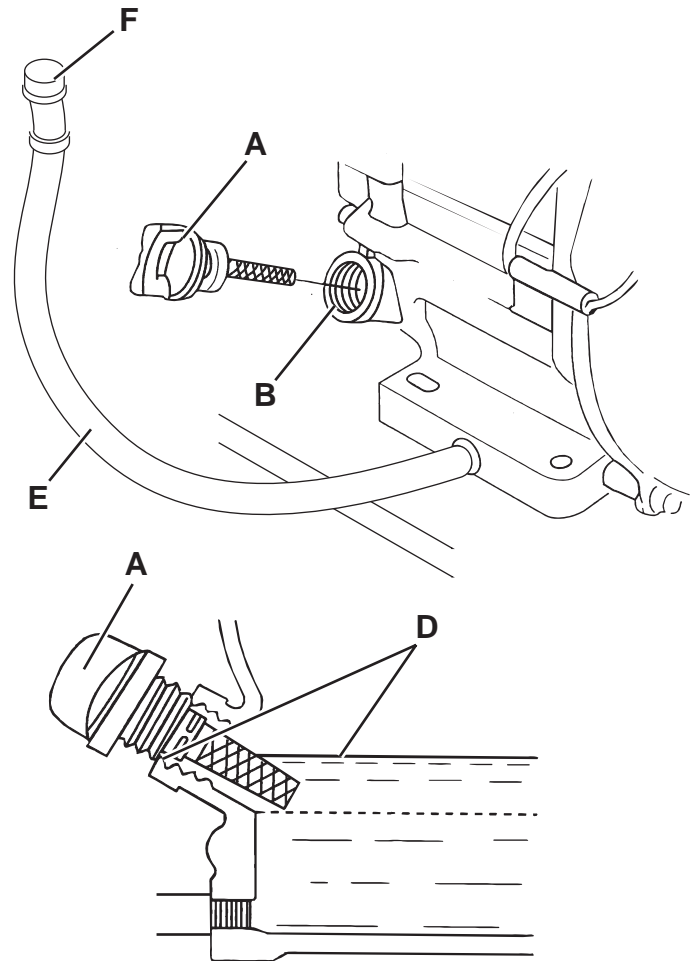

P200133

Engine Filter Trap Cleaning



Warning! *The petrol is highly flammable and explosive, it can burn or cause serious injuries. Turn off the engine, and keep it far from sparks, flames and other sources of heat. Handle the fuel outdoors only. Wipe immediately any fuel accidentally spilled out.*

1. Drive the machine on a level ground and engage the parking brake.
2. Turn the ignition key to “0”.
3. Open the engine compartment hood with the handle and fasten it with the support rod.
4. Lift and disassemble the right side bulkhead.
5. Move the fuel lever (A) to OFF, then remove the fuel filter cup (B) and the O-ring (C).
6. Wash the fuel filter trap (B) and the O-ring (C) with a non-flammable solvent, then dry them accurately.
7. Place the O-ring (C) and assemble the filter cup (B) by tightening it securely.
8. Move the fuel lever (A) to ON and check for leakages. If any leakage is found, replace the O-ring (C).
9. Perform steps 4 and 3 in the reverse order.

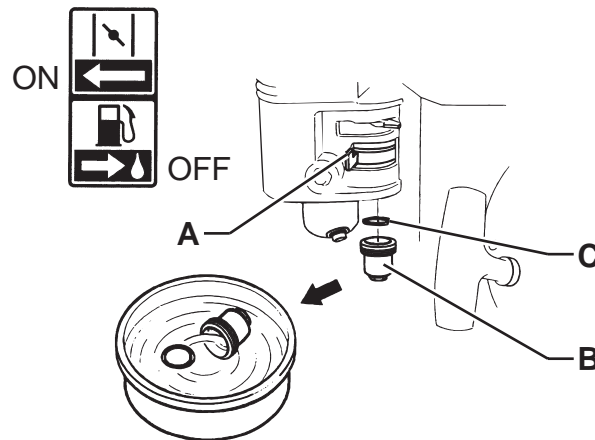

Engine Spark Plug Check/Replacement

For the type of spark plug to be used, see Technical Data chapter.



Warning! A wrong spark plug can damage the engine.

1. Drive the machine on a level ground and engage the parking brake.
2. Turn the ignition key to “0”.
3. Open the engine compartment hood with the handle and fasten it with the support rod.
4. Lift and disassemble the right side bulkhead.
5. Disconnect the spark plug cap and remove dirt around the spark plug.
6. Remove the spark plug with a proper wrench (A).
7. Check the spark plug. Replace it if it is damaged, dirty, if the sealing washer (B) is damaged or if the electrode is worn.
8. Measure the distance between the spark plug electrodes with a feeler gauge. Correct the distance by bending carefully the side electrode (C). The distance between the electrodes must be of 0.70 - 0.80 mm.
9. Install the spark plug manually with great care, to avoid tightening it improperly.
10. Once the spark plug is in place, tighten it with a proper wrench to press the sealing washer.
11. When a new spark plug is installed, tighten 1/2 turn once the spark plug is in place to press the washer.



Note: A loose spark plug can overheat and damage the engine. Do not overtighten, otherwise the threads in the cylinder head can be damaged.

12. When the original spark plug is reinstalled, tighten 1/8 - 1/4 turn once the spark plug is in place to press the washer.
13. Perform steps 4 and 3 in the reverse order.

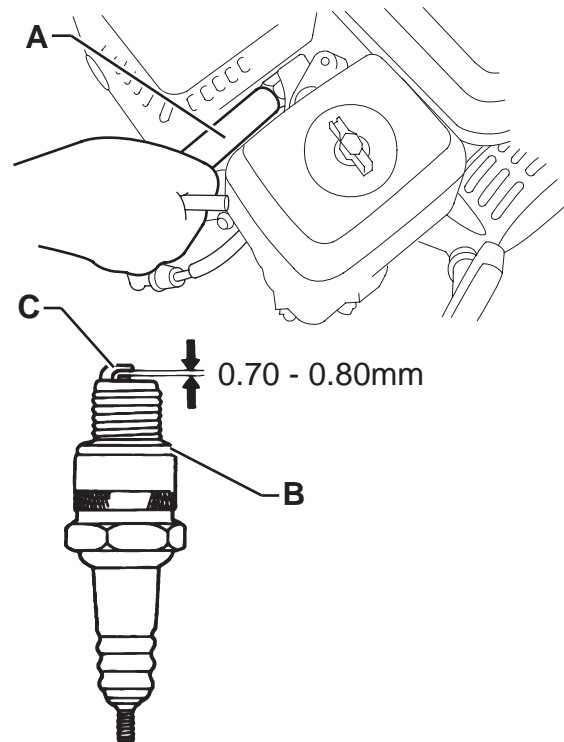

P200135

Engine Baffle Plate Cleaning



Warning! *If the engine was running, the silencer will be very hot. Let it cool down before operating on the baffle plate.*

1. Drive the machine on a level ground and engage the parking brake.
2. Turn the ignition key to “0”.
3. Open the engine compartment hood with the handle and fasten it with the support rod.
4. Lift and disassemble the right side bulkhead.
5. Remove the screws (A) and carefully remove silencer guard (B).
6. Remove the screws (C) and remove the exhaust manifold (D).
7. Remove the screws (E) and carefully remove silencer guard (F).
8. Remove the screw (G) and remove the baffle plate (H) from the silencer.
9. Use a brush to remove the carbon deposits from the baffle plate shield (I). Take care not to cause damage to the shield. Replace the baffle plate if it cracked or perforated.
10. Install the baffle plate (H), the silencer guard (F) and the exhaust manifold (D).
11. Assemble the components in the reverse order of disassembly.

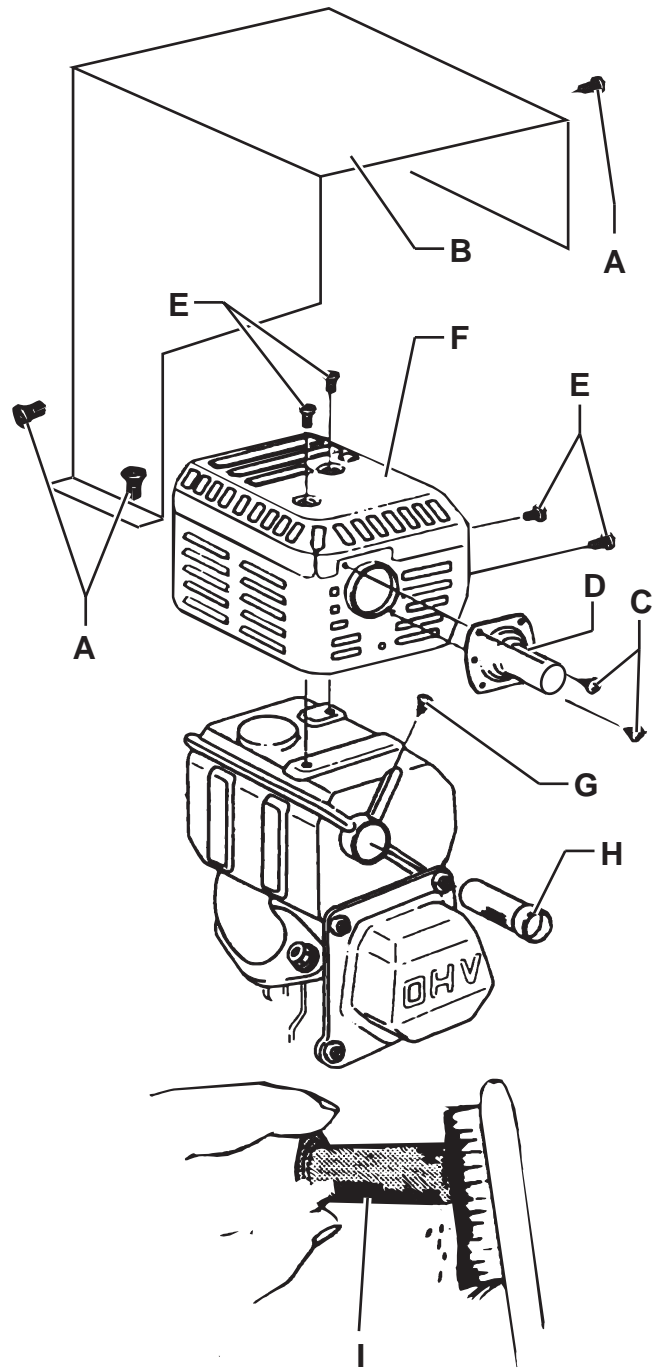

Troubleshooting

Trouble	Possible causes	Remedy
The engine does not start	The fuel valve lever is closed	Open the fuel lever
	The air control is in standard position.	Turn the lever to cold start position.
	The oil level is low. The Oil Alert sensor is activated.	Top up with the recommended oil to the proper level.
	The spark plug (SPK) is damaged, dirty or the distance between the electrodes is wrong	Correct the distance between the electrodes and replace the spark plug
	The spark plug (SPK) is wetted with fuel	Dry the spark plug and reinstall it. Start the engine with the choke lever turned to MAX position.
	The spark plug (SPK) does not produce a spark.	Check or replace the spark plug.
	The fuse (F3) and/or (F0) is open.	Check/replace the fuses.
	The electromagnetic switch (ES2) is faulty	Replace
	The batteries are discharged.	Recharge with a proper battery charger.
	The emergency push-button has been pressed.	Check and release the emergency push-button.
The engine loses power or stops during operation.	The filter element or elements are clogged	Clean or replace the filter elements
	Low quality of the fuel	Drain the tank and refuel with fresh petrol
	The fuel filter is clogged, the carburettor is broken, the start system is broken, the valves are locked, etc.	Replace or repair the faulty components as necessary (take the engine to an authorized Honda service centre)
The display shows the LOU code.	The working conditions are disadvantageous for the batteries.	Decrease the main broom pressure on the floor.
		Avoid driving uphill for long.
		Turn off the working lights.
		If the problem persist, maybe it is necessary to calibrate the engine rpm.
The display shows the HIU code.	The battery charge is excessive.	Turn off the engine each time the machine is stopped.
		If the problem persist, maybe it is necessary to calibrate the engine rpm.

Removal and Installation

Engine-Dynamotor Unit Disassembly/Assembly

Disassembly

1. Drive the machine on a level floor.
2. Turn the ignition key to “0” and engage the parking brake.
3. Open the engine compartment hood with the handle and fasten it with the support rod. Disconnect the batteries.
4. Remove the machine right side bulkhead (A), by lifting it to disengage it from the fasteners.
5. Close the fuel valve (B).
6. Open the clamp (C) and disconnect the fuel hose (D) from the valve. Close with sealing plugs the disconnected fittings to prevent foreign materials from entering into the system.
7. Open the clamp (E) fastening the fuel hose (D).

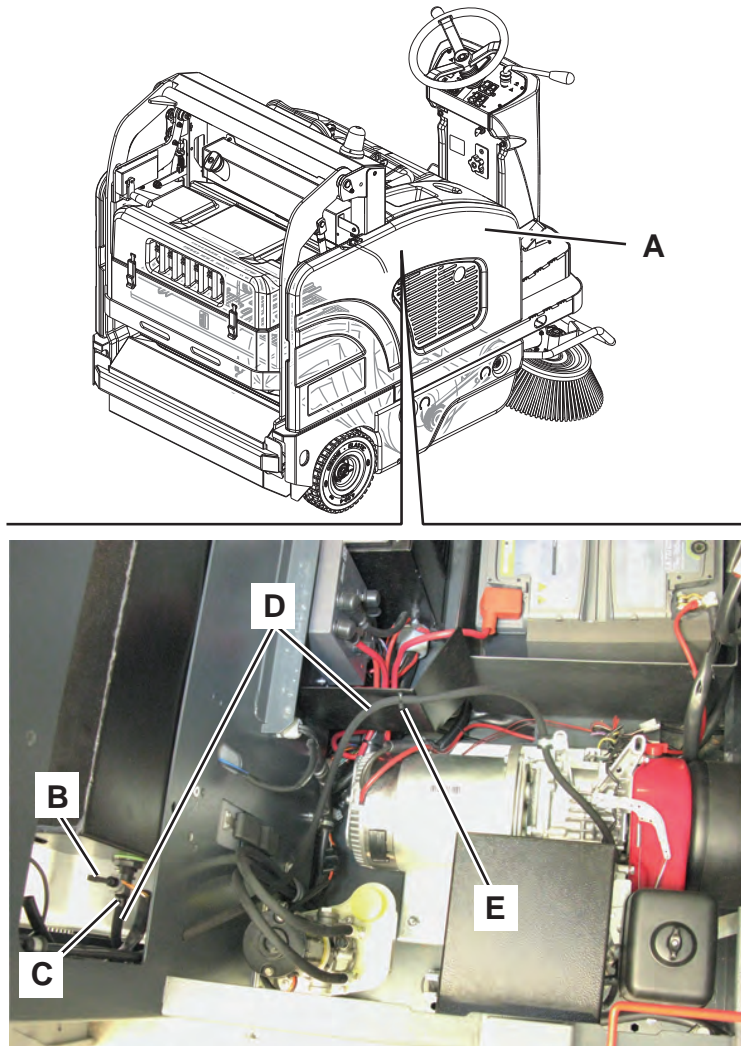

Engine-Dynamotor Unit Disassembly/Assembly (Continues)

8. Disconnect the wiring harnesses (F) of the dynamotor (G) from the electrical cable (H) and the batteries (I) (mark each position for proper reassembly).
9. Disconnect the engine start electrical connector (J).
10. Disconnect the engine ground (K).
11. Remove the four fastening nuts (L) of the engine holder (M).
12. Remove the fastening screws and then remove the case (N).
13. Disengage the engine oil drain hose (P), from the fastening clamps (Q).
14. Place a proper and safe lifting belt (R) transversally on the flange (S), as shown in the figure (the belt (R) have to slide smoothly along the dynamotor).
15. With a proper hoisting system, carefully lift the dynamotor assembly and let it swing slightly to avoid the obstacles (Weight of the engine-dynamotor unit: 40 kg)

Assembly

16. Assemble the components in the reverse order of disassembly.

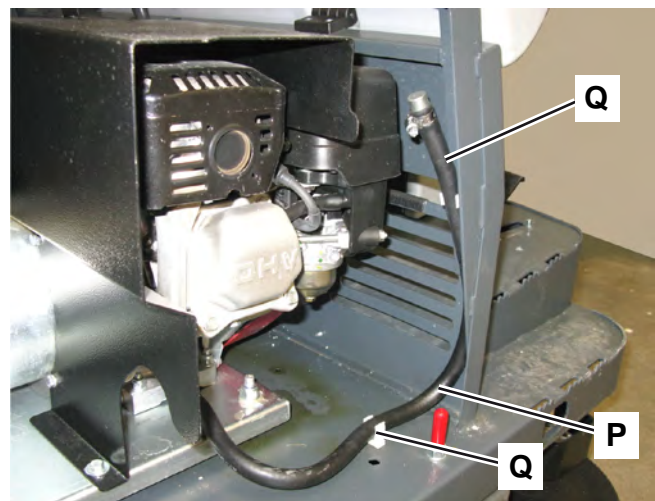
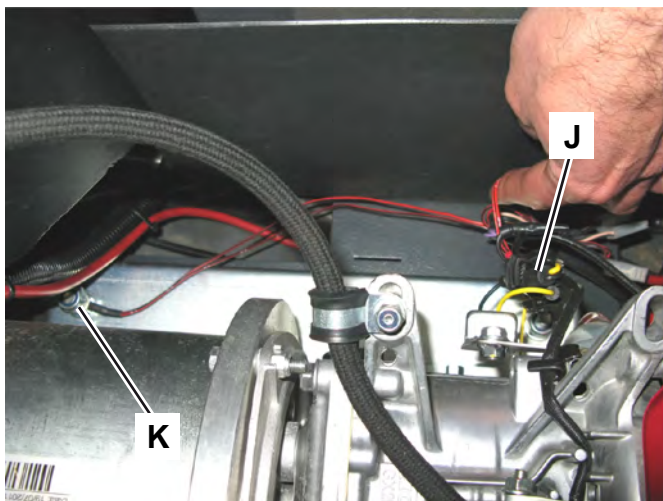
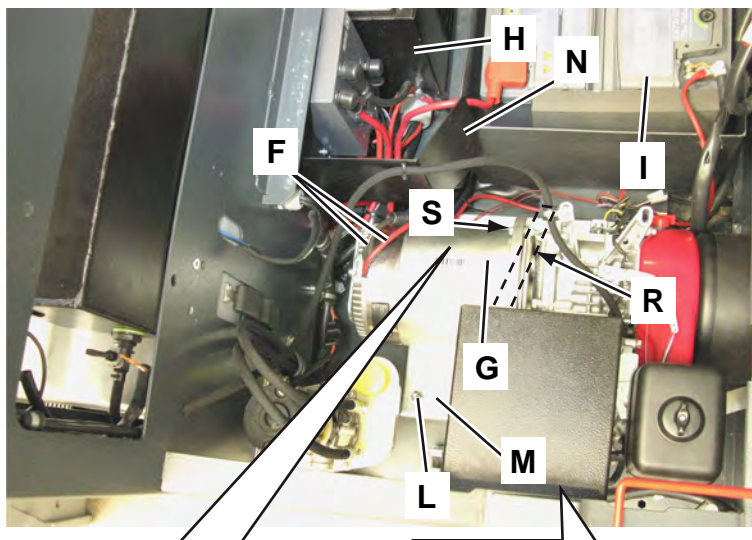

Engine Unit Disassembly/Assembly

Disassembly

1. Remove the engine-dynamotor unit (see the procedure in the previous paragraph).
2. Remove the dynamotor unit (see the procedure in Electrical System paragraph).
3. Remove the screws (A) and separate the engine assembly (B) from the holder (C). Engine weight: 24 kg approx.
4. If necessary, unscrew the three screws (D) and remove the air deflector (E) from the engine.

Assembly

5. Assemble the components in the reverse order of disassembly.

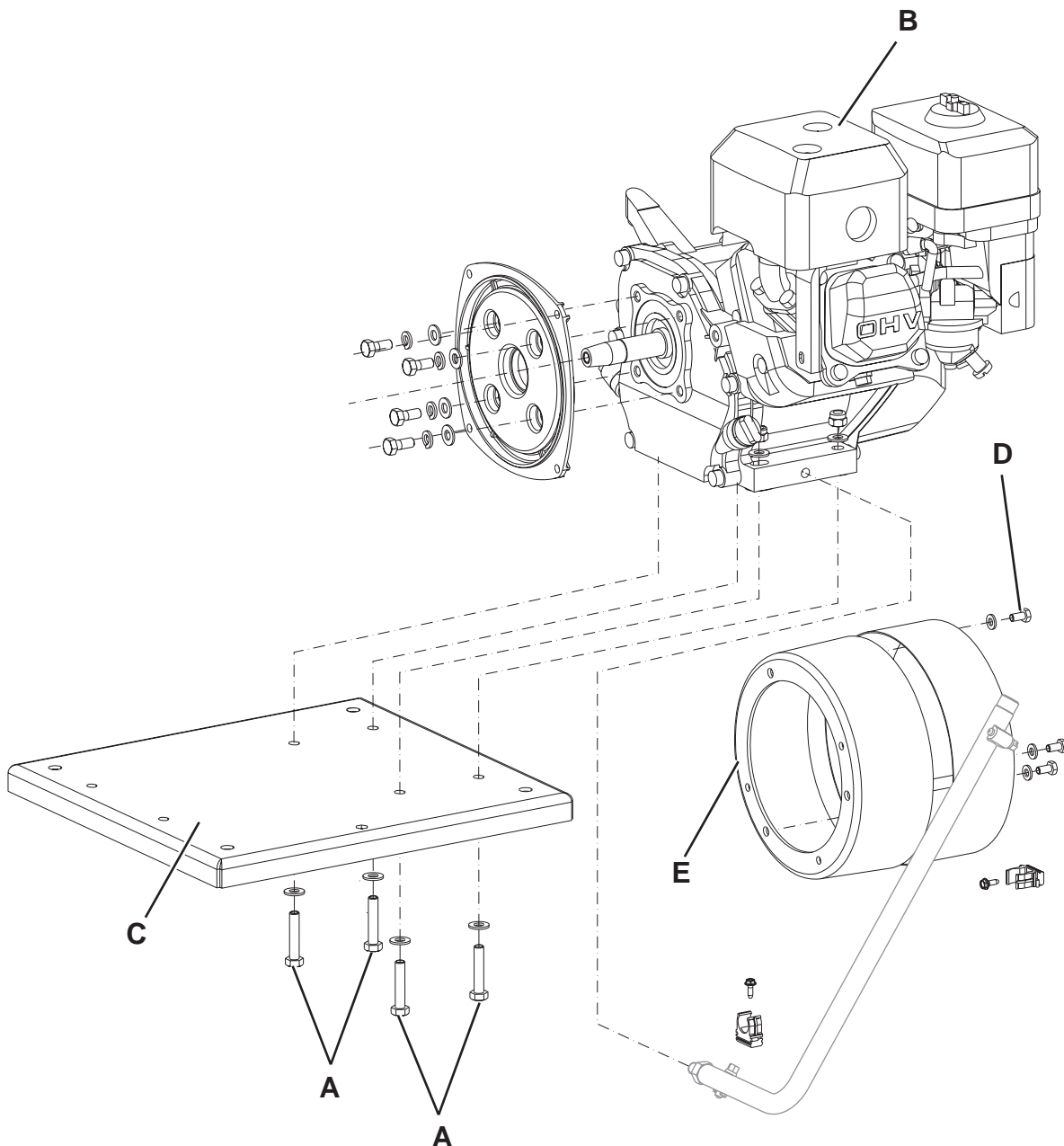

Specifications

Engine System - Petrol	Values
	SW4000 Petrol
Make	Honda
Model	GX-200
Regulated power (ISO 1585)	6.7 kW
Working speed	2,750 ± 50 rpm
Oil type	SAE 5 W 30 - SYNTHETIC API SJ
Average consumption	0.45 gph US (1.7 liters/hour)
Fuel tank capacity	2.0 gal US (7.8 liters)
Reserve	0.6 gal US (2.2 liters)
Length Width Height (engine only)	12.3 x 14.8 x 13.2 in (313 x 376 x 335 mm)
Displacement (bore x stroke)	12 in ³ [2.68 x 2.13 in] (196 cm ³ [68 x 54 mm])
Maximum output	4.8 kW (6.5 PS) at 3,600 min (rpm)
Max torque	117 lbf•in - 2,500 rpm (min) (13.2 N•m (1.35 kgf•m) at 2,500 min (rpm))
Engine oil quantity	0.16 gal US (0.60 liters)
Cooling system	Forced air
Starting system	Transistor magnet
PTO shaft rotation	Counter-clockwise
Distance between the spark plug electrodes	0.028 - 0.031 in (0.70 - 0.80 mm)
Idle speed	1,400 min (rpm)
Valve clearance (cold)	INTAKE: 0.0059 ± 0.00079 in (0.15 ± 0.02 mm) EXHAUST: 0.0079 ± 0.00079 in (0.20 ± 0.02 mm)
Fuel	Unleaded fuel
	U.S.A.: Pump octane number not less than 86
	Except in the U.S.A.: Research octane number not less than 91
	Except in the U.S.A.: Pump octane number not less than 86
Spark plug	BPR6ES (NGK) W20EPR-U (DENSO)

Engine System - LPG

Functional Description

The engine system generates electric current for all machine functions.

The assembly consists of an internal combustion engine and dynamotor, which are both connected to the main crankshaft.

The engine is a single-cylinder air-cooled LPG type.

The engine start-up is made by the dynamotor to which it is connected.

The dynamotor acts as a starter, using the battery only for the time necessary to start the engine. At a later stage, the running engine supplies the power to the dynamotor to generate the current and to power the electrical systems of the machine. The surplus current is used to charge the batteries.

The engine speed is fixed, 2,750 rpm, to grant a constant current to the electrical system.

The LPG tank is fastened to the relevant holder in the rear side of the machine and connected to the power supply system with a hose and a double safety valve.

When turning the ignition key, the safety solenoid valve opens, the liquid gas passes through the filter in the solenoid valve, thus reaching the pressure reducer.

The IMPCO T60-A-NN-2 two-phase pressure reducer lowers the gas pressure, which then reaches the carburettor.

The LPG system is protected against any overpressure by a relief valve which activates at 27 atm (400 PSI). The fuel reserve warning light turns on when the sensor in the power supply system detects a pressure lower than 1.1. bar.

For safety reasons, if the engine is not started (ignition key to "II") within 2/3 seconds after turning on the control panel (ignition key to "I"), the safety solenoid valve automatically closes the gas power supply. The engine is equipped with an oil level sensor (Oil Alert), which purpose is to avoid damages caused by an insufficient oil quantity in the oil pan. Before the oil level goes below the safety limit, the system (Oil Alert) automatically stops the engine. If the engine stops and do not restart, check the engine oil level before doing any other troubleshooting procedure.

Wiring Diagram

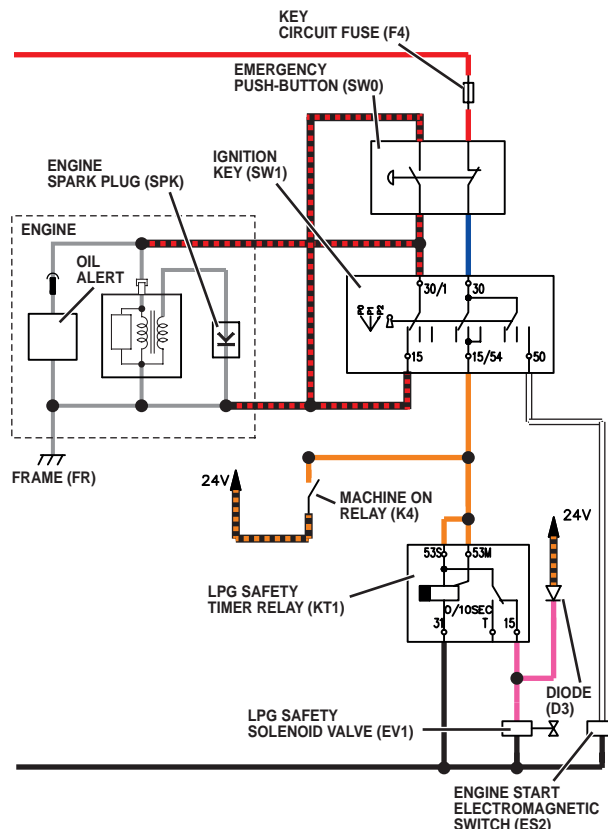

Component Locations

- LPG tank fastening band
- LPG tank
- LPG tank fitting
- LPG tank opening/closing valve
- Hose
- Pipe
- Safety valve
- Diode (D3)

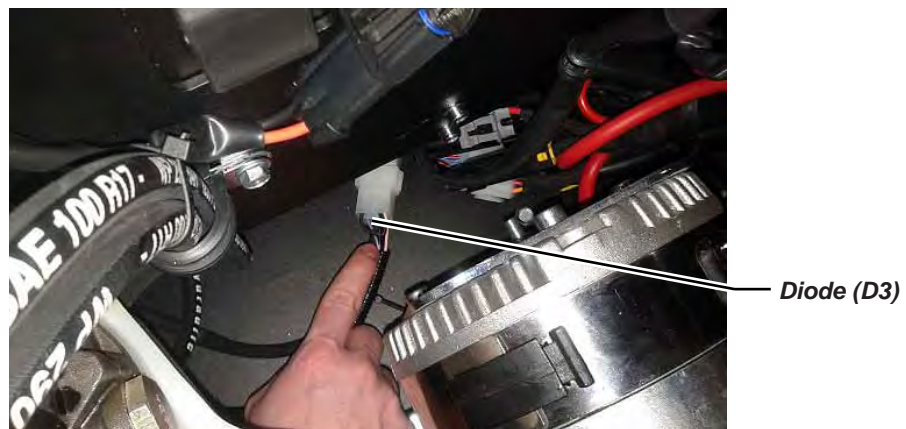
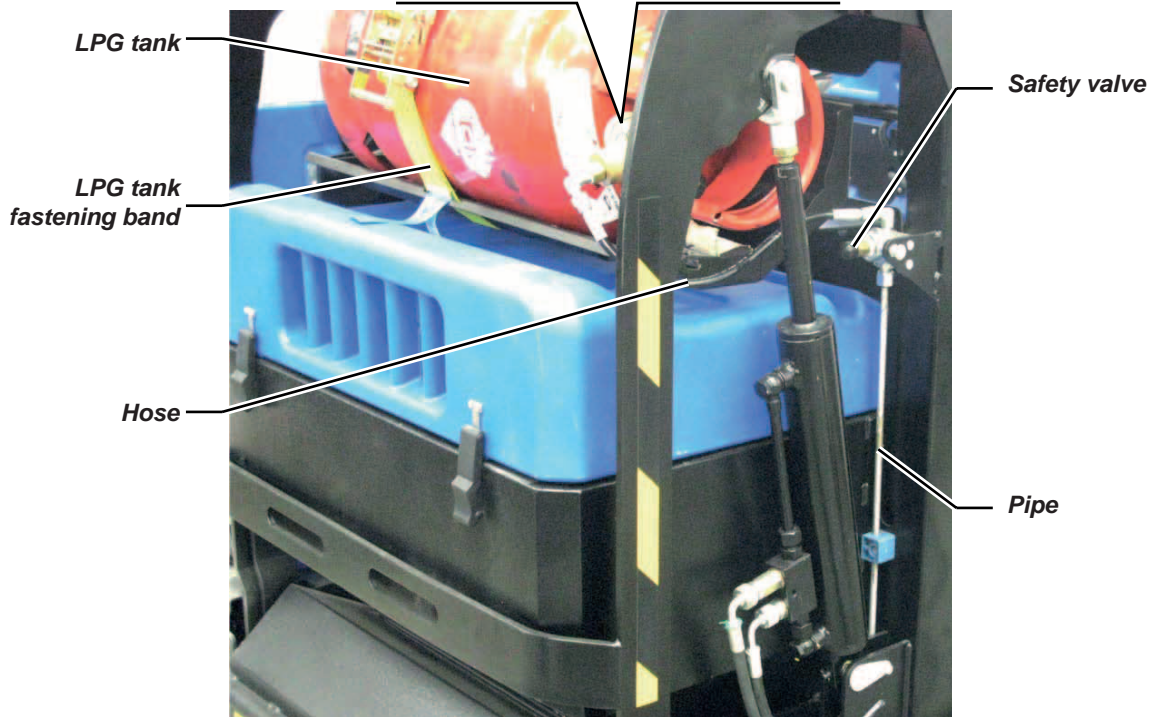
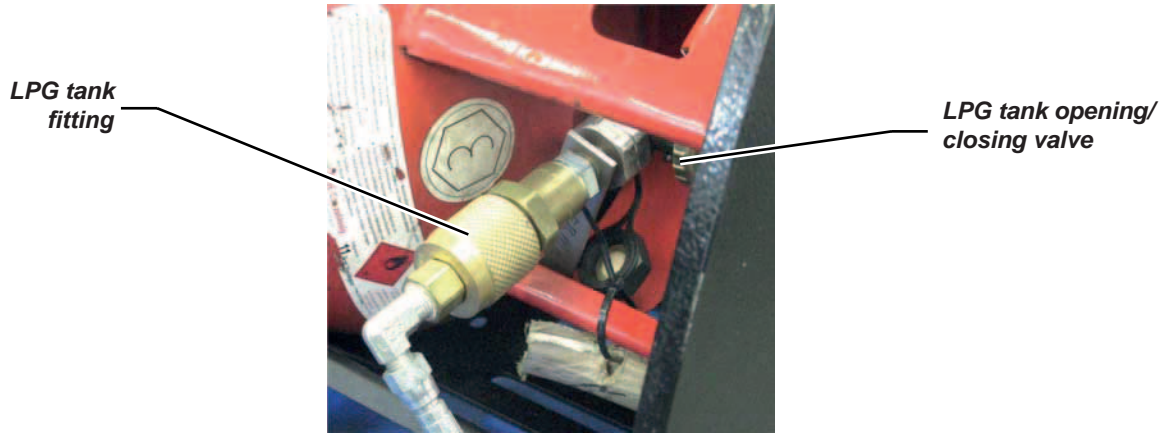

Component Locations (Continues)

- LPG wiring harness
- Engine
- Hose
- LPG pressure regulator
- Hose
- Solenoid valve with filter (EV1)
- Pressure valve (reserve) (S4)

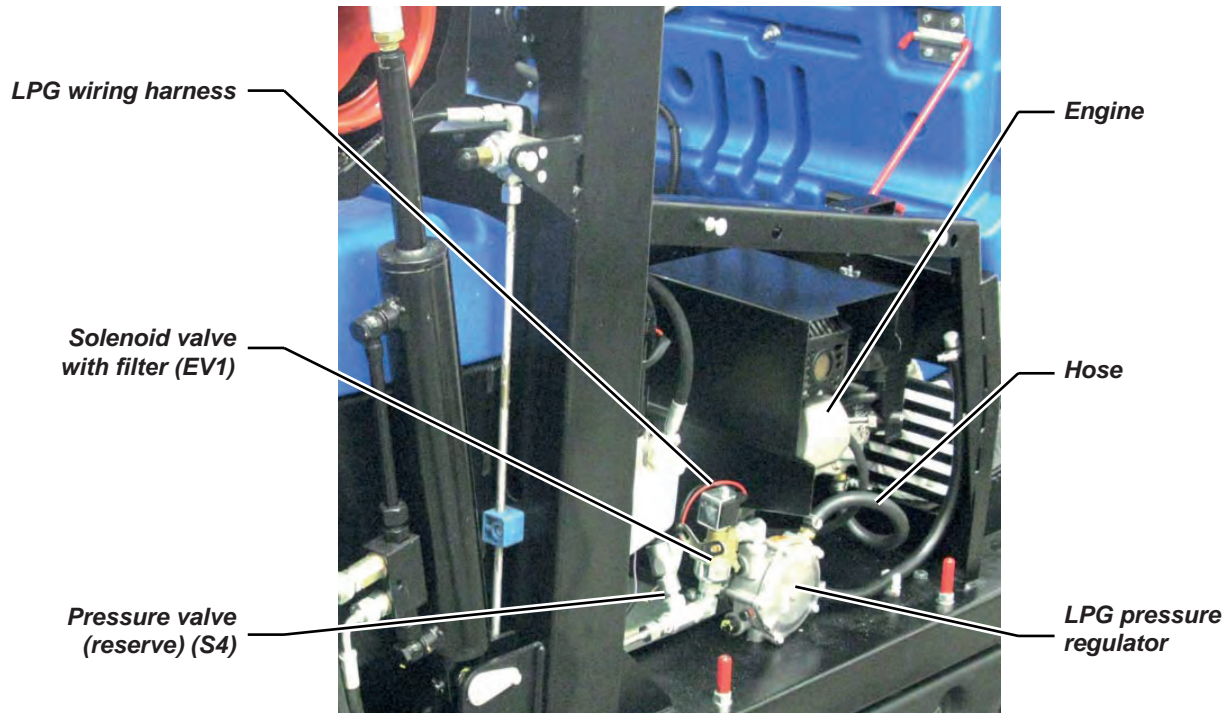

Maintenance and Adjustments

Engine RPM Check

1. To check the engine speed, use the indicator (A) fastened to the engine pulley, with a rev counter light (B) which can be seen from the front outer side of the engine compartment.
2. Alternatively use a rev counter (C) to be applied to the spark plug wire (D).

For the engine rpm, see Specifications paragraph.

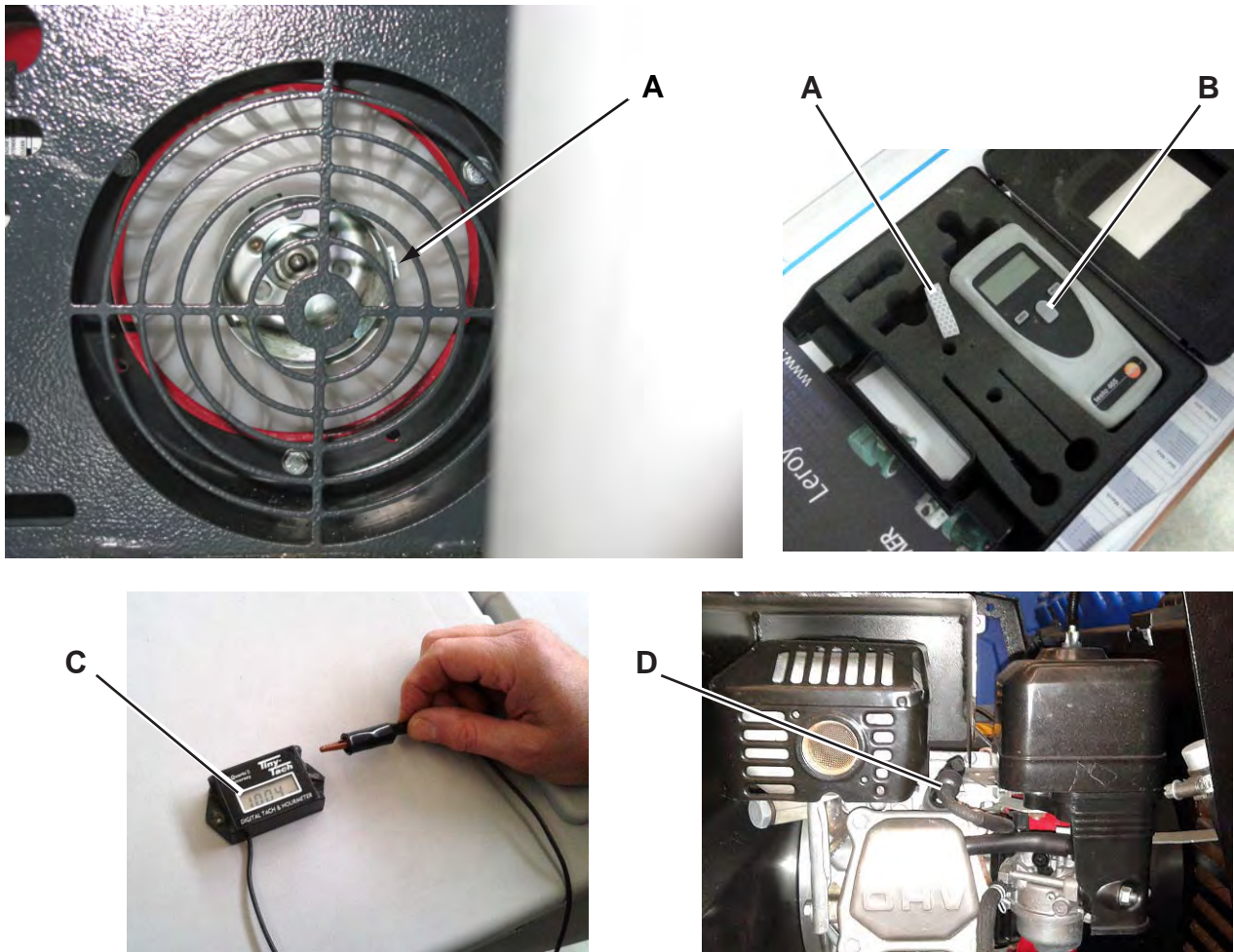

Engine Air Filter Cleaning Check



Warning! *Running the engine without air filters, or with damaged filters, can cause a faster engine wearing.*

1. Drive the machine on a level ground and engage the parking brake.
2. Turn the ignition key to “0”.
3. Open the engine compartment hood with the handle and fasten it with the support rod.
4. Lift and disassemble the right side bulkhead.
5. Remove the wing nut (A) and remove the cover (B).
6. Remove the wing nut (C) and disassemble the filter element.
7. Separate the foam filter (D) from the paper filter (E).
8. Check both filters and replace them if necessary. Replace the paper filter (D) when required (see the scheduled maintenance table).
9. To use again the filters, clean them as shown below:
 - Paper filter (E): Hit the filter several times against a hard surface to remove the dust, or blow compressed air (no more than 207 kPa (2.1 kgf/cm)) from inside the filter. Do not use a brush, otherwise the fibre will be damaged.
 - Foam filter (D): Clean with warm water and soap, rinse and let it dry completely, or clean with a non-flammable solvent and let it dry. Soak the filter in clean engine oil, then squeeze it to remove the surplus oil.
10. Clean with a wet cloth the base (F) and the cover (B) of the air filter. Pay attention to avoid that dirt enters the air duct (G) to the carburettor.
11. Assemble the foam filter (D) on the paper filter (E), then assemble the filter element. Ensure that the gasket (H) is properly placed under the filter element. Screw down the filter element wing nut (C).
12. Install the cover (B) and screw down the wing nut (A).
13. Perform steps 4 and 3 in the reverse order.

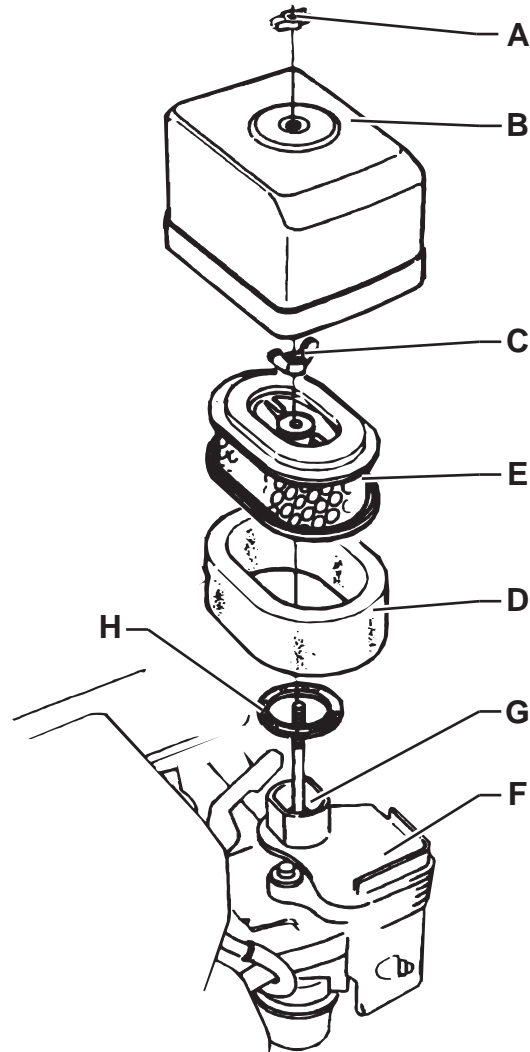

Engine Oil Level Check



Caution! *Running the engine with a low oil level can damage the engine itself.*



Note: *The oil alert system will automatically stop the engine before the oil level goes down under the safety limit. To avoid a sudden engine stop, always check the oil level before each start-up.*

1. Drive the machine on a level ground and engage the parking brake.
2. Turn the ignition key to “0”.
3. Open the engine compartment hood with the handle and fasten it with the support rod.
4. Lift and disassemble the right side bulkhead.
5. Remove the oil filler plug/dipstick (A) and clean it.
6. Insert the oil filler plug/dipstick in the filler neck (B), but do not tighten it, then remove it to check the oil level.
7. If the oil level is near or under the lower limit mark (C) on the dipstick, top up with the specified oil up to the upper limit mark (D) (lower edge of the oil filling hose). Do not overfill.
8. Install the oil filler plug/dipstick (A).
9. Perform steps 4 and 3 in the reverse order.

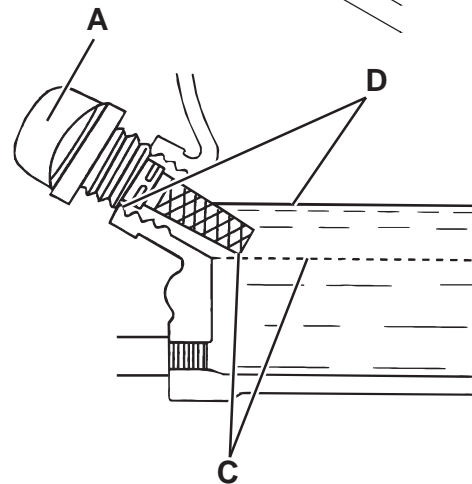
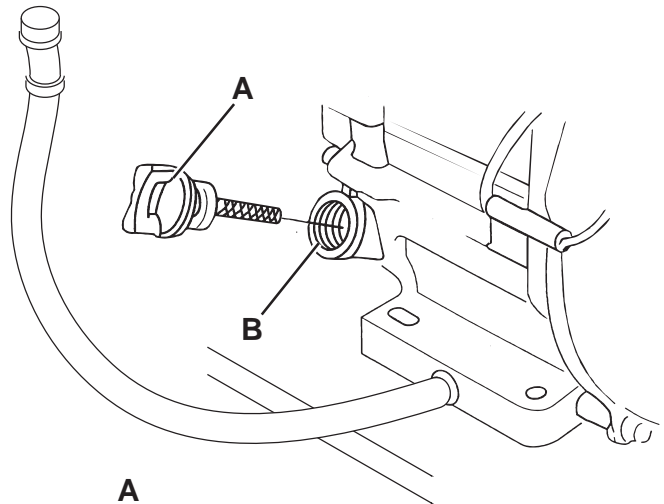

Engine Oil Change



Caution! *The discharged engine oil has to be disposed of properly according to the Law in force.*



Note: *It is advisable to change the oil when the engine is still hot, to make the oil downflow easier.*

1. Drive the machine on a level ground and engage the parking brake.
2. Turn the ignition key to “0”.
3. Open the engine compartment hood with the handle and fasten it with the support rod.
4. Lift and disassemble the right side bulkhead.
5. Remove the oil filler plug/dipstick (A). Place the hose (E) in a position that eases the oil drain, then remove the plug (F).
6. Drain all the engine oil through the hose (E) and collect it in a proper container.
7. Install the oil drain plug (F) and place the hose (E) back to the original position.
8. Pour new oil in the filler neck (B) up to the upper limit mark (D) (lower edge of the oil filling hose) on the dipstick.

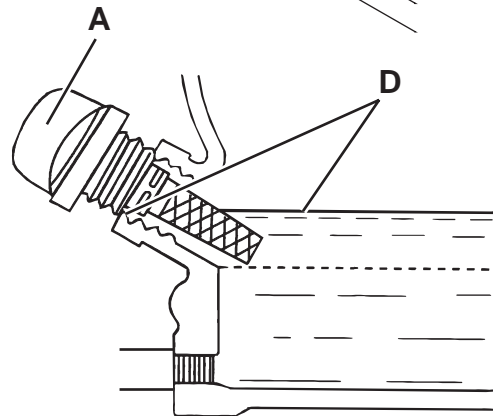
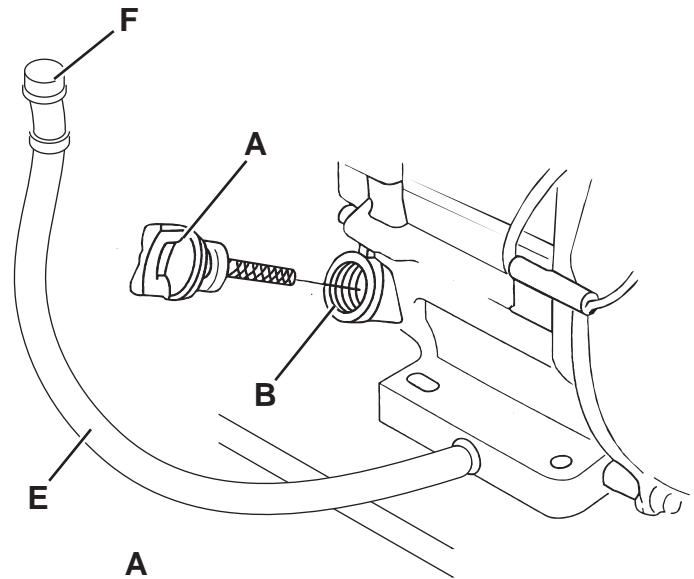

P200133



Note: *For the engine oil type and quantity, see Specifications paragraph.*

9. Install the oil filler plug/dipstick (A) and tighten it.
10. Perform steps 4 and 3 in the reverse order.

Engine Spark Plug Check/Replacement

For the type of spark plug to be used, see Technical Data chapter.



Warning! *A wrong spark plug can damage the engine.*

1. Drive the machine on a level ground and engage the parking brake.
2. Turn the ignition key to “0”.
3. Open the engine compartment hood with the handle and fasten it with the support rod.
4. Lift and disassemble the right side bulkhead.
5. Disconnect the spark plug cap and remove dirt around the spark plug.
6. Remove the spark plug with a proper wrench (A).
7. Check the spark plug. Replace it if it is damaged, dirty, if the sealing washer (B) is damaged or if the electrode is worn.
8. Measure the distance between the spark plug electrodes with a feeler gauge. Correct the distance by bending carefully the side electrode (C). The distance between the electrodes has to be of 0.70 - 0.80 mm.
9. Install the spark plug manually with great care, to avoid tightening it improperly.
10. Once the spark plug is in place, tighten it with a proper wrench to press the sealing washer.
11. When a new spark plug is installed, tighten 1/2 turn once the spark plug is in place to press the washer.
12. When the original spark plug is reinstalled, tighten 1/8 - 1/4 turn once the spark plug is in place to press the washer.
13. Perform steps 4 and 3 in the reverse order.

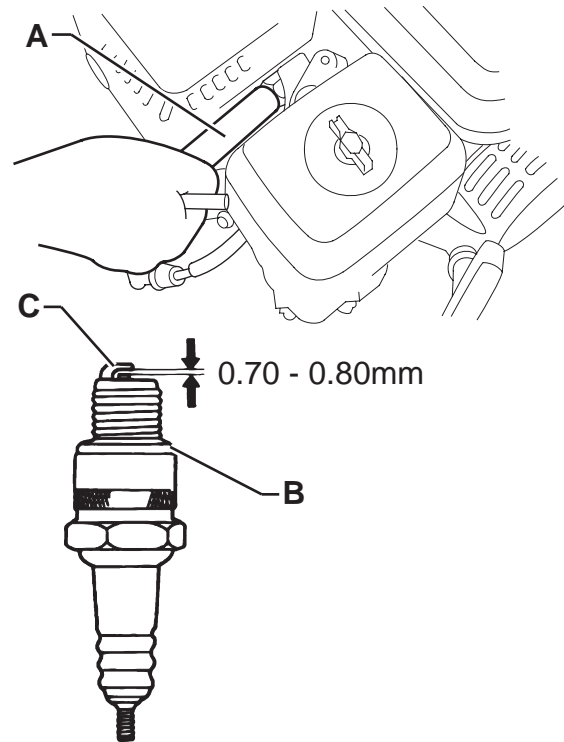

P200135



Note: *A loose spark plug can overheat and damage the engine. Do not overtighten, otherwise the threads in the cylinder head can be damaged.*

Engine Baffle Plate Cleaning



Warning! *If the engine was running, the silencer will be very hot. Let it cool down before operating on the baffle plate.*

1. Drive the machine on a level ground and engage the parking brake.
2. Turn the ignition key to "0".
3. Open the engine compartment hood with the handle and fasten it with the support rod.
4. Lift and disassemble the right side bulkhead.
5. Remove the screws (A) and carefully remove silencer guard (B).
6. Remove the screws (C) and remove the exhaust manifold (D).
7. Remove the screws (E) and carefully remove silencer guard (F).
8. Remove the screw (G) and remove the baffle plate (H) from the silencer.
9. Use a brush to remove the carbon deposits from the baffle plate shield (I). Take care not to cause damage to the shield. Replace the baffle plate if it cracked or perforated.
10. Install the baffle plate (H), the silencer guard (F) and the exhaust manifold (D).
11. Assemble the components in the reverse order of disassembly.

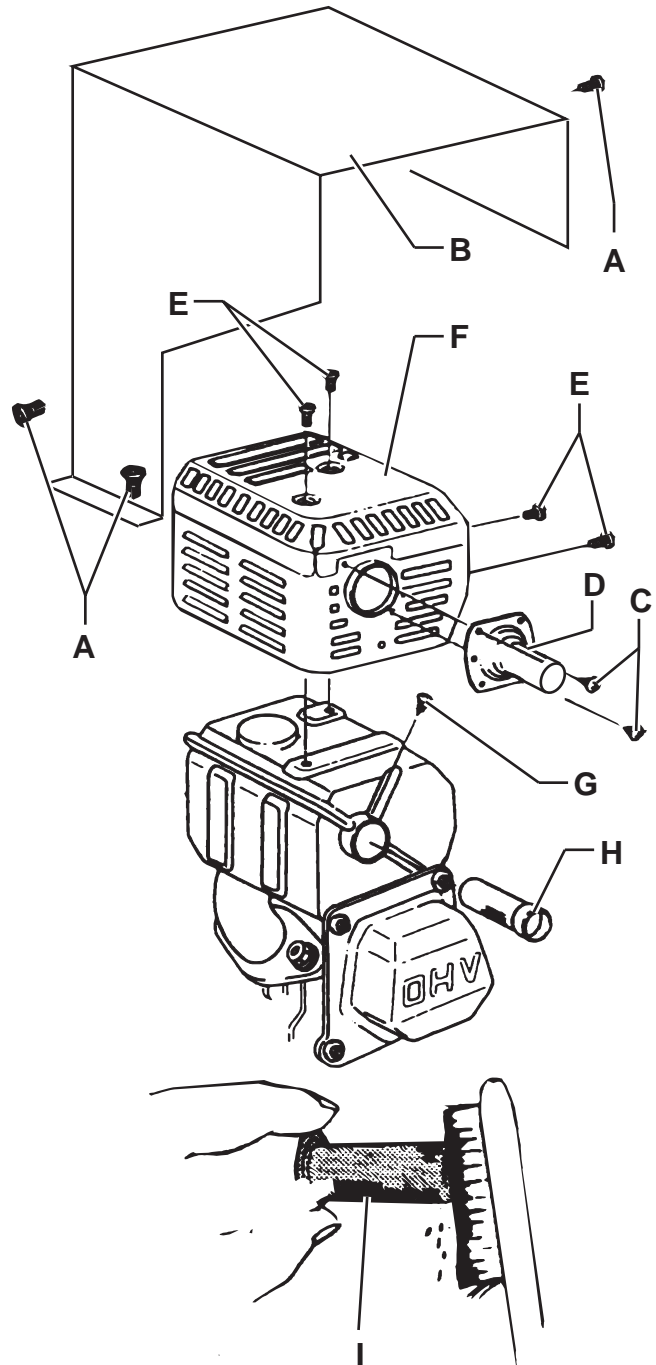

LPG System Leakage Check



Warning! *This procedure has to be performed by personnel qualified to handle the LPG systems, according to the law in force. Moreover, it is necessary to wear accident-prevention clothes, according to the law in force (heavy gloves, antistatic non-synthetic clothes, suitable to cover the whole body, antistatic and antispark shoes, helmets with visor; etc.).*

1. After any maintenance or replacement procedure involving operations on the fittings or movement of LPG system components, check for any LPG gas leaks as shown below.
2. Turn the ignition key to “0” and engage the parking brake.
3. Open the engine compartment hood with the handle and fasten it with the support rod.
4. Remove the machine right body side, by lifting it to disengage it from the fasteners.
5. If the engine is hot, wait that it cools down.
6. By proceeding as shown in the User Manual, check that the fitting (A) of the hose (B) is properly connected to the fitting (C) of the LPG tank (D). Check that the valve (E) of the LPG tank (D) is closed.

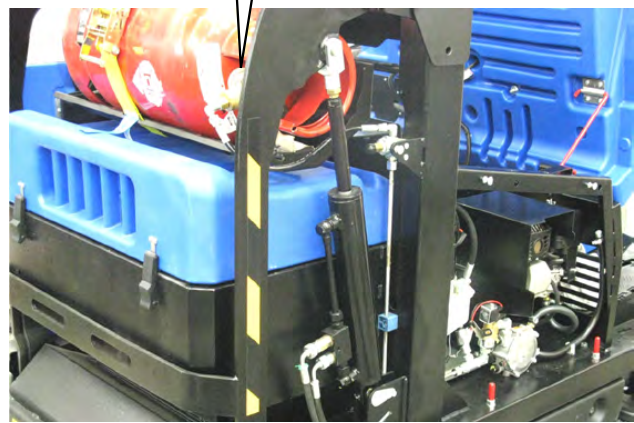
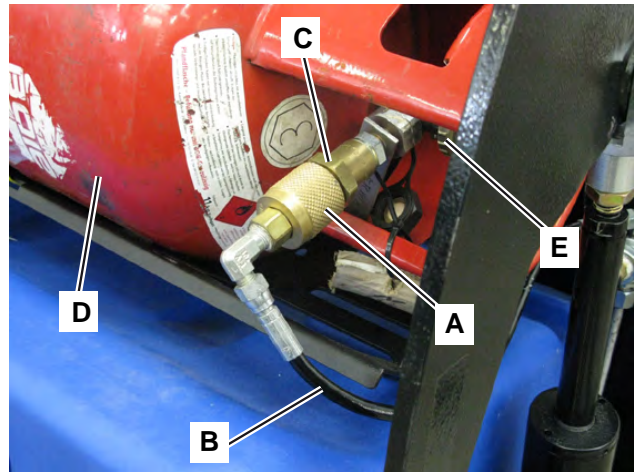

P200142

LPG System Leakage Check (Continues)

7. Apply evenly the spray product that detects gas leaks “SUPER BALL, OFF. PROD. C.C.I.A.A. 186231 (VI)” (or equivalent) on all the fittings of the LPG system, starting from the LPG tank fitting (A) to the fitting (F) between the hose and carburettor (G). Proceed according to the instructions on the package of the spray product.
8. Open the LPG tank valve, then check for LPG gas leaks, shown by gas bubble development, on all LPG system fittings, starting from LPG tank fitting (A) to the solenoid valve (H).
9. Turn the ignition key to the first position “I”, then check for LPG gas leaks, shown by gas bubble development, on all LPG system fittings, starting from the solenoid valve (H) to the fitting (F).
10. In case LPG leaks are detected, it is necessary to open the relevant fittings, manage them as described, then tighten them again (see the procedure in “LPG System Hose Removal/Installation”). Perform again LPG System Leakage Check.

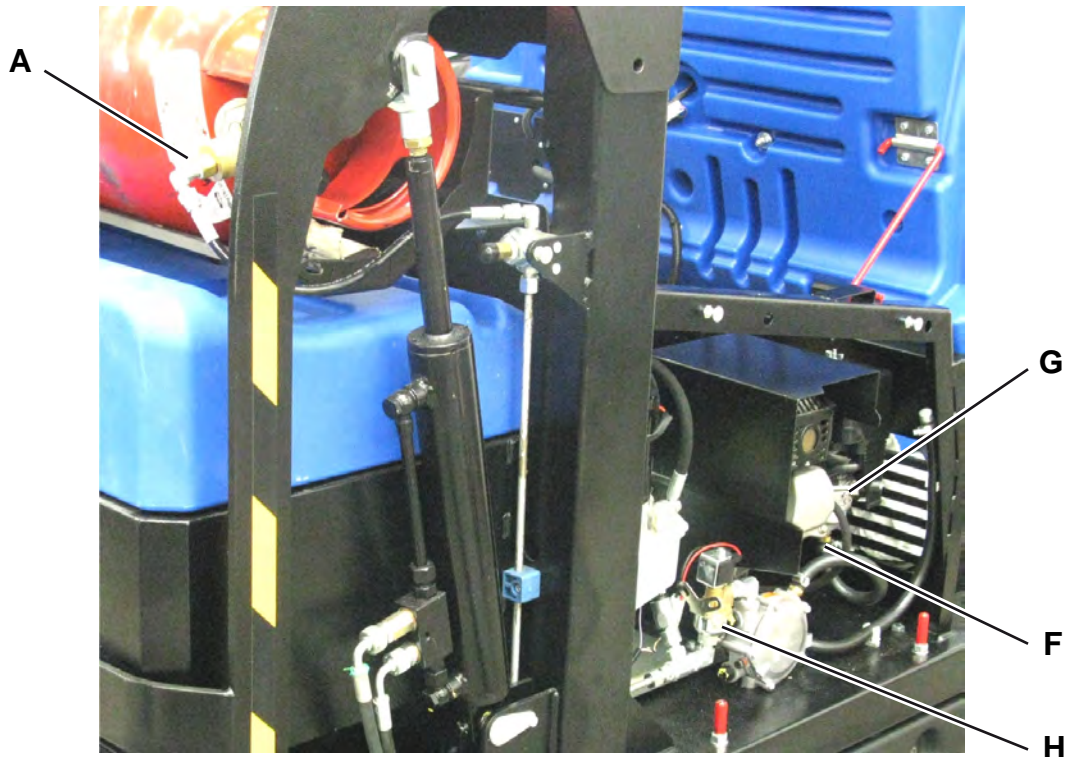

Solenoid Valve Filter Cleaning



Warning! *This procedure has to be performed by personnel qualified to handle the LPG systems, according to the law in force. Moreover, it is necessary to wear accident-prevention clothes, according to the law in force (heavy gloves, antistatic non-synthetic clothes, suitable to cover the whole body, antistatic and antispark shoes, helmets with visor; etc.).*

Disassembly

1. Empty the LPG system (see the procedure in LPG System Emptying).
2. Turn the ignition key to “0” and engage the parking brake.
3. Open the engine compartment hood with the handle and fasten it with the support rod.
4. Remove the machine right body side, by lifting it to disengage it from the fasteners.
5. Turn the fasteners and remove the machine right door.
6. If the engine is hot, wait that it cools down.
7. Unscrew the fitting (A).



Caution! *For disassembly/assembly of the various hoses and fittings of the LPG system, refer to the procedure in “LPG System Hose and Fitting Disassembly/Assembly”.*

8. Loosen the retaining bands (B) and disconnect the hoses (C).
9. Disconnect the electrical connections (D) and (F).

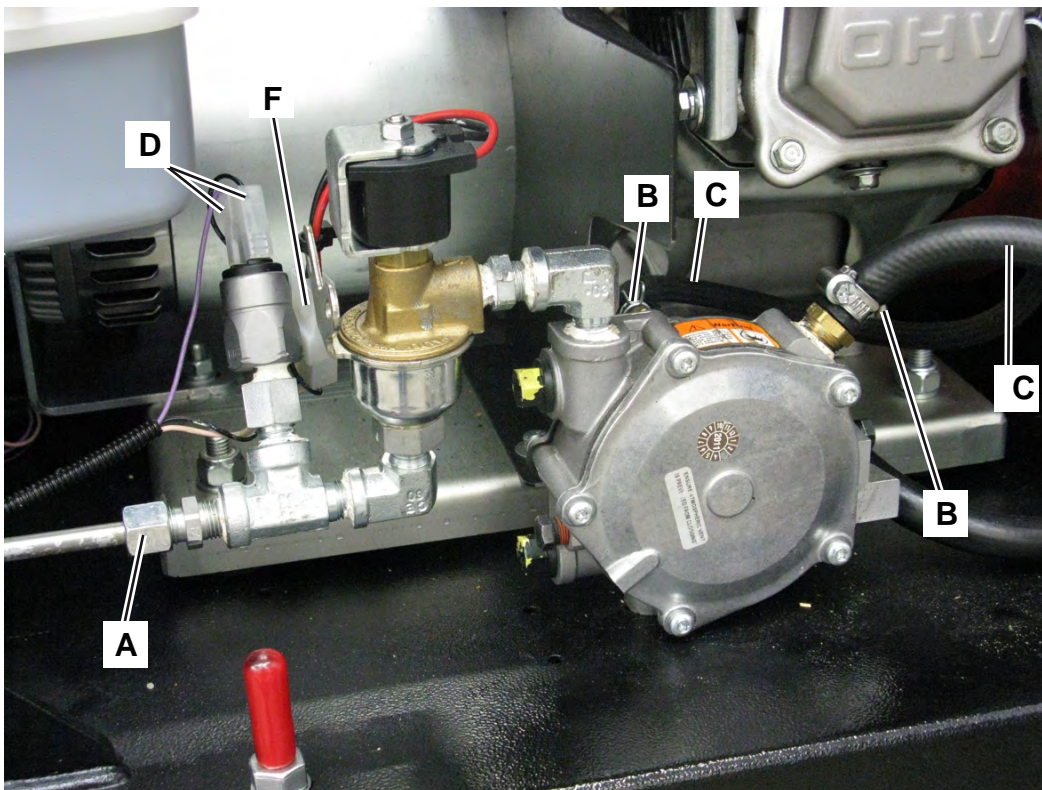

Solenoid Valve Filter Cleaning (Continues)

10. Remove the fastening screws (G) of the pressure regulator assembly with valves (H).
11. Remove the pressure regulator assembly with valves (H).
12. At the workbench, remove the “T” fitting (I) from the fitting (L).
13. Remove the fitting (L) from the fitting (M) of the solenoid valve (N).

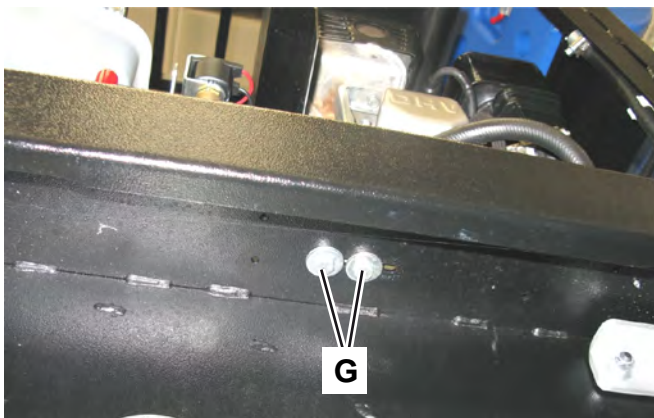
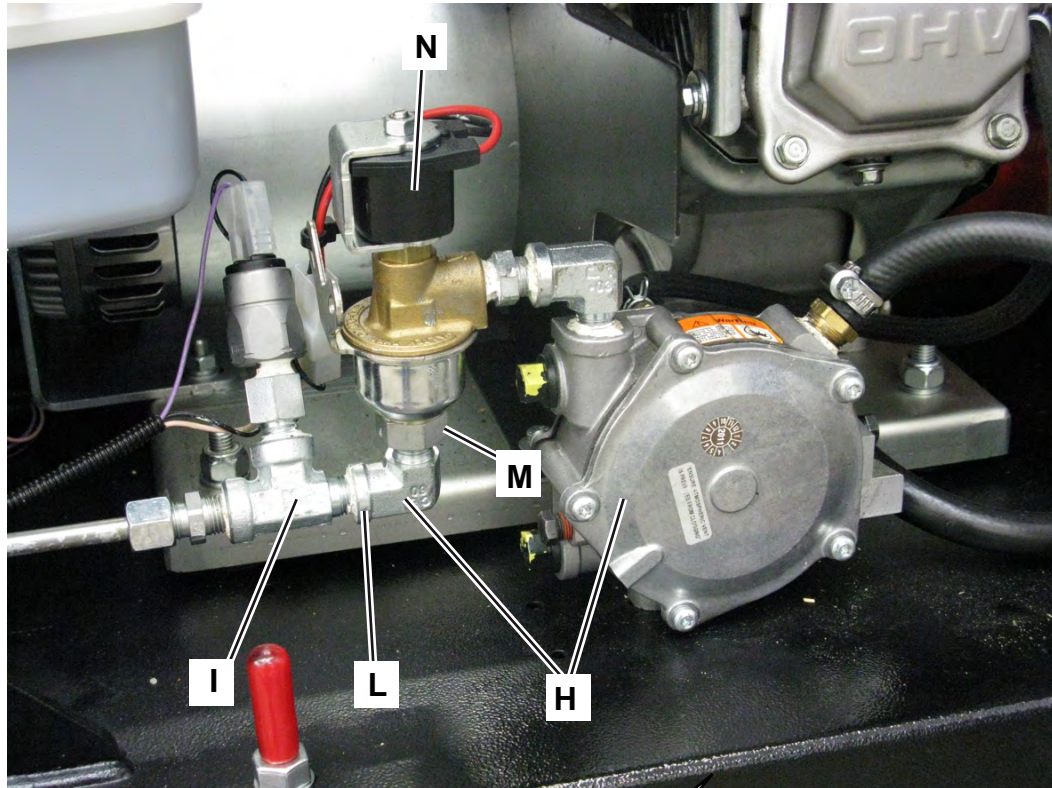

Solenoid Valve Filter Cleaning (Continues)

14. Overturn the solenoid valve (N) and fasten its body on a vice (P) with soft jaws.
15. Unscrew the solenoid valve fitting (M).
16. Remove the filter holder (Q).

Inside the filter holder there is a cylinder with magnet (R) which will be cleaned and placed in the lower side of the filter holder itself (as shown in the figure).

The filter holder gasket (S) has to be replaced with the corresponding spare part, before reassembly.

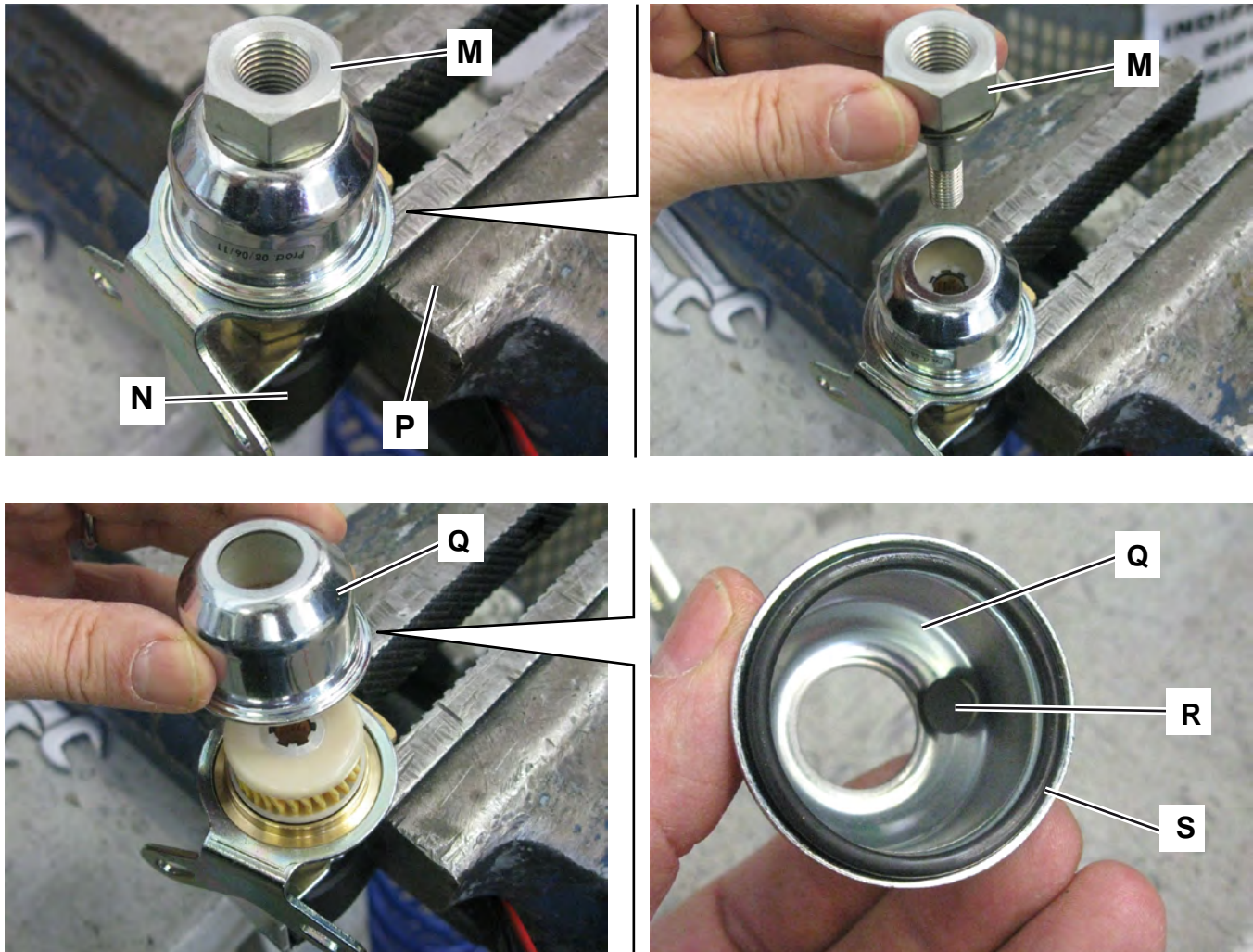

Solenoid Valve Filter Cleaning (Continues)

17. Remove the filter (T).

The filter holder gasket (U) has to be replaced with the corresponding spare part, before reassembly.

18. Remove and discard the gaskets (U) and (S), then clean the filter (T), the flange (V) of the solenoid valve body, the filter holder (Q) and the fitting (M) with compressed air (maximum pressure 6 Bar). If necessary, replace the filter (T).

Take care in order not to damage the remaining part of the solenoid valve; do not sink the coil in solvent or water.

Assembly

19. Assemble the components in the reverse order of disassembly, and note the following:

- On the solenoid valve, tighten the fitting (M) at the tightening torque of approximately 16.6 Nm (147 in Lbs).

20. Perform the LPG System Leakage Check (see the procedure in LPG System Leakage Check paragraph).

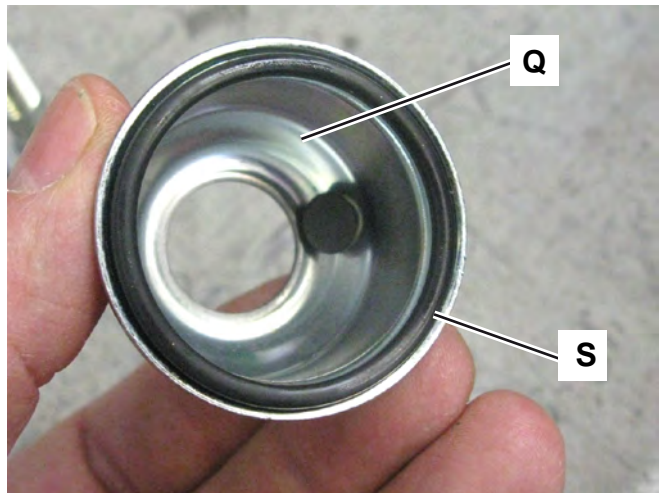
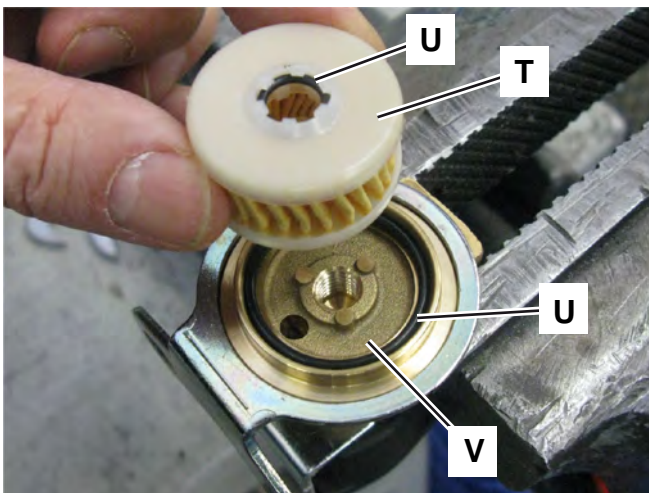
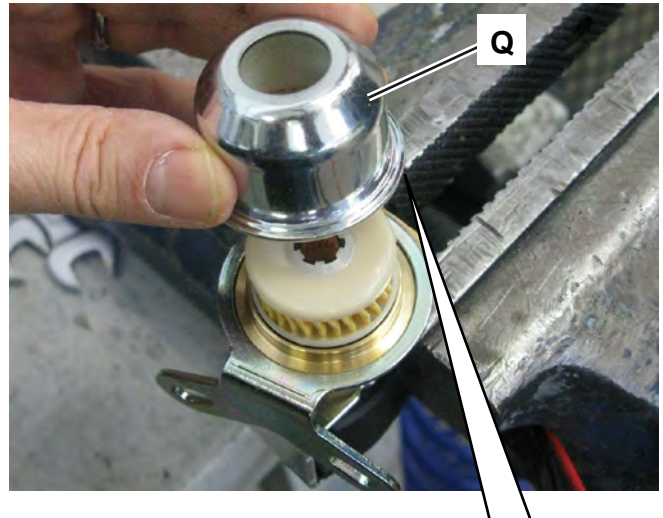
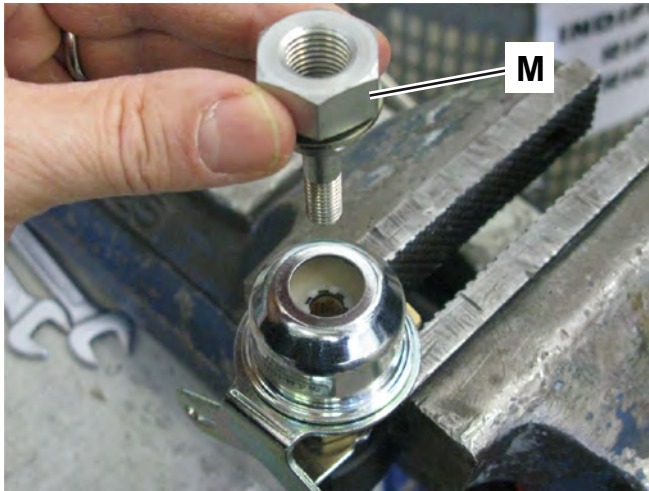

CO₂ Adjustment



Warning! This procedure has to be performed by personnel qualified to handle the LPG systems, according to the law in force.

Check the CO₂ emissions.

1. With the proper tool, check the engine CO₂ emissions, according to the law in force in the country where the machine is used.
2. If necessary, adjust the engine CO₂ emission, according to the following procedure.

Adjustment

3. Turn the ignition key to “0” and engage the parking brake.
4. Open the engine compartment hood with the handle and fasten it with the support rod.
5. Remove the machine right body side, by lifting it to disengage it from the fasteners.
6. Remove the sealant from the housing (A) of the LPG pressure regulator (B).
7. Restart checking and adjusting the engine CO₂ emissions, then adjust the emission value by turning the screw (C) as necessary.
8. After adjusting, apply sealant to the housing (A).

Reassembly

9. Perform steps 4 and 5 in the reverse order.

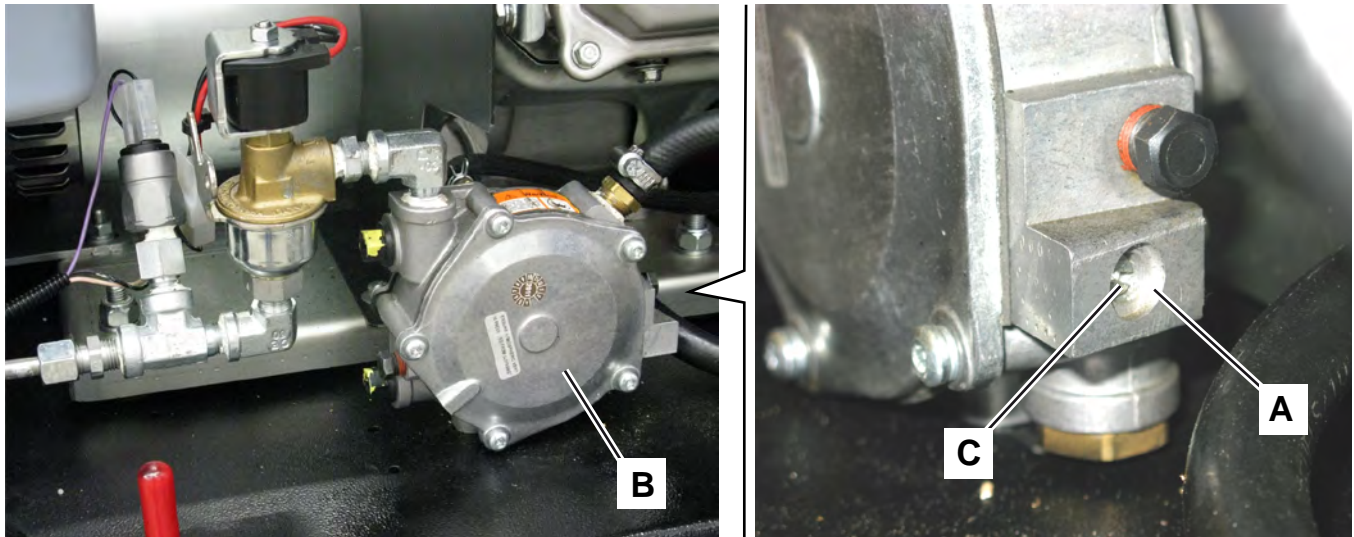

Troubleshooting

Trouble	Possible causes	Remedy
The engine does not start	The fuel does not reach the carburettor.	Check that the tank valve is open (LPG)
	The air control is in standard position.	Turn the lever to cold start position.
	The oil level is low. The Oil Alert sensor is activated.	Top up with the recommended oil to the proper level
	The spark plug is damaged, dirty or the distance between the electrodes is wrong	Correct the distance between the electrodes and replace the spark plug
	The spark plug is wetted with fuel	Dry the spark plug and reinstall it. Start the engine with the choke lever turned to MAX position.
	The spark plug does not produce a spark.	Check or replace the spark plug.
	The fuse (F3) and/or (F0) is open.	Check/replace the fuses.
	The electromagnetic switch (ES2) is faulty	Replace
	The LPG safety relay (KT1) is faulty	Replace
	The batteries are discharged.	Recharge with a proper battery charger.
The emergency push-button has been pressed.	Check and release the emergency push-button.	
The engine loses power or stops during operation.	The filter element or elements are clogged	Clean or replace the filter elements
	Poor quality power supply	Replace the tank.
	The fuel filter is clogged, the carburettor is broken, the start system is broken, the valves are locked, etc.	Replace or repair the faulty components as necessary (take the engine to an authorized Honda service centre)
The display shows the LOU code.	The working conditions are disadvantageous for the batteries.	Decrease the main broom pressure on the floor.
		Avoid driving uphill for long.
		Turn off the working lights.
		If the problem persist, maybe it is necessary to calibrate the engine rpm.
The display shows the HIU code.	The battery charge is excessive.	Turn off the engine each time the machine is stopped.
		If the problem persist, maybe it is necessary to calibrate the engine rpm.

Removal and Installation

LPG System Emptying



Warning! *This procedure has to be performed by personnel qualified to handle the LPG systems, according to the law in force. Moreover, it is necessary to wear accident-prevention clothes, according to the law in force (heavy gloves, antistatic non-synthetic clothes, suitable to cover the whole body, antistatic and antispark shoes, helmets with visor; etc.).*

1. Before operating on the LPG system for maintenance/replacement of parts, bleed the LPG system, as shown below.
2. Close the LPG tank valve.
3. Start the engine and let it run until it stops because it has run out of LPG.



Warning! *This procedure has to be performed where there is a proper ventilation and under the SAFETY conditions indicated in this Manual.*

4. Turn the ignition key to “0” and engage the parking brake.
5. The LPG system is empty. In the next phases of LPG system part removal, consider that there may be some minimum residual LPG gas leaks.



Warning! *Avoid to come into direct contact with any residual LPG in the system.*

LPG System Hose and Fitting Disassembly/Assembly



Warning! This procedure has to be performed by personnel qualified to handle the LPG systems, according to the law in force. Moreover, it is necessary to wear accident-prevention clothes, according to the law in force (heavy gloves, antistatic non-synthetic clothes, suitable to cover the whole body, antistatic and antispark shoes, helmets with visor; etc.).



Warning! The hoses (A) and (B) has to be replaced periodically, according to the law in force. The hose (B) has to be of a specific length, in order to comply with the safety technical data; it must not be shortened for any reason.

Disassembly

1. Empty the LPG system (see the procedure in the previous paragraph).
2. Turn the ignition key to “0” and engage the parking brake.
3. Open the engine compartment hood with the handle and fasten it with the support rod.
4. Remove the machine right body side, by lifting it to disengage it from the fasteners.
5. If the engine is hot, wait that it cools down.
6. Check that the LPG tank valve is closed.
7. Unscrew and remove the relevant hoses (A), (B) or (C) and/or the relevant fittings, and note the following:

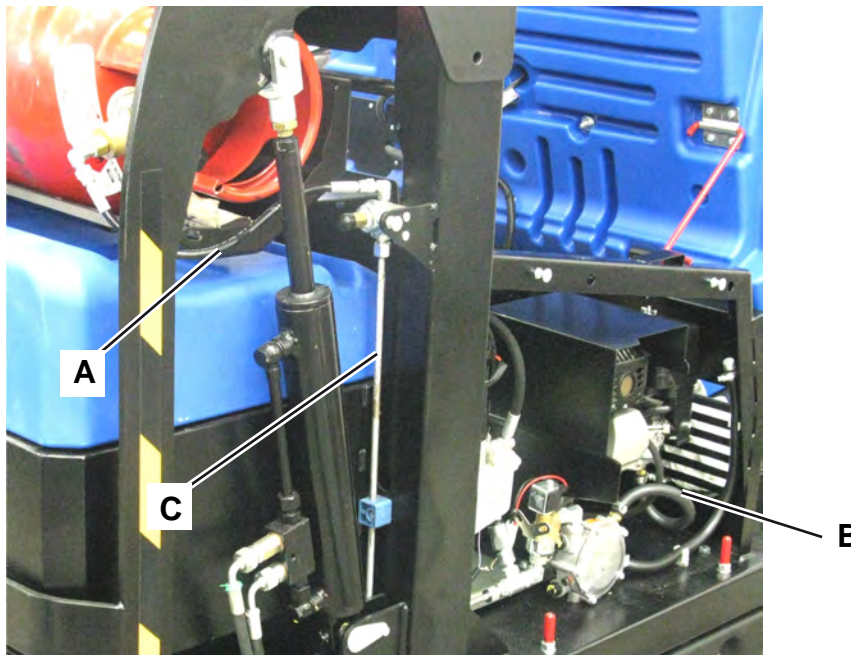

LPG System Hose and Fitting Disassembly/Assembly (Continues)

- The fittings (D) are equipped with inner gaskets.
- The fittings (E) are provided with sealant.



Caution! *If the fittings (E) are turned very slightly, their tightness can be compromised (because the sealant “brakes”), thus those fittings has to be unscrewed and screwed again after having applied new sealant, as shown below.*

- The fittings (F) are equipped with fastening bands.

Assembly

8. Before tightening the fittings (D) clean them accurately and replace the inner gaskets.
9. Before screwing down the fittings (E) carefully remove any remaining of sealant, then apply the new sealant; use PTFE by WURTH saBesto, P/N 0893 511 050 – S/I (or equivalent). Proceed according to the instructions on the package of the product.
10. Before tightening the fittings (F) clean them accurately and replace the fastening bands.
11. After assembling the fittings (E) wait the time necessary for the sealant to harden, before the LPG gas enters the system.

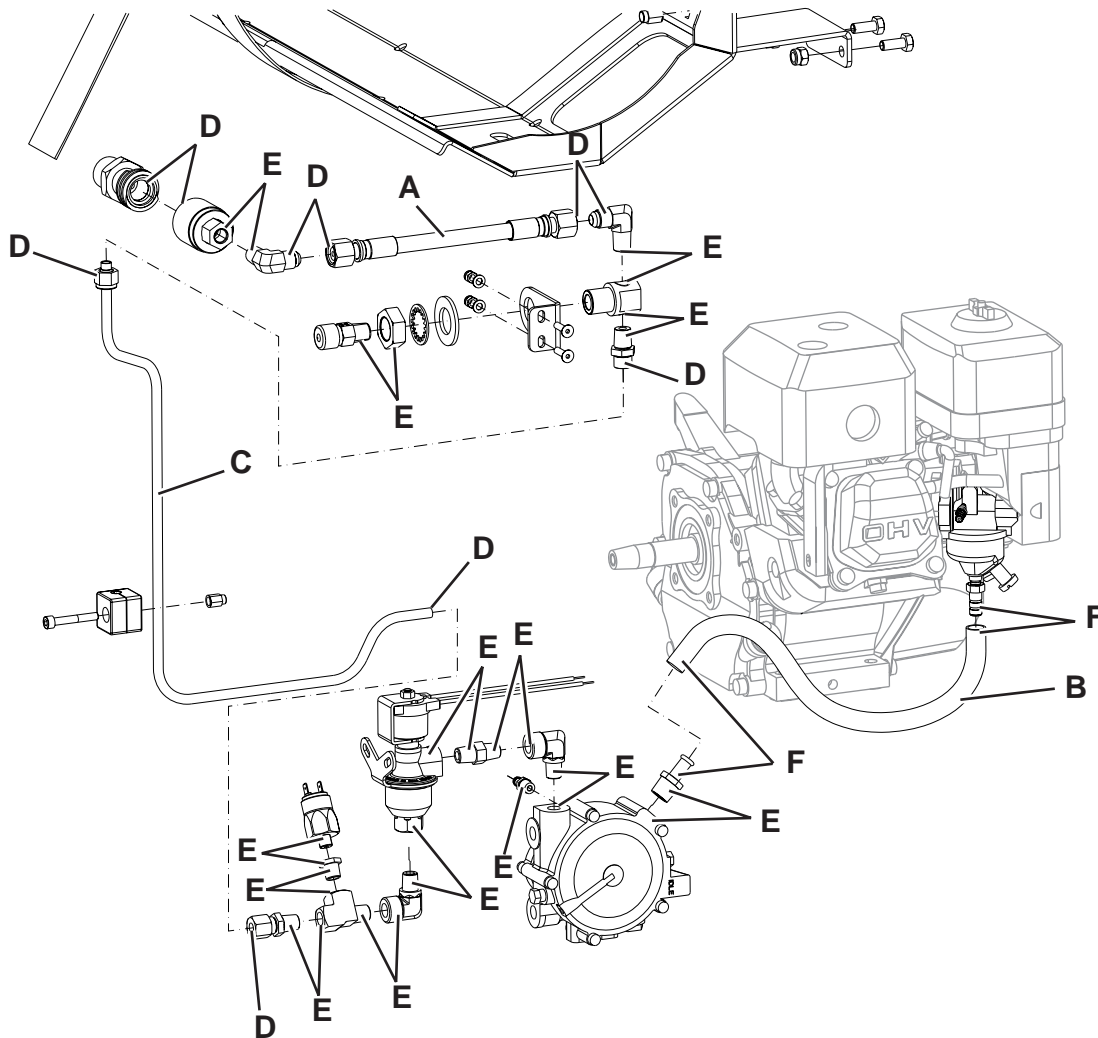

Pressure Regulator Removal/Installation



Warning! This procedure has to be performed by personnel qualified to handle the LPG systems, according to the law in force. Moreover, it is necessary to wear accident-prevention clothes, according to the law in force (heavy gloves, antistatic non-synthetic clothes, suitable to cover the whole body, antistatic and antispark shoes, helmets with visor; etc.).

Disassembly

1. Empty the LPG system (see the procedure in LPG System Emptying).
2. Turn the ignition key to “0” and engage the parking brake.
3. Open the engine compartment hood with the handle and fasten it with the support rod.
4. Remove the machine right body side, by lifting it to disengage it from the fasteners.
5. Turn the fasteners and remove the machine right door.
6. If the engine is hot, wait that it cools down.
7. Unscrew the fitting (A).



Caution! For disassembly/assembly of the various hoses and fittings of the LPG system, refer to the procedure in “LPG System Hose and Fitting Disassembly/Assembly”.

8. Loosen the retaining bands (B) and disconnect the hoses (C).

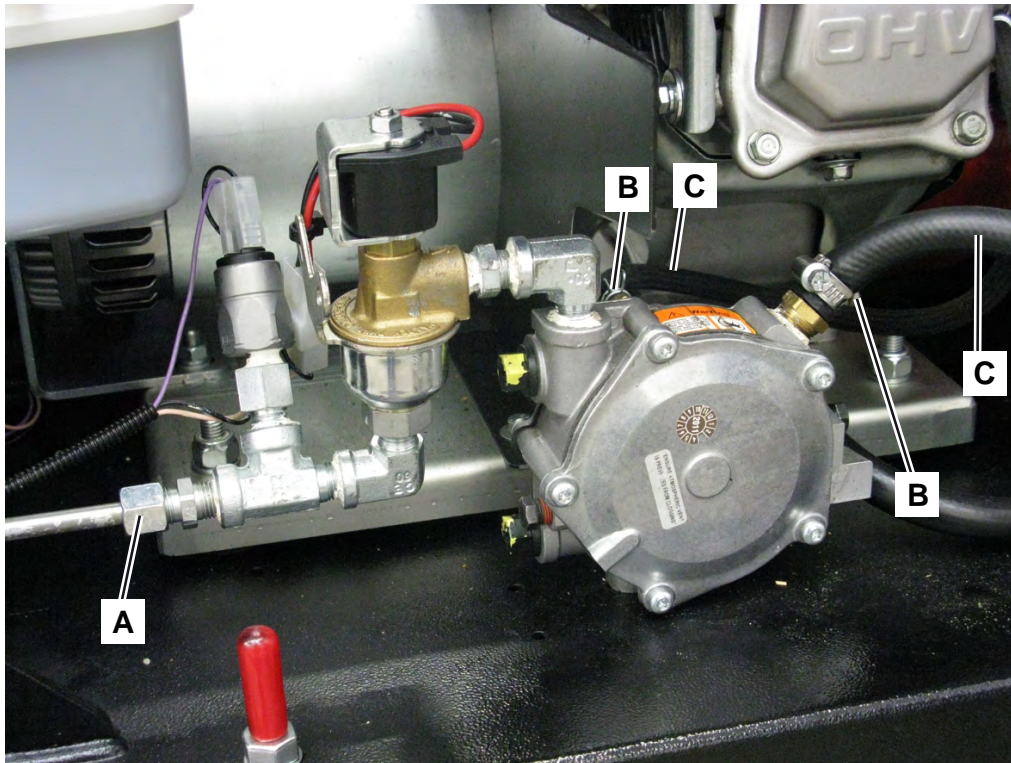

Pressure Regulator Removal/Installation (Continues)

9. Disconnect the electrical connections (D) and (F).
10. Remove the fastening screws (G) of the pressure regulator assembly with valves (H).
11. Remove the pressure regulator assembly with valves (H).
12. At the workbench, remove the fitting (I) from the fitting (J).
13. Unscrew the fitting (J) from the pressure regulator (K).
14. If necessary, unscrew the fittings (L) and (M) from the pressure regulator (K).
15. Retrieve the pressure regulator (K).

Assembly

16. Assemble the components in the reverse order of disassembly.
17. Perform the LPG System Leakage Check (see the procedure in LPG System Leakage Check paragraph).
18. If a new pressure regulator has been installed, adjust the CO₂ (see the procedure in “CO₂ Adjustment”).

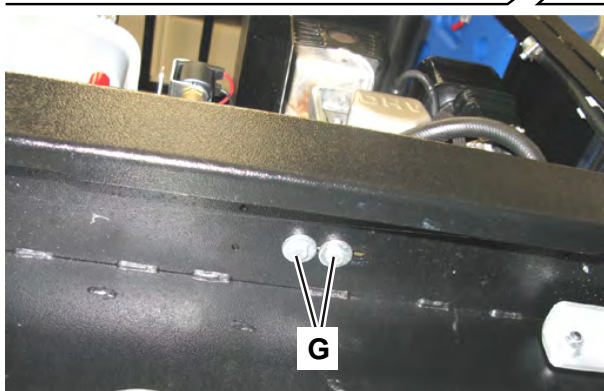
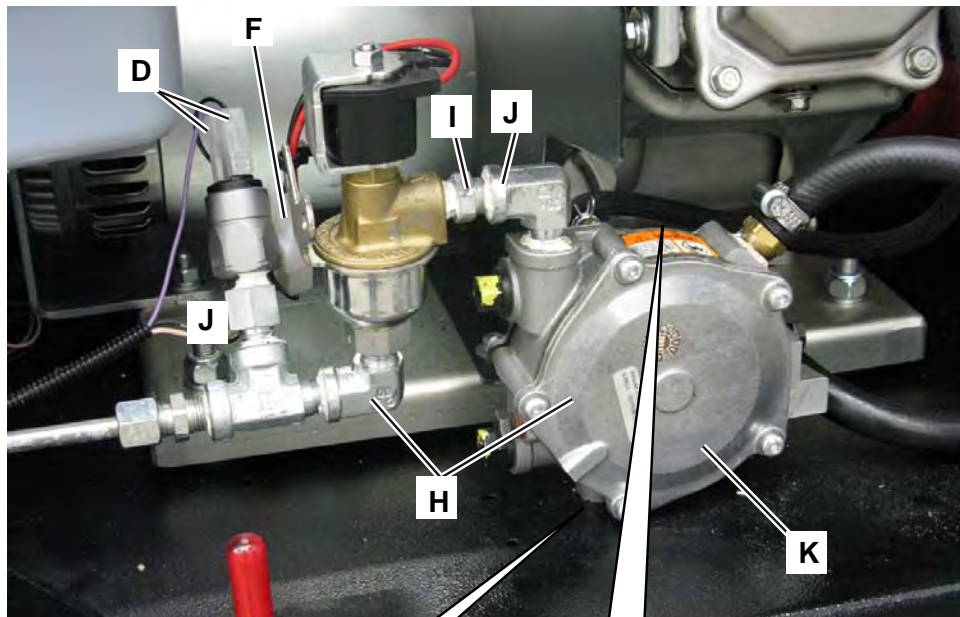

Pressure Valve Removal/Installation



Warning! *This procedure has to be performed by personnel qualified to handle the LPG systems, according to the law in force. Moreover, it is necessary to wear accident-prevention clothes, according to the law in force (heavy gloves, antistatic non-synthetic clothes, suitable to cover the whole body, antistatic and antispark shoes, helmets with visor; etc.).*

Disassembly

1. Empty the LPG system (see the procedure in “LPG System Emptying”).
2. Turn the ignition key to “0” and engage the parking brake.
3. Open the engine compartment hood with the handle and fasten it with the support rod.
4. Remove the machine right body side, by lifting it to disengage it from the fasteners.
5. Turn the fasteners and remove the machine right door.
6. If the engine is hot, wait that it cools down.
7. Disconnect the electrical connections (A).
8. Unscrew the pressure valve (B) while holding the fitting (C).



Caution! *For disassembly/assembly of the various hoses and fittings of the LPG system, refer to the procedure in “LPG System Hose and Fitting Disassembly/Assembly”.*

Assembly

9. Assemble the components in the reverse order of disassembly.
10. Perform the LPG System Leakage Check (see the procedure in LPG System Leakage Check paragraph).

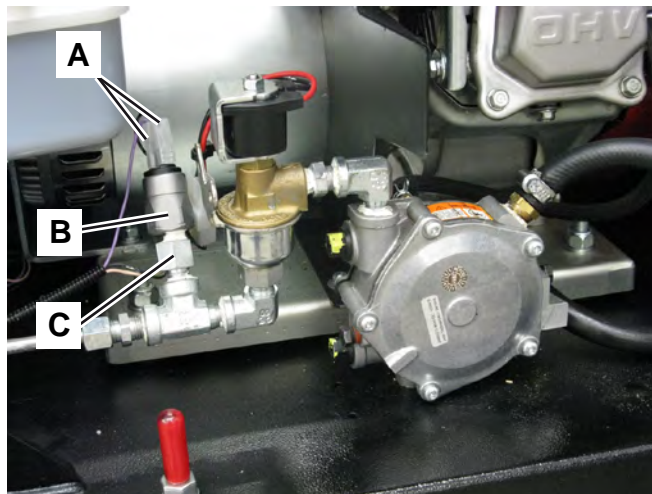

Solenoid Valve Removal/Installation



Warning! *This procedure has to be performed by personnel qualified to handle the LPG systems, according to the law in force. Moreover, it is necessary to wear accident-prevention clothes, according to the law in force (heavy gloves, antistatic non-synthetic clothes, suitable to cover the whole body, antistatic and antispark shoes, helmets with visor; etc.).*

Disassembly

1. Empty the LPG system (see the procedure in “LPG System Emptying”).
2. Turn the ignition key to “0” and engage the parking brake.
3. Open the engine compartment hood with the handle and fasten it with the support rod.
4. Remove the machine right body side, by lifting it to disengage it from the fasteners.
5. Turn the fasteners and remove the machine right door.
6. If the engine is hot, wait that it cools down.
7. Unscrew the fitting (A).



Caution! *For disassembly/assembly of the various hoses and fittings of the LPG system, refer to the procedure in “LPG System Hose and Fitting Disassembly/Assembly”.*

8. Loosen the retaining bands (B) and disconnect the hoses (C).

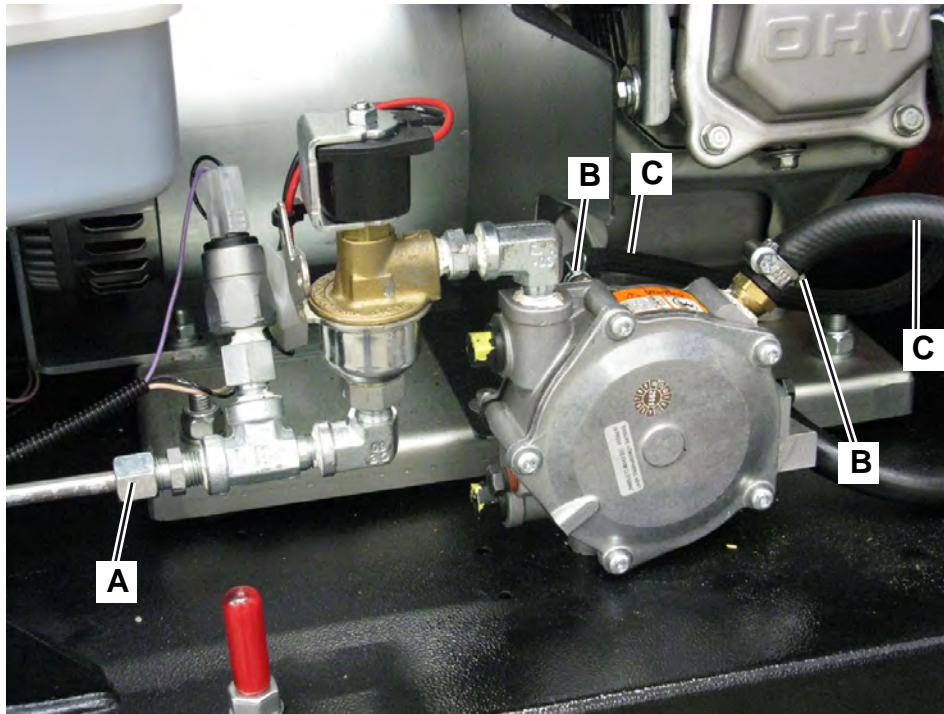

Solenoid Valve Removal/Installation (Continues)

9. Disconnect the electrical connections (D) and (F).
10. Remove the fastening screws (G) of the pressure regulator assembly with valves (H).
11. Remove the pressure regulator assembly with valves (H).
12. At the workbench, remove the “T” fitting (I) from the fitting (L).
13. Remove the solenoid valve (J) from the fitting (K).
14. Unscrew the fitting (L) from the solenoid valve (J).
15. Retrieve the solenoid valve (J).

Assembly

16. Assemble the components in the reverse order of disassembly.
17. Perform the LPG System Leakage Check (see the procedure in LPG System Leakage Check paragraph).

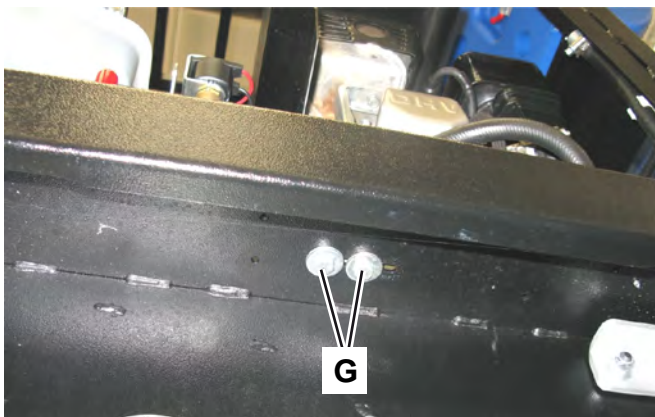
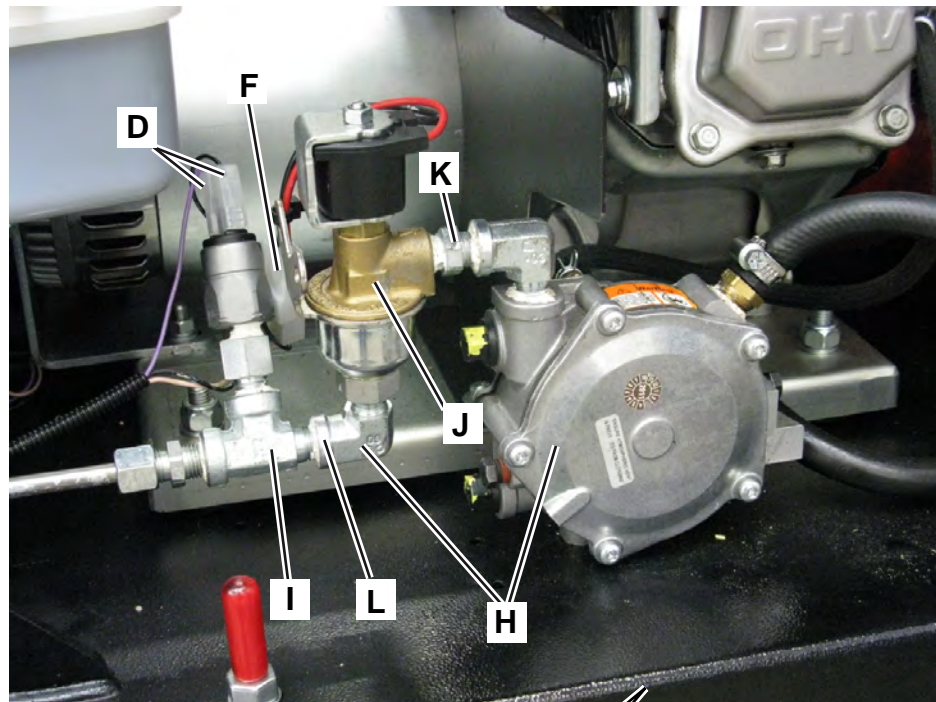

Engine-Dynamotor Unit Disassembly/Assembly

Disassembly

1. Empty the LPG system (see the procedure in “LPG System Emptying”).
2. Drive the machine on a level floor.
3. Turn the ignition key to “0” and engage the parking brake.
4. Open the engine compartment hood with the handle and fasten it with the support rod.
5. Disconnect the batteries.
6. Remove the machine right body side (A), by lifting it to disengage it from the fasteners.
7. Disconnect the LPG hose (B) from the carburettor (C), as shown in “LPG System Hose and Fitting Disassembly/Assembly LPG”.

Close with sealing plugs the disconnected fittings to prevent foreign materials from entering into the system.

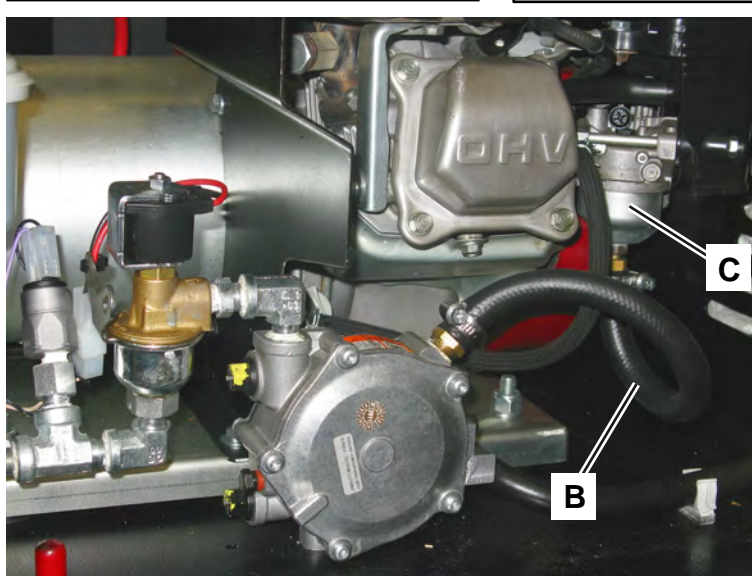
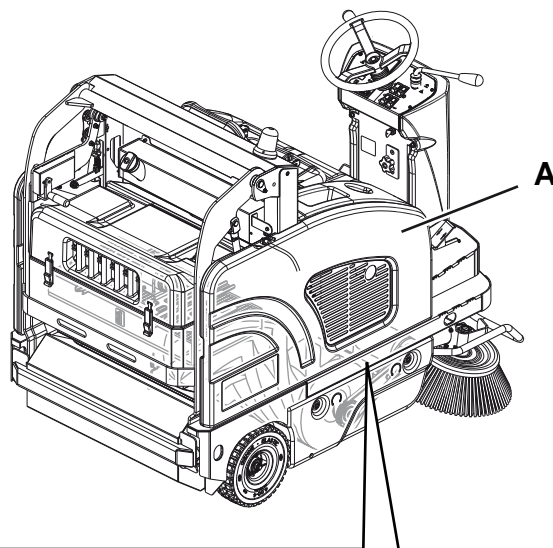

Engine-Dynamotor Unit Disassembly/Assembly (Continues)

8. Disconnect the wiring harnesses (F) of the dynamotor (G) from the electrical cable (H) and the batteries (I) (mark each position for proper reassembly).
9. Disconnect the engine start electrical connector (J).
10. Disconnect the engine ground (K).
11. Remove the four fastening nuts (L) of the engine holder (M).
12. Remove the fastening screws and then remove the case (N).
13. Disengage the engine oil drain hose (P), from the fastening clamps (Q).
14. Place a proper and safe lifting belt (R) transversally on the flange (S), as shown in the figure (the belt (R) have to slide smoothly along the dynamotor).
15. With a proper hoisting system, carefully lift the dynamotor assembly and let it swing slightly to avoid the obstacles (Weight of the engine-dynamotor unit: 40 kg)

Assembly

16. Assemble the components in the reverse order of disassembly.

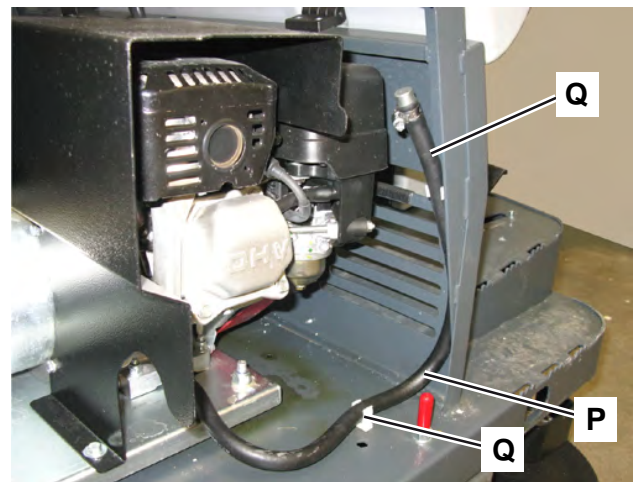
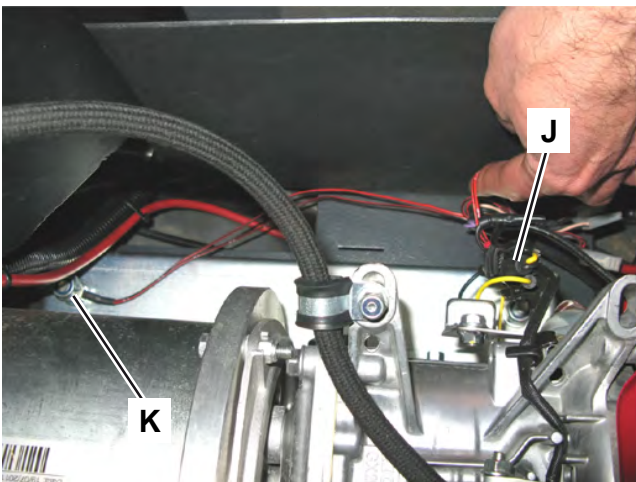
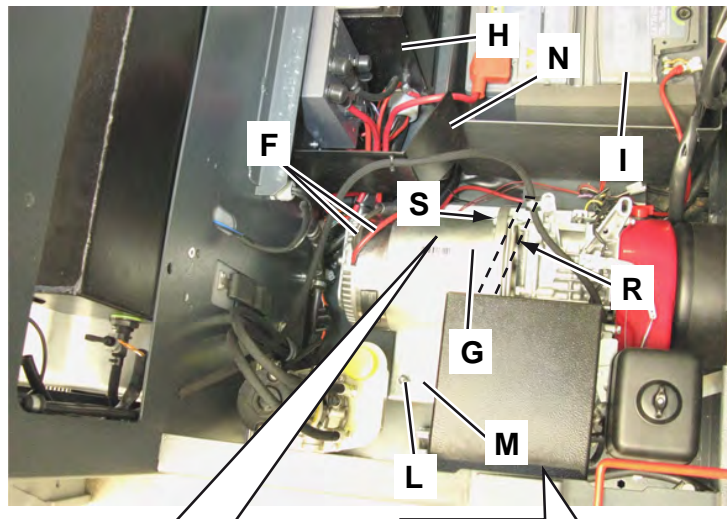

Engine Unit Disassembly/Assembly

Disassembly

1. Remove the engine-dynamotor unit (see the procedure in the previous paragraph).
2. Remove the dynamotor unit (see the procedure in Electrical System paragraph).
3. Remove the screws (A) and separate the engine assembly (B) from the holder (C). Engine weight: 24 kg approx.
4. If necessary, unscrew the three screws (D) and remove the air deflector (E) from the engine.

Assembly

5. Assemble the components in the reverse order of disassembly.

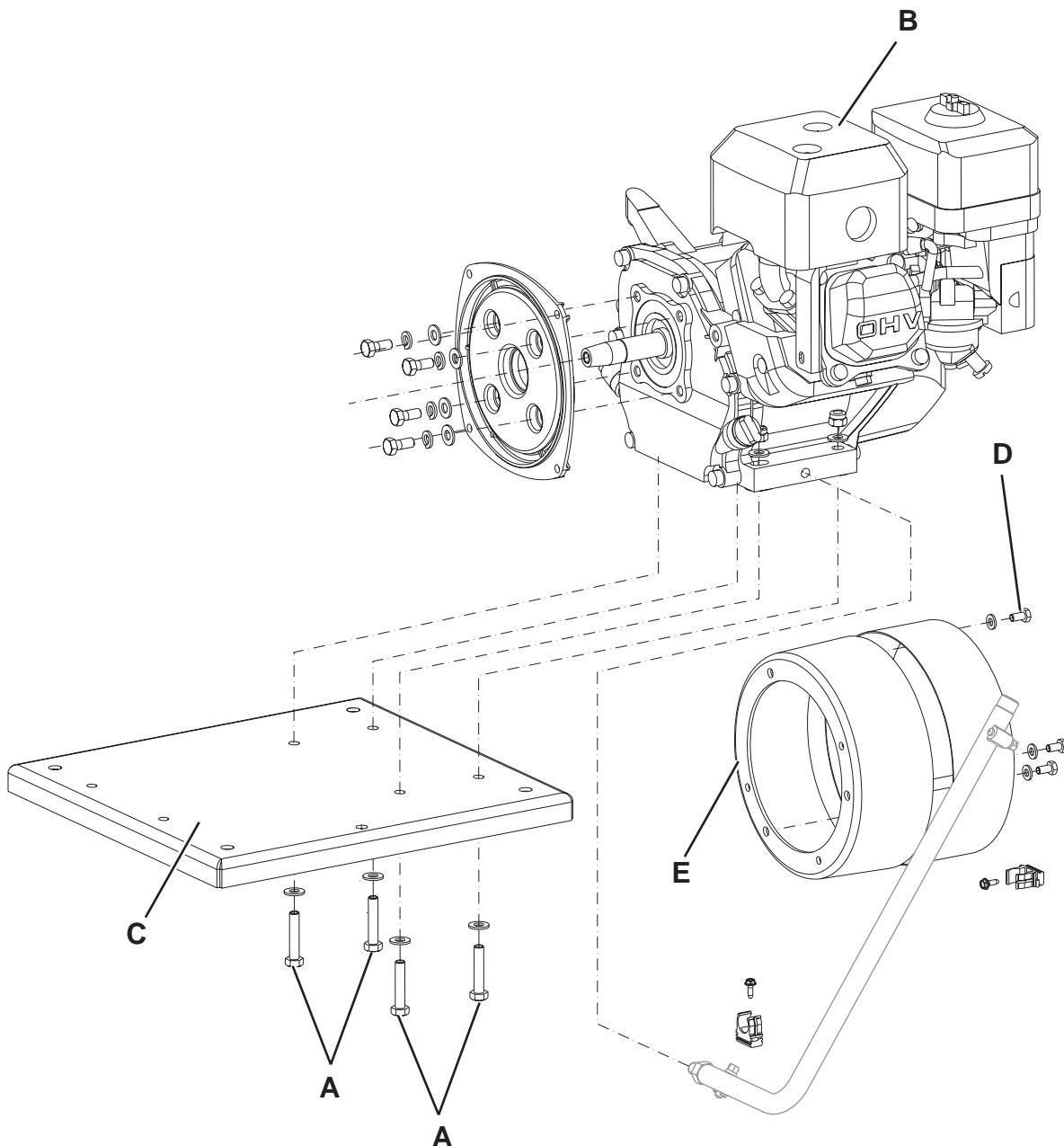

Specifications

Engine System - LPG	Values
	SW4000 LPG
Make	Honda
Model	GX-200
Regulated power (ISO 1585)	6.7 kW
Working speed	2,750 ± 50 rpm
Oil type	SAE 5 W 30 - SYNTHETIC API SJ
Reserve	17.4 psi (1.2 Bar)
Length Width Height (engine only)	12.3 x 14.8 x 13.2 in (313 x 376 x 335 mm)
Displacement (bore x stroke)	12 in ³ [2.68 x 2.13 in] (196 cm ³ [68 x 54 mm])
Maximum output	4.8 kW (6.5 PS) at 3,600 min (rpm)
Max torque	117 lbf in - 2,500 rpm (min) (13.2 N•m (1.35 kgf•m) at 2,500 min (rpm))
Engine oil quantity	0.16 gal US (0.60 liters)
Cooling system	Forced air
Starting system	Transistor magnet
PTO shaft rotation	Counter-clockwise
Distance between the spark plug electrodes	0.028 - 0.031 in (0.70 - 0.80 mm)
Idle speed	1,400 min (rpm)
Valve clearance (cold)	INTAKE: 0.15 ± 0.02 mm EXHAUST: 0.20/0.02 mm
Fuel	LPG tank
Spark plug	BPR6ES (NGK) W20EPR-U (DENSO)

Hopper System

Functional Description

The hopper lifting system is operated by an hydraulic cylinder driven by an electric pump motor (M3) with integrated hydraulic unit.

The pump motor (M3) is powered by 2 relays (K3A) and (K3B), driven respectively for hopper lifting and lowering. The pump is protected by the fuse (F6).

The relays are driven by the hopper movement enabling switch (SW4) and by the hopper lifting/lowering switch (SW5).

To lift or lower the hopper is essential to simultaneously operate both switches.

This may create a potential hazard to people who might be near the arm system and hopper while moving.

When the hopper comes out of its rest position, the position sensor (S1) provides its signal to the dashboard electronic board (EB2) and to the drive system electronic board (EB1) in order to obtain the following automatic functions: Reduction of machine maximum speed (by EB1 electronic board), activation of the buzzer (BZ1) and hopper lifting warning light (A), switching off of the vacuum system motor (M1) and of the broom motors (M4, M6, M7) (by EB2 electronic board).

At different heights of the lifting system, the release lever for hopper dumping can be activated.

The lever, by means of a metal cable, controls a rod which opens the locking system and releases the telescopic arm thus allowing the hopper to rotate and dump.

Once the hopper is turned for dumping, it can be shaken or engaged back to its position by using the hopper manual returning handle. If it is not manually engaged, it engages automatically when the hopper returns to the rest position (closed).

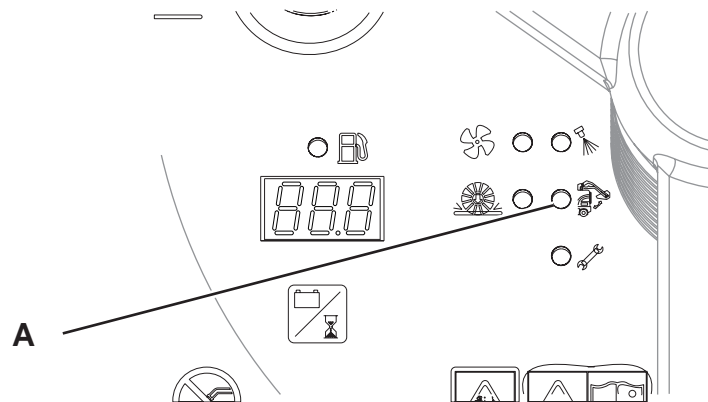

P200246

Wiring Diagram

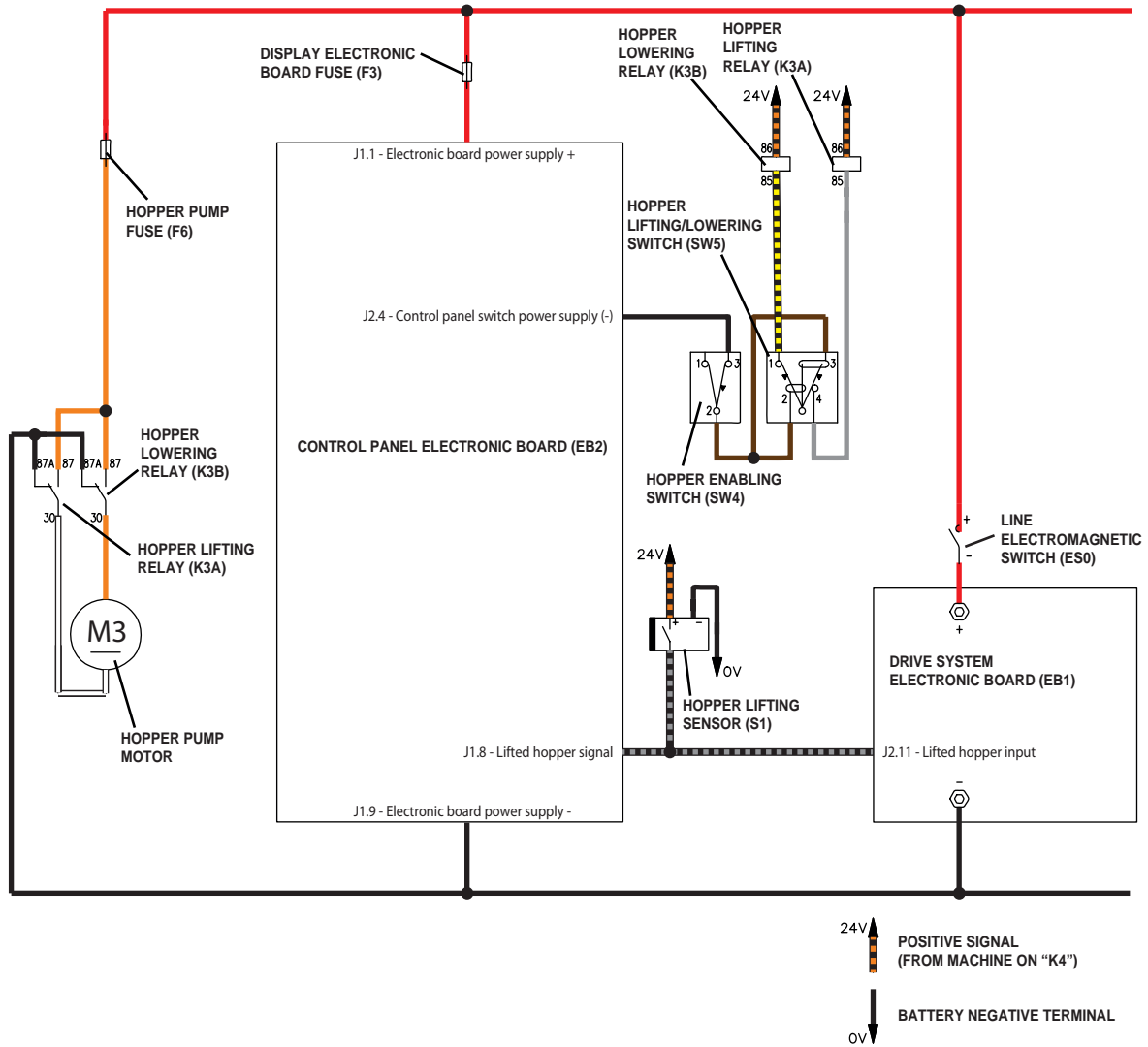

Hydraulic diagram

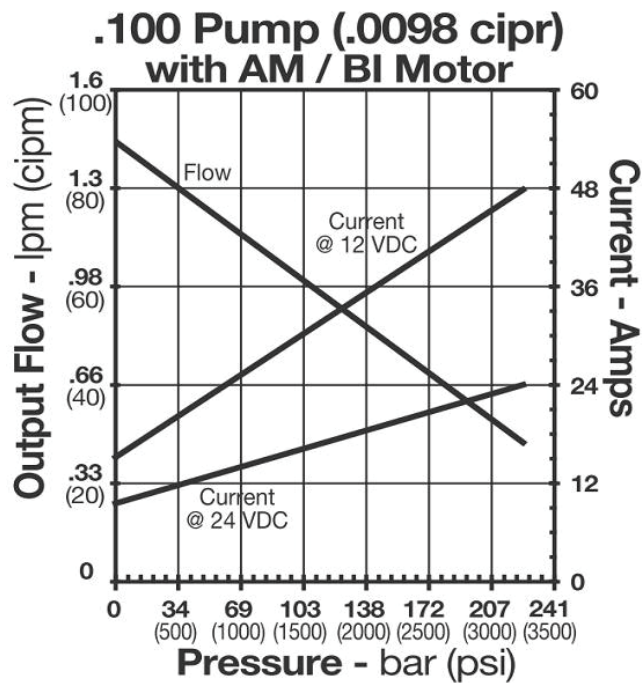
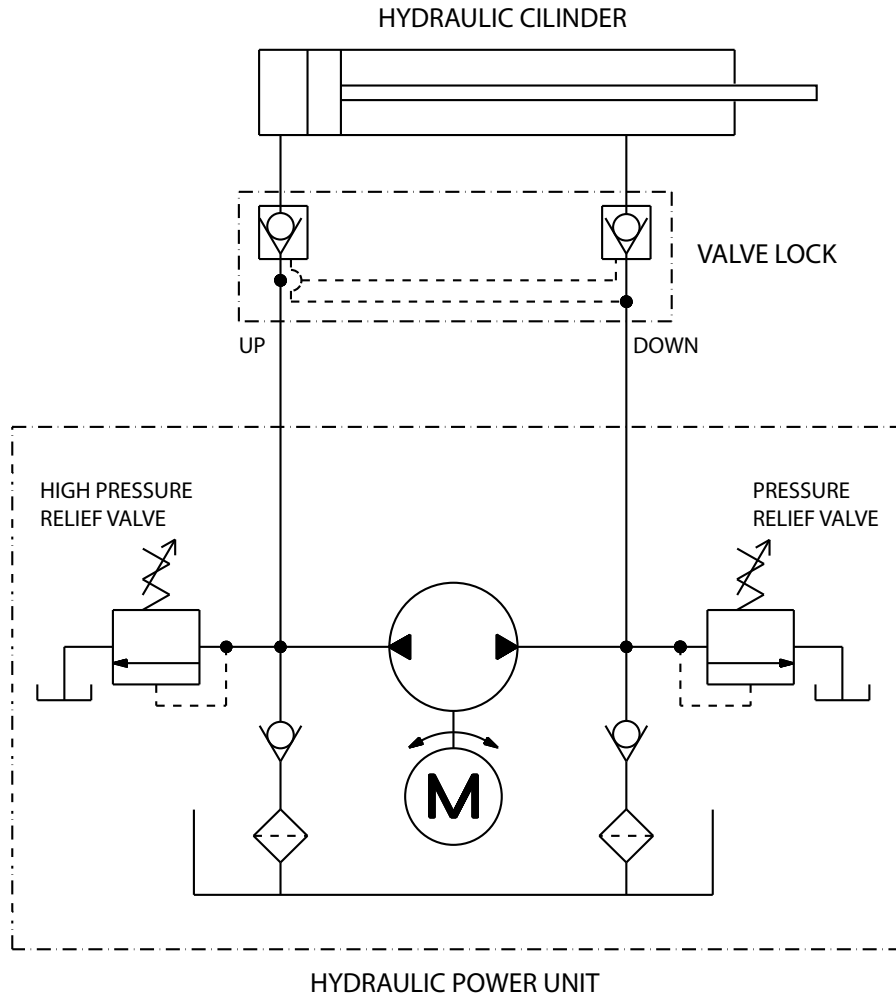

Component Locations

- Hopper lifting system warning light
- Hopper movement enabling switch (SW4)
- Hopper lifting/lowering switch (SW5)
- Closed hopper sensor (S1)
- Hopper linkages
- Hopper

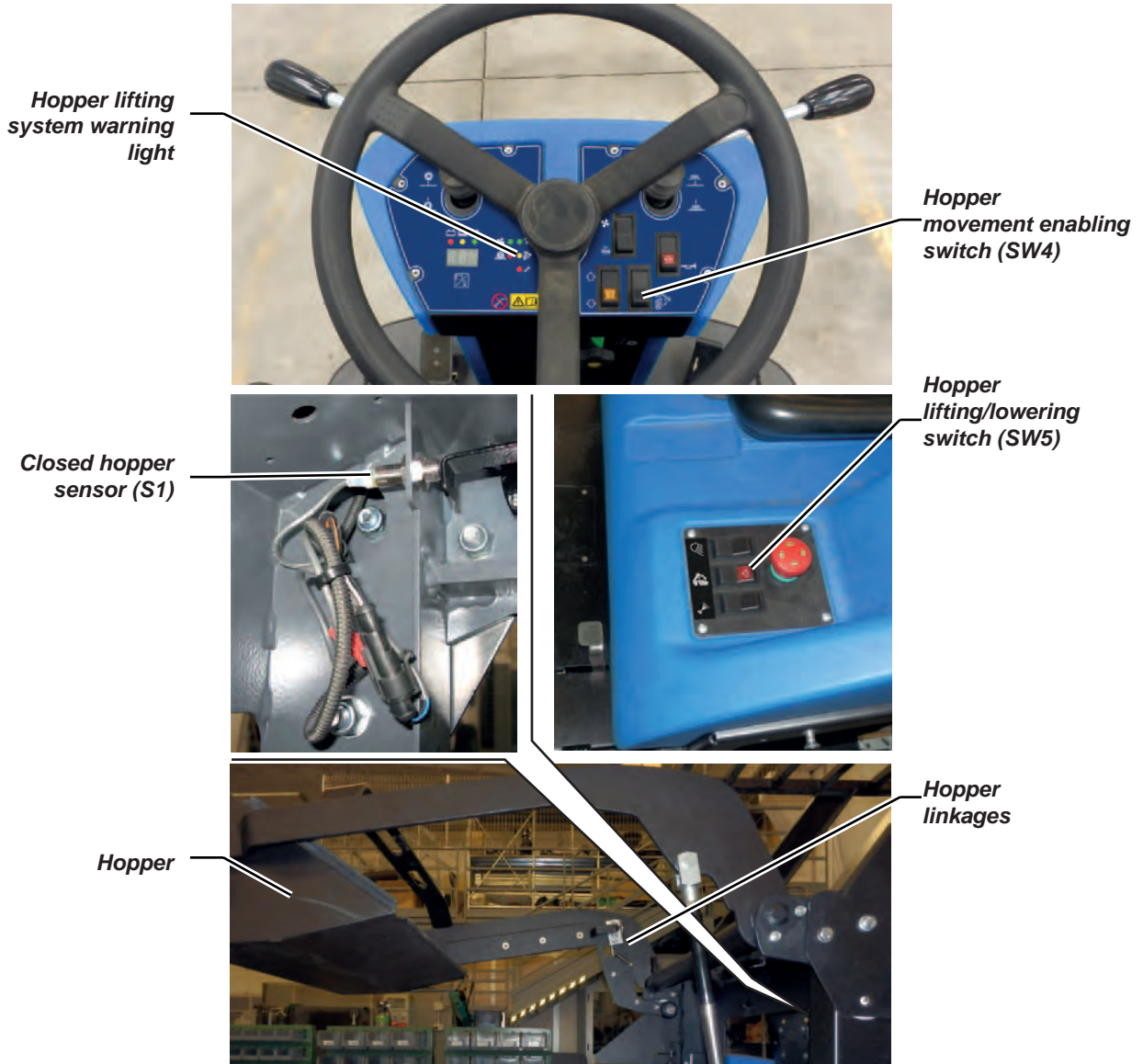

Component Locations (Continues)

- Check valve
- Hydraulic hoses
- Hydraulic cylinder
- Hydraulic control unit
- Hydraulic oil tank
- Hopper lifting fuse (25 A - Battery) (30 A Petrol/LPG) (F6)

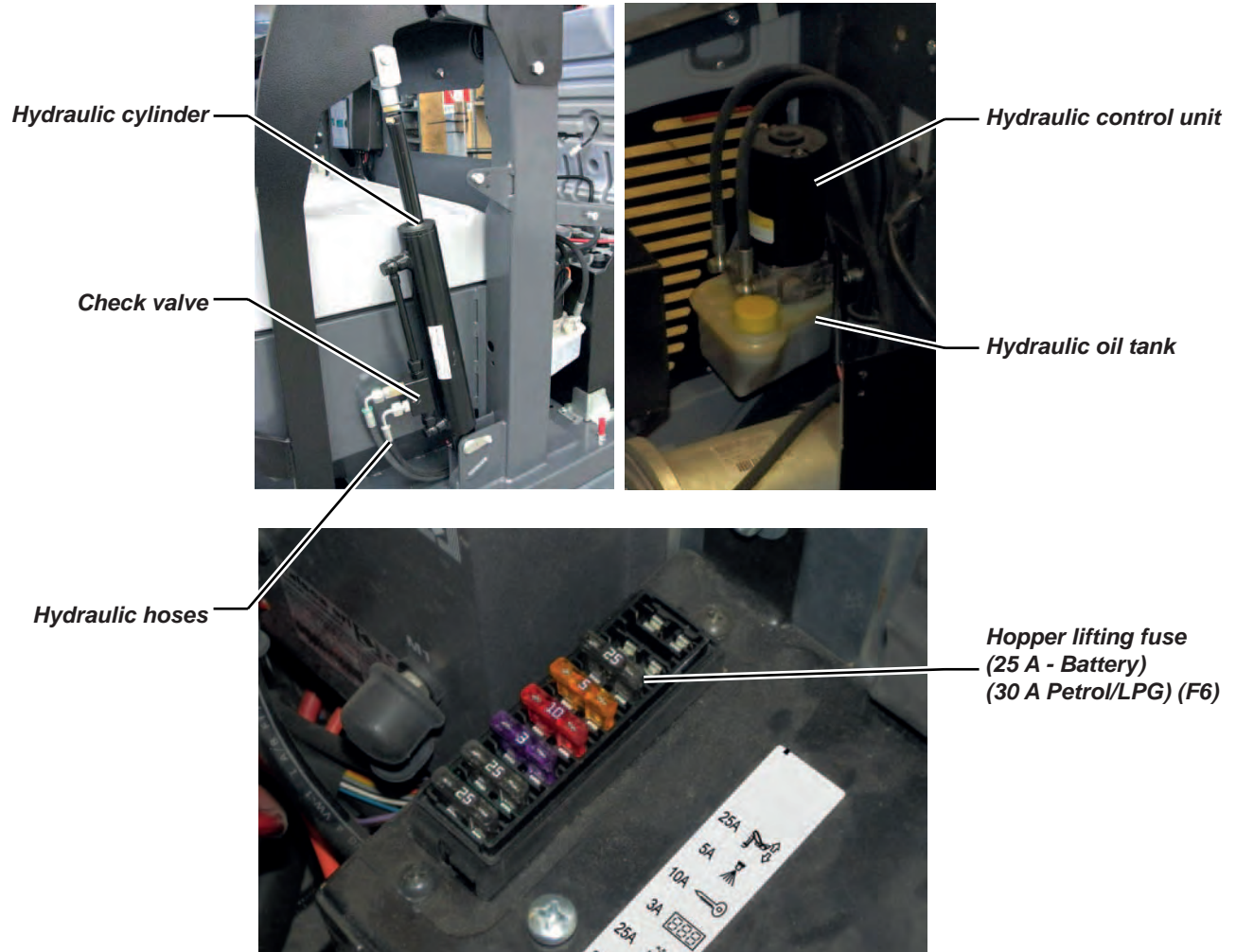

Maintenance and Adjustments

Hydraulic System Oil Level Check



Warning! Procedure to be performed with the hopper fully retracted.

1. Turn the ignition key to “0” and engage the parking brake.
2. Open the battery/engine compartment hood with the handle and fasten it with the support rod.
3. (Only for SW4000 Battery, with battery box). Remove the machine right body side (A), by lifting it to disengage it from the fasteners.
4. Check that the oil level in the hydraulic unit tank is between the minimum (MIN) (B) and maximum (MAX) (C) marks shown.
5. If necessary, add oil through the plug (D); use the oil specified in Technical Data paragraph.



Warning! Hydraulic system oil is highly corrosive.



Warning! The hydraulic system oil should be disposed of properly according to the Law in force.

6. (Only for SW4000 Battery, with battery box). Install the right body side (A) and engage it with the fasteners.
7. Remove the support rod and close the battery/engine hood.

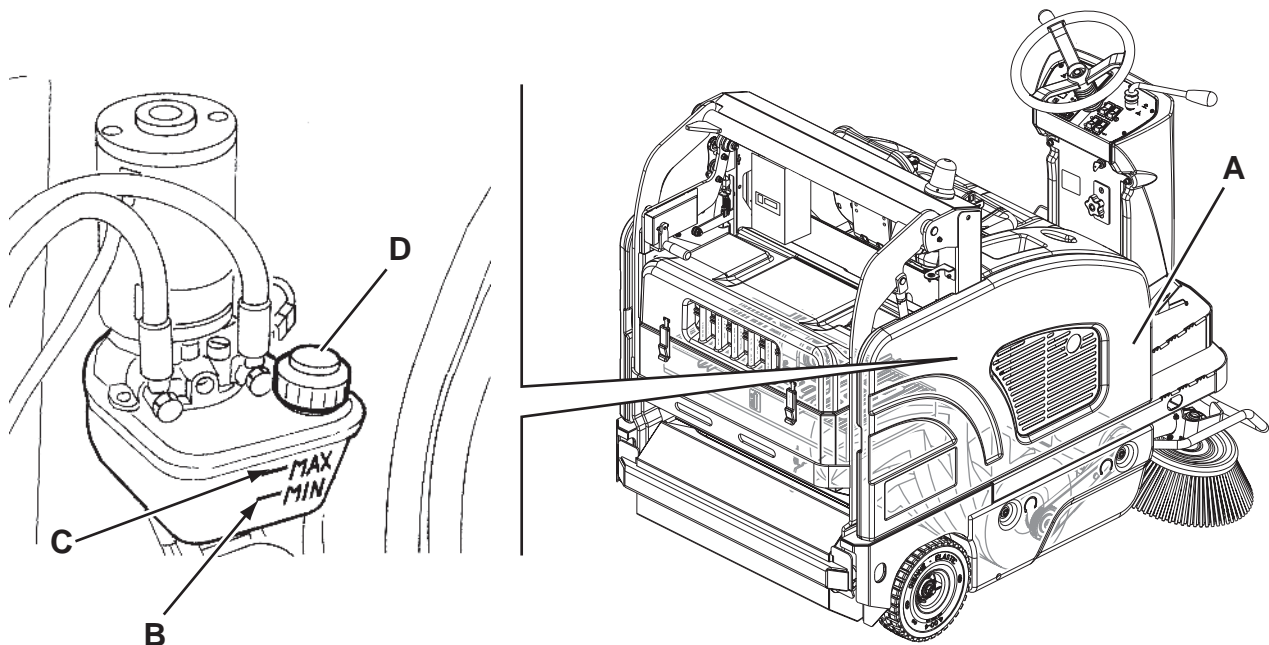

Troubleshooting

Trouble	Possible causes	Remedy
The hopper does not lift.	The fuse (F6) is open.	Replace the fuse.
The hopper does not dump.	The hopper is too low.	Lift the hopper at a minimum height of 350 mm.
The hopper does not give a signal of being closed.	The sensor (S1) is misadjusted or broken.	Adjust/replace
The hopper does not lift.	The hydraulic system oil level is incorrect.	Check the hydraulic system oil level in the tank.
The hopper does not lower.	In case of low temperatures, the hydraulic system oil is slow in flowing through the safety valve.	Wait a few moments to let the hydraulic system oil flow.

Removal and Installation

Closed Hopper Sensor Disassembly/Assembly and Adjustment

Disassembly

1. Drive the machine on a level floor.
2. Turn the ignition key to “0” and engage the parking brake.
3. Open the battery/engine compartment hood with the handle and fasten it with the support rod.
Disconnect the battery connector (SW4000 Battery) - Disconnect the batteries (SW4000 Petrol/LPG).
4. On the right rear upper side of the machine, remove the connector (B) of the closed hopper sensor (C) from its housing (A).
5. Cut the fastening clamp (D) and disconnect the connector (B).
6. Remove the locknut (E) and remove the sensor (C) with the wiring harness.

Assembly

7. Assemble the components in the reverse order of disassembly, and note the following:
 - Adjust the distance (F) between the sensor (C) and the bracket (G) at 4-5 mm, then tighten the locknut (E).

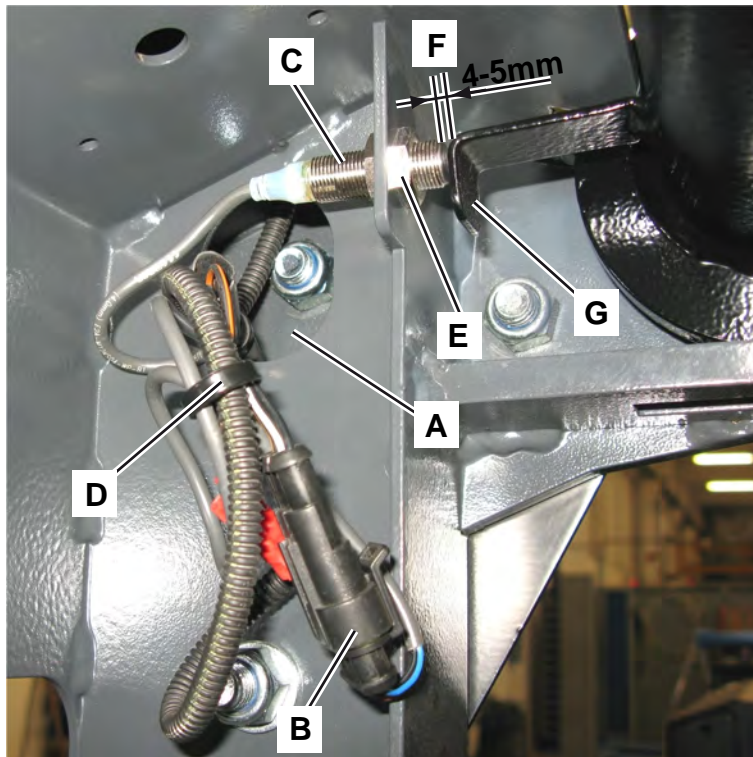

Hopper Disassembly/Assembly

Disassembly

1. Empty the hopper.
2. Drive the machine on a level floor.
3. Engage the parking brake.
4. Operating on the machine controls, as shown in the User Manual, lift the hopper (A), then lower it by laying it on a wide holder (B), as shown in the figure (to safely support it during the disassembly).
5. Turn the ignition key to “0”.
6. On the left side of the hopper (A), remove the screw (C) and retrieve the components (D).
7. Turn the lever (E) to rest position.
8. The side flange (F) for hopper adjustment must be left in its original position. If necessary, it will be adjusted after the hopper reassembly.
9. Remove the two screws (G) on both sides of the hopper (A) and retrieve the components (H).
10. Remove the hopper (A) by disengaging the lifting arms (I) with the lever.

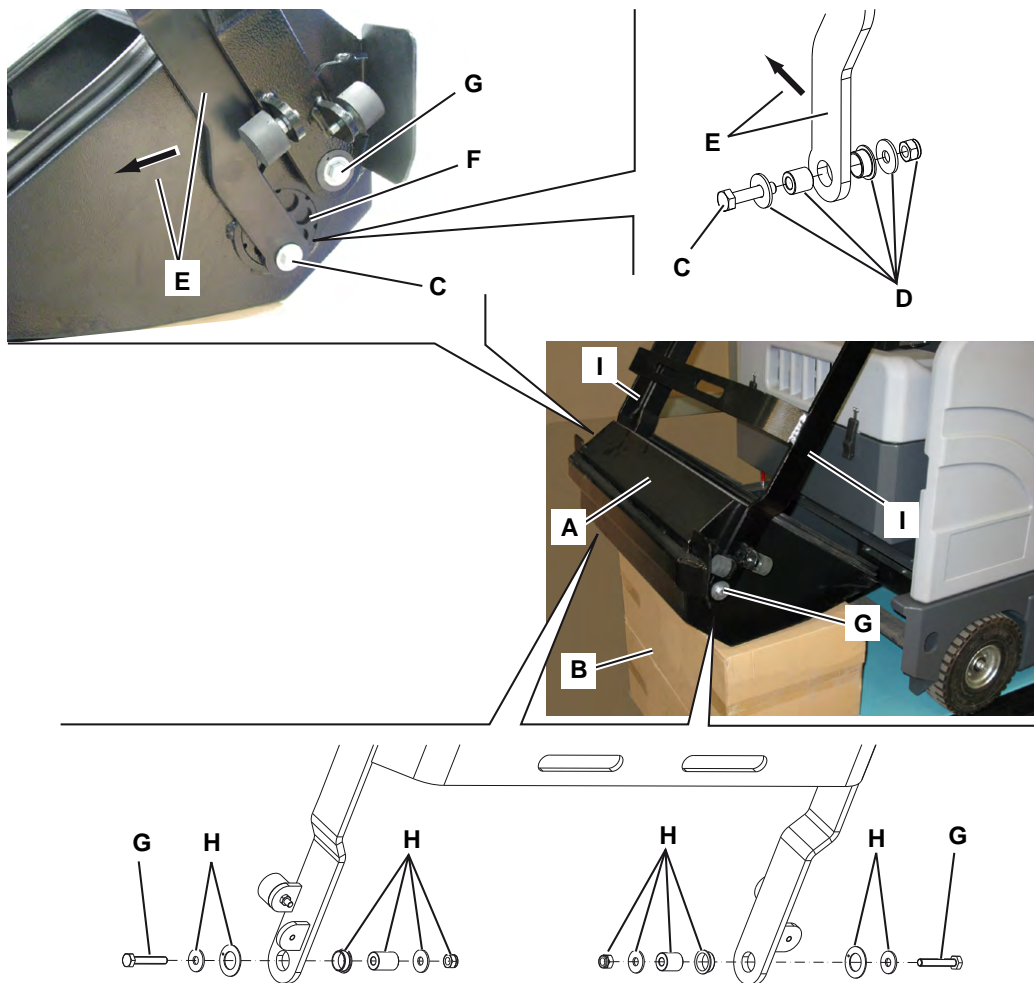

Hopper Disassembly/Assembly (Continues)

Assembly

11. Assemble the components in the reverse order of disassembly.
12. Check that the hopper operates properly and that it is properly aligned; if necessary align it as shown below.

Alignment Adjustment

- To allow for a proper vacuuming capacity it is necessary that, when the hopper (A) is closed, all the perimeter of its gasket (J) is sticks to the chassis (K) of the machine. If this condition is not satisfied because the hopper and machine chassis are misaligned, these must be aligned with the side flange (F), as shown below.
13. The standard assembly of the flange (F) is performed by placing the “V” groove (L) at “6 o’clock”, thus engaging the notch (M) on the tooth (N) of the hopper housing (A).
 14. To adjust the hopper alignment:
 - Perform steps 2 to 5.
 - Remove the screw (C) and retrieve the components (D).
 - Remove the screw (P) and remove the flange (F) from its housing, then insert it again after turning it as necessary to restore the alignment (each notch corresponds in negative or positive to 0.5 degrees, as shown on the flange itself).
 - Tighten the screw (P).
 - Assemble the components (D), on the flange (F) and tighten the screw (C).
 15. Removing the main broom and checking that there is no light passing through the seal and the chassis.
 16. Check that the hopper operates properly and that it is properly aligned; if necessary repeat the alignment procedure.

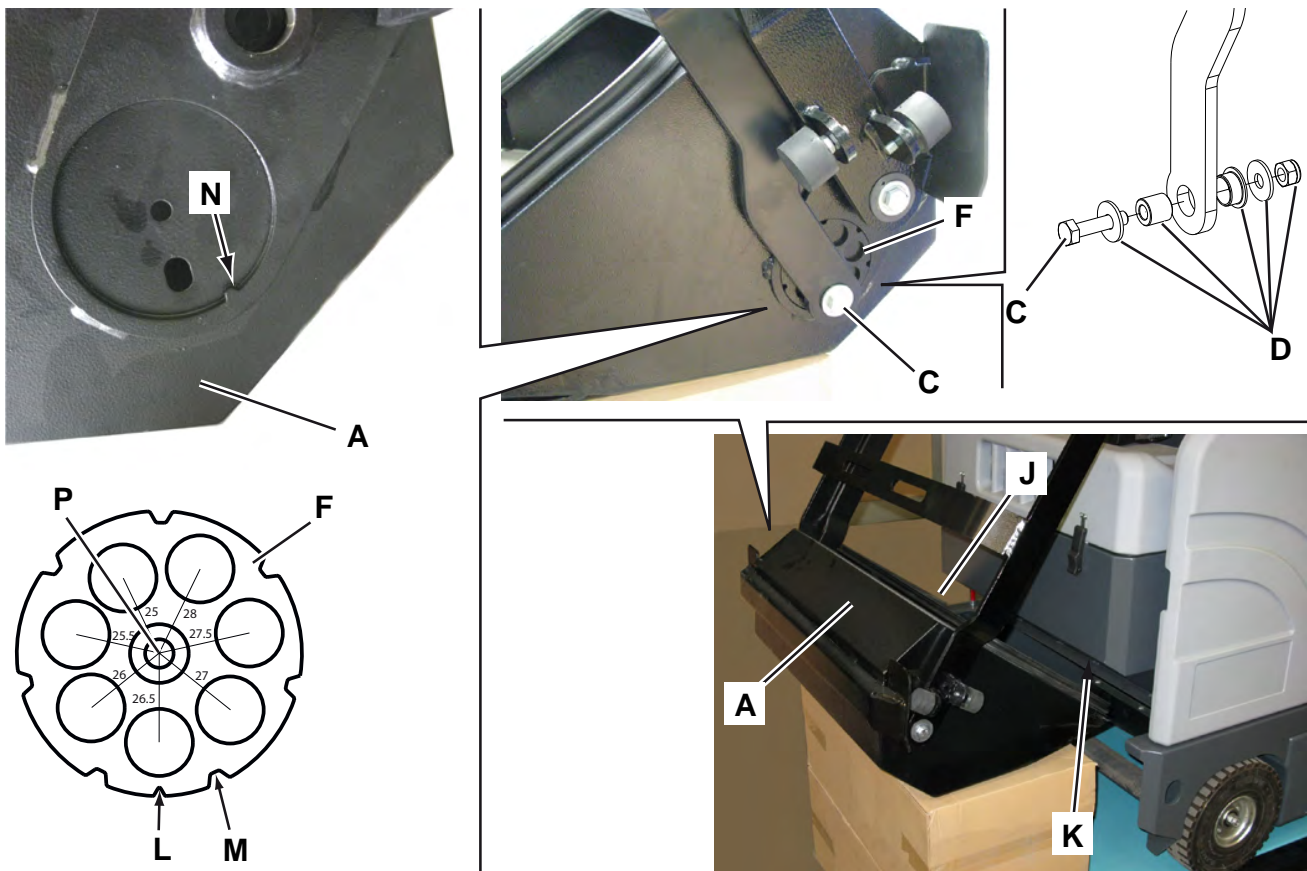

Hopper and Lifting Arm Disassembly/Assembly

Disassembly

1. Empty the hopper and then close it.
2. Drive the machine on a level floor.
3. Engage the parking brake.
4. Ensure that the hopper is closed.
5. On the upper area of the right hopper arm (A), remove the cotter pin and the pin (B).
6. Move the hydraulic cylinder rod (C) forward until it is flushed with the machine chassis.
7. On the upper area of the left hopper arm (D), remove the nut (E) and the screw (F), then retrieve the components (G).

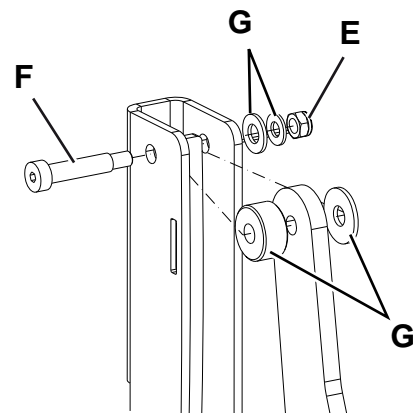
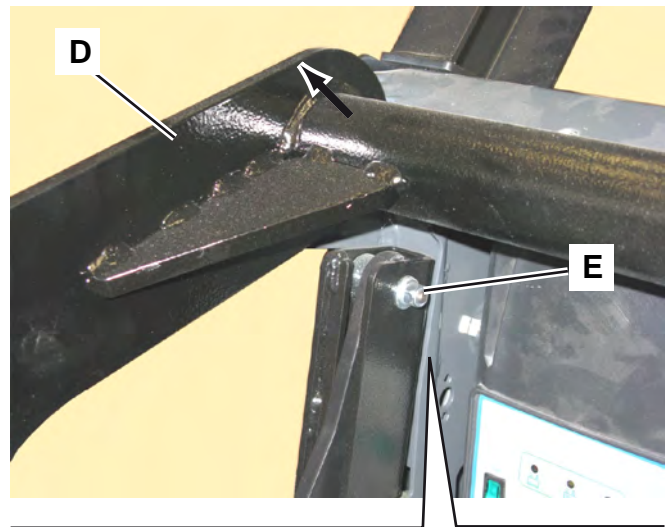
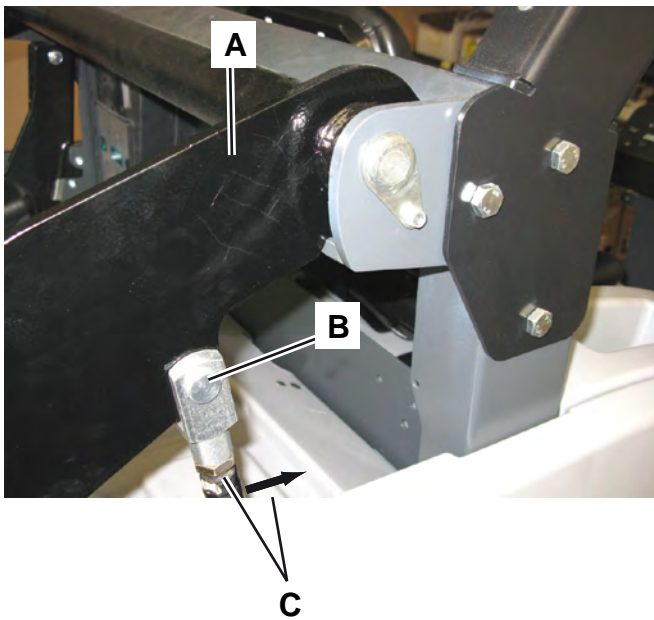

Hopper and Lifting Arm Disassembly/Assembly (Continues)

8. Apply a proper safety lifting rope (H) on the upper part of the hopper arms, as shown in the figure. (Hopper weight with lifting arms: 16 kg)
9. Remove the side screws (I) and remove the rotating pins (J).
10. With a proper hoisting system (K), remove the hopper with lifting arms (L), by moving it backwards and lifting it.

Assembly

Assemble the components in the reverse order of disassembly.

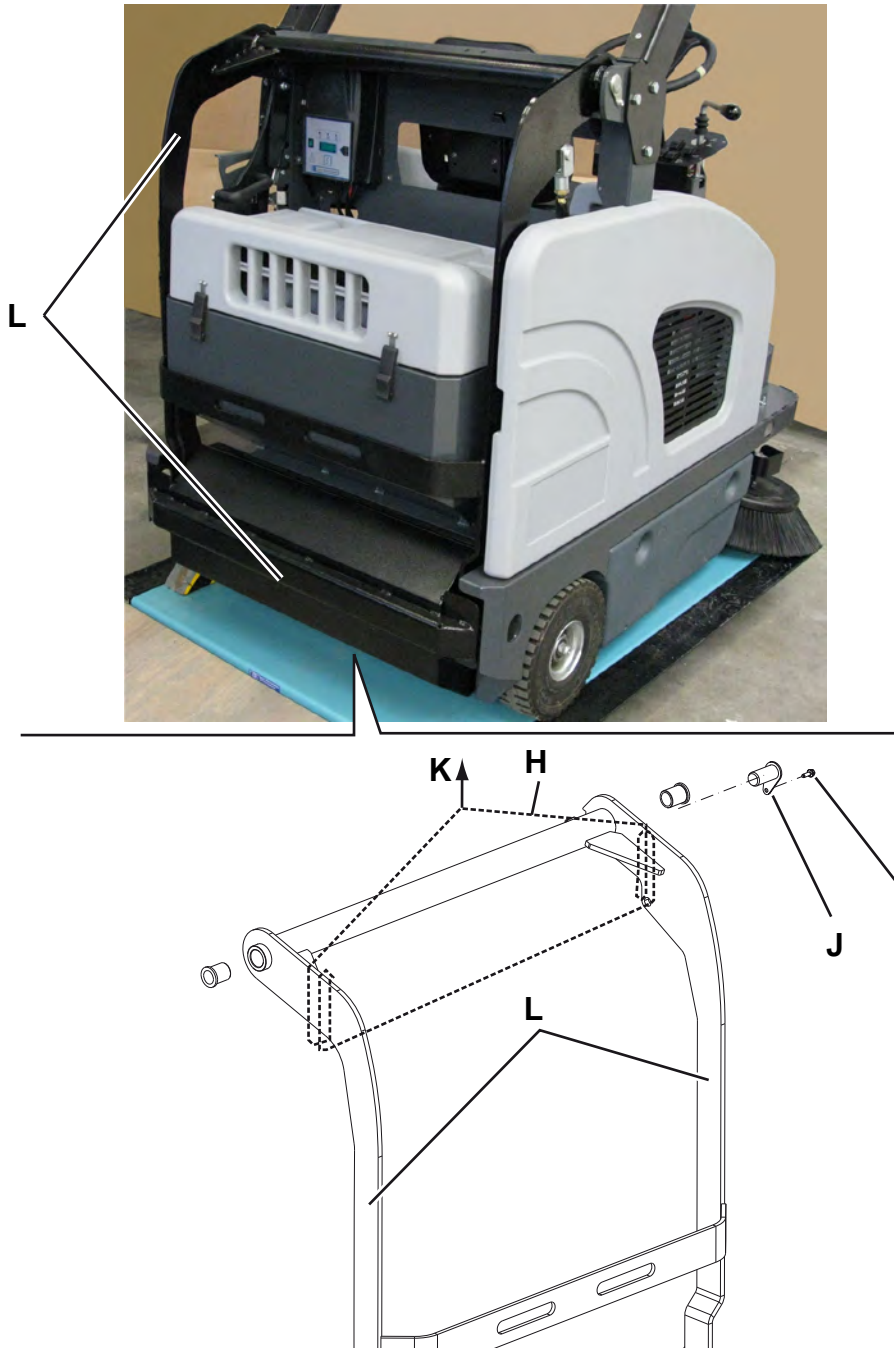

Hydraulic Control Unit Disassembly/Assembly

Disassembly

1. Drive the machine on a level floor.
2. Ensure that the hopper is closed.
3. Turn the ignition key to “0” and engage the parking brake.
4. Open the battery/engine compartment hood with the handle and fasten it with the support rod. Disconnect the battery connector (SW4000 Battery) - Disconnect the batteries (SW4000 Petrol/LPG).
5. Remove the machine right side bulkhead (A), by lifting it to disengage it from the fasteners.
6. Disconnect the vacuum system motor connector (B).
7. Disengage the retainers (C) and remove the vacuum system hood (D).

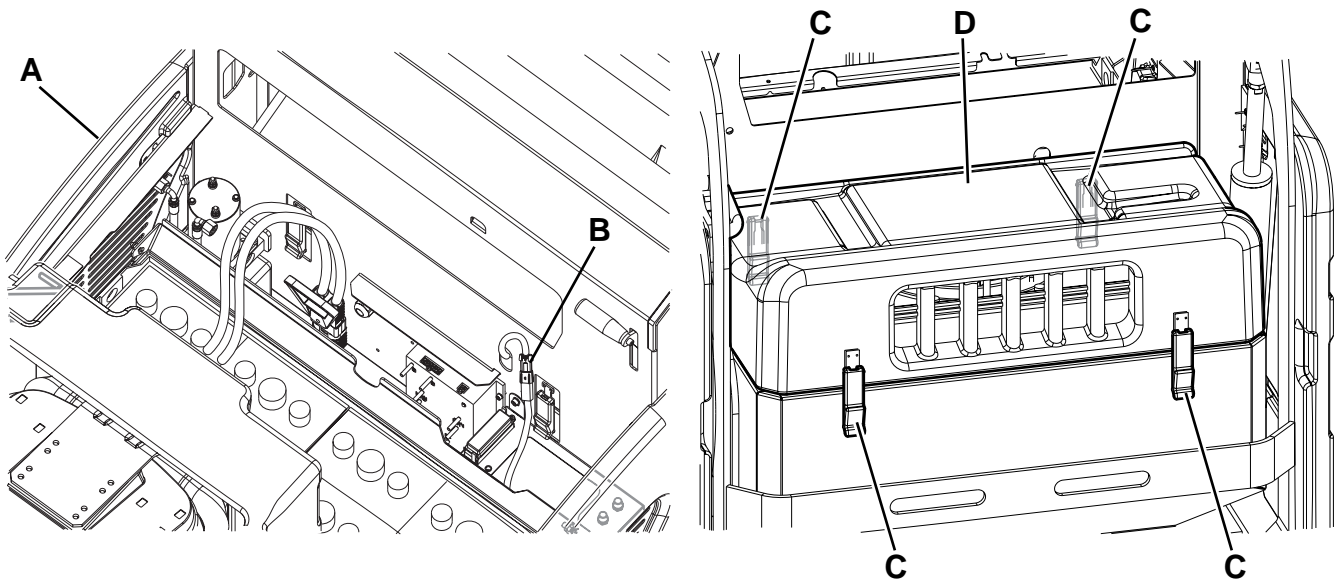

P200233

Hydraulic Control Unit Disassembly/Assembly (Continues)

8. Disconnect the electrical connector (E) of the hydraulic unit (F).
9. Remove the hollow screws (G) and disconnect the hydraulic hoses (H) from the hydraulic unit (F). Retrieve the gaskets (I).

If necessary, collect the hydraulic system oil in a proper container.

Plug the disconnected fittings, to prevent debris from entering into the hydraulic system.



Warning! Hydraulic system oil is highly corrosive.



Warning! The hydraulic system oil should be disposed of properly according to the Law in force.

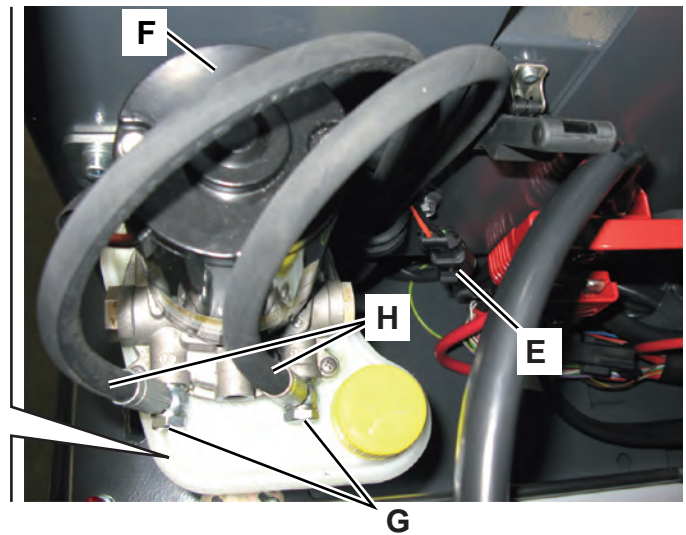
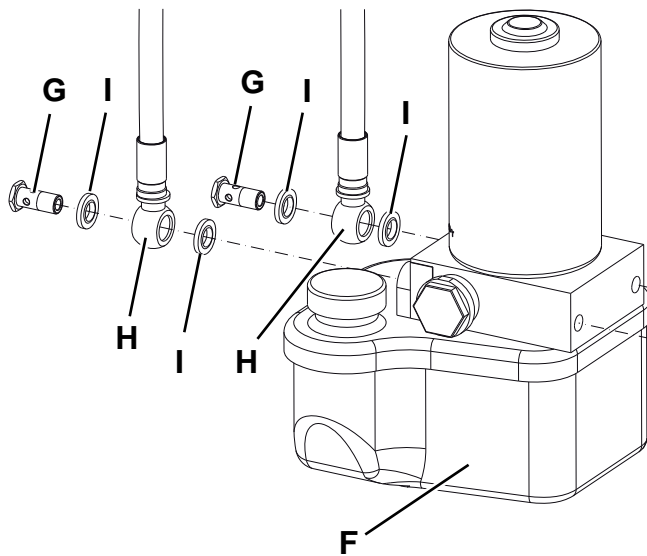

Hydraulic Control Unit Disassembly/Assembly (Continues)

10. Remove the front screw (J) and the rear screw (K) fastening the hydraulic unit (F).
11. Remove the hydraulic control unit (F).

Assembly

12. Assemble the components in the reverse order of disassembly, and note the following:
 - After the installation of the hydraulic unit (either the same unit or a new one), fill the tank with hydraulic oil up to the Max level, then run some hopper handling (the hydraulic system is self-bleeding); then, check the hydraulic system oil level.

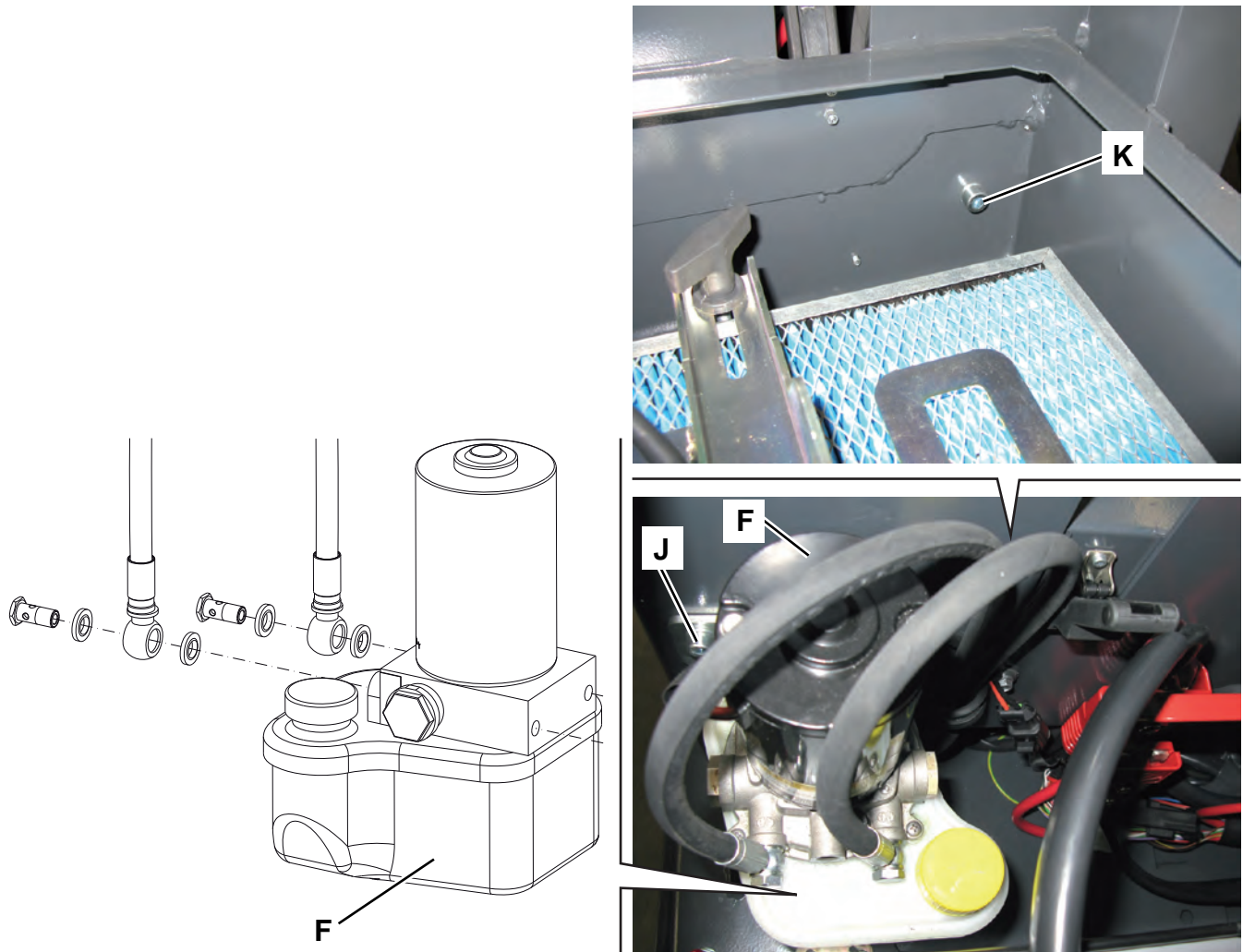

Hydraulic Hose Disassembly/Assembly

Disassembly

1. Drive the machine on a level floor.
2. Ensure that the hopper is closed.
3. Turn the ignition key to “0” and engage the parking brake.
4. Open the battery/engine compartment hood with the handle and fasten it with the support rod.
5. Remove the machine right side bulkhead, by lifting it to disengage it from the fasteners.
6. Remove the hollow screws (B) and disconnect the hydraulic hoses (C) from the hydraulic unit (D). Retrieve the gaskets (A).

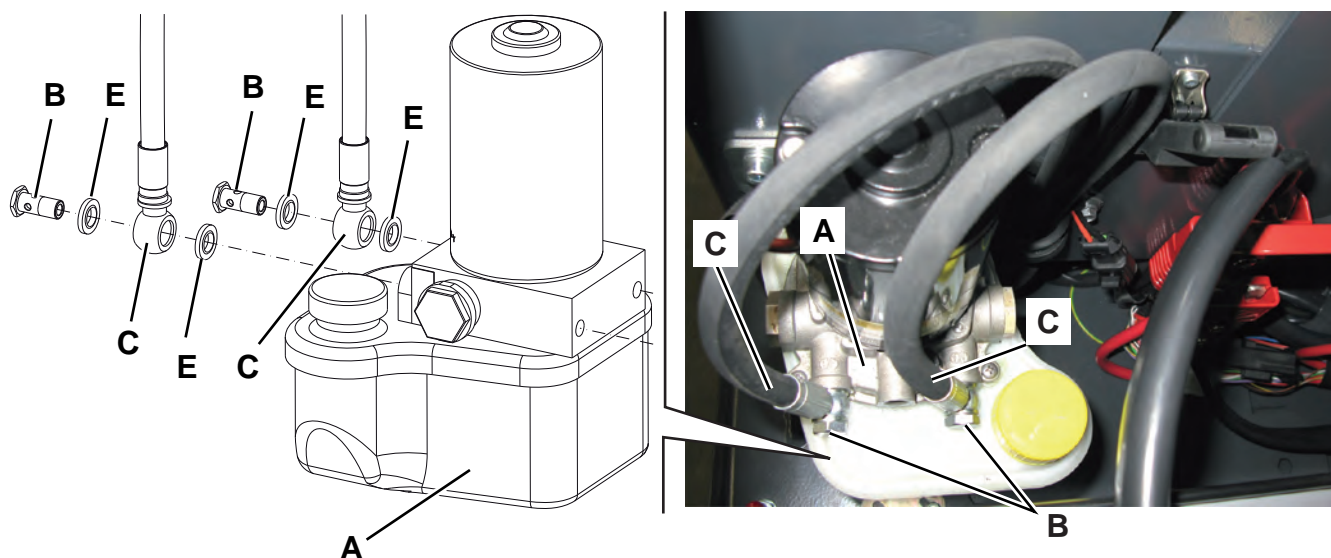

P200160

Hydraulic Hose Disassembly/Assembly (Continues)

Collect the hydraulic system oil in a proper container.

Plug the disconnected fittings, to prevent debris from entering into the hydraulic system.



Warning! *Hydraulic system oil is highly corrosive.*



Warning! *The hydraulic system oil should be disposed of properly according to the Law in force.*

7. Open the fastening clamps (F) and the hoses (C).
8. Unscrew the connecting fittings (G) of the hydraulic cylinder hoses (H).

Collect the hydraulic system oil in a proper container.

9. Retrieve the hydraulic hoses (C).

Assembly

10. Assemble the components in the reverse order of disassembly, and note the following:
 - After the installation of the hoses (either the same hoses or new ones), fill the tank with hydraulic oil up to the Max level, then run some hopper handling (the hydraulic system is self-bleeding); then, check the hydraulic system oil level.

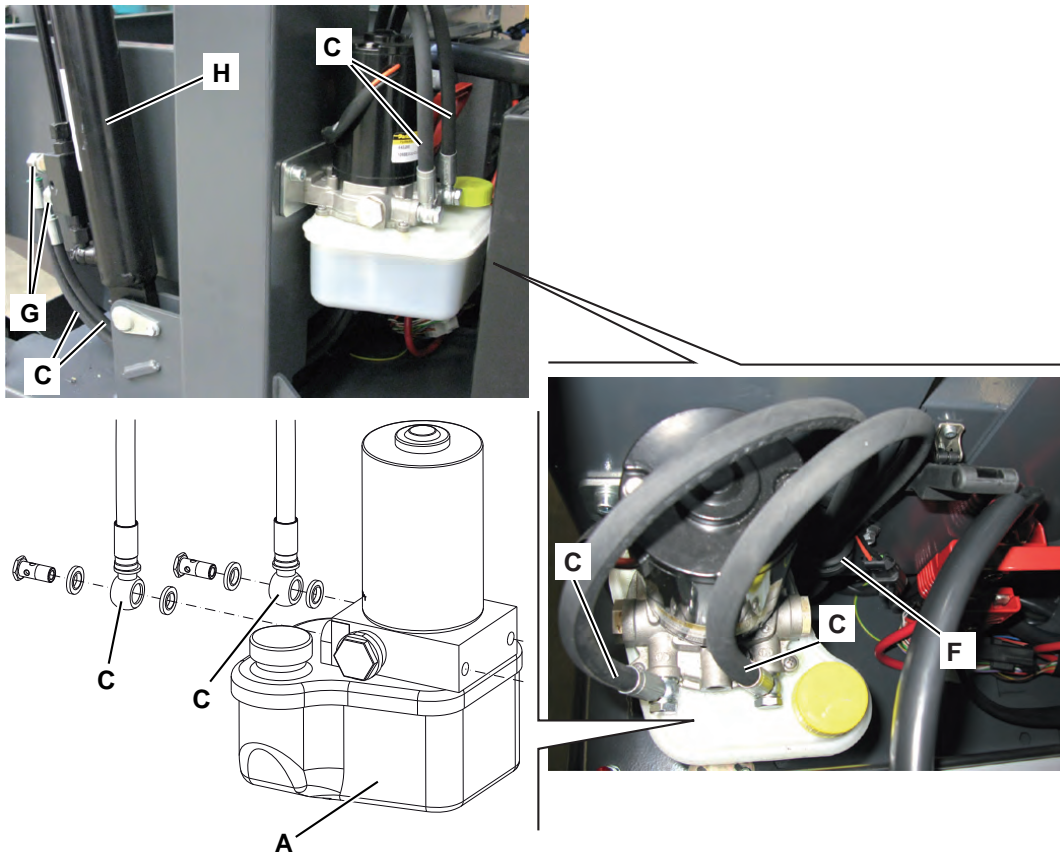

Hydraulic Cylinder Disassembly/Assembly

Disassembly

1. Drive the machine on a level floor.
2. Ensure that the hopper is closed.
3. Turn the ignition key to “0” and engage the parking brake.
4. Open the battery/engine compartment hood with the handle and fasten it with the support rod.
5. Remove the machine right side bulkhead, by lifting it to disengage it from the fasteners.
6. Unscrew the connecting fittings (B) of the hydraulic cylinder hoses (C).

Collect the hydraulic system oil in a proper container.

Plug the disconnected fittings, to prevent debris from entering into the hydraulic system.



Warning! *Hydraulic system oil is highly corrosive.*



Warning! *The hydraulic system oil should be disposed of properly according to the Law in force.*

7. Remove the screw (D) and remove the lower pin (E) of the cylinder.
8. Remove the cotter pin and the upper pin (F) of the cylinder.
9. Remove the cylinder (C).

Assembly

10. Assemble the components in the reverse order of disassembly, and note the following:
 - After the installation of the cylinder (either the same cylinder or a new one), fill the tank with hydraulic oil up to the Max level, then run some hopper handling (the hydraulic system is self-bleeding); then, check the hydraulic system oil level.

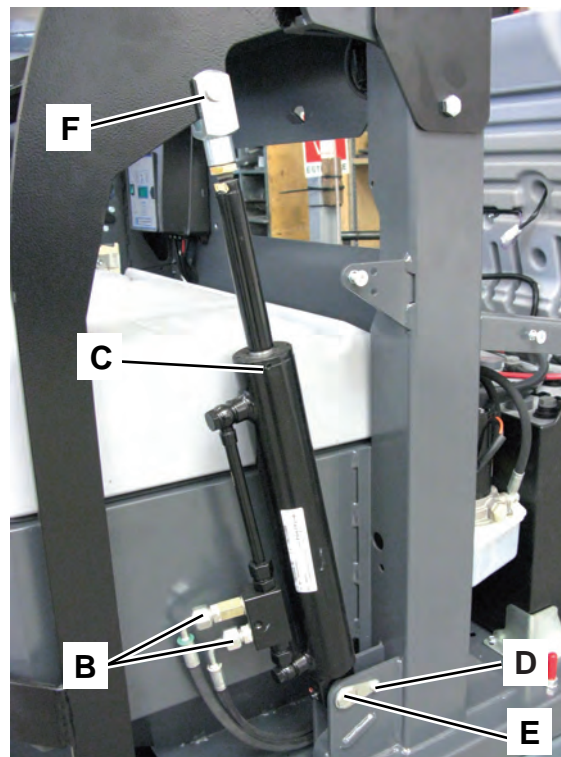

Specifications

Hopper System	Values		
	SW4000 Battery	SW4000 Petrol	SW4000 LPG
Hopper capacity	19.8 US gal (75 liters)		
Maximum weight liftable by the hopper	220 lb (100 kg)		
Hopper maximum lifting height	62.6 in (1,590 mm)		

Hopper hydraulic lifting system	Values		
	SW4000 Battery	SW4000 Petrol	SW4000 LPG
Pump	Parker 108 AE S32 - 24 V		
Maximum pressure	1,595 psi (110 Bar)		
Oil tank capacity	0.2 US gal (0.75 liters)		
Hydraulic circuit total capacity	0.4 US gal (1.4 liters)		



Caution! *If the machine is to be used at ambient temperatures below +10°C, the oil should be changed with equivalent oil having a viscosity of 32 cSt. For temperatures below 0°C, use an oil with lower viscosity.*

Hydraulic oil technical data			
AGIP ARNICA		46	32
Viscosity at 104 °F (40°C)	in ² /s (mm ² /s)	0.07 (45)	0.05 (32)
Viscosity at 212 °F (100°C)	in ² /s (mm ² /s)	0.012 (7.97)	0.009 (6.40)
Viscosity index	/	150	157
Flash point COC	°F (°C)	419 (215)	396 (202)
Pour point	°F (°C)	-32.8 (-36)	-32.8 (-36)
Density at 59°F (15°C)	lb/gal (kg/l)	1.9 (0.87)	1.9 (0.865)

Optional and Accessories

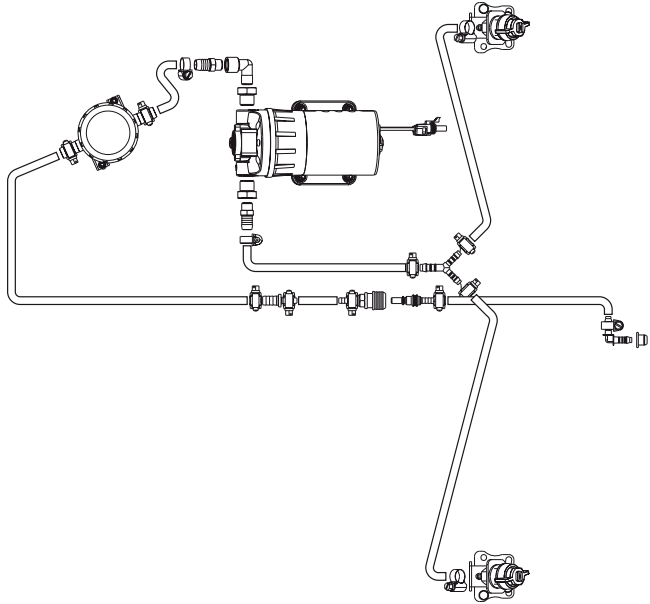
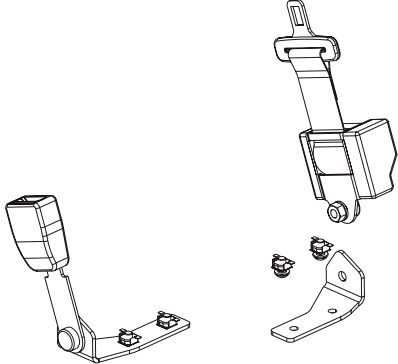
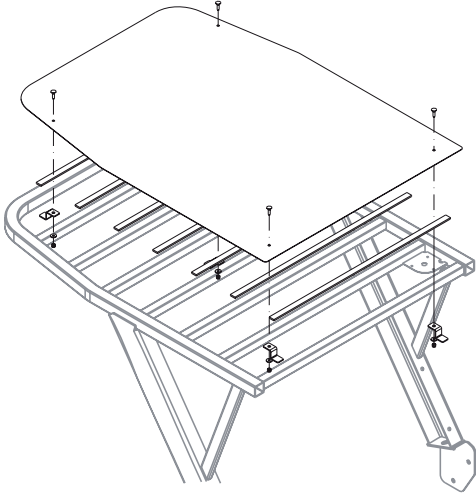
Description	Illustration
<p>DUSTGUARD™ SYSTEM KIT (See Dust Guard System chapter)</p>	
<p>SAFETY BELT KIT</p>	
<p>ROOF COVER KIT</p>	

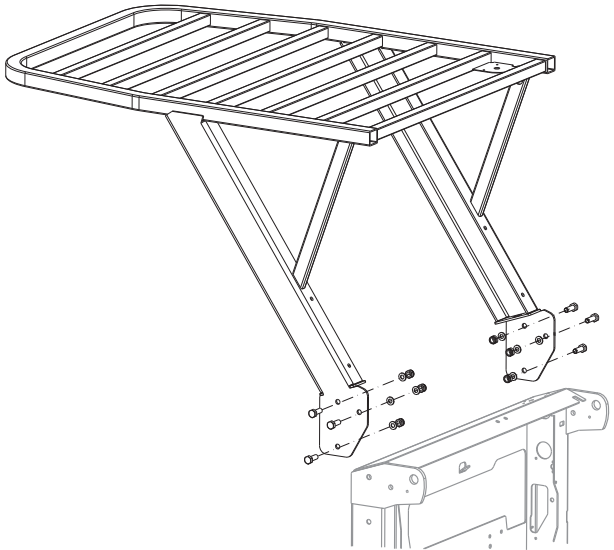
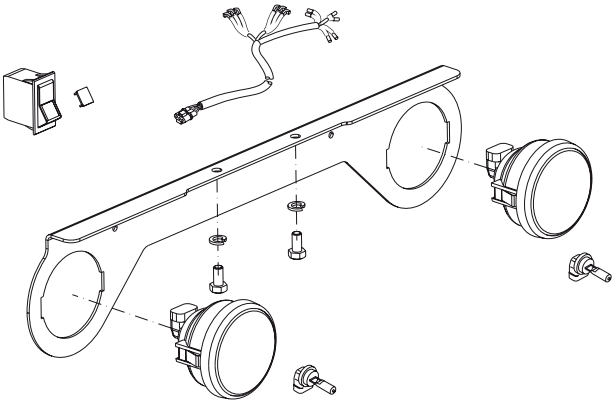
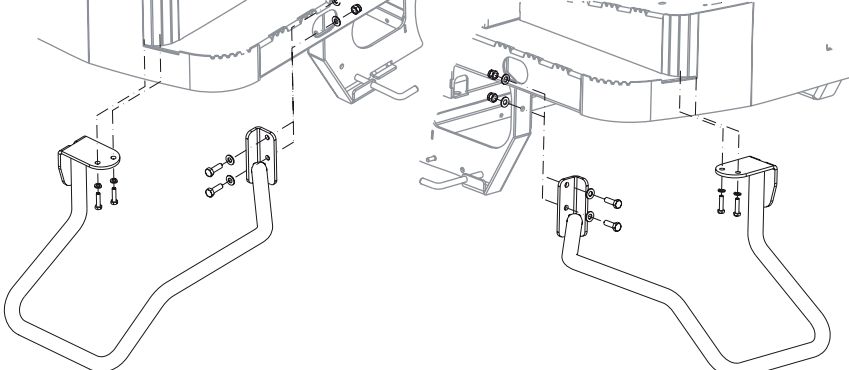
Description	Illustration
<p>PROTECTION ROOF KIT</p>	
<p>WORKING LIGHT KIT</p> <p>The working light kit improves visibility in dark environments. The headlights are installed under the chassis, in the front side of the sweeper. The kit includes one switch (SW9) to turn the lights on, one holder with two 24V 70W headlights (L1, L2) and the wiring harness.</p>	
<p>SIDE BROOM GUARD KIT</p>	

Steering System

Functional Description

The steering wheel is fastened to the steering column and connected to a shaft with a cardan joint.

The movement is transmitted with pinion and chain to the ring gear, which determines the steering. The ring gear is fastened to the driving wheel.

Component Locations

- Steering wheel
- Steering column
- Cardan joint
- Steering shaft
- Steering assembly
- Steering chain

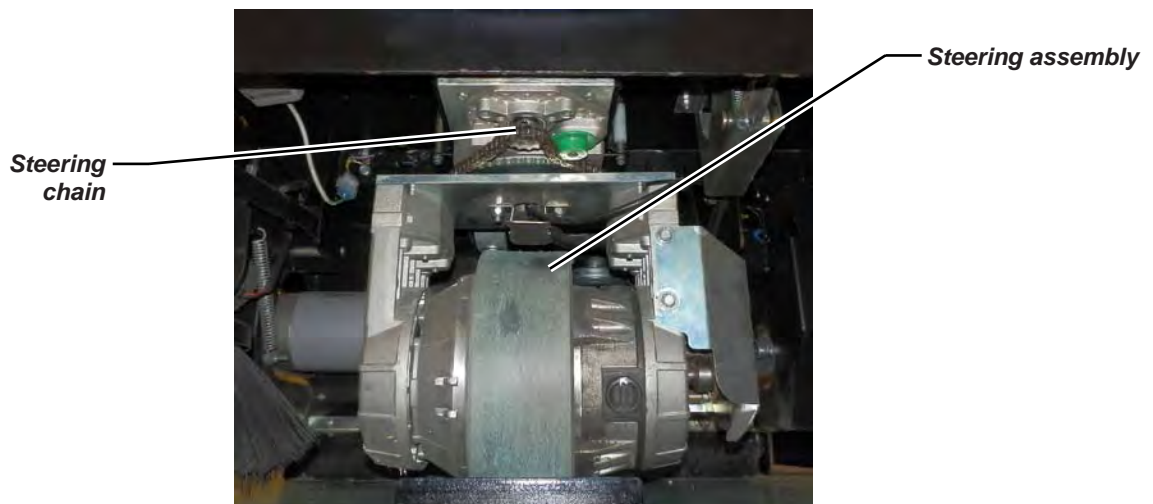
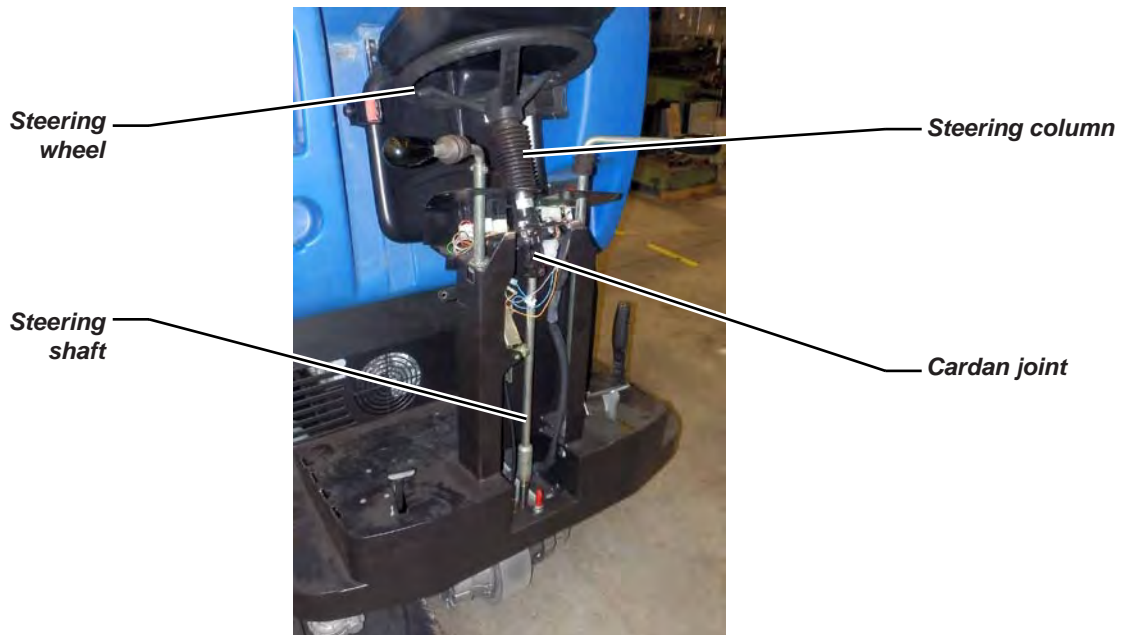

Removal and Installation

Steering Wheel Disassembly/Assembly

Disassembly

1. Drive the machine on a level floor.
2. Turn the ignition key to “0” and engage the parking brake.
3. Disengage and remove the cover (A).
4. Unscrew the nut (B) and remove the washer (C).
5. With a suitable puller, remove the steering wheel (D) using the surface (E) of the steering shaft and the threaded holes (F) of the steering wheel, or its lower edge (G); in case the lower edge (G) is used, insert metal plates between the edge and the puller, in order to distribute the load and prevent damage to the lower edge (G) itself.

Assembly

6. Assemble the components in the reverse order of disassembly.

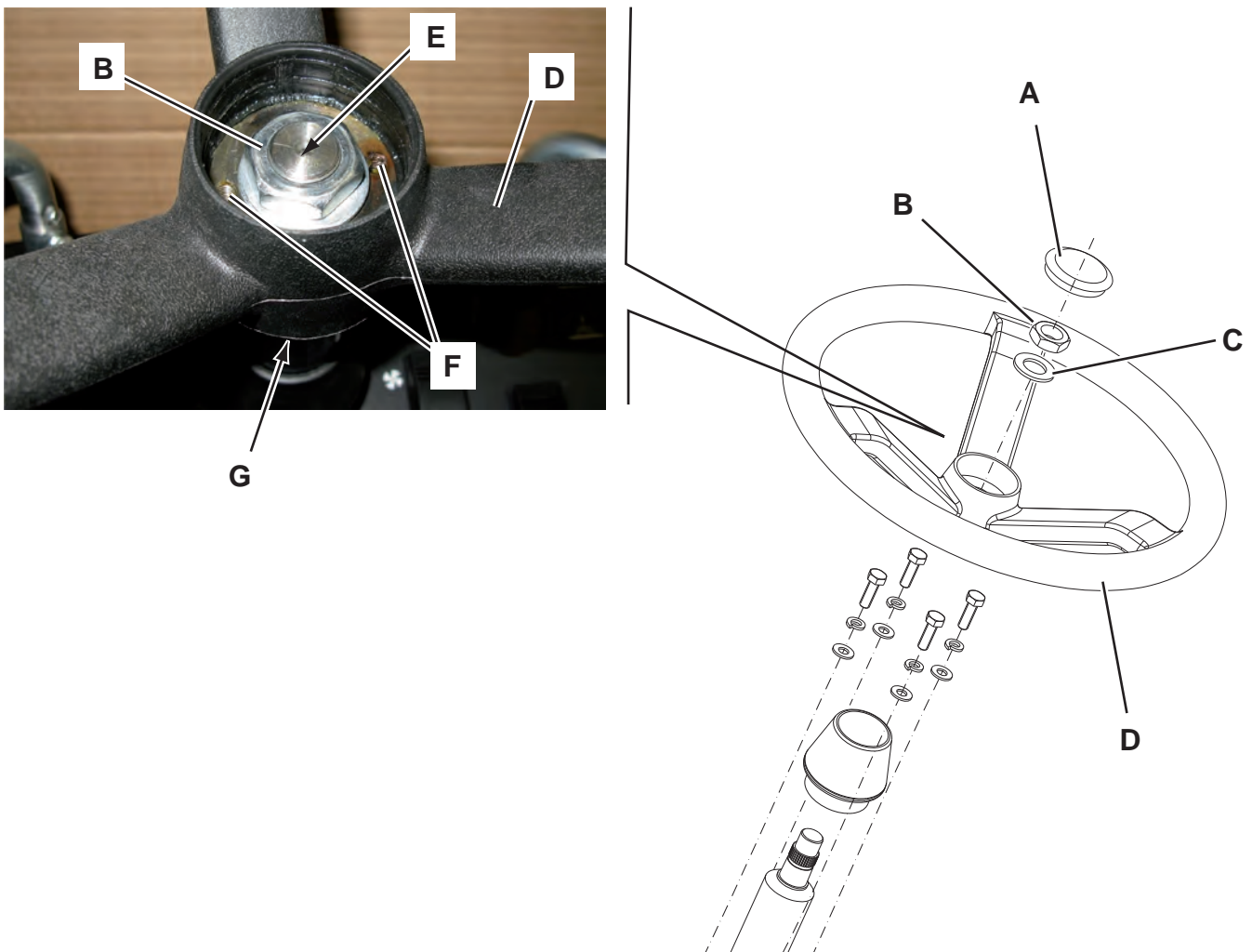

Steering Chain Disassembly/Assembly

Disassembly

1. If possible, place the machine on a hoisting system.
2. Turn the ignition key to “0” and engage the parking brake.
3. Steer the front wheel until the junction link (A) of the steering chain (B) becomes visible.
4. Disengage the link (A) and remove the chain (B).
5. Retrieve the chain tensioner pulley (C). Check the operation of the chain tensioner pulley (C).

Assembly

6. Assemble the components in the reverse order of disassembly, and note the following:
 - Do not lubricate the chain (B), otherwise dust and debris will stick to the lubricant.

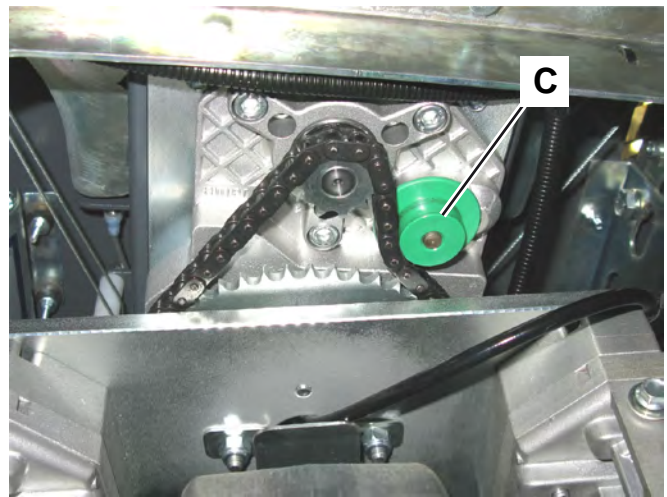
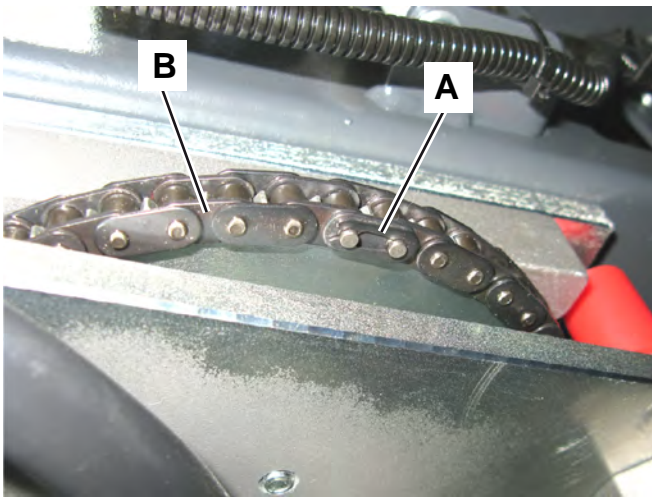

P200167

Steering Assembly Removal/Installation

1. Refer to the procedure: Driving Wheel and Steering Unit Disassembly/Assembly

Main Broom System

Functional Description

By using the left lever on the dashboard the main broom support system lowers, because it is released by a metal cable; the broom is kept pressed to the ground by two gas springs that ensure the contact with the ground at all times.

The electric motor transmits the motion to the main broom by means of a drive belt connected to an hexagonal driver that supports the broom.

The machine must be moving otherwise the main broom motor does not run.

The front skirt lifting pedal allows to collect medium size waste materials (cans, boxes, etc.). The front skirt must be lifted only when necessary, because it affects the operation of the dust control system.

The main broom motor (M4) is supplied by the electromagnetic switch (ES1) and protected by the fuse (FA). The electromagnetic switch (ES1) is activated by the dashboard electronic board (EB2) according to the information received by: sensor (S2) (main broom control lever position), machine moving signal (information that EB2 receives from EB1), lifted hopper signal, battery voltage (see Dashboard Electronic Board Specifications, step d).

The fuse (FA) activates in case of short circuit or blocked rotor, but in case of overload, the dashboard electronic board (EB2) reads the voltage drop on the fuse, thus deactivating ES1 before the fuse can activate (see Main Broom Motor Protection, in Dashboard Electronic Board Specifications). The activation of an electronic protection is indicated by the main broom overload warning light (A).

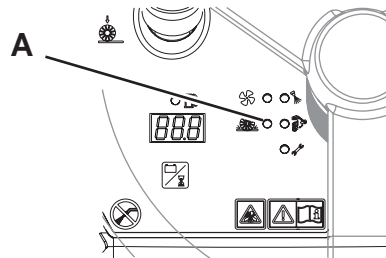

P200235

Wiring Diagram

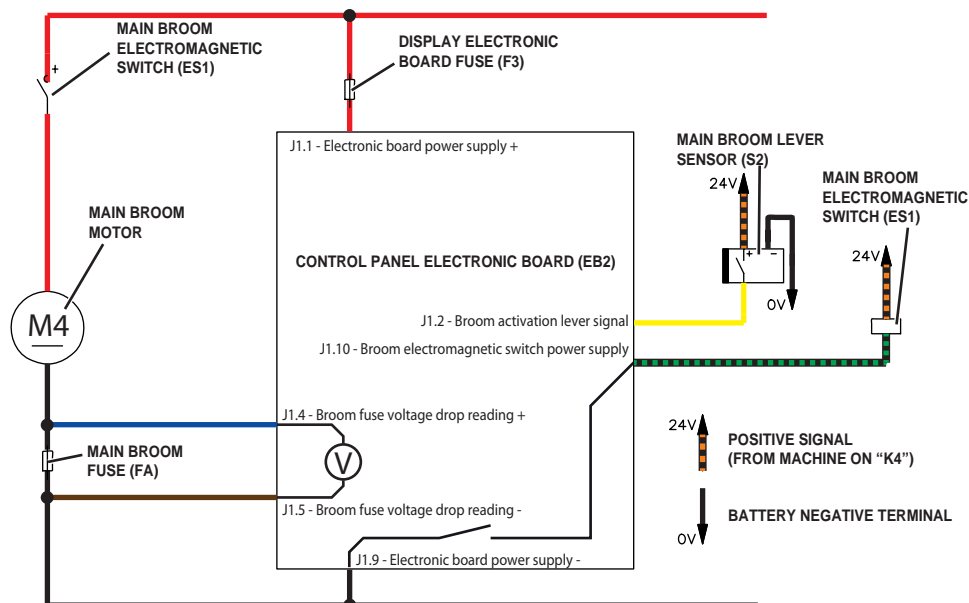

P200168

Component Locations

- Main broom lifting/lowering lever
- Main broom overload warning light
- Main broom height adjusting knob
- Main broom motor fuse (50A) (FA)
- Front skirt lifting pedal
- Main broom

Main broom lifting/lowering lever



Main broom overload warning light



Main broom height adjusting knob

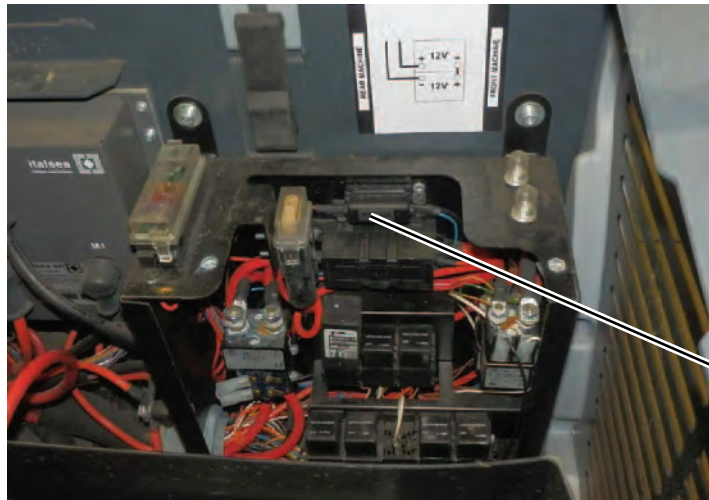

Main broom motor fuse (50A) (FA)

Front skirt lifting pedal

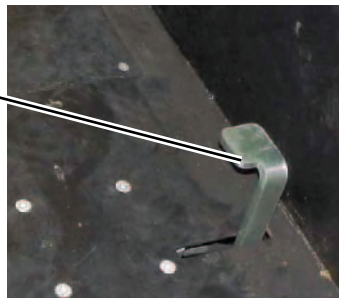

Main broom



Component Locations (Continues)

- Rear skirt
- Front skirt
- Left side skirt
- Lowered main broom enabling sensor (S2)
- Driving belt
- Main broom motor (M4)
- Motor pulley
- Right side skirt
- Broom pulley
- Device to adjust the parallelism between the main broom and the floor.

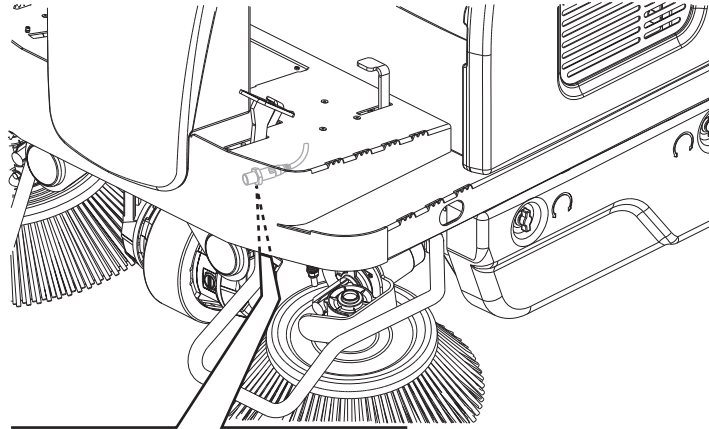

Lowered main broom enabling sensor (S2)



Device to adjust the parallelism between the main broom and the floor

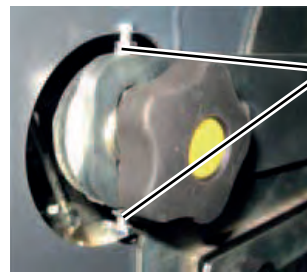

Rear skirt

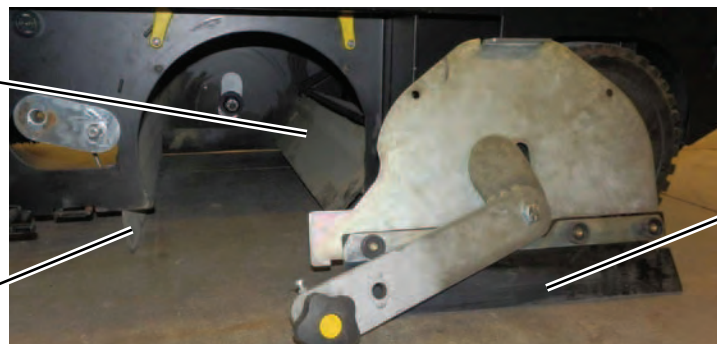

Left side skirt

Front skirt

Driving belt

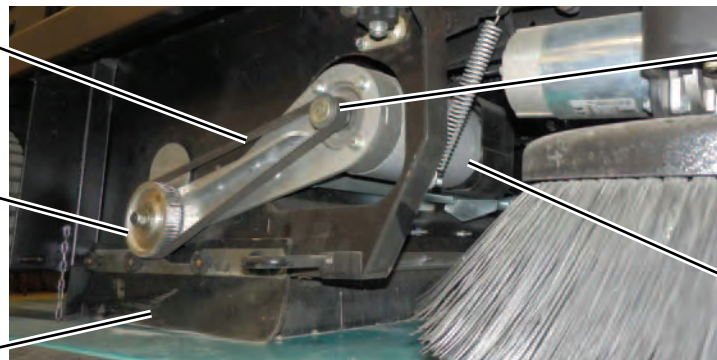

Motor pulley

Broom pulley

Main broom motor (M4)

Right side skirt

Maintenance and Adjustments

Main Broom Height Check And Adjustment



Note: Brooms with harder or softer bristles are available. This procedure is applicable to all types of brooms.



Note: The knob can be used both to adjust the print and to adjust the broom according to the bristle wear.

1. Check the main broom distance from the ground, according to the following procedure:
 - Drive the machine on a level floor.
 - Keep the machine stationary, lower the main broom and turn it on for a few seconds.
 - Stop and lift the main broom, then move the machine and switch it off.
 - Check that the main broom print (A), along its length, is 2 to 4 cm wide.
3. Perform step 1 again to check that the main broom is at the correct distance from the ground.
4. When the broom is too worn and can no longer be adjusted, replace it according to the procedure shown in the relevant paragraph.



Note: After the main broom height has been adjusted, check that the main broom overload warning light does not flash in the first minutes of operation. Otherwise the main broom pressure on the ground must be reduced by means of the relevant adjusting knob.

If the print (A) is not within specifications, adjust the main broom height according to the following procedure.

2. Turn the knob (B) and consider that:
 - to increase the print length, turn the knob counter-clockwise
 - to decrease the print length, lift the broom with the lever and then turn the knob clockwise.

5. If the print (A) cannot be properly adjusted, because the broom pressure differs from one end to another, proceed as follows.

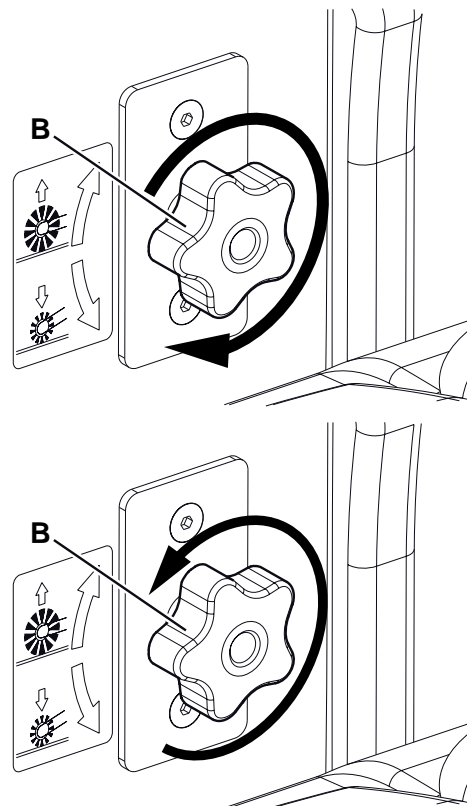
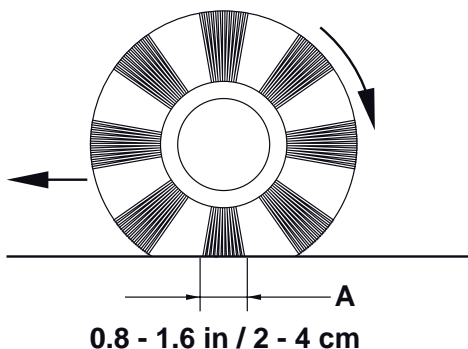
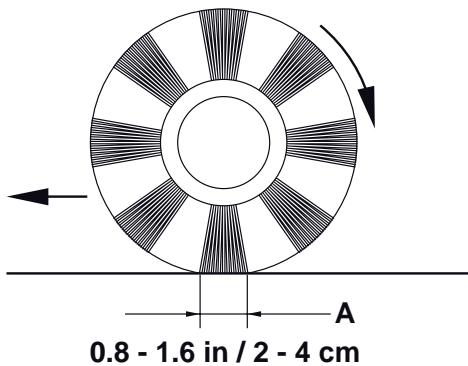

Main Broom Height Check and Adjustment (Continues)

6. Turn the fasteners and remove the left door.
7. Loosen the locknuts (C).
8. Turn the screws (D) to adjust the height of the broom left side, and adjust it to the right side, as follows:
 - Lift the lever (E) to lower the left side of the broom;
 - Lower the lever (E) to lift the left side of the broom.

When the adjustment is completed, tighten the locknuts (C).

9. Perform step 1 again to check that the main broom is at the correct distance from the ground.
10. If necessary, adjust the transmission cable adjuster.

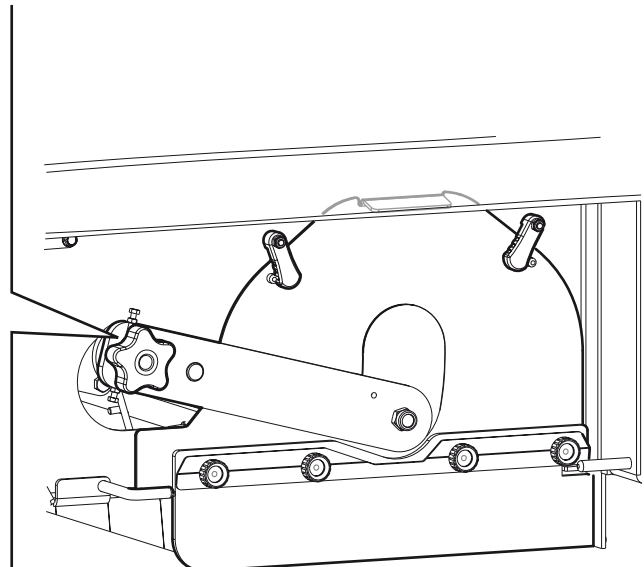
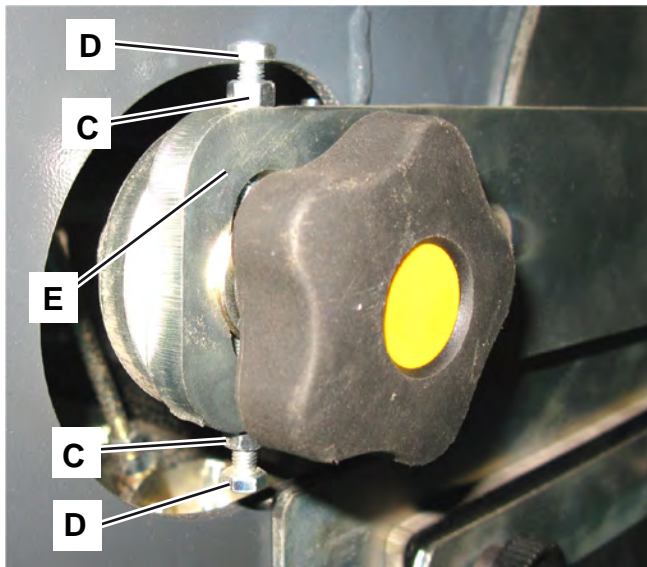

P200170

Main Broom Disassembly/Assembly



Note: Brooms with harder or softer bristles are available. This procedure is applicable to all types of brooms.



Warning! It is advisable to wear protective gloves when replacing the main broom because there can be sharp debris between the bristles.

Disassembly

1. Drive the machine on a level ground and engage the parking brake.
2. Turn the ignition key to “0” and remove it.
3. Turn the fasteners and remove the left door.
4. Unscrew and remove the knob (A).
5. Turn the levers (B) upwards.
6. Remove the broom compartment latch (C) by grabbing it from its fold (D).
7. Remove the main broom (E).

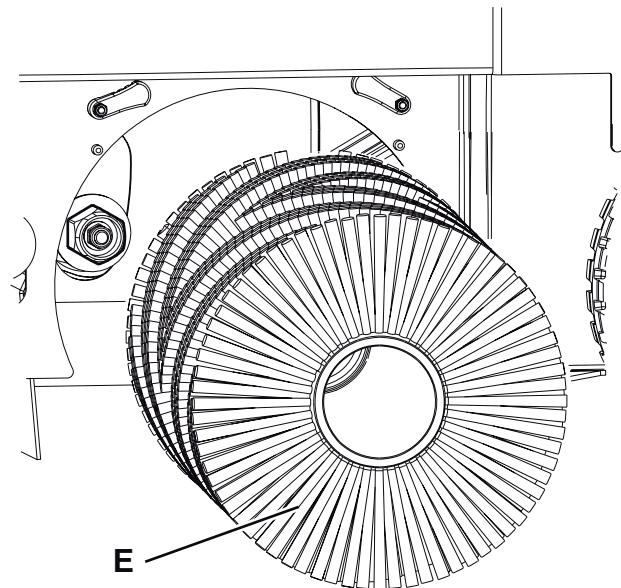
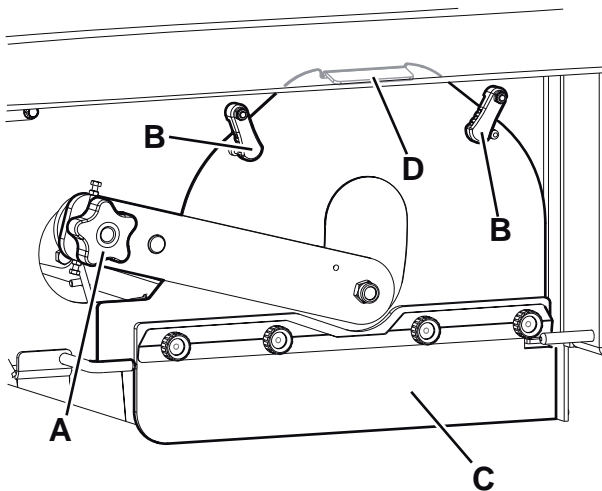

Main Broom Disassembly/Assembly (Continues)

Assembly

8. Check that the drive hub (F) is free from dirt or foreign materials (cords, rags, etc.) accidentally rolled up.
9. The main broom (E) must be installed with the bristles rows (G) bent as shown in the figure.
During assembly, ensure that the broom hexagonal mesh (H) fits into the relevant drive hub (F).
10. Install the broom compartment latch (C). Ensure that its fasteners (I) are properly fitted in the housings (J) of the machine chassis.
11. Turn the levers (B) to lock the latch (C) in its housing.
12. Screw down the knob (A).
13. Install the left door and secure it with the relevant fasteners.
14. Check and, if necessary, adjust the main broom height.

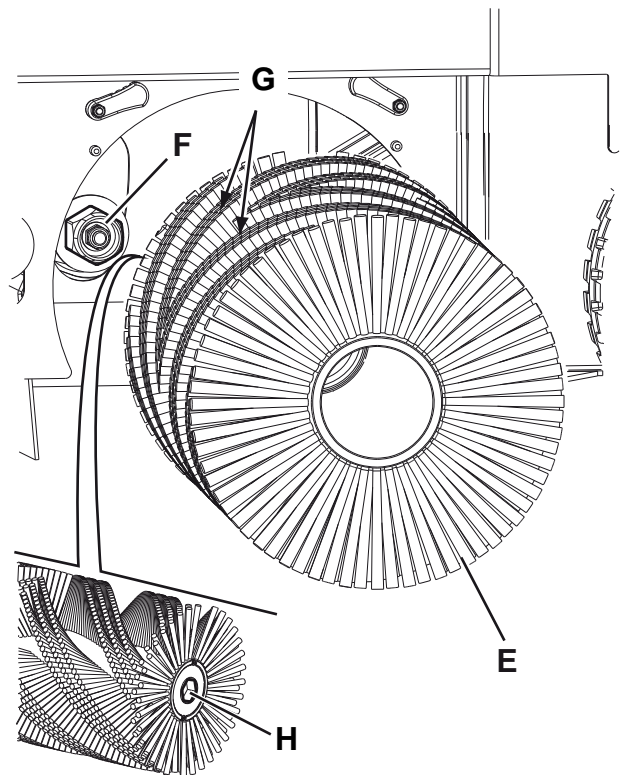
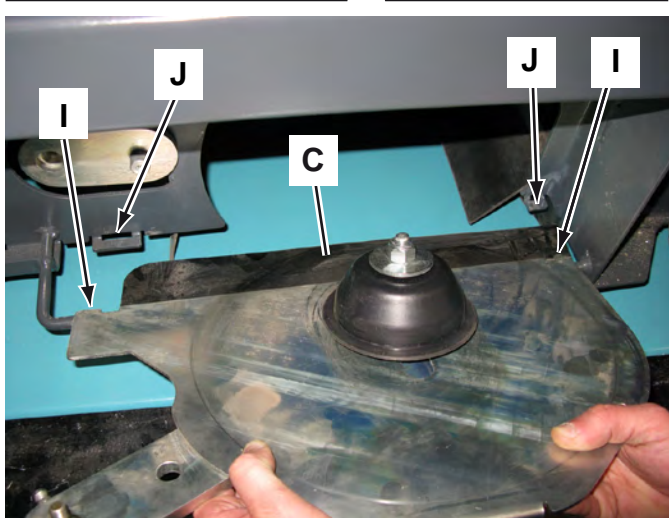
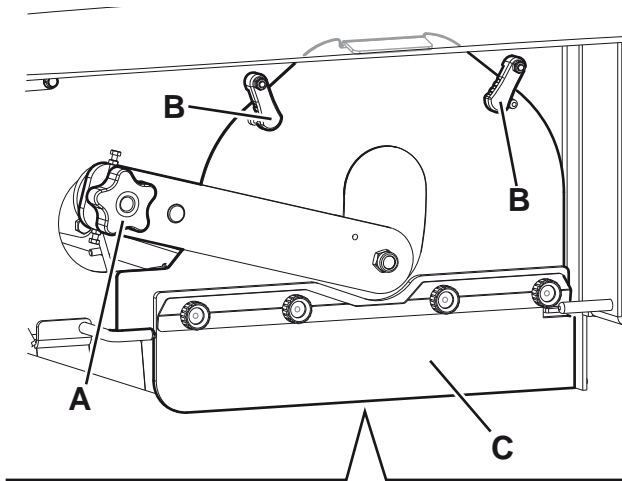

Skirt Height Check and Adjustment

Preliminary Operations

1. Empty the hopper (as shown in the User Manual), because the weight of the waste inside the hopper can affect the skirt height check.
2. Drive the machine on a level ground that is suitable for checking the skirt height.
3. Turn the ignition key to “0” and engage the parking brake.

Side Skirt Check

4. Remove the machine left and right doors by turning the relevant fasteners.
5. Check the side skirts (A) for integrity.

Replace the skirts when they have cuts (C) larger than 20 mm or cracks/tears (D) larger than 10 mm (see the procedure in “Skirt Disassembly/Assembly”).

6. Check that the distance from the ground (E) of the side skirts (A) is 0 - 3 mm. If necessary, loosen the knobs (B) and adjust the skirt position. Then tighten the knobs (B).

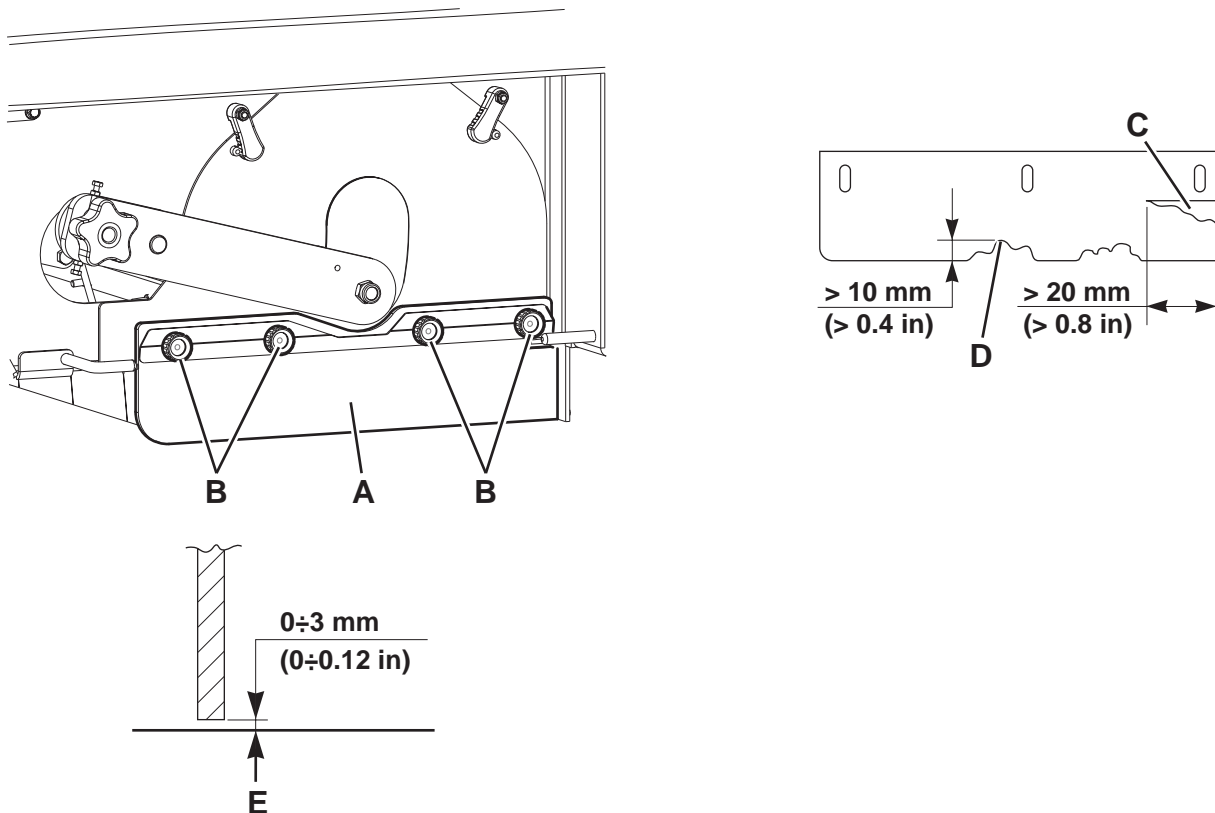

Skirt Height Check and Adjustment (Continues)

Front and Rear Skirt Check

- Remove the main broom.
- Check the front skirt (F) and rear skirts (G) and (H) for integrity.

Replace the skirts when they have cuts (C) larger than 20 mm or cracks/tears (D) larger than 10 mm (see the procedure in “Skirt Disassembly/Assembly”).

- Check that the front skirt (F) and rear skirt (H) slightly rub the floor without being detached from it (see the diagram (I)).

Reassembly

- Assemble the components in the reverse order of disassembly.

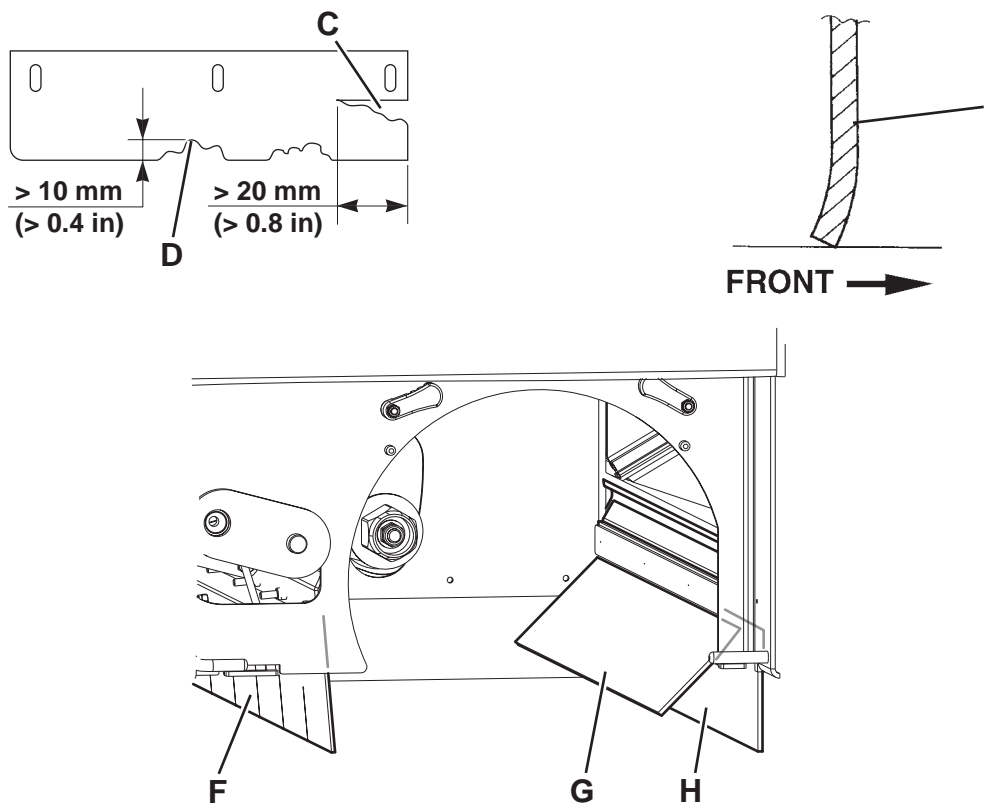

Troubleshooting

Trouble	Possible causes	Remedy
The main broom does not work and the warning light (76) flashes.	The safety system has activated.	Turn off the machine and then turn it on again. Check the condition of the main broom (debris that slows down the broom or excessive pressure on the ground).
	The fuse (FA) is open.	Wait for the main broom motor to cool down, then replace the fuse.
	The electromagnetic switch (ES1) is not efficient	Replace
	The driving belt is misadjusted/damaged/broken	Tighten/replace
	The motor (M4) is faulty	Check the motor amperage/replace
	The sensor is misadjusted or broken	Adjust/replace
	The main broom has not been properly adjusted in height/parallelism	Adjust
The main broom does not clean properly	The main broom is too worn out	Replace
	The skirts are misadjusted or damaged	Adjust/replace
	The gas springs are damaged or without pressure	Replace
The main broom jumps or vibrates	The gas springs are damaged	Replace

Removal and Installation

Driving Belt Visual Inspection and Replacement

Check

1. Drive the machine on a level floor.
2. Turn the ignition key to “0” and engage the parking brake.
3. Remove the machine right door by turning the relevant fasteners.
4. Visually inspect the entire length of the belt (A) to make sure it is intact and shows no signs of cuts, tears or cracks, if necessary replace it.

Replacement

5. Loosen the screws (C) and (D), then loosen the belt by turning the motor assembly (B).
6. Remove the belt (A).
7. Install the new belt (A).
8. Tighten the belt (A) as necessary by turning the motor assembly (B), then tighten the screws (C) and (D).

Reassembly

9. Install the machine right door by turning the relevant fasteners.

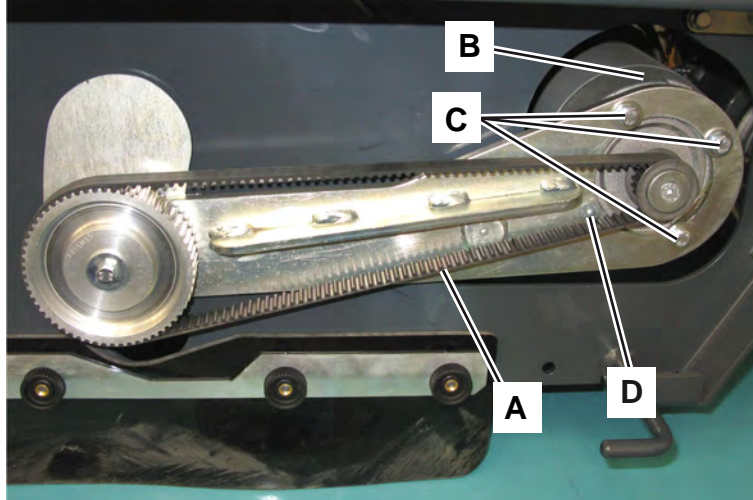

Skirt Disassembly/Assembly

Preliminary Operations

1. Empty the hopper (as shown in the User Manual), because the weight of the waste inside the hopper can affect the skirt height check.
2. Drive the machine on a level ground that is suitable for checking the skirt height.
3. Turn the ignition key to “0” and engage the parking brake.

Side Skirt Removal and Installation

4. Remove the machine left and right doors by turning the relevant fasteners.
5. Unscrew the knobs (A).
6. Remove the plate (B) and the right/left skirt (C).
7. Assemble the right/left skirt (C) and the plate (B).
8. Screw down the knobs (A), without tightening them.
9. Check the skirt height.

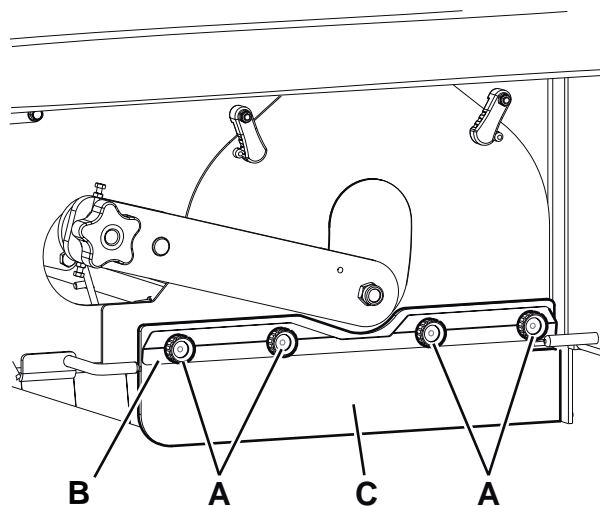

Skirt Disassembly/Assembly (Continues)

Front Skirt Removal and Installation



Note: It is advisable to place the machine on a hoisting system.

10. Remove the main broom.
11. Remove the side brooms.
12. On the left front side of the front skirt (D), disengage the clip (E) then disconnect the terminal (F) of the skirt lifting tie rod from the bracket (G).
13. Remove the six nuts (H) then remove the strap (I) from the main broom compartment.
14. Remove the front skirt assembly (J) from the front.
15. At the workbench, unscrew the six nuts (K) and remove the section bar (L) and the strap (M).
16. Retrieve the front skirt (N).
17. Install the front skirt (N) in the reverse order of disassembly.
18. Check the front skirt height.

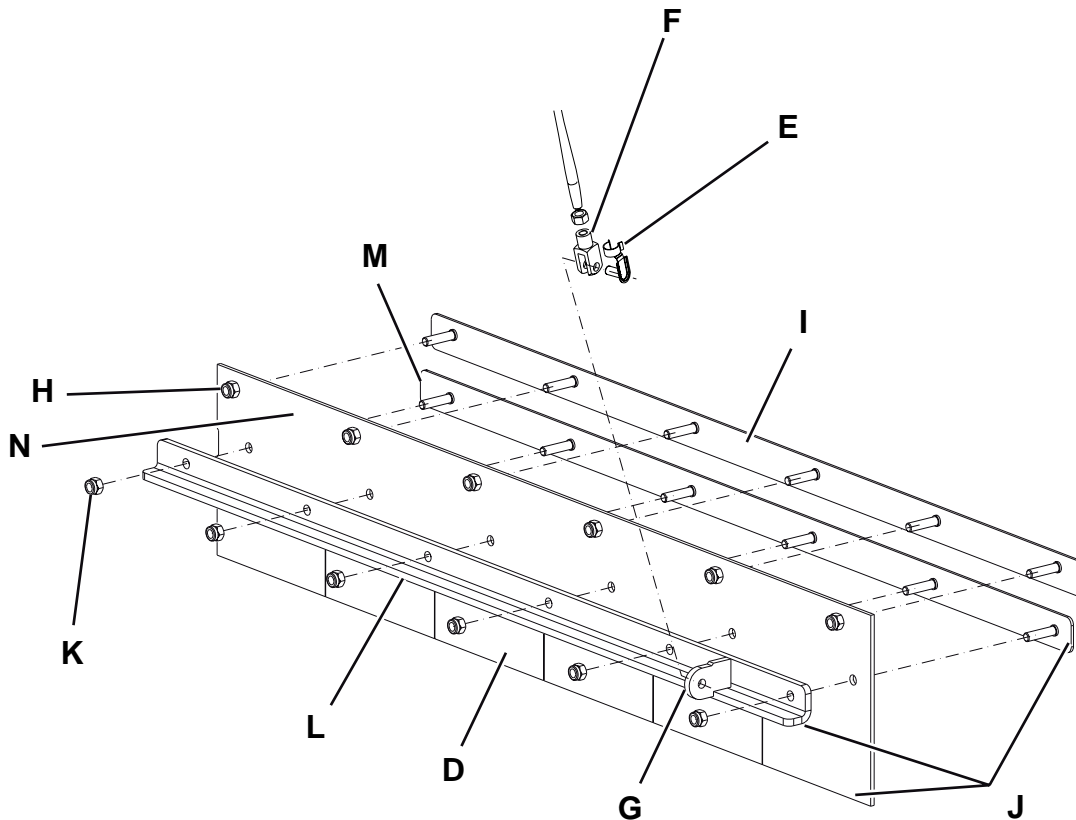

Skirt Disassembly/Assembly (Continues)

Rear Skirt Removal and Installation

19. Remove the main broom.
20. Lift the hopper to the end-of-stroke.



Warning! Place a safety rod under the lifted hopper.

21. In the hopper compartment, remove the nuts (P) and then remove the strap (Q) and the skirt (R).
22. In the main broom compartment, remove the strap (S) and remove the skirt (T).
23. Install the rear skirts (T) and (R) in the reverse order of disassembly.
24. Check the rear skirt height.

Reassembly

25. Assemble the components in the reverse order of disassembly.

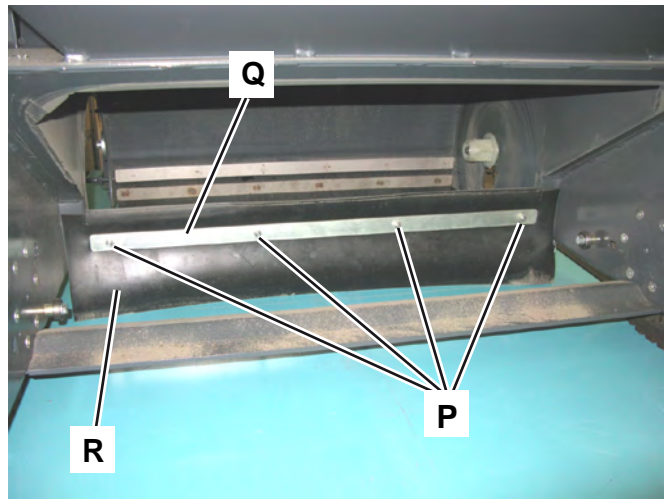
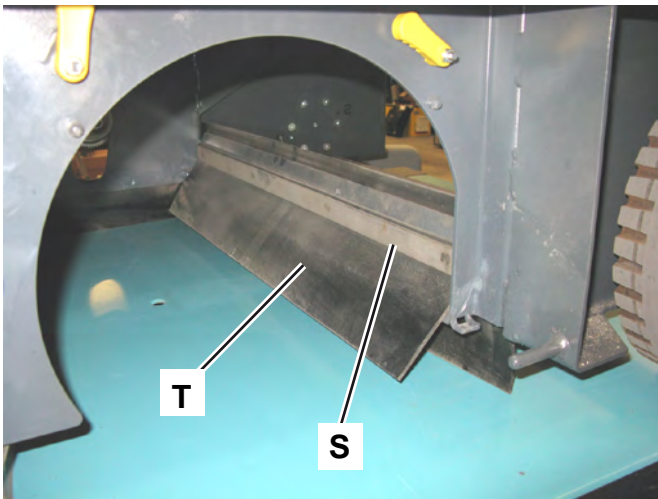

Main Broom Motor Amperage Check



Warning! This procedure must be performed by qualified personnel only.

1. Remove the main broom.
2. Check that the main broom drive hub is free from dirt or foreign materials (ropes, rags, etc.) accidentally rolled up, which can prevent it from rotating.
3. Remove the right side broom.
4. Place wedges (A) on the rear wheels of the machine.
5. With a proper hoisting system applied to the machine chassis, to the front wheel area (B), lift the machine a few centimetres, in order to let the front wheel turn freely without touching the floor.
6. Apply amp clamps (C) on a cable (D) of the main broom motor (E).
7. Turn the ignition key to “I”.
8. Turn on the main broom and check that the amperage of the motor (E) is 5 - 7 A at 24 V.

Stop the main broom rotation.

Turn the ignition key to “0”.

Remove the amp clamps (C).

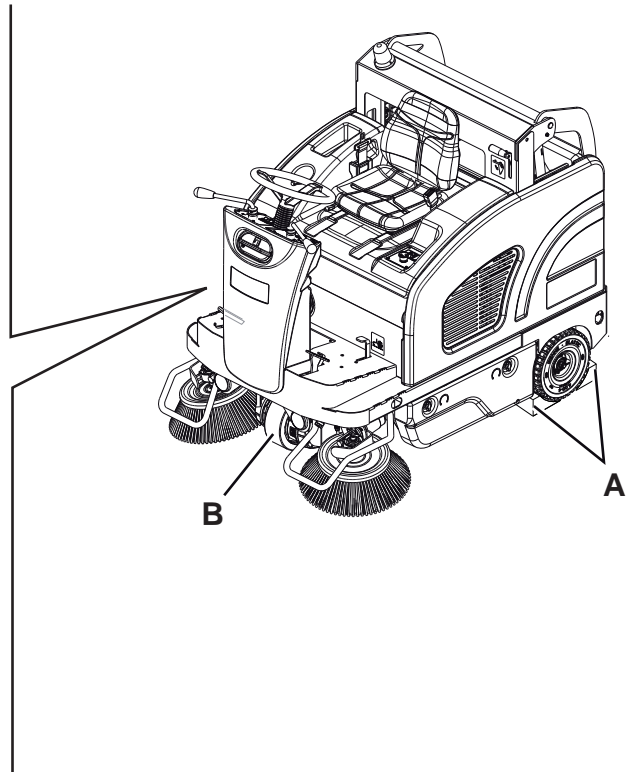
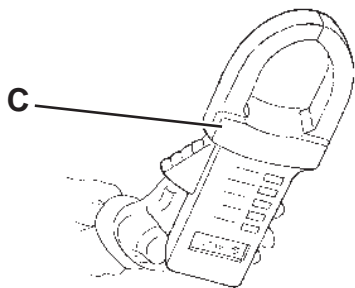
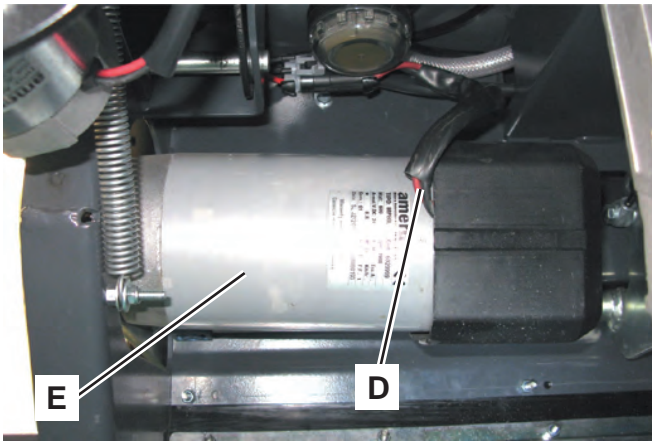

Main Broom Motor Amperage Check (Continues)

If the amperage is higher, perform the following procedures to detect and correct it:

- Check the relevant fuse (FA) for proper tightening.
- Check if there is dust or dirt (cords, cables, etc.) on the broom drive hub.
- Check that the driving belt is efficient and properly tightened.
- Check the motor carbon brushes (see the procedure in “Main Broom Motor Carbon Brush Check/Replacement”).
- If necessary, disassemble the motor (see procedure in the next paragraph), and check the condition of all its components.

If the above-mentioned procedures do not lead to a correct amperage, the motor must be replaced (see the procedure in the next paragraph).

Reassembly

9. Install the right side broom.
10. Install the main broom.
11. Remove the front hoisting system of the machine.
12. Remove the wedges from the rear wheels.

Main Broom Motor Disassembly/Assembly

Disassembly

1. Remove the main broom driving belt (see the procedure in “Driving Belt Visual Inspection and Replacement”).
2. Disconnect the connector (A) of the main broom motor (B).
3. Loosen the screws (C).
4. Remove the main broom motor (B).

Assembly

5. Assemble the components in the reverse order of disassembly.

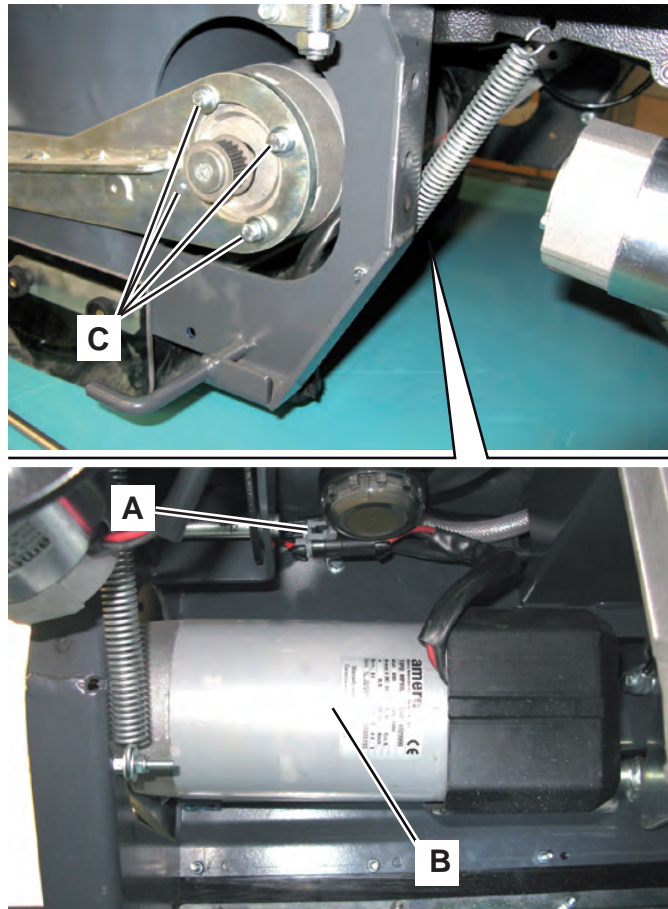

Main Broom Motor Carbon Brush Check/Replacement

Disassembly

1. Remove the main broom motor (see the procedure in the previous paragraph).
2. At the workbench, remove the nuts (A) and the guard (B) of the main broom motor (C).
3. If necessary, clean the external side of the motor (C) in the area of the protection band (D).
4. Disengage the cam lever (E) and remove the protection band (D).
5. Remove the fastening screws (F) of the electrical connections of the four carbon brushes (G).
6. Remove the four carbon brushes (G) from their housings, by disengaging them from the retaining springs (H).
7. Check the carbon brushes (G) for wear. The carbon brushes are worn when:
 - The contact with the motor armature is insufficient
 - The contact surface is not integral
 - The stroke is less than 0.12 in (3 mm)
 - The spring is broken

In this cases, replace all motor carbon brushes.

Assembly

8. Assemble the components in the reverse order of disassembly.

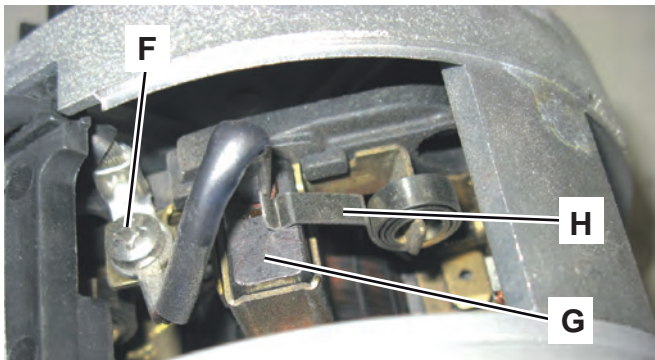
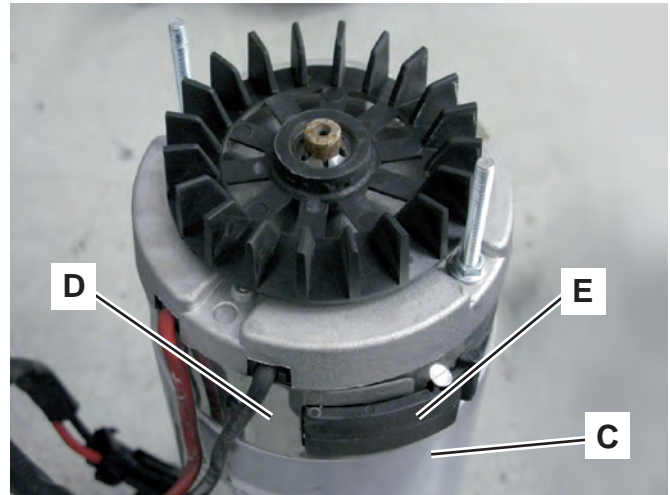
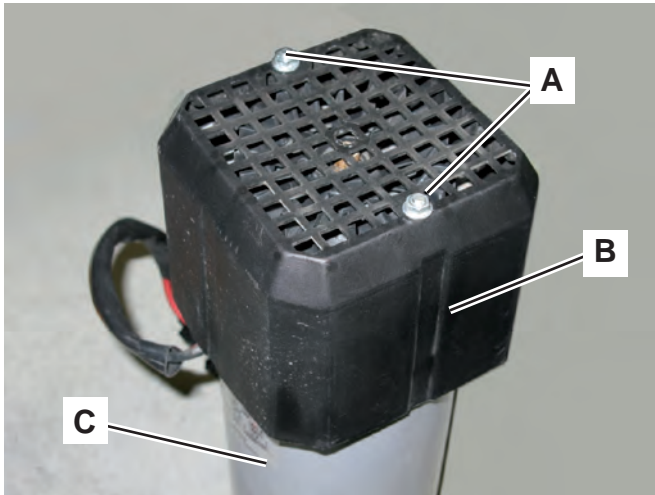

Main Broom Motor Pulley Disassembly/Assembly

Disassembly

1. Remove the main broom motor belt (see the procedure in “Driving Belt Visual Inspection and Replacement”).
2. While keeping the pulley (C) locked, remove the screw (A) and retrieve the washer (B).
3. Remove the pulley (C) and retrieve the spacer (D) and the key (E).

Assembly

4. Assemble the components in the reverse order of disassembly.

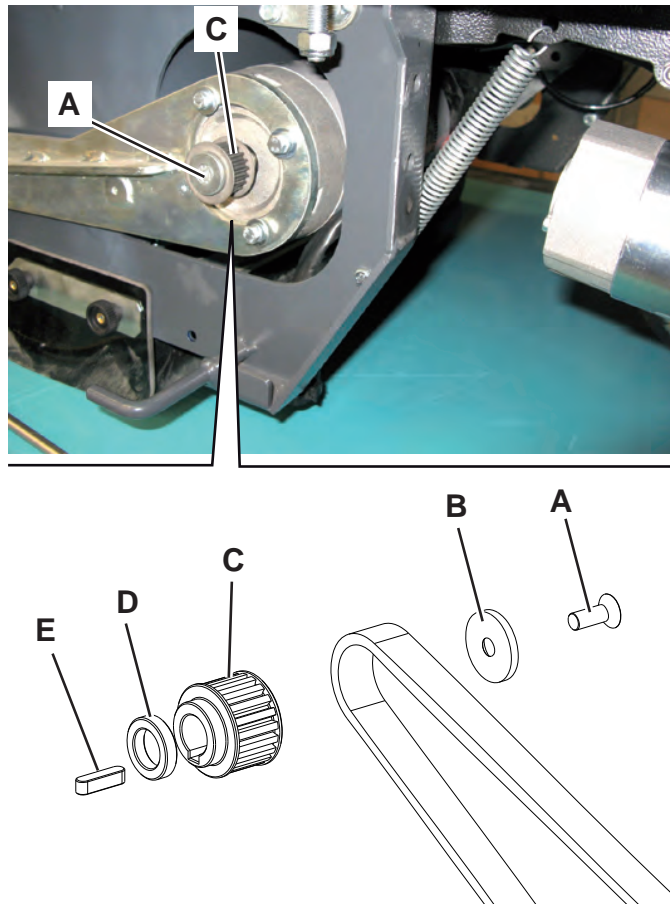

Main Broom Drive Hub and Bearing Disassembly/Assembly

BEARINGS

Disassembly

1. Remove the main broom.
2. Lift the hopper to the end-of-stroke.



Warning! Place a safety rod under the lifted hopper.

3. Remove the main broom driving belt (see the procedure in “Driving Belt Visual Inspection and Replacement”).
4. While keeping the pulley (A) locked, remove the screw (B) and retrieve the washers (C) and (D).
5. Remove the pulley (A) and retrieve the spacer (E) and the key (F).
6. Push the assembly (G) inside the machine, and then retrieve it.
7. In the hopper compartment, remove the snap ring (H).
8. On the machine outer side, with a proper pad and a mallet, push the bearings (I) outside their housings.

Assembly

9. Assemble the components in the reverse order of disassembly.

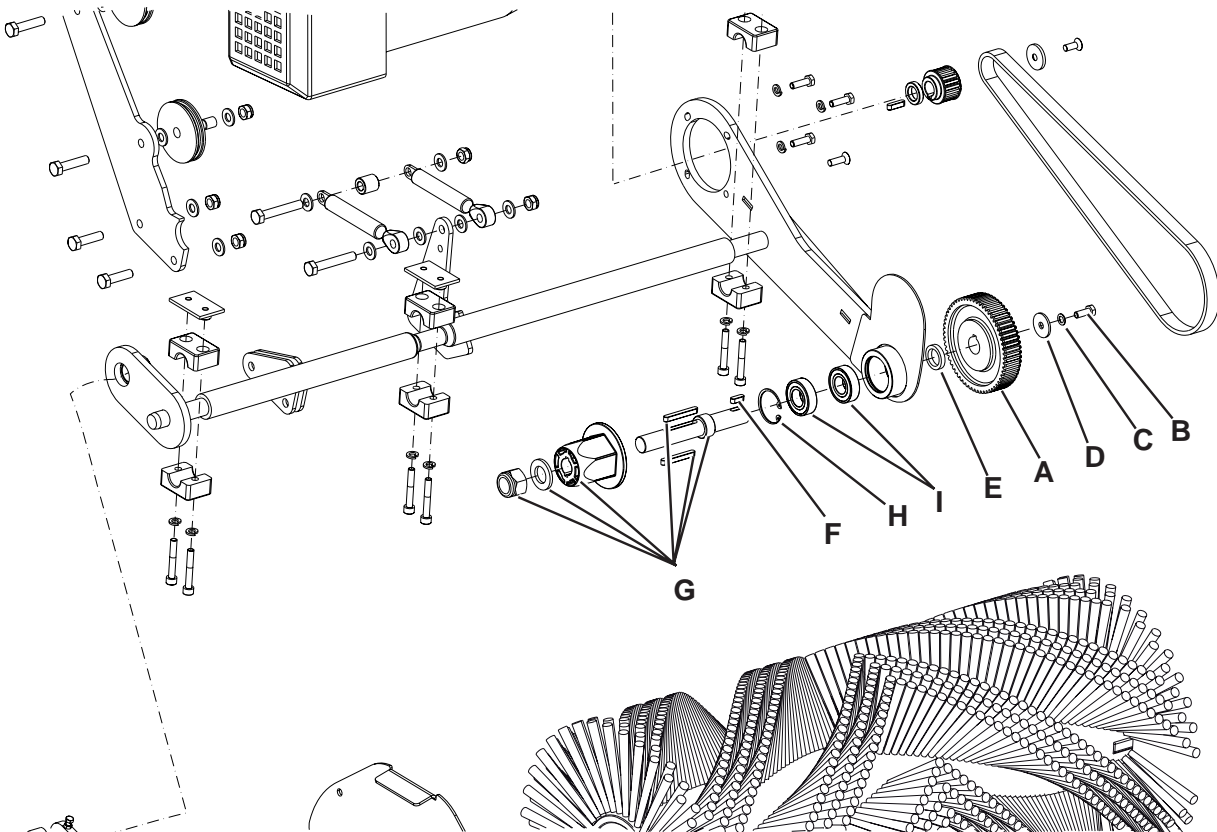

Main Broom Drive Hub and Bearing Disassembly/Assembly (Continues)

DRIVE HUB

Disassembly

1. Remove the main broom.
2. Lift the hopper to the end-of-stroke.



Warning! Place a safety rod under the lifted hopper.

3. In the hopper compartment, remove the nut (L) while keeping the drive hub locked (M).
4. Retrieve the washer (N).
5. Remove the drive hub (M) and retrieve the keys (P).

Assembly

6. Assemble the components in the reverse order of disassembly.

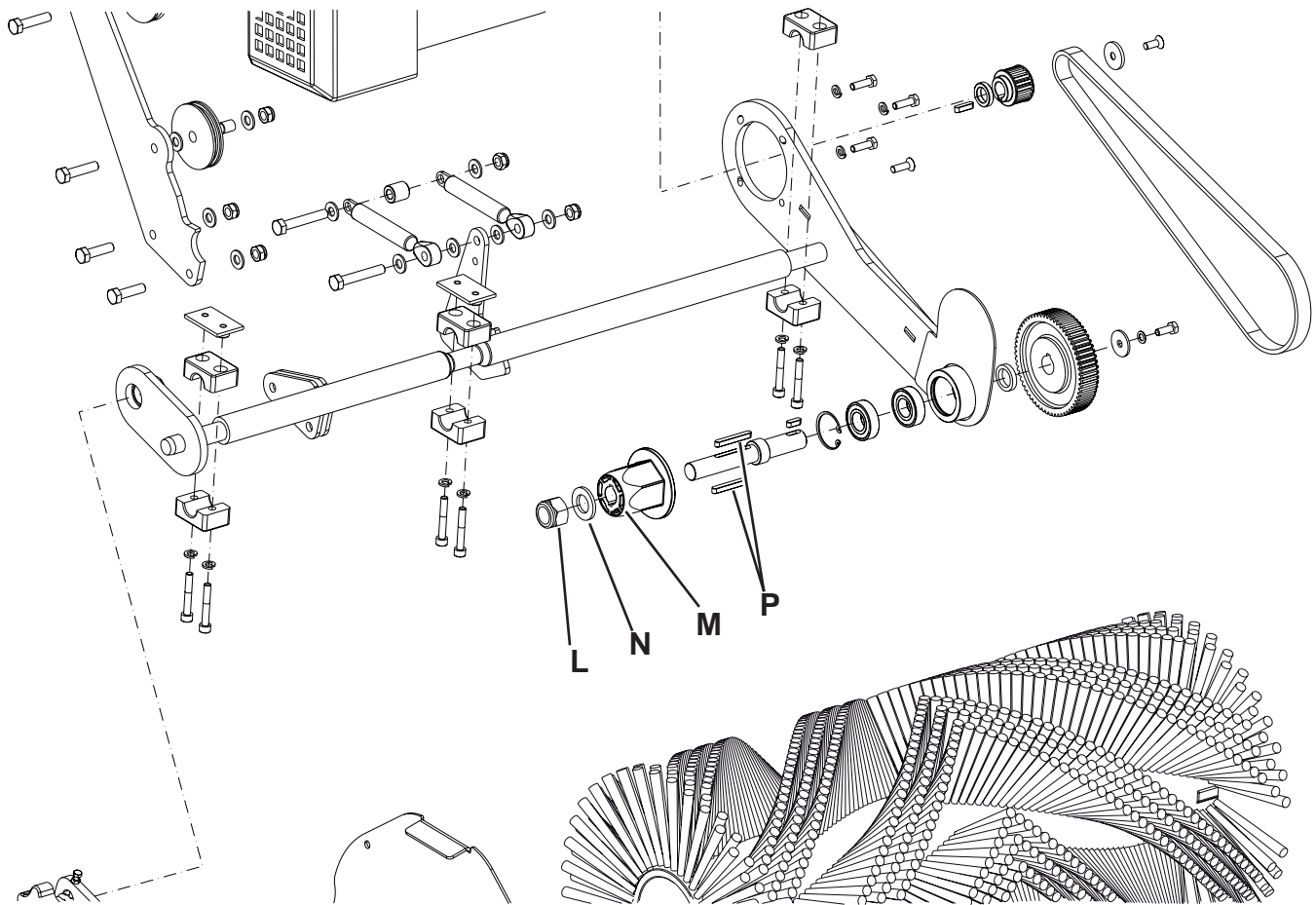

Main Broom Gas Spring Disassembly/Assembly

Disassembly

1. Place the machine on a hoisting system.
2. Remove the main broom.
3. With the knob (A), lower the main broom until the end of stroke.
4. Use the lever (B) to lower the main broom.
5. In the left front lower side of the machine, unscrew the nut (C) and disconnect the grommet (D) of the main broom lifting control cable (E) from the pin.

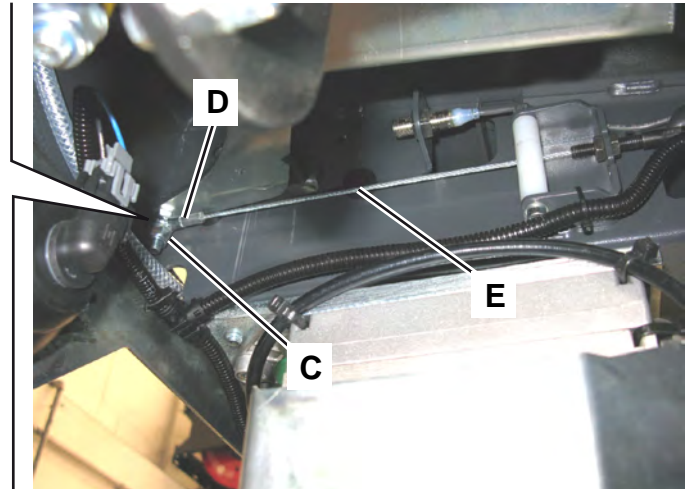
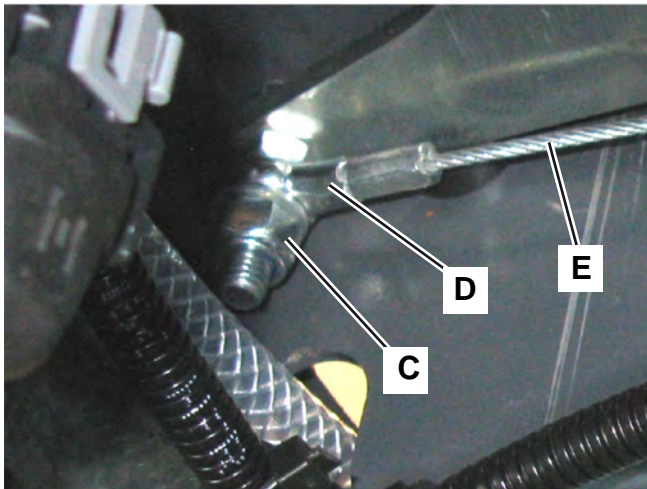
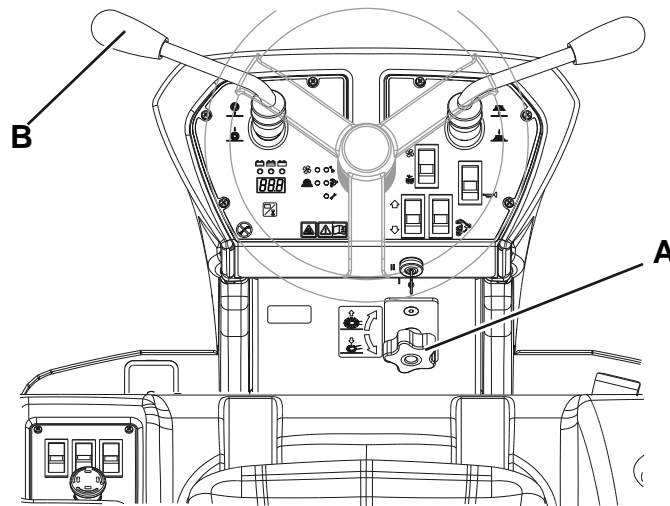

Main Broom Gas Spring Disassembly/Assembly (Continues)

6. In front of the main broom, loosen the nut (F) of the gas springs (G).
7. Insert and tighten the screw with a 8 mm nut (H) in the hole (I).
8. Insert a lever (J) between the screw (K) and the screw (H), as shown in the figure, then push it in the direction shown by the arrow until the screw (K) is disengaged by its housing and moved to the position (L) (thus the gas spring (G) will be extended).
9. Unscrew the nut (M) and remove the screw (N).



Caution! Pay attention to the release of the gas springs (G) due to any residual tension.

10. Remove the gas springs (G).

Assembly

11. Assemble the components in the reverse order of disassembly, and note the following:
 - To place the screws (L) back in the housing (O), the screw with nut (H) must be turned to position (P), then place the lever (J) in the position (Q) and push it in the direction shown by the arrow, as shown in the figure.
12. Adjust the main broom height.

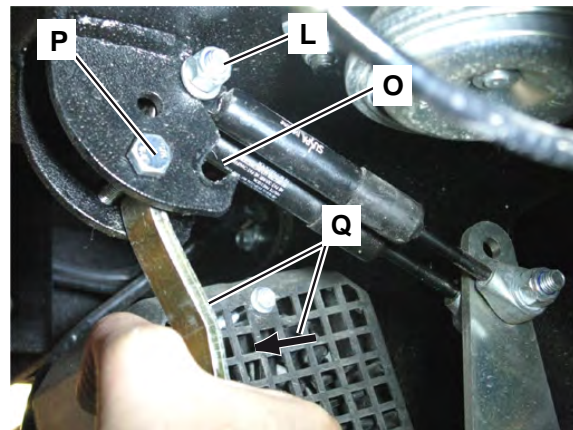
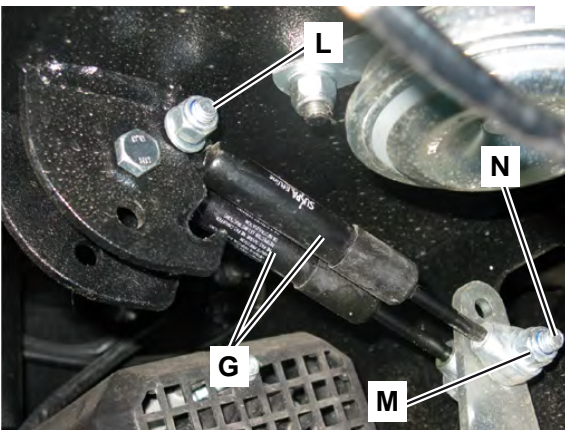
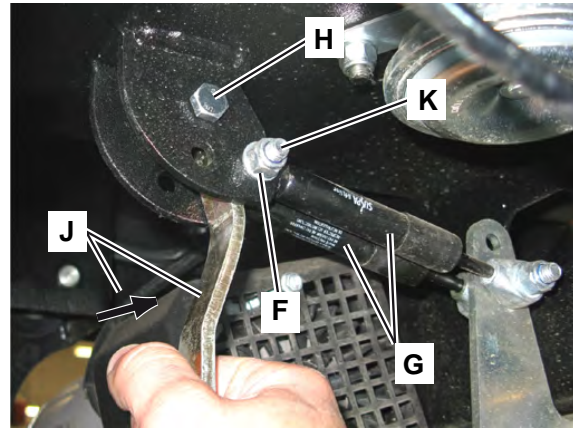
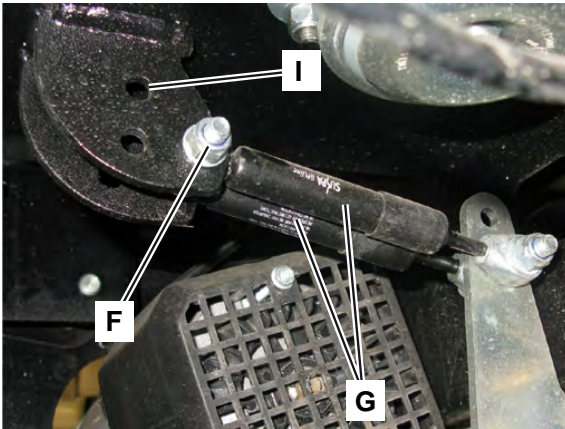

Main Broom Lifting Cable Disassembly/Assembly

Disassembly

1. If possible, place the machine on a hoisting system.
2. Remove the main broom.
3. Remove the left side broom, if equipped.
4. Remove the fastening screws (A) of the fairing (B) from the steering column.
5. Slightly lift the steering column (B) by disengaging it from the lower fastener (C).
6. Disconnect the dust guard system quick coupling (D).
7. Remove the fairing (B).
8. If necessary, drain the water from the tank in the steering column (B), through the filler neck.
9. On the rear side of the steering column, remove the screws (E).
10. Turn the knob (F) counter-clockwise until its screw (G) is removed from the arms (H).

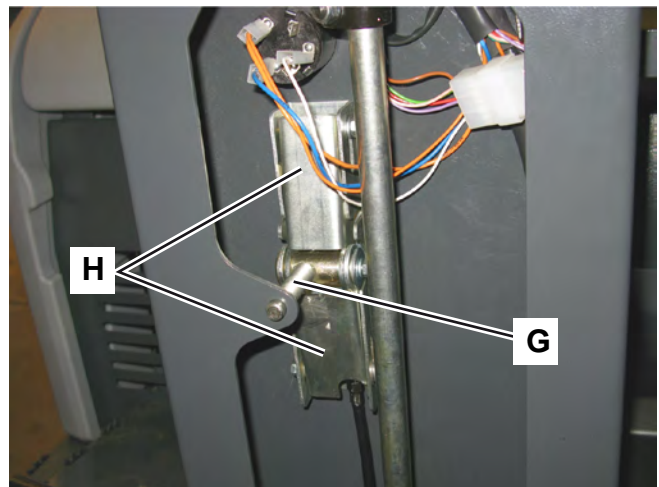
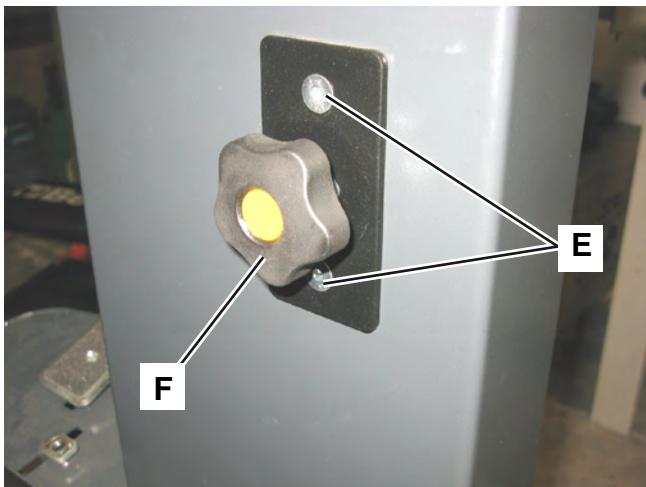
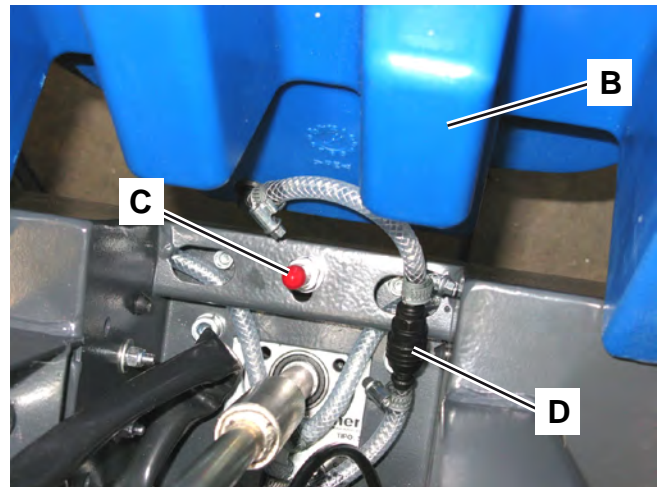
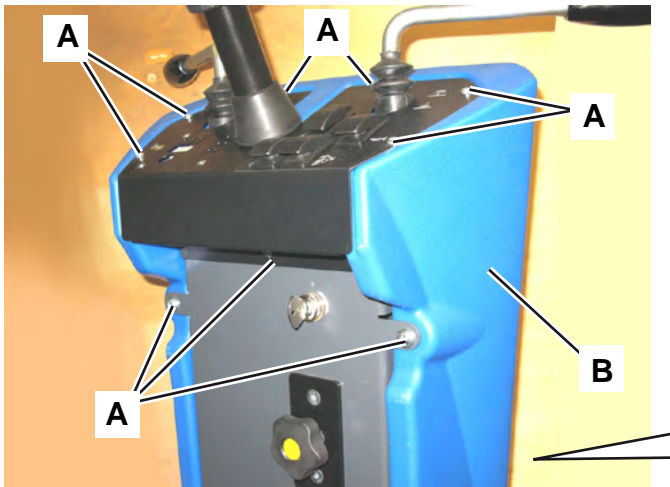

Main Broom Lifting Cable Disassembly/Assembly (Continues)

11. Unscrew the nut (I) and remove the pin (J).
12. Remove the screw (K).
13. Remove the locknut (L) and disconnect the tie rod (M) from the housing with cut (N).
14. Remove the pin (P).
15. In the left front lower side of the machine, unscrew the nut (Q) and disconnect the grommet (R) of the cable (S) to be removed.
16. Unscrew the locknut (T) and remove the cable (S) from the cut (U).
17. Unscrew the nut (V) and remove the screw (W).
18. Remove the cable (S) by disengaging it from the pulleys (X) and from the fastener (Y).

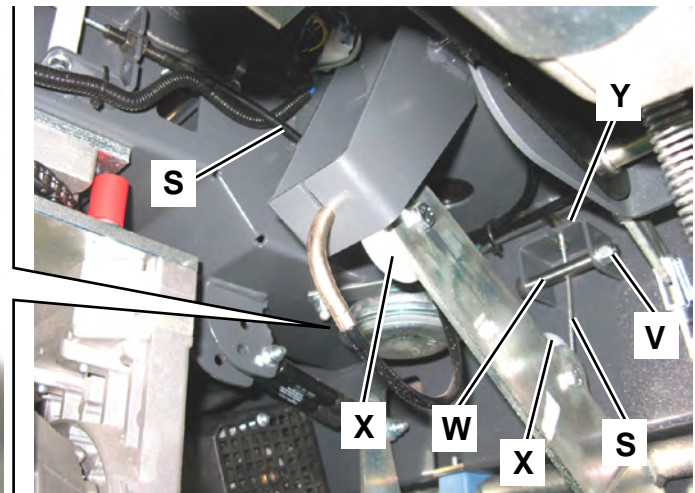
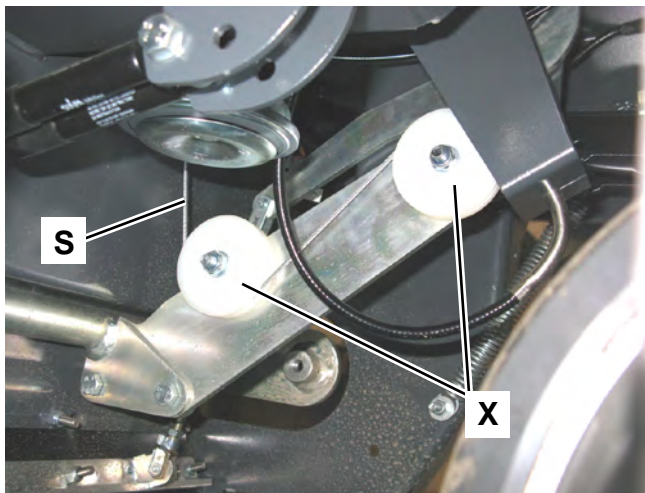
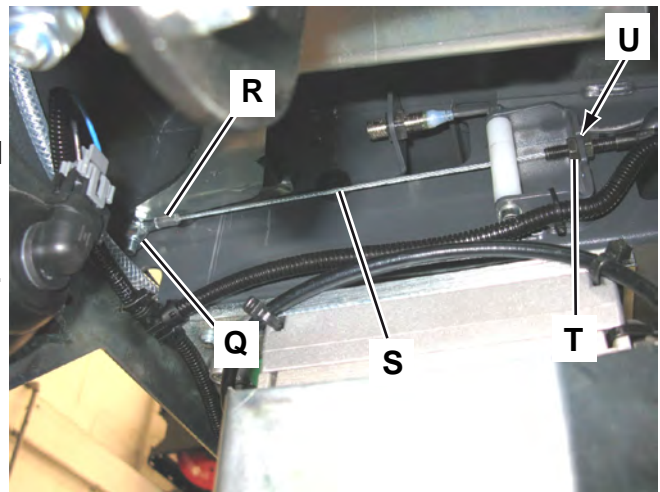
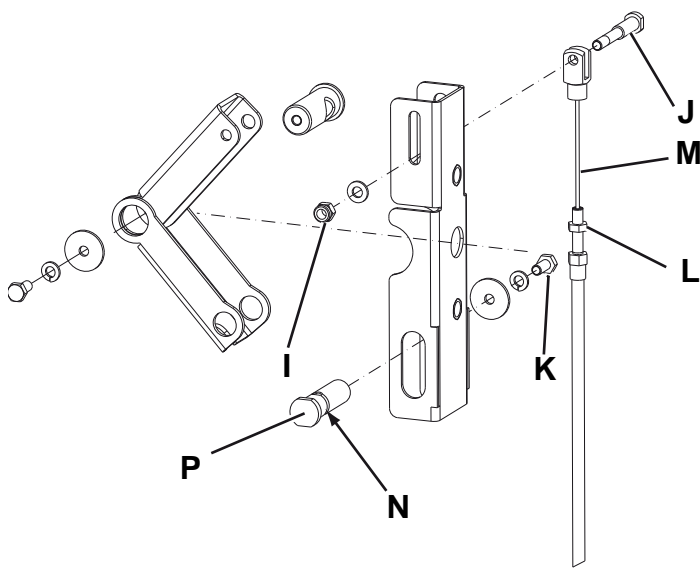

Main Broom Lifting Cable Disassembly/Assembly (Continues)

Assembly and Adjustment

19. Assemble the components in the reverse order of disassembly, and note the following:
 - Adjust the cable (S) as shown below:
20. Place the locknut (T) near the relevant nut, without tightening it.
21. Turn the handwheel (F) clockwise until the end of the stroke (the broom must be fully lifted).
22. Turn the main broom lifting/lowering lever to working position (lowered broom).
23. Remove the machine right door by turning the relevant fasteners.
24. Adjust the nut-locknut adjuster (T) to reach, on the machine right side, a distance (Z) of 165 mm from the main broom shaft centre to the ground.

After adjusting, tighten the nut-locknut adjuster (T).

25. Adjust the same distance of 165 mm (AA) from the main broom shaft centre to the ground, also on the machine left side; for the adjustment use the opposed adjusters with locknuts (AB).

After adjusting, tighten the locknuts (AB).

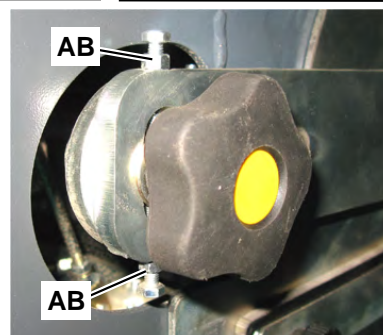
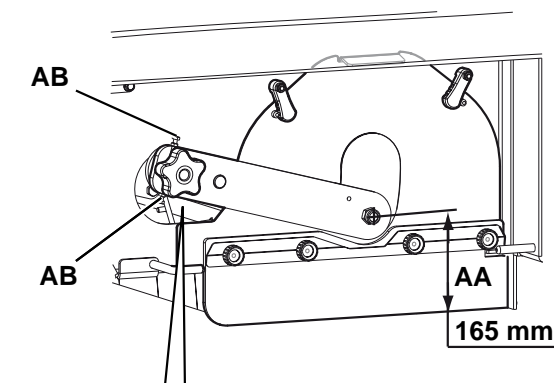
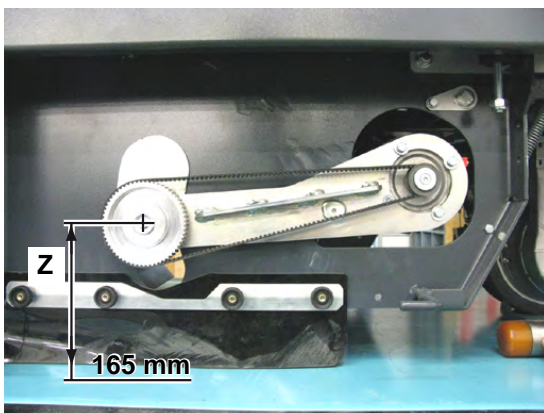
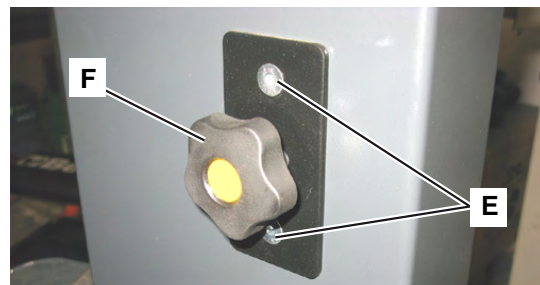
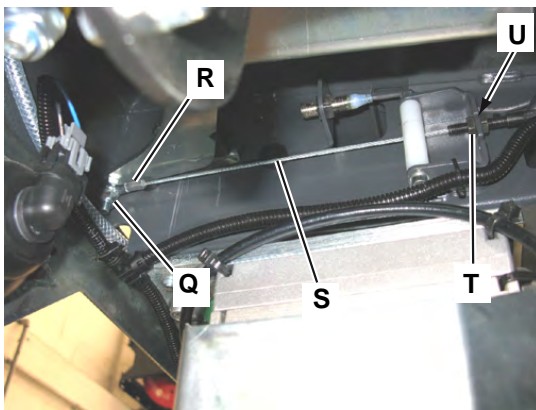

Lowered Main Broom Enabling Sensor Disassembly/Assembly and Adjustment

Disassembly

1. If possible, place the machine on a hoisting system.
2. Remove the left side broom, if equipped.
3. On the machine left lower front side, unscrew the locknut (A) and remove the enabling sensor (B) from its housing.
4. Disengage the sensor electrical cable (C) from its fasteners, then disconnect the relevant connector.
5. Retrieve the proximity sensor (B) with the electrical cable.

Assembly and Adjustment

6. Place the enabling sensor (B) and connect its connector, then engage the wiring harness from its fasteners.
7. Screw down the locknut (A), without tightening it.
8. Turn the main broom lifting/lowering lever to lower the broom.
9. Adjust the distance (D) between the sensor (B) and the pin (E) to 4 ± 1 mm, then tighten the locknut (A).
10. Install the left side broom, if equipped.

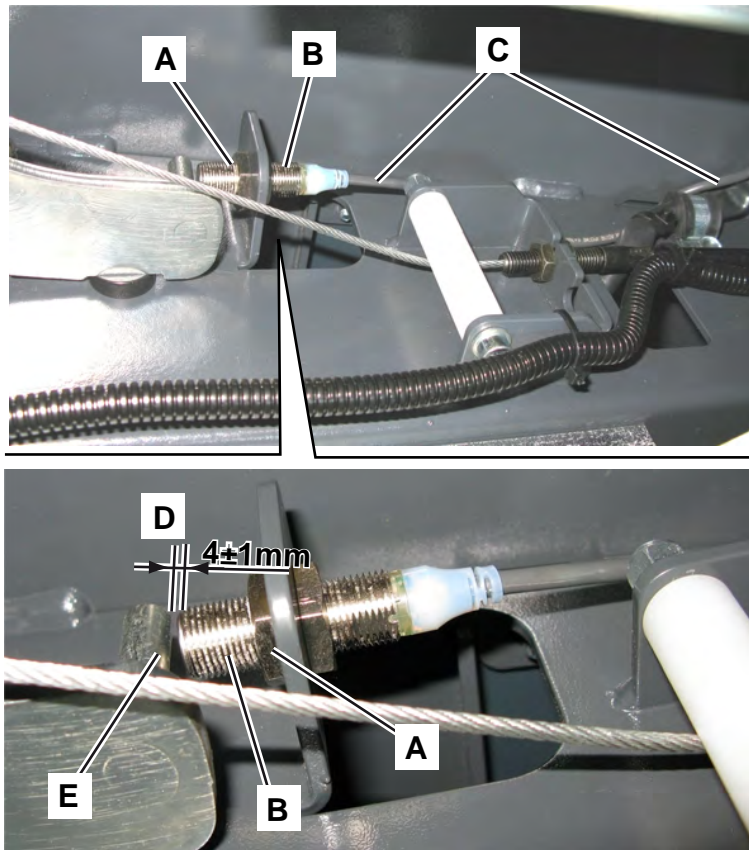

Specifications

Main Broom System	Values		
	SW4000 Battery	SW4000 Petrol	SW4000 LPG
Main broom size (length x diameter)	27.6 x 13.4 in (700 x 340 mm)		
Main broom motor	0.8 hp (600 W) - 550 rpm		
Gas spring pressure (Q.ty 2)	90 lb (400 N)		

Side Broom System

Functional Description

By using the right lever on the dashboard the side brooms lower, because they are released by a metal cable. In case of side impact, the system can return by means of a spring which absorbs the shock.

The broom is fastened to the reduction unit shaft with a safety pin.

The side broom motors turn only when the main broom is activated.

The side broom motors (right M6, left M7) are powered by the relay (K5) and protected by the resettable fuses (right FR1) and (left FR2).

The relay (K5) is activated directly by the sensor (S3) (side broom control lever position) only when the side broom is activated too.

Wiring Diagram

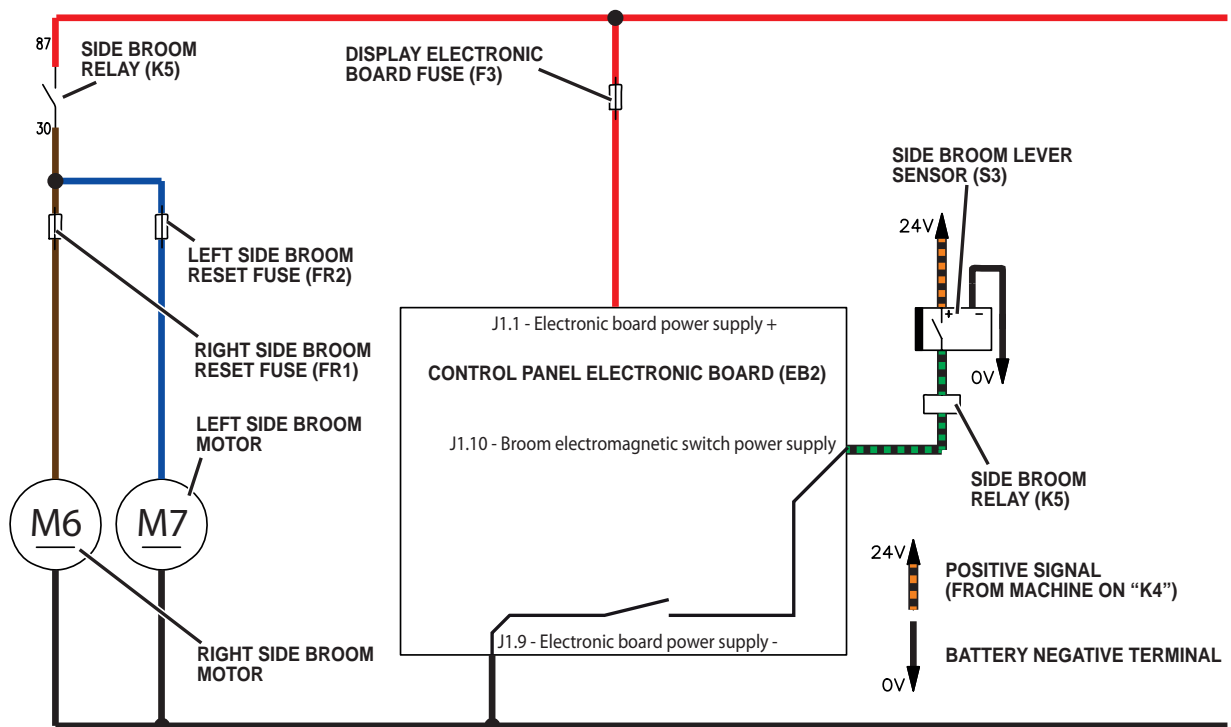

Component Locations

- Side broom lifting/lowering lever
- Broom height adjusting ring nuts
- Side broom motor (M6) (M7)
- Side broom
- Lowered right side broom enabling sensor (S3)
- Left side broom motor fuse (15 A) (FR1)
- Right side broom motor fuse (15 A) (FR2)



Side broom lifting/lowering lever

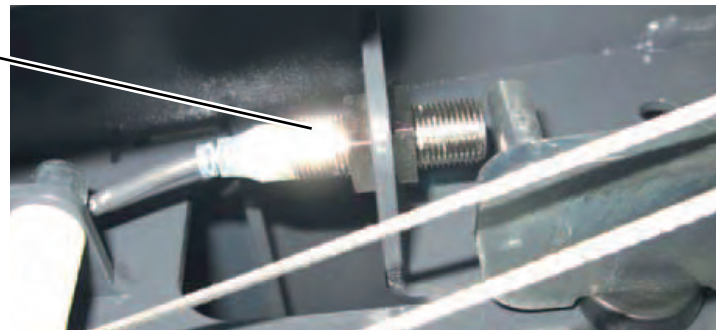

Lowered side broom enabling sensor (S3)



Broom height adjusting ring nuts

Side broom motor (M6) (M7)

Side broom

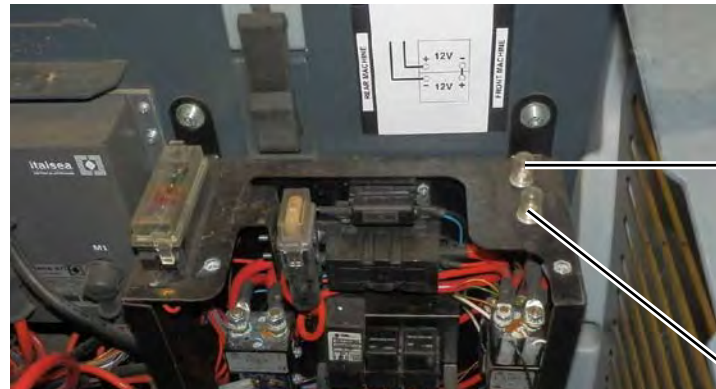

Left side broom motor fuse (15 A) (FR1)

Right side broom motor fuse (15 A) (FR2)

Maintenance and Adjustments

Side Broom Height Check and Adjustment



Note: Brooms with harder or softer bristles are available. This procedure is applicable to all types of brooms.

1. Check the side broom distance from the ground, according to the following procedure:
 - Drive the machine on a level floor.
 - Keep the machine stationary, lower the side brooms and turn them on for a few seconds.
 - Stop and lift the side brooms, then move the machine.
 - Check that the side broom prints are as shown in the figure (A and B).

If the print is not within specifications, adjust the side broom height according to the following procedure.

2. Engage the parking brake.
3. Turn the ignition key to “0”.

4. Turn the fasteners and remove the left or right door.
5. For the right side broom, operate on the idle gear by loosening the ring nut (C) and by adjusting the adjuster (D) until the correct print (A) is achieved. Finally lock the adjuster (D) into position with the ring nut (C).

For the left side broom, operate on the idle gear by loosening the ring nut (E) and by adjusting the adjuster (F) until the correct print (B) is achieved. Finally lock the adjuster (F) into position with the ring nut (E).

6. Perform step 1 again to check the proper adjustment of the side broom height.
7. When the broom is too worn and can no longer be adjusted, replace it according to the procedure shown in the relevant paragraph.

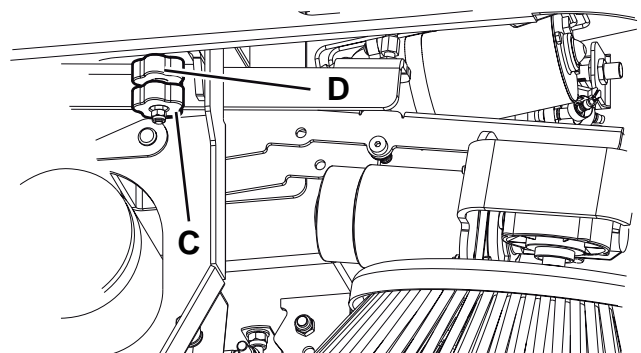
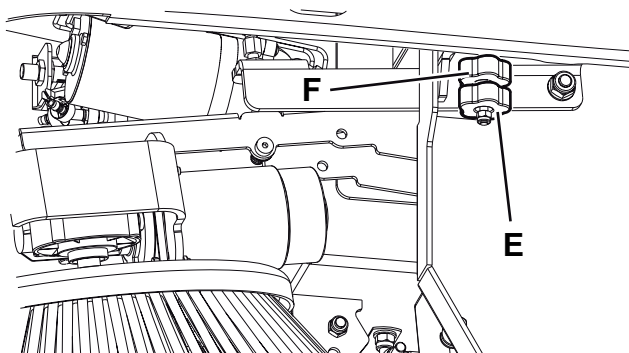
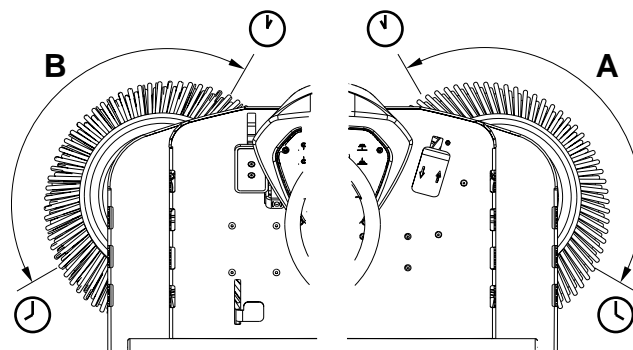

Troubleshooting

Trouble	Possible causes	Remedy
The right/left side broom does not clean properly	The broom has not been properly adjusted in height/parallelism	Adjust
	The broom is excessively worn	Replace
The side brooms do not work	The sensor is misadjusted or broken	Adjust/replace
	The motor (M6) or (M7) is faulty	Check the motor amperage/replace
	There are ropes or debris restraining the broom rotation	Remove and clean
	The side broom fuse (FR1) or (FR2) is open.	Wait for the side broom motor to cool down, then reset the fuse by pressing the relevant push-button.
	The relay (K5) is not efficient	Replace.

Removal and Installation

Side Broom Disassembly/Assembly



Note: Brooms with harder or softer bristles are available. This procedure is applicable to all types of brooms.



Warning! It is advisable to wear protective gloves when replacing the main broom because there can be sharp debris between the bristles.

Disassembly

1. Drive the machine on a level ground and engage the parking brake.
2. Turn the ignition key to “0”.
3. Lift the side broom with the lever.
4. Disengage the fastener and remove the pin (A).
5. Remove the side broom (B) from the hub (D) and retrieve the protection flange (C).

Assembly

6. Install the protection flange (C) on the hub (D) and the side broom (B).
7. Insert the pin (A) and engage its fastener.
8. Check the side broom height.

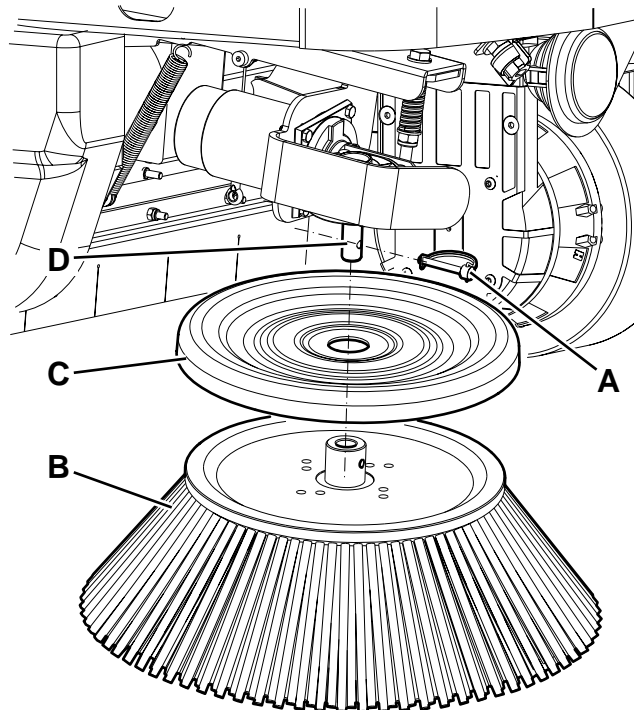

Side Broom Motor Amperage Check



Warning! This procedure must be performed by qualified personnel only.

1. Remove the side broom of the relevant motor.
2. Place wedges (A) on the rear wheels of the machine.
3. With a proper hoisting system applied to the machine chassis, to the front wheel area (B), lift the machine a few centimetres, in order to let the front wheel turn freely without touching the floor.
4. Apply amp clamps (C) on a cable (D) of the broom motor (E).
5. Turn the ignition key to “I”.
6. Turn on the side broom and check that the amperage of the motor (E) is 1.5 - 2 A at 24 V.

Stop the side broom rotation.

Turn the ignition key to “0”.

Remove the amp clamps (C).

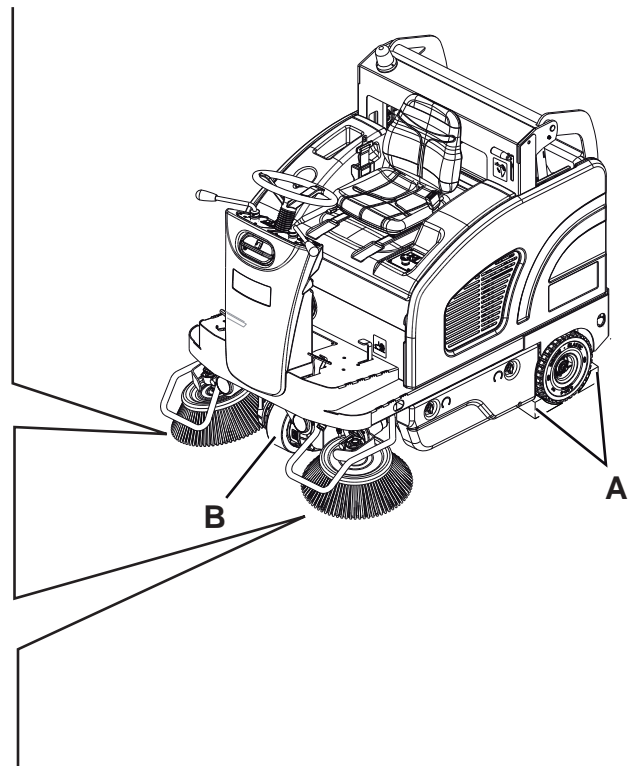
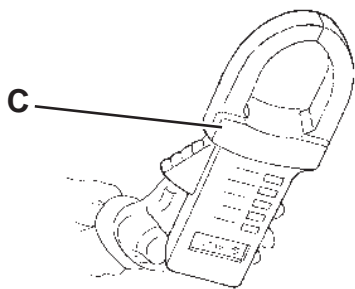
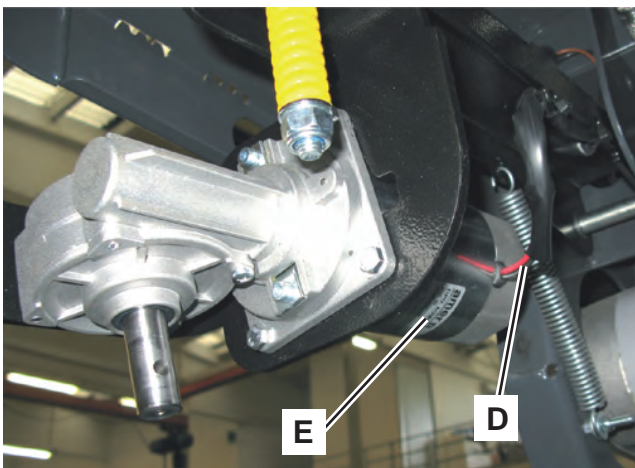

Side Broom Motor Amperage Check (Continues)

If the amperage is higher, perform the following procedures to detect and correct it:

- Check if there is dust or dirt (cords, cables, etc.) on the side broom hub.
- Check the motor carbon brushes (see the procedure in “Side Broom Motor Carbon Brush Check/Replacement”).
- If necessary, disassemble the motor (see procedure in the next paragraph), and check the condition of all its components.

If the above-mentioned procedures do not lead to a correct amperage, the motor must be replaced (see the procedure in the relevant paragraph).

Reassembly

7. Install the side broom of the relevant motor.
8. Remove the front hoisting system of the machine.
9. Remove the wedges from the rear wheels.

Side Broom Motor Disassembly/Assembly

Disassembly

1. Remove the side broom of the motor to be detached.
2. Lower the side broom with the lever.
3. Disconnect the connector (A) of the broom motor (B).
4. Remove the four screws with nut (C).
5. Remove the broom motor (B).

Assembly

6. Assemble the components in the reverse order of disassembly.
7. Perform the side broom height check and adjustment.

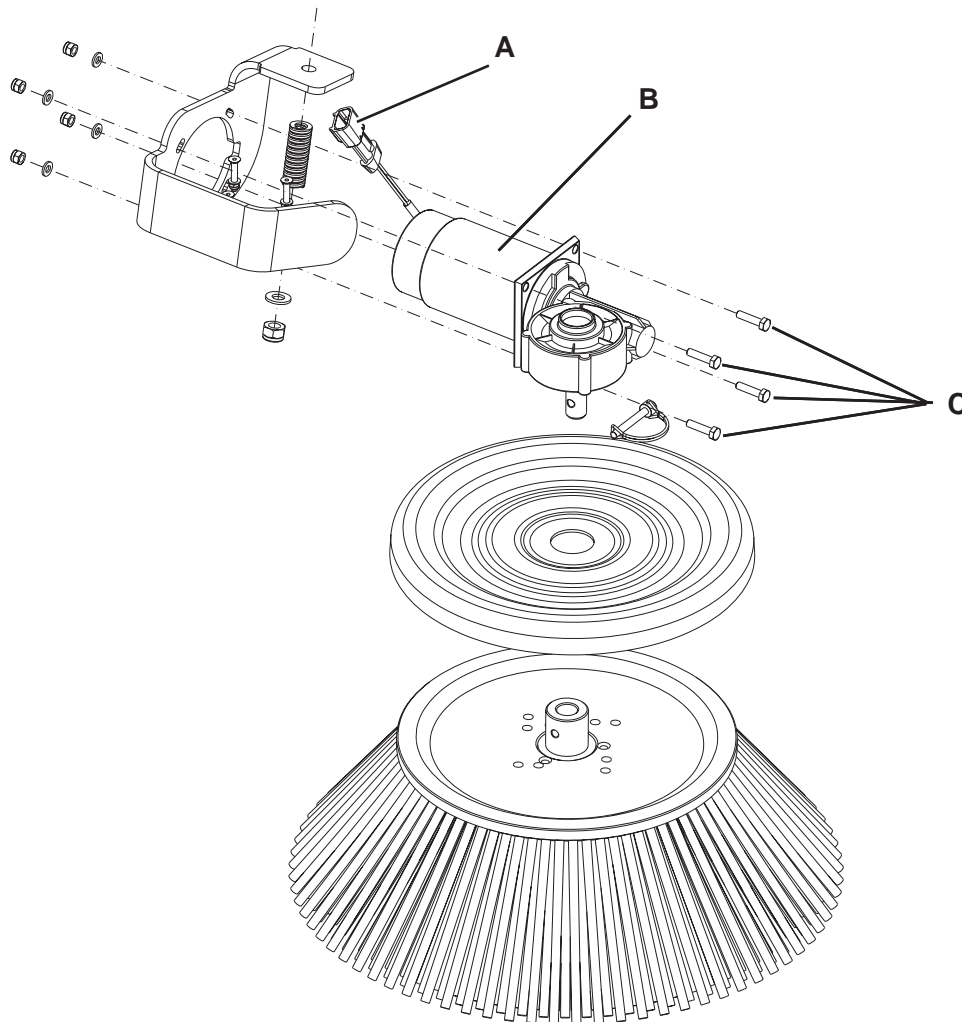

Side Broom Motor Carbon Brush Check/Replacement

Disassembly

1. Remove the side broom motor (see the procedure in the previous paragraph).
2. Take the motor (A) to the workbench and, if necessary, mark the position (B) of the cap (C) as to the motor body (for proper reassembly).
3. Remove the screws (D).
4. Carefully remove the cap (C) by disengaging the carbon brushes inside the motor armature.
5. Inside the cap, disconnect the connections (E) and remove the carbon brushes with wiring harness (F).
6. Check the carbon brushes (F) for wear. The carbon brushes are worn when:
 - The contact with the motor armature is insufficient
 - The contact surface is not integral
 - The stroke is less than 0.12 in (3 mm)
 - The spring is broken

In this cases, replace all motor carbon brushes.

Assembly

7. Assemble the components in the reverse order of disassembly.

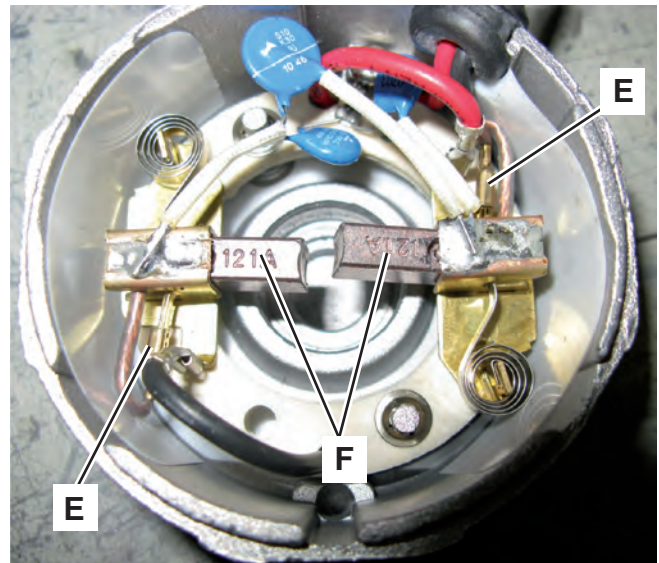
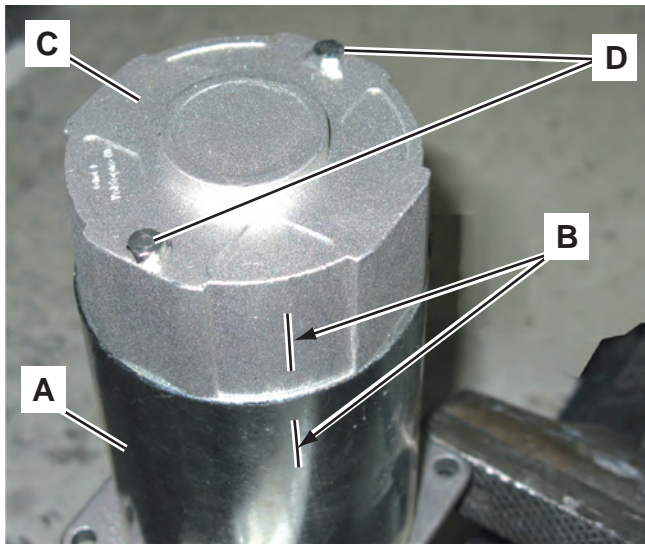

P200190

Side Broom Lifting Cable Disassembly/Assembly

Disassembly

1. If possible, place the machine on a hoisting system.
2. Remove the relevant side broom.
3. Above the side broom motor, remove the screw with nut (A) and release the grommet (B) of the cable (C) to be removed.
4. Unscrew the locknut (E) and remove the cable (C) from the cut (D).

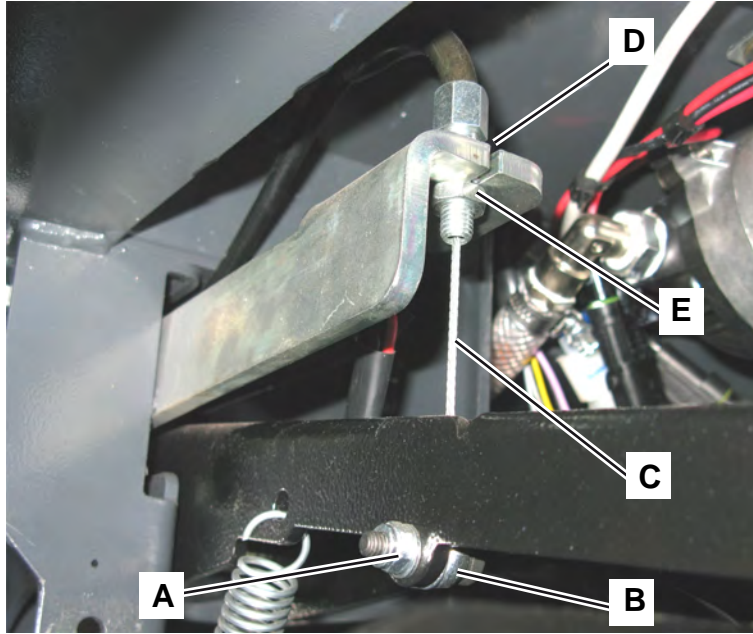

P200191

Side Broom Lifting Cable Disassembly/Assembly (Continues)

5. On the other cable terminal (C), remove the screw with nut (G) and release the relevant grommet (F) of the cable (C) to be removed.
6. Unscrew the locknut (H) and remove the cable (C) from the cut (I).
7. Retrieve the cable (C).

Assembly

8. Assemble the components in the reverse order of disassembly, and note the following:
 - Adjust the position of nuts/locknuts (E) and (H) until the proper side broom height is reached, by keeping the adjusters (J) in an intermediate position.

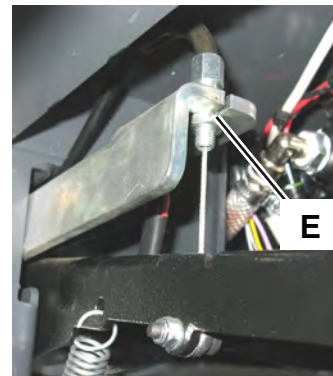
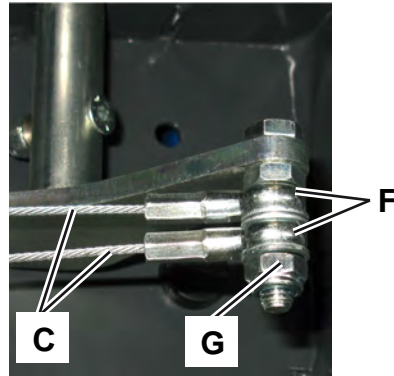
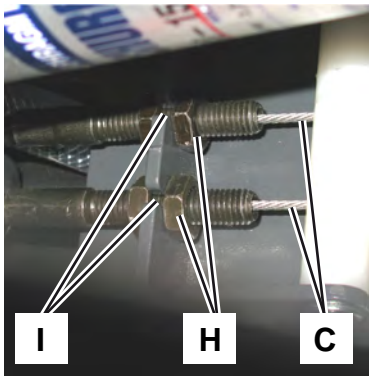
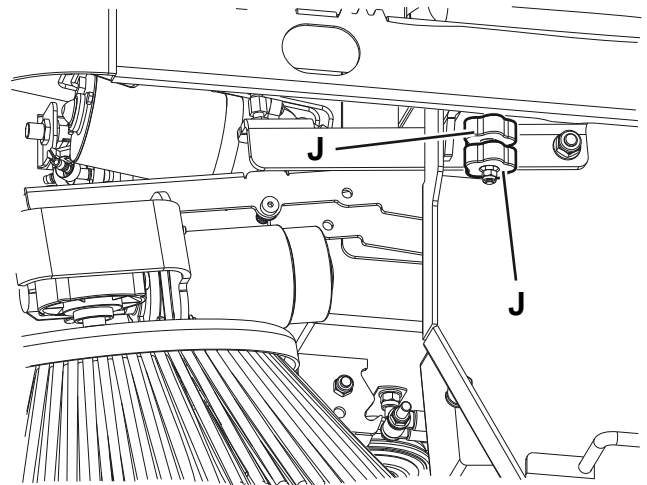
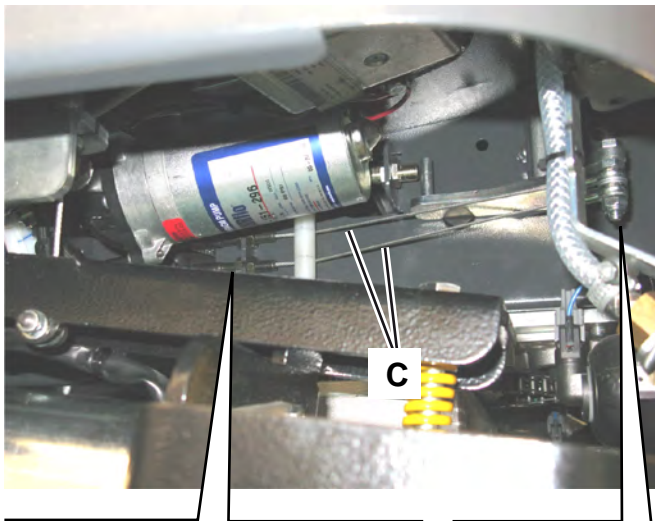

Lowered Right Side Broom Enabling Sensor Disassembly/Assembly and Adjustment

Disassembly

1. If possible, place the machine on a hoisting system.
2. Remove the right side broom.
3. On the right front lower side of the machine, unscrew the locknut (A) and remove the enabling sensor (B) from its housing.
4. Disengage the sensor electrical cable (C) from its fasteners, then disconnect the relevant connector.
5. Retrieve the enabling sensor (B) with the electrical cable.

Assembly and Adjustment

6. Place the enabling sensor (B) and connect its connector, then engage the wiring harness from its fasteners.
7. Screw down the locknut (A), without tightening it.
8. Turn the side broom lifting/lowering lever to lower the brooms.
9. Adjust the distance (D) between the sensor (B) and the pin (E) to 4 ± 1 mm, then tighten the locknut (A).
10. Install the right side broom.

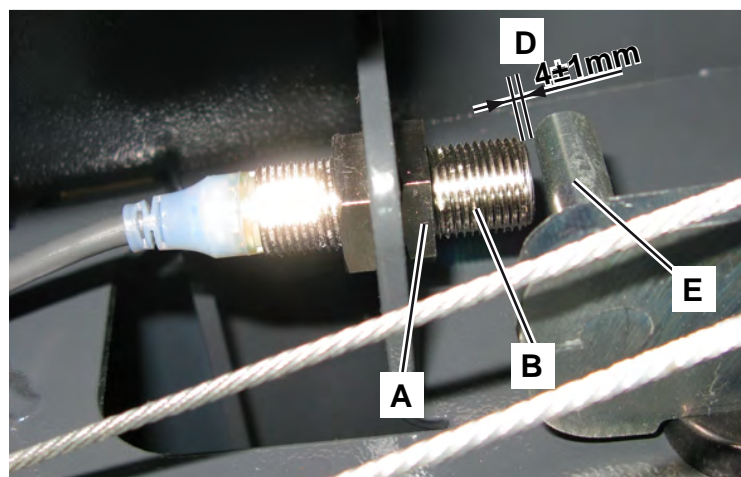
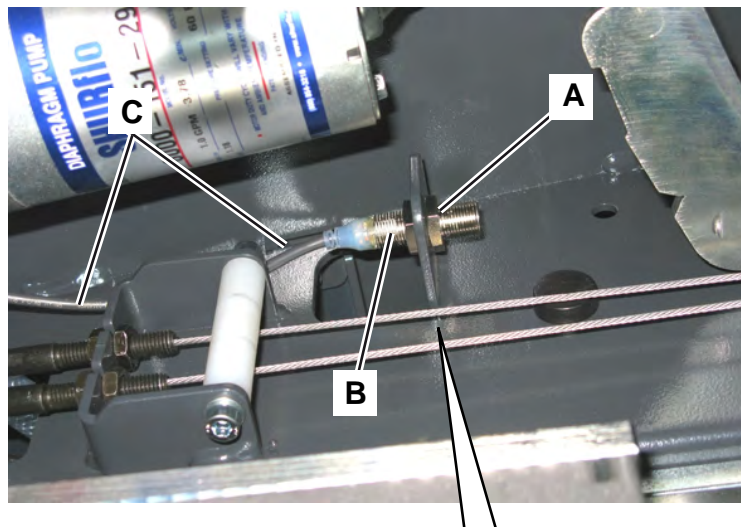

Specifications

Side Broom System	Values		
	SW4000 Battery	SW4000 Petrol	SW4000 LPG
Working width (with one side broom)	38.3 in (975 mm)		
Working width (with two side brooms)	49.2 in (1,250 mm)		
Side broom diameter	17.7 in (450 mm)		
Side broom reduction unit	0.12 hp (90 W) - 110 rpm		

Wheel System, Non-Traction

Functional Description

The rear wheels turn freely without any drive or stop system.

These are held in place by means of a pin on eccentric flange, fastened to the chassis by means of screws.

On SW4000 Battery, only super elastic wheels are available.

On SW4000 Petrol/LPG, polyurethane wheels are standard and super elastic wheels are optional.

For both polyurethane and super elastic wheels, the non-marking version is available.

On the lower part of the chassis, near the flange, there are the letters “S” and “P” to be taken as a reference for the positioning notch on the support flange of each wheel.

(Only for SW4000 Petrol/LPG). In case of super elastic wheels, the notch on the wheel support flange must be placed near the letter “S”; in case of polyurethane wheels the notch must be placed near the letter “P”.

Component Locations

- Rear wheels
- Hub
- Hexagon castle nut

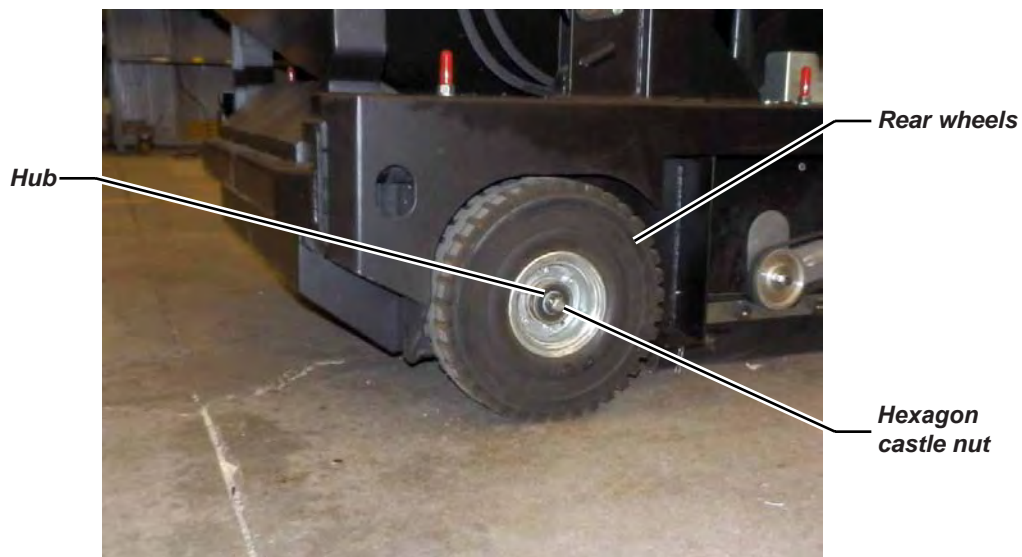

Specifications

Wheel System, Non Traction	Values		
	SW4000 Battery	SW4000 Petrol	SW4000 LPG
Rear axle kerb weight	860 lb (390 Kg)	672 lb (305 Kg)	670 lb (304 Kg)
Rear wheel specific pressure on the floor	102 psi (0.7 N/mm ²)	73 psi (0.5 N/mm ²)	
Rear wheels (diameter x length)	12.2 x 3.8 in (310 x 96 mm)		

Wheel System, Traction

Functional Description

The main components for the drive system are: the driving wheel assembly with integrated disc brake, the drive pedal, the electronic board, forward/reverse gear switch and the brake pedal with parking brake lever. The direction of travel is defined by the switch on the dashboard. If the switch is set to reverse, the reverse gear buzzer starts to sound until the forward gear is not restored.

On the driving wheel there is a disc brake keyed to a reduction unit fast shaft.

The brake pedal activates the disc brake piston with a sheathed cable. The parking brake lever mechanism is integrated in the brake pedal.

The driving wheel (M0) is powered by the drive system control electronic board (EB1).

The driving wheel is electronically protected by the drive system control electronic board (EB1), which limits the current supplied at the values set in the relevant parameters (see parameters 19, 20, 21 in Drive System Electronic Board Parameter Table).

The electronic board power circuit (EB1) is powered through the safety electromagnetic switch (ES0).

The electromagnetic switch (ES0) is activated by the same electronic board (EB1), after the first check on the conformity of the input conditions, when it receives the start-up signal by the ignition switch circuit (SW1) through the relay (K4).

The main control inputs of the electronic board (EB1) are the hall-effect pedal (R1) and the forward/reverse gear switch (SW2).

Other inputs of the electronic board (EB1) are: the driver's seat microswitch (SW7) and the lifted hopper sensor (S1) signal. The drive system is inhibited when the microswitch (SW7) does not detect the operator on the driver's seat, but when the sensor (S1) detects that the hopper is lifted, the maximum machine speed is decreased to a safety value (see parameter 12, in Drive System Electronic Board Parameter Table).

Upon start-up (with the ignition switch SW1) or when the driver's seat microswitch signal (SW7) is interrupted and then restored, the system is always set to forward speed. Pressing the forward/reverse gear switch (SW2) changes to reverse gear until the switch is pressed again. When the reverse gear is selected, the warning light on the switch (SW2) and the buzzer (BZ1) turn on.

The position of the drive pedal (R1) determines the machine speed. The safety condition for drive system activation is that the drive pedal (R1) is totally released (machine stopped) when the system is turned on (with the ignition switch SW1).

When the machine is stopped, the output signal for R1 is less than 1V.

When the machine reaches the maximum speed, the output signal for R1 is higher than 5V.

This calibration should be correct for 100% of pedals. Otherwise, if a different pedal calibration is necessary, perform the following learning procedure for the electronic board:

1. Connect the programmer (9097297000) and enter the potentiometer calibration enabling page
2. Confirm by pressing the MODE key
3. Release the pedal and confirm by pressing the MODE key
4. Press the pedal until the end of stroke (max. speed) and confirm by pressing the MODE key

If the electronic board detects a fault in the drive system, this will appear as a code on the display and the malfunction warning light (A) on the electronic board (EB2) will turn on. The error code is a number of flashes of the malfunction warning light (A), which is repeated until reset by ignition switch (SW1).

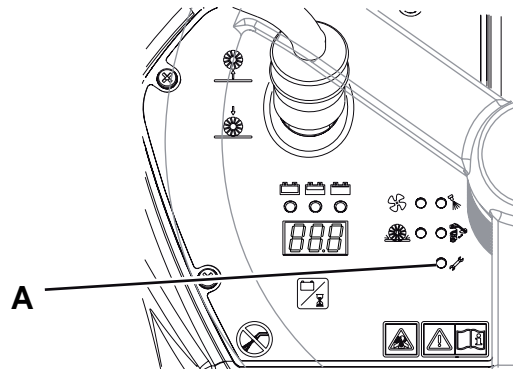

P200195

Wiring Diagram

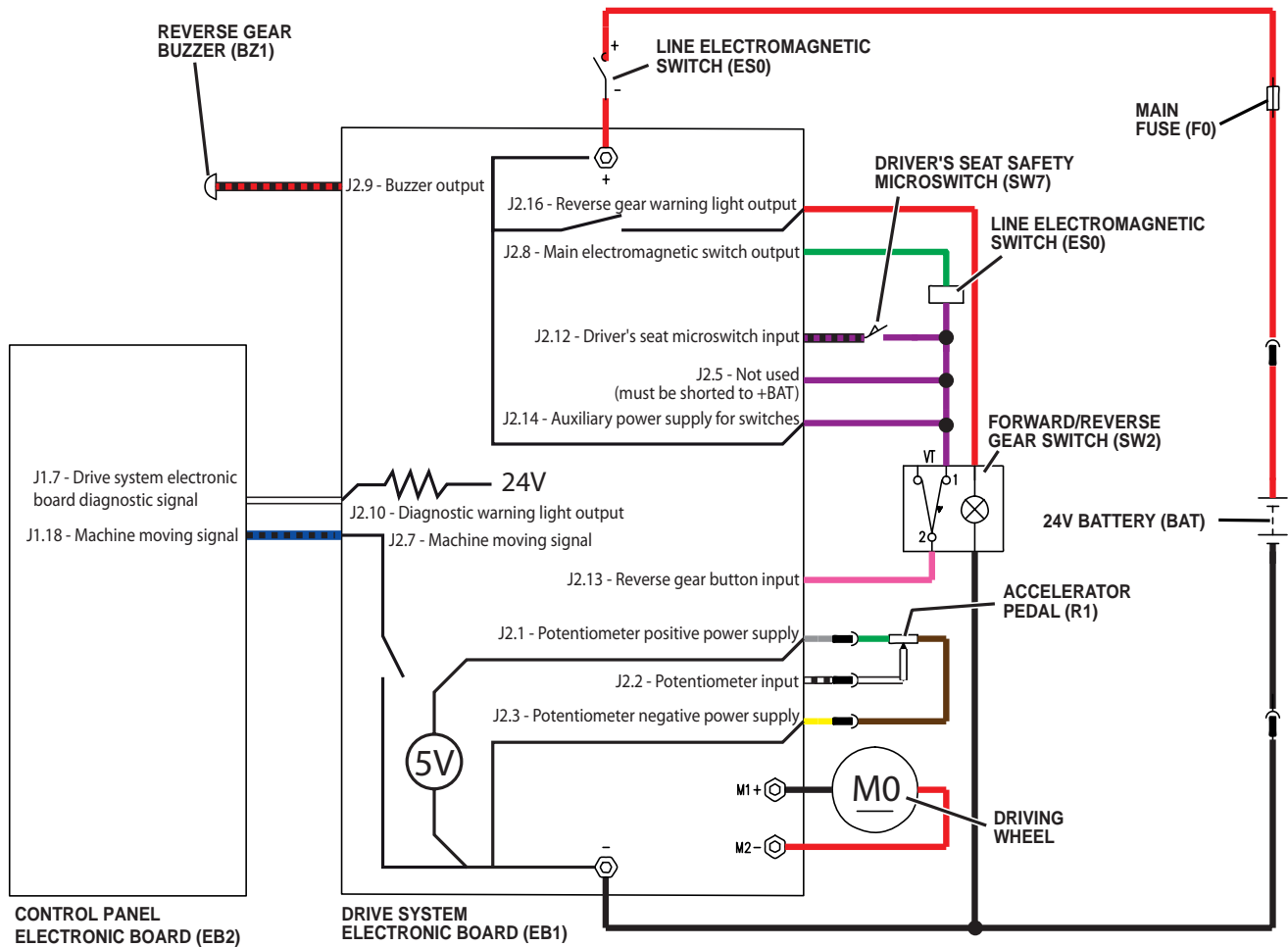

P200196

Component Locations

- Forward/reverse gear switch (SW2)
- Drive system malfunction warning light
- Driver's seat safety microswitch (SW7)
- Service brake pedal
- Parking brake lever
- Drive pedal (R1)

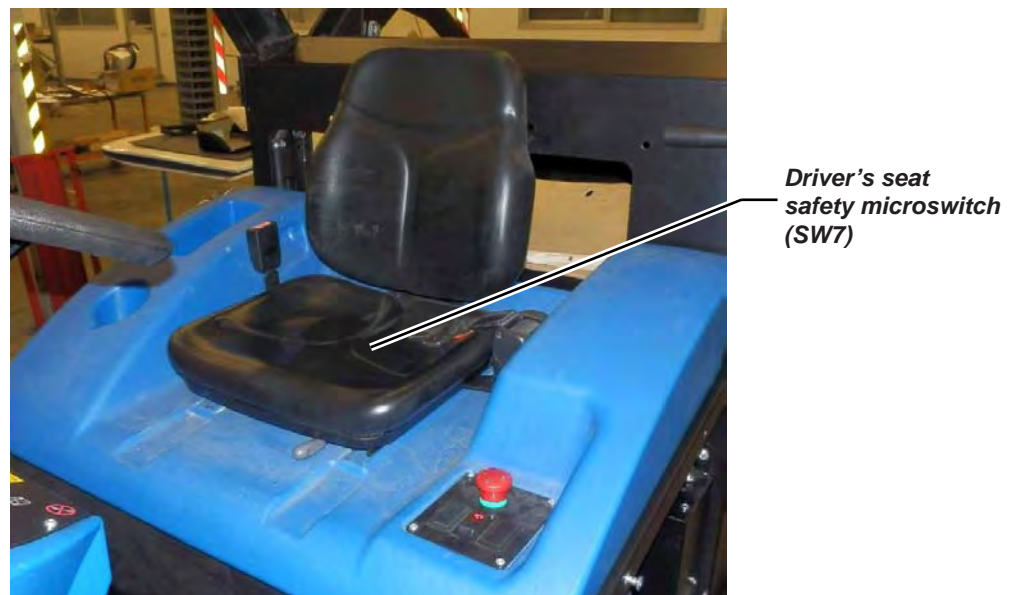

Component Locations (Continues)

- Driving wheel (M0)
- Disc brake
- Drive system electronic board (EB1)
- Main fuse (150 A) (F0)
- Reverse gear buzzer (BZ1)

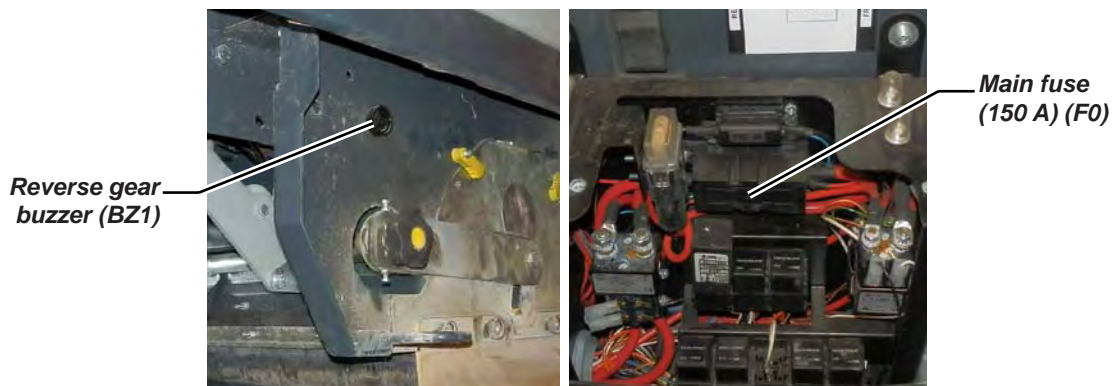
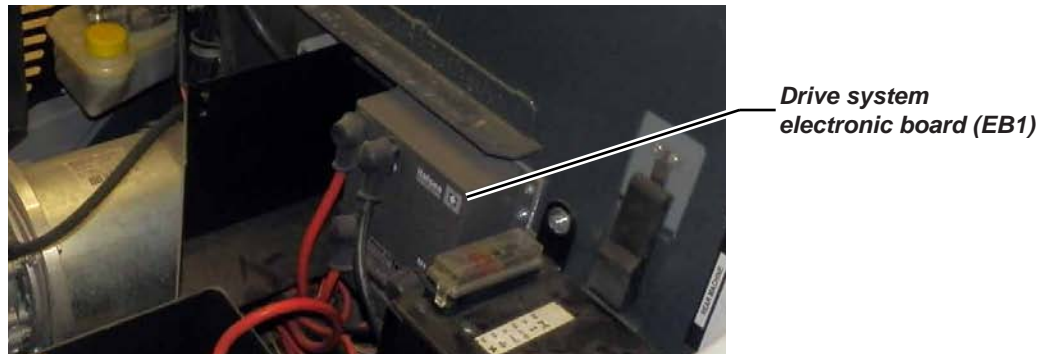
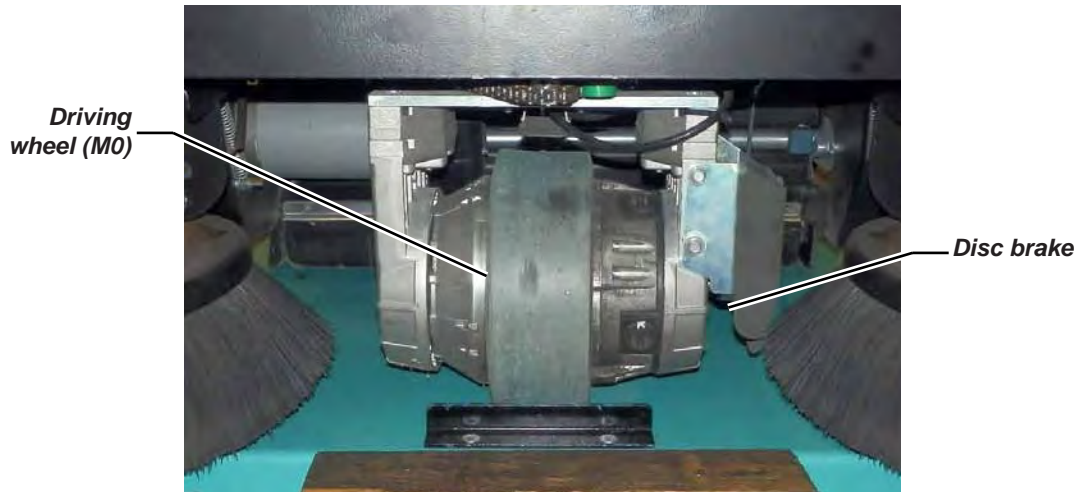

Troubleshooting

Trouble	Possible causes	Remedy
The machine does not move	The batteries are discharged or its connections are not efficient	Charge the batteries or clean/repair the connections
	The drive pedal control assembly (R1) is broken	Replace
	The drive system electronic board (EB1) is faulty	Replace
	The wiring harness is damaged	Check the electrical connections/repair the wiring harness
	The carbon brushes of the driving wheel (M0) are worn/damaged	Replace the carbon brushes/replace the driving wheel
	The ignition key (SW1) is not working	Replace
	The driver's seat safety microswitch (SW7) is broken	Replace
The brake does not operate	The braking masses are worn	Replace
	The brake cable is misadjusted	Adjust it
The machine does not move when pressing the drive pedal and the drive system warning light (red) flashes.	The drive pedal has been pressed before or at machine start-up.	Start up the machine without pressing the drive pedal.
	Drive system failure.	Turn off the machine and then turn it on again. If the trouble persists, contact the Service Center.

Drive System Electronic Board Error Codes Table

No. of flashes of the warning light (A)	MEANING	FIRST PROCEDURE	IF THE PROBLEM PERSISTS
2	Not active	-	-
3	Potentiometer wiring harness error	Check the pedal wiring harness R1	Repair the wiring harness or replace the pedal
4	Potentiometer activated at start-up	Check that the pedal is not pressed (the potentiometer output must be <1V as to the battery negative terminal)	Replace the pedal or perform the calibration procedures described above
5	Thermal protection	Allow the electronic board to reduce the inner temperature while leaving the machine stopped for a few minutes	Check the amperage of the driving wheel
6	Damaged power stage	Replace the EB1 electronic board	-
7	Overcurrent	Check the amperage of the driving wheel	-
8	Open external electromagnetic switch	Check the ES0 electromagnetic switch operation and the electronic board power wiring harness integrity.	Replace the EB1 electronic board
9	Undervoltage	Check the battery voltage	Replace the damaged batteries
10	Overvoltage	Check the battery voltage and the power connection tightening	-
11	Amperometric protection	Check the amperage of the driving wheel	-
12	Not active	-	-
13	Switching off sequence detected	Check the machine switch on control wiring harness from SW0 to SW1 to K4	Replace SW0, SW1, K4.
14	EEPROM error	Switch on the machine again	Replace the EB1 electronic board

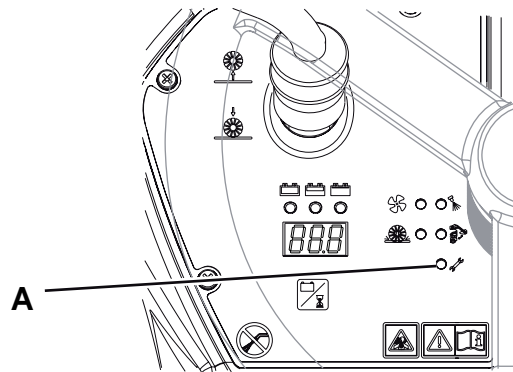

Drive System Electronic Board Parameter Table

The drive system electronic board software contains some parameters which can be modified by the user with the ITALSEA programmer (P/N 9097297000).

PAR	PARAMETER	DEFAULT	NOTE
1	RESET TO DEFAULT PARAMETERS	OFF	Turn to ON to reset all default values
2	ACCELERATION RAMP	3.0	Time (Sec) to accelerate from 0 to the maximum speed. Decrease to have a better response from the system, increase to have a less aggressive behaviour
3	REVERSE DECELERATION RAMP	0.8	Time (Sec) to decelerate from the maximum speed to 0 in case of reversing the gear.
4	NEUTRAL DECELERATION RAMP	0.8	Time (Sec) to decelerate from the maximum speed to 0 in case the pedal is suddenly released. WARNING! When this value is increased, the machine braking distance is increased too, when the service brake is not applied.
5	FORWARD MAXIMUM SPEED	100	Maximum forward speed (%)
6	BACKWARD MAXIMUM SPEED	60	Maximum reverse speed (%)
7	MINIMUM SPEED	0	Not active
8	BATTERY VOLTAGE	24	Battery rated voltage value (DO NOT MODIFY!)
9	SPEED REFERENCE	SINGLE ENDED	Pedal type (DO NOT MODIFY!)
10	REFERENCE DEAD-BAND	0.00	Not active
11	BRAKE DELAY	2.0	Delay (sec) at which the electronic board sends the “machine stopped” signal to EB2 after the machine has been stopped. It is used by EB2 to stop the components (brooms, vacuum system, dust guard system) when the machine is stopped.
12	SPEED IN MULTIMODE	50	Maximum speed (%) when the hopper is lifted
13	CURRENT IN MULTIMODE	250	Maximum current (Amp) available (peak value) when the hopper is lifted
14	BACKWARD SAFETY TIME	0.0	Not active
15	BACKWARD SAFETY SPEED	0	Not active
16	LOW BATTERY LIMIT	17	Safety limit for discharged batteries (V). It inhibits the drive system when the battery voltage drops below this threshold.
17	RXL FUNCTION	0	Not active
18	RUN-AWAY FUNCTION	0	Not active
19	CONTROLLER'S CURRENT LIMIT	250	Maximum current (Amp) available (peak value) It can be reduced to prevent the machine from travelling on excessive slopes (rising)
20	MOTOR'S RATED CURRENT	50	Maximum current (Amp) available (continuous value) WARNING! When increasing this value, the risk of driving wheel overheating is increased too, in case of use on excessive slopes.
21	MOTOR'S OVERLOAD TIME	60	Maximum time (sec) during which the electronic board can supply a current higher than the value of parameter 20. WARNING! When increasing this value, the risk of driving wheel overheating is increased too, in case of use on excessive slopes.
22	PIN 5-J1 HARDWARE CONFIGURATION	N.C. SWITCH	Parameter connected to the hardware configuration (DO NOT MODIFY!)
23	PIN 6-J1 HARDWARE CONFIGURATION	N.O. SWITCH	Parameter connected to the hardware configuration (DO NOT MODIFY!)

PAR	PARAMETER	DEFAULT	NOTE
24	PIN 11-J1 HARDWARE CONFIGURATION	N.C. SWITCH	Parameter connected to the hardware configuration (DO NOT MODIFY!)
25	A1 ALARM ENABLING	DISABLE	Parameter connected to the hardware configuration (DO NOT MODIFY!)
26	A2 ALARM ENABLING	DISABLE	Parameter connected to the hardware configuration (DO NOT MODIFY!)
27	A3 ALARM ENABLING	ENABLE	Parameter connected to the hardware configuration (DO NOT MODIFY!)
28	A4 ALARM ENABLING	ENABLE	Parameter connected to the hardware configuration (DO NOT MODIFY!)
29	A12 ALARM ENABLING	DISABLE	Parameter connected to the hardware configuration (DO NOT MODIFY!)

Connectors on Drive System Electronic Board

Power Connections - Battery

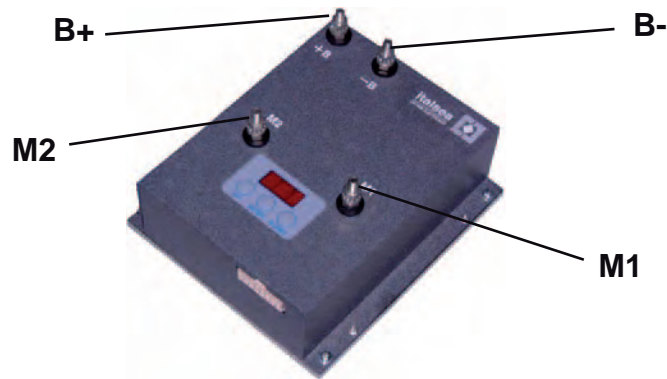

Power Connections (male screw terminals M 6)					
Ref.	Description	Electronic board in/out	V ref.	I max.	Connected to
B+	Electronic board power supply +	in	24V	250A	BAT+, ES0
B-	Electronic board power supply -	in	0V	250A	BAT-
M1	Drive system motor +	out	0 - 24V	250A	M0+
M2	Drive system motor -	out	0 - 24V	250A	M0-

J2: MOLEX MINIFIT type, 16-ways vertical

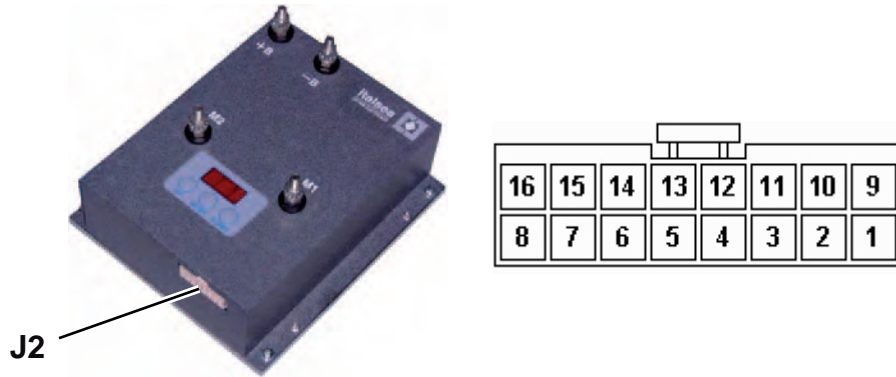

PIN	Description	Electronic board in/out	V ref.	I max.	Connected to
1	Potentiometer positive power supply	out	5V	<1A	R1
2	Potentiometer input	in	0 - 5V (0V when the pedal is released 5V when the pedal is pressed)	<1A	R1
3	Potentiometer negative power supply	in	0V	<1A	R1
4	Not used	-	-	-	-
5	Not used (must be shorted to +BAT)	in	24V	<1A	J2.14
6	Not used	-	-	-	-
7	Machine moving signal	out	24V (when the machine is moving)	<1A	EB2, J1.18
8	Main electromagnetic switch output	out	0V (when the machine is ON)	1A	ES0
9	Buzzer output	out	24V (when the buzzer is active)	1A	BZ1
10	Diagnostic warning light output	out	24V (when the light is active)	<1A	EB2, J1.7
11	Lifted hopper input	in	24V (when the hopper is lifted)	<1A	S1
12	Driver's seat microswitch input	in	24V (when the micro is pressed)	<1A	SW7
13	Reverse gear push-button input	in	24V (when the button is pressed)	<1A	SW2
14	Auxiliary power supply for switches	out	24V	<1A	ES0, SW2
15	Key input	in	24V (when the key is position I)	<1A	K4
16	Reverse gear warning light output	out	24V (when the reverse is active)	<1A	SW2

Removal and Installation

Brake Caliper, Pad, Brake Disc Disassembly/Assembly

Disassembly

1. Drive the machine on a level floor.
2. Turn the ignition key to “0”. Ensure that the machine cannot move by placing opposite wedges on the rear wheels.
3. Steer the front wheel to the right, about 90°.
4. Unscrew nut and locknut (A) then remove the brake cable (B) from the brackets (C). Retrieve the spring (D).
5. Remove the nuts (E).
6. Unscrew the nuts (F) and then remove the bracket assembly with outer pad (G).
7. Remove the springs (H).
8. Remove the brake disc (I). If necessary, retrieve the relevant key.
9. Remove the inner pad (L).

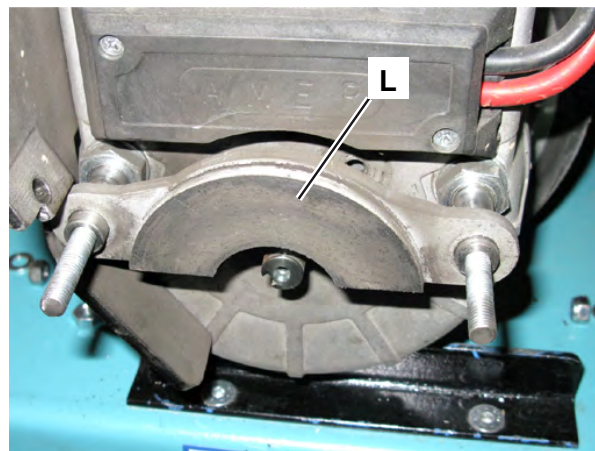
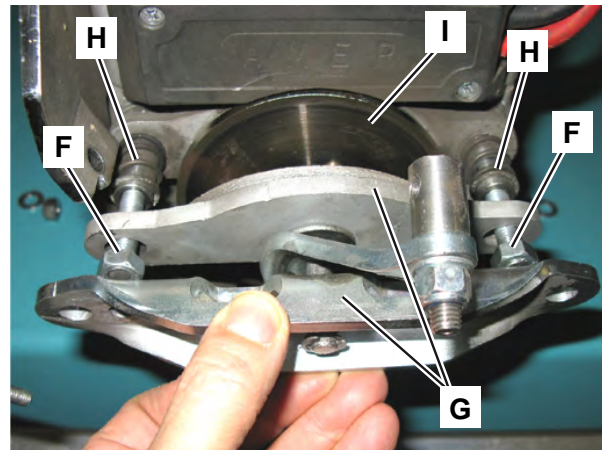
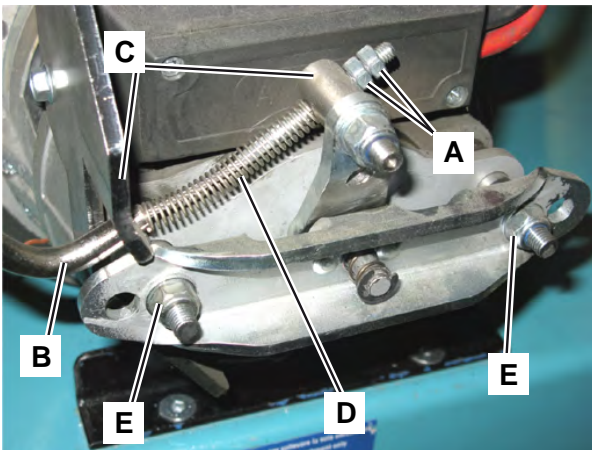

Brake Caliper, Pad, Brake Disc Disassembly/Assembly (Continues)

10. If necessary, separate the outer pad (M) from the bracket (N), as shown below:

- Disengage the retaining ring (O) and remove the spring (P).
- Remove the bracket (N) and the lever (Q).
- Retrieve the washer (R).
- Retrieve the inner pad (M).

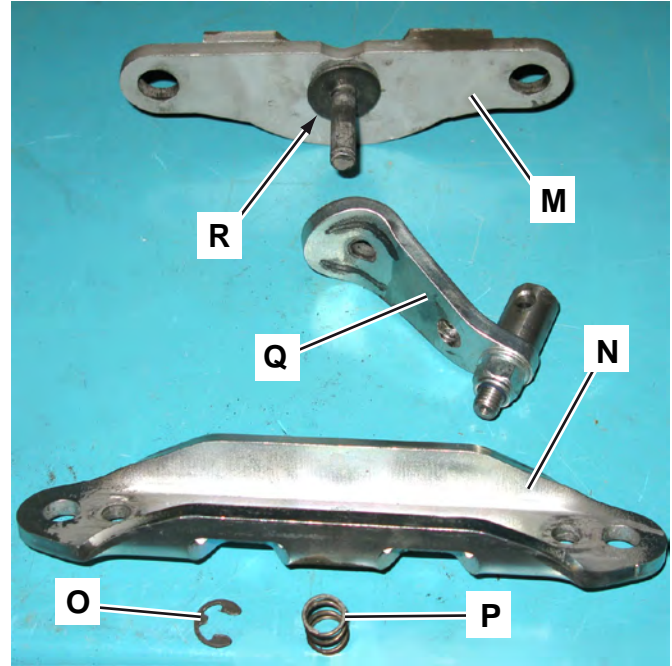
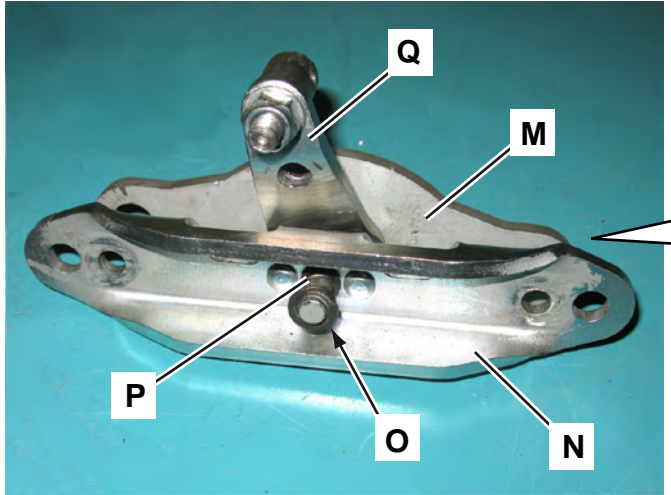

P200199

Brake Caliper, Pad, Brake Disc Disassembly/Assembly (Continues)

Assembly

11. Assemble the components in the reverse order of disassembly, and note the following:
 - Adjust the position of the nuts (F) until the bracket (G) comes into contact with the brake disc (I) and with the inner pad (L); then, unscrew the nuts (F) for 3/4 of a turn, thus giving a 1 mm clearance between the brake disc (I) and the pads (L) and (M). Also check the parallelism of the bracket (G) with the fixed part, by equating the two portions (N).
 - Screw down and tighten the nuts (E).
12. Adjust the brake according to the following procedure.

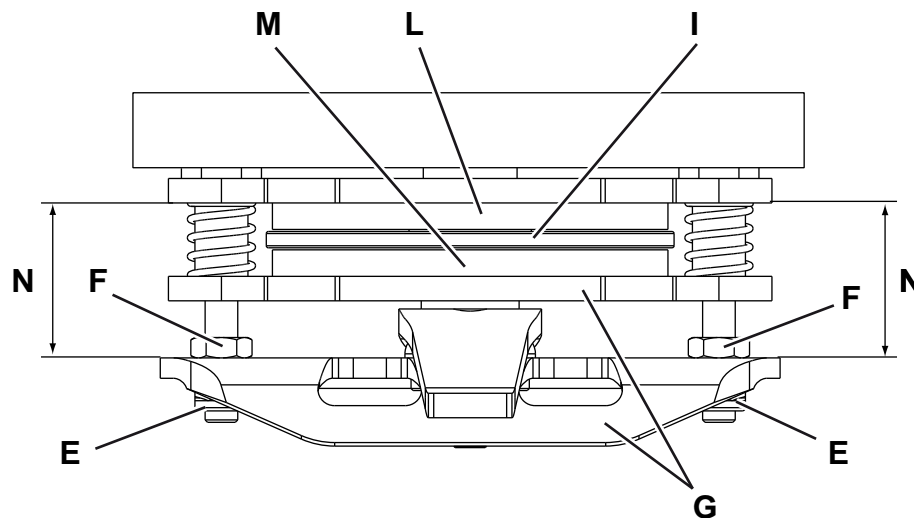
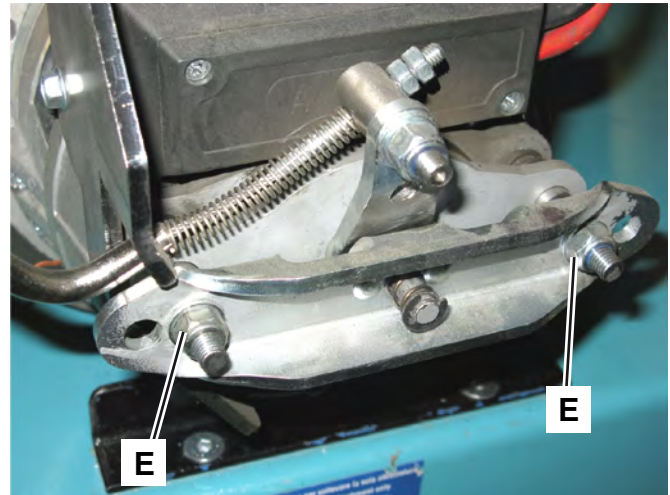
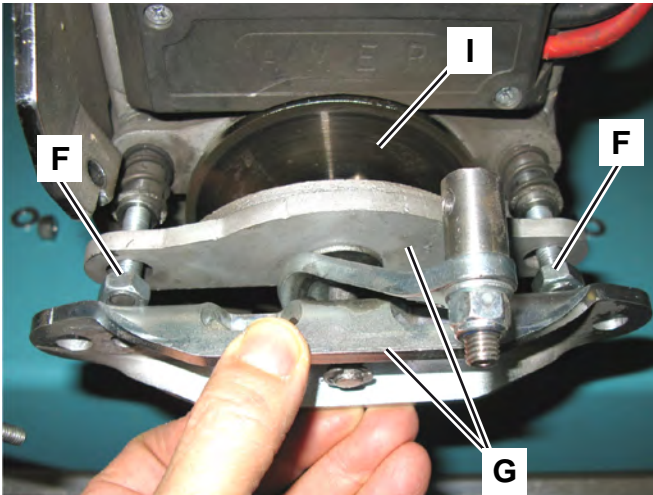

Brake Cable Disassembly/Assembly

Disassembly

1. If possible, place the machine on a hoisting system.
2. Turn the ignition key to “0”. Ensure that the machine cannot move by placing opposite wedges (A) on the rear wheels.
3. Remove the left side broom, if equipped.
4. Steer the front wheel to the right, about 90°.
5. Unscrew nut and locknut (B) then remove the brake cable (C) from the brackets (D).
6. Under the brake pedal, loosen the nut-locknut (H) of the brake cable (C).
7. Remove the clip with the pin (F).
8. Disconnect from the brake pedal the terminal (G) of the cable (C) of the brake.
9. Remove the cable (C) through the slot (L).

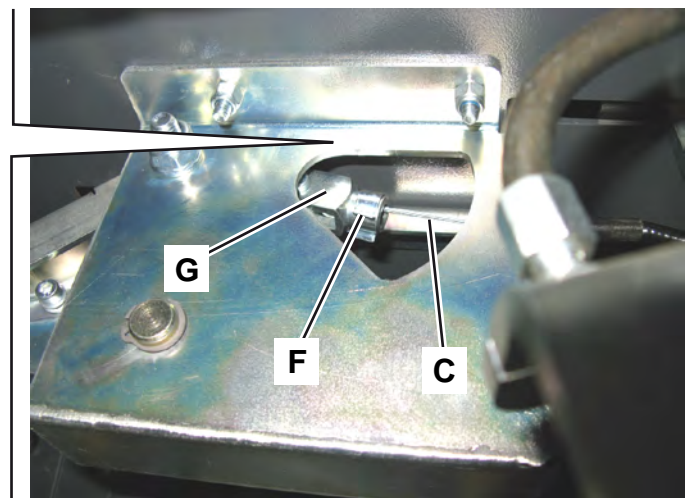
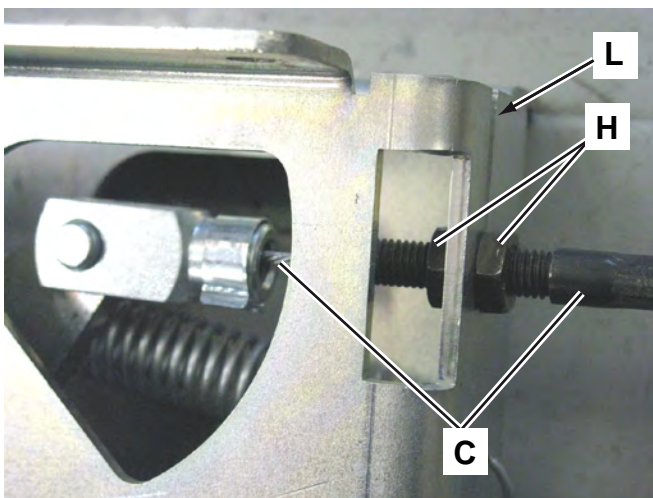
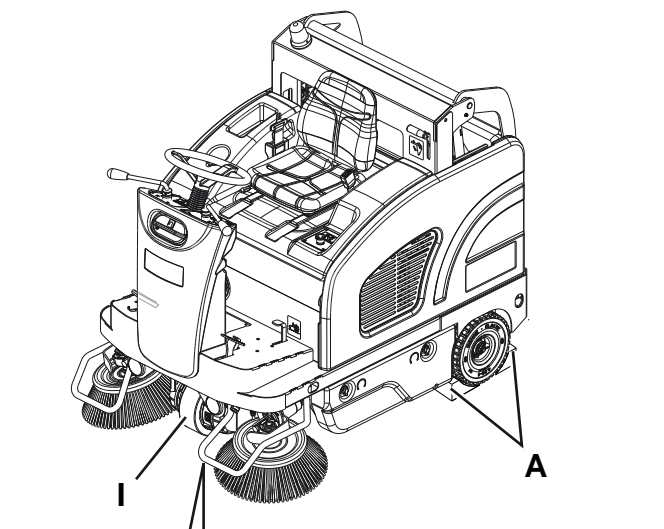
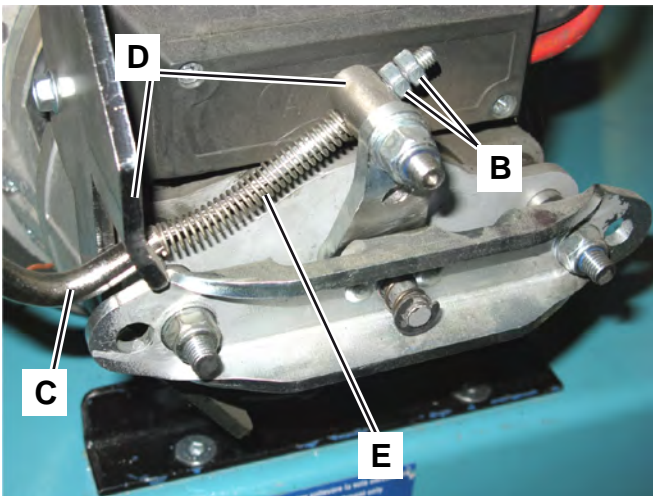

Brake Cable Disassembly/Assembly (Continues)

Assembly

10. Assemble the components in the reverse order of disassembly, and note the following:
 - Adjust the brake according to the following procedure.

Brake Cable Adjustment

1. Ensure that the machine cannot move by placing opposite wedges on the rear wheels.
2. Steer the front wheel to the right, about 90°, so that the brake system becomes accessible.
3. Loosen the locknut (A) and the nut (B).
4. Turn the nut (B) until the distance between the braking masses (C) and the brake disc (D) is 0.5 mm (as shown in the figure).
5. Tighten the locknut (A) with the nut (B).
6. Remove the wedges from the rear wheels.
7. Check the proper adjustment of the brake cable (E) by pushing the machine manually (do not apply the brake).
8. Before starting to operate on the braking masses, check that the stroke of the brake pedal (F) is 1/3 or less of the total stroke (G).
9. Perform brake tests and check the proper operation of the service and parking brake.

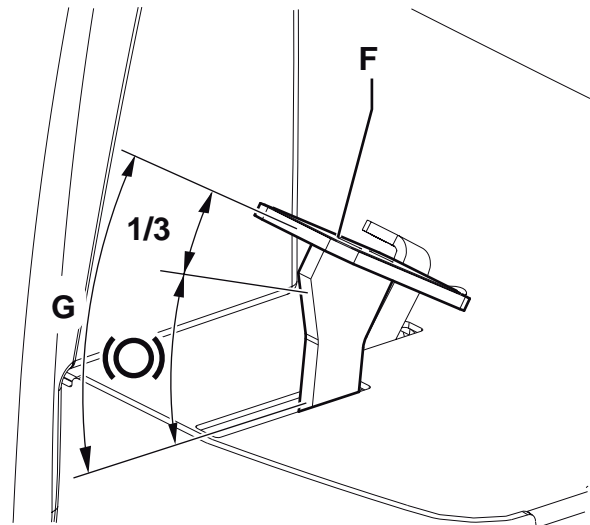
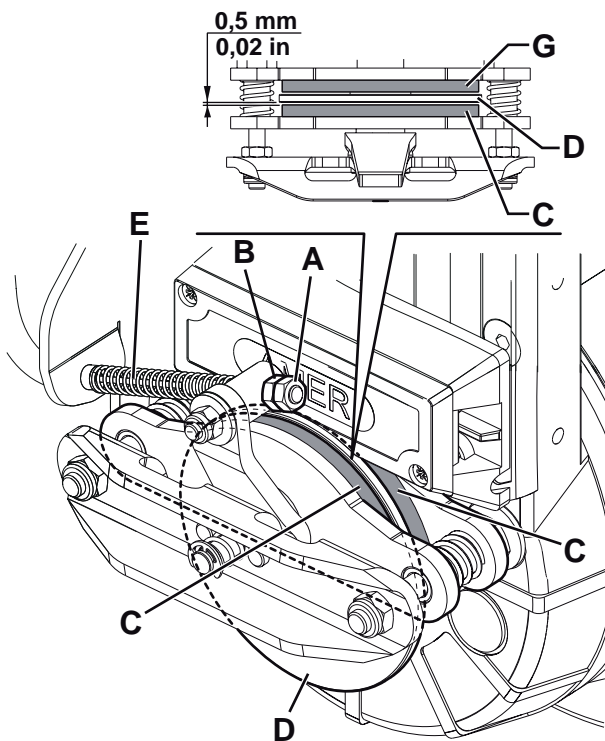

Driving Wheel Amperage Check



Warning! This procedure must be performed by qualified personnel only.

1. Place wedges (A) on the rear wheels of the machine.
2. With a proper hoisting system applied to the machine chassis, to the front wheel area (B), lift the machine a few centimetres, in order to let the front wheel turn freely without touching the floor.
3. Open the battery/engine compartment hood.
4. Apply the amp clamp (C) on the electrical cable (D) of the drive system electronic board (E).
5. Turn the ignition key to “I”.
6. With the help of an assistant, carefully press on the driver’s seat to activate the microswitch, then turn on the drive system at the maximum speed and check that the driving wheel amperage is within 4 and 6 A at 24 V.

Stop the drive system.

Turn the ignition key to “0”.

Remove the amp clamps (C).

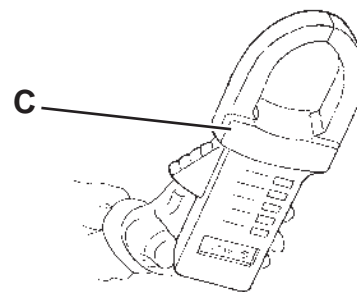
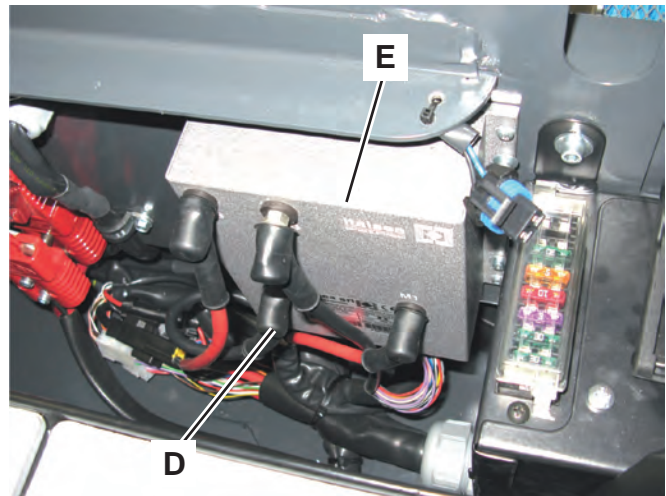
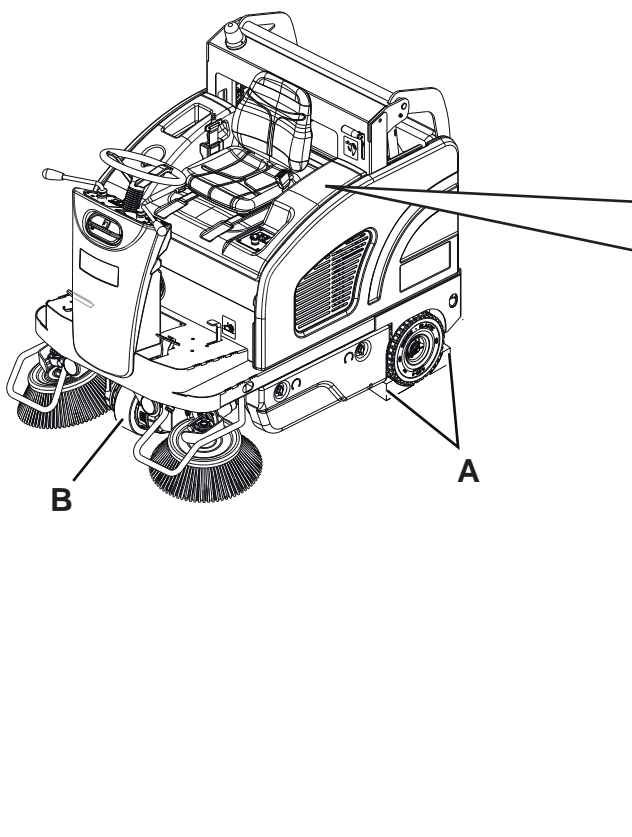

Driving Wheel Amperage Check (Continues)

If the amperage is higher, perform the following procedures to detect and correct it:

- Check that there is no dust or debris (ropes, cables, etc.) on the driving wheel, that can prevent it from turning.
- Check the carbon brushes of the drive system motor (see the procedure in the relevant paragraph)
- If necessary, disassemble the drive system motor (see the procedure in Driving Wheel and Steering Unit Disassembly/Assembly paragraph), and check the condition of all its components.

If the above-mentioned procedures do not lead to correct readings for the driving wheel amperage, the driving wheel must be replaced (see the procedure in Driving Wheel and Steering Unit Disassembly/Assembly paragraph).

Reassembly

7. Close the battery/engine compartment hood.
8. Remove the front hoisting system of the machine.
9. Remove the wedges from the rear wheels.

Drive System Motor Carbon Brush Check/Replacement

Disassembly

1. Drive the machine on a level floor.
2. Turn the ignition key to “0” and engage the parking brake.
3. Open the battery/engine compartment hood.

Disconnect the battery connector (SW4000 Battery) - Disconnect the batteries (SW4000 Petrol/LPG).

4. Remove in sequence each of the four carbon brushes of the drive system motor, as shown below:
 - Remove the cover (A) (bayonet joint).
 - Remove the O-ring (B).
 - Loosen the screws (C).
 - Remove the carbon brush with the spring (D).

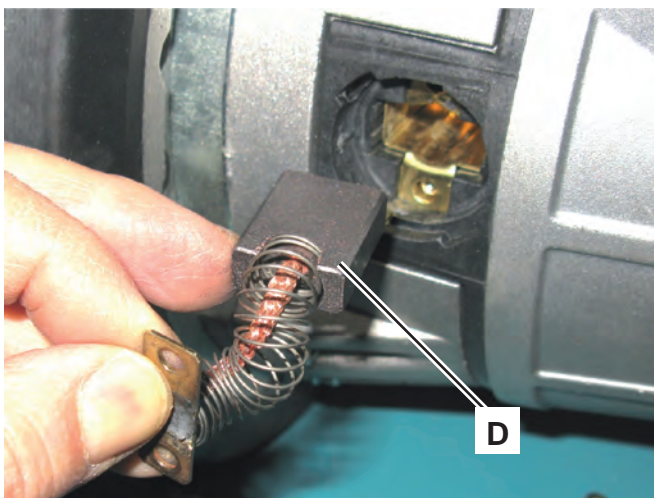
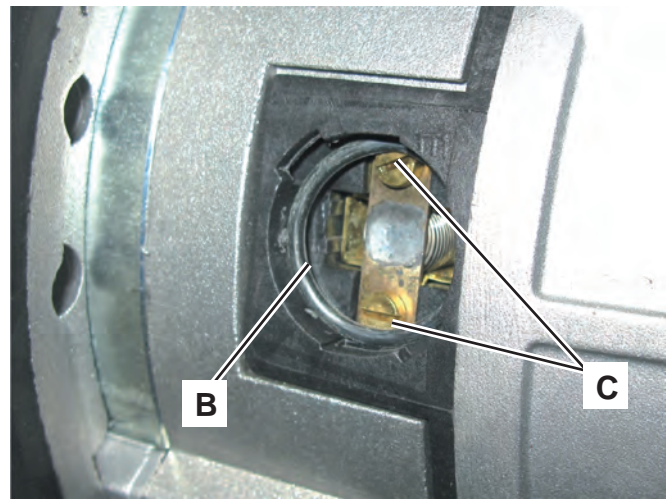
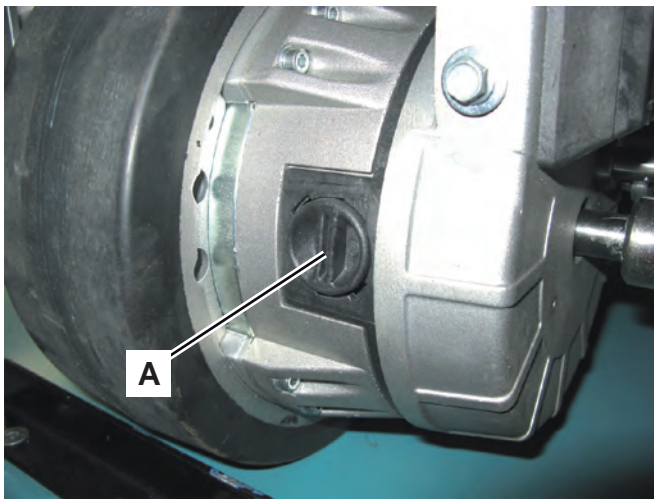

Drive System Motor Carbon Brush Check/Replacement (Continues)

5. Check the four carbon brushes (D) for wear. The carbon brushes are worn when:
 - The contact with the motor armature is insufficient
 - The contact surface is not integral
 - The stroke is less than 0.47 in (12 mm)
 - The spring is broken
6. Remove the two lateral carbon brushes of the drive motor, as shown below:
 - Loosen the two screws (E)
 - Remove the lateral cover (F)
 - Loosen the screws (G)
 - Remove the carbon brushes with the spring (H)
7. Check the two carbon brushes (H) for wear. The carbon brushes are worn when:
 - The contact with the motor armature is insufficient
 - The contact surface is not integral
 - The stroke is less than 0.47 in (12 mm)
 - The spring is broken

In this cases, replace all the six motor carbon brushes.

Assembly

8. Assemble the components in the reverse order of disassembly.

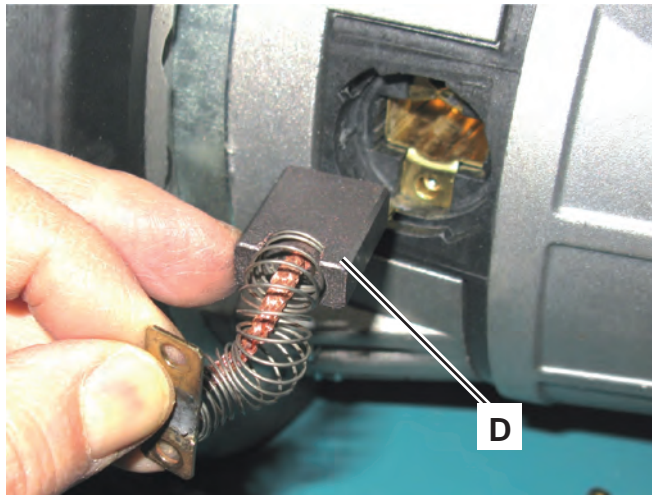

P200243

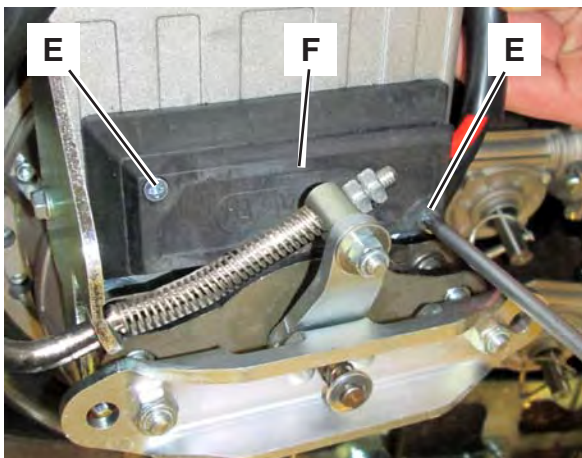

P200243A

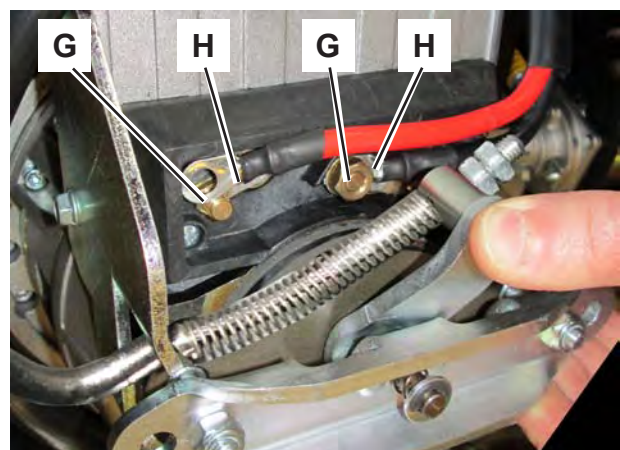

P200243B

Front Wheel Rubber Ring Disassembly/Assembly

Disassembly

1. If possible, place the machine on a hoisting system.
2. Turn the ignition key to “0”. Ensure that the machine cannot move by placing opposite wedges (A) on the rear wheels.
3. With a proper hoisting system applied to the machine chassis, to the front wheel area (B), lift the machine a few centimetres, in order to reach the rubber ring and remove it.
4. Steer the front wheel to the right, about 90°.
5. Unscrew nut and locknut (C) then remove the brake cable (D) from the brackets (E). Retrieve the spring (F).

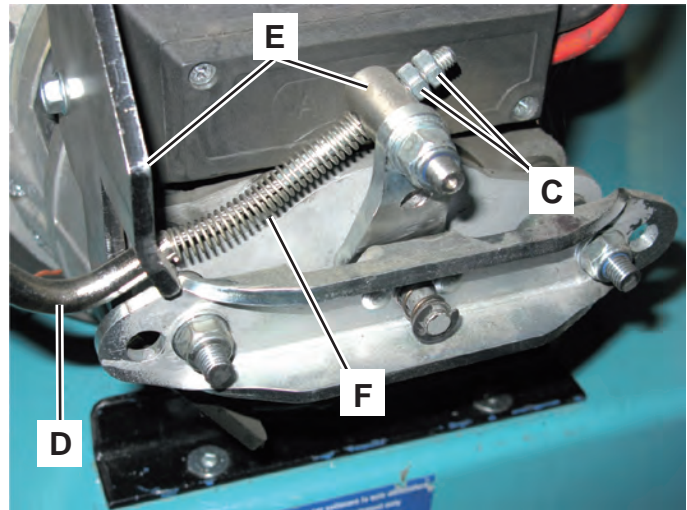
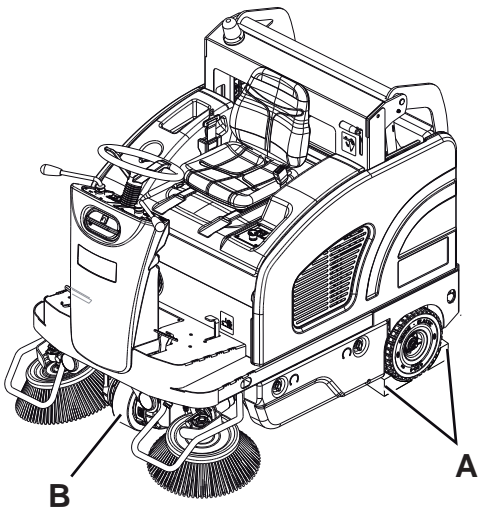

P200203

Front Wheel Rubber Ring Disassembly/Assembly (Continues)

6. Remove the screws (G) on the left side of the front wheel assembly.
7. Remove the spacer (H).
8. Remove the left bracket (I); if necessary use a puller (J).
9. Unscrew the nuts (K) and remove the fastening screws (L) of the rubber ring (N). Retrieve the washers (M).
10. Remove the rubber ring (N) from the reduction unit (P).

Assembly

11. Assemble the components in the reverse order of disassembly, and note the following:
 - To ease the installation of the rubber ring (N) on the reduction unit (P), slightly hit the side edge of the rubber ring with a plastic mallet in a criss-cross pattern.
 - Tighten the rubber ring fastening nuts (K) at 16 Nm.
 - Tighten the left bracket fastening screws (G) at 22 Nm.
12. Adjust the brake as described in the procedure for brake cable disassembly/assembly.

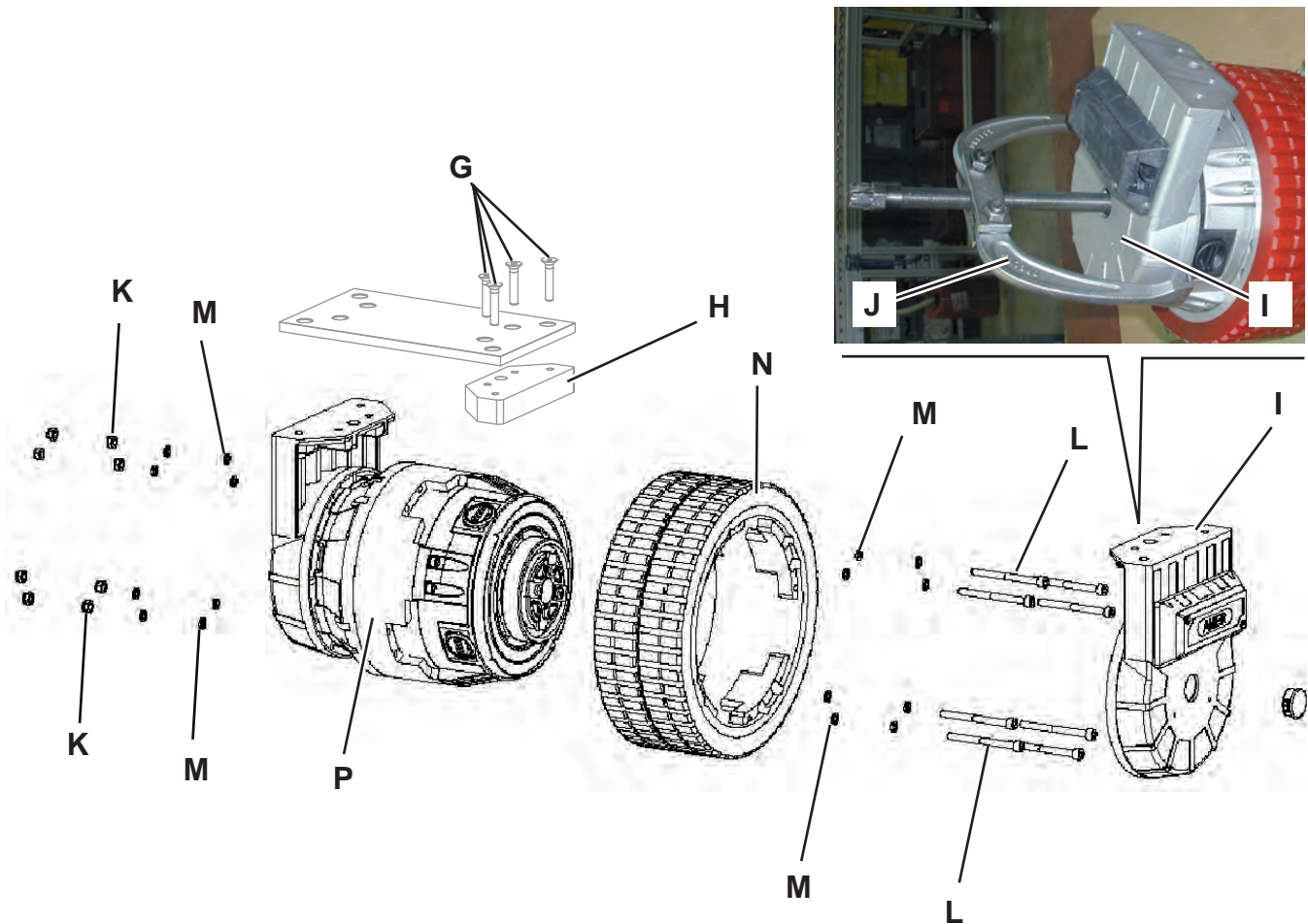

Driving Wheel and Steering Unit Disassembly/Assembly

Disassembly

1. If possible, place the machine on a hoisting system.
2. Turn the ignition key to “0”. Ensure that the machine cannot move by placing opposite wedges (A) on the rear wheels.
3. Open the battery/engine compartment hood.
Disconnect the battery connector (SW4000 Battery) - Disconnect the batteries (SW4000 Petrol/LPG).
4. With a proper hoisting system applied to the machine chassis, to the front wheel area (B), lift the machine a few centimetres, in order to easily remove the driving wheel assembly.
5. Remove the fastening screws (C) of the fairing (D) from the steering column.
6. Slightly lift the steering column fairing (D) by disengaging it from the lower fastener (E).
7. Disconnect the dust guard system quick coupling (F).
8. Retrieve the fairing (D).

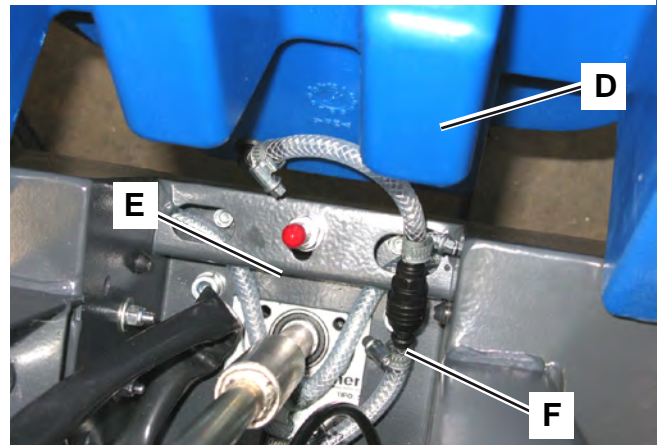
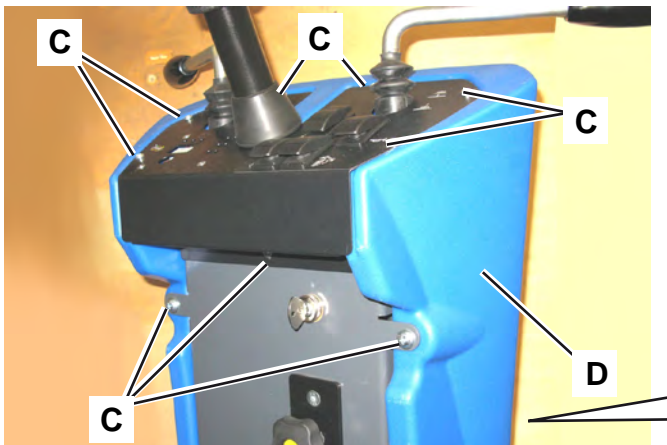
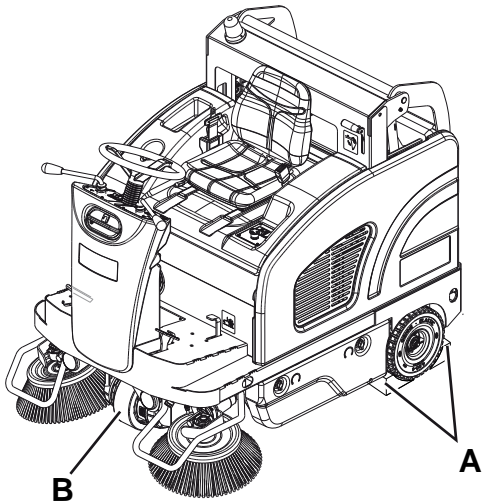

Driving Wheel and Steering Unit Disassembly/Assembly (Continues)

9. Steer the front wheel to the right, about 90°.
10. Unscrew nut and locknut (G) then remove the brake cable (H) from the brackets (I). Retrieve the spring (J).
11. Remove the screws (L) and the cover (M).
12. Remove the nuts and disconnect the electrical connections (N) from the driving wheel.
13. Disconnect the brake cable (P) from the clamps (Q).

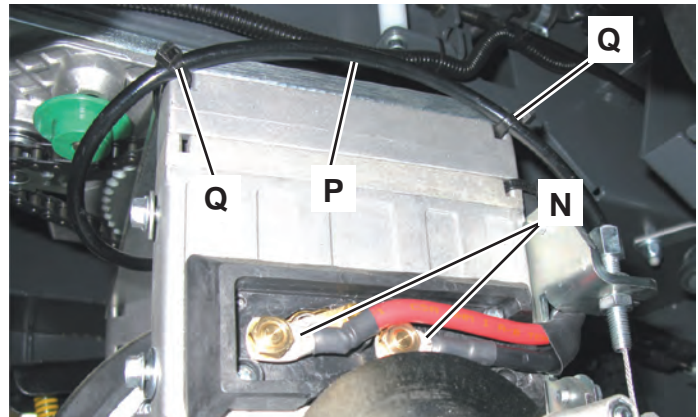
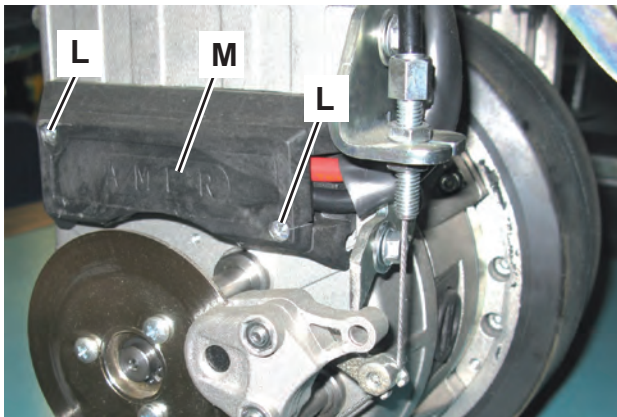
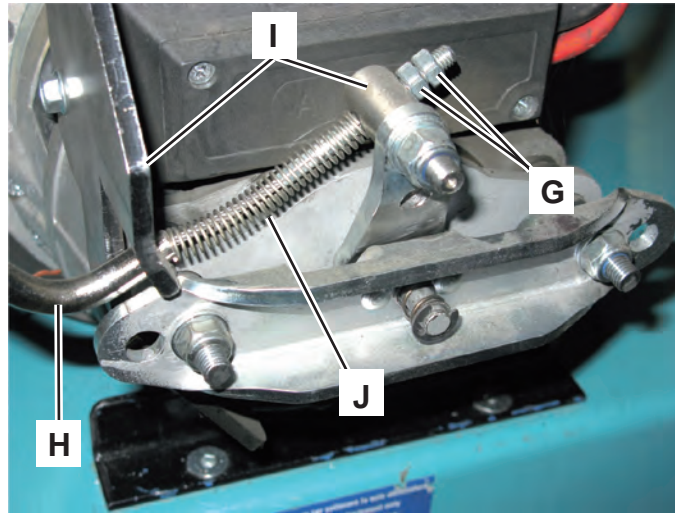

Driving Wheel and Steering Unit Disassembly/Assembly (Continues)

14. At the base of the steering column (R) remove the screws (S) and remove the cover (T).
15. Remove the four fastening screws (U) of the driving wheel assembly (V).
16. Remove from the machine the driving wheel assembly (V) with the steering assembly (W), by removing the hub (X) from the steering shaft; retrieve the key (Y).
17. If necessary, remove the screws (Z) and then separate the driving wheel assembly (V) from the steering wheel assembly (W).

Assembly

18. Assemble the components in the reverse order of disassembly.
19. Adjust the brake as described in the procedure for brake cable disassembly/assembly.

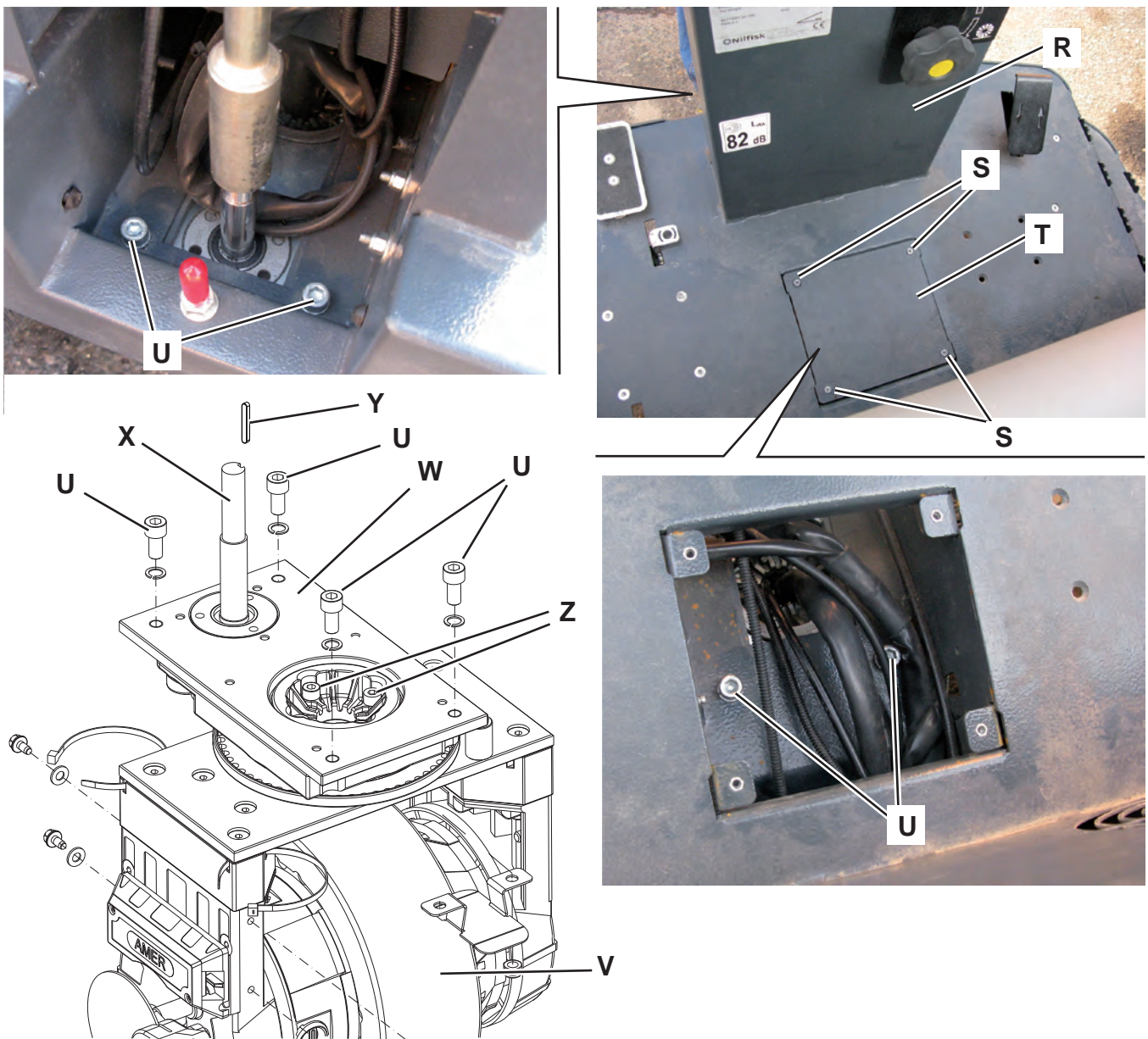

Front Driving Wheel Armature Disassembly/Assembly

Disassembly

1. Remove the driving wheel and steering assembly (see the procedure in the previous paragraph).
2. Workbench, remove the screws (A) on the left side of the front wheel assembly.
3. Remove the spacer (B).
4. Remove the left bracket (C); if necessary use a puller (D).
5. With a marker, draw an alignment sign (E) between the rubber ring (F) and the carbon brush cap (G), for a proper reassembly (to avoid that the driving wheel turns in the wrong direction).

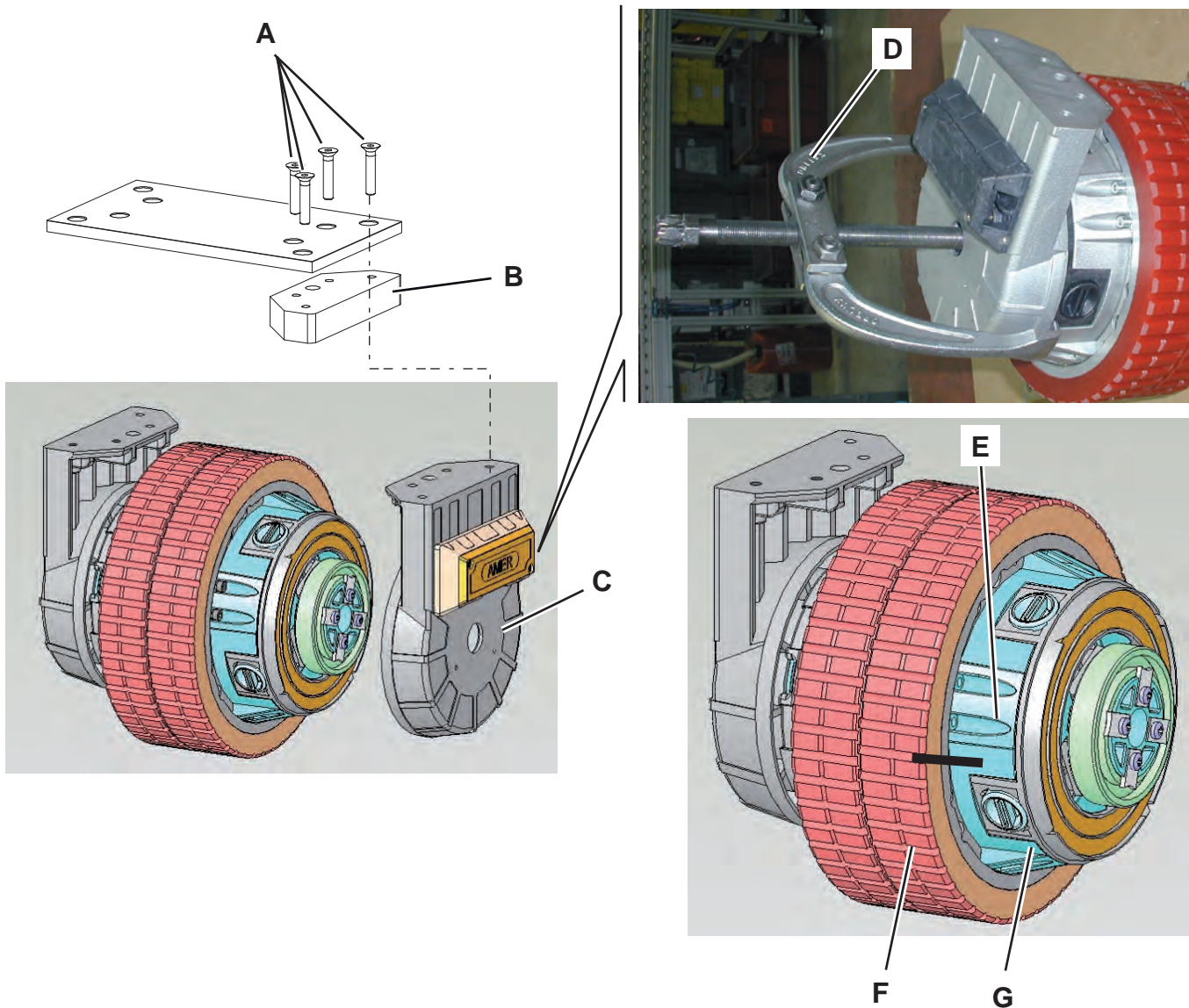

Front Driving Wheel Armature Disassembly/Assembly (Continues)

6. Remove the fastening screws (H) of the carbon brush cap (J). Retrieve the washers (I).
7. Remove the carbon brush cap assembly (J); take the greatest care in order not to remove/displace the stator from its position.
8. Remove the compensating ring (K).
9. Place the assembly (L) with the outer side (M) of the right bracket laying horizontally on the workbench, in order to prevent the oil from spilling out when removing the armature (N).
10. Remove the armature (N) taking care not to damage the reduction unit oil grommet (P).

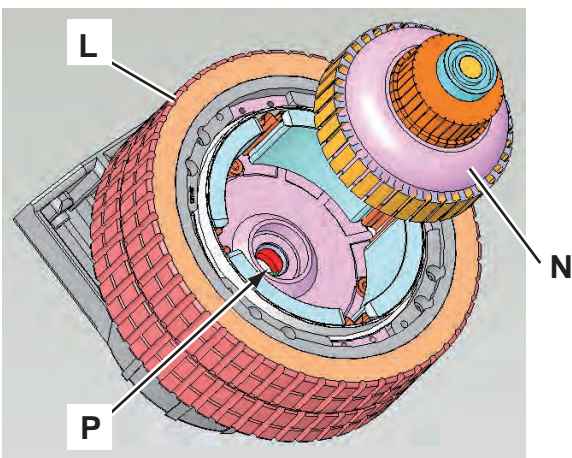
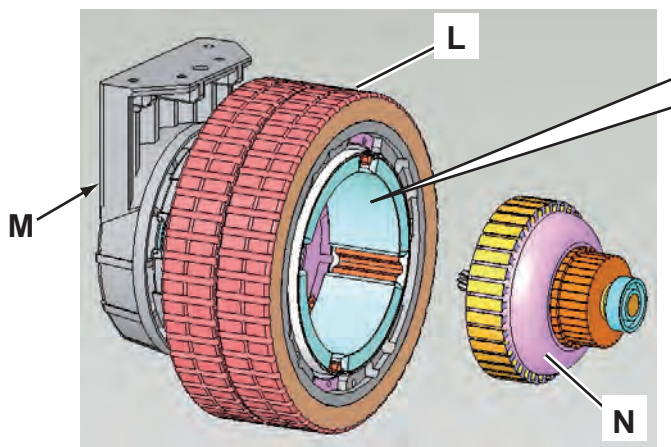
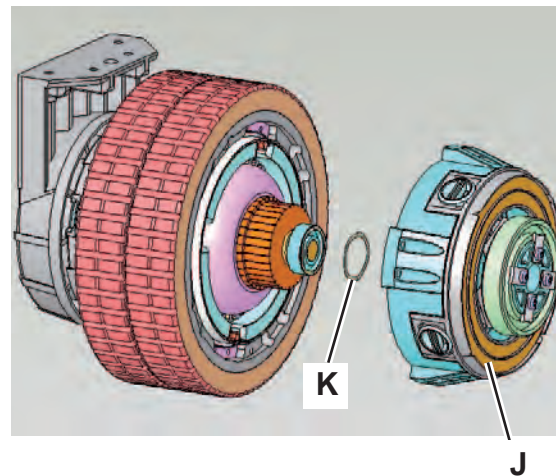
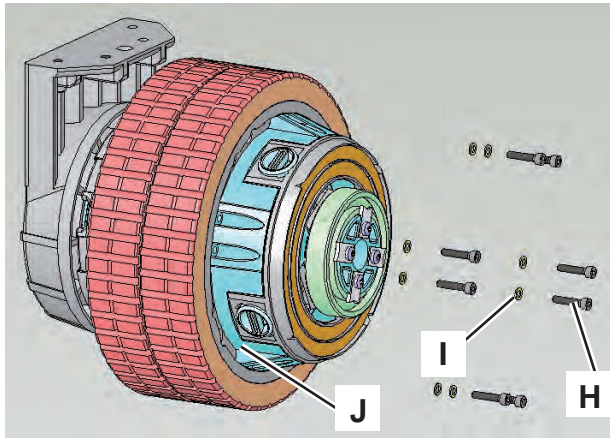

Front Driving Wheel Armature Disassembly/Assembly (Continues)

Assembly

11. Assemble the components in the reverse order of disassembly, and note the following:
 - Remove any dust or debris from the stator and removed components.
 - Lubricate with grease the grommet lips (P) before reassembling the armature (N).
 - Check that the bearings of the armature (N) are properly installed on the shaft.
 - To ease the installation of the carbon brush cap assembly (J) unscrew the caps and temporarily remove the carbon brushes (refer to the procedure “Drive System Motor Carbon Brush Check/Replacement” in the relevant paragraph).
 - Assemble the carbon brush cap assembly (J) with the reference mark (E) matching the position marked during the removal procedure.
 - Tighten the fastening screws (H) of the carbon brush cap (J) at 5.5 Nm.
 - Tighten the fastening screws (A) of the left bracket (C) at 22 Nm.
12. Check the proper operation of the driving wheel.
13. Reassemble the driving wheel and steering assembly (see the procedure in the previous paragraph).

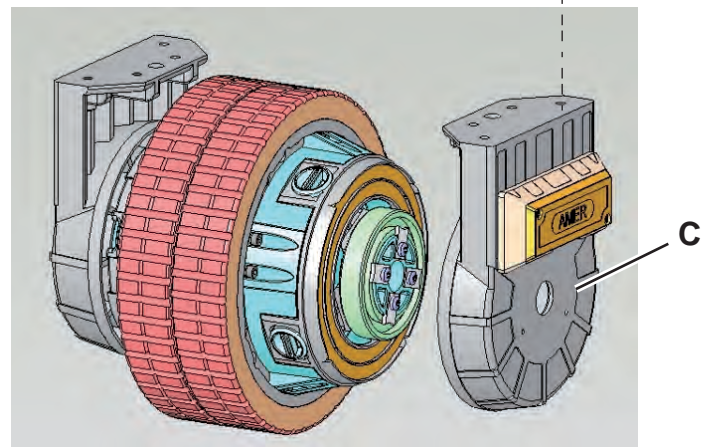
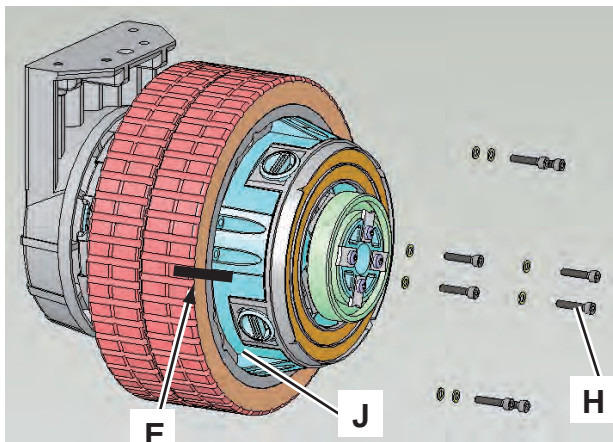
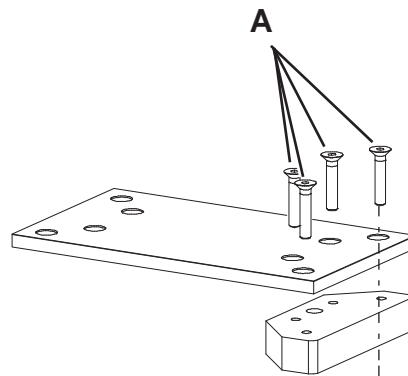
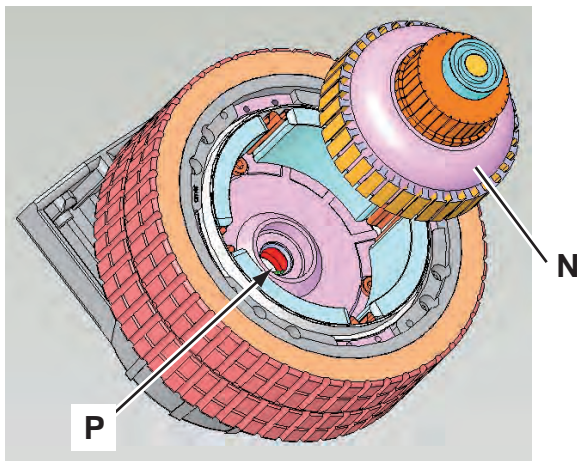

Accelerator Pedal Disassembly/Assembly

Disassembly

1. If possible, place the machine on a hoisting system.
2. Loosen the screw (B) under the accelerator pedal (A).
3. Remove the accelerator pedal (A) from the shaft (C).
4. Remove the three fastening screws (D) of the accelerator pedal control (E).
5. Disconnect the accelerator pedal control connector (F).
6. Disengage the electrical cable (G) from the retaining clamps (H).
7. Retrieve the accelerator pedal control (E) with the wiring harness.

Assembly

8. Assemble the components in the reverse order of disassembly, and note the following:
 - Fasten the accelerator pedal (A) on the shaft (C) with the screw (B) under the following condition:
 - with the accelerator pedal at the front end of stroke, the surface (I) must be aligned with the surface (J).

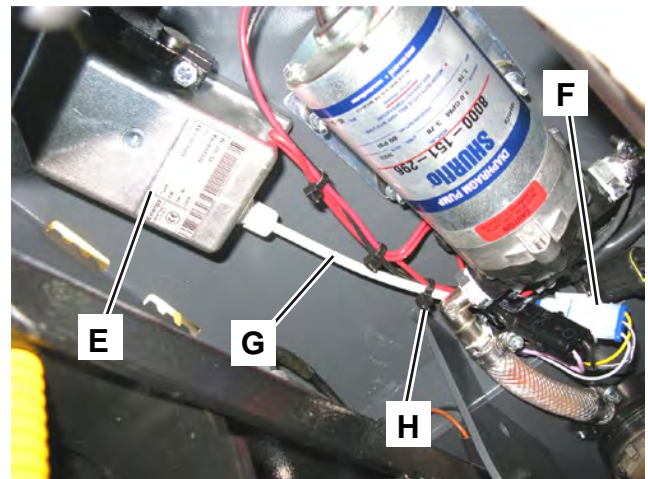
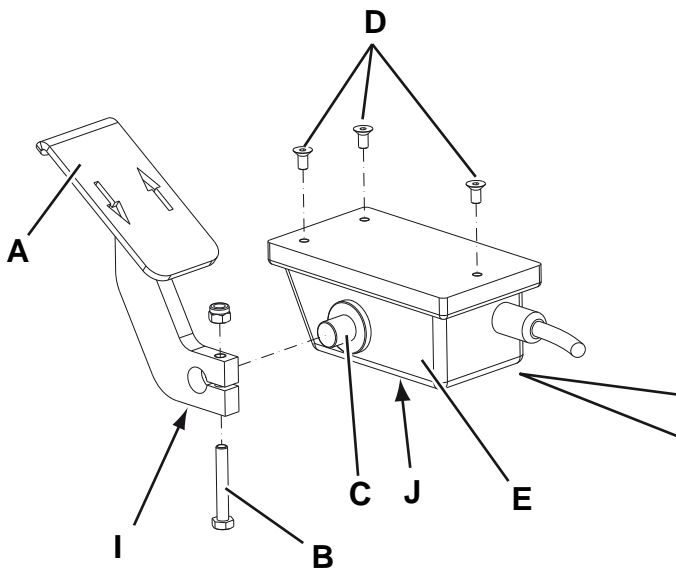

Drive System Electronic Board Disassembly/Assembly

Disassembly

1. Drive the machine on a level floor.
2. Turn the ignition key to “0” and engage the parking brake.
3. Open the battery/engine compartment hood.

Disconnect the battery connector (SW4000 Battery) - Disconnect the batteries (SW4000 Petrol/LPG).

4. On the left rear side of the battery/engine compartment, disengage the protection caps (A) and disconnect the electrical connections of the drive system electronic board (B).
5. Remove the four side socket head screws (C) fastening the drive system electronic board (B).
6. Slightly lift the drive system electronic board (B) and disconnect its connector (D), then retrieve it.

Assembly

7. Assemble the components in the reverse order of disassembly.

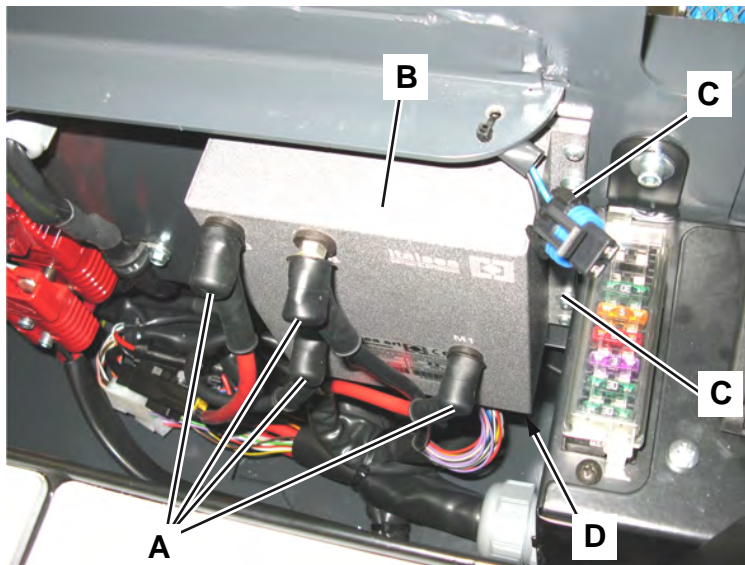

Driver's Seat Microswitch Disassembly/Assembly

Disassembly

1. Drive the machine on a level floor.
2. Turn the ignition key to "0" and engage the parking brake.
3. Open the battery/engine compartment hood.

Disconnect the battery connector (SW4000 Battery) - Disconnect the batteries (SW4000 Petrol/LPG).

4. On the lower side of the battery/engine compartment (A), remove the driver's seat microswitch connector (B) from its housing and disconnect it.
5. Close the hood (A).
6. Move the seat (C) forward and remove it from the rails (D).
7. Retrieve the seat (C) with the wiring harness (E).
8. If necessary, remove the screws (F) and remove the seat rails (D).

Assembly

9. Assemble the components in the reverse order of disassembly, and note the following:
 - Before tightening the screws (F) check that the seat rails (D) are aligned.
 - After the seat have been reinstalled, check that it slides properly on the rails, and also check that it engages properly in each position.

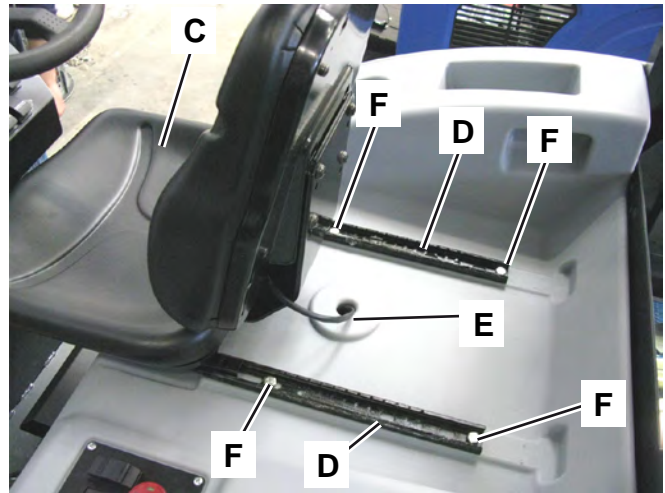
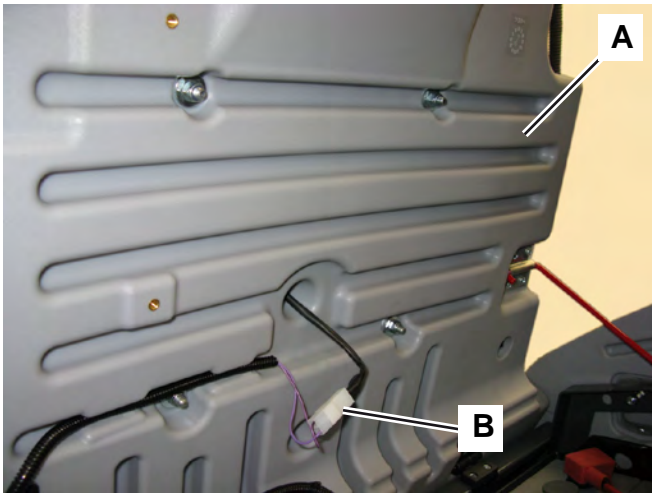

Specifications

Wheel System Traction	Values		
	SW4000 Battery	SW4000 Petrol	SW4000 LPG
U-turn space (right - left)	75.6 - 74.4 in (1,920 - 1,890 mm)		
Forward speed	4.3 mi/h (7 km/h)		
Maximum reverse speed	2.8 mi/h (4.5 km/h)		
Gradeability	20%		
Front wheel specific pressure on the floor	131 psi (0.9 N/mm ²)		
Front driving and steering wheel (diameter x width)	9.8 x 3.5 in (250 x 90 mm)		
Drive system motor	1.35 hp (1,000 W) - 315 rpm		