

Granterra

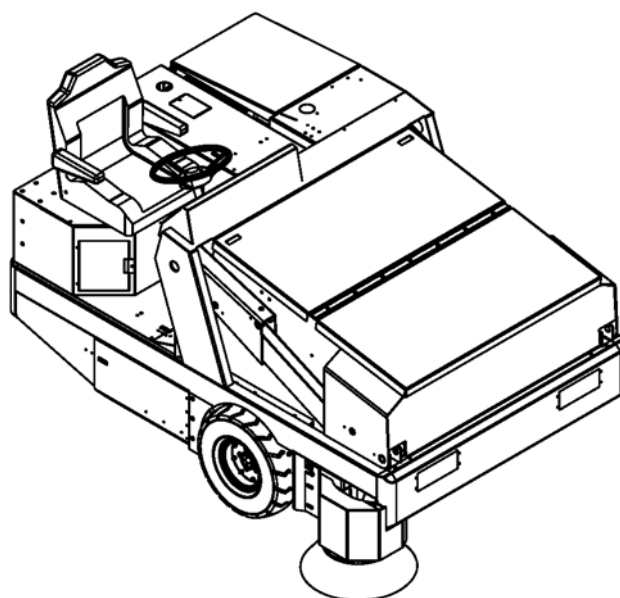

PARTS LIST

Models 56516904(Gas), 56516905(LPG), 56516906(Diesel)

DESCRIPTION	PAGE
Frame, Broom Doors, & Flaps	4-5
Main Broom Assembly	6-7
Main Broom Lift Mechanism.....	8-9
Side Broom Assembly.....	10-11
Operator Compartment	12-13
Control Panel & Horn	14-15
Hopper System - 1	16
Hopper System - 2	17
Hopper System - 3	18-19
Hopper Lift System.....	20-21
Steering Gear & Rear Drive System	22-23
Forward/Reverse Assembly (Gasoline/LPG/Diesel)	24-25
Forward/Reverse Control (Gasoline & LPG Only)	26-29
Forward/Reverse Control (Diesel Only)	30-31
Front Wheel & Brake Assembly	32-33
Brake Control Linkage.....	34-35
Impeller & Fittings	36-37
Control Valve & Fittings.....	38-39
Main Broom Motor & Fittings.....	40-41
Side Broom Motor & Fittings	42
Lift, Rotation & Dump Cylinders w/ Fittings.....	43
Lift Cylinder Lock-out Valve & Fittings.....	44
Auxiliary Manifold & Fittings	45
Return Manifold Assembly	46-47
Hydraulic Reservoir & Fittings.....	48-49
Engine Cover	50-51
Engine Access Door.....	52-53
GM 3.0 Liter - Gas & LP Engines (Mounting Brackets) IMPCO	54-55
GM 3.0 Liter - Gas & LP Engines (Mounting Brackets) PSI.....	56-57
GM 3.0 Liter - Gas Engine (Fan, Air Intake & Radiator Hoses).....	58-59
GM 3.0 Liter - LP Engine (Fan, Air Intake Radiator Hoses) IMPCO	60-61
GM 3.0 Liter - LP Engine (Fan, Air Intake Radiator Hoses) PSI	62-63
GM 3.0 Liter - Gas & LP Engines (Exhaust System)	64-65
GM 3.0 Liter - Gas Engine (Fuel System).....	66-69
Radiator Assembly - GM 3.0 Liter Engine (Gasoline & LPG).....	70-71
LP Tank System	72-73
Air Cleaner Assembly (Gasoline/LPG/Diesel).....	74-75
Mitsubishi S4Q2 Tier 4 - Diesel Engine (Fan, Brackets, Throttle).....	76-77
Mitsubishi S4Q2 Tier 4 - Diesel Engine (Exhaust System)	78-79
Mitsubishi S4Q2 Tier 4 - Diesel Engine (Fuel System)	80-81
Radiator Assembly (Diesel).....	82-83
Fuel Tank (Diesel)	84-85
Decals	86-87
Instrument Panel.....	88-89
Hydraulic Hose System.....	90-93
Harness Routing (Gasoline/LPG/Diesel).....	94-95
Wiring Diagram	96
Broom Selector Guide.....	97

WHEN ORDERING PARTS

- * Use the part numbers from the "Ref. No." columns in this parts list.
- * Specify the model and serial number of the machine.
- * Use the space below to record the model and serial number for future reference.

Model _____ Serial No. _____

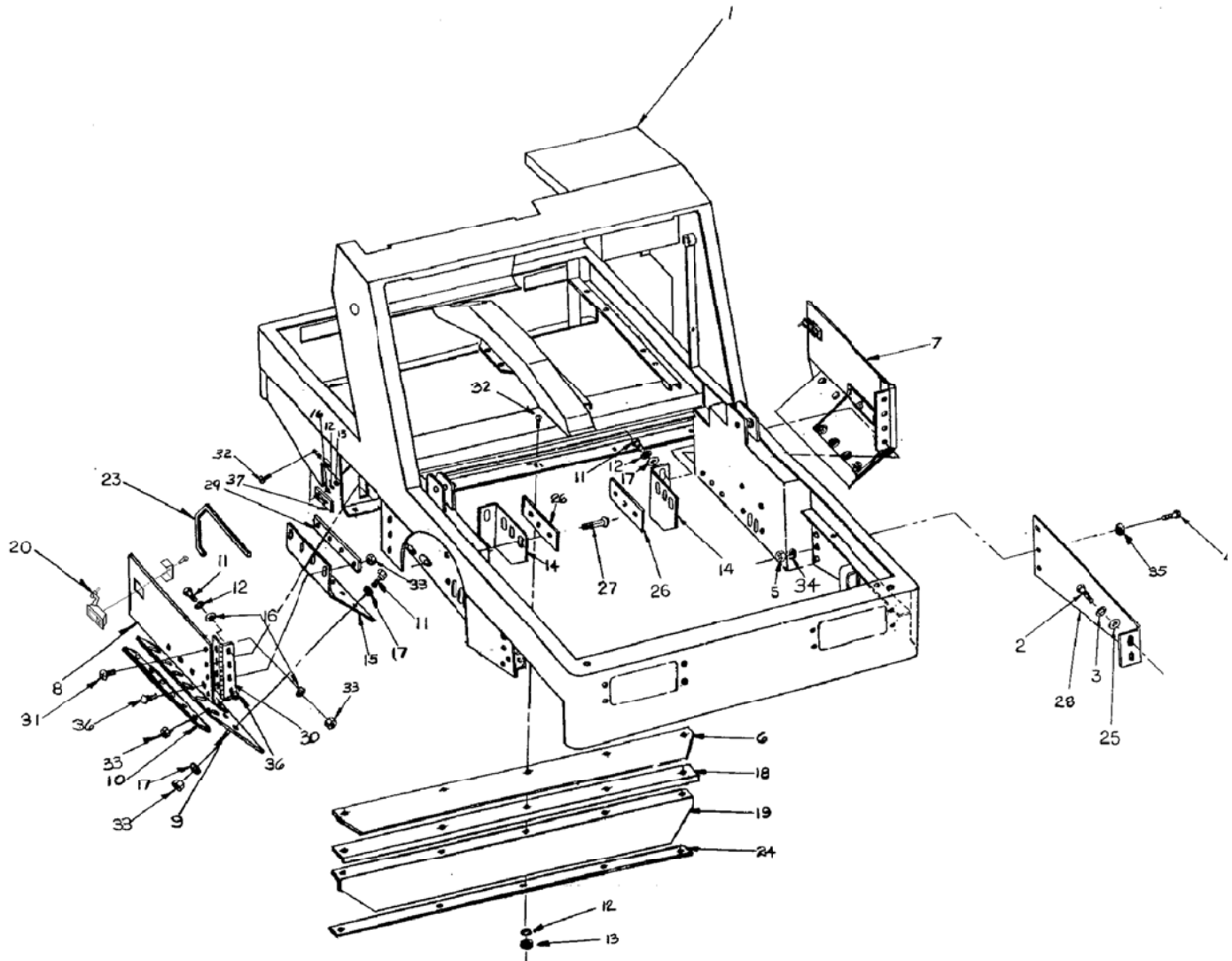

Item	Ref. No.	Qty	Description
1	56516778	1	Frame
2	2-00-00233	2	Screw, 3/8-16 x 1.0 HHC
3	2-00-02310	2	Lock Washer, 3/8 Helical Spring
4	2-00-00240	3	Screw, 1/2-13 x 1.25 HHC
5	2-00-00596	3	Nut, 1/2-13 x .750 x .437 Hex
6	8-25-08172	1	Flap, Rear Inside BC Frame
7	56516779	1	Door, LH Broom Chamber
8	56516780	1	Door, RH Broom Chamber
9	8-25-08185	2	Flap, Outer BC Door
10	56516781	2	Clamp, Outer BC Door Flap
11	2-00-00205	16	Screw, 1/4-20 x 3/4 HHC
12	2-00-00518	17	Lock Washer, 1/4 Helical Spring
13	2-00-00594	5	Nut, 1/4-20 x .437 x .218 Hex
14	8-25-08174	2	Flap, Wheel Well
15	8-25-08184	2	Flap, Inner Broom Door
16	2-00-03702	18	Flat Washer, .625 x .281 x .062
17	2-00-01676	18	Flat Washer, 1.062 x .265 x .062
18	56516782	1	Clamp, BC Inner Rear Flap
19	8-25-08173	1	Flap, Rear Outside BC Frame
20	7-41-00065	2	Latch, Broom Door
23	8-68-05073	2	Seal, Main Broom Chamber
24	56516783	1	Clamp, Outer BC Rear Flap
25	2-00-00402	2	Flat Washer, .750 x .390 x .093
26	56516784	2	Clamp, Wheel Well Flap
27	2-00-04877	6	Screw, 1/4-20 x 1.0
28	56516785	1	Front Skirt
29	56516786	2	Clamp, Inner Broom Door Flap
30	8-32-00043	2	Hinge, Plated
31	2-00-00078	8	Screw, 1/4-20 x 1.0 HHC
32	2-00-02196	9	Carriage Bolt, 1/4-20 x 1.0
33	2-00-00641	36	Nut, 1/4-20 Fiber Lock
34	2-00-02312	3	Lock Washer, 1/2 Helical Spring
35	2-00-04159	3	Flat Washer, 9/16 I.D.
36	2-00-03575	18	Carriage Bolt, 1/4-20 x 3/4
37	8-41-00047	2	Tab, Broom Door Latch

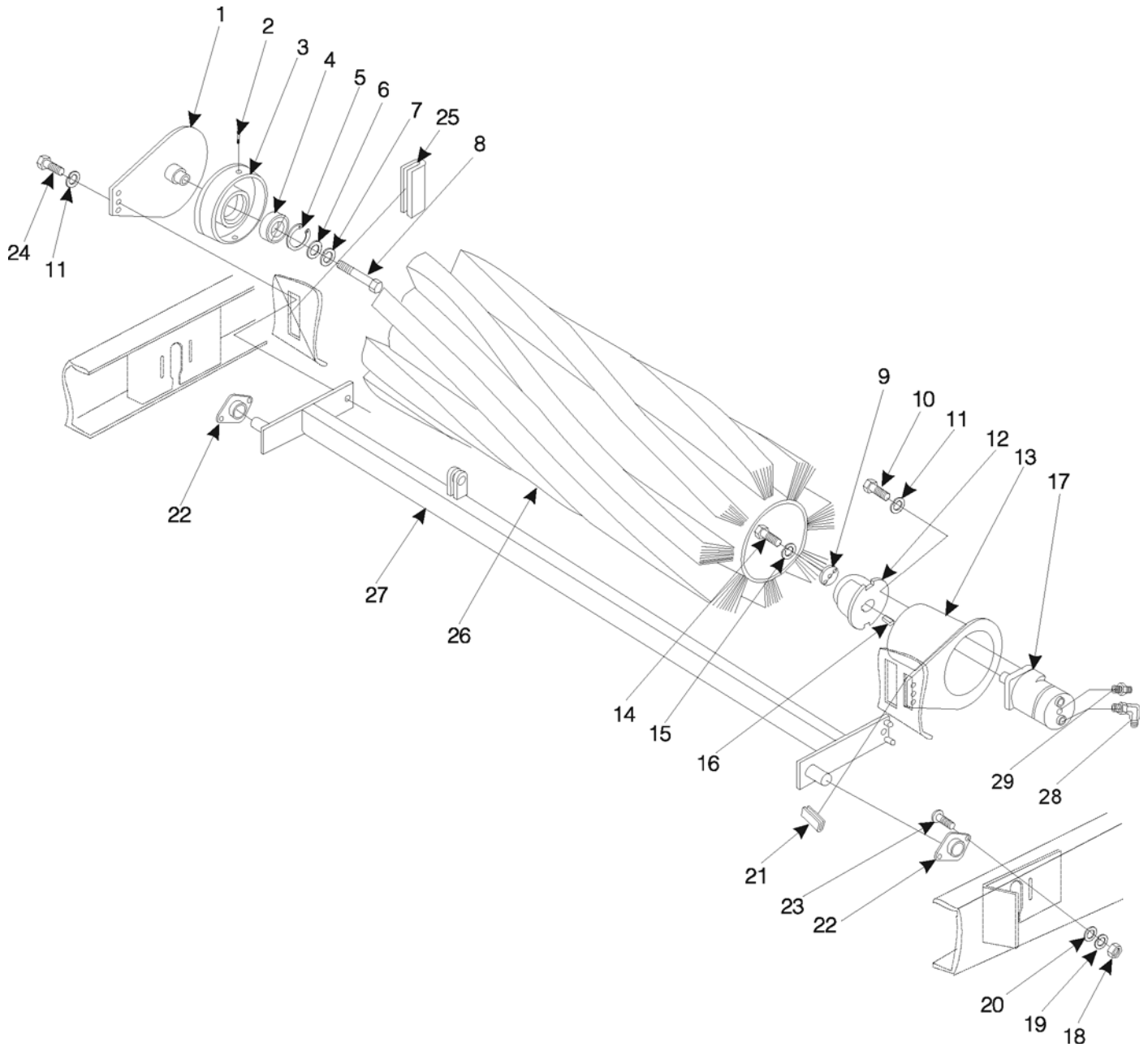

Item	Ref. No.	Qty	Description
1	8-16-00039	1	Broom Arm Weldment
2	2-00-04886	2	Screw, 3/8-16 x 1/2 HSHC
3	8-33-09090	1	Idle, Main Broom
4	2-00-04889	1	Ball Bearing
5	2-00-04890	1	Retaining Ring, 2.437 Int.
6	8-75-01157	1	Flat Washer, 3/4
7	2-00-00522	1	Lock Washer, 3/4 Helical Spring
8	2-00-04887	1	Screw, 3/4-10 x 1.25 HHC
9	8-58-05160	1	Plate, Locking Hub
10	2-00-00232	4	Screw, 3/8-16 x 3/4 HHC
11	2-00-02310	6	Lock Washer, 3/8 Helical Spring
12	8-33-09046-1	1	Drive Hub
13	8-16-00041	1	Arm, Drive Broom
14	2-00-03039	3	Screw, 1/4-20 x .625 HSHC
15	2-00-00518	6	Lock Washer, 1/4 Helical Spring
16	2-00-00722	1	Woodruff Key, 1/4 x 1 (#15)
17	0882-040	1	Hydraulic Motor
18	2-00-00585	4	Nut, Hex 5/16-18 x .500 x .265
19	2-00-00530	4	Lock Washer, 5/16 Helical Spring
20	2-00-00409	4	Flat Washer, .687 x .343 x .062
21	8-21-04048	2	Edging
22	2-00-03997	2	Flange Bearing, 3.750 x 1.0
23	2-00-00196	4	Carriage Bolt, 5/16-18 x 1.0
24	2-00-00233	2	Screw, 3/8-16 x 1.0 HHC
25	8-29-00220	4	Gasket, Broom Chamber
26	REF	1	Main Broom (see Broom Selector Guide)
27	8-03-04281	1	Lift Frame, Main Broom
28	2-00-04885	1	Elbow Fitting - 90° St. Thd.
29	2-00-04895	1	Straight Fitting - SAE #4 to ORS #4

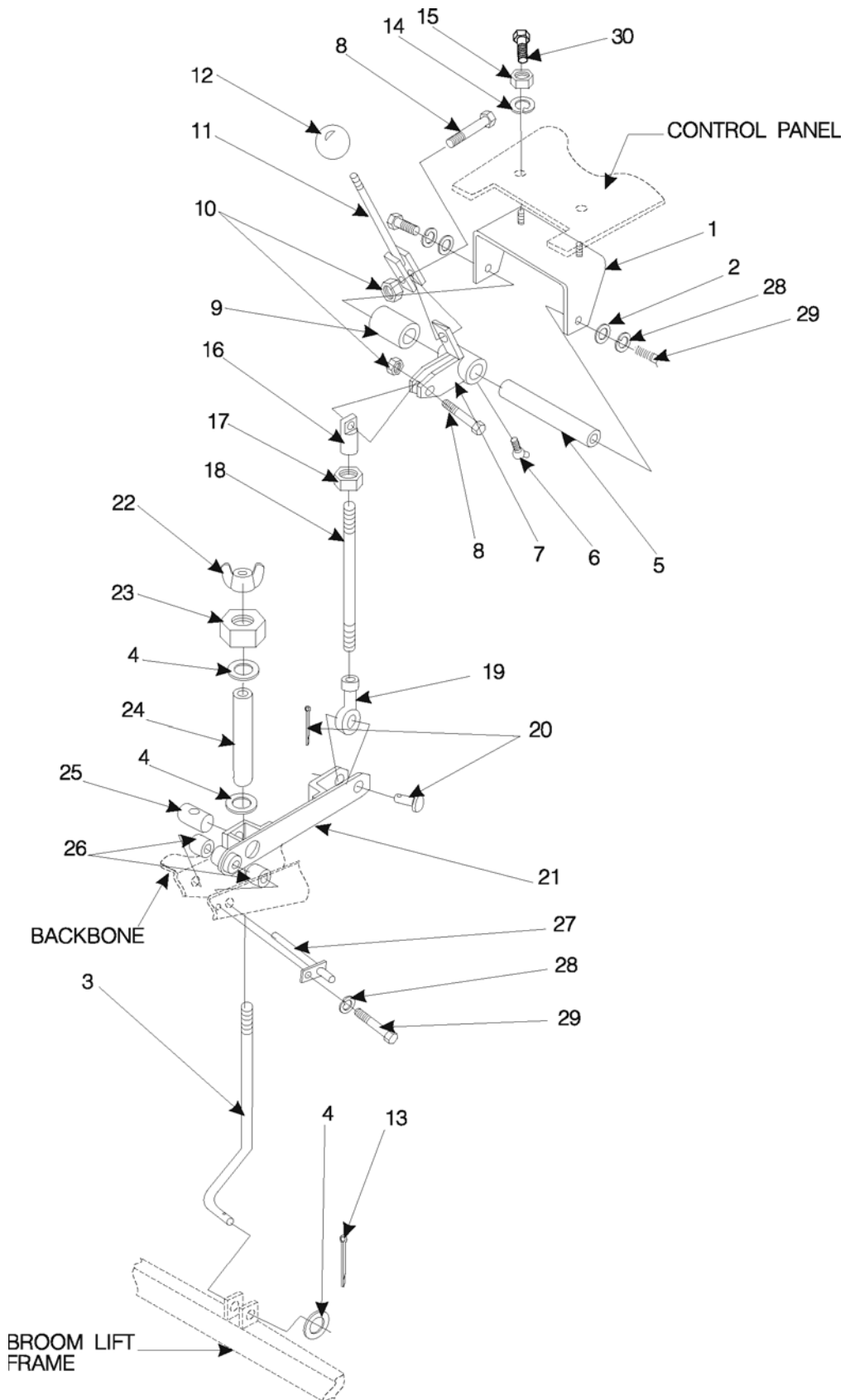

Item	Ref. No.	Qty	Description
1	8-08-00645	1	Bracket, Main Broom Pivot
3	8-66-00161	1	Rod, Linkage (Main Broom)
4	2-00-00432	3	Flat Washer, 3/4 I.D.
5	8-70-05284	1	Shaft
6	2-00-02558	1	Lubrication Fitting, 45° 1/8 NPT
7	8-16-00035	1	Pivot Block
8	2-00-00234	2	Screw, 3/8-16 x 1.50 HHC
9	8-75-01177	1	Pivot Tube Spacer
10	2-95-04182	2	Nut, 3/8-16 Fiber Insert Hex
11	8-16-00034	1	Lever
12	8-39-00003	1	Knob
13	2-00-02436	1	Cotter Pin, 1.500 x 1.875
14	2-00-00530	2	Lock Washer, 5/16 Helical Spring
15	2-00-00585	1	Nut, 5/16-18 x .500 x .265 Hex
16	8-66-00141	1	Rod End
17	2-00-00591	1	Nut, 1/2-20 x .750 x .312 Hex Jam
18	8-66-00150	1	Rod, Control Rod Lift Linkage
19	8-66-00144	1	"MPB" Rod End # WF-8-32
20	8-55-08101	1	Clevis Pin #1/2-1.75 - E&E
21	8-16-00037	1	Lift Linkage
22	2-00-04891	1	Wing Nut, 3/4-10 Thread
23	8-39-00011	1	Torque Knob
24	8-75-01180	1	Spacer
25	8-55-08099	1	Pivot Pin
26	8-75-01178	2	Spacer, .78 x .97
27	8-16-00038	1	Pivot Shaft
28	2-00-00518	3	Lock Washer, 1/4 Helical Spring
29	2-00-00221	3	Screw, 1/4-20 x 3/4 HHC
30	2-00-00208	2	Screw, 5/16-18 x 3/4

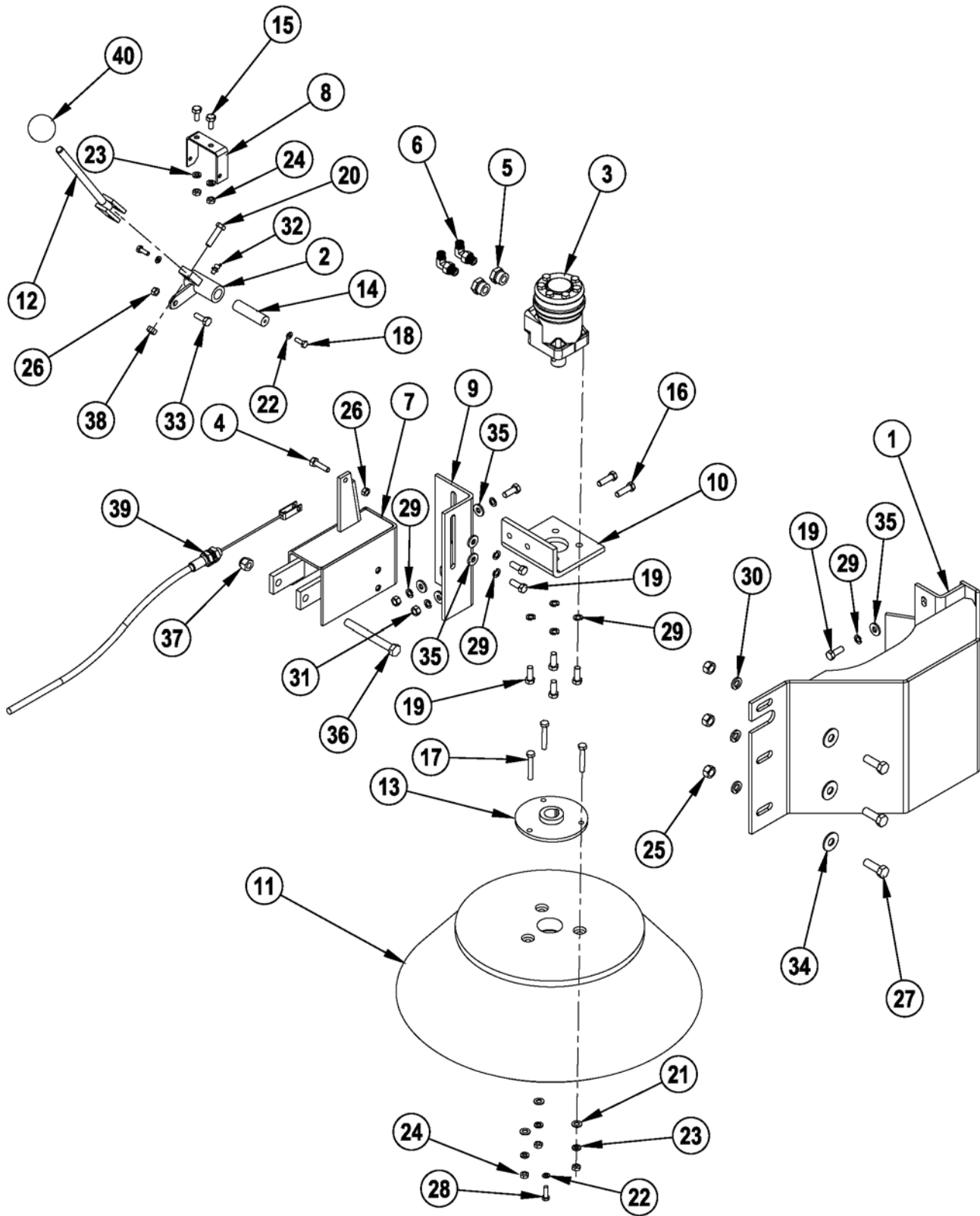

Item	Ref. No.	Qty	Description
1	56516809	1	Weldt, Side Broom Guard
2	56516810	1	Pivot-Side Broom
3	0882-047	1	Side Broom Motor
4	2-00-00207	1	Screw, Hex Head 5/16-18 X 1.25"
5	2-00-04915	2	Fitting-Reducer Sae 10 / Sae 6
6	2-00-04926	2	Fitting-90 Sae6 To Ors4
7	8-03-04282	1	Weldt-Side Broom Arm Rh
8	8-08-00646	1	Bracket-Side Broom Pivot
9	8-08-00725	1	Bracket-Side Brm Lift Arm
10	8-08-00726	1	Bracket-Side Broom Lift Arm
11	8-08-03211	1	Side Broom-Nylon
12	8-16-00034	1	Broom Lift Lever
13	8-25-06008	1	Flange-Curb Broom
14	8-70-05285	1	Shaft-Side Broom Pivot
15	2-00-00208	2	Screw, 5/16-18 X .750 Hhc
16	2-00-00209	2	Bolt, Hex Head, 3/8-16 X 1 1/4 Ss
17	2-00-00218	3	Bolt-Hex Head, 5/16-18
18	2-00-00221	2	Bolt-Hex Head, Finished, 1/4-20x3/4 Lg
19	2-00-00233	9	Bolt-Hex Head, Finished, 3/8-16 X 1.00
20	2-00-00234	1	Screw, 3/8-16 X 1-1/2 Hhc
21	2-00-00409	3	Flat Washer, .687 X .344 X .062
22	2-00-00518	3	Washer,Lock,1/4" Helical Spring
23	2-00-00530	5	5/16" Lock Washer
24	2-00-00585	5	5/16-18, Hex Nut
25	2-00-00596	3	Nut, Hex Head, 1/2-13 X .44 Lg
26	2-00-00644	2	Nut, Hex, Insert Fiber, 5/16-18
27	2-00-01254	3	Screw, Hex, 1/2-13 X 1.50
28	2-00-01490	1	1/4-20 X 0.875", Hex Head Screw
29	2-00-02310	11	Washer-Lock, 3/8", Helical Spring
30	2-00-02312	3	Washer, 1/2" Lock
31	2-00-02360	2	Nut, Hex, 3/8-16
32	2-00-02558	1	Grease Fitting
33	2-00-02708	1	Screw, Hex Head, 5/16-18 X 1.00"
34	2-00-04159	3	Washer, Flat 1-3/8 X 9/16 X 7/64
35	2-00-04801	7	Flat Washer, 1.00 X .39 X .06
36	2-00-04914	1	Screw 1/2-13 X 4.5" Lg
37	2-00-04936	1	Locknut-Elastic, 1/2-13
38	2-95-04182	1	Nut, Hex, Stop, 3/8-16
39	8-10-00028	1	Cable-Fwd / Rev
40	8-27-07118	1	Frame
41	8-39-00003	1	Knob

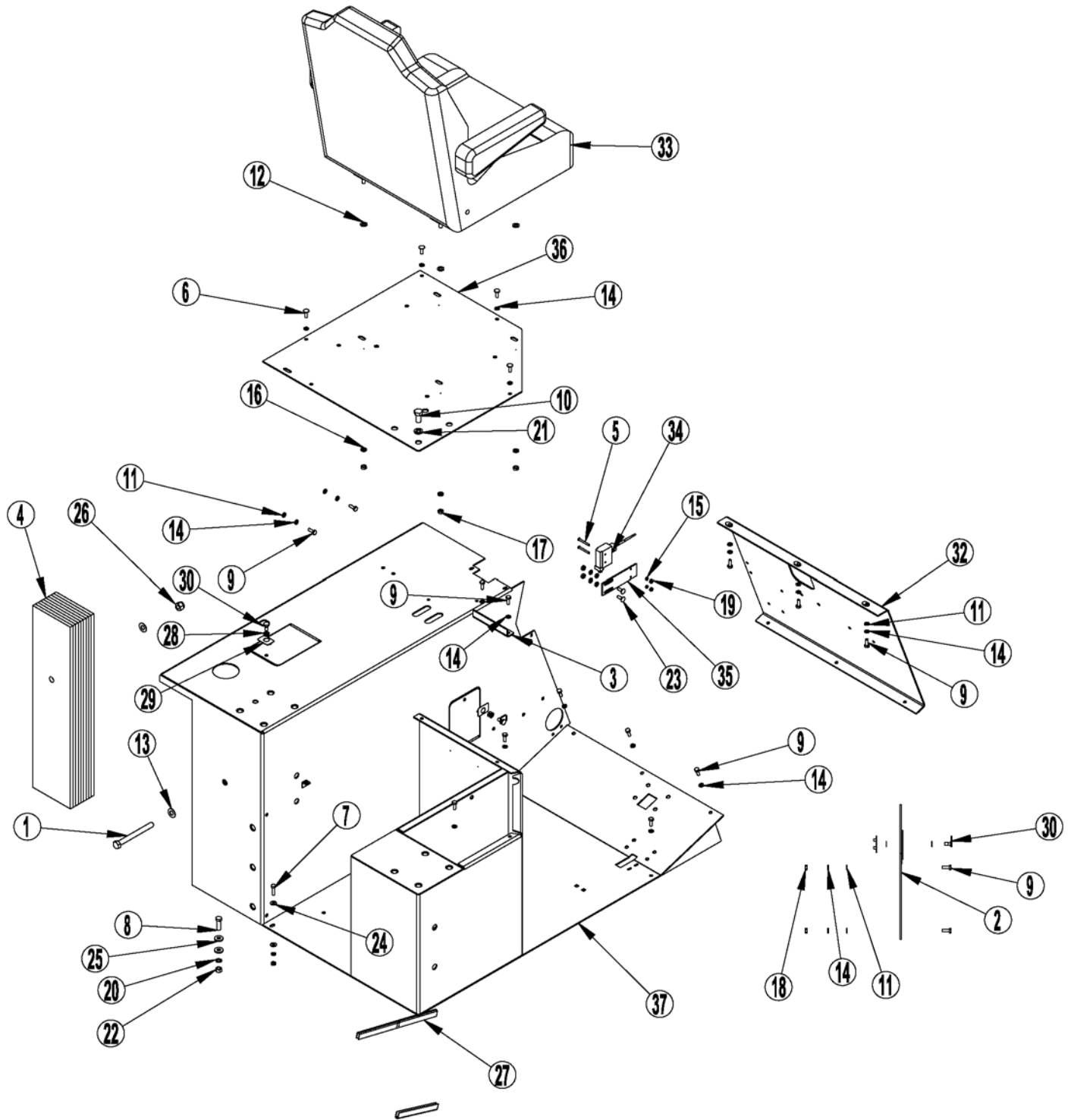

Item	Ref. No.	Qty	Description
1	56003282	1	Scr, Hex 1/2-13 X 5.00 Grade 8
2	56516791	1	Battery Door
3	56516793	1	Bracket-Battery Hold Down
4	56516794	9	Weight
5	2-00-00090	2	Screw, #8-32 X 1.50 Lg, Rhm
6	2-00-00183	4	Screw, 1/4-20, Round Head
7	2-00-00205	1	Bolt-Hex Head, Finished, 1/4-20
8	2-00-00209	1	Bolt, Hex Head, 3/8-16 X 1 1/4 Ss
9	2-00-00221	15	Bolt-Hex Head, Finished, 1/4-20x3/4 Lg
10	2-00-00239	1	Screw, 1/2-13 X 1.000 Hhc
11	2-00-00407	9	Washer, Flat 1/4
12	2-00-00409	4	Flat Washer, .687 X .344 X .062
13	2-00-00427	2	Washer, .50 Id X 1.0 Od X .06
14	2-00-00518	22	Washer,Lock,1/4" Helical Spring
15	2-00-00529	2	Washer, #8 Lock
16	2-00-00530	4	5/16" Lock Washer
17	2-00-00585	4	5/16-18, Hex Nut
18	2-00-00594	5	Nut, Hex 1/4-20
19	2-00-00602	2	Hex Nut
20	2-00-02310	1	Washer-Lock, 3/8", Helical Spring
21	2-00-02312	1	Washer, 1/2" Lock
22	2-00-02360	1	Nut, Hex, 3/8-16
23	2-00-03575	2	Bolt-Carr, .25-20 X .75 Gr5 Zn
24	2-00-03702	2	Washer, .625 X .281 X .063
25	2-00-04801	2	Flat Washer, 1.00 X .39 X .06
26	2-00-04936	1	Locknut-Elastic, 1/2-13
27	7-21-04031	3	Edging-Brush Drive Support
28	7-23-03106	6	Washer-Screw-Captivated
29	7-23-03108	3	U Clip-Screw-Captivated
30	7-23-03113	3	Fastener, Qtr. Turn
31	8-27-07118	1	Frame
32	56516795	1	Kick Wall Weldment
33	8-69-00019	1	Seat- Suspension
[]	8-03-04320	1	Arm Rest Kit (RH + LH)
34	8-82-00058	1	Switch
35	56516789	1	Bracket, Hopper Switch
36	56516790	1	Panel, Seat Deck
37	56516792	1	Weldmt-1pc Drive Comp
[]	8-13-07068	2	Clip
[]	2-00-00686	1	Wrench, 3/4-9/16
[]	2-00-03061	2	Screw, #10-24 x 1/2 THM
[]	2-00-00605	2	Nut, Hex MS #10-24 x .375 x .125
[]	2-00-00519	2	Lock Washer, #10 Helical Spring

[] = Not Shown

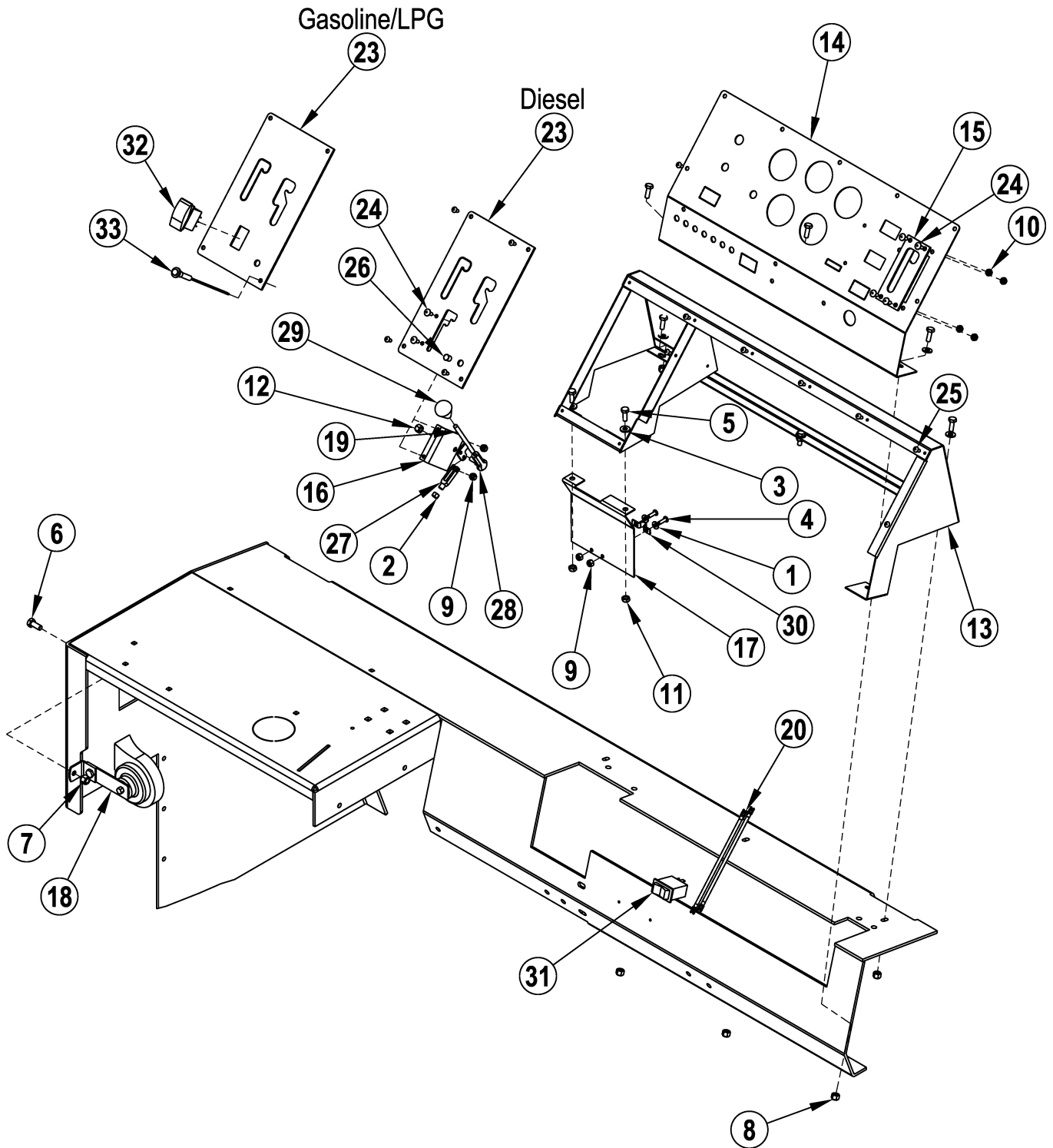

Item	Ref. No.	Qty	Description
1	56001954	2	Wsh, Fit SAE #10 (Diesel)
2	56001987	1	Nut, Hex Machine 10-32 (Diesel)
3	56002098	6	Wsh, Fit SAE 1/4 (qty of 4 on Gasoline & LPG)
4	56002124	2	Scr, Pan Phil 10-24 X .62 (Diesel)
5	56002155	8	Scr, Hex 1/4-20 X .75 (qty of 6 on Gasoline & LPG)
6	56002667	1	Scr, Hex 5/16-18 X .75
7	56002701	1	Nut, Hex Nyl Loc 5/16-18
8	56002708	6	Nut, Hex Nyl Loc 1/4-20
9	56002768	4	Nut, Hex Nyl Loc 10-24 (Diesel)
10	56002832	4	Nut, Hex Nyl Loc-Thin 10-24
11	56002840	2	Nut, Hex Nyl Loc-Thin 1/4-20 (Diesel)
12	56003284	1	Nut, Hex Nyl Loc 1/4-28 (Diesel)
13	56516825	1	Instrument Housing
14	56516826	1	Face Plate Instrument Comp
15	56516829	1	Backing Plate Brush Control
16	56516830	1	Bracket (Diesel)
17	8-08-00735	1	Bracket Throttle Cable (Diesel)
18	8-32-09013	1	Horn
19	8-41-05074	1	Lever-Throttle Control Weldt (Diesel)
20	8-90-07357	2	Wire Wt Gage To Fuel Gage (Diesel)
[]	8-90-07361	1	Wire Td-1 6 to 7 To M286 to M4
[]	8-90-07385	1	Wire Jumper
23	56516827	1	Face Plate Main Broom Ctrl (Diesel)
	56516828	1	Face Plate, MB Control/Throttle (Gasoline & LPG)
24	2-00-03061	6	Screw, #10-24 X 1.00 Truss Head (qty of 4 on Gasoline & LPG)
25	2-00-03466	12	Screw #10-16 x 1/2 Self Tapping
26	2-00-04757	1	Plug Button, .375 Dia. (Diesel)
27	7-14-07006	1	Clevis (Diesel)
28	7-25-02050	1	Rod End-Spherco (Diesel)
29	7-39-00017	1	Knob-Solution Control (Diesel)
30	8-13-07094	1	Conduit Clamp (Diesel)
31	8-82-00062	1	Switch-Rocker (SPST)
32	8-82-00074	1	Switch Body & Actuator-1 piece (Gasoline & LPG)
33	7-11-04080	1	Check Engine Light (MIL) (Gasoline & LPG)

[] = Not Shown

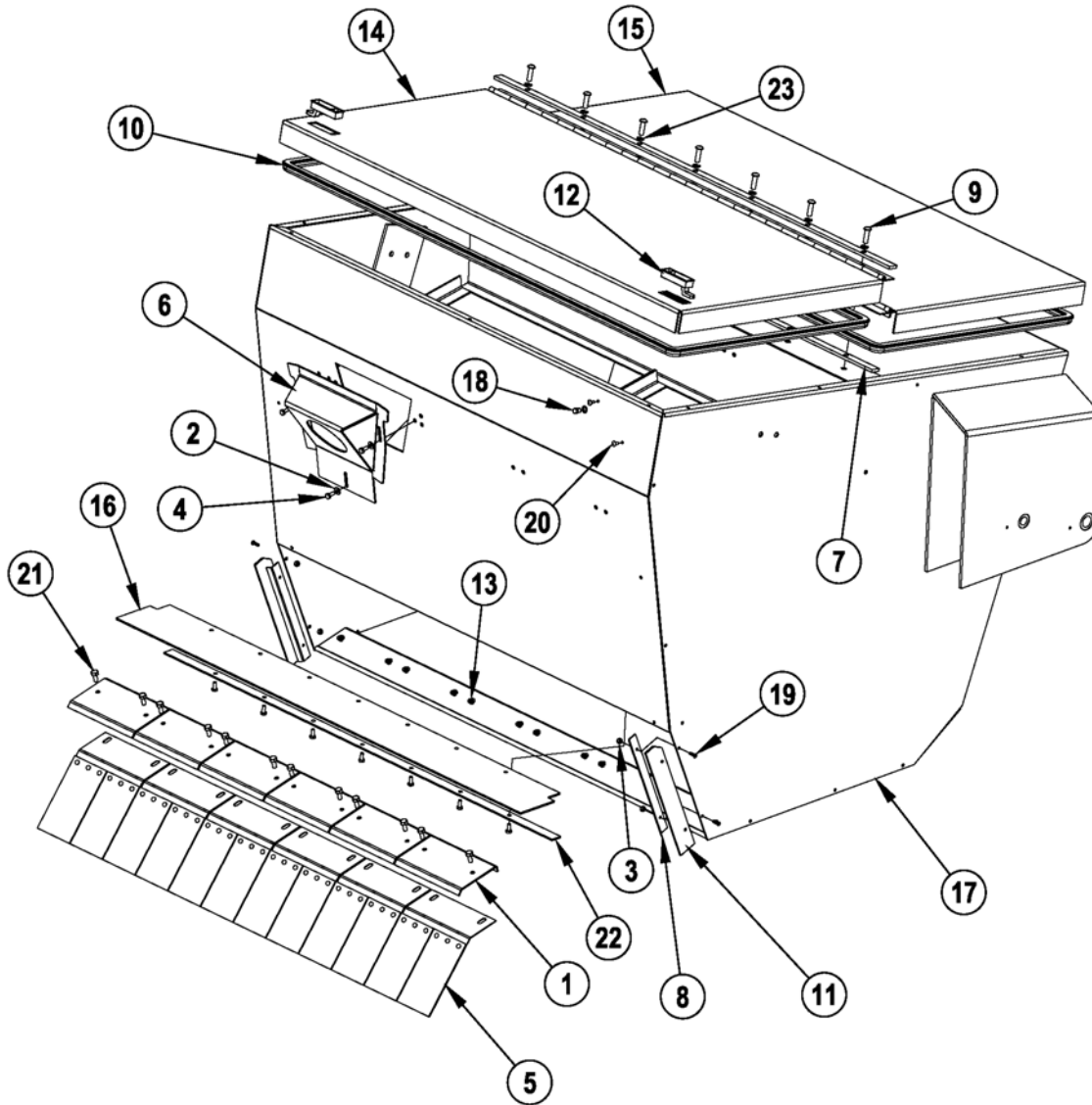

Item	Ref. No.	Qty	Description	Item	Ref. No.	Qty	Description
1	8-13-07084	6	Clamp Flap Hopper Bottom	13	2-00-00530	12	5/16" Lock Washer
2	56002098	3	Wsh, Flt Sae 1/4	14	56516771	1	Cover Weldment, Upper
3	56002836	6	Nut, Hex Nyl Loc Ss 10-24	15	56516761	1	Cover, Weldment
4	56002922	10	Scr,Hex Hd Loc 1/4-20x.62	16	8-25-08179	1	Flap Hopper Upper
5	56109460	6	Flap Hopper	17	56516760	1	Hopper Weldment
6	56516770	1	Weldt Blower Mounting Plate	18	2-00-03778	1	Plug, 1/8 Npt
7	56516773	2	Spacer	19	2-00-04794	4	Screw, #10-24 X .63 Bhs
8	56516775	2	Clamp, Hopper Side	20	2-00-03061	2	Screw, #10-24 X 1.00 Truss Head
9	2-00-04667	7	Scr, Button Soc 3/8-16 X 1.25	21	2-00-00208	12	Screw, 5/16-18 X .750 Hhc
10	3-73-00060	2	Seal Hopper Cover	22	56516767	1	Strap, Primary Deflector Flap
11	8-25-08180	2	Flap Hoppe Side	23	2-00-02310	7	Washer-Lock, 3/8", Helical Spring
12	8-41-00044	2	Latch				

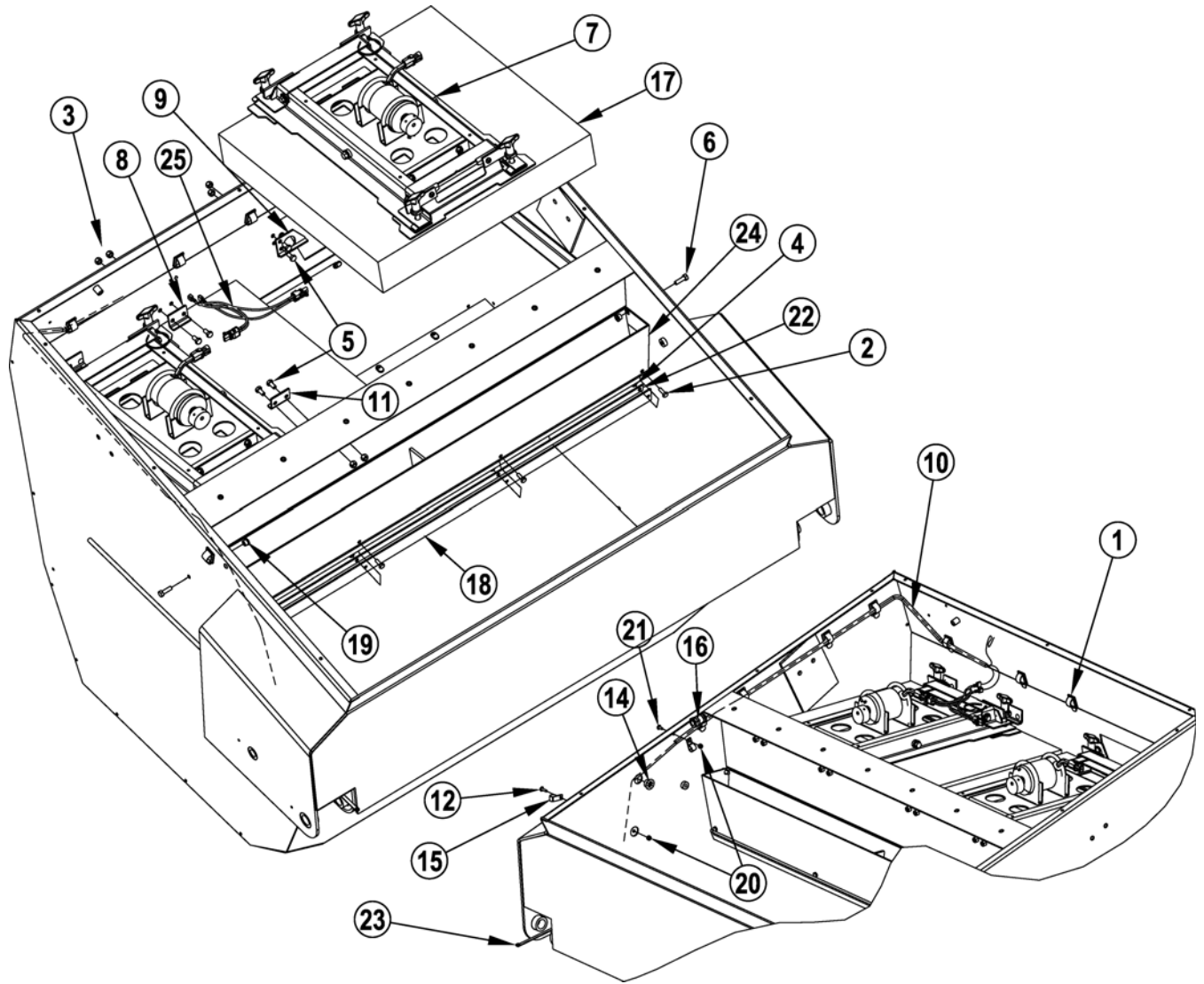

Item	Ref. No.	Qty	Description	Item	Ref. No.	Qty	Description
1	7-13-07096	8	Clamp-Adjustable	14	8-09-01082	1	Bushing, Star
2	56002155	4	Scr, Hex 1/4-20 X .75	15	2-00-04210	2	Clamp
3	56002701	16	Nut, Hex Nyl Loc 5/16-18	16	8-09-01083	1	Connector, Bulkhead
4	56002708	4	Nut, Hex Nyl Loc 1/4-20	17	8-24-04123-1	2	Filter
5	56002035	16	Scr, Hex 5/16-18 x .62	18	8-25-08228	1	Flap - Hopper Vac Chamber
6	56003073	2	Scr, Hex Hd Loc 5/16-18x1.00	19	7-23-03056	2	Nut
7	56109440	2	Filter Shaker Assembly	20	2-00-01246	2	Nut-#10-24 Elastic Stop Nut
8	56109450	7	Bracket Filter Clamp Rr	21	2-00-03061	1	Screw, #10-24 X 1.00 Truss Head
9	56109456	1	Bracket Shaker Weldt	22	56516777	1	Strap - Hopper Vac Chamber
10	0875-108	1	Wire Assembly Hopper	23	2-00-04345	1	Ty-Rap (Thomas&Betts Ty-28m)
11	56109443	4	Bracket Filter Clamp Ft	24	56516776	1	Weldment, Air Guide
12	2-00-03063	1	Screw, #10-24 X .75, Round Head	25	56109462	1	Jumper Shaker Motor

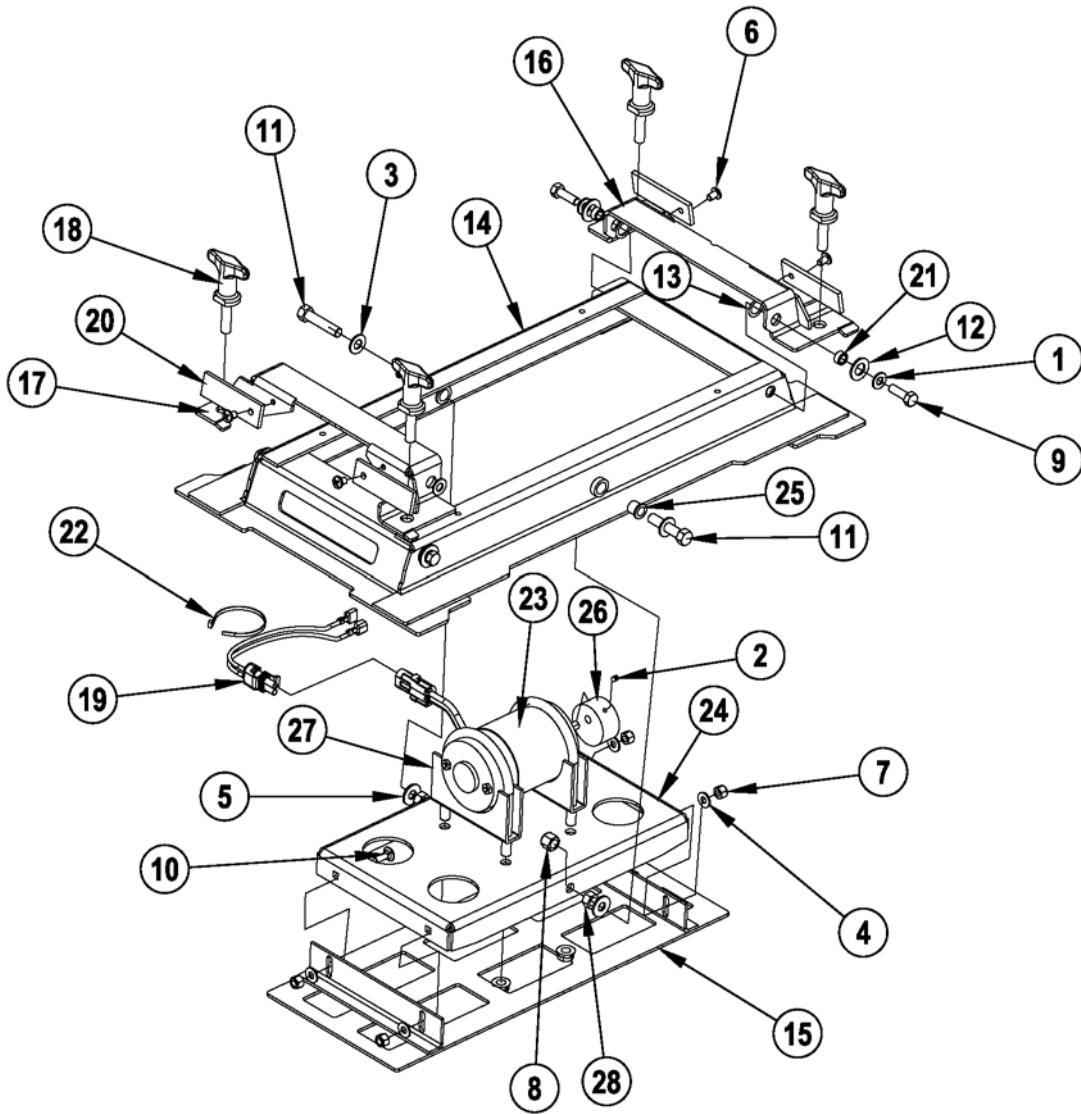

Item	Ref. No.	Qty	Description
1	56001939	4	Wsh, Flt Sae 5/16
2	56002015	2	Scr, Soc Set Loc 10-24 X .25
3	56002063	2	Wsh, Flt Sae 3/8
4	56002098	4	Wsh, Flt Sae 1/4
5	56002220	2	Wsh, Flt Std 5/16
6	56002462	4	Scr, Pan Phil 1/4-20 X .38
7	56002708	4	Nut, Hex Nyl Loc 1/4-20
8	56002769	2	Nut, Hex Nyl Loc 3/8-16
9	56003073	4	Scr,Hex Hd Loc 5/16-18x1.00
10	56003715	4	Scr, Carriage Ss 1/4-20 X .75
11	56003771	2	Scr,Hex Hd Loc 3/8-16x1.75 Grade 8
12	56009003	4	Wsh, Flt .516 X .938 X .075
13	56009265	4	Washer, Wave .531
14	56109441	1	Filter Shaker Wedgt
15	56109444	1	Shaker Weldment
16	56109446	1	Clamp Filter Shaker Weldt Rr
17	56109448	1	Clamp Filter Shaker Weldt
18	56109459	4	Knob 3/8-16 Male Thread
19	56109462	1	Jumper Shaker Motor
20	56109464	4	Bar Lock Knob
21	56320595	4	Bushing .32x.50x.28
22	56478246	1	Tie, Cable
23	56508664	1	Motor, 12vdc
24	56508705	1	Plate Shaker Motor Mtg
25	56508737	2	Bearing, Fl .500x.375x.500
26	56508772	1	Eccentric
27	56508887	2	Clamp Muffler 3" X 3/8-16
28	2-00-02360	2	Nut, Hex, 3/8-16

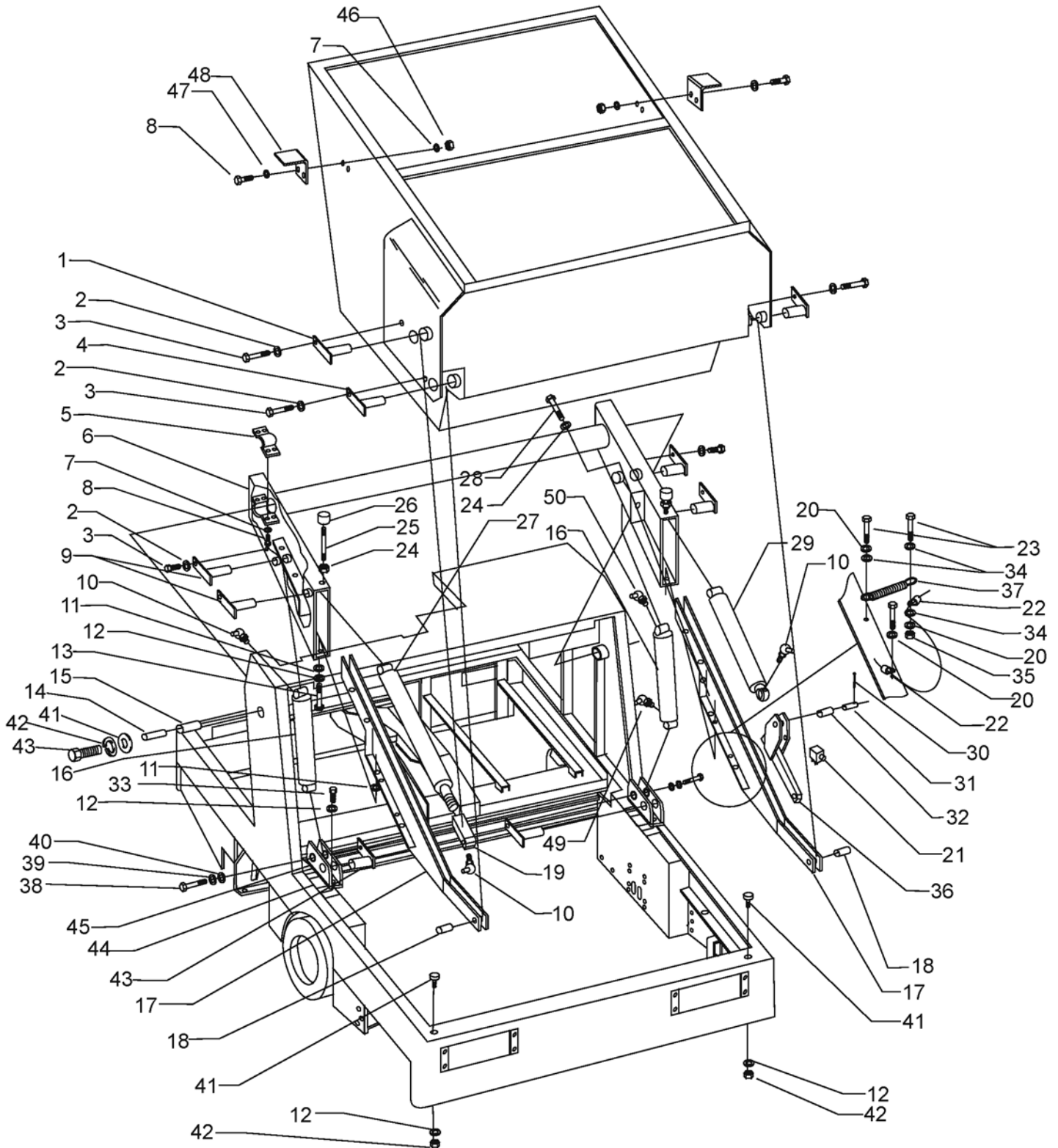

Item	Ref. No.	Qty	Description
1	56516823	1	Hopper Dump Pin
2	2-00-00518	7	Lock Washer, Helical Spring 1/4 Med
3	2-00-00221	7	Screw, 1/4 - 20 x .750 HHC
4	56516822	2	Hopper Pivot Pin
5	8-13-07103	2	Pivot Pin Half Clamp
6	56516819	1	Arm Pivot Bracket Assembly
7	2-00-02310	12	Lock Washer, Helical Spring 3/8 Med
8	2-00-00234	8	Screw, 3/8 - 16 x 1.000 HHC
9	56516820	4	Pin (Upper)
10	2-00-02558	4	Lubrication Fitting, 45° 1/8 NPT
11	2-00-04159	8	Flat Washer, 1.375 x .562 x .109
12	2-00-02312	8	Lock Washer, Helical Spring 1/2 Med
13	2-00-01254	6	Screw, 1/2 - 13 x 1.500 HHC
14	8-55-08107	2	Pin (Arm Pivot)
15	2-00-04893	2	Sleeve Bearing, 2.005 x 1.503 x 2.000
16	8-17-05029	2	Lift Cylinder
	0880-449	2	Seal Kit for Lift Cylinder
17	56516816	2	Lower Arm
18	2-00-04894	2	Sleeve Bearing, 1.254 x 1.003 x 2.500
19	8-14-01010	1	Clevis, Dump Cylinder
20	2-00-00519	5	Lock Washer, Helical Spring #10 Med
21	8-82-00050	1	Switch Lift Arm Lockout
22	2-00-04378	2	Clip, .281
23	2-00-00056	3	Screw, #10 - 24 x .750 RHM
24	2-00-02371	2	Nut, Hex Hvy. Jam 1/2 - 13 x .875 x .296
25	8-80-05014	2	Stud, 1/2-13 UNF-2A
26	7-78-05009	2	Stop Pad
27	8-17-05028	1	Dump Cylinder
	0880-505	1	Seal Kit for Dump Cylinder
28	2-00-04967	4	Screw, 1/2 - 13 x 2.500 HHM
29	8-17-05030	1	Rotation Cylinder
	0880-450	1	Seal Kit for Rotation Cylinder
30	2-00-02436	1	Cotter Pin, .187 x 1.750
31	8-55-08103	1	Hopper Rotate Pin
32	8-06-01083	1	Bushing,
33	2-00-00240	4	Screw, 1/4 - 13 x 1.250 HHC
34	2-00-00426	3	Flat Washer, .500 x .218 x .062
35	2-00-00605	1	Nut, Hex MS #10 - 24 x .375 x .125
36	56516817	1	Rotate Cylinder Bracket
37	7-76-00050-1	1	Spring
38	2-00-00213	2	Screw, 5/16 - 18 x .625 HHC
39	2-00-00530	2	Lock Washer, Helical Spring 5/16 Med
40	2-00-00409	2	Flat Washer, .687 x .343 x .062
41	8-50-05054	2	Rubber Pad
42	2-00-00596	2	Nut, Hex 1/2 - 13
43	56516820	2	Pin (Lower)
44	8-71-00017	1	Shim
45	56516824	2	Adjustable Lift Arm Bracket
46	2-95-04689	2	Washer
47	2-00-02310	2	Washer, 3/8 Lock
48	56516821	2	Bracket, Hopper Stop

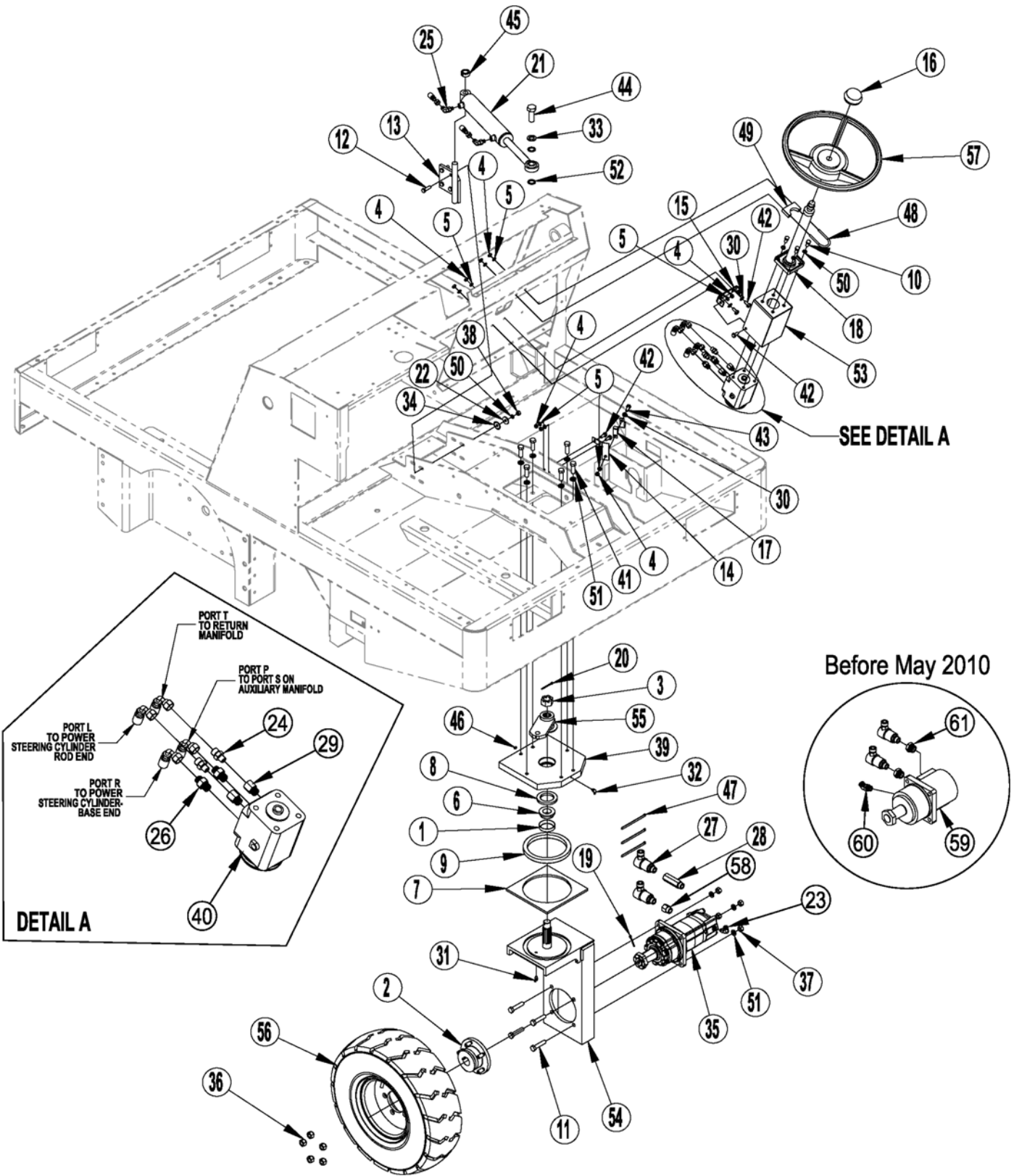

Item	Ref. No.	Qty	Description	Item	Ref. No.	Qty	Description
1	2-00-04621	1	Bearing Cup	31	2-00-02558	1	Grease Fitting
2	0860-536	1	Hub/Stud Assy - Rear Wheel	32	2-00-02559	1	Grease Fitting- 1/4-28 X 90°
[]	8-33-09081	1	Hub Only (Service)	33	2-00-00522	1	Lock Washer
[]	7-80-05056-1	5	Studs (Service)	34	2-00-03829	4	Lock Washer, 3/8 Int./Ext. Tooth
3	2-00-05026	1	1" X 14 Slotted Nut	35	56109709	1	Wheel Motor NOTE 1
4	2-00-00585	9	5/16-18, Hex Nut	[]	56109718	1	Seal kit (for 56109709)
5	2-00-00530	9	5/16" Lock Washer	[#]	56463039	1	Nut (for 56109709)
6	2-00-02079	1	Bearing Cone W/ Seal	[#]	8-70-00026	1	Key (for 56109709)
7	8-68-05097	1	Bearing Seal	36	56009116	5	Nut-Wheel
8	8-68-05098	1	Bearing Seal	37	2-00-00596	4	Nut, Hex Head, 1/2-13 X .44 Lg
9	2-00-04455	1	Bearing, Thrust	38	2-00-02360	4	Nut, Hex, 3/8-16
10	2-00-00232	4	Bolt-Hex Head, Finished, 3/8-16	39	8-58-05269	1	Plate, Rear Wheel Pivot
11	2-00-00242	4	Bolt, 1/2-13 X 2.00 Long	40	8-60-05023	1	Pump, Power Steering
12	2-00-00209	4	Bolt, Hex Head, 3/8-16 X 1 1/4 Ss	41	2-00-01254	6	Screw, Hex, 1/2-13 X 1.50
13	8-08-00727	1	Bracket, Cylinder Pivot	42	2-00-00208	6	Screw, 5/16-18 X .750 Hhc
14	8-08-00733	1	Bracket, Cylinder Pivot	43	2-00-02708	1	Screw, Hex Head, 5/16-18 X 1.00"
15	8-08-00728	1	Bracket, P/S Unit Mount	44	2-00-05341	1	Screw, Hhc .75-10 X 2.00 Gr5 Zn
16	8-11-00022	1	Cap Steering Wheel	45	8-15-01003	1	Set Screw Collar
17	2-00-04564	2	Clamp, Cable	46	2-00-00256	1	Set Screw, 1/4-20 X .38 Hs-Kcp
18	8-70-05287	1	Column, Steering, Assembly	47	2-00-04345	3	Ty-Rap (Thomas&Betts Ty-28m)
19	2-00-00776	1	Cotter Pin (1/8 Dia. X 1-1/2 Lg.)	48	8-13-07085	1	U-Bolt, 1/4-20
20	2-00-04803	1	Cotter Pin (1/8 Dia. X 2 Lg.)	49	8-08-00578	1	W/D, U Bolt Ass'y
21	8-17-05029	1	Cylinder	50	2-00-02310	8	Washer-Lock, 3/8", Helical Spring
22	2-00-03266	4	Fan Washer	51	2-00-02312	10	Washer, 1/2" Lock
23	2-00-04892	1	Fitting-90 Elbow NOTE 1	52	2-00-00432	2	Washer, Flat, 3/4"ld
24	2-00-04895	2	Fitting-Straight Connector	53	56516787	1	Weldment - Stg Cntrl Housing
25	2-00-04892	2	Fitting-90° Elbow (O-Ring)	54	8-92-00043	1	Weldment-Drive Wheel Yoke
26	2-00-04918	2	Fitting, -6 SAE X -4 Ors, Str.	55	56516788	1	Weldment, Steering Arm
27	2-00-05358	2	Fitting, -10 SAE X -10 Ors, Swivel	56	8-89-08059	1	Wheel, 21.50 Dia. Pneumatic
28	56109705	1	Adapter-Hydraulic Motor NOTE 1	[]	8-85-06022		Tire Only (Service)
29	2-00-04917	2	Fitting, Reducer, -6 Orb - -4 Orb	[]	8-70-00086		Tube (Service)
30	2-00-00409	3	Flat Washer, .687 X .344 X .062	[]	8-70-00067		Flap (Service)
				57	7-89-08041	1	Wheel, Steering
				58	56900602	1	Reducer O-Ring NOTE 1
				59	0885-054-1	1	Wheel Motor NOTE 2
				[]	8-70-00026	1	Key (for 0885-054-1)
				[]	0880-237	1	Shaft Seal Kit (for 0885-054-1)
				[]	0880-238	1	Motor Seal Kit (for 0885-054-1)
				60	2-00-04975	1	Fitting-8 SAE 45 Elbow NOTE 2
				61	8-03-02036	2	Fitting, -12 SAE X -8 SAE, Reducer Bushing NOTE 2

[] = Not Shown

= Revised or new since last update

NOTE 1: These items are only used after April 2010.**NOTE 2:** These items are only used before May 2010.

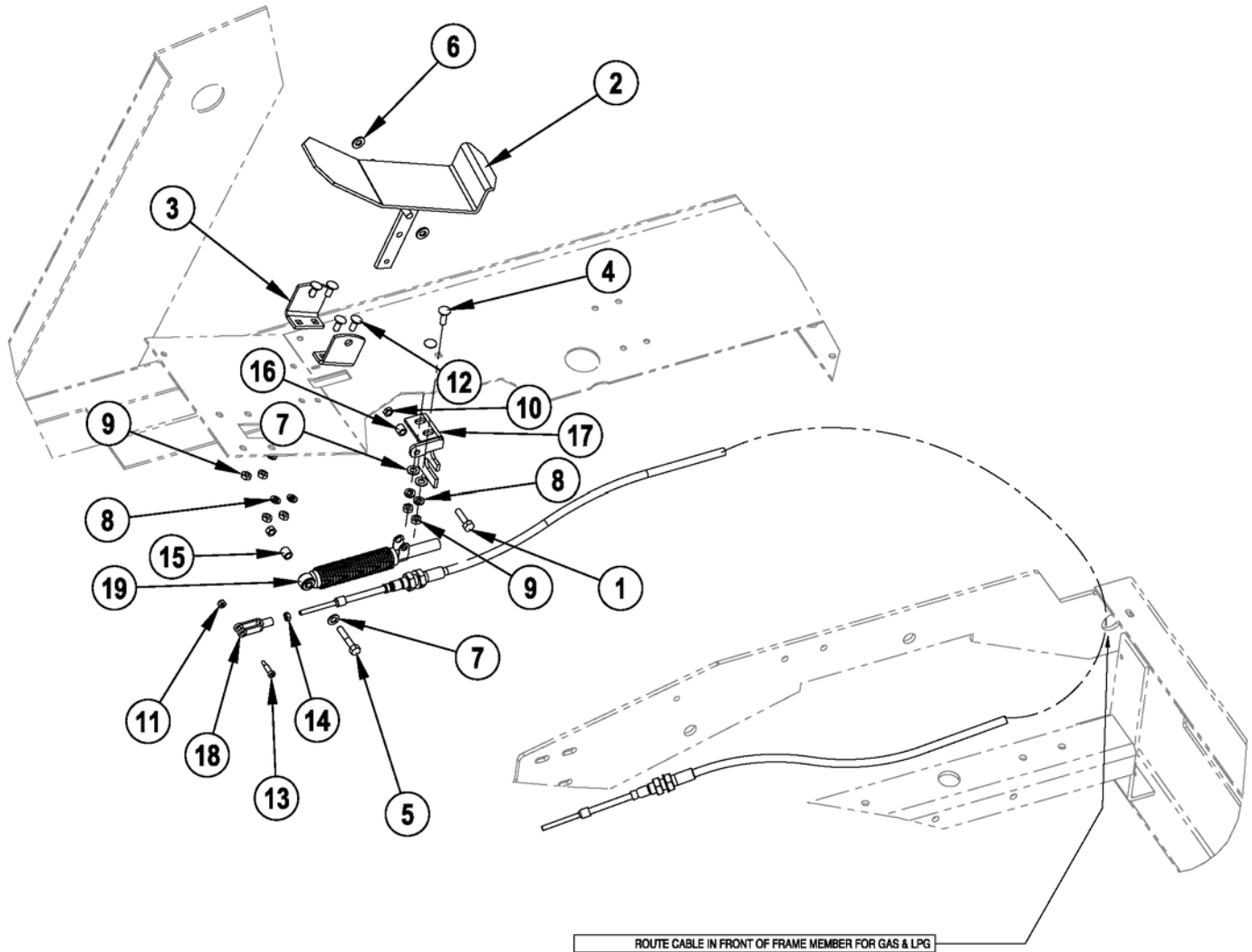

Item	Ref. No.	Qty	Description
1	2-00-00207	1	Screw, Hex Head 5/16-18 X 1.25"
2	56516833	1	Weldment Fwd/Rev Pedal
3	56516834	2	Bracket Fwd/Rev Pedal Pivot
4	2-00-00196	2	Bolt-Car, .31-18 X 1 Gr 5 Zn
5	2-00-00211	1	Bolt-Hex Head, Finished, 5/16-18
6	2-00-00402	2	Washer, 25/64" Id X 3/4" Od
7	2-00-00409	3	Flat Washer, .687 X .344 X .062
8	2-00-00530	6	5/16" Lock Washer
9	2-00-00585	6	5/16-18, Hex Nut
10	2-00-00644	2	Nut, Hex, Insert Fiber, 5/16-18
11	2-00-01246	1	Nut-#10-24 Elastic Stop Nut
12	2-00-03569	4	Bolt, Carriage
13	2-00-04563	1	Shoulder Screw 1/4" X 5/8"
14	2-95-01999	1	Nut- 1/4-28 Hex Jam
15	7-75-01130	1	Spacer
16	7-75-01209	1	Spacer
17	8-08-00898	1	Bracket-Fwd/Rev/Damper
18	8-14-01006	1	Clevis
19	8-17-05035	1	Lever damper Kyb

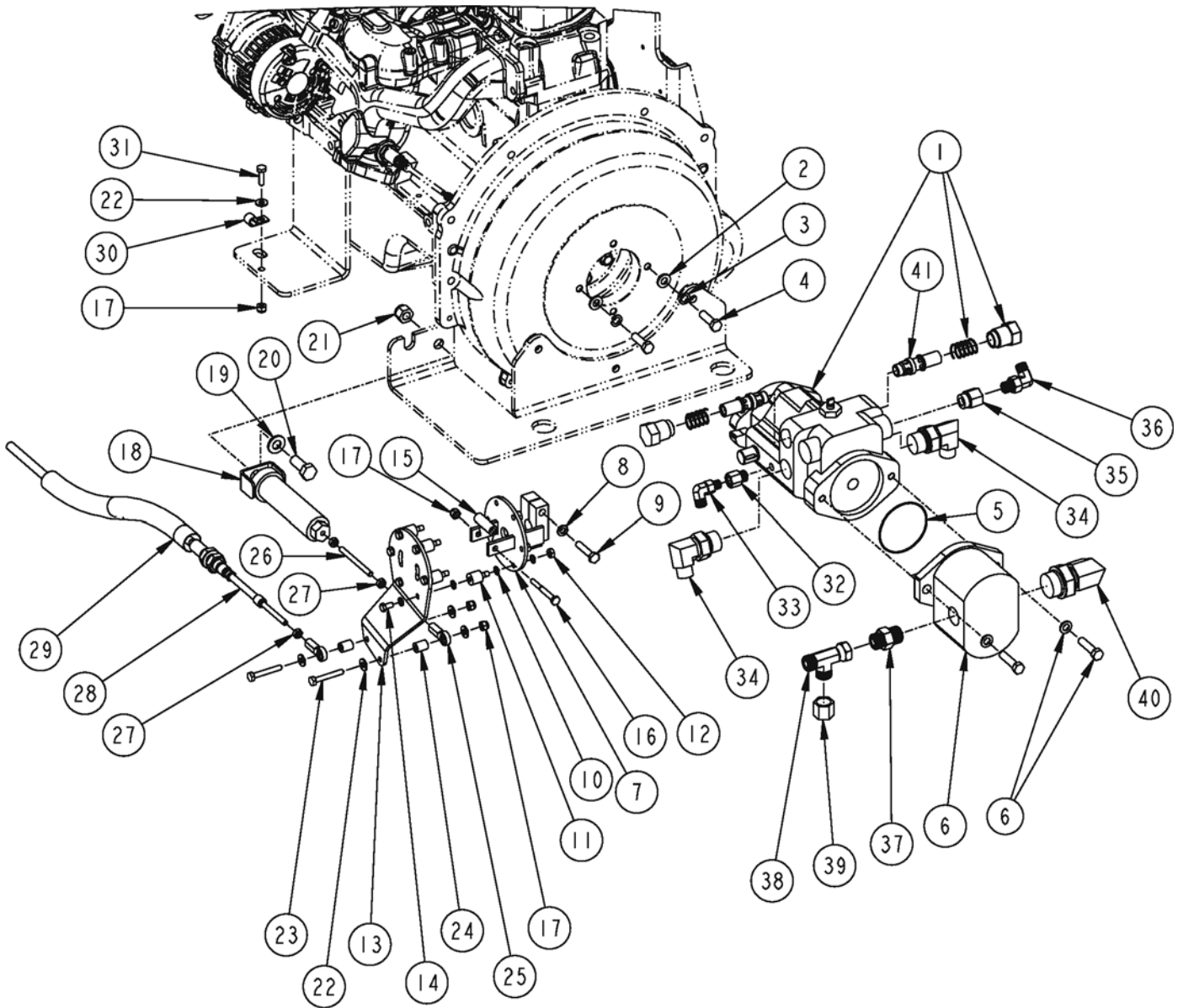

Item	Ref. No.	Qty	Description
1	8-60-05006-2	1	Drive Pump
2	2-00-00402	2	Flat Washer, .750 x .390 x .093
3	2-00-02310	2	Lock Washer, Helical Spring 3/8 Med
4	2-00-00209	2	Bolt, 3/8-16 x 1.25 Hex Head
5	0880-404	1	Kit, Pump Assembly
6	8-60-05022	1	Pump, Auxiliary (1.20 C.I.R.)
7	7-03-04105	1	Transmission Arm (Weldment)
8	2-00-00530	1	Lock Washer, 5/16
9	2-00-00225	1	Screw, 5/16-18 x 1.50 HHC
10	2-00-00501	24	Lock Washer, 1/4 Int.
11	7-75-01089	6	Spacer, Sandwich Mount
12	2-00-00594	6	Nut, Hex 1/4-20 x .437 x .218
13	7-58-05361	1	Plate, Hydrostat Arm
14	2-00-00219	6	Bolt, 1/4-20 x 1/2 Fin. Hex Head
15	7-75-01110	1	Spacer, Transmission Arm
16	2-00-00246	1	Screw, 1/4-20 x 2.25 HHC
17	2-00-00641	4	Nut, 1/4-20 Fiber Insert
18	8-16-00025	1	Centering Control
19	2-00-00405	1	Flat Washer, 1.062 x .531 x .093
20	2-00-00240	1	Screw, 1/2-13 x 1.25 HHC
21	2-00-04936	1	Lock Nut, 1/2-13 Elastic
22	2-00-03702	5	Washer, .625 x .281 x .063
23	2-00-01769	2	Screw, 1/4-20 x 1.75
24	7-75-01274	2	Spacer, 1/4" ID x 1/2" OD - 5/8"
25	7-25-02111	2	Rod End, 1/4 Female
26	7-66-00147	1	Rod, Centering Control Adjustment
27	2-95-01999	3	Nut, 1/4-28 Hex Jam
28	8-16-00068	1	Cable, Forward/Reverse
29	8-34-09038	1	Reflective Sleeve (1" dia. x 14")
30	2-00-04602	1	Clamp
31	2-00-01490	1	Screw, 1/4-20 x .875 Hex Head
32	2-00-04917	1	Fitting, -6 ORB to -4 ORB Reducer
33	2-00-04892	1	Fitting, 90° Elbow (O-Ring)
34	2-00-04922	2	Fitting, -8 ORS to -10 SAE 90° Elbow
35	2-00-04932	1	Fitting, Reducer
36	2-00-04926	1	Fitting, 9/16-18 x 9/16-18 Elbow
37	2-00-04974	1	Fitting, #8 ORS to #10 SAE Connector
38	2-00-04928	1	Fitting, -08 ORFS Run Tee
39	2-00-04957	1	Fitting, 8 ORS Cap
40	2-00-04920	1	Fitting, 90° Elbow
41	8-88-00065	2	Kit, Relief Valve

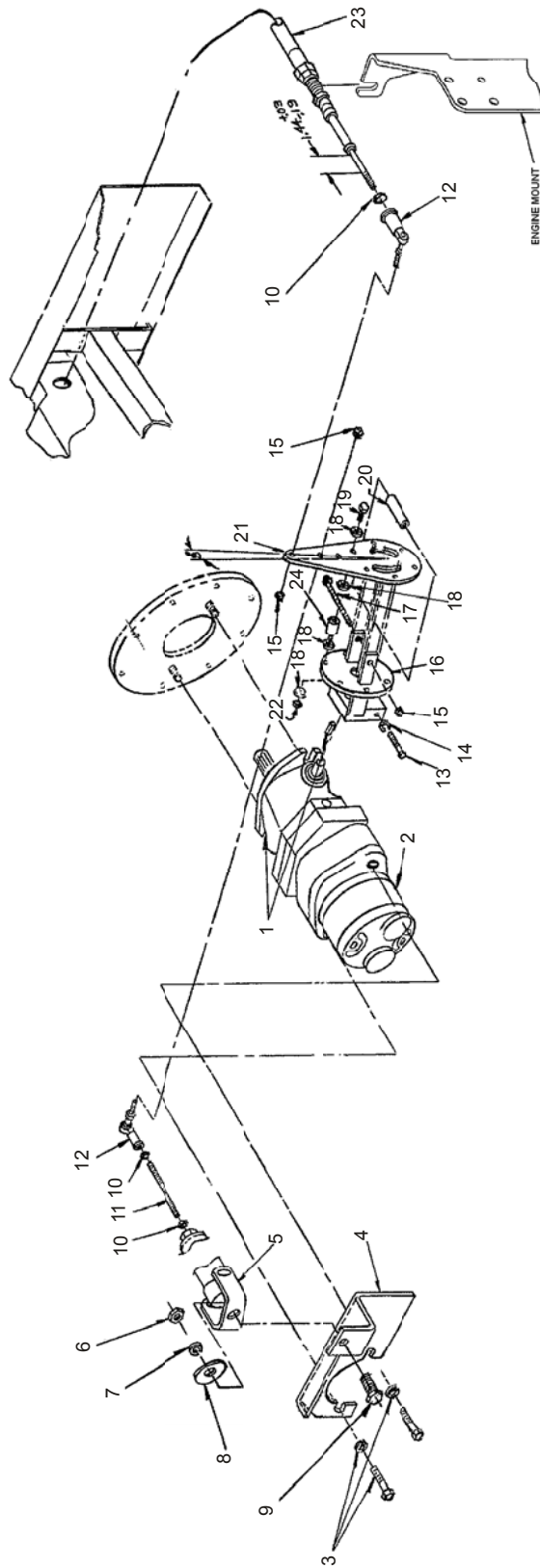

Item	Ref. No.	Qty	Description
1	8-60-05006-2	1	Pump, Piston (1.24 C.I.R.)
2	8-60-05022	1	Pump, Auxiliary (1.20 C.I.R.)
3	0880-404	1	Kit, Pump Assembly
4	56516832	1	Bracket, Hydroback
5	8-16-00025	1	Centering Control
6	2-00-00596	1	Nut, 1/2-13 Hex
7	2-00-02312	1	Lock Washer, 1/2 Helical Spring
8	2-00-00405	1	Flat Washer, 1/2
9	2-00-00240	1	Scr-1/2-13 x 1.25
10	2-95-01999	4	Nut, 1/4-28 Hex Jam
11	7-66-00147	1	Rod, 1/4-28 x 3.0
12	7-25-02050	2	Rod End, 1/4-28
13	2-00-00225	1	Screw, 5/16-18 x 1.50 HHC
14	2-00-00530	1	Lock Washer, 5/16 Helical Spring
15	2-00-00641	2	Nut, 1/4-20 Fiber Insert Hex
16	7-03-04105	1	Transmission Arm (Weldment)
17	2-00-01246	1	Nut, #10-24 Fiber Insert Hex
18	2-00-00501	24	Lock Washer, 1/4 Int.
19	2-00-00219	6	Screw, 1/4-20 x 1/2 HHC
20	7-75-01110	1	Spacer, Transmission Arm
21	7-58-05220	1	Plate, Transmission Arm
22	2-00-00594	6	Nut, 1/4-20 Hex
23	8-16-00045	1	Cable, Forward/Reverse
24	7-75-01089	6	Isolator

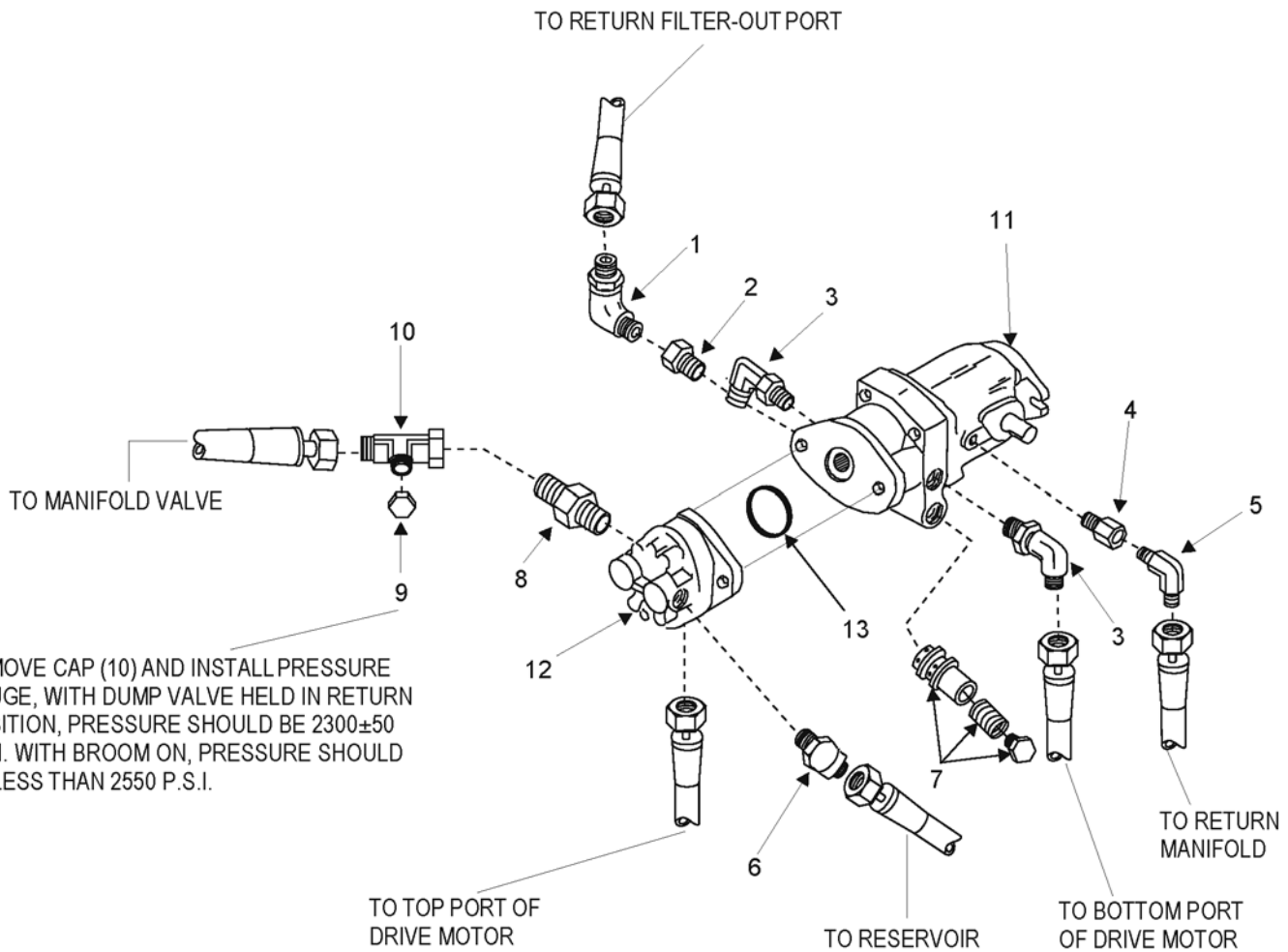

Item	Ref. No.	Qty	Description
1	2-00-04926	1	ORFS 90° Elbow 9/16-18
2	2-00-04932	1	ORFS Boss Reducer, 3/4-16 x 9/16-18
3	2-00-04922	2	ORFS 90° Elbow, 1 1/16-12 to 13/16-16
4	2-00-04917	1	ORFS Boss Reducer, 9/16-18 to 7/16-20
5	2-00-04892	1	Fitting, 90° Elbow
6	2-00-04920	1	Fitting, 90° Elbow
7	8-88-00065	2	Relief Valve Kit
8	2-00-04974	1	Fitting Straight
9	2-00-04957	1	Fitting Cap
10	2-00-04928	1	Fitting Tee
11	8-60-05006-2	1	Main Pump
12	8-60-05022	1	Auxiliary Pump
13	0880-404	1	Kit, Pump Assembly

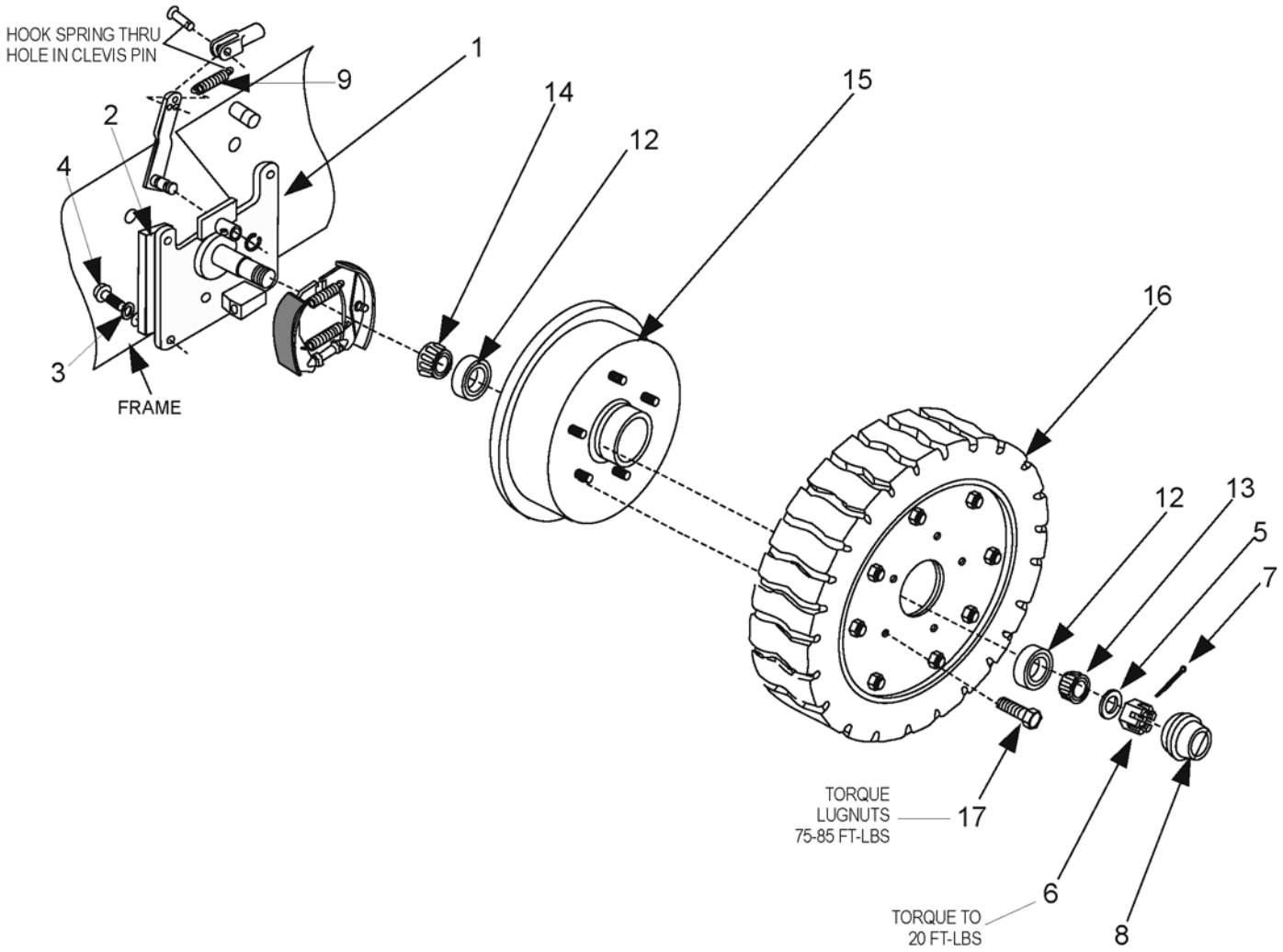

Item	Ref. No.	Qty	Description
1	0860-703	2	Axle, Front Wheel
2	8-75-01216	4	Spacer
3	2-00-00504	8	Lockwasher, 1/2 Int. Tooth
4	2-00-02693	8	Screw, 1/2-20 x 2.0 SHCS
5	2-00-05024	2	Thrust Washer
6	2-00-05026	2	Nut, Axle
7	2-00-02436	2	Cotter Pin
8	8-11-00030	2	Cap, Front Axle
9	8-76-00042	2	Spring
12	2-00-04621	4	Bearing Cup
13	2-00-04622	2	Bearing Cone
14	2-00-02079	2	Bearing Cone (sealed)
15	8-33-09089	2	Hub, Front Wheel
16	8-89-08054	2	Front Wheel Assy.
*	8-85-06022		Tire, Pneumatic 6 x 9
*	8-70-00086		Flap
*	8-70-00087		Tube
*	8-65-05016		Rim Assembly, 6 x 9 x 4
17	8-80-05035	10	Stud, 1/2 -20 w/Tapered Head

*-Service Parts

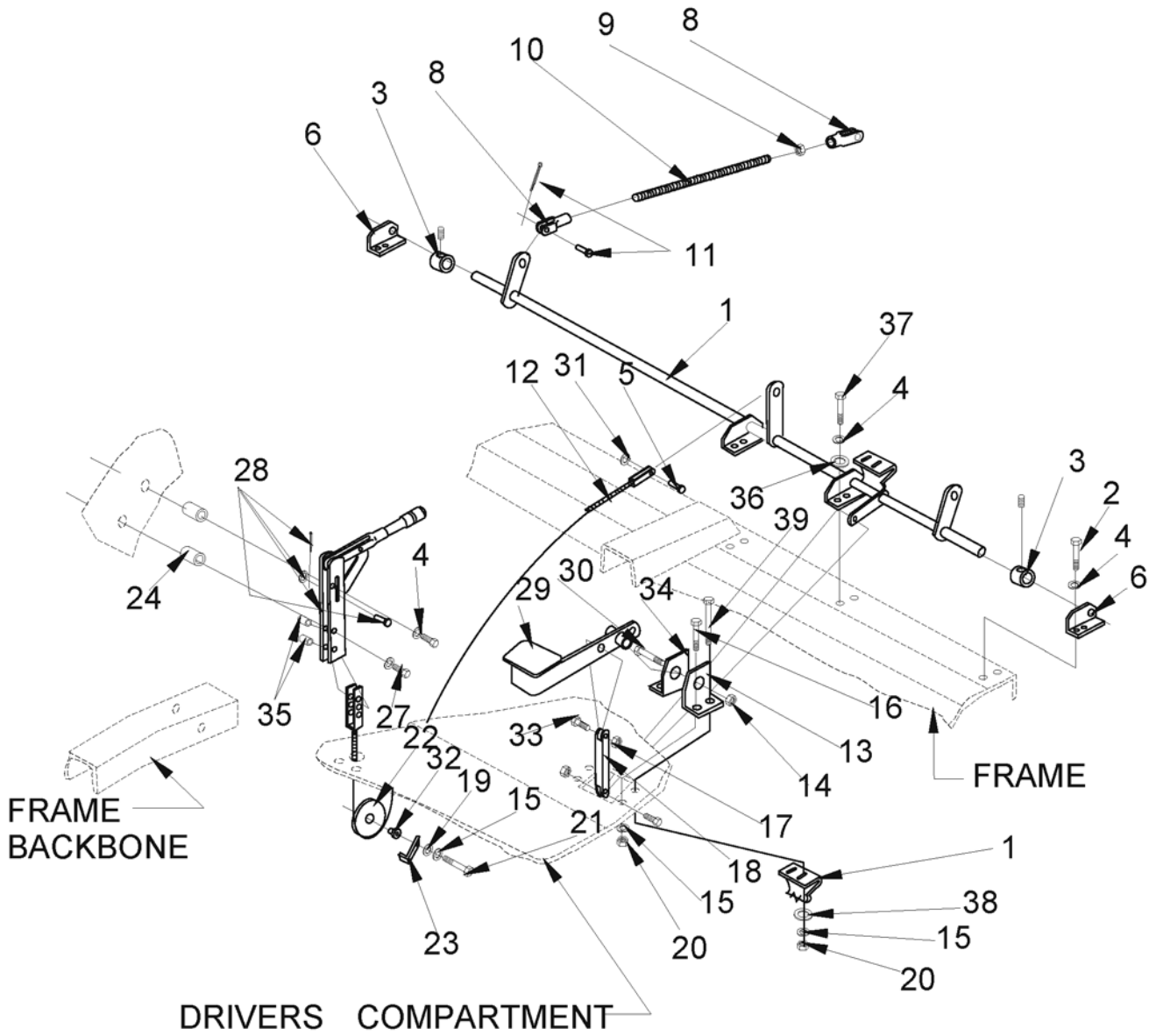

Item	Ref. No.	Qty	Description
1	8-70-05288	1	Shaft, Brake Pedal Pivot
2	2-00-00213	8	Screw, 5/16-18 x .625 HHC
3	8-15-01003	2	Setscrew Collar, 1.125 x .750 x .562
4	2-00-00530	10	Lock Washer, Helical Spring 5/16 Med
5	2-00-00206	1	Screw, 5/16-18 x 3/4 HHC
6	8-08-00571	2	Pivot Shaft Bracket
7	2-00-00518	1	Lock Washer, 1/4 Helical Spring
8	8-14-01006	4	Clevis
9	2-95-01999	2	Nut, 1/4-28 x .437 x .156 Hex Jam
10	8-66-00154	2	Pull Rod
11	2-00-04909	4	Yoke Pin Assembly
12	8-10-00032	1	Parking Cable
13	56516799	1	Bracket, RH Brake Pedal
14	2-00-04936	1	Nut, 1/2-13 Fiber Insert Hex
15	2-00-02310	5	Lock Washer, 3/8 Helical Spring
16	2-00-00232	2	Screw, 3/8-16 x 3/4 HHC
17	2-95-04182	2	Nut, 3/8-16 Fiber Insert Hex
18	56516797	1	Brake Linkage Weldment
19	2-00-00402	1	Flat Washer, .750 x .390 x .093
20	2-00-02360	4	Nut, 3/8-16 x .562 x .328 Hex
21	2-00-00234	1	Screw, 3/8-16 x 1.50 HHC
22	8-60-00140	1	Pulley
23	56516798	1	Bracket, Pulley
24	8-75-01184	2	Spacer, Lever Mounting
27	2-00-00228	2	Screw, 5/16-18 x 2.50 HHC
28	7-41-05083	1	Lever, Parking Brake
29	56516796	1	Pedal, Brake
30	2-00-02682	1	Screw, 1/2-13 x 2.75 HHC
31	2-00-00644	1	Nut, 5/16-18 Fiber Lock
32	8-09-01065	1	Bushing, Pulley
33	2-00-00233	2	Screw, 3/8-16 x 1.0 HHC
34	56516800	1	Bracket, LH Brake Pedal
35	7-75-01126	2	Spacer, .500 x .327 x .780 (Part of #28)
36	2-00-00409	2	Flat Washer, .687 x .343 x .0625
37	2-00-01255	2	Screw, 5/16-18 x .875 HHC
38	2-00-04801	2	Flat Washer, .875 x .390 x .093
39	2-00-00209		Screw, 3/8-16 x 1.25 HHC

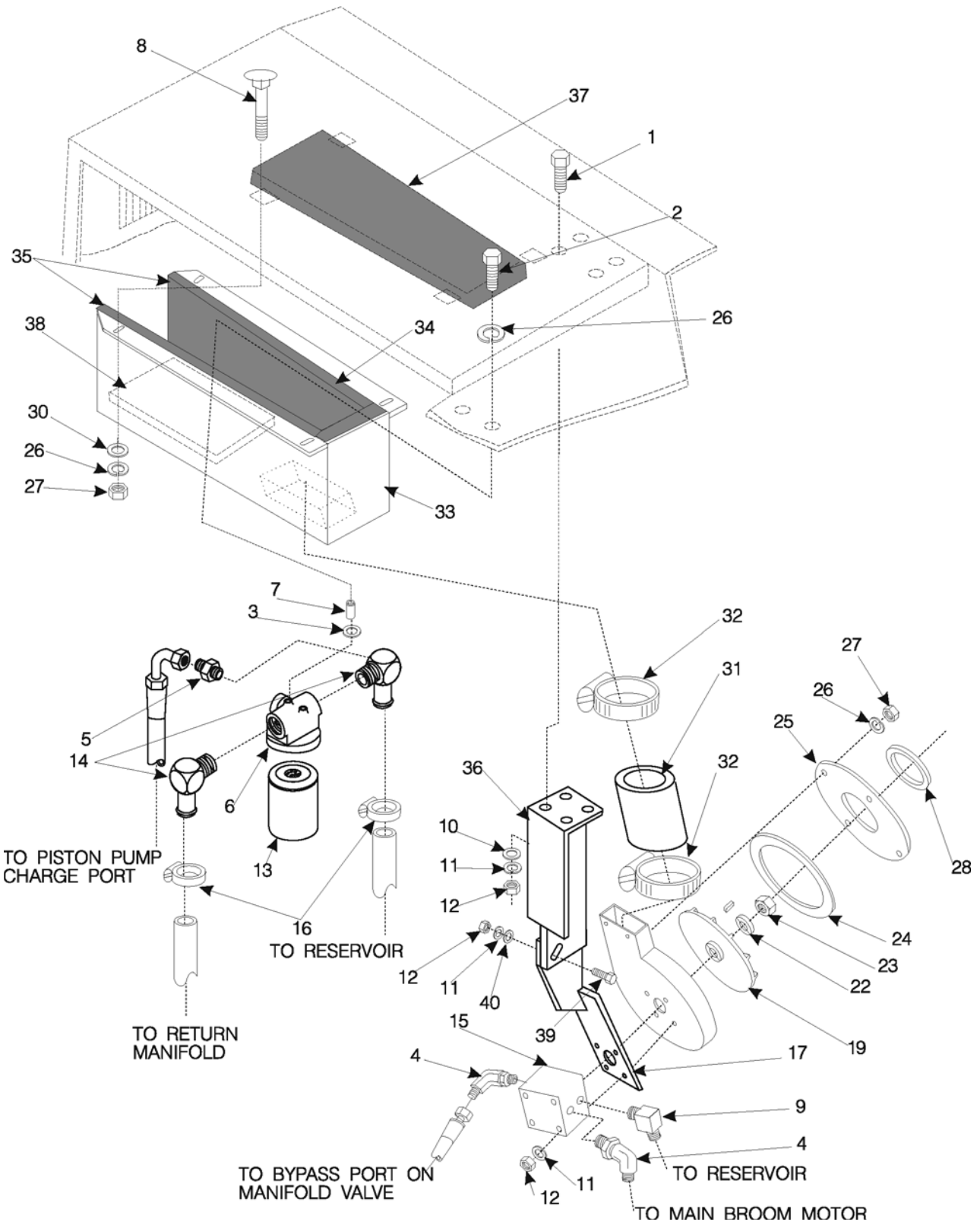

Item	Ref. No.	Qty	Description
1	2-00-02708	4	Screw, 5/16-18 x 1.0 HHM
2	8-56-05077	1	Fitting, Special 90° Elbow
3	2-00-01676	2	Flat Washer, 1.062 x .265 x .062
4	2-00-04885	1	Fitting, ORFS 90° Elbow, (Modified)
5	2-00-04997	1	Fitting, ORFS 1/4 NPT - #4 ORS
6	8-24-04133	1	Return Filter
7	8-75-01181	2	Spacer
8	2-00-03575	4	Carriage Bolt, 1/4-20 x .750
9	2-00-04976	1	Fitting
10	2-00-00409	10	Flat Washer, .687 x .343 x .062
11	2-00-00530	10	Lock Washer, Helical Spring 5/16 Med
12	2-00-00585	10	Nut, 5/16-18 x .50 x .265 Hex
13	8-24-04118	1	Replacement Filter Element
14	2-00-05133	4	Elbow
15	0882-041	1	Hydraulic Motor
	7-70-00020	1	Seal Kit for Hydraulic Motor 0882-041
	2-00-02227	1	Key, .125 x .750 SQ
16	2-00-02220	2	Clamp, Hose
17	56516801	1	Bracket, Lower Impeller
18	56516803	1	Shroud, Impeller
19	8-23-00012	1	Impeller
20	2-00-00252	4	Screw, 5/16-18 x 4.0 HHC
22	2-00-00484	1	Flat Washer, .625 x .375 x .046
23	2-00-00632	1	Nut, 3/8-24 Fiber Insert Hex
24	8-29-00111	1	Gasket, Shroud
25	56516802	1	Duct, Blower Throat
26	2-00-00518	9	Lock Washer, 1/4 Helical Spring
27	2-00-00594	8	Nut, 1/4-20 x .437 x .218 Hex
28	8-29-00183	1	Gasket
30	2-00-03702	11	Flat Washer, .625 x .281 x .062
31	8-33-02271	1	Hose, Blower Exhaust
32	2-00-03454	2	Band Clamp 5 1/8-6
33	56516805	1	Duct, Blower Exhaust Box
34	8-34-09009	1	Insulation, Side
35	8-34-09007	2	Insulation, Front
36	56516804	1	Bracket, Upper Impeller
37	8-34-09006	1	Insulation, Blower Box (Top)
38	8-34-09005	1	Insulation, Blower Box (Bottom)
39	2-00-00196	2	Carriage Bolt, 5/16-18 x 1.0
40	2-00-01803	2	Flat Washer, 5/16

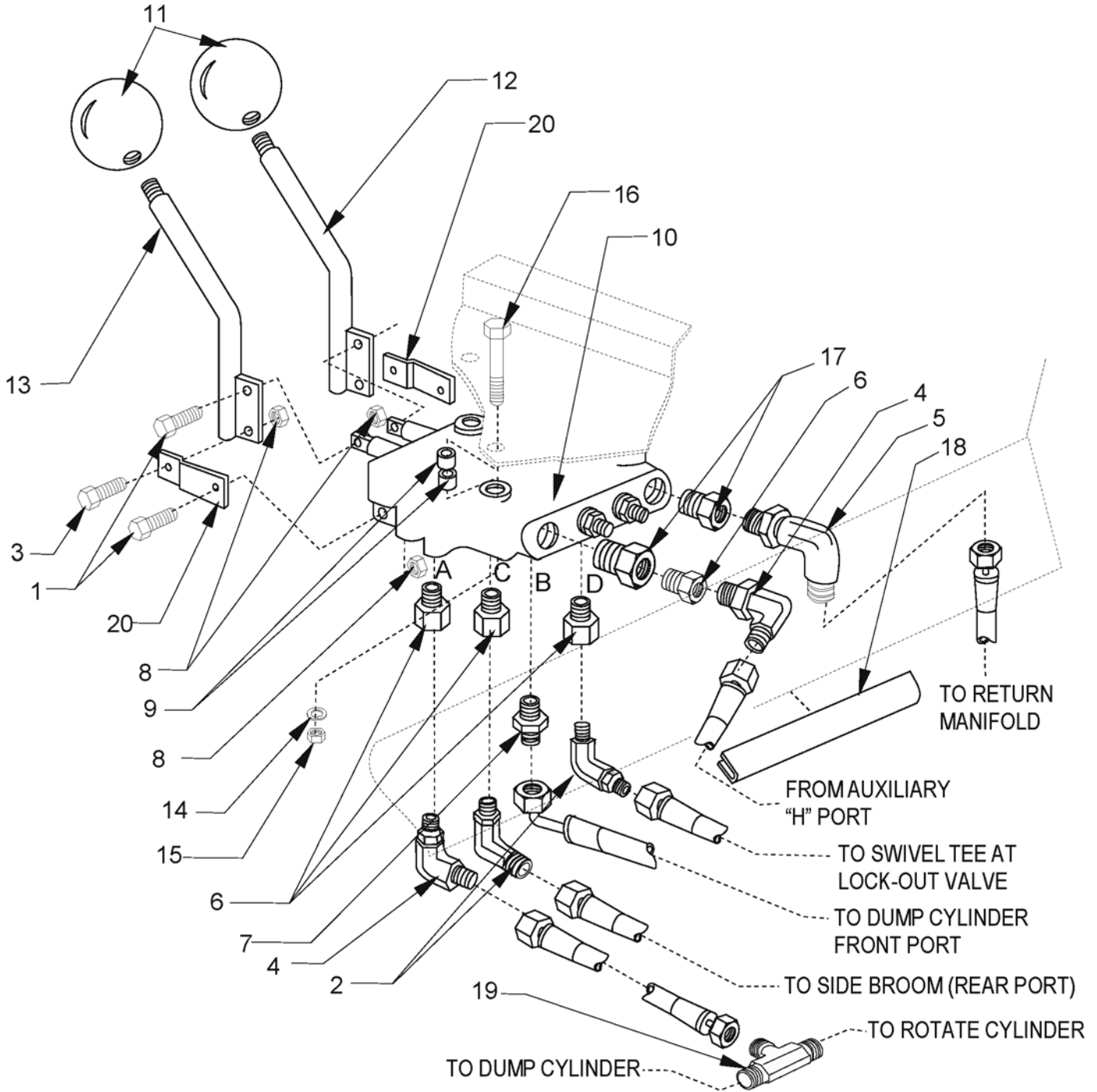

Item	Ref. No.	Qty	Description
1	2-00-04795	4	Screw, #10-24 x .750 BLTS
2	2-00-04976	2	45° Elbow, #4 SAE to #4 ORS
3	2-00-05162	1	Swivel Tee, #4 ORS
4	2-00-04892	2	ORFS 90° Elbow, #4 SAE to #4 ORS
5	2-00-04926	1	90° Elbow, #6 SAE to #4 ORS
6	2-00-04917	5	ORFS Boss Reducer, #6 SAE to #4 SAE
7	2-00-04918	2	ORFS Connector, #6 SAE to #4 ORS
8	2-00-01246	6	Nut, Hex Fiber Insert #10-24
9	8-15-01008	4	Spacer
10	8-88-00058	1	Hopper Control Valve
11	8-39-00002	2	Valve Lever Knob
12	8-41-05066	1	Control Valve Lever (L.H.)
13	8-41-05068	1	Control Valve Lever (R.H.)
14	2-00-00518	2	Lock Washer, Helical Spring 1/4 Med
15	2-00-00594	2	Nut, Hex 1/4 - 20 x .437 x .218
16	2-00-01980	2	Screw, 1/4-20 x 2.500 HHC
17	2-00-04932	2	Reducer, #8 SAE - #6 SAE
18	7-21-04031	1	Edging
19	2-00-04930	1	Fitting, Tee
20	8-41-05067	2	Linkage

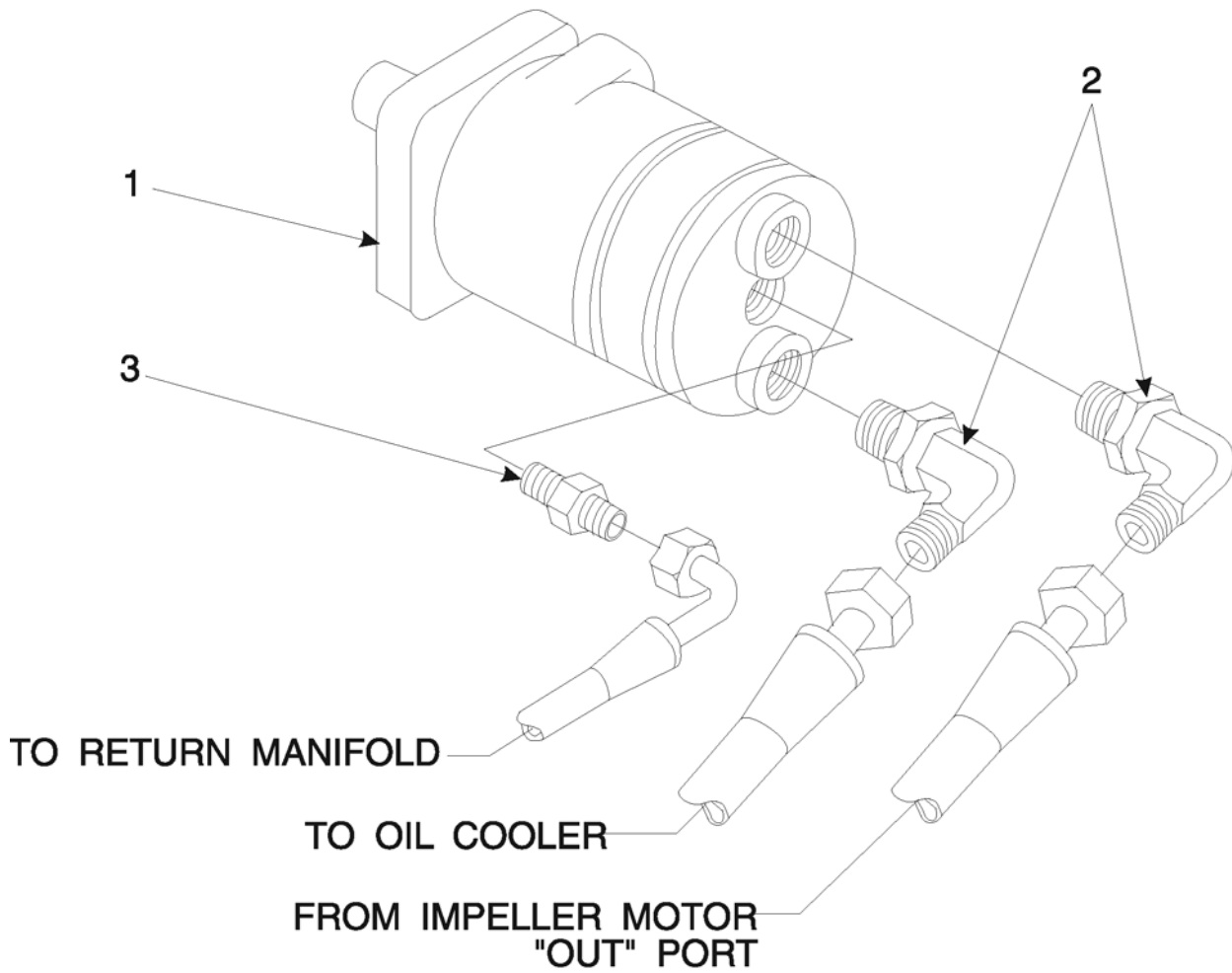

09-5	MAIN BROOM MOTOR & FITTINGS		
10-1	Granterra		41

Item	Ref. No.	Qty	Description
1	0882-040	1	Hydraulic Motor
NS	56479577	1	Motor Seal Kit
2	2-00-04885	2	ORFS 90° Elbow, 3/4-16 to 13/16-16
3	2-00-04895	1	ORFS Connector, 7/16-20 to 9/16-18

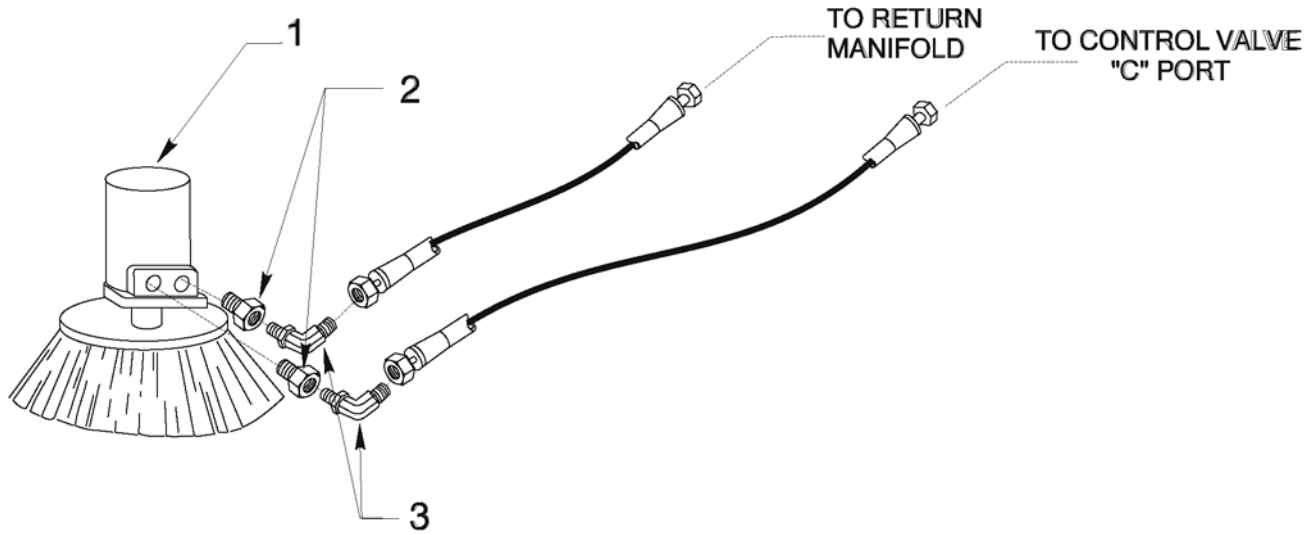

Item	Ref. No.	Qty	Description
1	0882-047	1	Hydraulic Motor
NS	56479577	1	Motor Seal Kit
2	2-00-04915	2	ORFS Boss Reducer, 7/8-14 to 9/16-18
3	2-00-04926	4	ORFS 90° Elbow, 9/16-18
4	0891-008	1	Side Broom Shut-Off Valve
5	2-00-04940	2	ORFS Swivel Nut Branch Tee, #4 ORS
6	7-12-02015	1	Cartridge for Shut-Off Valve

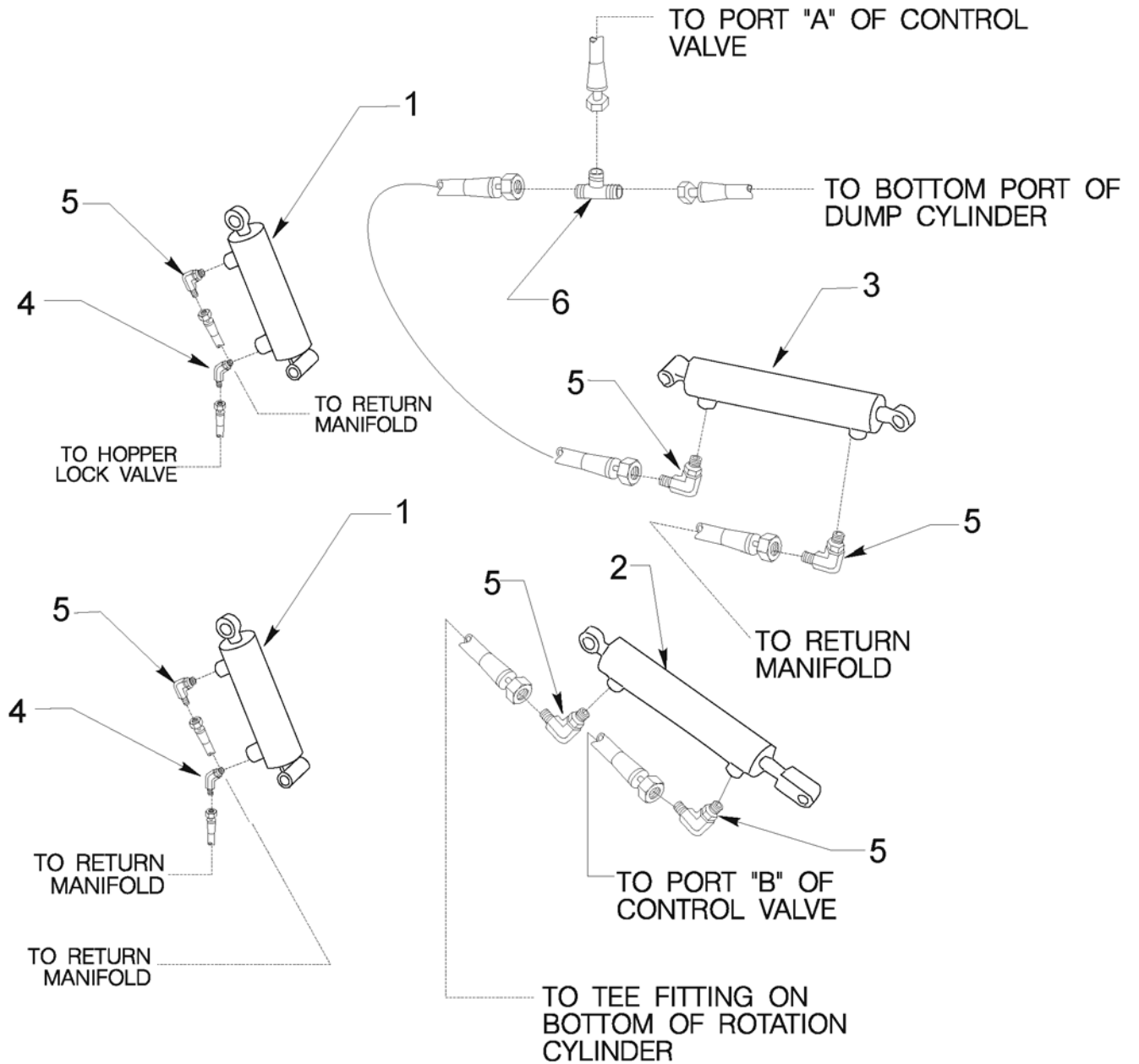

Item	Ref. No.	Qty	Description
1	8-17-05029	2	Lift Cylinder
2	8-17-05028	1	Dump Cylinder
3	8-17-05030	1	Rotation Cylinder
4	2-00-04976	2	ORFS Connector, 7/16-20 to 9/16-18
5	2-00-04892	6	ORFS 90° Elbow, 7/16-20 to 9/16-18
6	2-00-04930	2	ORFS Union Tee, 9/16-18
NS	0880-449	1	Lift Cylinder Seal Kit
NS	0880-505	1	Dump Cylinder Seal Kit
NS	0880-450	1	Rotation Cylinder Seal Kit

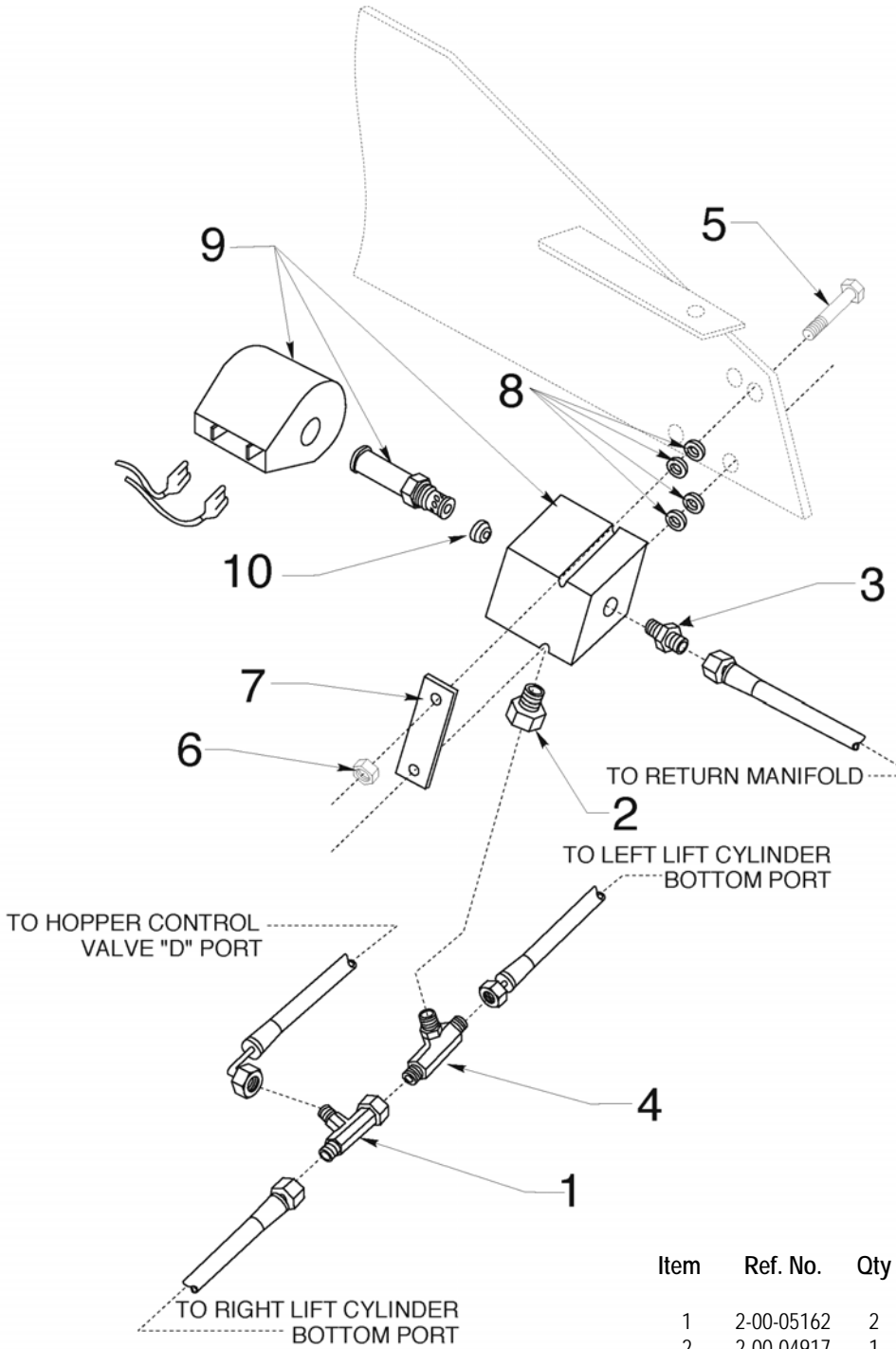

Item	Ref. No.	Qty	Description
1	2-00-05162	2	Tee, Swivel #4 ORS
2	2-00-04917	1	ORFS Boss Reducer, 9/16-18 to 7/16-20
3	2-00-04918	1	ORFS Connector, 7/16-18 to 9/16-18
4	2-00-04919	1	ORFS Branch Tee, 7/16-20 x (2) 9/16-18
5	2-00-02589	4	Screw, 1/4 - 20 x 2.000 HHC
6	2-00-00641	2	Nut, Hex Fiber Insert 1/4 - 20
7	8-08-00590	1	Bracket
8	2-00-03702	4	Flat Washer, .625 x .281 x .0625
9	8-88-00044	1	Hopper Lock Valve
10	8-88-00056	1	Orifice Disc

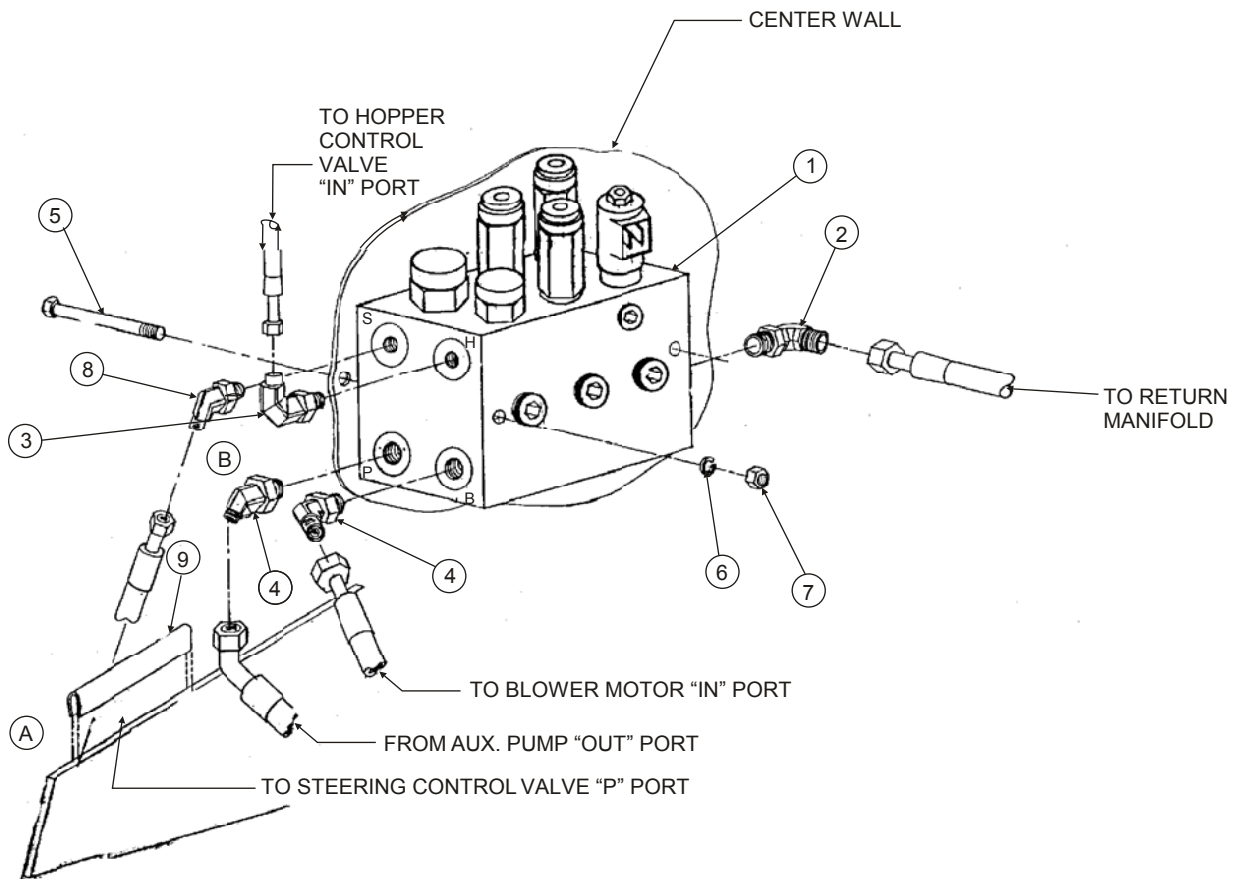

Item	Ref. No.	Qty	Description
1	8-88-00055	1	Auxiliary Manifold
	7-14-07004	1	Coil
2	2-00-04885	1	ORFS 90° Elbow, 3/4-16 / 13/16-16
3	2-00-04892	1	ORFS 90° Elbow, 7/16-20 / 9/16-18
4	2-00-04975	1	Fitting
5	2-00-04596	1	ORFS Nut, 13/16-16
6	2-00-00518	2	Lock Washer, Helical Spring 1/4 Med
7	2-00-00594	2	Nut, Hex 1/4 - 20
8	2-00-04976	1	Elbow 45° #4 SAE - ORS

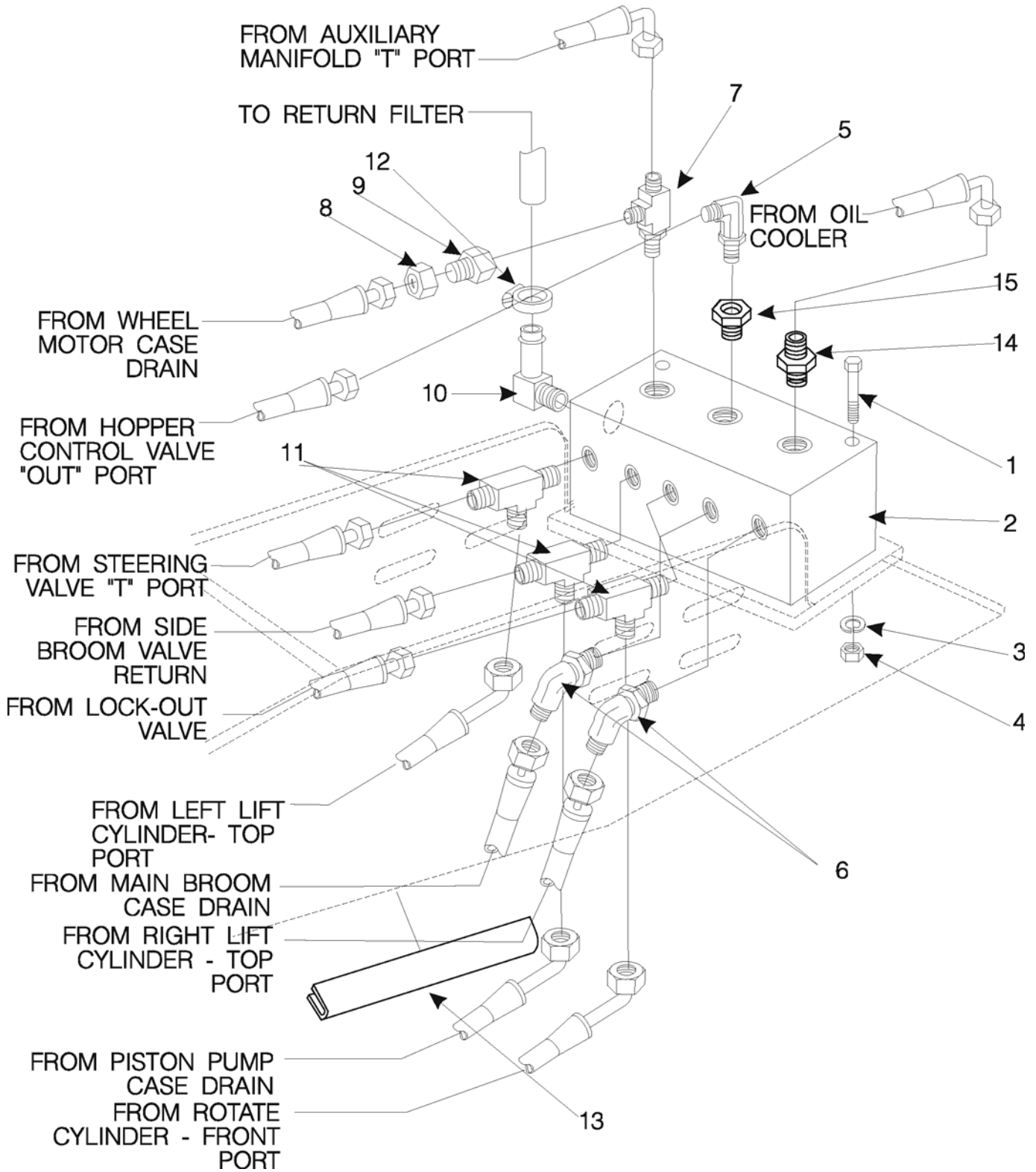

Item	Ref. No.	Qty	Description
1	2-00-04596	2	Screw, 1/4 - 20 x 3.50
2	7-48-00019	1	Return Manifold
3	2-00-00518	2	Lock Washer, Helical Spring 1/4 Med
4	2-00-00594	2	Nut, Hex 1/4 - 20 x .437 x .218
5	2-00-04926	3	ORFS 90° Elbow, 7/16-20 to 9/16-18
6	2-00-04976	3	45° Elbow, O-ring
7	2-00-04924	1	Swivel Tee
8	2-00-04939	1	Nut for Reducer Fitting
9	2-00-04929	2	Fitting, Reducer
10	2-00-05133	1	90° Elbow
11	2-00-04927	2	Run Tee, O-ring
12	2-00-02220	1	Clamp
13	7-21-04031	2	Edging
14	2-00-04970	2	Fitting, Straight #8 SAE - #8 ORS
15	2-00-04932	1	Fitting, Reducer #8 - #6 SAE

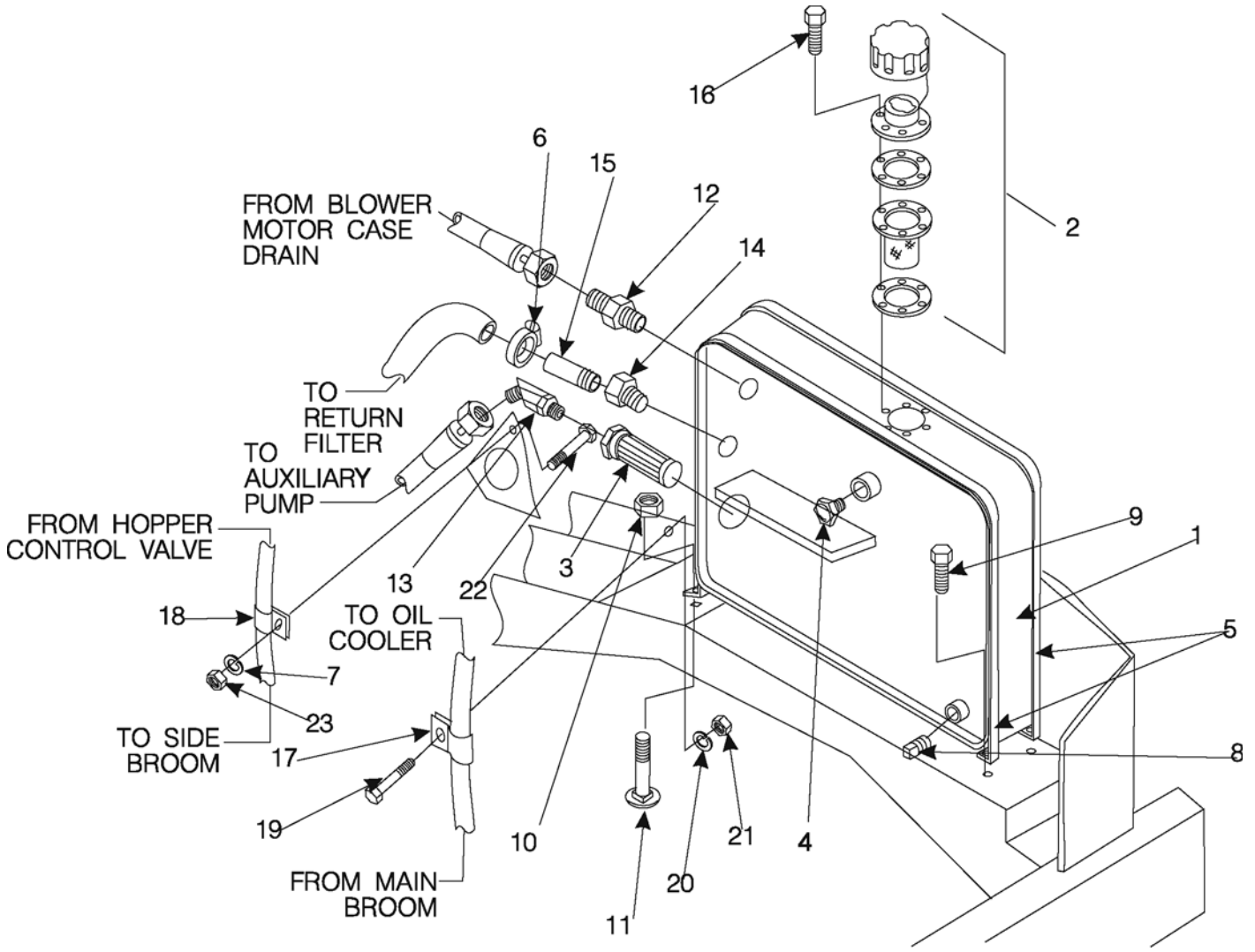

09-5	HYDRAULIC RESERVOIR & FITTINGS		
09-10	Granterra		49

Item	Ref. No.	Qty	Description
1	8-83-04036	1	Hydraulic Reservoir
2	8-11-00026	1	Filler Cap Assembly
3	8-24-04115	1	Strainer
4	8-48-05033	1	Sight Glass
5	8-79-00114	2	Strap
6	2-00-02220	3	Hose Clamp, .812 - 1.500
7	2-00-00518	5	Lock Washer, 1/4
8	2-00-02474	1	Pipe Plug, 1/2 NPT
9	2-00-00205	4	Screw, 1/4 - 20 x 1.000 HHC
10	2-00-00641	2	Nut, 1/4-20 Fiber Lock
11	2-00-02196	4	Carriage Bolt, 1/4 - 20 x 1.000
12	2-00-04895	1	Fitting Strt, #4 SAE - #4 ORS
13	2-00-05037	1	Adapter, 3/4 ORS x 3/4 NPT 45° Elbow
14	2-00-04572	1	Reducer, #12 Ste - 3/4 NPT
15	2-00-03585	1	Pipe Nipple, 3/4 NPT
16	2-00-03940	6	Screw, #10-24 x .500 T/C HH
17	2-00-04564	1	Hose Clamp, 13/16
18	2-00-04873	1	Clamp
19	2-00-02708	1	Screw, 5/16-18 x 1.000 HHC
20	2-00-00530	1	Lock Washer, 5/16
21	2-00-00585	2	Nut, Hex 5/16-18
22	2-00-02196	2	Carriage Bolt, 1/4-20 x 1.000
[]	56501067	1	Hydraulic Oil (8.8 Gal.)

[] = Not Shown

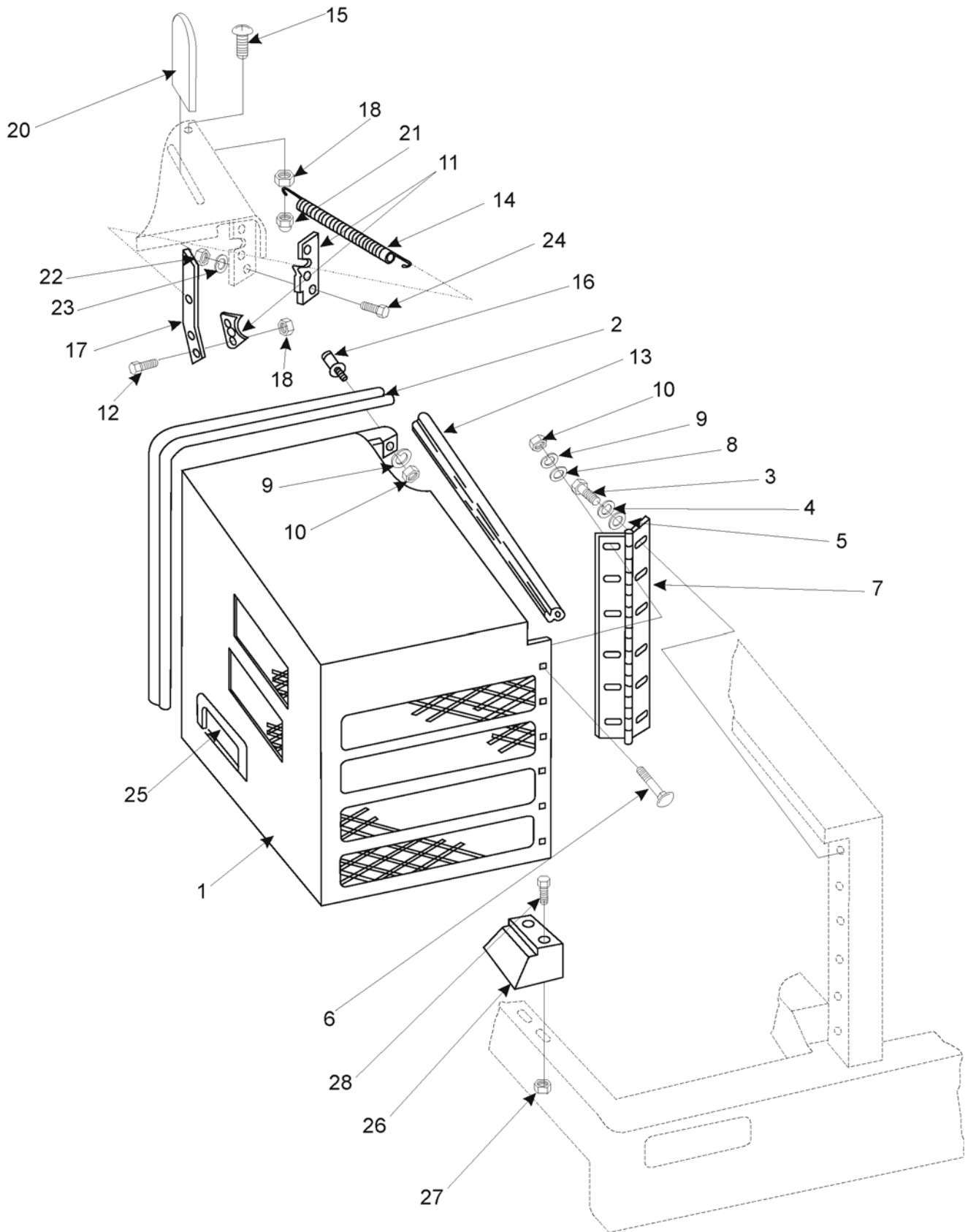

Item	Ref. No.	Qty	Description
1	56516812	1	Engine Cover Weldment
2	8-21-04043	1	Edging, Engine Compartment Seal
3	2-00-00233	6	Screw, 3/8 - 16 x 1.00 HHC
4	2-00-02310	6	Lock Washer, Helical Spring 3/8 Med
5	2-00-04801	6	Flat Washer, .875 x .375 x .062
6	2-00-03569	6	Carriage Bolt, 5/16-18 x .750
7	56516813	1	Engine Cover Hinge
8	2-00-00409	6	Flat Washer, 5/16 x .69
9	2-00-00530	7	Lock Washer, Helical Spring 5/16
10	2-00-00585	7	Nut, Hex 5/16-18
11	8-41-00046	1	Rotary Latch
12	2-00-04794	2	Screw, #10-24 x .625 BHS
13	8-21-04042	1	Edging, Engine Compartment Seal
14	7-76-00106	1	Lever Return Spring
15	2-00-03063	1	Screw, #10-24 x .750 THM
16	7-55-08116	1	Striker Latch Pin
17	56516815	1	Latch Release Lever
18	2-00-01246	3	Insert, #10 - 24 Thin Nylon
20	7-31-06061	1	Lever Cover
21	2-00-01246	1	Nut, Hex Fibre Lock #10-24
22	2-00-00594	3	Nut, Hex 1/4-20
23	2-00-00518	3	Lock Washer, Helical Spring 1/4
24	2-00-02587	3	Screw, 1/4-20 x 1.250 HHC
25	8-21-04038	1	Hand Hole Edging
26	7-78-05016	1	Engine Cover Stop
27	2-00-00641	2	Nut, Hex Fiber Lock 1/4-20
28	2-00-01769	2	Screw, 1/4-20 x 1.75 HHC

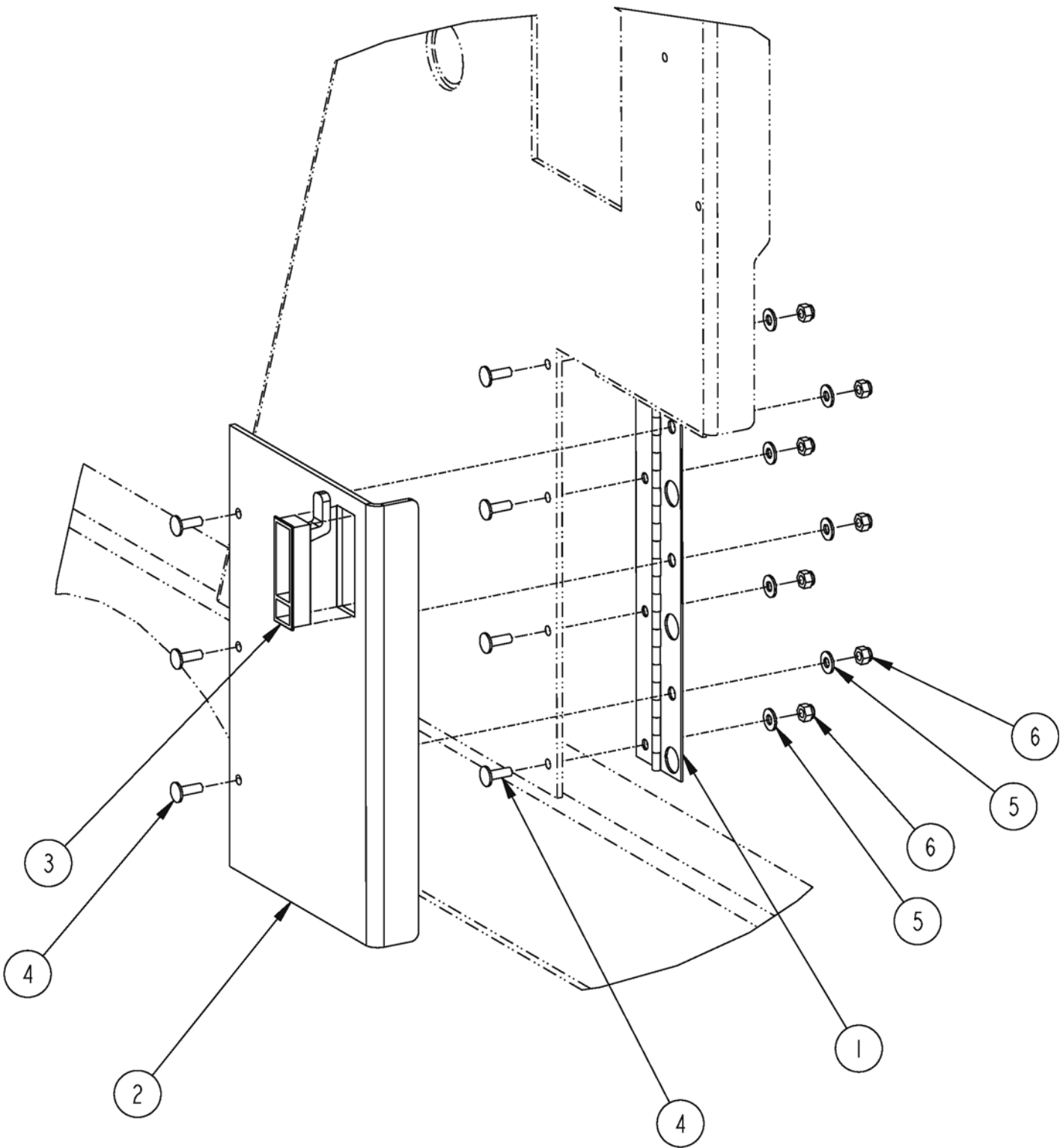

09-5

ENGINE ACCESS DOOR

Granterra

53

Item	Ref. No.	Qty	Description
1	7-89-06545	1	Hinge
2	56516831	1	Door, Lintel
3	8-41-00044	1	Latch
4	2-00-00183	7	Screw, 1/4-20 x 3/4 Round Head
5	2-00-03702	7	Washer, .625 x .281 x .063
6	2-00-00641	7	Nut, 1/4-20 Fiber Insert

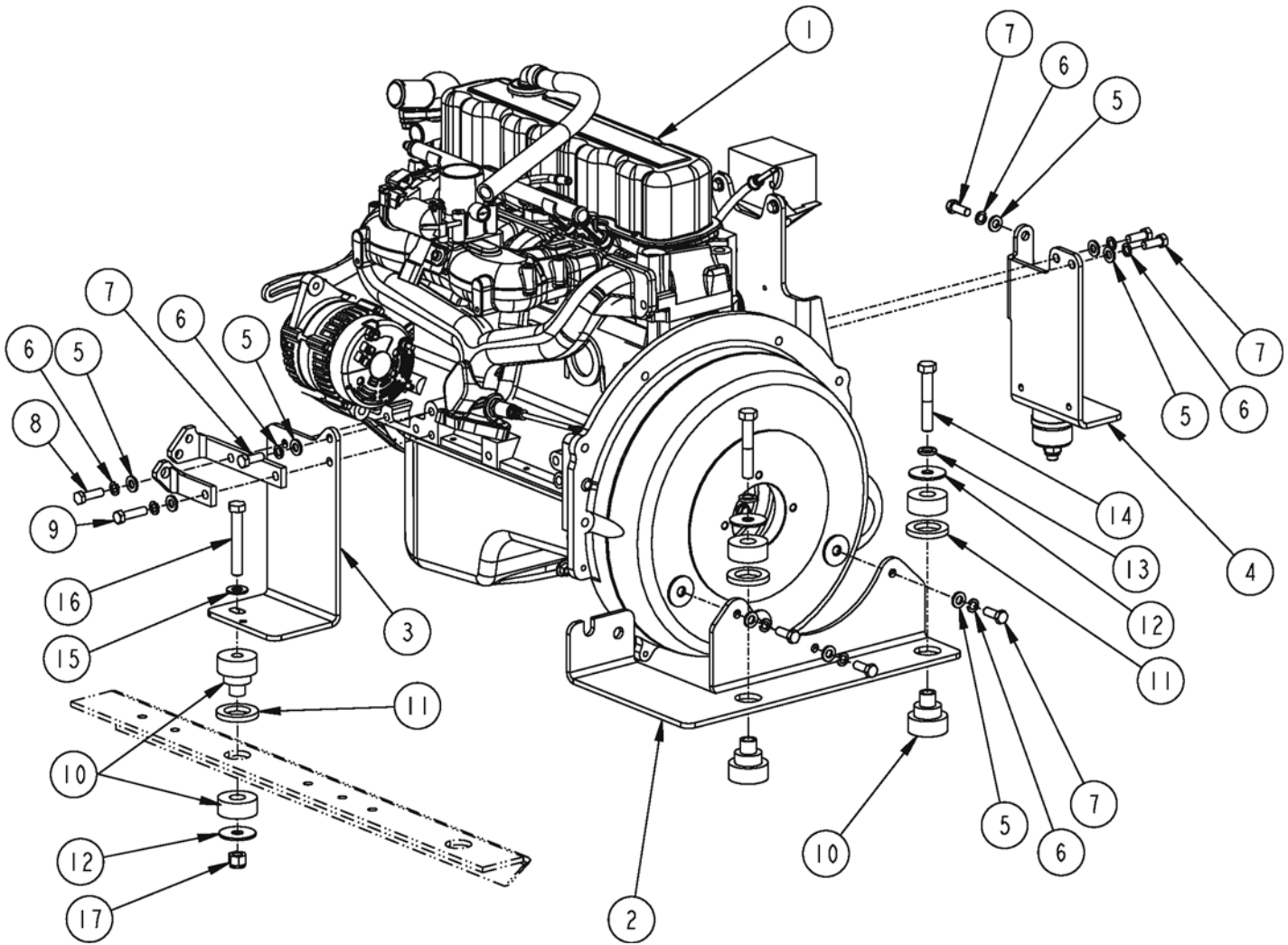

Item	Ref. No.	Qty	Description
1#	0777-068	1	Engine, GM 3.0 LPG (IMPCO)
#	0777-069	1	Engine, GM 3.0 GASOLINE / PETROL (IMPCO)
*	56504513	A/R	Engine-Long Block Assy-3.0L
2	8-08-00966	1	Bracket, Engine Mount
3	8-08-00967	1	Bracket, Engine Mount
4	8-08-00968	1	Bracket, Engine Mount
5	2-00-00402	9	Washer, 25/64 ID x 3/4 OD
6	2-00-02310	9	Lock Washer, 3/8 Helical Spring
7	2-00-00233	7	Bolt, 3/8-16 x 1.25 Fin. Hex Head
8	2-00-00209	1	Bolt, 3/8-16 x 1.25 Hex Head
9	2-00-00234	1	Screw, 3/8-16 x 1.50 HHC
10	7-35-00017	4	Isolator, Engine Mount (Red Dot)
11	2-00-05955	4	Washer
12	2-00-05067	4	Spacer, Snubbing Washer
13	2-00-02312	2	Lock Washer, 1/2"
14	2-00-02697	2	Screw, 1/2-20 x 3.0
15	2-00-00405	2	Flat Washer, 1.063 x .531 x .094
16	2-00-02617	2	Screw, 1/2-13 x 3.5 SS
17	2-00-04936	2	Nut, 1/2-13 Elastic Lock

Item	Ref. No.	Qty	Description	Item	Ref. No.	Qty	Description
			Engine Replacement Parts				Engine Replacement Parts
*	56109000	1	Ecu, 06 Lp Cert 3.0l NOTE 1	*	56109024	1	PCV Valve
*	56109001	1	Ecu, 06 Gas Cert 3.0l NOTE 2	*	56109025	1	Starter
*	56109113	1	Ecu, 07 Lp Cert 3.0l NOTE 1	*	56109026	2	Bolt, Starter
*	56109114	1	Ecu, 07 Gas Cert 3.0l NOTE 2	*	56305867	1	Alternator
*	0795-225	1	Harness, 3.0l Lp Engine NOTE 1	*	56109028	1	Belt, Alternator
*	0795-228	1	Harness, 3.0l Gas Engine NOTE 2	*	56109029	1	Thermostat
*	0795-220	1	Harness: Engine - Machine Patch	*	56109030	1	Gasket, Thermostat
*	56109002	1	Sensor, Coolant	*	56109032	1	Gasket, Thermostat Housing
*	56109003	1	Sensor, Crankshaft Position	*	56109033	1	Throttle Body, Bosch 40mm
*	56305405	1	Sensor, Tmap	*	56109034	1	Gasket, Throttle Body
*	56109005	1	Sensor, O2 Pre Cat	*	56109035	1	Mixer, Impco Model 100 NOTE 1
*	56109006	1	Switch, Oil Pressure	*	56109036	1	Gasket, Adapter - Mixer NOTE 1
*	8-69-00013	1	Sender, Water Temp	*	56109040	1	Adapter, Mixer - Throttle Body NOTE 1
*	8-69-00005	1	Sender, Oil Pressure	*	56109041	2	Seal, Mixer Adapter NOTE 1
*	56109007	1	Water Pump	*	56109042	1	O-Ring, Mixer Adapter NOTE 1
*	56109008	1	Oil Pump	*	56109043	1	Electronic Pressure Regulator (EPR) NOTE 1
*	56109009	1	Gasket, Cylinder Head	*	56504540	1	Bracket-EPR Mounting NOTE 1
*	56109010	1	Gasket, Valve Cover	*	56109044	1	Sender, LPG Temp - EPR NOTE 1
*	56109011	1	Gasket, Lifter Cover	*	56109045	1	Fitting Kit, EPR NOTE 1
*	56109012	1	Gasket, Intake Manifold	*	56109046	3	Isolator, EPR NOTE 1
*	56109013	1	Plate, Drive, Sae 13t B-B	*	56109047	1	Hose, Water - EPR NOTE 1
*	56109014	6	Bolt, Drive Plate	*	7-88-00110	1	Valve, Lp Safety NOTE 1
*	56109015	1	Distributor Assembly	*	56109048	1	Connector, Safety Valve NOTE 1
*	56109016	1	Distributor Cap	*#	56109049	1	Lock, Safety Valve Connector NOTE 1, NOTE 3
*	56109017	1	Distributor Rotor	*#	56305410	1	Filter, Propane NOTE 1, NOTE 3
*	56109018	1	Ignition Module	*#	56508936	1	Valve-Fuel-Lockoff NOTE 1, NOTE 4
*	56109019	1	Ignition Coil	*#	56508939	1	LPG Filter Cartridge NOTE 1, NOTE 4
*	56109020	1	Coil Wire	*	56109050	1	Fuel Rail Assy NOTE 2
*	56109021	1	Spark Plug Wire Set	*	56109051	1	Fuel Injector NOTE 2
*	56109022	4	Spark Plug	*	56109185	1	Intake Manifold
*	56109023	1	Oil Filter	*	56109186	1	Exhaust Manifold
*	56504509	1	Gasket-Oil Pan	*	56504459	1	Front Crankshaft Seal
				*	56504475	1	Hose-Breather Cap
				*	56504476	1	Sender-Water Temp
				*	56504474	1	Cap-Oil Fill
				*	56504541	1	Fitting-2 In. Pipe Nipple NOTE 1
				*	56109084	A/R	Engine Service Kit

* = Not Shown

= Revised or new since last update

NOTE 1: LPG models only**NOTE 2:** Gasoline / Petrol models only**NOTE 3:** Used on machines up to Serial No. 1000036509.**NOTE 4:** Used on machines Serial No. 1000036509 and above.

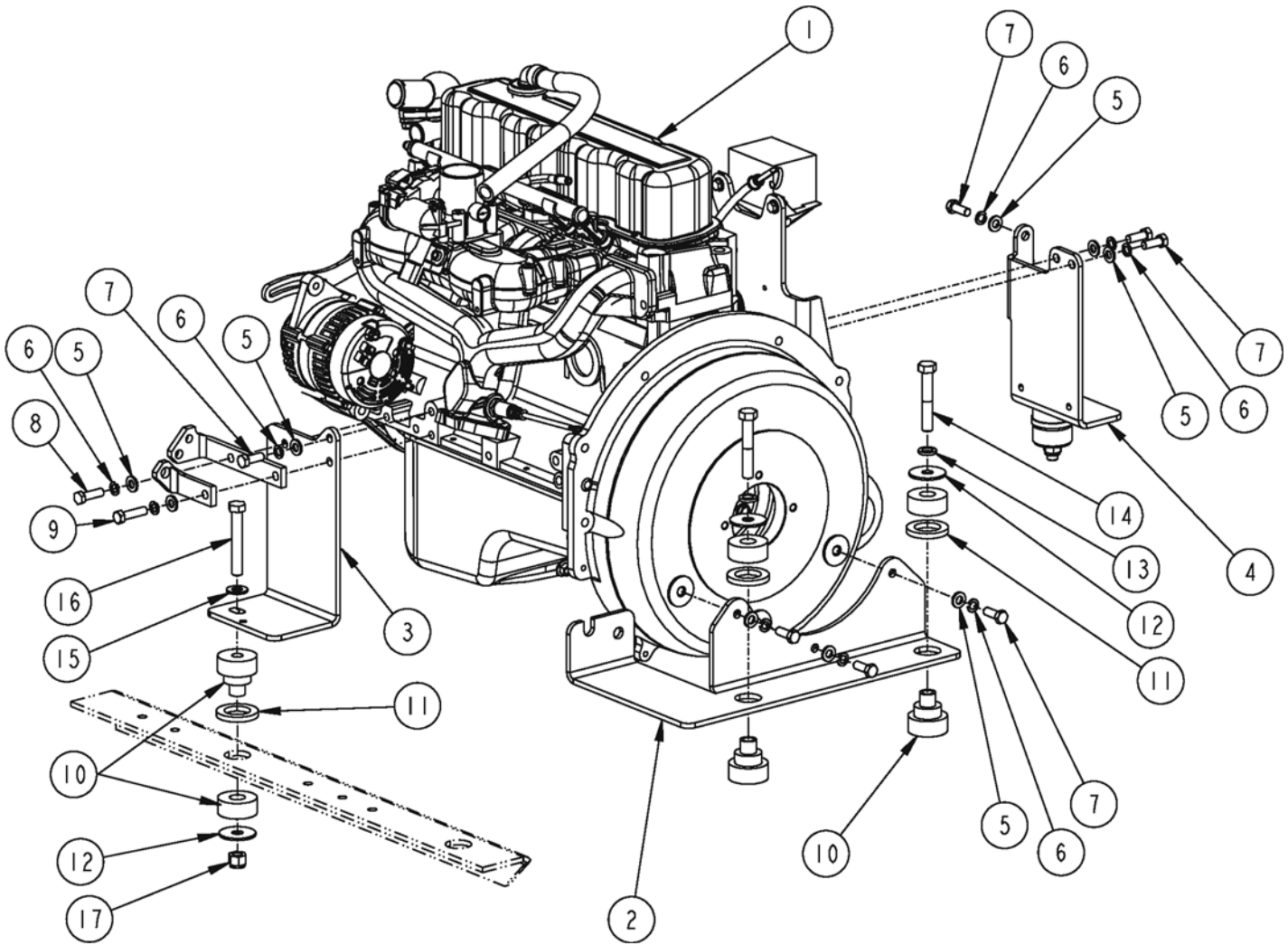

Item	Ref. No.	Qty	Description
1#	56380126	1	Engine-PSI, GM 3.0 LP (PSI)
#	56380127	1	Engine-PSI, GM 3.0 GAS (PSI)
*#	56504513	A/R	Engine-Long Block Assy-3.0L
2#	8-08-00966	1	Bracket, Engine Mount
3#	8-08-00967	1	Bracket, Engine Mount
4#	8-08-00968	1	Bracket, Engine Mount
5#	2-00-00402	9	Washer, 25/64 ID x 3/4 OD
6#	2-00-02310	9	Lock Washer, 3/8 Helical Spring
7#	2-00-00233	7	Bolt, 3/8-16 x 1.25 Fin. Hex Head
8#	2-00-00209	1	Bolt, 3/8-16 x 1.25 Hex Head
9#	2-00-00234	1	Screw, 3/8-16 x 1.50 HHC
10#	7-35-00017	4	Isolator, Engine Mount (Red Dot)
11#	2-00-05955	4	Washer
12#	2-00-05067	4	Spacer, Snubbing Washer
13#	2-00-02312	2	Lock Washer, 1/2"
14#	2-00-02697	2	Screw, 1/2-20 x 3.0
15#	2-00-00405	2	Flat Washer, 1.063 x .531 x .094
16#	2-00-02617	2	Screw, 1/2-13 x 3.5 SS
17#	2-00-04936	2	Nut, 1/2-13 Elastic Lock

Engine Replacement Parts

Engine 3.0L GM (PSI)			GAS/PETROL ONLY				
*#	0795-220	1	Harness: Engine - Machine Patch	*#	56380130	1	Harness-Psi 3.0l Gas
*#	56109002	1	Sensor, Coolant	*#	56109033	1	Throttle Body, Bosch 40mm
*#	56109003	1	Sensor, Crankshaft Position	*#	56109050	1	Fuel Rail Assembly
*#	56109004	1	Sensor, Tmap	*#	56109051	4	Fuel Injector
*#	7-11-04081	1	Sensor-O2	*#	56380128	1	Ecu-Psi 3.0l Gas
*#	56380238	1	Sender-3.0l Oil Pressure	*#	0795-226	1	Harness, Fuel Temp Extension
*#	8-69-00013	1	Sender, Water Temp	*#	56305062	1	Fuel Pump
*#	8-69-00005	1	Sender, Oil Pressure	*#	56109052	1	Fitting, Fuel Pump
*#	56109007	1	Water Pump	*#	56305412	1	Fuel Filter
*#	56109008	1	Oil Pump	*#	7-11-04082	1	Manifold, Fuel Temp - Return
*#	56109010	1	Gasket, Valve Cover	*#	7-11-04083	4	Fitting, -6 Stor - 5/16 Sae J2044
*#	56109011	1	Gasket, Lifter Cover	*#	7-11-04084	1	Fitting, -3 Stor - 5/16 Sae J2044
*#	56109012	1	Gasket, Intake Manifold				
*#	56109013	1	Plate, Drive, Sae 13t B-B				
*#	56109014	6	Bolt, Drive Plate	*#	56380131	1	Harness-Psi 3.0l Lp
*#	56109015	1	Distributor Assembly	*#	56380129	1	Ecu-Psi 3.0l Lp
*#	56109016	1	Distributor Cap	*#	56380136	1	Depr-Psi 3.0l
*#	56109017	1	Distributor Rotor	*#	56380138	1	Regulator-Dual Stage
*#	56109018	1	Ignition Module	*#	56109207	1	Adapter-3.0l Mixer
*#	56109019	1	Ignition Coil	*#	56111892	1	Elbow-90 Deg Reducer
*#	56109020	1	Coil Wire	*#	56380151	1	Hose-Intake
*#	56109021	1	Spark Plug Wire Set	*#	56109206	1	Body-3.0l Throttle
*#	56109022	4	Spark Plug	*#	56380145	1	Mixer-Psi 3.0l Lpg
*#	56109023	1	Oil Filter	*#	56109036	1	Gasket, Adapter - Mixer
*#	56109205	1	Valve-Pcv	*#	56109040	1	Adapter, Mixer - Throttle Body
*#	56109025	1	Starter	*#	56109041	2	Seal, Mixer Adapter
*#	56109026	2	Bolt, Starter	*#	56109042	1	O-Ring, Mixer Adapter
*#	56109027	1	Alternator, 7si	*#	56109043	1	Electronic Pressure Regulator (Epr)
*#	56109028	1	Belt, Alternator	*#	56109044	1	Sender, Lpg Temp - Epr
*#	56109029	1	Thermostat, 180°F	*#	56109045	1	Fitting Kit, Epr
*#	56109030	1	Gasket, Thermostat	*#	56109046	3	Isolator, Epr
*#	56109032	1	Gasket, Thermostat Housing	*#	56109047	1	Hose, Water - Epr
*#	56109034	1	Gasket, Throttle Body	*#	7-88-00110	1	Valve, Lp Safety
				*#	56109048	1	Connector, Safety Valve
*#	56109084	A/R	Engine Service Kit	*#	56109049	1	Lock, Safety Valve Connector
				*#	56508936	1	Valve-Fuel Lockoff
				*#	56508939	1	Cartridge-Lpg Filter
				*#	56109208	1	Manifold-3.0l Intake

* = Not Shown

= Revised or new since last update

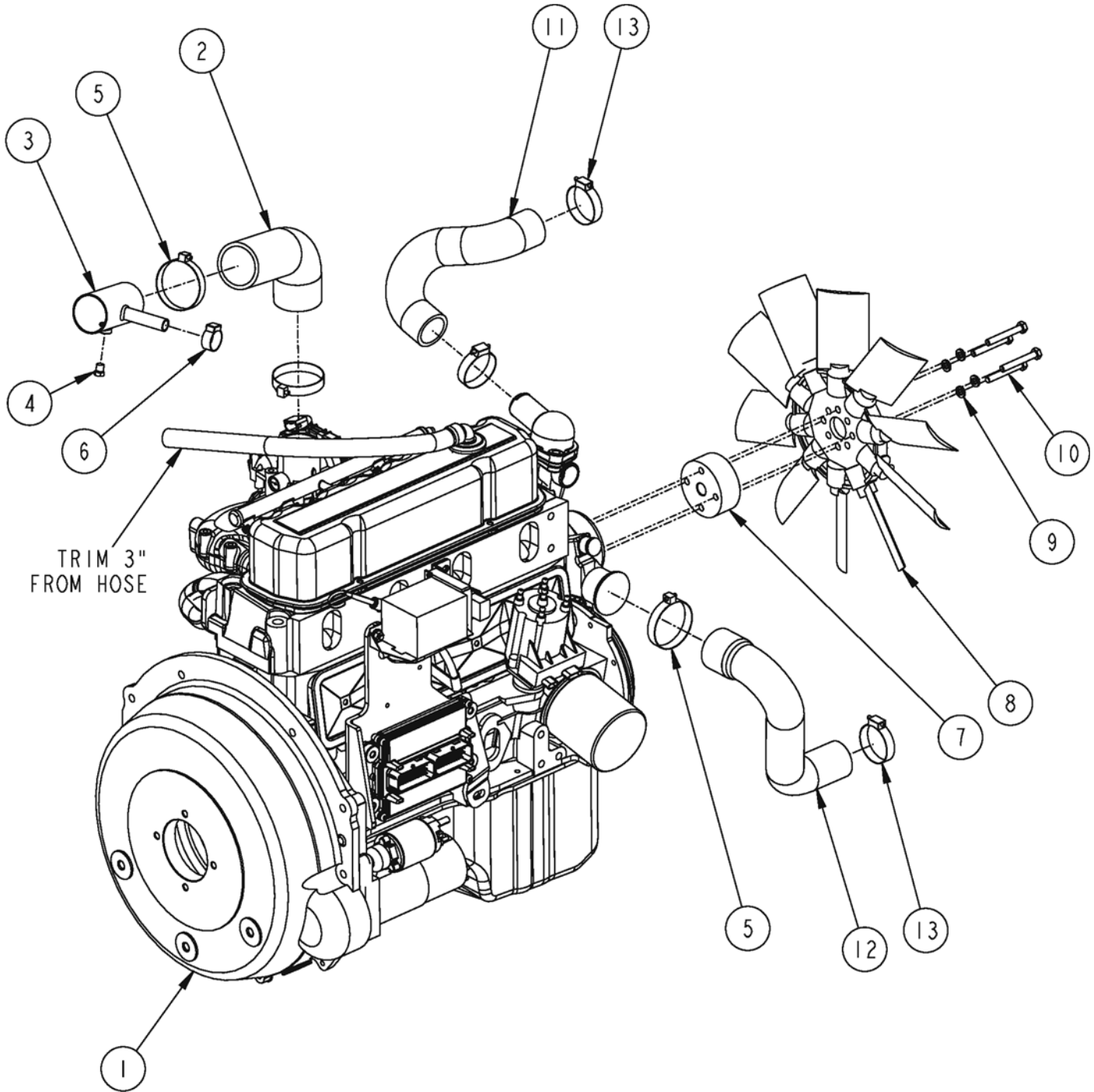

09-5	GM 3.0 LITER - GAS ENGINE (FAN, AIR INTAKE & RADIATOR HOSES)		
10-5	Granterra		59

Item	Ref. No.	Qty	Description
1#	0777-069	1	Engine, GM 3.0 GAS (IMPCO)
#	56380127	1	Engine-PSI, GM 3.0 GAS (PSI)
2	7-33-02712	1	Hose, Air Intake
3	56305240	1	Tube (Weldment)
4	2-00-03778	1	Plug, 1/8 NPT
5	2-00-02216	3	Clamp, Hose
6	2-00-03407	1	Clamp, Witteck #10P
7	7-75-01282	1	Spacer, Fan
8	8-23-00018	1	Fan, 15.5" Breeza
9	2-00-00530	4	Lock Washer, 5/16
10	2-00-06557	4	Screw, 5/16-24 x 2.25 Hex Head
11	8-33-02409	1	Hose, Upper Radiator
12	8-33-02410	1	Hose, Lower Radiator
13	2-00-03404	3	Clamp, Hose

= Revised or new since last update

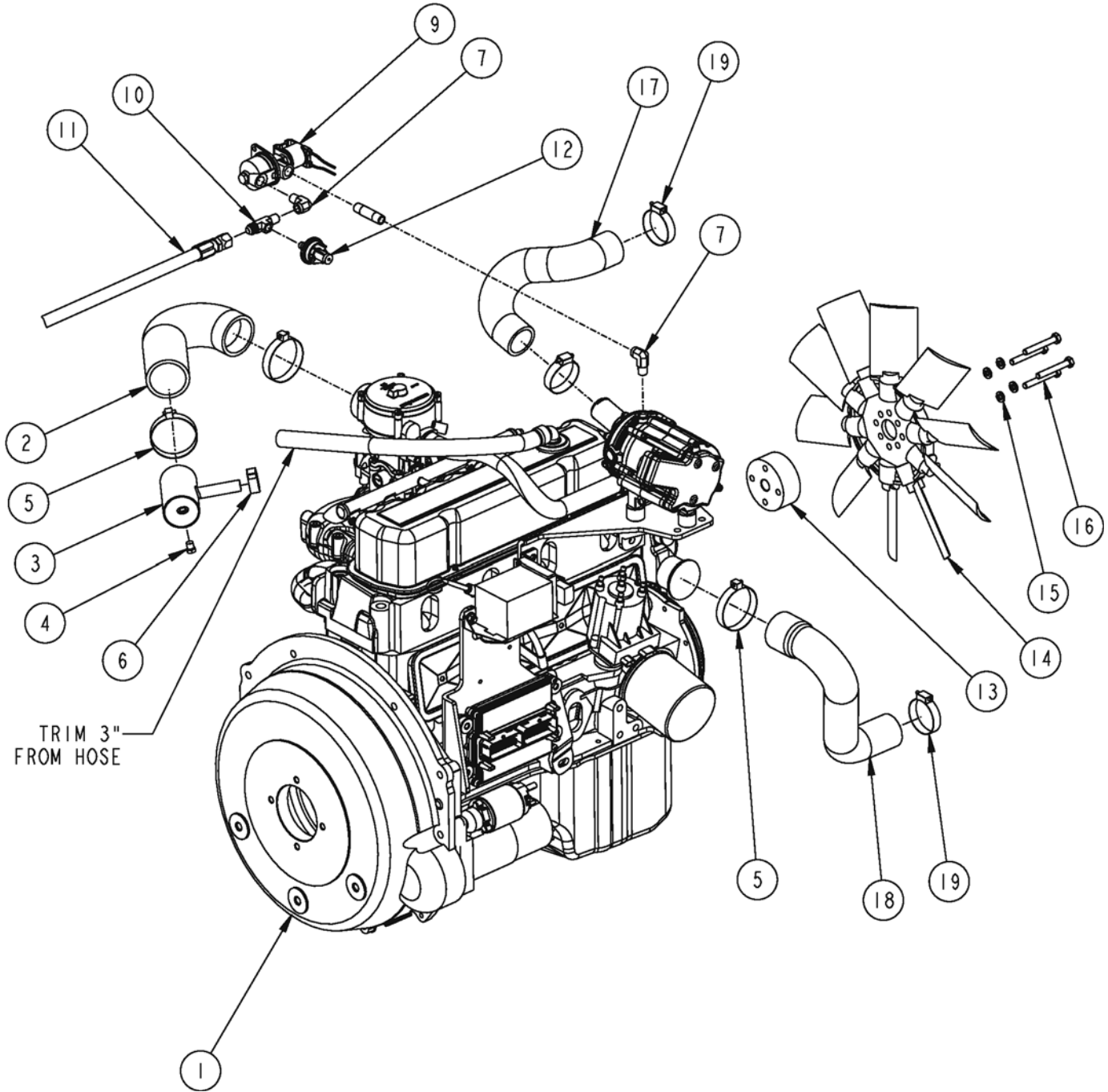

09-5	GM 3.0 LITER - LP ENGINE (FAN, AIR INTAKE & RADIATOR HOSES) IMPCO		
10-5	Granterra		61

Item	Ref. No.	Qty	Description
1#	0777-068	1	Engine, GM 3.0 LP (IMPCO)
2	8-33-02411	1	Hose, Air Intake
3	56305240	1	Tube (Weldment)
4	2-00-03778	1	Plug, 1/8 NPT
5	2-00-02216	3	Clamp, Hose
6	2-00-03407	1	Clamp, Witteck #10P
7	2-00-05678	1	Fitting, 1/4" NPT 90° Brass Street Elbow
9	7-88-00110	1	Valve, LP Safety (included with 0777-068)
10	56900921	1	Fitting, 1/4 NPT x 1/8 NPT x 3/8 JIC Tee
11	8-33-02415	1	Hose, LP High Pressure (102")
12	56418381	1	Switch-Low Pressure
13	7-75-01282	1	Spacer, Fan
14	8-23-00018	1	Fan, 15.5" Breeza
15	2-00-00530	4	Lock Washer, 5/16
16	2-00-06557	4	Screw, 5/16-24 x 2.25 Hex Head
17	8-33-02409	1	Hose, Upper Radiator
18	8-33-02410	1	Hose, Lower Radiator
19	2-00-03404	3	Clamp, Hose

= Revised or new since last update

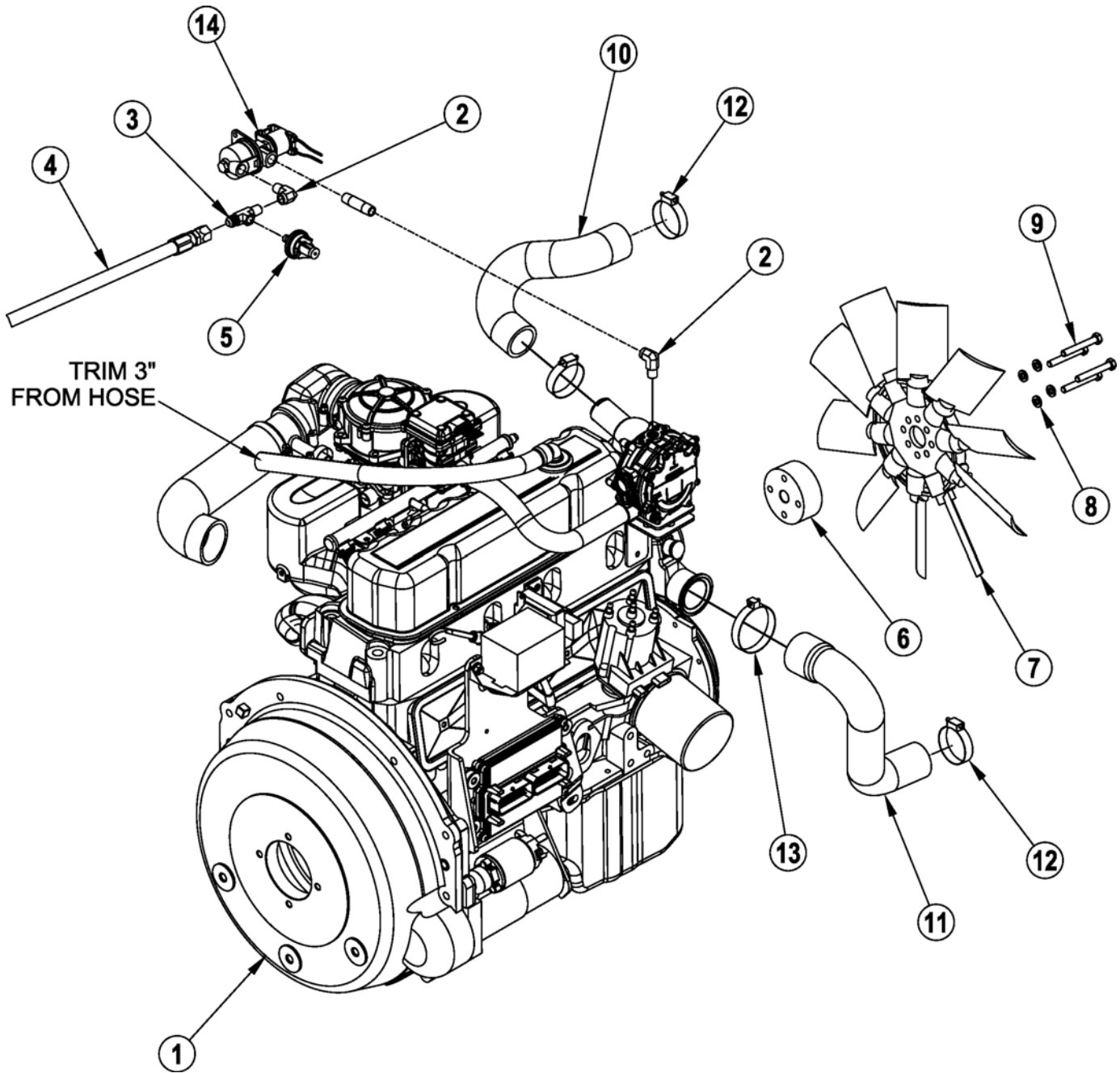

09-5	GM 3.0 LITER - LP ENGINE (FAN, AIR INTAKE & RADIATOR HOSES) PSI		
10-5	Granterra		63

Item	Ref. No.	Qty	Description
1#	56380126	1	Engine-PSI, GM 3.0 LP (PSI)
2#	2-00-05678	1	Fitting, 1/4" NPT 90° Brass Street Elbow
3#	56900921	1	Fitting, 1/4 NPT x 1/8 NPT x 3/8 JIC Tee
4#	8-33-02415	1	Hose, LP High Pressure (102")
5#	56418381	1	Switch-Low Pressure
6#	7-75-01282	1	Spacer, Fan
7#	8-23-00018	1	Fan, 15.5" Breeza
8#	2-00-00530	4	Lock Washer, 5/16
9#	2-00-06557	4	Screw, 5/16-24 x 2.25 Hex Head
10#	8-33-02409	1	Hose, Upper Radiator
11#	8-33-02410	1	Hose, Lower Radiator
12#	2-00-03404	3	Clamp, Hose
13#	2-00-02216	1	Clamp, Hose
14#	7-88-00110	1	Valve, LP Safety (included with 56380126)

= Revised or new since last update

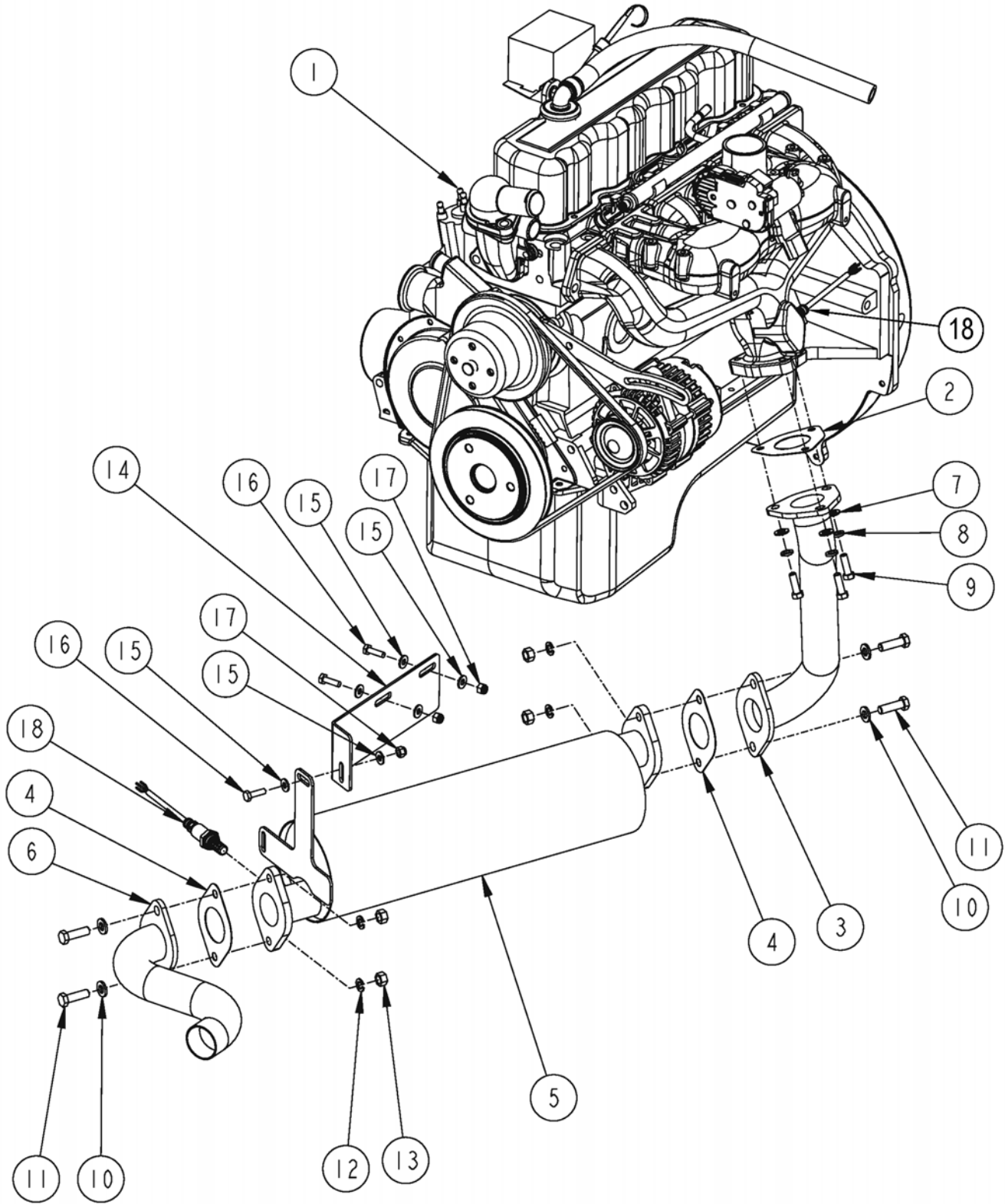

09-5	GM 3.0 LITER - GAS & LP ENGINES (EXHAUST SYSTEM)		
10-5	Granterra		65

Item	Ref. No.	Qty	Description
1#	0777-068	1	Engine, GM 3.0 LP (IMPCO)
#	0777-069	1	Engine, GM 3.0 GAS (IMPCO)
1#	56380126	1	Engine-PSI, GM 3.0 LP (PSI)
#	56380127	1	Engine-PSI, GM 3.0 GAS (PSI)
2#	7-29-00344	1	Gasket, Exhaust Flange NOTE 1
3	8-56-04060	1	Exhaust Downpipe
4#	7-29-00345	2	Gasket, Exhaust Flange NOTE 1
5#	7-49-00045	1	Muffler, Catalyst (Petrol & LPG) (IMPCO engines only) NOTE 1
#	56109496	1	Catalytic Converter (Petrol & LPG) (PSI engines only) NOTE 1
6	8-56-04061	1	Exhaust Tailpipe
7	2-00-00409	3	Flat Washer, .687 x .344 x .062
8	2-00-00530	3	Lock Washer, 5/16
9	2-00-04948	3	Screw, M8 x 1.25 x 25mm HHC
10	2-00-00402	4	Washer, 25/64 ID x 3/4 OD
11	2-00-00209	4	Bolt, 3/8-16 x 1.25 Hex Head
12	2-00-02310	4	Lock Washer, 3/8 Helical Spring
13	2-00-02360	4	Nut, 3/8-16 Hex
14	8-31-07014	1	Hanger, Muffler
15	2-00-03702	6	Washer, .625 x .281 x .063
16	2-00-01490	3	Screw, 1/4-20 x .875 Hex Head
17	2-00-00641	3	Nut, 1/4-20 Fiber Insert
18#	7-11-04081	2	O2 Sensor, GM 3.0 NOTE 1

= Revised or new since last update

NOTE 1: Shipped with the engine

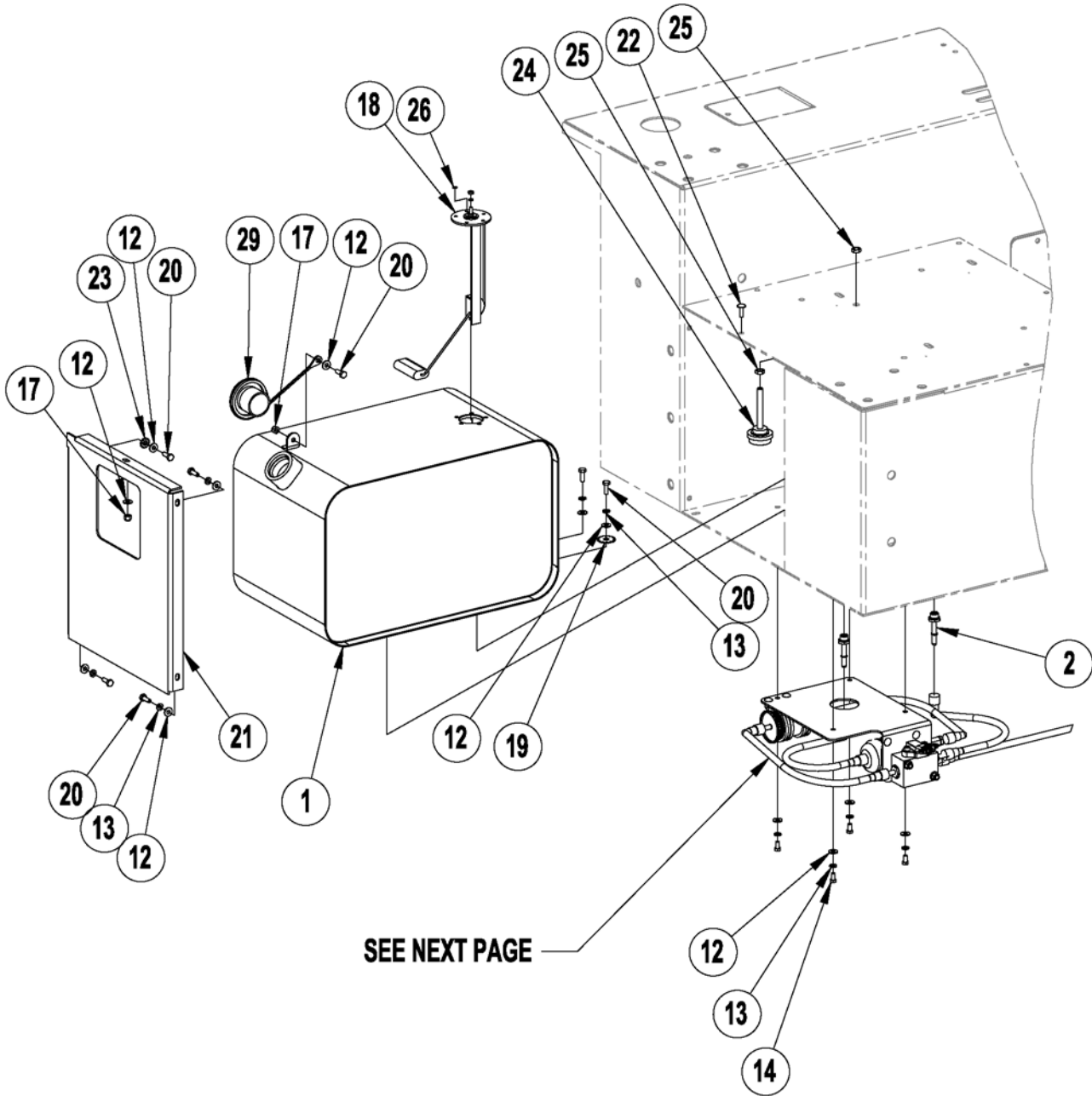

Item	Ref. No.	Qty	Description
1	56109112	1	Fuel Tank, Gas
2~	7-11-04083	4	Fitting, -6 SAE x 5/16 Quick Connect
3	8-08-00974	1	Bracket, Fuel System
4	7-13-07243	4	Clamp, Fuel Pump
5~	56305062	1	Fuel Pump
7~	56305412	1	Fuel Filter
8~	7-11-04082	1	Manifold, Fuel Temperature
9~	7-11-04084	1	Fitting, -3 SAE x 5/16 Quick Connect
10	8-33-02416	4	Fuel Line, Low Permeation
11	8-33-02417	1	Fuel Line, Low Permeation
12	2-00-03702	17	Washer, .625 x .281 x .063
13	2-00-00518	9	Lock Washer, 1/4" Helical Spring
14	2-00-00219	4	Bolt, 1/4-20 x 1/2 Hex Head
15	2-00-03575	4	Carriage Bolt, 1/4-20 x 3/4
16	2-00-00198	2	Carriage Bolt, 1/4-20 x 2.0
17	2-00-00641	7	Nut, 1/4-20 Fiber Insert
18	8-26-04003	1	Float, Fuel Level
19	2-00-03829	1	Lock Washer, 3/8" Int/Ext Tooth
20	2-00-00221	6	Bolt, 1/4-20 x 3/4 Fin. Hex Head
21	56516835	1	Rear Wall, Seat Compartment
22	2-00-00183	1	Screw, 1/4-20 x 3/4 round Head
23	2-00-00503	1	Lock Washer, 1/4-20
24	7-50-05144	1	Pad
25	2-00-02369	2	Nut, 3/8-16
26	2-00-00512	1	Star Washer
27	2-00-06572	1	Nut, M4 Distorted Thread
28	2-00-06573	1	Nut, M5 Distorted Thread
29	56508354	1	Cap

* = Not Shown

-Comes with 0777-069 Engine Assembly

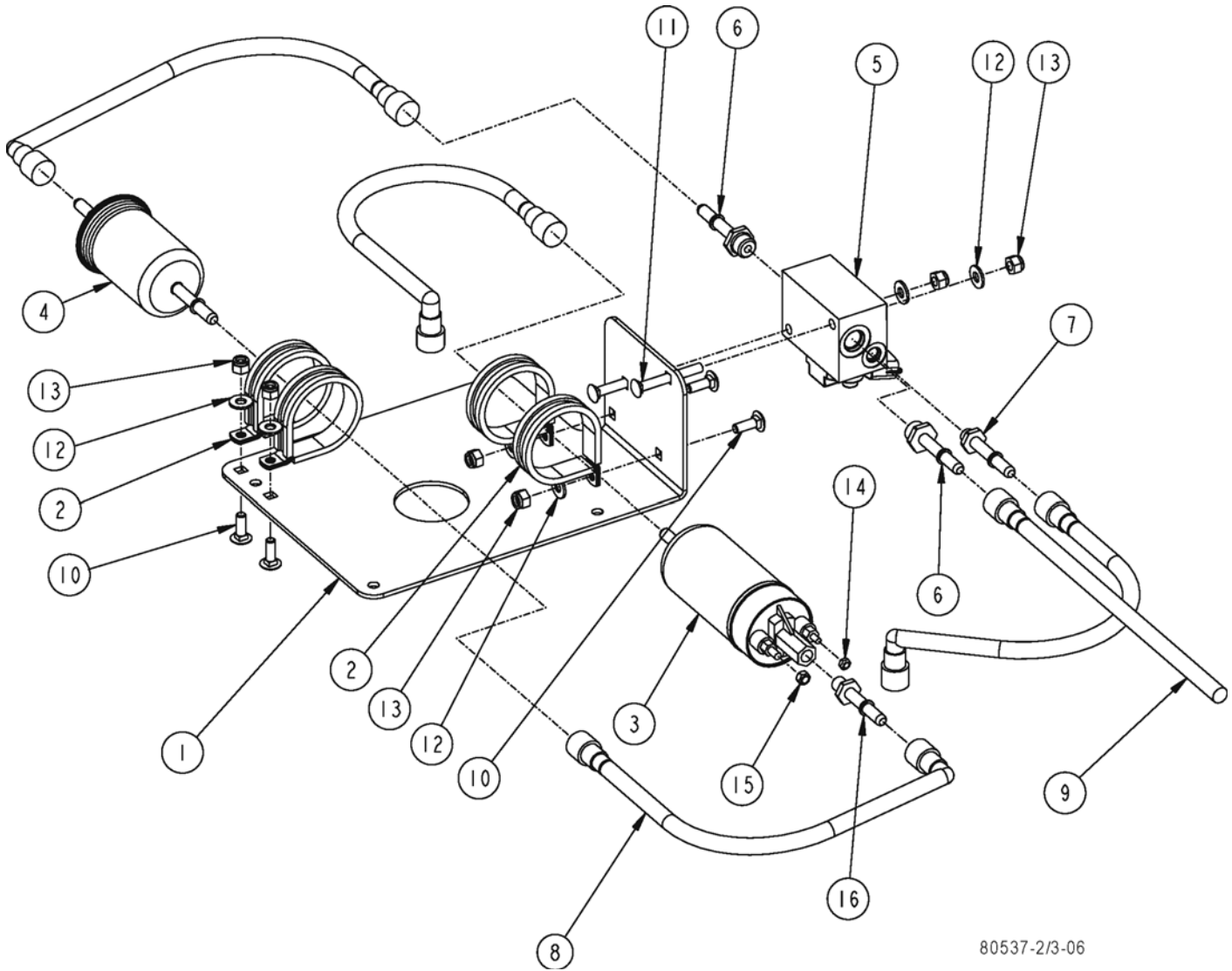

80537-2/3-06

Item	Ref. No.	Qty	Description
1	8-08-00974	1	Bracket, Fuel System
2	7-13-07243	4	Clamp, Fuel Pump
3~	56305062	1	Fuel Pump
4~	56305412	1	Fuel Filter
5~	7-11-04082	1	Manifold, Fuel Temperature
6~	7-11-04083	2	Fitting, -6 SAE x 5/16 Quick Connect
7~	7-11-04084	1	Fitting, -3 SAE x 5/16 Quick Connect
8	8-33-02416	4	Fuel Line, Low Permeation
9	8-33-02417	1	Fuel Line, Low Permeation
10	2-00-03575	4	Carriage Bolt, 1/4-20 x 3/4
11	2-00-00198	2	Carriage Bolt, 1/4-20 x 2.0
12	2-00-03702	6	Washer, .625 x .281 x .063
13	2-00-00641	6	Nut, 1/4-20 Fiber Insert
14	2-00-06572	1	Nut, M4 Distorted Thread
15	2-00-06573	1	Nut, M5 Distorted Thread
16~	56109052	1	Fitting, Fuel Pump

~Comes with 0777-069 Engine Assy.

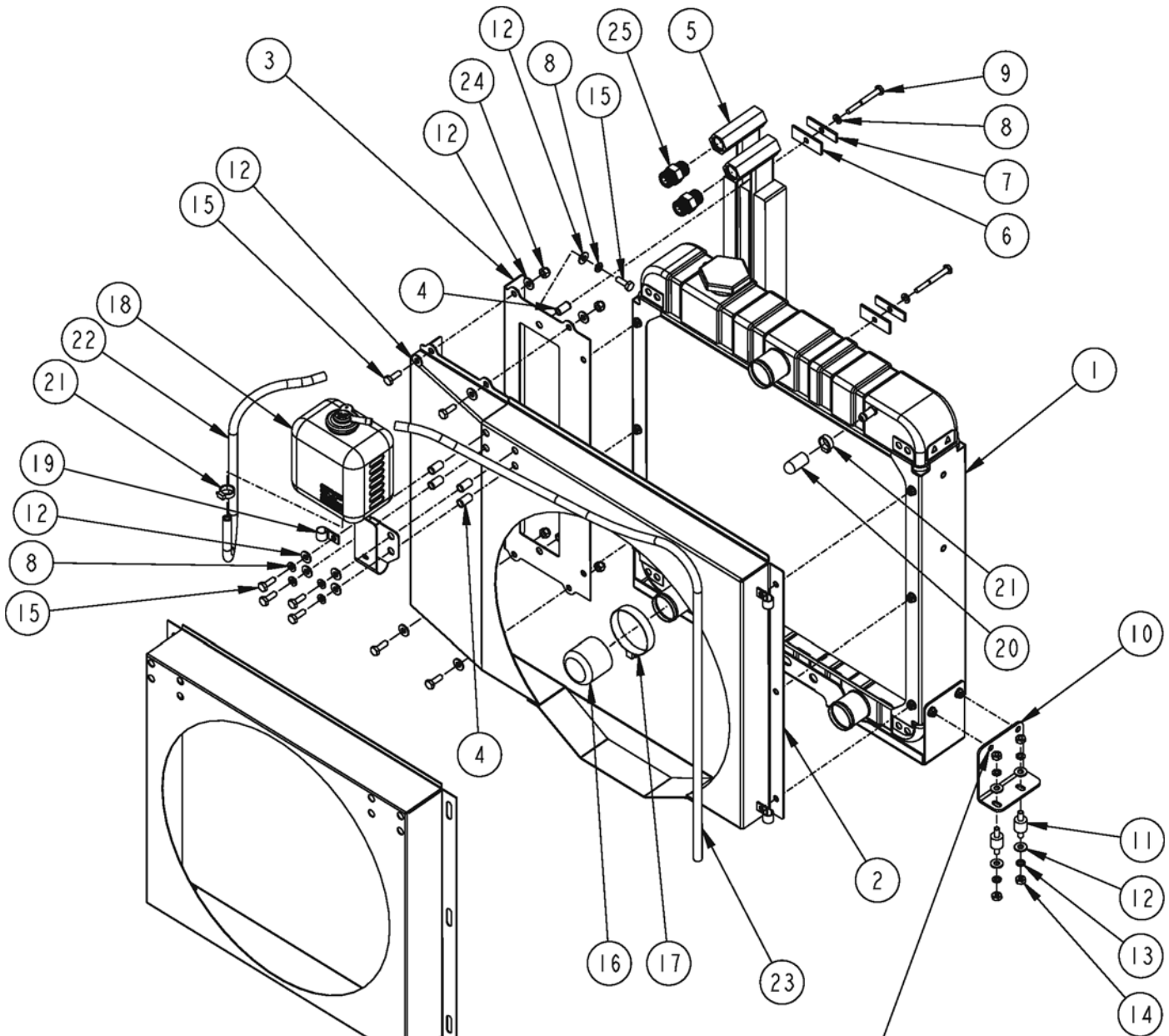

USE BOLTS THAT COME WITH RADIATOR

REMOVE SHROUD THAT COMES WITH RADIATOR 7-62-01008

Item	Ref. No.	Qty	Description
1	7-62-01008	1	Radiator
2	8-72-00021	1	Shroud, Radiator
3	8-72-00022	1	Shroud, Oil Cooler
4	2-00-05261	6	Insert, 1/4-20 Threaded
5	8-62-01018	1	Oil Cooler
6	7-29-00192	2	Gasket, Oil Cooler
7	8-13-07088	2	Clip
8	2-00-00518	8	Lock Washer, 1/4" Helical Spring
9	2-00-00246	2	Bolt, 1/4-20 x 2.25 Hex Head
10	8-08-00946	1	Bracket, Radiator Mounting
11	8-50-05053	2	Isolator, Radiator Mount
12	2-00-03702	18	Washer, .625 x .281 x .063
13	2-00-00501	4	Washer, .25 ID x .44 OD x .046
14	2-00-00594	4	Nut, 1/4-20 Hex
15	2-00-00221	10	Screw, 1/4-20 x 3/4 HHC
16	2-00-05956	1	Plug, Radiator Outlet
17	2-00-02216	1	Clamp, Hose
18	7-07-02002	1	Overflow Bottle Assy. (1 liter)
19	2-00-04602	3	Clamp
20	2-00-05985	1	Cap, 3/8 ID x 1 Inside Length (Rubber)
21	2-00-05363	2	Clamp, Hose
22	7-33-02642	1	Hose, 1/4" ID x 18" long (Black)
23	7-33-02643	1	Hose, 1/4" ID x 36" long (Black)
24	2-00-00641	4	Nut, 1/4-20 Fiber Insert
25	2-00-04970	2	Fitting, Str. -8 ORS x -8 SAE

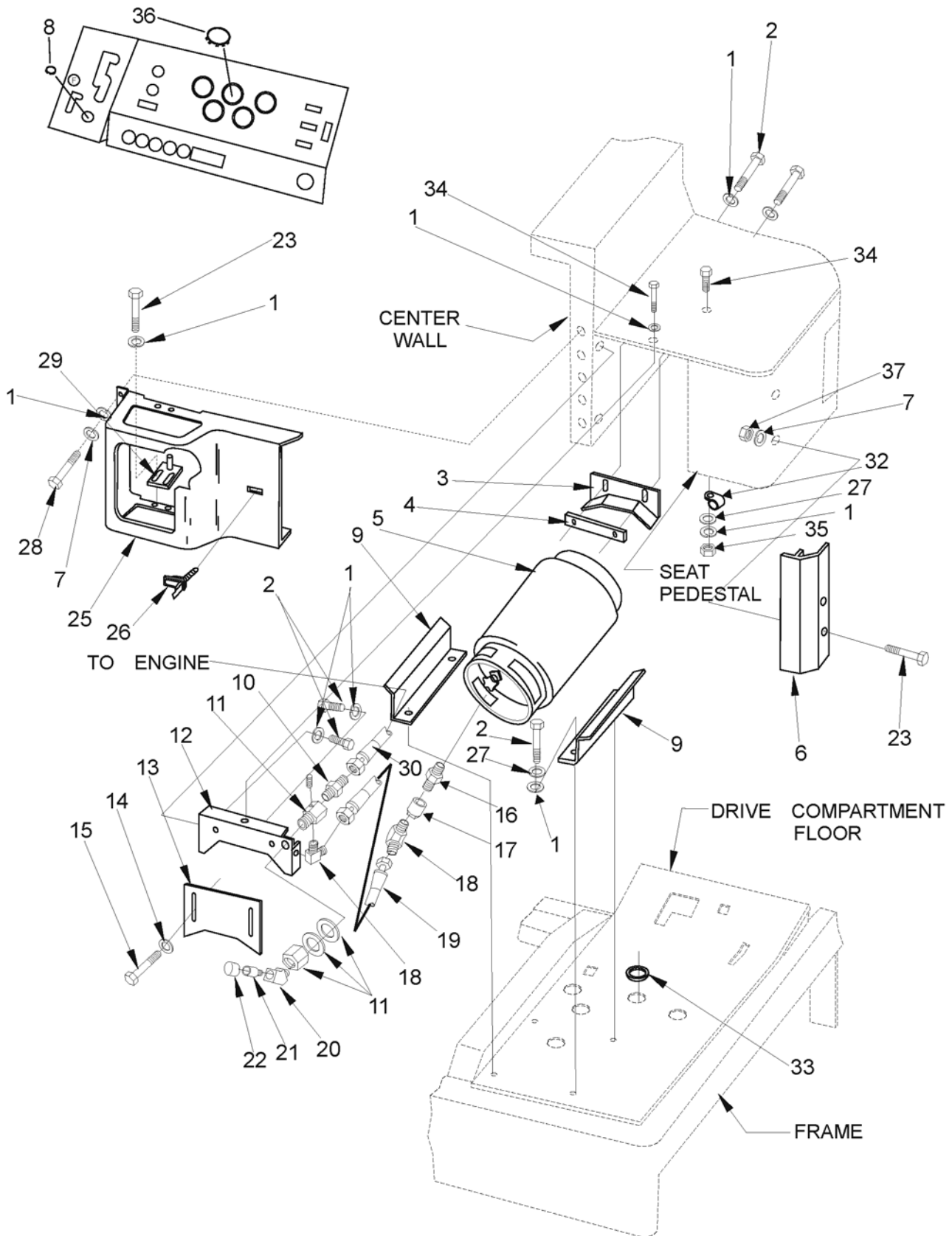

09-5	LP TANK SYSTEM		
09-10	Granterra		73

Item	Ref. No.	Qty	Description
1	2-00-00518	12	Lock Washer, Helical Spring 1/4 Med
2	2-00-00219	9	Screw, 1/4-20 x .500 HHC
3	56516859	1	Rear Retainer
4	56516858	1	Bracket, Tapped
5	56456590	1	LP Tank
6	56516853	1	Bumper, LP Tank Stop
7	2-00-02312	5	Lock Washer, Helical Spring 1/2 Med
8-	REF		Light, Check Engine (Gas/LP)
	2-00-04757	1	Hole Plug (Diesel)
9	56516857	2	Tank Support
10*		1	Fitting, 1/4 NPT x 3/8 SAE Str.
11*		1	Fitting, Bulk Head Plus Hardware
12	56516856	1	Wall, Seat Compartment
13	56516855	1	Retainer, LP Tank
14	2-00-00409	2	Flat Washer, 5/16
15	2-00-04867	2	Screw, 5/16-18 x 1.000 Thumb
16*		1	Fitting (comes with LP tank)
17*		1	Coupling
18*		2	Fitting, 1/4 NPT x 3/8 SAE 90 elbow
19*		1	Hose, Tank to Relief Valve
20*		1	Fitting, 1/4 NPT x 1/4 FM 45 Elbow
21*		1	Relief Valve
22*		1	Plastic Cap
23	2-00-00239	5	Screw, 1/2-13 x 1.000 HHC
25	56516854	1	Bumper, LP Tank Stop
26	8-41-00040	1	Latch, Bumper
27	2-00-00407	7	Flat Washer, .562 x .265 x .062
28	2-00-00221	2	Screw, 1/4-20 x .750 HHC
29	8-08-00620	1	Bracket, Locating Pin
30	8-33-02262	Ref	Hose, 88", Engine to Relief Valve (FORD)
32	2-00-04564	1	Clamp, Cable
33	8-09-01077	1	Grommet
34	2-00-00205	1	Screw, 1/4-20 x 1.00 HHC
35	2-00-00594	1	Nut, Hex 1/4-20 x .437 x .218
36	7-11-04035	1	Kit, Low LP Indicator Light
37	2-00-00596	2	Nut, 1/2-13

*All Parts without a number are contained in LP Kit Number 8-11-04014

~Comes with Engine Assembly

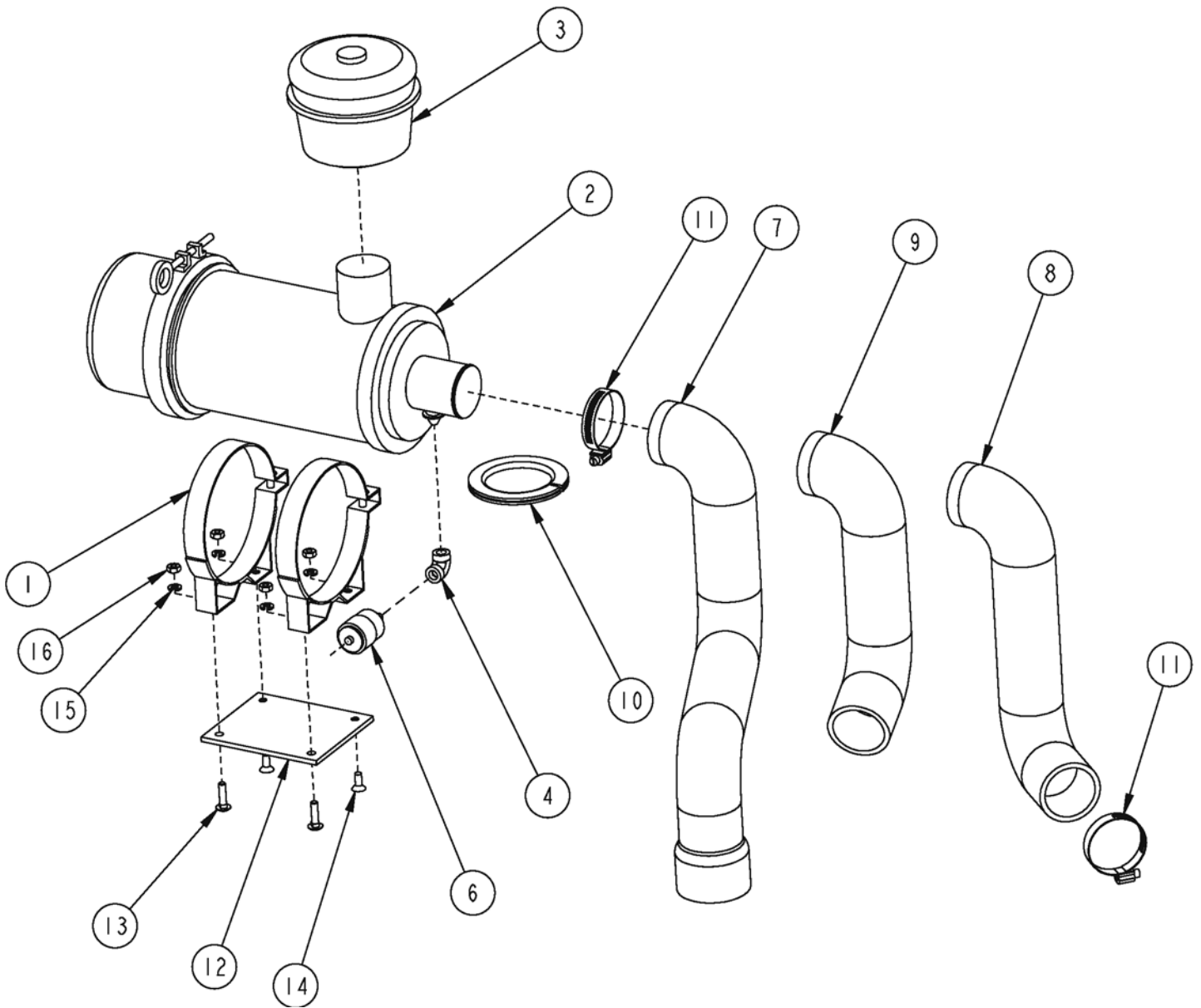

Item	Ref. No.	Qty	Description
1	8-24-04093	2	Clamp, Air Cleaner
2	8-24-04100	1	Air Cleaner Assembly
	8-24-04106		Air Cleaner Element (exterior)
	8-24-04111		Air Cleaner Element (interior)
3	8-24-04092	1	Filter, Dust Bowl
4	2-00-03641	1	Elbow, 1/8 NPT
5			Intentionally Omitted
6	7-24-04087	1	Filter Service Indicator 20" WC (Diesel)
	56478461	1	Indicator, Service (Gasoline / Petrol & LPG)
7	8-33-02369	1	Hose, Intake (Diesel)
8	8-33-02412	1	Hose, Intake (LPG)
9	8-33-02413	1	Hose, Intake (Gasoline / Petrol)
10	7-21-04022	1	Edging
11	2-00-02217	2	Clamp, Hose
12	56516844	1	Plate, Filter Assy.
13	2-00-02196	2	Carriage Bolt, 1/4-20 x 1.00
14	2-00-03027	2	Screw, 1/4-20 x .63 Cap
15	2-00-00518	4	Lock Washer, 1/4 Helical Spring
16	2-00-00594	4	Nut, 1/4-20 Hex

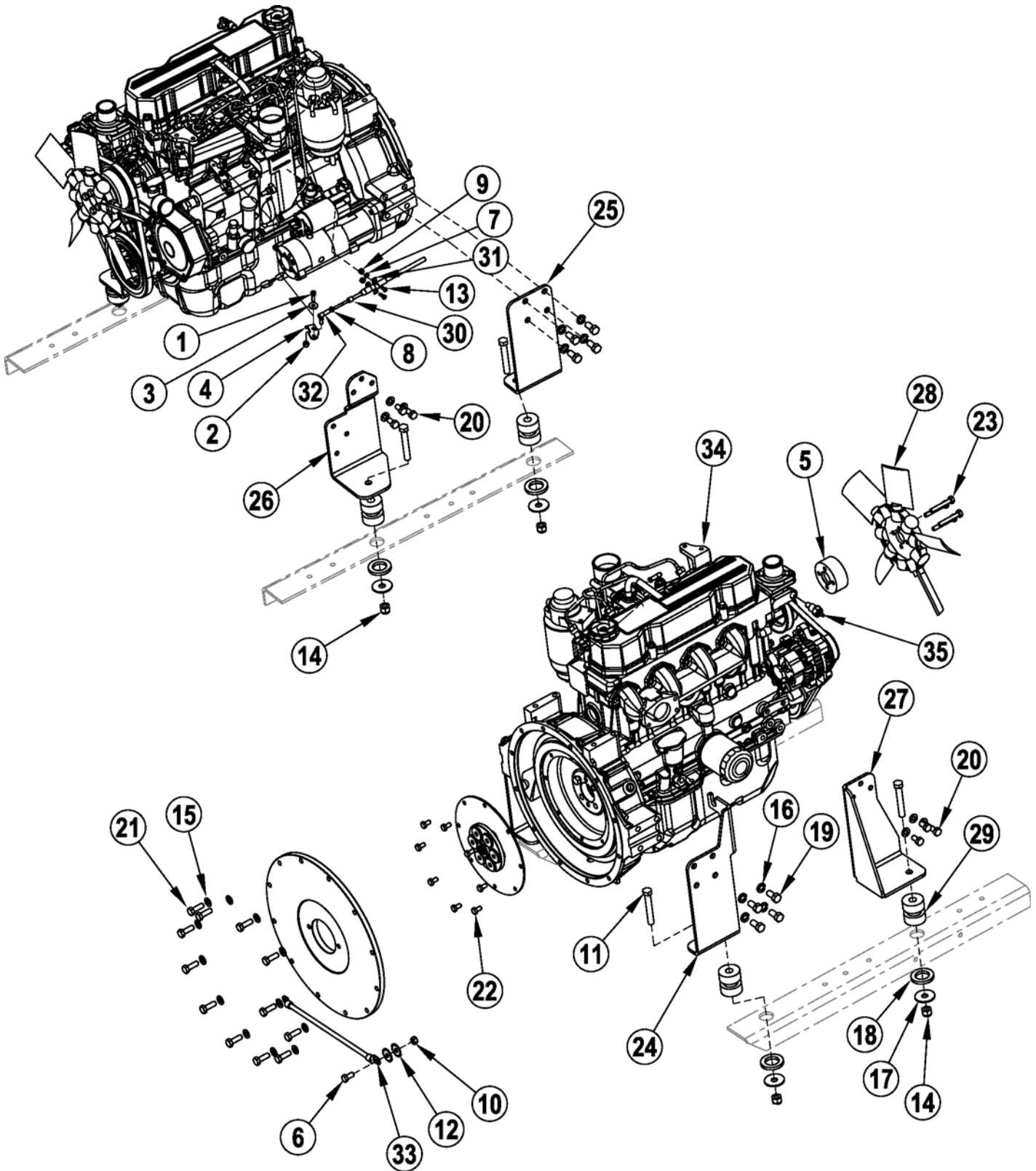

09-5	MITSUBISHI S4Q2 TIER 4 - DIESEL ENGINE (FAN, BRACKETS, THROTTLE)		
10-5	Granterra		77

Item	Ref. No.	Qty	Description	Item	Ref. No.	Qty	Description
1	56003368	1	Scr, Soc Hd M6-1.0 X 20.0	*	7-24-04088	1	Filter Water Separator S4Q2
2	56003403	1	Nut, Hex Nyl Loc M6-1	*	56109470	1	Bracket Throttle Cable Mtg
3	56003638	1	Wsh, Flt SS 6mm	*	56109481	1	Pipe Cylinder 1 S4Q2 T4
4	56109471	1	Arm Engine Throttle	*	56109482	1	Pipe Cylinder 2 S4Q2 T4
5	7-75-01248	1	Spacer, Fan Mitsubishi S4Q2	*	56109483	1	Pipe Cylinder 3 S4Q2 T4
6	2-00-00232	1	Bolt-Hex Head, Finished, 3/8-16	*	56109484	1	Pipe Cylinder 4 S4Q2 T4
7	2-00-00426	2	Washer-Flat .500 X .219 X .063	*	56109492	1	Pipe Return Fuel
8	2-00-00626	1	10-32 Nut	*	2-00-05968	1	Belt, Waterpump/Alternator Mitsu S4Q2
9	2-00-01246	2	Nut-#10-24 Elastic Stop Nut	*	7-24-04097	1	Filter, Oil Mitsubishi S4Q2
10	2-00-02360	1	Nut, Hex, 3/8-16	*	7-56-04079	1	Pipe, Balance Mitsubishi S4Q2
11	2-00-02617	4	Screw, 1/2-13 X 3.5 Lg, SS	*	7-60-05048	1	Pump, Water Mitsubishi S4Q2
12	2-00-03829	2	Lock Washer, 3/8 Int./Ext. Tooth	*	7-75-03004	4	Glow Plug, Mitsubishi S4Q2
13	2-00-04794	2	Screw, #10-24 X .63 BHS	*	0769-029	4	Injector, Mitsubishi S4Q2
14	2-00-04936	4	Locknut-Elastic, 1/2-13	*	0775-285	1	Starter, Mitsubishi S4Q2
15	2-00-05042	18	M10 Helical Spring LW	*	0775-287	1	Alternator, Mitsubishi S4Q2
16	2-00-05043	8	Washer-Plain, 25/64 ID X 3/4 OD	*	7-29-00312	1	Gasket, Thermostat Mitsubishi S4Q2
17	2-00-05067	4	Spacer, Snubbing Washer	*	7-84-08016	1	Thermostat, Mitsubishi S4Q2
18	2-00-05955	4	Washer				
19	2-00-05957	8	HHC, M12 X 1.75 X 25mm				
20	2-00-05958	6	HHC, M10 X 1.25 X 20mm				
21	2-00-05961	12	HHC, M10 X 1.25 X 30mm				
22	2-00-05963	8	HHC, M8 X 1.25 X 15mm 8.8 Blox				
23	2-00-05981	4	HHC, M8 X 1.25 X 55mm				
24	7-08-01192	1	Bracket, Engine Mount				
25	7-08-01193	1	Bracket, Engine Mount				
26	7-08-01194	1	Bracket, Engine Mount				
27	7-08-01195	1	Bracket, Engine Mount				
28	7-23-00022	1	Fan, Mitsubishi S4Q2 Engine				
29	7-35-00017	4	Isolator, Engine Mount (Red Dot)				
30	8-10-00033	1	Cable-Throttle-57» LG.				
31	8-13-07094	1	Conduit Clamp				
32	8-25-02036	1	Ball Joint Connector				
33	8-90-07328	1	Wire, Ground To Frame				
34	56109479	1	Engine Assy, Mitsubishi S4Q2 T4				
35#	8-69-00014	1	Sender, Water Temperature				

= Revised or new since last update

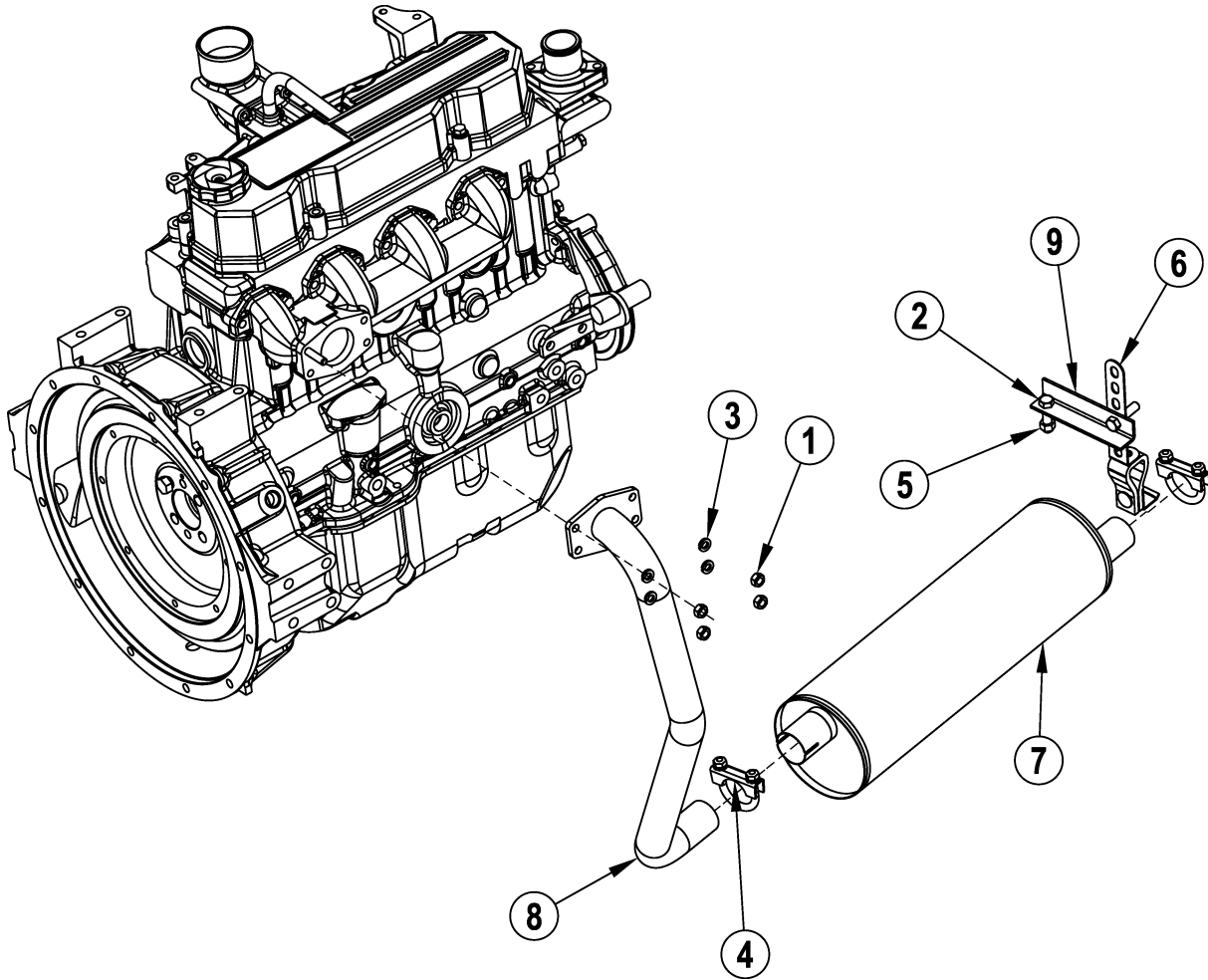

Item	Ref. No.	Qty	Description
1	56003352	4	Nut, Hex M8-1.25
2	2-00-00234	2	Screw, 3/8-16 X 1-1/2 HHC
3	2-00-00530	4	5/16" Lock Washer
4	2-00-04040	2	Clamp - Muffler 1 1/4
5	2-95-04182	2	Nut, Hex, Stop, 3/8-16
6	7-31-07017	1	Hanger-Muffler
7	7-49-00031	1	Muffler
8	7-87-02933	1	Tube, Exhaust
9	8-08-00861	1	Bracket, Muffler Hanger

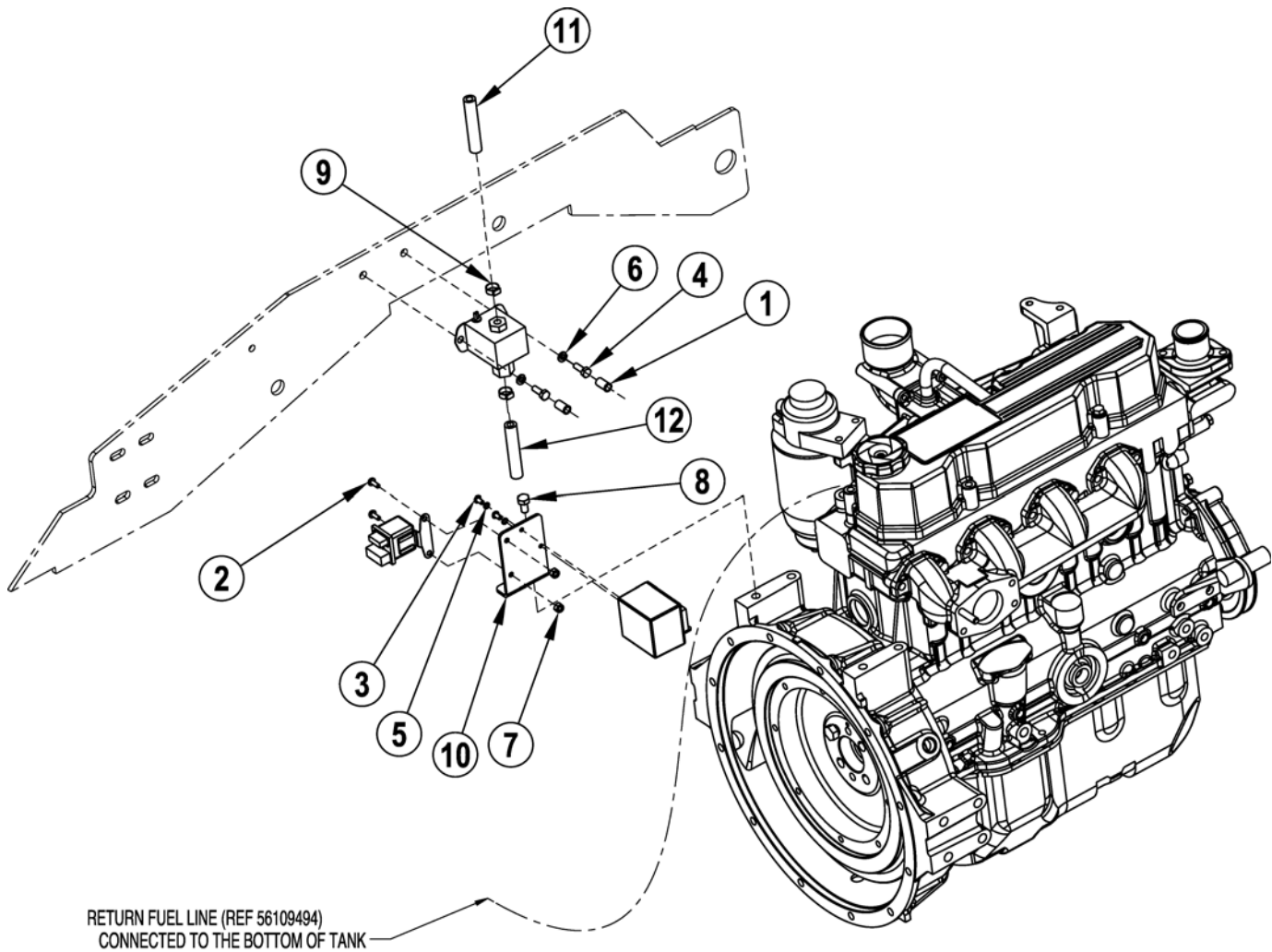

Item	Ref. No.	Qty	Description
1	2-00-05261	2	Nutsert, 1/4-20
2	2-00-00049	2	Scw-Rhm 10-24 X .50 Zn Pl
3	2-00-00052	2	Screw - #10-24 X .38 RHMS
4	2-00-00221	2	Bolt-Hex Head, Finished, 1/4-20 x 3/4 LG
5	2-00-00512	2	Washer, Star
6	2-00-00518	2	Washer, Lock, 1/4" Helical Spring
7	2-00-01246	2	Nut-#10-24 Elastic Stop Nut
8	2-00-05963	1	HHC, M8 X 1.25 X 15mm 8.8 Blox
9	2-95-04388	2	Clamp, Hose
10	8-08-00936	1	Bracket, Murphy
11	8-33-02154	1	Hose, Fuel
12	8-33-02338	1	Hose, Fuel

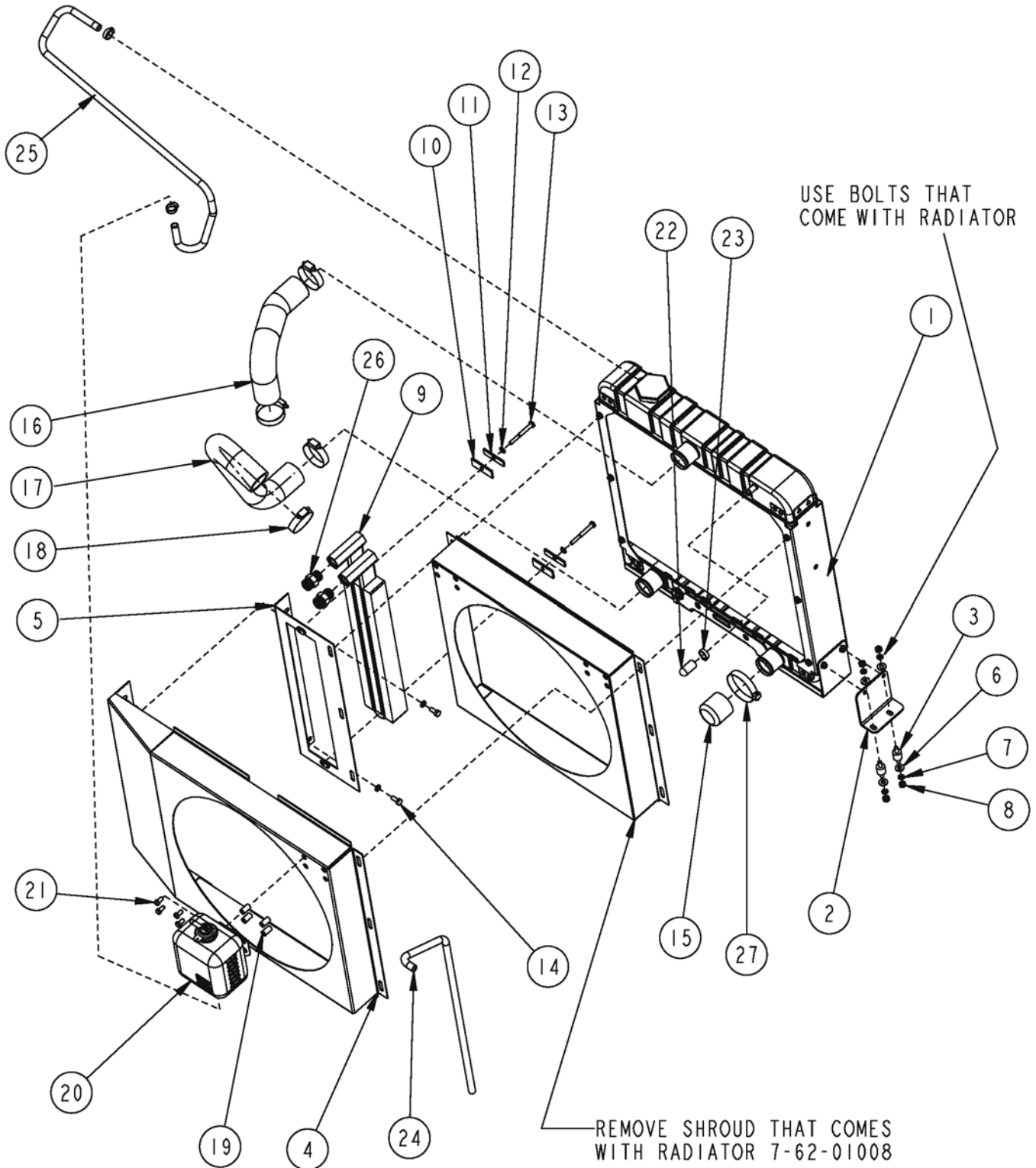

Item	Ref. No.	Qty	Description
1	7-62-01008	1	Radiator
2	8-08-00946	1	Bracket, Radiator Mounting
3	8-50-05053	2	Isolator, Radiator Mount
4	8-72-00020	1	Shroud, Radiator
5	8-72-00019	1	Shroud, Oil Cooler
6	2-00-03702	4	Washer, .625 x .281 x .063
7	2-00-00501	4	Washer, .25 ID x .44 OD x .046
8	2-00-00594	4	Nut, 1/4-20 Hex
9	8-62-01018	1	Oil Cooler
10	7-29-00192	2	Gasket, Oil Cooler
11	8-13-07088	2	Clip
12	2-00-00518	4	Lock Washer, 1/4" Helical Spring
13	2-00-00246	2	Bolt, 1/4-20 x 2.25 Hex Head
14	2-00-00220	2	Screw, 1/4-20 x .625 HHC
15	2-00-05956	1	Plug, Radiator Outlet
16	8-33-02367	1	Hose, Upper Radiator
17	7-33-02615	1	Hose, Lower Radiator
18	2-00-03404	4	Clamp
19	2-00-05261	4	Insert, 1/4-20 Threaded
20	7-07-02002	1	Overflow Bottle Assy. (1 liter)
21	2-00-00219	4	Bolt, 1/4-20 Fin. Hex Head
22	2-00-05985	1	Cap, 3/8 ID x 1 Inside Length (Rubber)
23	2-00-05363	3	Clamp, Hose
24	7-33-02724	1	Hose, 1/4" ID x 28" long (Clear)
25	7-33-02643	1	Hose, 1/4" ID x 36" long (Black)
26	2-00-04970	2	Fitting, Str. -8 ORS x -8 SAE
27	2-00-02216	1	Clamp, Hose

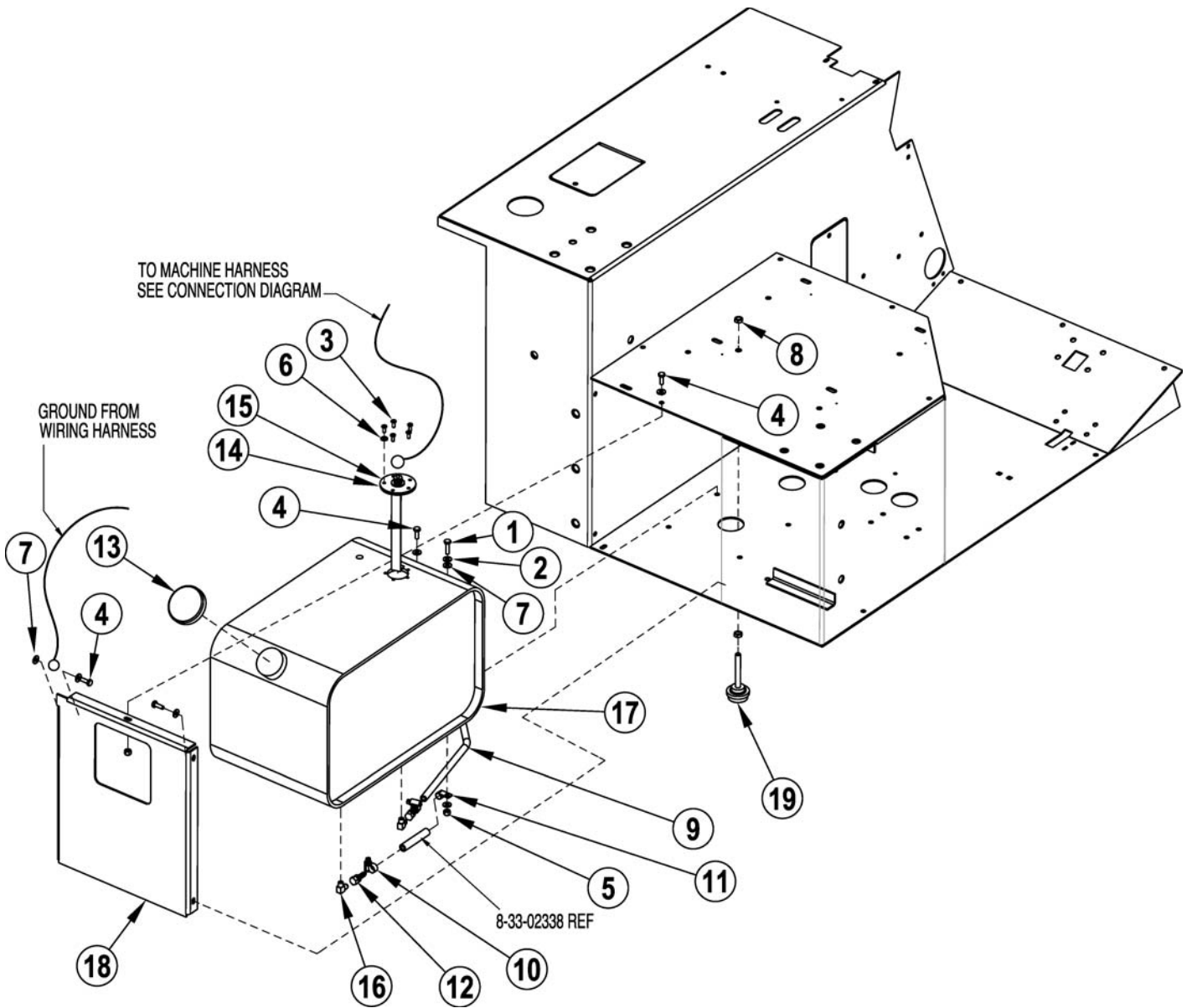

Item	Ref. No.	Qty	Description
1	56002093	1	Scr, Hex 1/4-20 x 1.00
2	56002098	5	Wsh, Fit SAE 1/4
3	56002147	5	Scr, Pan Phil 10-32 x .50
4	56002155	4	Scr, Hex 1/4-20 x .75
5	56002708	2	Nut, Hex Nyl Loc 1/4-20
6	56009011	1	Wsh, Int Shprf #10
7	56009064	3	Wsh, Int Shprf 1/4
8	56009085	2	Nut-Hex Jam 3/8-16
9	56109494	1	Hose Fuel 1/4 Id 52 Long
10	56756364	2	Clamp, Hose SAE #4
11	2-00-04602	1	Clamp
12	2-00-04618	2	Fitting
13	7-11-00029	1	Cap Fuel Tank
14	7-29-00348	1	Gasket, Sending Unit
15	8-26-04003	1	Float/Sender
16	8-56-05021	2	Fitting
17	8-83-04029	1	Tank, Gas
18	56516835	1	Rear Wall - Seat Compartment
19	7-50-05144	1	Pad

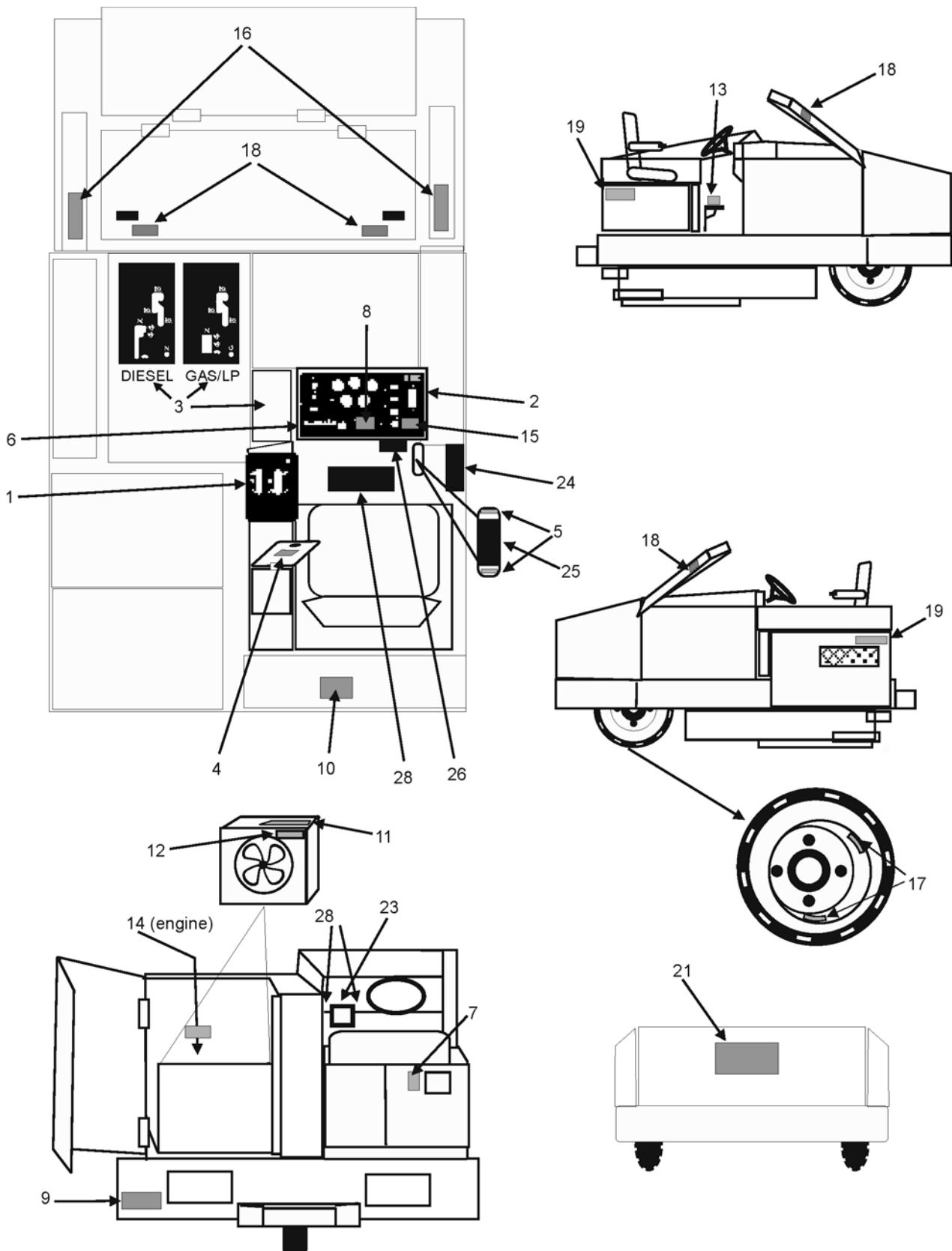

Item	Ref. No.	Qty	Description
1	8-18-00518	1	Hopper Controls
2	8-18-00512	1	Instrument Panel
3	8-18-00519	1	Main Broom & Throttle (Diesel only)
	8-18-00555	1	Main Broom & Throttle (Gas/LPG only)
4*	REF	1	Hydraulic Fluid Only
5	8-18-00490	1	Bi-directional Pedal (horizontal)
6	8-18-00487	1	Blank Squares - Option Cover
7<	REF	1	Gasoline Only
	56109404	1	Decal, Low Sulfur Diesel (Diesel Only)
8*<	REF	1	Do Not Use With Flammables
9*<	REF	1	Exhaust Warning
10<	REF	1	Fire Hazard
11<	REF	1	Moving Belts - Stay Clear
12<	REF	1	Moving Fan Blade-Stay Clear
13*<	REF	1	Patent/Patent Pending
14<	REF	1	Surface Hot - Stay Clear
15<	REF	1	Turn Off - Lock Wheel
16*<	REF	2	Put Hopper in Forward Dump Position
17*<	REF	3	Split rim (Pneumatic Tire)
18<	REF	4	Pinch Point - Stay Clear
19	56516907	2	DECAL-Granterra
21	56016730	1	Decal-Advance
23	REF	1	Serial Number Plate
24	7-50-05136	1	Non-Skid, Frame Edge
25	8-50-05055	1	Non-Skid, Forward/Reverse Pedal
26	8-50-05050	1	Non-Skid, Brake Pedal
27	8-50-05052	1	Non-Skid, Drive Compartment Floor
28	2-00-04115	2	Pop Rivet

<English Text and No-text warning decals contained in kit 0760-871

*ALL WARNING/SAFETY DECALS WITH TEXT SOLD IN A KIT BY LANGUAGE:

DANISH	0760-850	ITALIAN	0760-851
DUTCH	0760-849	FRENCH	0760-847
NORWEGIAN	0760-852	SPANISH	0760-846
SWEDISH	0760-853	PORTUGUESE	0760-854
GERMAN	0760-848		

TIMED FILTER SHAKER OPTION ONLY

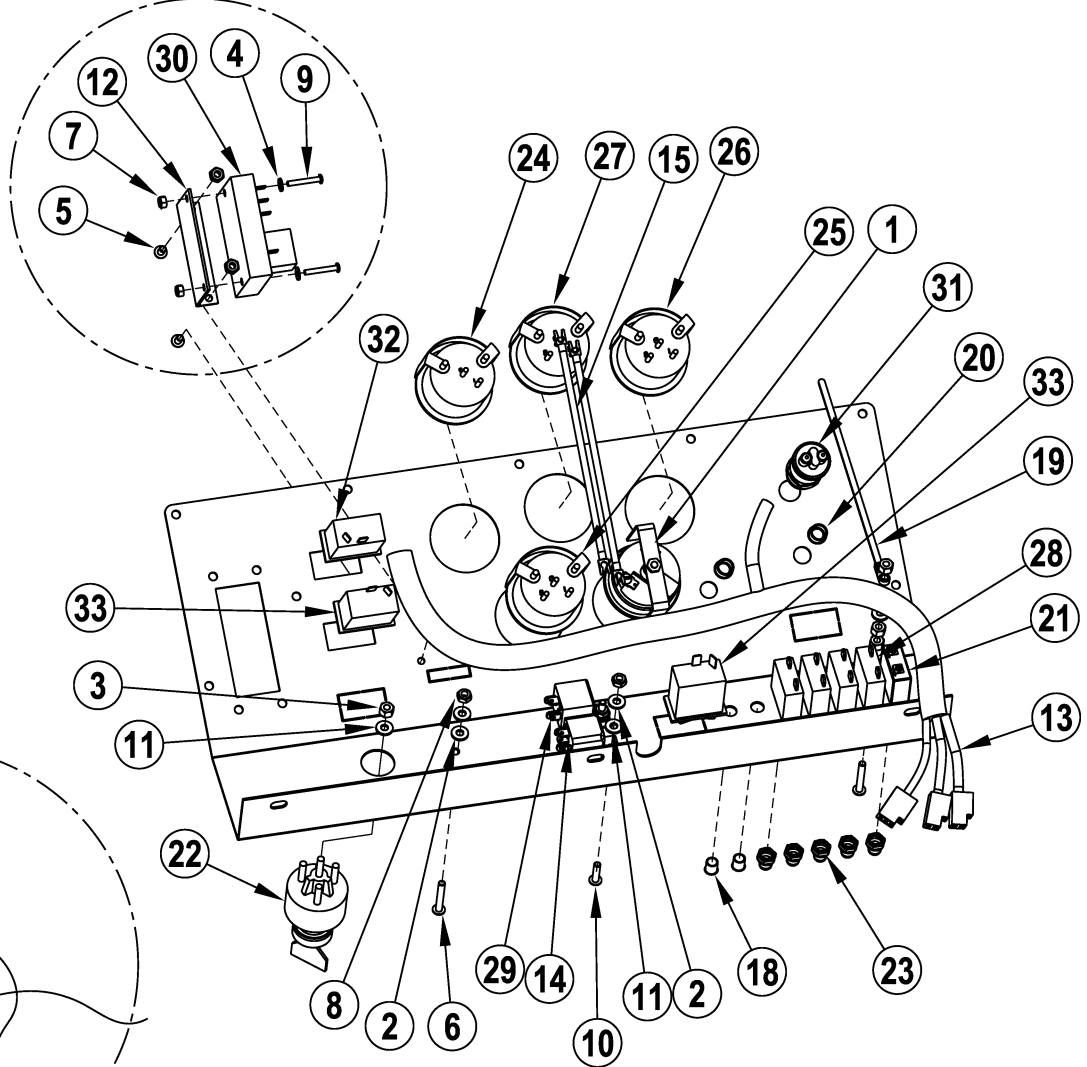

USED ONLY WHEN TIMED SHAKER OPTION IS NOT INSTALLED

Item	Ref. No.	Qty	Description
1	56478363	1	Meter, Hour
2	56001954	3	Wsh, Flt SAE #10
3	56001987	4	Nut, Hex Machine 10-32
4	56002006	2	Wsh, Flt SAE #6
5	56002043	2	Scr, Pan Phil 10-24 X .38
6	56002824	2	Scr, Pan Phil 10-24 X 1.25
7	56002830	2	Nut, Hex Nyl Loc 6-32
8	56002832	5	Nut, Hex Nyl Loc-Thin 10-24
9	56002858	2	Scr, Pan Phil 6-32 X 1.00
10	56002894	2	Scr, Pan Phil Ss 10-24 X .75
11	56009011	6	Wsh, Int Shprf #10
12	56516763	1	Bracket Relay
13	0895-132	1	Instrument Panel Harness
14	8-64-05009	1	Relay-12 VDC
15	8-90-07357	2	Wire Wt Gage To Fuel Gage (Gas & Diesel only)
16	8-90-07361	1	Wire Td-1 6to7 To M286 to M4
17	8-90-07385	1	Wire Jumper
18	2-00-04757	2	Plug Button, .375 Dia.
19	2-00-04937	1	Tie, Cable
20	2-00-04942	2	Plug .50 Dia. (Light Switch)
21	7-64-00025	1	Circuit Breaker- 25 Amp
22	7-82-00026	1	Switch, Key - Anti Re-Start (Key only: 2-60-02272)
23	8-11-00044	5	Boot (Circuit Breaker)
24	8-48-00016	1	Voltmeter
25	8-48-05027	1	Gauge, Oil Pressure
26	8-48-05028	1	Gauge, Water Temperature
27	8-48-05032	1	Gauge, Fuel (Gas & Diesel only)
	7-11-04035	1	Kit, Low LP Indicator Light (LP only)
28	8-64-00008	4	Circuit Breaker- 15 Amp
29	8-64-00012	1	Relay-Shaker Motor
30	8-64-05011	1	Timer (20 Sec. Time Delay) (Option)
31	8-82-00024	1	Horn, Push Button
32	8-82-00059	1	Switch-Rocker (SPST)
33	8-82-00062	2	Switch-Rocker (SPST) (Diesel)

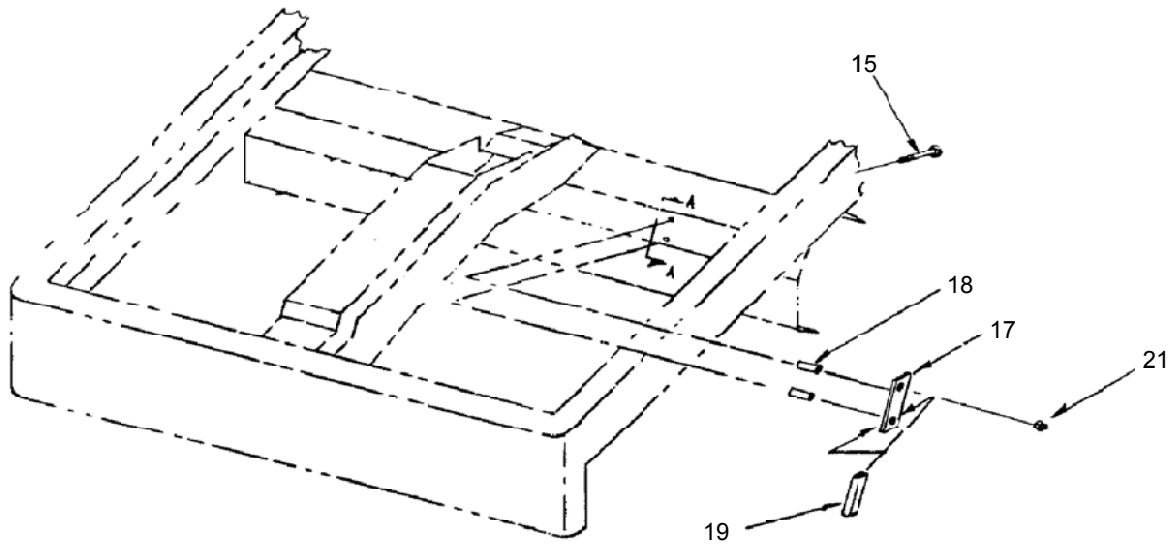
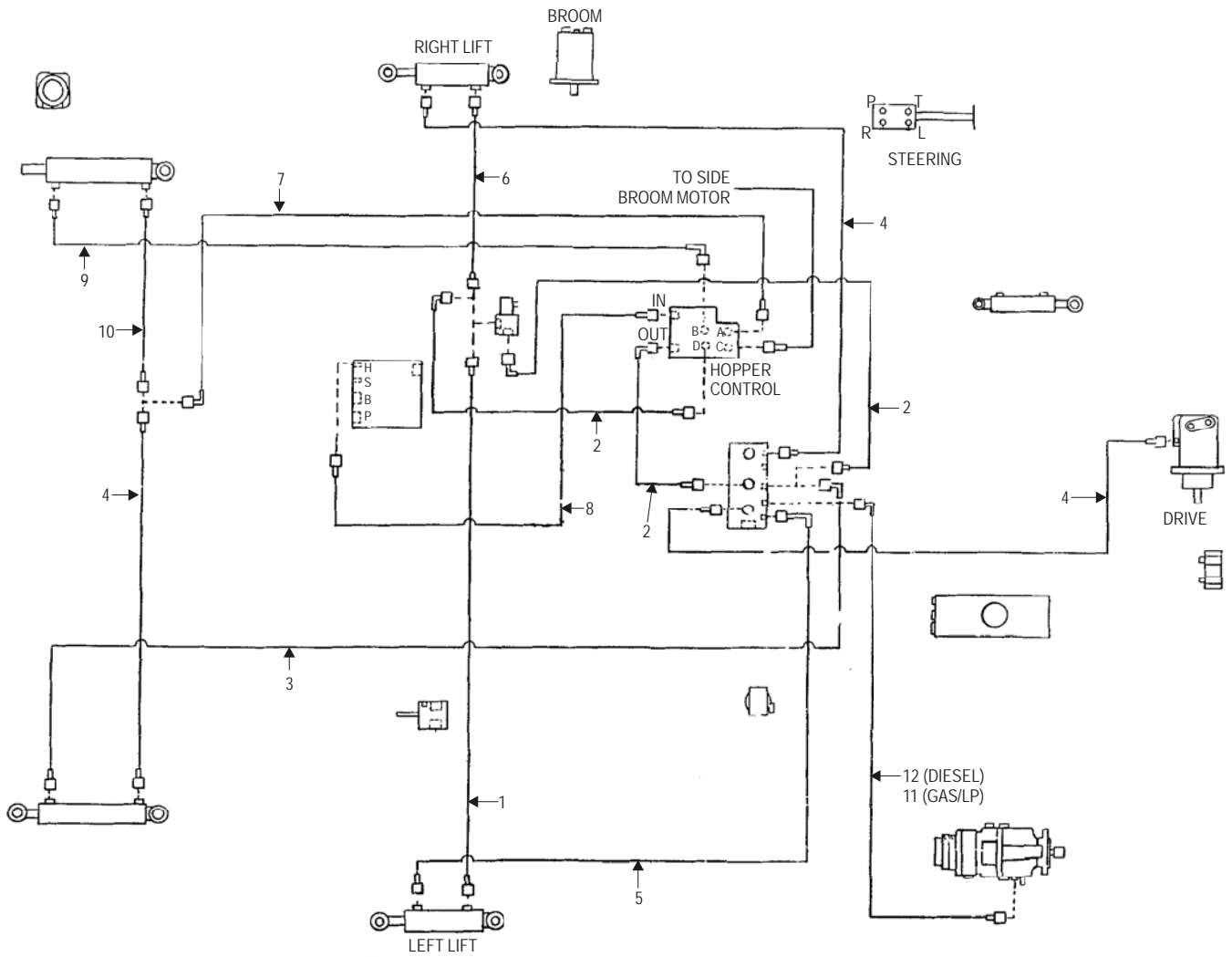

09-5	HYDRAULIC HOSE SYSTEM		
09-10	Granterra		91

Item	Ref. No.	Qty	Description
1*	8-33-02184	1	Hose, #4 x 50.5" -0-0-ORS-1WB
2*	7-33-02225	3	Hose, #4 x 38.0" -0-90-ORS-1WB
3*	8-33-02198	1	Hose, #4 x 107.0" -0-90-ORS-1WB
4*	8-33-02185	3	Hose, #4 x 56.0" -0-0-ORS-1WB
5*	7-33-02193	1	Hose, #4 x 49.0" -0-90-ORS-1WB
6*	8-33-02217	1	Hose, #4 x 32.0" -0-0-ORS-1WB
7*	8-33-02174	1	Hose, #4 x 16.5" -0-90-ORS-1WB
8	8-33-02178	REF	Hose, #4 x 15.0" -0-0-ORS-1WB
9*	8-33-02204	1	Hose, #4 x 76.0" -0-90-ORS-1WB
10*	8-33-02179	1	Hose, #4 x 46.0" -0-0-ORS-1WB
11	8-33-02329	1	Hose, #4 x 30.0" -0-0-90-ORS-1WB (Gasoline/LPG Only)
12	7-33-02225	1	Hose, #4 x 38.0" -0-90-ORS-1WB (Diesel Only)
15	2-00-00198	2	Bolt, 1/4-20 x 2.00 Carriage
17	8-65-00024	1	Clamp, Hydraulic Hose
18	7-75-01063	2	Spacer, .375 x .277 x 1.20
19	8-08-07045	2	Edging
21	2-00-00641	2	Nut, 1/4-20 Hex Fiber

*Part of Hose Kit 0860-753

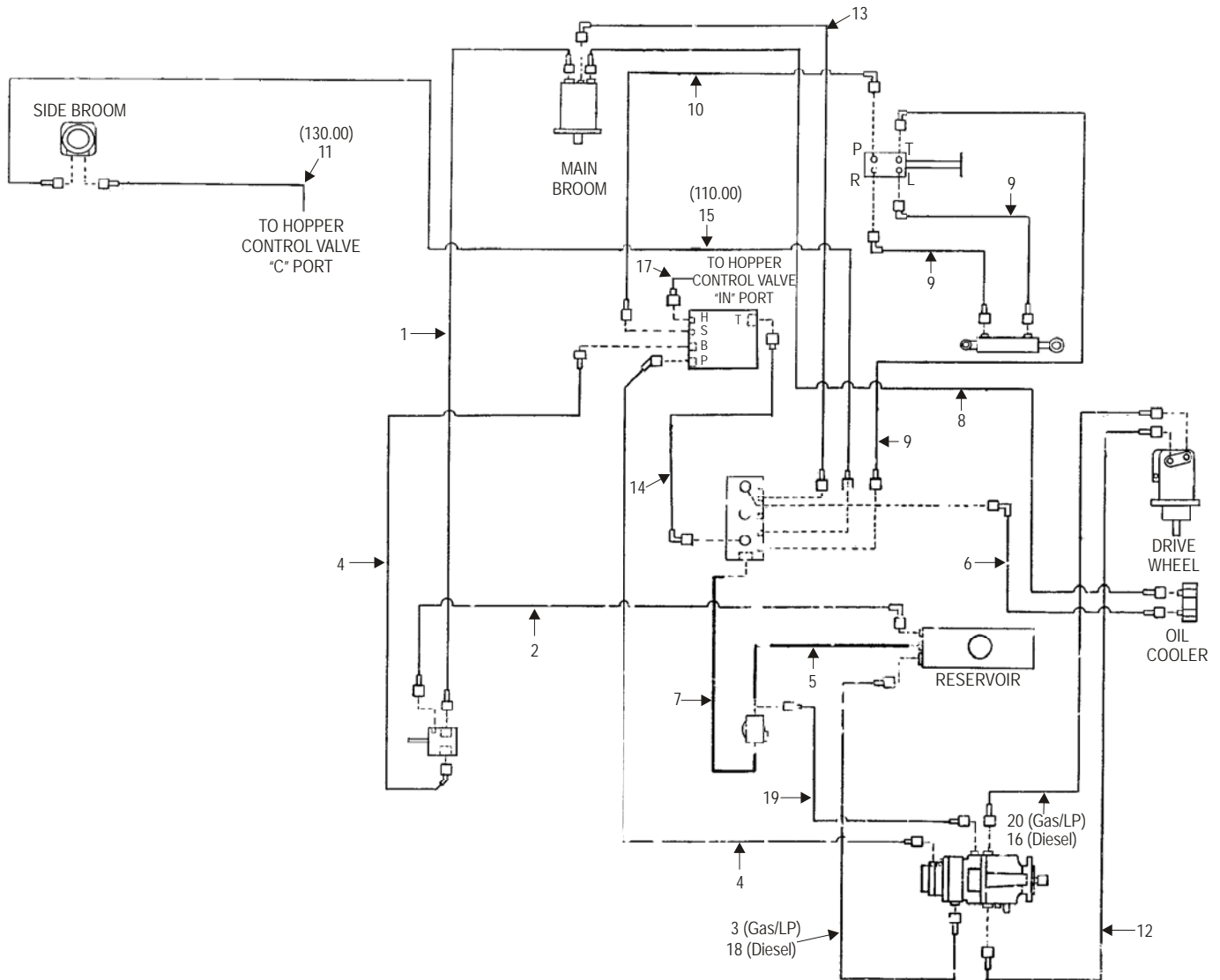

Item	Ref. No.	Qty	Description
1*<	8-33-02267	2	Hose, #8 x 62.0" -0-0-ORS-2WB
2*<	7-33-02189	1	Hose, #4 x 26.0" -0-90-ORS-1WB
3*	8-33-02215	1	Hose, #12 x 36.0" -0-0-ORS-1WB
4*<	8-33-02265	2	Hose, #8 x 23.0" -0-45-ORS-2WB
5	8-33-02273	1	Hose, 1 x 15.0" Return
6*<	8-33-02418	1	Hose, #8 x 52.0" -0-90-ORS-1WB
7	7-33-02317	1	Hose, 1 x 15.0" Return
8*<	7-33-02553	1	Hose, #8 x 90.0" -0-0-ORS-2WB
9*<	7-33-02190	3	Hose #4 x 67.0" -0-90-ORS-1WB
10*<	7-33-02200	1	Hose, #4 x 56.0" -0-90-ORS-1WB
11*<	8-33-02278	1	Hose, #4 x 130.0" -0-0-ORS-1WB
12*<	8-33-02195	1	Hose, #8 x 69.5" -0-0-ORS-2WB
13*<	7-33-02193	1	Hose, #4 x 49.0" -0-90-ORS-1WB
14*<	7-33-02206	1	Hose, #8 x 14.25" -0-90-ORS-1WB
15*<	8-33-02277	1	Hose, #4 x 110.0" -0-0-ORS-1WB
16<	8-33-02191	1	Hose, #8 x 56.5"-0-0-ORS-2 WB
17*<	8-33-02178	1	Hose, #4 x 15.0" -0-0-ORS-1WB
18<	8-33-02194	1	Hose, #12 x 32.0" -0-0-ORS-1WB
19*<	8-33-02217	1	Hose, #4 x 32.0" -0-0-ORS-1WB
20*	8-33-02196	1	Hose, #8 x 75.5" -0-0-ORS-2WB

*PART OF HOSE KIT 0860-755 (GAS/LP MODELS)

<PART OF HOSE KIT 0860-756 (DIESEL MODELS)

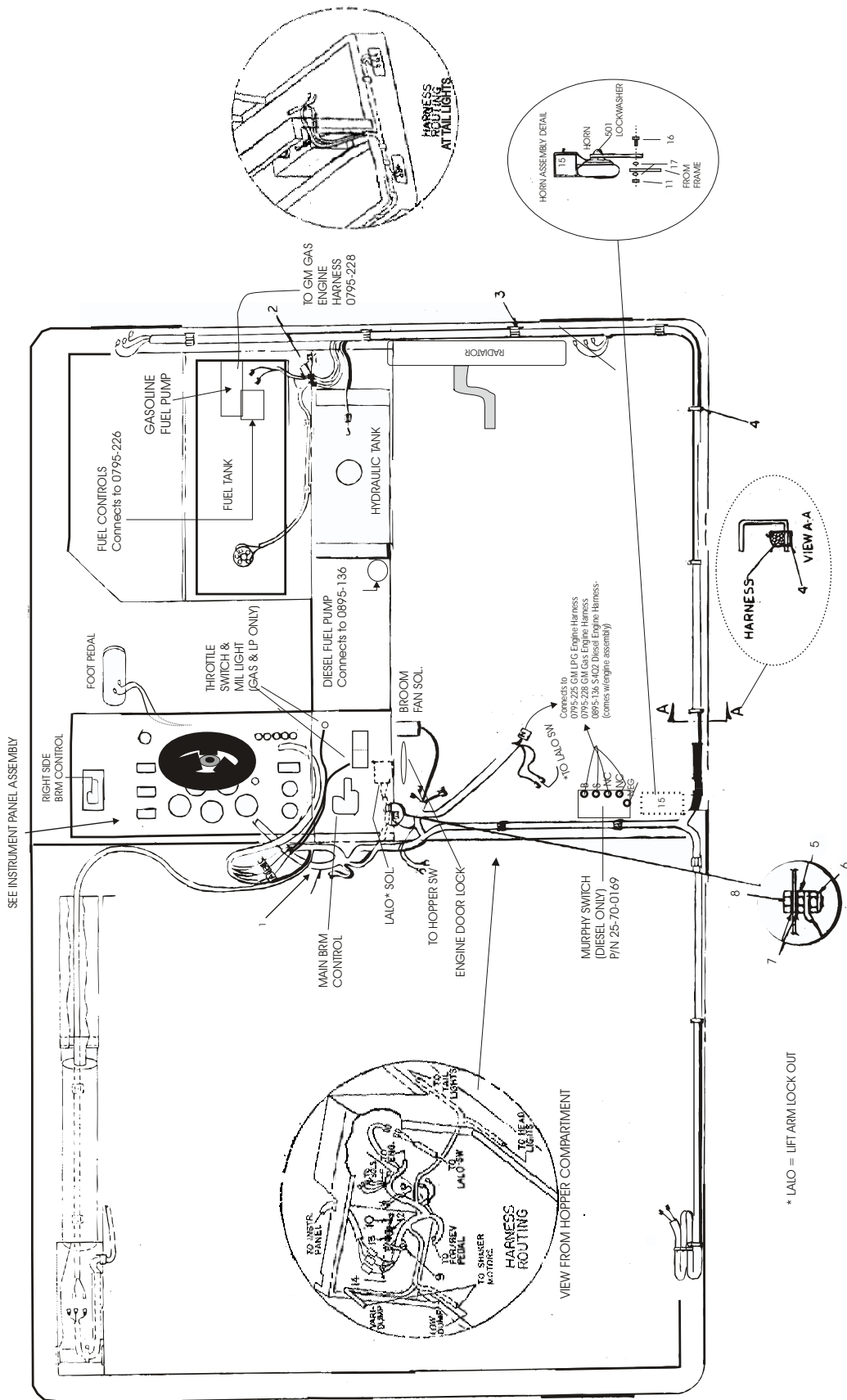

09-5	HARNES ROUTING - GAS/LP/DIESEL		
09-10	Granterra		95

Item	Ref. No.	Qty	Description
1	0895-131	1	Machine Harness
2	8-09-01081	2	Bushing, Snap
3	7-13-07096	17	Clamp, Adjustable
4	2-00-04345	5	Ty-Rap
5	2-00-00594	1	Nut, 1/4-20 Hex
6	2-00-00641	1	Nut, 1/4-20 Fiber Lock
7	2-00-00503	2	Washer, 1/4 Int. - Ext.
8	2-00-00205	1	Screw, 1/4-20 x 1.0 HHC
9	2-00-04937	1	Cable Tie
10	2-00-03063	1	Screw, 10-24 x 3/4 THM
11	2-00-00585	1	Nut, Hex 5/16-18 x .500 x .265
12	2-00-00519	1	Lock Washer, #10 Helical Spring
13	2-00-00605	1	Nut, #10-24 x .375 x .125 Hex
14	2-00-01246	1	Nut, #10-24 Fiber Lock
15	8-32-09013	1	Horn
16	2-00-00208	1	Screw, 5/16-18 x 3/4 HHC
17	2-00-02303	2	Lock Washer, 5/16
[]	7-90-07262	1	Battery Cable Negative
[]	8-90-07457	1	Battery Cable Positive (Gasoline/LPG only)
[]	8-90-07211	1	Battery Cable Positive (Diesel only)
[]	2-00-05171	1	Boot Positive
[]	2-00-05173	1	Battery Insulator
[]	0875-008	1	Battery Wet 12V (Maint. Free) (Gasoline/LPG only)
[]	0875-057	1	Battery Wet 12V (Maint. Free) (Diesel only)

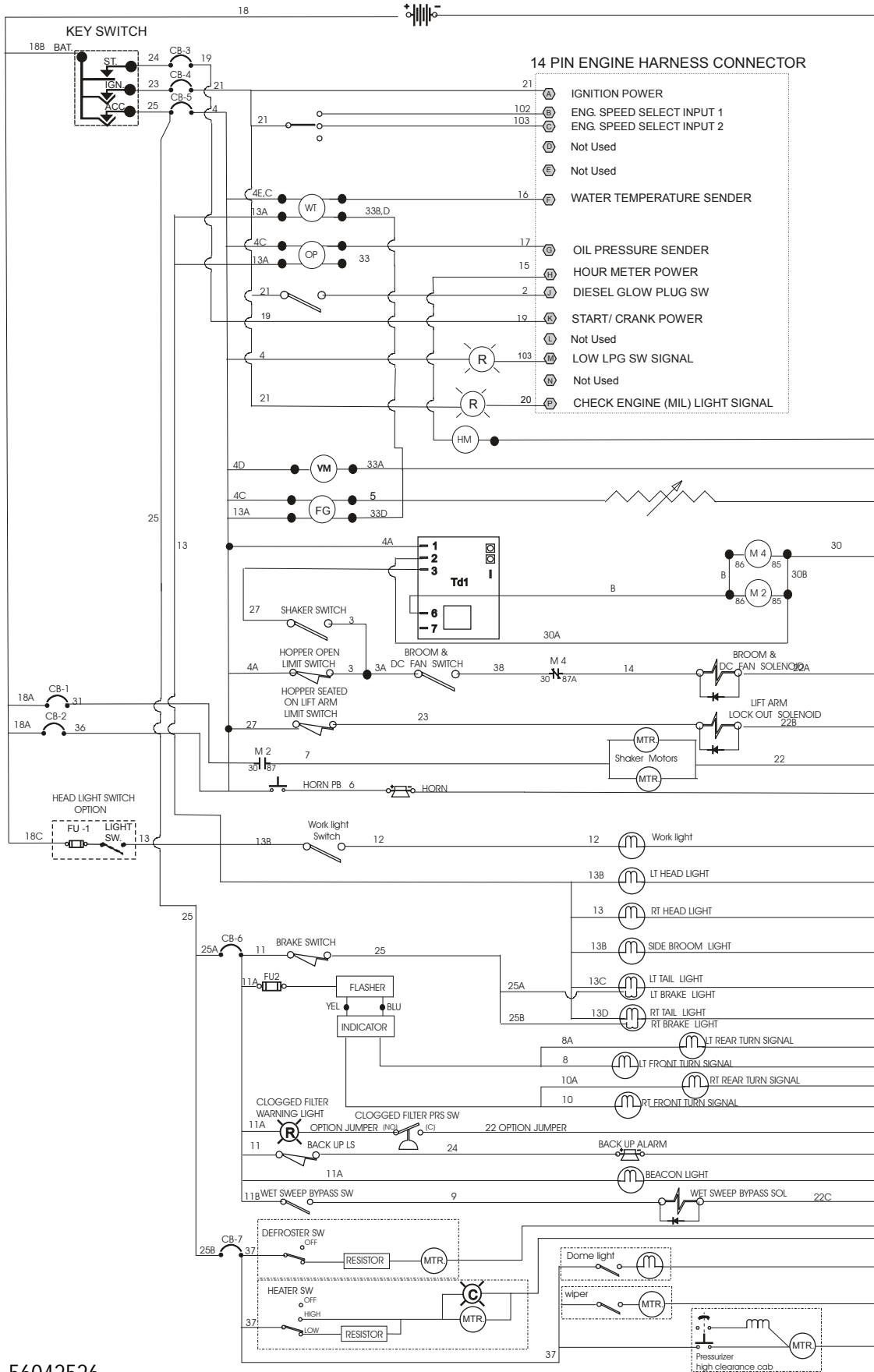

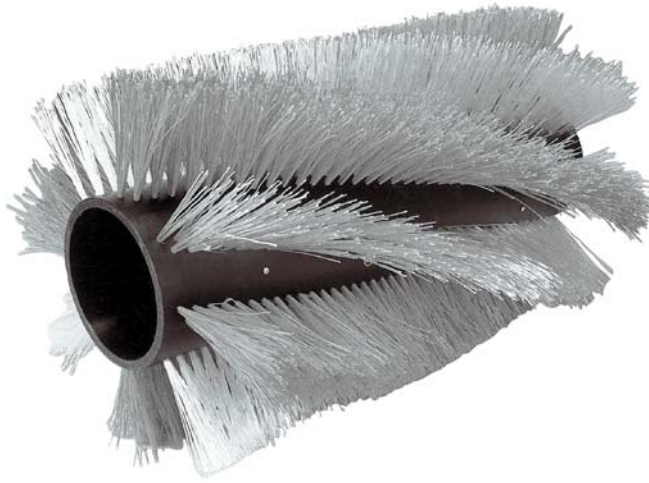
**Main Broom:****PN8-08-03202 Proex & Wire (STD.) (8 Double Rows)**

This broom has a more aggressive cleaning action, used to pick up heavier debris.

PN8-08-03207 Nylon (Optional) (8 Double Rows)

General purpose broom that can be used for all types of light soil. High wear material so uneven surfaces do not cause excessive wear. Nylon has a high heat deflection temperature, is chemical resistant and will absorb water in wet conditions. Truly a general purpose broom.

PN8-08-03204 Proex (Optional) (8 Double Rows)

Synthetic fiber made of polypropylene designed to pick up paper, gravel, sand and other lighter less bulky litter.

PN8-08-03210 High Density Fibre/Wire (Optional)

Fiber and wire bristles offer dust control from the natural vegetable fibers and a light cutting action from the crinkle wire. Designed for applications with fine dust and light compacted soilage.

PN8-08-03214 Polypropylene & Wire (Optional) (8 Double Row)**PN8-08-03209 Polypropylene (Optional) (8 Double Row)****8 Double Row**

Length.....50" (127 cm)

Diameter16" (40.6 cm)

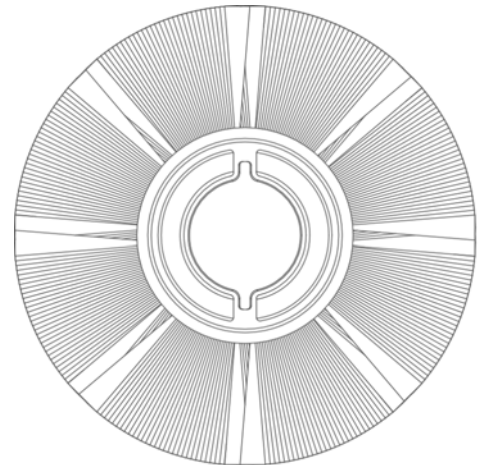
**Side Broom:****PN8-08-03211 Nylon (STD)**

The side broom function is to sweep the dirt and debris away from the curb, wall, pallet, etc. into the path of the main broom.

PN8-08-03212 Polypropylene (Optional)**PN0880-439 Wire Side Broom (Optional / broom and hardware)**

Diameter21" (53.34 cm)



Advance

14600 21st Avenue North
Plymouth, MN 55447-3408

www.advance-us.com

Phone: 800-989-2235

Fax: 800-989-6566

©2010 Nilfisk-Advance, Inc.

A Nilfisk-Advance Brand