

Exterra™

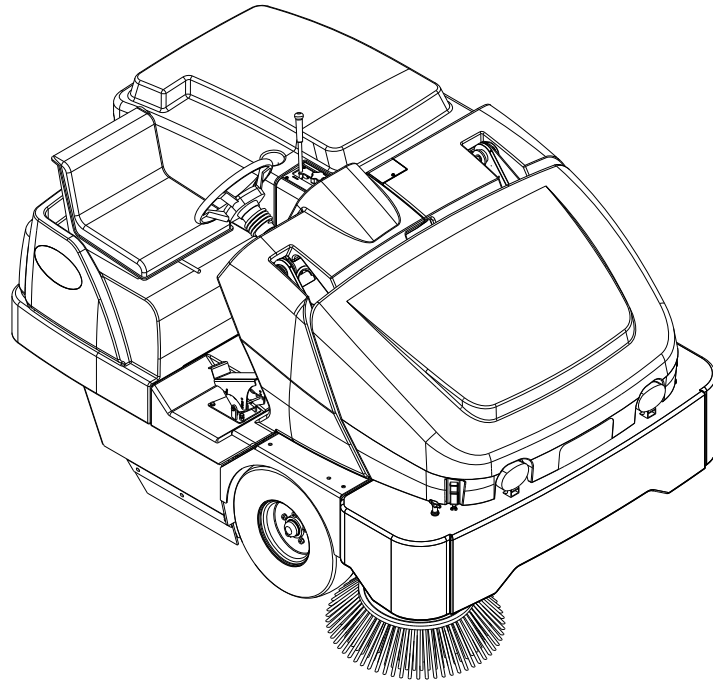

Quick Start Troubleshooting Manual

**Advance Models: 56507000 (3 cyl LPG), 56507001 (3 cyl Petrol)
56507003 (4 cyl LPG), 56507004 (4 cyl Petrol), 56507005 (4 cyl Diesel)**



Advance

by Nilfisk-Advance

10/07 revised 2/09 FORM NO. 56043110

TABLE OF CONTENTS

GENERAL INFORMATION	3-6
SAFETY INSTRUCTIONS	7
TECHNICAL SPECIFICATIONS	8-9
MAINTENANCE	10-13
PM CHECKLIST	14-15
KNOW YOUR MACHINE	16-21
OPERATOR'S COMPARTMENT	18
CONTROL PANEL	19
CONTROL PANEL DIAGNOSTICS	20-21
GENERAL MACHINE TROUBLESHOOTING GUIDE TABLE OF CONTENTS	22
ENGINE TROUBLESHOOTING FLOW CHARTS	23-33
WHEEL DRIVE SYSTEM	34
TROUBLESHOOTING CHECK LIST	34
STEERING SYSTEM	35
STEERING SYSTEM TROUBLESHOOTING OVERVIEW	35
TROUBLESHOOTING GUIDE	35
SWEEPING SYSTEM	36-44
MAIN BROOM	36-37
SIDE BROOMS	38-40
DUST CONTROL IMPELLER	41-42
SHAKER MOTOR	43-44
HOPPER SYSTEM	45-51
LIFT CYLINDER	45-46
DUMP DOOR CYLINDER	49-51
SOLUTION SYSTEM	52-53
MISTING PUMP	52-53
ENGINE SYSTEM	54-61
ENGINE SPECIFICATIONS	54-55
ENGINE MAINTENANCE	55
CHECK ENGINE LIGHT TROUBLESHOOTING	56
MISCELLANEOUS ENGINE SYSTEM INFORMATION	58
GM 1.6L GASOLINE FUEL SYSTEM DESCRIPTION	58
3 CYL KUBOTA REPLACEMENT OF THE ENGINE THROTTLE ACTUATOR	60-61
HYDRAULIC SYSTEM	62-71
HYDRAULIC SYSTEM TROUBLESHOOTING	62
GENERAL HYDRAULIC SPECIFICATIONS TABLE	63
HYDRAULIC TRUTH TABLE	64
MANIFOLD ASSEMBLY COMPONENTS	64-65
PRESSURE RELIEF VALVE	66
HYDRAULIC DIAGRAM	67-68
HYDRAULIC SYSTEM LAYOUT FOR OPTIONAL LEFT SIDE BROOM	69
HYDRAULIC COMPONENT LOCATION	71
HYDRAULIC SCHEMATIC	72-73
ELECTRICAL SYSTEM	74-87
ELECTRICAL COMPONENT LOCATION	74
WIRING DIAGRAM	75-77
WIRING SCHEMATIC	78-80
ENGINE HARNESS GM 1.6L GAS	81
ENGINE HARNESS GM 1.6L LPG	82
ENGINE WIRING HARNESS GM DETAIL	83
PROGRAMMABLE CONTROL OPTIONS	86-87

Note: All references to right, left, front, or rear in this manual are as seen from the operator's stand-point.

GENERAL INFORMATION

INTRODUCTION

This manual will help you get the most from your Advance rider Scrubber-Sweeper. Read it thoroughly before servicing the machine.

Note: Bold numbers and letters in parentheses and underlined indicate an item illustrated on pages 14-17 i.e. (B).

This product is intended for commercial use only.

PARTS AND SERVICE

Repairs, when required, should be performed by your Authorized Advance Service Center, who employs factory trained service personnel, and maintains an inventory of Advance original replacement parts and accessories.

Call the ADVANCE DEALER named below for repair parts or service. Please specify the Model and Serial Number when discussing your machine.

(Dealer, affix service sticker here.)

NAME PLATE

The Model Number and Serial Number of your machine are shown on the Nameplate on the machine. This information is needed when ordering repair parts for the machine. Use the space below to note the Model Number and Serial Number of your machine for future reference.

MODEL NUMBER _____

SERIAL NUMBER _____

HOPPER SAFETY SUPPORT

WARNING!

Make sure the Hopper Safety Support (**5**) is in place, by using the Hopper Safety Support Handle (**I**) whenever attempting to do any maintenance work under or near the raised hopper. The Hopper Safety Support (**5**) holds the hopper in the raised position to allow work to be performed under the hopper. NEVER rely on the machine's hydraulic components to safely support the hopper.

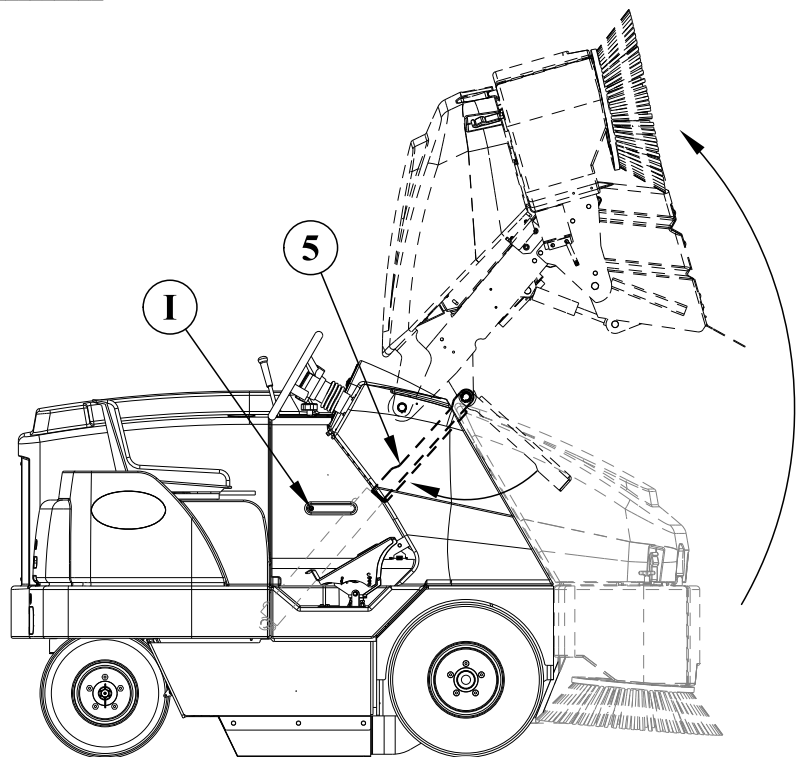

JACKING THE MACHINE

CAUTION!

Never work under a machine without safety stands or blocks to support the machine.

- When jacking the machine, do so at designated locations (Do Not jack on the hopper) – see jacking locations (**8**).

GENERAL INFORMATION

TRANSPORTING THE MACHINE

CAUTION!

Before transporting the machine on an open truck or trailer, make sure that . . .

- All access doors are latched securely.
- The machine is tied down securely - see tie-down locations **(26)**.
- The machine parking brake is set.

TOWING OR PUSHING A DISABLED MACHINE

CAUTION!

The machine's drive propelling pump is manufactured with an adjustable tow valve. This valve prevents damage to the hydraulic system when the machine is being towed/pushed short distances without use of the engine.

To access the valve; unlatch and open the Oil Reservoir / Fuel Tank Cover **(20)** and then open the Engine Compartment Cover **(1)** and locate the hydrostatic pump at the rear of the engine. The top half of the illustration on the following page shows the location on 3 cylinder models and the bottom half shows the 4 cylinder model location. Turn the valve 90 degrees, this disengages the hydrostatic lock between the motor and pump.

WARNING: The hydraulic propelling pump can be damaged if the machine is towed with the valve in the normal working position **(A)**. Reference the illustration on the following page for the normal working setting **(A)** (vertical) and the free wheeling towing setting **(B)** (horizontal). Note: If the tow valve is left in free wheeling **(B)** (horizontal) position the propelling pump can't drive the machine FWD or REV. No damage will result, just re-set valve to the normal working setting **(A)** (vertical). **NOTE:** Tow or push machine no faster than a normal walking pace (2-3 miles per hour) and for short distances only. If the machine is to be moved long distances the drive wheel needs to be raised off the floor and placed on a suitable transport dolly.

3 CYLINDER MODELS

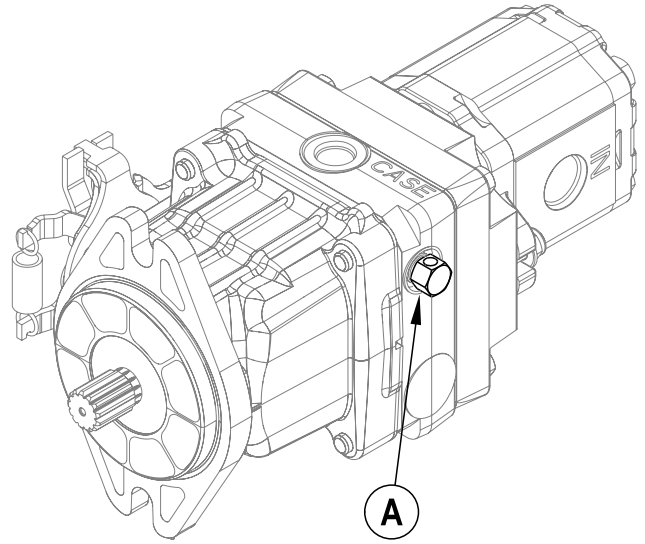
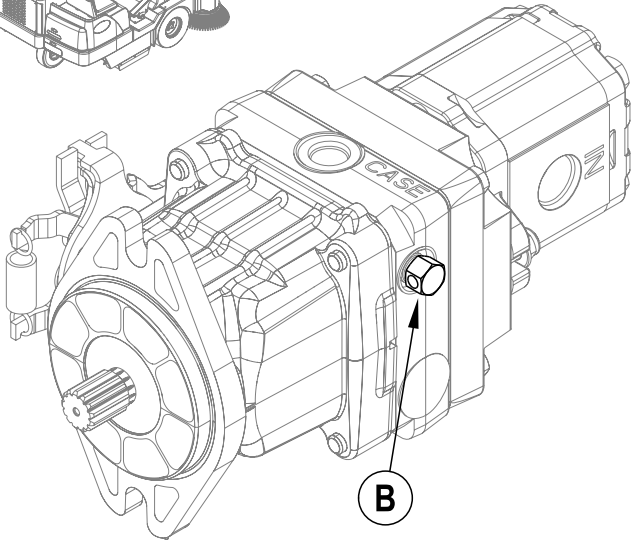
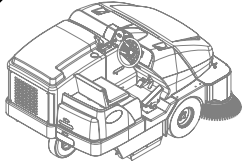

4 CYLINDER MODELS

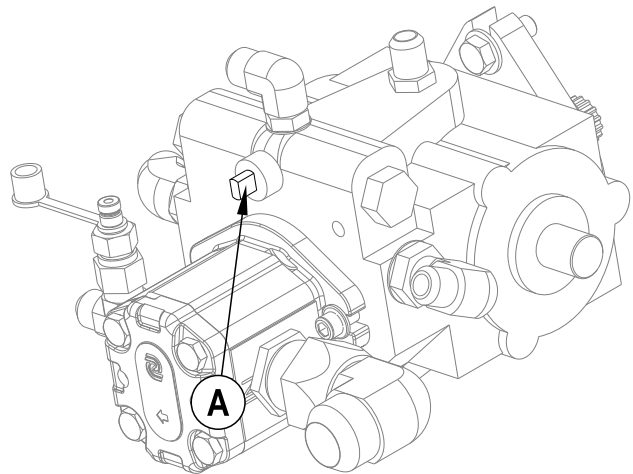
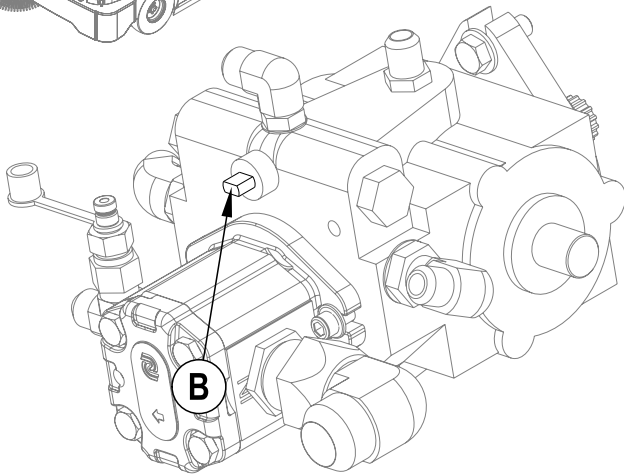
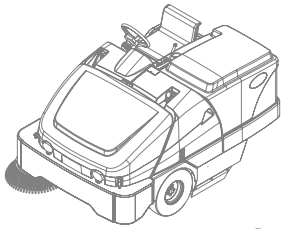

OTHER MANUALS AVAILABLE

The following manuals are available from the Advance Literature Service Department, for your Rider Scrubber/Sweeper:

- **General Information**
 - Advance website (www.advance-us.com)
 - EzParts service/parts CD-ROM
- **Parts List** - Form Number 56042471 (all systems w/optional kits & accessories)

- **Operation Manual** - Form Number 56041656 (English, Spanish)

- **Quick Start Troubleshooting Manual** 56043110
- **Cab Manuals**
 - Cab Addendum (Operator Manual) 56041710
 - Cab Addendum (Parts List) 56042486
 - Cab Addendum (Service Manual) 56043118
- **Engine Manuals**
 - 1.6L Industrial Engine Operator Manual (excerpt from 16LECSS) 56041564
 - 1.6L Industrial Engine Service Manual 36100009*
 - PSI Tier 2 1.6L PFI Certified Engine Service Manual G/LP PSI1P6LPFI-A*
 - 972DF Kubota Engine Service Manual (3 Cyl.) 97897-02670
 - 972DF Kubota Engine Operator Manual (3 Cyl.) EG561-8916-1
 - V1505 Kubota Diesel Engine Service Manual (WSM English) 97897-02432
 - V1505 Kubota Diesel Engine Service Manual (WSM English, French, German) 97897-01640
 - V1505 Kubota Diesel Engine Operator Manual (English, French, German, Italian, Spanish) 16622-8916-3

*Available in electronic format only

CAUTIONS AND WARNINGS

SYMBOLS

Advance uses the symbols below to signal potentially dangerous conditions. Always read this information carefully and take the necessary steps to protect personnel and property.

DANGER!

Is used to warn of immediate hazards that will cause severe personal injury or death.

WARNING!

Is used to call attention to a situation that could cause severe personal injury.

CAUTION!

Is used to call attention to a situation that could cause minor personal injury or damage to the machine or other property.



Read all instructions before using.

GENERAL SAFETY INSTRUCTIONS

Specific Cautions and Warnings are included to warn you of potential danger of machine damage or bodily harm.

DANGER!

- This machine emits exhaust gases (carbon monoxide) that can cause serious injury or death, always provide adequate ventilation when using machine.

WARNING!

- This machine shall be used only by properly trained and authorized persons.
- While on ramps or inclines, avoid sudden stops when loaded. Avoid abrupt sharp turns. Use low speed down hills. Clean only while ascending (driving up) the ramp.
- To avoid hydraulic oil injection or injury always wear appropriate clothing and eye protection when working with or near hydraulic system.
- Turn the key switch off (O) and disconnect the batteries before servicing electrical components.
- Never work under a machine without safety blocks or stands to support the machine.
- Do not dispense flammable cleaning agents, operate the machine on or near these agents, or operate in areas where flammable liquids exist.
- Only use the brooms provided with the appliance or those specified in the instructions for use manual. The use of other brooms may impair safety.

CAUTION!

- This machine is not approved for use on public paths or roads.
- This machine is only approved for hard surface use.
- This machine is not suitable for picking up hazardous dust.
- When operating this machine, ensure that third parties, particularly children, are not endangered.
- Before performing any service function, carefully read all instructions pertaining to that function.
- Do not leave the machine unattended without first turning the key switch off (O), removing the key and applying the parking brake.
- Turn the key switch off (O) and remove the key, before changing the brooms, and before opening any access panels.
- Take precautions to prevent hair, jewelry, or loose clothing from becoming caught in moving parts.
- Before use, all doors and hoods should be properly latched.
- Do not use on surfaces having a gradient exceeding that marked on the machine.
- All doors and covers are to be positioned as indicated in the instruction manual before using the machine.

SAVE THESE INSTRUCTIONS

TECHNICAL SPECIFICATIONS

General Specifications common to All Models

Dimensions

Length	93.75 inches (238cm)
Width (minimum)*	64.5 (164cm)
Height	58.5 inches (149cm)
Height w/overhead guard	81.25 inches (206cm)
Height w/cab	79 inches (201cm)
Ground clearance	3.1 inches (7.8cm)
Minimum ceiling height dumping clearance	101.4 inches (257.5cm)

Weights

Gross weight** 3 Cylinder	2700 lbs. (1224kg)
Gross weight** 4 Cylinder Diesel	3000 lbs. (1360kg)
Gross weight** GM 1.6L	3300 lbs. (1496kg)

Sweep System

Main broom length	50 inches (127cm)
Main broom diameter	14 inches (35.5cm)
Main broom bristle length	3.25 inches (8.26cm)
Sweeping path w/single side broom	65 inches (165cm)
Sweeping path w/dual side brooms	77 inches (196cm)
Side broom diameter (STD)	24 inches (61cm)
Side broom bristle length	6 inches (15.2cm)

Hopper System

Capacity	14 ft ³ (396L)
Lifting capacity	1000 lbs. (454kg)
Dump height (variable)	Max. 60 inches (152cm)
Dump height with door open	52.75 inches (134cm)

Dust Control System

Filter type: Pleated paper panel STD (optional poly filter available)	
Filter media area	88 ft ² (8.17m ²)
Filter dimension	3.19" x 18" x 30" (8.1cm x 45.7cm x 76.2cm)
Dust Guard Water Misting Tank Capacity	14 gal. (53L)

Steering System

Type: Full power steering unit and hydraulic cylinder	
Turn radius left	95" (242cm)
Turn radius right	63" (160cm)
Minimum aisle turn width (left)	109 in. (277cm)

Hydraulic System

Oil type: SAE 10W-30 (fill to bottom of screen)	
System fill capacity	11 gal. (41.6L)

Engine System

Diesel & Petrol (gasoline) fuel tank capacity	12.5 gal. (47.3L)
---	-------------------

Tires

Tire pressure (all 3)	90-100 PSI
-----------------------	------------

***Width (minimum):** Width of machine body at the hopper, no side brooms.

****Gross Weight:** Standard machine without options, with 175 lbs. operator, with standard sweeping brooms and full tank of fuel.

TECHNICAL SPECIFICATIONS

Specifications common to Engine Size

English (Metric)

	3 Cylinder models	4 Cylinder models
Sound Level		
At operators ear	81 dBA	83 dBA
Speed and Gradeability		
Maximum grade angle (transport)	20% / 11°	25% / 14°
Maximum grade angle (sweeping)	15% / 8°	25% / 14°
Maximum trailer loading angle (all models)	19.4°	
Travel speed (Maximum)	8.5 mph (13.5km/h)	9 mph (14.5km/h)
Maximum reverse speed (all models)	5.5 mph (8.8km/h)	

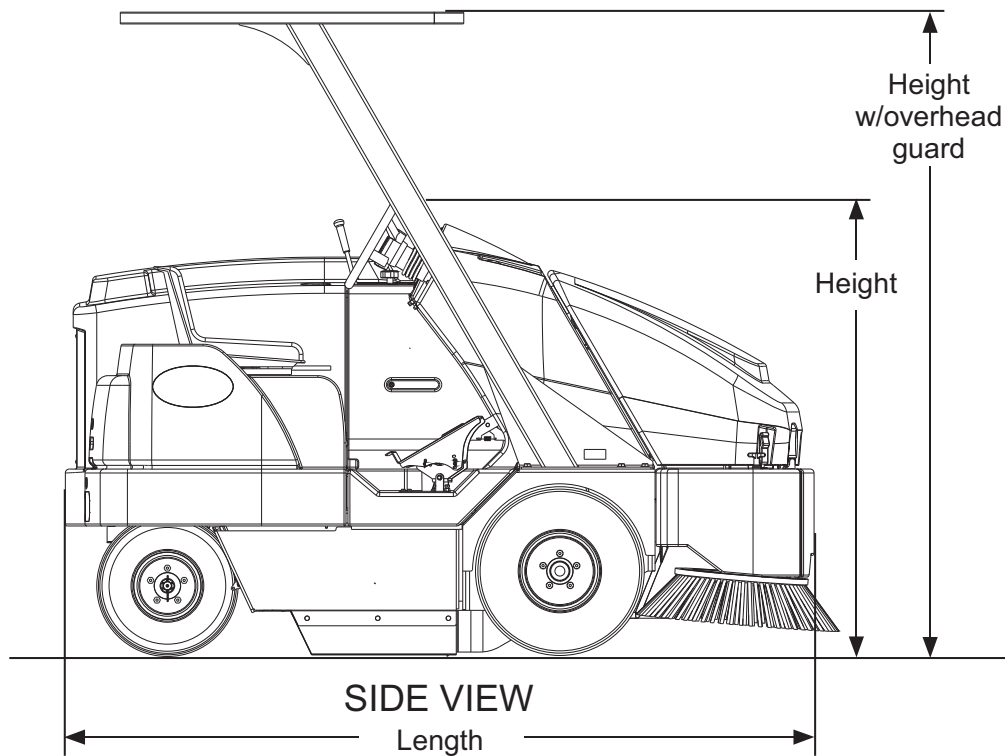
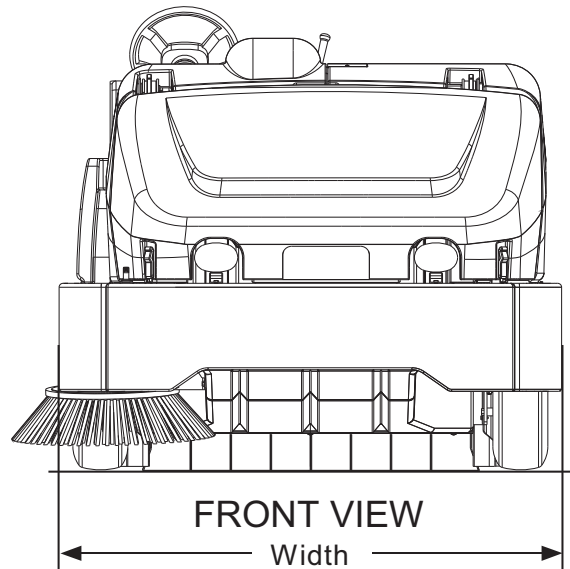

MAINTENANCE

MAINTENANCE SCHEDULE

Maintenance intervals given are for average operating conditions. Machines used in severe operational environments may require service more often.

MAINTENANCE ITEM	PERFORM DAILY				
Perform the "After Use" maintenance steps	X				
Check parking brake	X				
Check engine oil	X				
*Clean main and side broom(s)	X				
Check engine air filter indicator	X				
Check engine coolant level	X				
Check hydraulic oil level	X				
MAINTENANCE ITEM	15 hrs.	30 hrs.	150 hrs.	300 hrs.	1000 hrs.
*Rotate main broom	X				
*Inspect/adjust brooms		X			
* Check / Clean Hopper Dust Control Filter Using Method "A"		X			
*Inspect broom housing skirts		X			
*Inspect hopper seals		X			
Clean radiator and oil cooler		X			
Perform engine maintenance			X		
*Inspect and grease steering spindle			X		
* Check / Clean Hopper Dust Control Filter Using Method "B"			X		
* Check / Clean Hopper Dust Control Filter Using Method "C"				X	
Change the hydraulic "charge" oil filter					X
Change reservoir hydraulic oil					X
Flush the radiator					X
All engine fuel filter(s)					X**

*See the Mechanical Repair section and Operator Manual for detailed maintenance information of systems listed. (Sweeping, Hopper, Steering & Dust Control)

**Fuel filters replacement: 400 hrs or yearly. Reference the Parts List for engine type and filter part number.

AFTER USE

- 1 Shake the Hopper Dust Control Filter (**LL**) and empty the hopper.
- 2 Check the maintenance schedule and perform all required maintenance before storage.
- 3 Move the machine to an indoor storage area.
- 4 Shut down the engine according to the shut down procedures.
- 5 Make sure the Ignition Switch (**IT**) is OFF and the Parking Brake (**E**) is engaged.

NOTE: It is safe to clean this machine with a pressure washer as long as you do not spray directly at or into electrical components. The machine should always be allowed to dry completely before each use.

TO SHUT DOWN THE DIESEL / GASOLINE ENGINE

- 1 Turn all controls to the OFF position.
- 2 Raise the brooms.
- 3 Place the Engine Speed Switch (**GG**) in IDLE and let the engine idle for 25 - 30 seconds.
- 4 Turn the Ignition Key Switch (**IT**) OFF and remove the key.
- 5 Apply the Parking Brake (**E**).

TO SHUT DOWN THE PROPANE ENGINE

- 1 Turn all controls to the OFF position.
- 2 Raise the brooms.
- 3 Turn the service valve on PROPANE Tank (**21**) OFF.
- 4 Run the engine until all the PROPANE is dispelled from the line (the engine will stall).
- 5 Turn the Ignition Key Switch (**IT**) OFF and remove the key. **NOTE:** The 4 cylinder LPG engine will continue to run for a few seconds after switching the key to off. This is part of the proper operation of the closed loop electronic control system.
- 6 Apply the Parking Brake (**E**).

MAINTENANCE

IMPORTANT MACHINE LUBRICATION

Rear Steering Yoke Bearing Assembly

Once every 150 hours attach a grease gun to the yoke bearing pivot zert (location under operator's seat) and pump a small amount of grease into bearing assembly.

Also every 150 hours apply light machine oil to maintain free movement of all general pivot points. Example the seat, and broom door hinges etc. Broom and hopper pivots use composite bearings lubrication is not required.

WARNING

For the protection of the environment; when servicing any of the machine's lubrication fluids they must be disposed of safely in accordance with your local environmental regulations (recycling). Examples of machine lubrication products: **(Engine crankcase oil, Engine crankcase oil filter, Hydraulic system oil, Hydraulic system oil filters).**

ENGINE COOLANT

CAUTION!

Do not remove the radiator cap when the engine is hot.

To check the engine coolant level, first unlatch and open the Oil Reservoir / Fuel Tank Cover **(20)** then lift the Engine Compartment Cover **(1)** and observe the coolant level on the Coolant Recovery Tank **(15)** or **(22)**. If the level is low add a mixture of half water and automotive type anti-freeze. Clean the radiator and oil cooler exteriors by washing with low-pressure water or using compressed air every 30 hours. Service Note: The oil cooler tips out for easy cleaning.

ENGINE OIL – GASOLINE (PETROL) & LPG

Check the engine oil level when the machine is parked on a level surface and the engine is cool. Change the engine oil after the first 35 hours of operation and every 150 hours after that. Use any SF or SG rated oil meeting API specifications and suited to seasonal temperatures. Refer to the Engine System section for oil capacities and additional engine specifications. Replace the oil filter with every oil change.

TEMPERATURE RANGE

Above 60° F (15° C)

Below 60° F (15° C)

OIL WEIGHT

SAE 10W-30

SAE 5W-30

ENGINE OIL - DIESEL

Check the engine oil level when the machine is parked on a level surface and the engine is cool. Change the engine oil after the first 35 hours of operation and every 150 hours after that. Use CF, CF-4 or CG-4 oil meeting API specifications and suited temperatures (*important reference the oil/fuel type note below for further diesel oil recommendations). Refer to the Engine System section for oil capacities and additional engine specifications. Replace the oil filter with every oil change.

TEMPERATURE RANGE

Above 77 °F (25 °C)

32 °F to 77 °F (0 °C to 25 °C)

Below 32 °F (0 °C)

OIL WEIGHT

SAE 30 or 10W-30

SAE 20 or 10W-30

SAE 10W or 10W-30

* Diesel Lubricating Oil Note:

With the emission control now in effect, the CF-4 and CG-4 lubricating oils have been developed for use of a low-sulfur fuel on-road vehicle engines. When an off-road vehicle engine runs on a high-sulfur fuel, it is advisable to employ the CF, CD or CE lubricating oil with a high total base number. If the CF-4 or CG-4 lubricating oil is used with a high-sulfur fuel, change the lubricating oil at shorter intervals.

- Lubricating oil recommended when a low-sulfur or high-sulfur fuel is employed.

Lubricating Oil class	Fuel	Low sulfur (0.5 % ≥)	High sulfur	Remarks
	CF		O	O
CF-4		O	X	
CG-4		O	X	

O : Recommendable

X : Not recommendable

MAINTENANCE

ENGINE AIR FILTER

The engine Air Filter (24) is located in the engine compartment. Check the air mechanical vacuum filter Service Indicator (27) before each use of the machine. Do not service the air filter unless the indicator is shown (red).

CAUTION!

When servicing the engine air filter elements, use extreme caution to prevent dust and dirt from entering the engine.

The engine air filter contains a primary (outer) and a safety (inner) filter element. The primary element may be cleaned twice before being replaced. Replace the safety element every third time that the primary element is serviced. Never try to clean the safety element. To clean the primary filter element, remove the cover from the dust cup end of the canister and pull out the primary element. Clean the element with compressed air (maximum pressure 100 PSI) or wash it with water (maximum pressure 40 PSI). Do not put the element back into the canister until it is completely dry.

Special Service Note: Inspect the complete air intake system for proper routing (kinks & restrictions) and sound tight connections. The mechanic should run their hand around the air intake hoses to check for any cracks and holes that will allow non-filtered air to enter the engine that will severely shorten the engine's useful life.

ENGINE MAINTENANCE (150 HOURS)

At 150 hour intervals it is recommended that the following service be performed: Change oil and filter, clean and inspect spark plugs, check all engine belts condition and adjustment, check battery charge and level, check cooling system hoses and clamps and check general condition and performance of engine.

Note: Reference the separately supplied PSI GM Power Train Products Operation and Maintenance manual for more detailed service data. See the "Other Manuals Available" section for a complete list of the engine manuals that are available.

SPECIAL LIQUID PROPANE FUEL SYSTEM MAINTENANCE ON THE GM 1.6L ENGINE

Every 150 hours inspect and drain any oil build up from the LP fuel system electronic pressure regulator (EPR). During the course of normal operation oils or "heavy ends" may build inside the chambers of the propane regulator. These oils and heavy ends may be a result of poor fuel quality, contamination of the fuel supply chain, or regional variation in the make up of the fuel. If the build up of the oil is significant this can affect the function of the fuel control system. Note: Reference the Tier 2 PSI 1.6l PFI certified engine service manual form # PSI1P6LPFI-A, and follow the procedure to drain the EPR regulator.

MAINTENANCE HYDRAULIC OIL

WARNING!

To avoid hydraulic oil injection or injury, always wear appropriate clothing and eye protection when working with or near hydraulic system.

Check the Hydraulic Oil Level. Unlatch and swing open the Oil Reservoir / Fuel tank Cover (20). Remove the reservoir cap to check the oil level. The hydraulic oil level should be half way up the screen filter inside the filler neck of the reservoir. Add SAE 10W30 motor oil if it is below this level. Change the oil if major contamination from a mechanical failure occurs.

Change the Hydraulic "Charge" Oil Filter once a year or every 1000 hours.

HOPPER DUST CONTROL FILTER (PANEL FILTER)

The hopper dust control filter must be cleaned regularly to maintain the efficiency of the vacuum system. Follow the recommended filter service intervals for the longest filter life.

CAUTION!

Wear safety glasses when cleaning the filter.

Do not puncture the paper filter.

Clean the filter in a well-ventilated area.

Wear appropriate dust mask to avoid breathing in dust.

To remove the hopper dust control filter...

- 1 Unlatch and open the Hopper Cover (16). Make sure that the Hopper Cover Prop Rod (17) is in place.
- 2 Inspect the top of the Hopper Dust Control Filter (12) for damage. A large amount of dust on top of the filter is usually caused by a hole in the filter or a damaged filter gasket.
- 3 Unthread and remove the four Shaker Assembly Retainer Knobs (13). Lift off the Dust Filter Shaker Assembly (11) to access the panel filter.
- 4 Lift the Hopper Dust Control Filter (12) out of the machine.
- 5 **Clean the filter using one of the methods below:**

Method "A"

Vacuum loose dust from the filter. Then **gently** tap the filter against a flat surface (with the dirty side down) to remove loose dust and dirt.

Method "B"

Vacuum loose dust from the filter. Then blow compressed air (maximum pressure 100 psi) into the clean side of the filter (in the opposite direction of the airflow).

Method "C"

Vacuum loose dust from the filter. Then soak the filter in warm water for 15 minutes, then rinse it under a gentle stream of water (maximum pressure 40 psi). Let the filter dry completely before putting it back into the machine.

- 6 Follow the instructions in reverse order to install the filter. If the gasket on the filter is torn or missing, it must be replaced. **NOTE:** Before replacing filter clear debris from dust plate located under filter. Verify that the debris flap at the rear of the dust plate swings freely

HOPPER DUST CONTROL FILTER (OPTIONAL NILFISK POCKET FILTER SYSTEM)

The optional Nilfisk pocket filter system is basically maintenance free. The only periodic maintenance required by the machine operator is to run the Shaker (LL) on a daily basis. **NOTE:** The shaker should only be run with the hopper in the down position.

Exterra PM Checklist

Customer _____

Address _____

City _____ St _____ Zip _____

Model _____ Serial _____ Hours _____

Defect Codes

- A** needs adjustment
- B** binding
- C** dirty or contaminated
- D** damaged, bent or torn
- L** leaks
- M** missing
- W** worn out

Ref	OPERATIONAL INSPECTION ITEMS	OK	Defect Codes (circle)	Does Not Work
1	Check Neutral Safety/Sense Switch operation (To test depress drive pedal and start the engine, it should not start.)		A B C	
2	Engine Starting with pedal in neutral (if it will not start check sensor switch programming)		starts hard	
3	Engine Speeds 3 cyl G/P (note electrical actuator throttle linkage 1500 - 2800 RPM)		A rough	
4	Engine Speeds 4 cyl G/P (1200 - 2400 RPM)		A low power	
5	Engine Speeds Diesel (note electrical actuator linkage 1200 - 2400 RPM)			
6	Drive Pedal Linkage (check for FWD/REV drive and any neutral creep)		A B	
7	Drive System Performance		noisy sluggish	
8	Brakes (check both service & parking)		A B W	
9	Steering		excessive play	
10	Hopper Up/Down (also check operation of the safety hopper support)		A B	
11	Hopper Dump Door Open/Close		A B	
12	Main Broom Raise /Lower		<---->	
13	Side Broom Raise /Lower		<---->	
14	Main Broom On/Off		<---->	
15	Side Broom On/Off		<---->	
16	Headlights, Gauges and Optional Accessories (example rotating beacon, backup alarm)			
17	Dust Control Filter Shaker & Vacuum Impeller		<---->	
18	Tilt Steering Mechanism and Seat Adjustment lever		A B	
19	Dust Guard (OPT) Water Pump Operation On/Off			

Ref	VISUAL INSPECTION ITEMS	Comments	OK	Defect Codes (circle)	Does Not Work
20	Side Broom Pattern & Height Adj. (min bristle wear 3 inches)	3 O'clock to 11		A B D W	
21	Side Broom Motor			B L	
22	Hopper Cover Gasket			D W	
23	Hopper Dust Filter & Gasket			D W	
24	Dust Control Vacuum Impeller Motor			L	
25	Hopper Dump Door Cylinder			A B L	
26	Hopper Skirting & Seals (raise hopper to inspect)			D M W	
27	Hopper Dump Door & Seal (raise hopper to inspect)			A B D W	
28	Hopper Lift Cylinder & Hopper Interlock Switch	Magnetic Switch		A B L	
29	Main Broom Pattern Adjustment (min bristle wear 2-1/2" 6.4cm length)	2-3" (5-7 cm) wide pattern		A B D W	
30	Main Broom Motor (open left side access door to inspect)			B L	
31	Broom Housing & Door Skirts			D M W	
32	Front tires (check lug nut torque 80FT LB, 108 Nm)	Tire Pressure 90 psi		L W	
33	Battery	Clean & Water		C W	
34	Engine Air Cleaner Element (inner & outer)	Check SVR Indicator		C W	

Ref	VISUAL INSPECTION ITEMS (continued)	Comments	OK	Defect Codes (circle)	Does Not Work
35	Circuit Breaker/Relay panel (inspect electrical connections)			C D	
36	Hydrostatic Dump Valve	Tow Valve		B	
37	Hopper Up Transport Speed control Cam/Cable Linkage			A B	
38	Propulsion drive & Accessory Pumps			L	
39	Hydraulic Reservoir, System Hoses & fittings			L	
40	Propulsion Pump Hydro Back Cable & Clevis Connections			B M W	
41	Engine, Oil Level, Hoses & Belts			Add or Change L W	
42	Engine Coolant Level			L Add Coolant	
43	Radiator & Oil Cooler Core Blockage			L Needs Cleaning	
44	Hydraulic Oil Reservoir Level (10W-30 engine oil only)	Bottom of Screen		L Add Oil	
45	Hydraulic Oil Filter	SVR Life 1000 Hrs		L Replace	
46	Steer Spindle & Drive Wheel motor (open operator's seat)	Grease Spindle Zert		D L	
47	Rear Tire (check lug nut torque 100 FT LB, 135Nm)	Tire Pressure 90 psi		L M W	
48	Gasoline/Diesel tank , Filter & Lines			C L	
49	LP Tank, Hoses & Fittings			L	
50	LP Fuel Filter	SVR Life 1500 Hrs		L Replace	
51	LP Fuel Regulator, Lock Off Valve & Hoses			L	
52	Diesel Glow Plug Indicator Light	Hard Starting		Replace	
53	Diesel Fuel Filter			L Replace	
54	Engine Air-Intake Hose Assembly (air inlet to engine)	clamp fittings / Holes		C L	
55	Dust Guard Water Tank, Misting Pump & Storage Tank				

NOTE: For additional service information see service manual form number 56043110 and operators manual form number 56041656 (English & Spanish).

Defect Codes	A	needs adjustment	C	dirty or contaminated	M	missing
	B	binding	D	damaged, bent or torn	W	worn out
			L	leaks		

WORK COMPLETED BY: _____

ACKNOWLEDGED BY: _____

Service Technician Signature

Date

Customer Signature

Date

KNOW YOUR MACHINE

As you read this manual, you will occasionally run across a bold number in parentheses and underlined - example: **(2)**. These numbers refer to an item on the next four pages. Refer back to these pages whenever necessary to pinpoint the location of an item mentioned in the text.

- 1 Engine Compartment Cover
- 2 Left Side Main Broom Access Panel
- 3 Battery
- 4 Center Cover Assembly
- 5 Hopper Safety Support
- 6 Hopper Cover Latch
- 7 Head Light
- 8 Jacking Locations (rear location is large weight below radiator)
- 9 Side Broom
- 10 Side Broom Height Adjustment Knob
- 11 Dust Filter Shaker Assembly
- 12 Hopper Dust Control Filter
- 13 Shaker Assembly Retainer Knobs
- 14 Hydraulic Oil Filter
- 15 Coolant Recovery Tank (4 cylinder location)

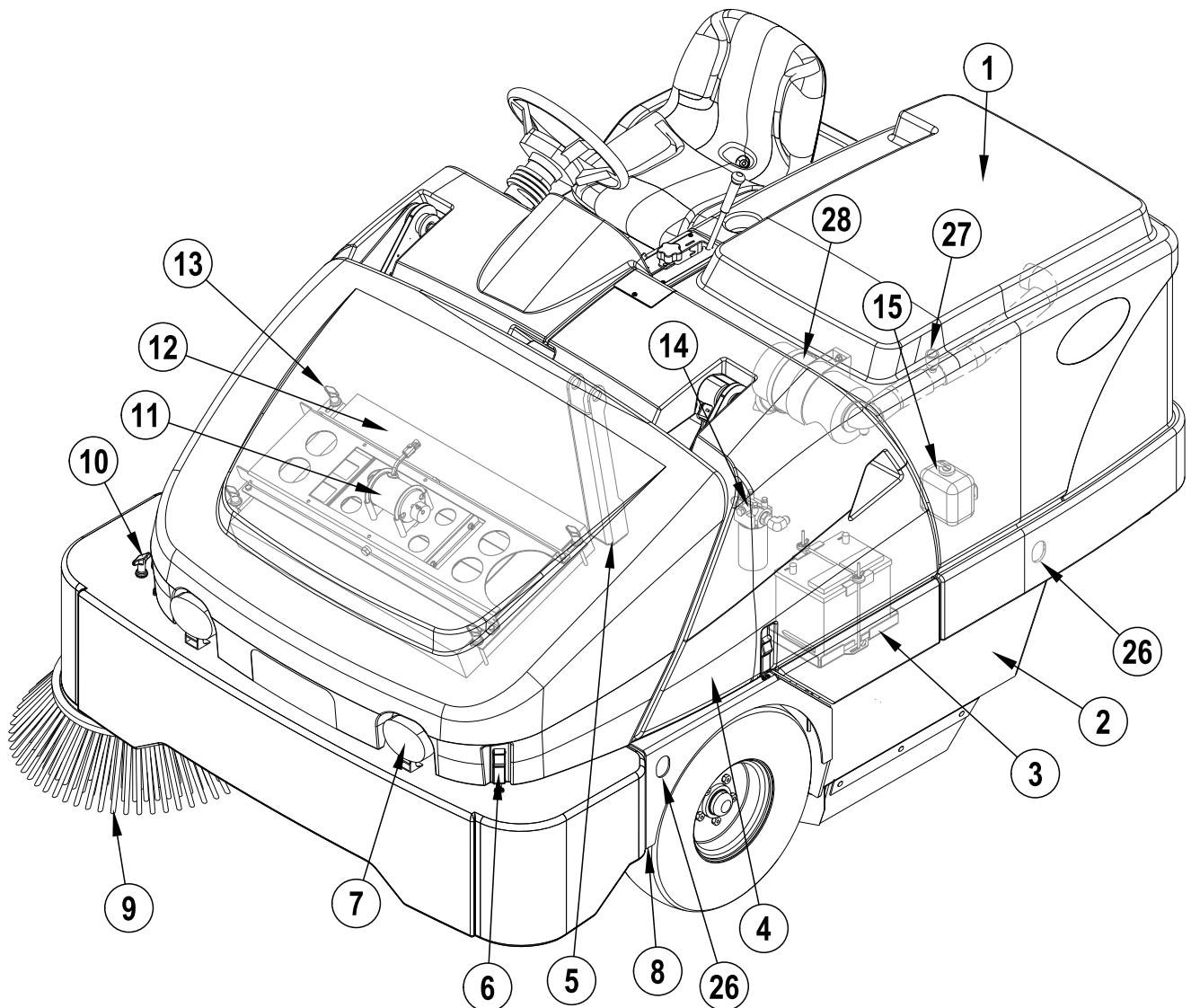

KNOW YOUR MACHINE (CONTINUED)

- 16 Hopper Cover
- 17 Hopper Cover Prop Rod
- 18 Right Side Main Broom Access Panel
- 19 Oil Reservoir
- 20 Oil Reservoir / Fuel Tank Cover
- 21 Fuel Tank (LPG tank shown / Gasoline tank is in same location)
- 22 Coolant Recovery Tank (3 cylinder & diesel location)
- 23 Radiator Cap
- 24 Engine Air Filter (3 cylinder & diesel location)
- 25 Fuel Tank Cover Release Latch
- 26 Tie-Down Locations (5)
- 27 Air Filter Service Indicator
- 28 Engine Air Filter (4 cylinder location)

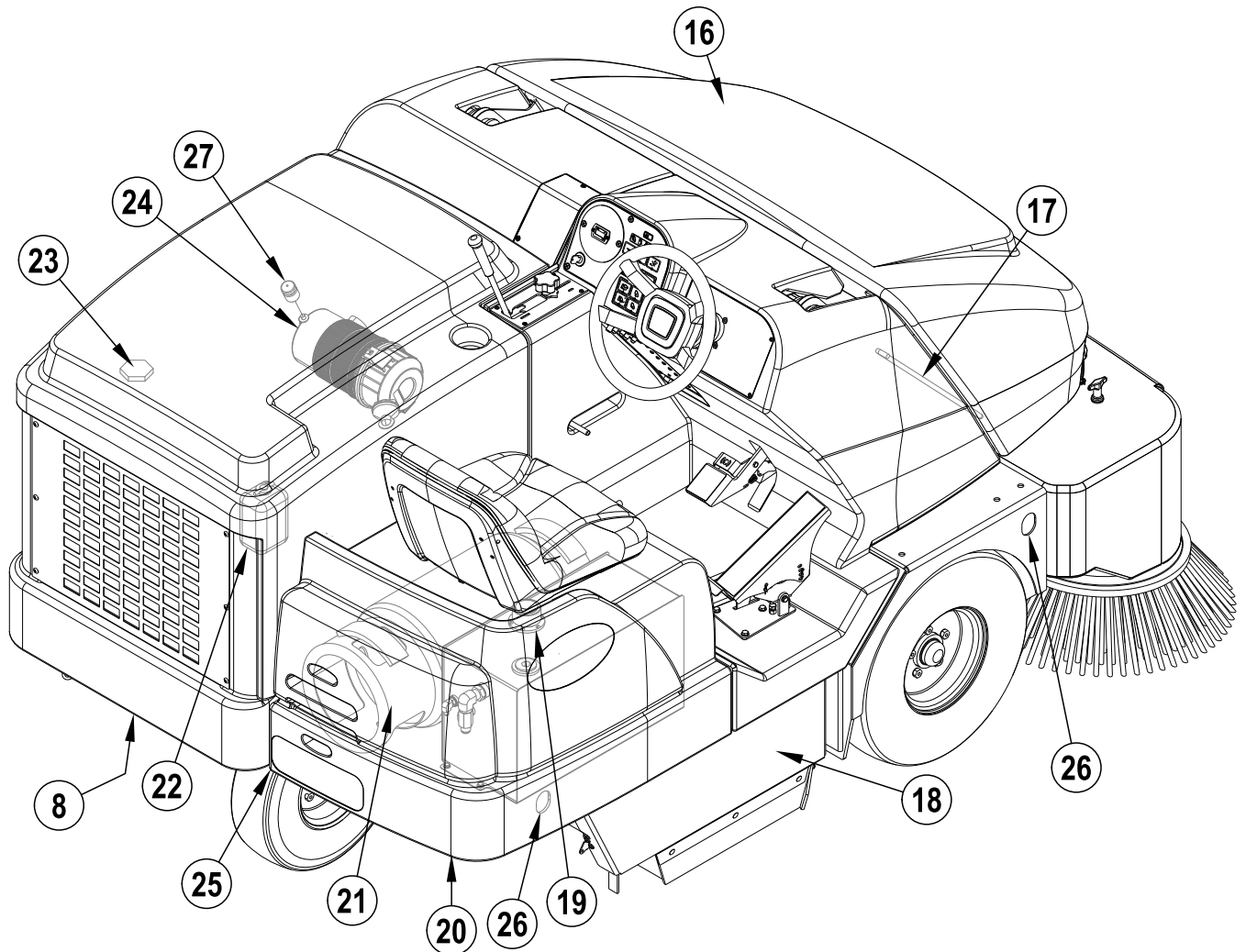

KNOW YOUR MACHINE

OPERATOR'S COMPARTMENT

- A Operator's Seat
- B Main Broom Lever
- C Main Broom Adjust Knob
- D Control Panel (See Associated Pages)
- E Steering Wheel
- F Brake Pedal / Parking Brake
- G FWD / REV Drive Pedal
- H Circuit Breaker Panel
- I Hopper Safety Support Handle
- J Operator Seat Adjustment Lever
- K Choke Cable* (3 Cylinder)

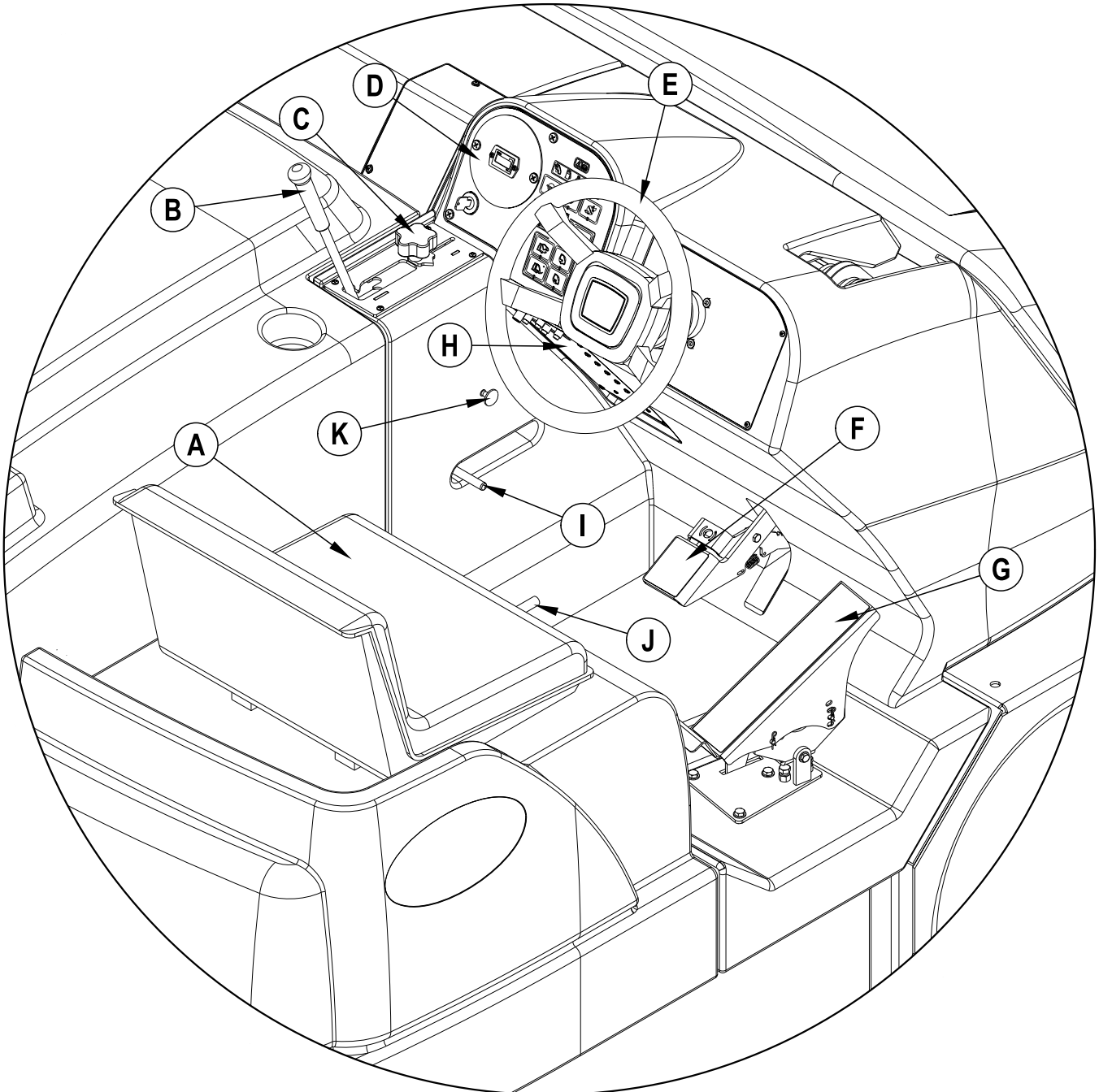

*To start: 1. Pull out choke knob. 2. Crank engine and push in at the same time.

KNOW YOUR MACHINE

CONTROL PANEL

- AA Fuel Gauge (Gasoline and Diesel Only)
- BB Horn Switch
- CC PROPANE Low Indicator Light
- DD Headlight Switch
- EE Check Engine Light MIL (GM 1.6L Only)
- FF Glow Plug Indicator Light (Diesel Only)
- GG Engine Speed Switch
- HH Side Broom ON-Down / OFF-Up Switch
- II Dust Control Indicator
- JJ Dust Control Switch
- KK Plugged Filter Indicator (optional)

- LL Shaker Switch
- MM Hopper UP Indicator
- NN Open Dump Door Switch
- OO Hopper Over-temp Indicator (optional)
- PP Close Dump Door Switch
- QQ Lower Hopper Switch
- RR Raise Hopper Switch
- SS Hour Meter
- TT Ignition Switch
- UU Main Controller Fault Code Light

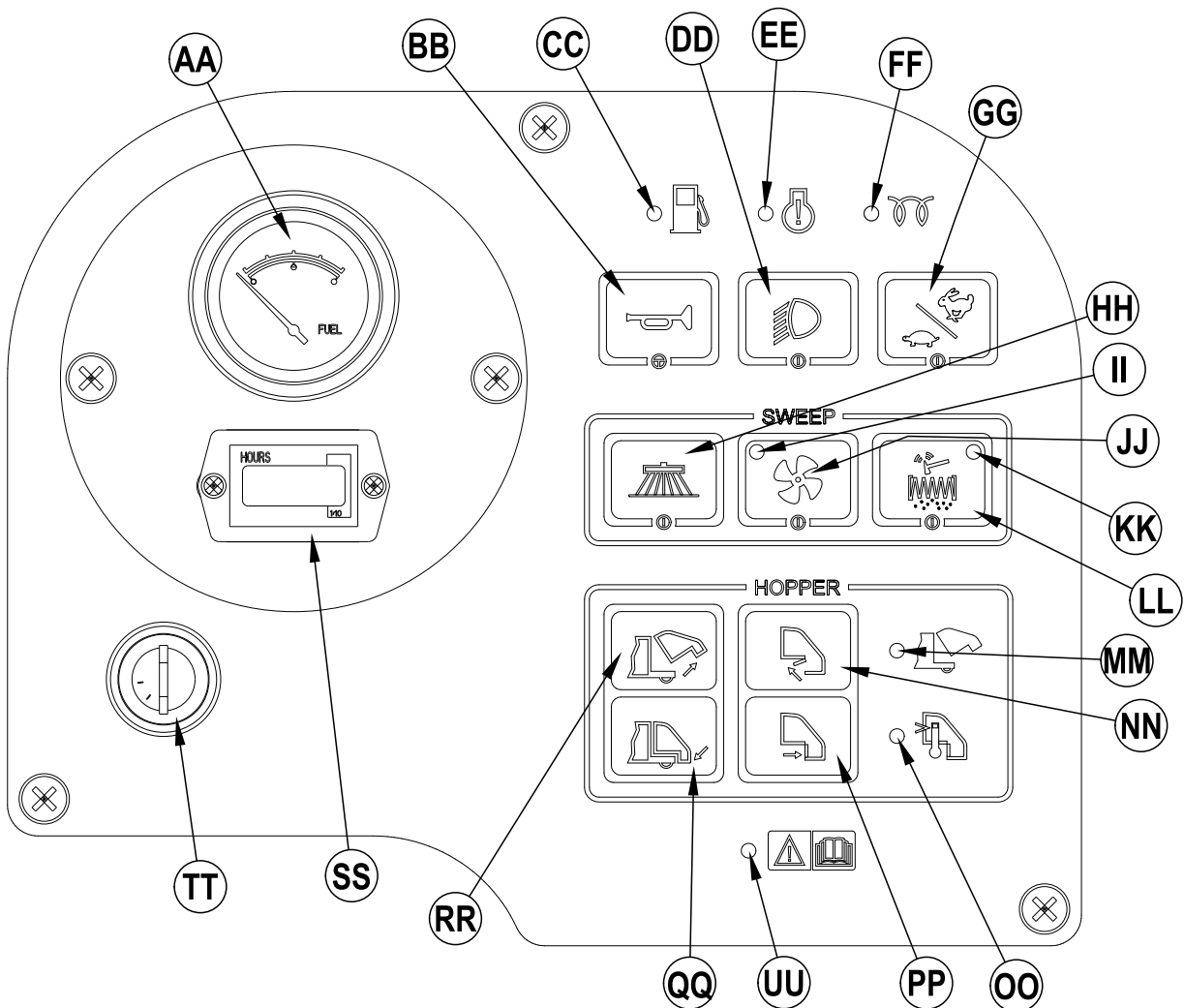

EXTERRA CONTROL PANEL DIAGNOSTICS

Function of the main controller's service indicator fault blink code display light

The A2 main controller will output a flashing fault code to the operator display panel when or if there is a problem (current overloads) associated with specific electrical low current circuit controller output functions. Examples of circuits; hydraulic solenoid coils used to turn on & off hydraulic loads and numerous relays used for activating machine function such as the headlights, horn, shaker motor, back-up alarm etc.

See Figure 1. When an A2 controller fault occurs the service indicator light (LED) (**UU**) will blink (flash) a special fault (error) code sequence until the fault is corrected. See "Table A" for a description of the fault indications.

Service Note: Instructions on how to read the fault code service indicator light. The service indicator LED blink code should operate as follows:

- First part of code (250mS period per flash – 125mS ON, 125mS OFF the 700mS LED OFF period).
- Second part of the code (250mS period per flash – 125mS ON, 125mS OFF the 700mS LED OFF period).
- 2 second LED off period
- Repeat sequence

If multiple faults are present, the codes should appear in order until all are displayed and then the entire sequence will repeat.

Example: Code1, 2

0 00 0 00 one light blink, a short pause two blinks, long pause and the code will be repeated.

LED on for 125mS
LED off for 700mS
LED on for 125mS
LED off for 125mS
LED on for 125mS
LED off for 2000mS
Repeat

FIGURE 1

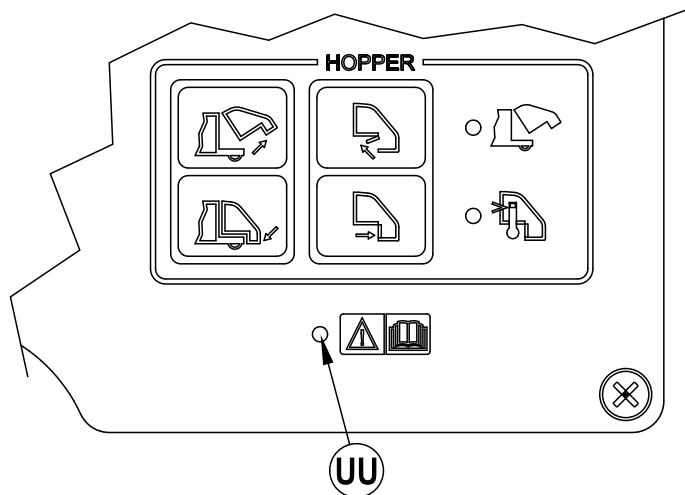

TABLE A

Fault Number	Service LED Blink Code	Fault Description	Output Pin #	Troubleshooting Action
1	1,1	Solenoid S1 hopper close/open overload Coil spec is 8 Ohms	J1-1	1. Check S1 coil wiring for a short circuit Vio + & Blu/Wht -. 2. Check coil resistance if below 6 Ohms replace.3. Substitute a new A2 control box.
2	1,2	Solenoid S2 main broom overload Coil spec is 8 Ohms	J1-2	1. Check S2 coil wiring for a short circuit Vio + & Grn/Gra -. 2. Check coil resistance if below 6 Ohms replace.3. Substitute a new A2 control box.
3	1,3	Solenoid S3 side broom overload Coil spec is 8 Ohms	J1-3	1. Check S3 coil wiring for a short circuit Vio + & Brn/Blk -. 2. Check coil resistance if below 6 Ohms replace.3. Substitute a new A2 control box.
4	1,4	Solenoid S4 dust control overload Coil spec is 8 Ohms	J1-4	1. Check S4 coil wiring for a short circuit Vio + & Brn/Yel -. 2. Check coil resistance if below 6 Ohms replace.3. Substitute a new A2 control box.
5	2,1	Solenoid S5 hopper up/down overload Coil spec is 8 Ohms	J1-5	1. Check S5 coil wiring for a short circuit Vio + & Red/Gra -. 2. Check coil resistance if below 6 Ohms replace.3. Substitute a new A2 control box.
6	2,2	Solenoid S6 hopper up/bypass overload Coil spec is 8 Ohms	J1-6	1. Check S6 coil wiring for a short circuit Vio + & Blu/Gra -. 2. Check coil resistance if below 6 Ohms replace.3. Substitute a new A2 control box.
7	2,3	Solenoid S7 hopper door/open overload Coil spec is 8 Ohms	J1-7	1. Check S7 coil wiring for a short circuit Vio + & Blk/Wht -. 2. Check coil resistance if below 6 Ohms replace.3. Substitute a new A2 control box.
8	2,4	Solenoid S8 dust control bypass overload Coil spec is 6 Ohms	J1-8	1. Check S8 coil wiring for a short circuit Vio + & Brn -. 2. Check coil resistance if below 4 Ohms replace.3. Substitute a new A2 control box.
9	3,1	Solenoid S9 hopper lower overload Coil spec is 8 Ohms	J1-9	1. Check S9 coil wiring for a short circuit Vio + & Yel/Grn -. 2. Check coil resistance if below 6 Ohms replace.3. Substitute a new A2 control box.
10	3,2	Shaker relay K3 overload Coil spec is 85 Ohms	J1-14	1. Check K3 coil wiring for a short circuit Vio + & Yel/Red -. 2. Check coil resistance if below 70 Ohms replace.3. Substitute a new A2 control box.
11	3,3	Back-up alarm overload	J1-15	1. Check the alarm wiring for a short circuit Vio + & Grn/Brn -. 2. Disconnect alarm wiring if overload goes away replace the alarm if not substitute a new A2 control box.
12	3,4	Light relay K2 overload Coil spec is 85 Ohms	J1-16	1. Check K2 coil wiring for a short circuit Vio + & Yel/Wht -. 2. Check coil resistance if below 70 Ohms replace.3. Substitute a new A2 control box.
13	4,1	Neutral start relay K4 overload Coil spec is 85 Ohms	J1-18	1. Check K4 coil wiring for a short circuit Vio + & Gry/Wht -. 2. Check coil resistance if below 70 Ohms replace.3. Substitute a new A2 control box.
14	4,2	Horn relay K1 overload Coil spec is 85 Ohms	J1-19	1. Check K1 coil wiring for a short circuit Vio + & Vio/Brn -. 2. Check coil resistance if below 70 Ohms replace.3. Substitute a new A2 control box.
15	4,3	Engine speed output overload Note the Gra/Blu wire is 0 V's when engine is @ idle.	J1-17	1. Throttle input to engine A3 ECM (GM), Woodward governor (diesel) or A1 throttle control module (Kubota) is +12V for high speed. Check Gra/Blu wire for a short to ground. 2. Substitute a new A2 control box.
16	4,4	Spare overload Not used at this time	J1-12	NA

GENERAL MACHINE SYMPTOM TROUBLESHOOTING GUIDE TABLE OF CONTENTS

Engine System.....	23-33
Kubota 3 cylinder G/LP or 4 cyl diesel engine will not crank.....	23
Kubota 3 cylinder engine G/LP will crank but not start.....	24
Kubota 3 cylinder engine will not run at high speed.....	25
1.6L GM 4 cylinder engine will not crank.....	26-27
1.6L GM 4 cylinder engine will crank but not start.....	28-29
1.6L GM engine will not run at high speed.....	30
Diesel engine will crank but not start.....	31-32
Diesel engine will not run at high speed.....	33
Wheel Drive System (Troubleshooting check list).....	34
Steering System (Troubleshooting guide).....	35
Sweep System.....	36-44
Main broom will not run.....	36-37
Side brooms will not run.....	38-39
Side brooms will not raise/lower.....	40
Dust control impeller will not run.....	41-42
Shaker motor will not run.....	43-44
Hopper System.....	45-51
Hopper will not raise.....	45-46
Hopper will not lower.....	47-48
Hopper dump door will not open (Part A).....	49, 51
Hopper dump door will not close (Part A).....	50-51
Hopper dump door will not open or close (Part B).....	51
Solution System.....	52-53
Dust control misting pump will not operate (Optional).....	52-53

Note: To aid in machine system troubleshooting; see the electrical and hydraulic manual sections for additional drawings of part component locations and diagrams to support wiring and hydraulic circuits.

ENGINE SYSTEM TROUBLESHOOTING GUIDE

Symptom

Kubota 3 cylinder G/LP or 4 cylinder diesel engine will not crank

Part A: Electrical Control and Load Circuit

Note 1: To test the key switch must be in Start position and the foot-pedal in neutral.

Note 2: Before T.S. check the CB1 60 Amp circuit breaker & 12V 's @ key switch Bat terminal.

Note 3: Before T.S. check Battery voltage @ starter main load red wire.

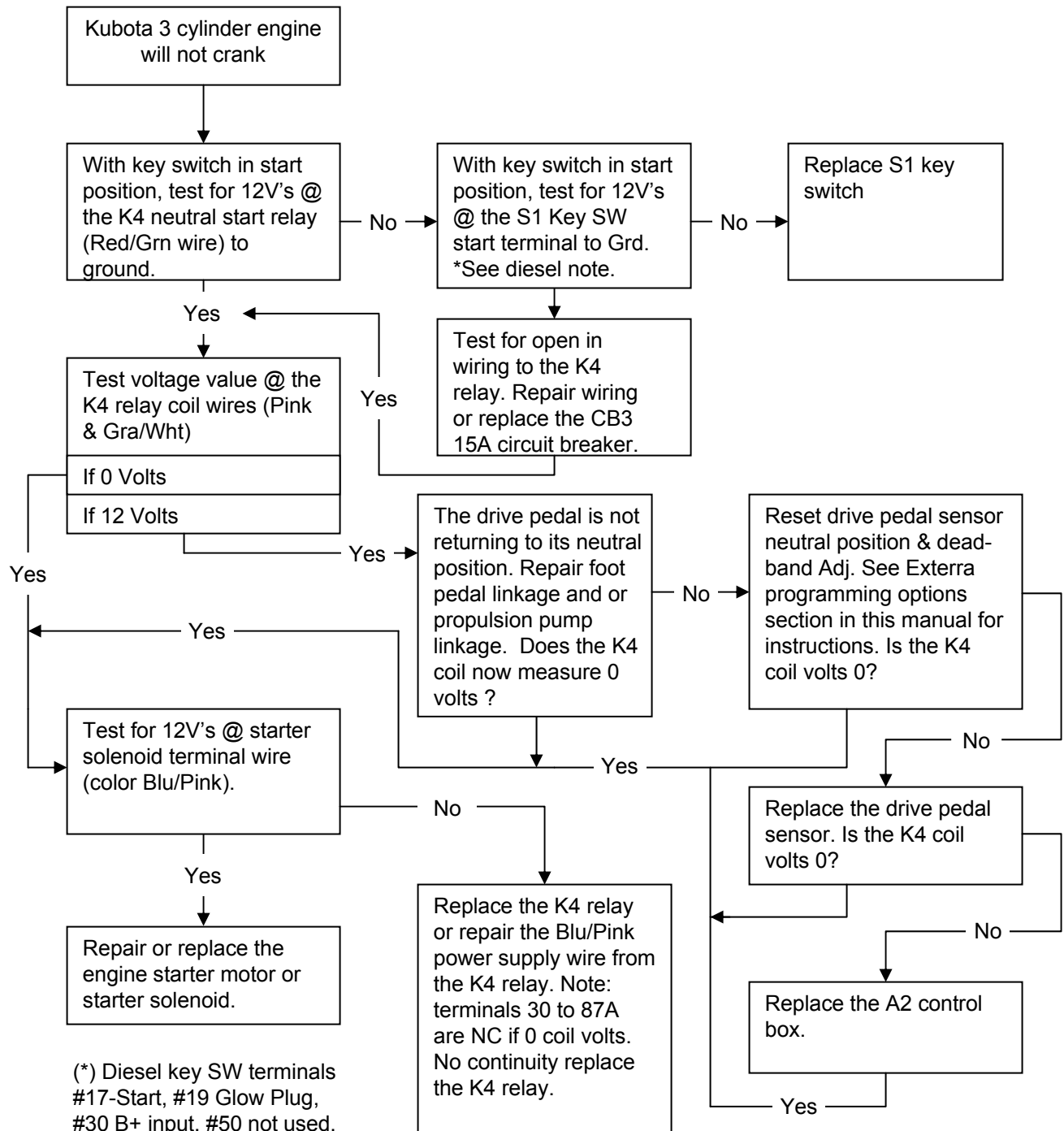

(*) Diesel key SW terminals #17-Start, #19 Glow Plug, #30 B+ input, #50 not used, AC-Accessory

ENGINE SYSTEM TROUBLESHOOTING GUIDE

Symptom

Kubota 3 cylinder engine G/LP will crank but not start

Part A: Electrical Control Circuit

Note 1: Check for 12V's at the CB5 ignition circuit breaker 10A. If no input voltage @ the Orn/Grn wire repair or replace wiring or key switch.

Note 2: Check the fuel supply (empty tank).

Note 3: Follow proper engine starting steps reference operator manual.

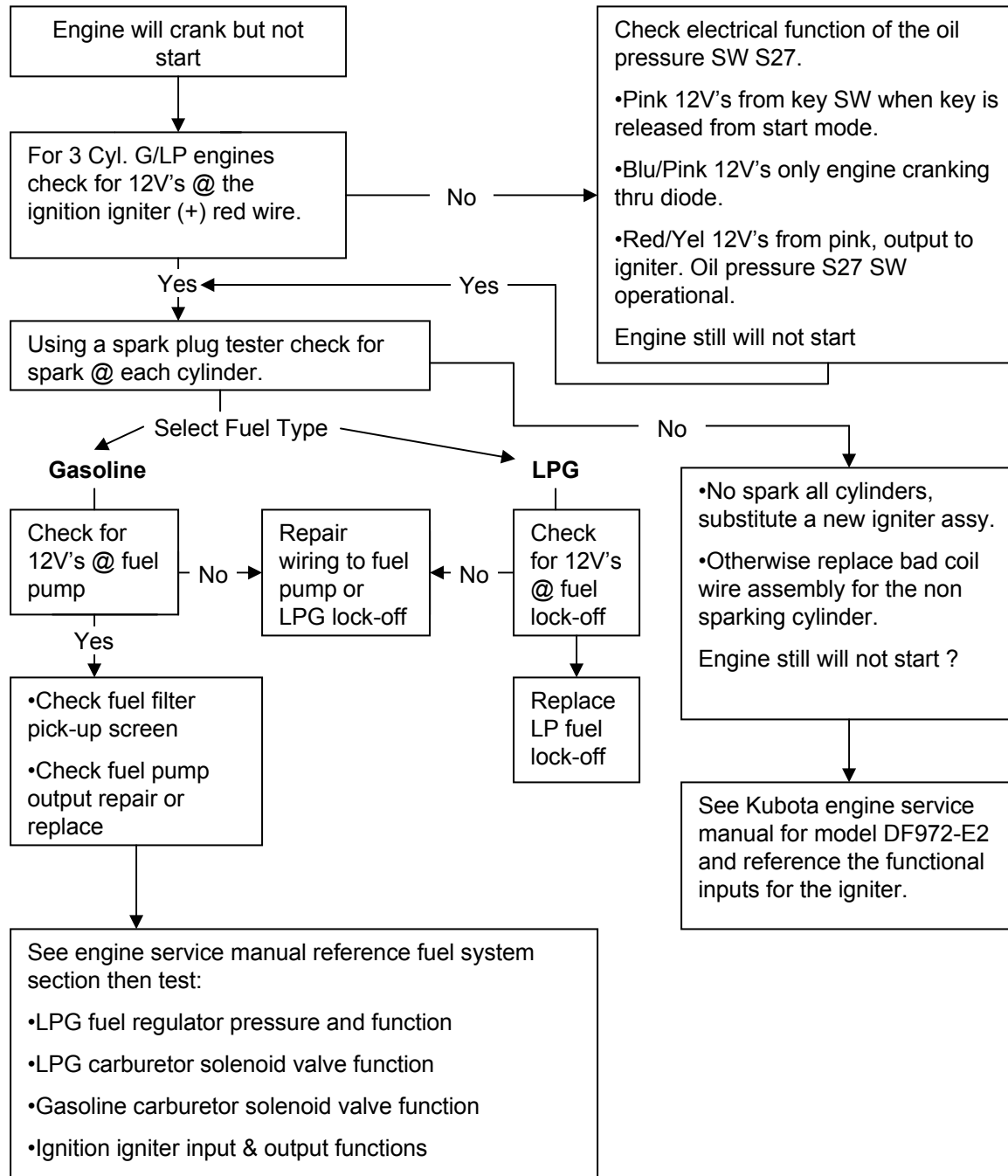

ENGINE SYSTEM TROUBLESHOOTING GUIDE

Symptom

3 Cylinder engine will not run at high speed

Note: With the engine running at idle press the engine speed switch to activate the high speed engine function. Before troubleshooting inspect and test the 30A F2 fuse. If fuse condition is questioned substitute a new fuse.

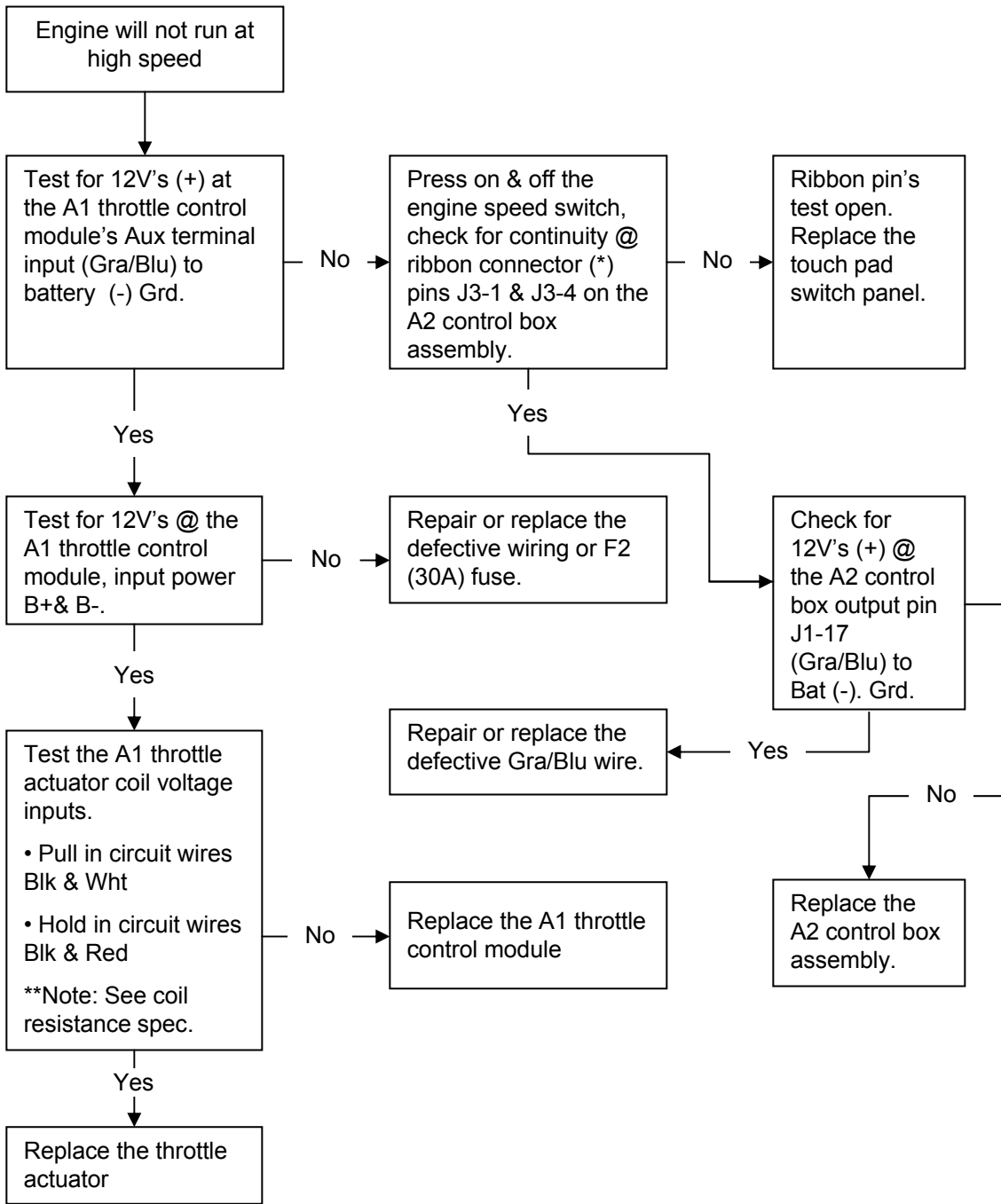

* Ribbon connector see Electrical System Figure 1 for detail pin call-outs.

**Note: "Pull In" coil resistance 0.3 Ohms and "Hold In" coil resistance 14 Ohms.

ENGINE SYSTEM TROUBLESHOOTING GUIDE

Symptom

GM 1.6L 4 cylinder engine will not crank

Part A: Electrical Control and Load Circuit

Note 1: To test the key switch must be in Start position and the foot-pedal in neutral.

Note 2: Before T.S. check the CB1 60 Amp circuit breaker & 12V 's @ key switch Bat terminal.

Note 3: Before T.S. check Battery voltage @ starter main load red wire.

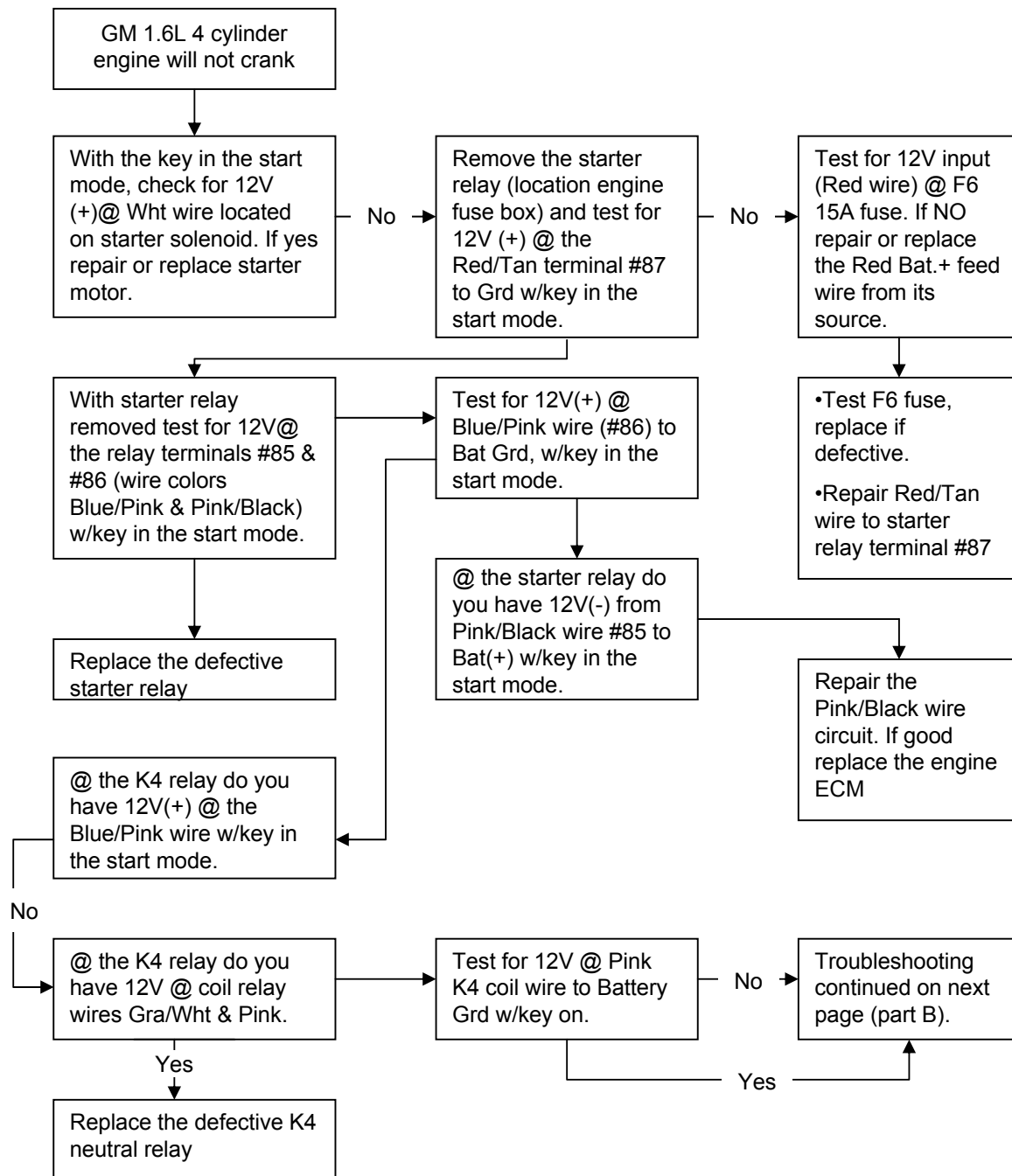

Note A: Any time the machines hydrostat mounted neutral position sensor is replaced or the hydrostat linkage adjusted its neutral position must be re-programmed. Also any time the A2 control box is replaced it must be re-programmed. See the programming options section in this manual for instructions.

ENGINE SYSTEM TROUBLESHOOTING GUIDE

Symptom

GM 1.6L 4 cylinder engine will not crank

Part B: Electrical Control and Load Circuit

Note 1: To test the key switch must be in start position and the foot-pedal in neutral. Also reference Note: A below.

Note 2: Before T.S. check the CB1 60 Amp circuit breaker & 12V's @ key switch Bat. Terminal.

Note 3: Before T.S. check battery voltage @ starter main load red wire input.

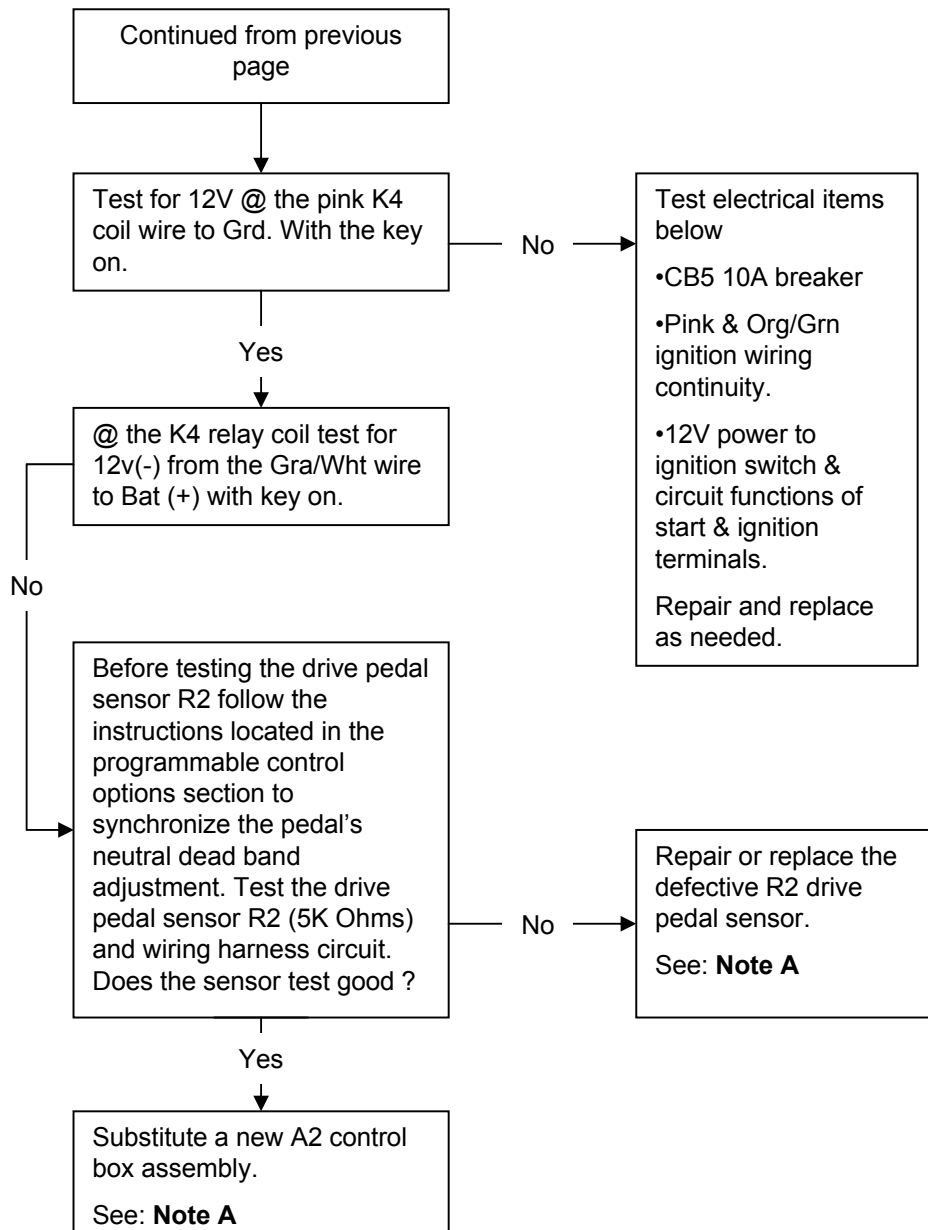

Note A: Any time the machines hydrostat mounted neutral position sensor is replaced or the hydrostat linkage adjusted its neutral position must be re-programmed. Also any time the A2 control box is replaced it must be re-programmed. See the programming options section in this manual for instructions.

ENGINE SYSTEM TROUBLESHOOTING GUIDE

Symptom

GM 1.6L 4 cylinder engine will crank but not start

Part A:

Note 1: Check for 12V's at the CB5 ignition circuit breaker 10A. If no input voltage @ the Orn/Grn wire repair or replace wiring or key switch. Note 2: Check the fuel supply (empty tank). Note 3: Check the condition of the spark plugs, replace if needed.

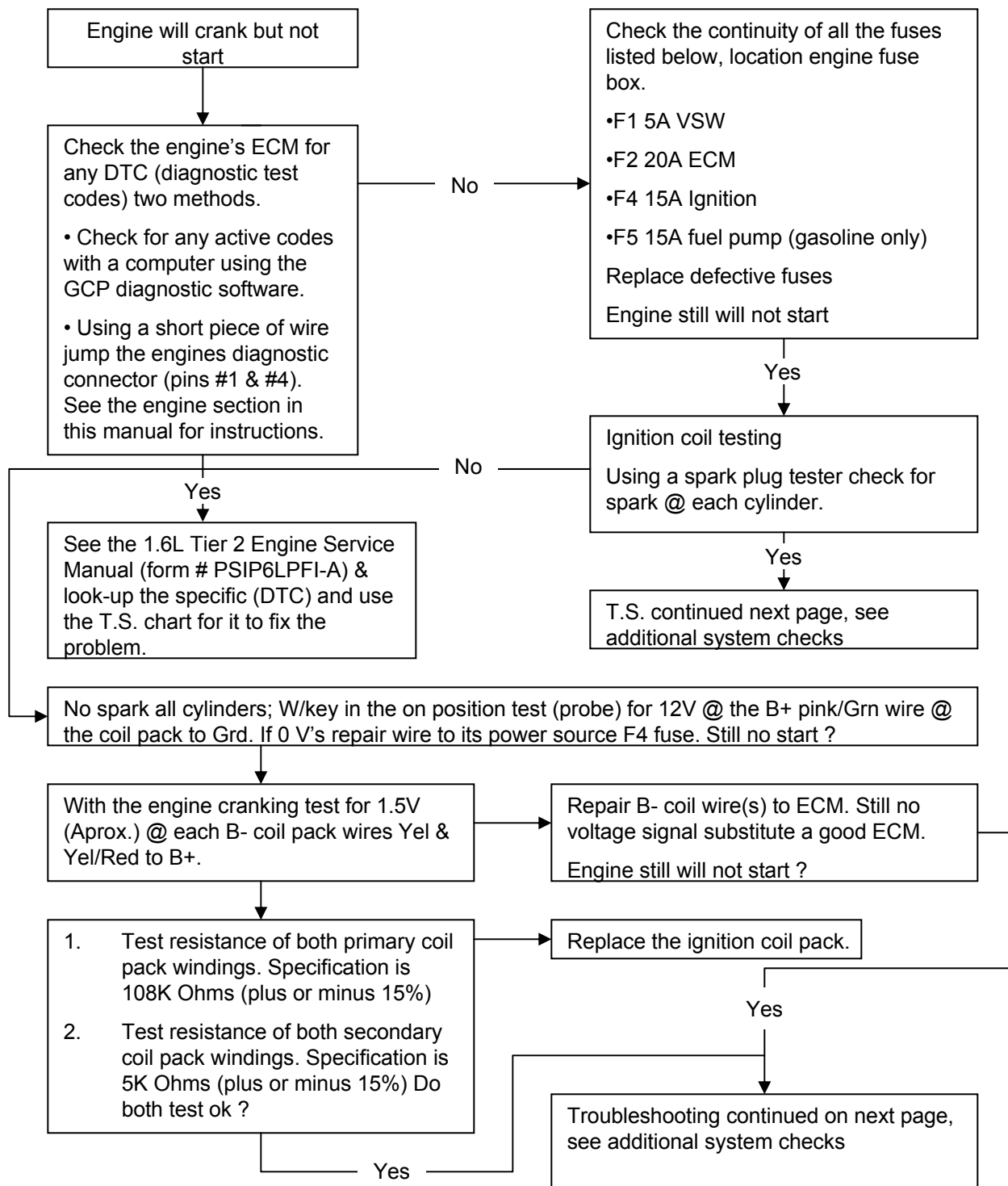

ENGINE SYSTEM TROUBLESHOOTING GUIDE

Symptom

GM 1.6L 4 cylinder engine will crank but not start

Part B:

Note 1: Check for 12V's at the CB5 ignition circuit breaker 10A. If no input voltage @ the Orn/Grn wire repair or replace wiring or key switch. Note 2: Check the fuel supply (empty tank). Note 3: Check the condition of the spark plugs, replace if needed.

Troubleshooting continued
from previous page



Follow the preliminary system checks listed below for engine cranks but does not start

Fuel System Checks LP

- Check for air intake system leakage between the mixer and throttle body.
- Verify proper operation of the low pressure lock-off solenoid valve.
- Check the fuel system pressure. Refer to the LPG fuel system diagnosis for instructions & Specification.
- Check for proper mixer air valve operation. Note the air valve must vibrate back & forth when cranking. No vibration look for an intake system leak. Example: The block-off injector plugs loose or missing.
- Reference the 1.6L tier 2 engine service manual and follow the LPG system diagnosis.

Fuel System Checks for Gasoline

- Check fuel pump electrical circuit, fuel pump pressure and fuel rail pressure.
- Check electrical connections at the fuel injection solenoids.
- Check for air intake system leakage between the throttle body & intake manifold sealing surfaces. Also any vacuum hoses for splits, kinks and proper connections
- Reference the 1.6L tier 2 engine service manual and follow the gasoline system diagnosis.

Sensor Checks

- Check the TMAP sensor.
- Check the magnetic pickup sensor (RPM).

Miscellaneous Electrical and Visual Checks

- Check engine harness wiring for proper connections, pinches or cuts.
- Check the ECM & engine ground for: tight clean connection, size and proper location.
- Check spark plug wires for: cracking/hardness, tight connections, proper routing & firing order.
- Check thoroughly for any type of a leak or restriction. Examples: Intake filter blocked, exhaust restriction @ muffler (Cat), a leaking exhaust manifold etc.

ENGINE SYSTEM TROUBLESHOOTING GUIDE

Symptom

4 cylinder 1.6 GM engine will not run at high speed

Note: With the engine running at idle press the engine speed switch to activate the high speed engine function..

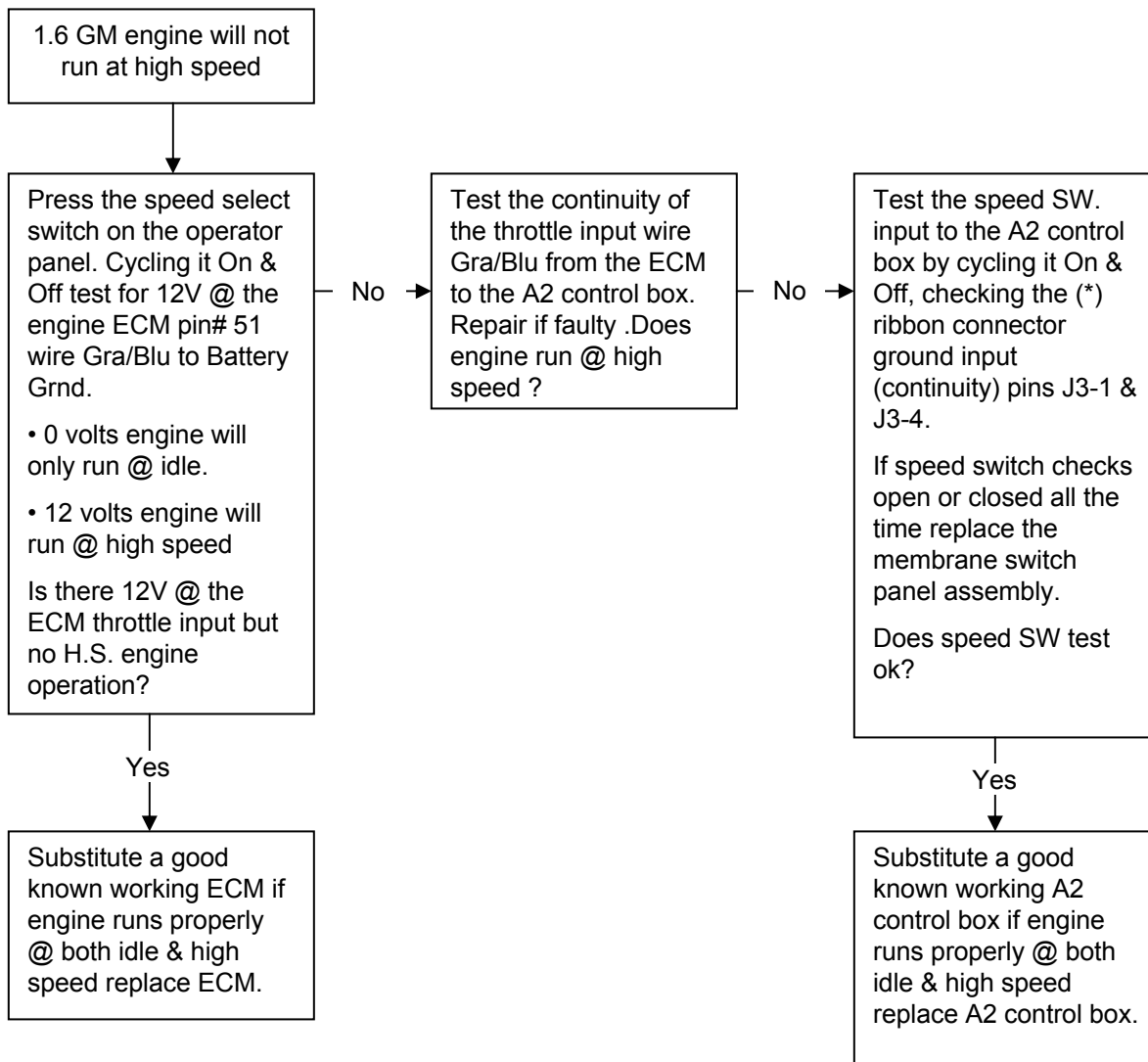

* Ribbon connector see Electrical System Figure 1 for detail pin call-outs.

ENGINE SYSTEM TROUBLESHOOTING GUIDE

Symptom

Part1: Diesel engine will crank but not start

Note1: Always use (activate) the glow plugs circuit to start an engine that is not up to its operating temperature.

Note 2: Before troubleshooting inspect the 10A CB5 circuit breaker.

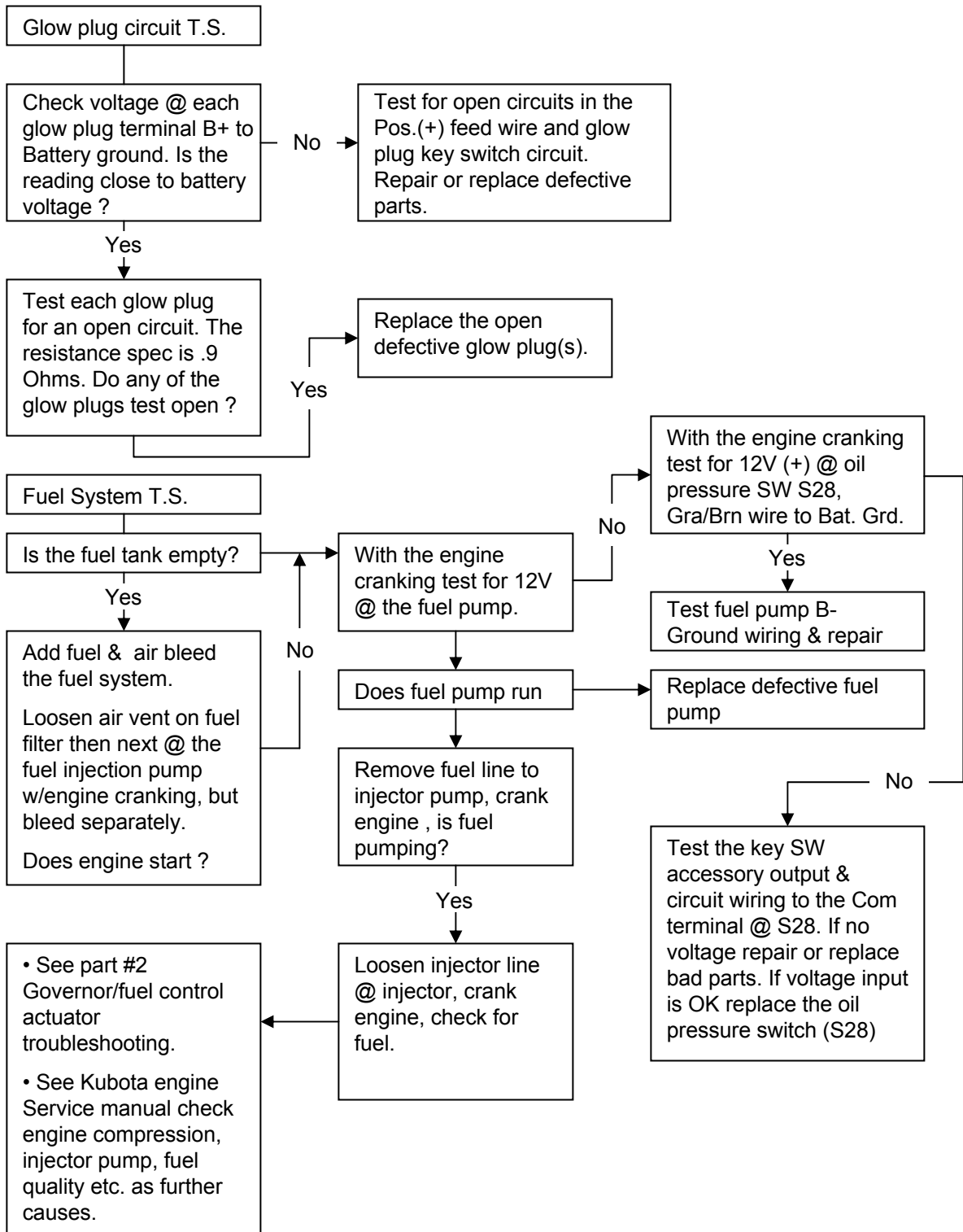

ENGINE SYSTEM TROUBLESHOOTING GUIDE

Symptom

Part 2: Diesel engine will crank but not start

Note: Always use (activate) the glow plugs circuit to start an engine that is not up to its operating temperature. Note 1: Before troubleshooting inspect the 10A CB5 circuit breaker, replace if defective.

Note 2: The engine uses a low oil pressure shut down feature. Check to see that the engine oil fill level is correct. As no oil will prevent the engine from starting, for its own protection (5PSI) is min. pressure to open switch S28 for engine to start.

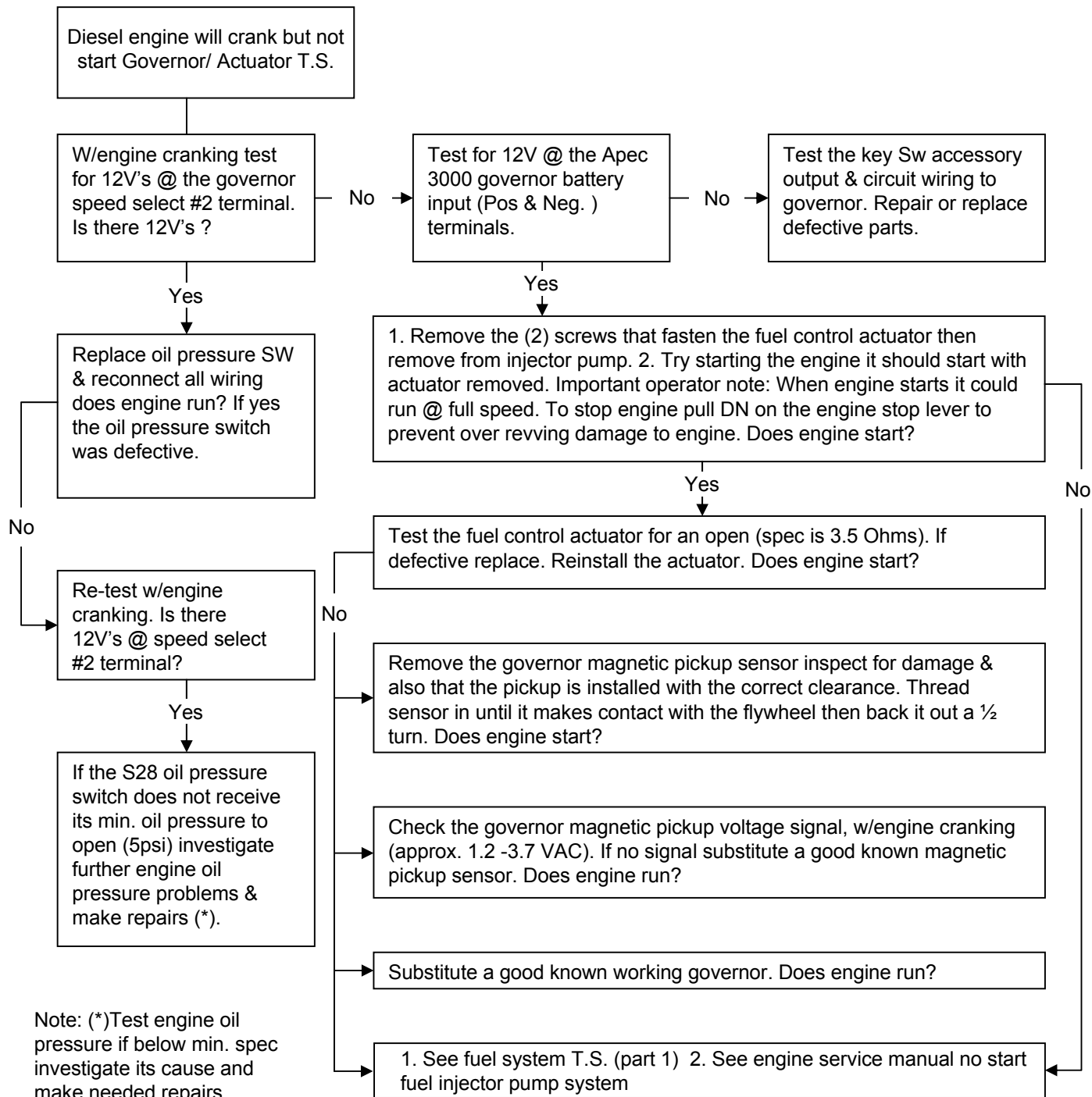

ENGINE SYSTEM TROUBLESHOOTING GUIDE

Symptom

Diesel engine will not run at high speed

Note: With the engine running at idle press the engine speed switch to activate the high speed engine function.

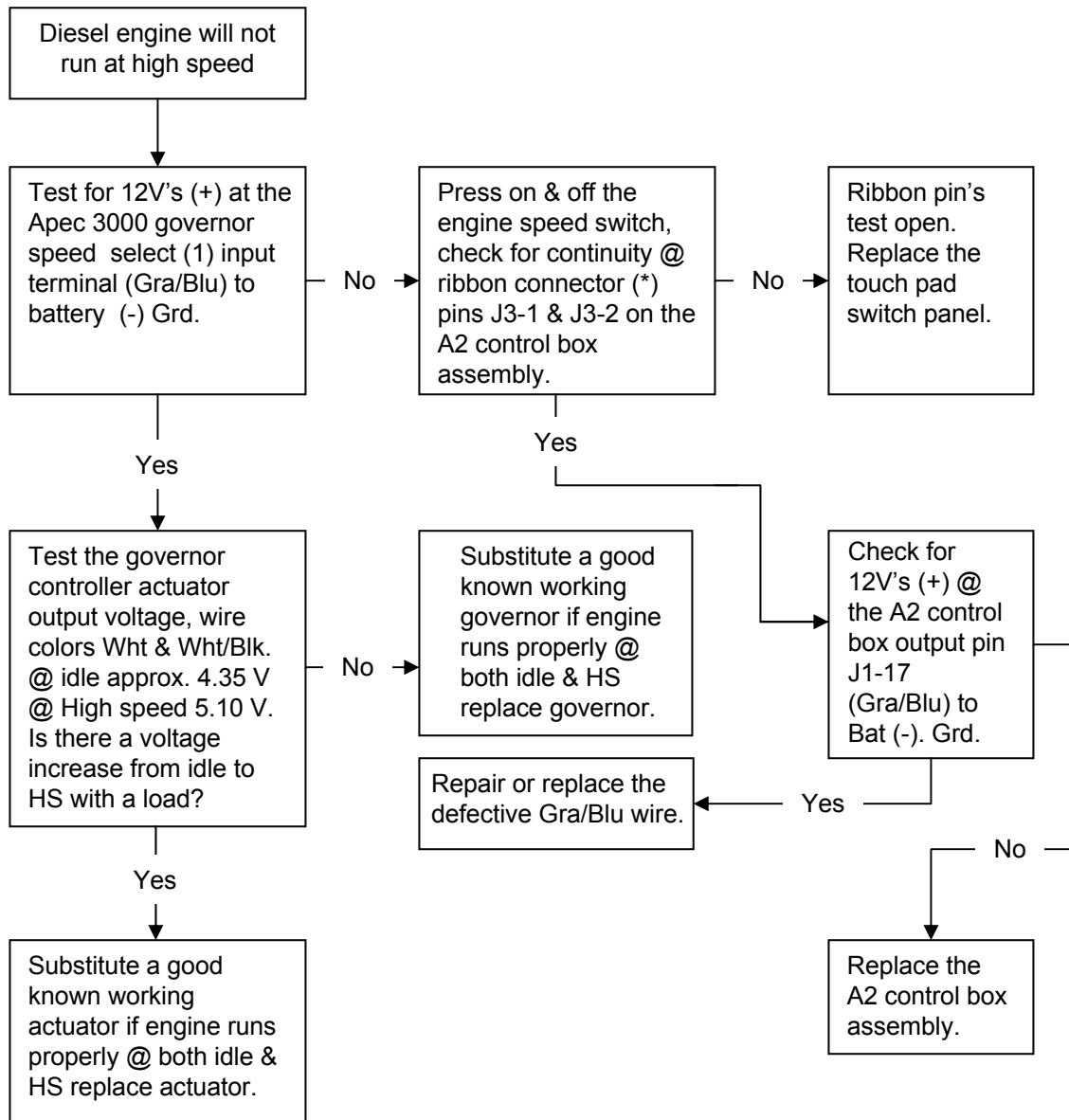

* Ribbon connector see Electrical System Figure 1 for detail pin call-outs.

WHEEL DRIVE SYSTEM

Hydraulic Wheel Drive System

Troubleshooting Check List

Symptom	Possible Cause
Wheel drive functions sluggish or slow	<ul style="list-style-type: none">• Engine not operating in high-speed setting or engine speed is too slow (2400 RPM).• Air in hydraulic fluid (loose fittings).• Propulsion pump inlet restriction (cavitation of hydraulic fluid).• Worn drive wheel motor (*test working pressure & wheel drive speed).
Wheel drive in one direction only	<ul style="list-style-type: none">• Inspect propulsion pump relief valves for:<ul style="list-style-type: none">A. Debris that allows valve seat to be held open,B. Damaged or weak valve spring,C. Valve unloading pressure setting too low for application.
No wheel drive in either direction	<ul style="list-style-type: none">• Check that pump bypass valve (tow valve) is in correct position.• Check connection of foot pedal linkage (cable assembly) to propulsion pump arm.• Worn propulsion pump (*test output oil volume with a flow meter).• Defective propulsion pump charge circuit. Test its relief valve pressure setting (65-100 psi).• Worn or damaged wheel drive motor
No hydraulic system functions drive or accessory	<ul style="list-style-type: none">• Check for a damaged coupling connection from the engine to the pump shaft input.

*Note: See in the hydraulic specification manual section, tables that list all the individual system component values (pressures, flows, RPMs etc).

STEERING SYSTEM

STEERING SYSTEM TROUBLESHOOTING OVERVIEW

See Figure 1. A hydraulic steering unit, with the steering wheel mounted to it, controls the steer cylinder. The steering unit runs off the auxiliary pump assembly. The oil flows through a priority divider built into the manifold block assembly that divides the pump output and reduces the oil flow to 2.0 GPM for the steering system. There is a check valve built into the steering unit that allows for manual steering if there is no hydraulic oil flow to the unit. The relief valve for the steering system is located in the steering unit and is set to open at 1100 PSI.

FIGURE 1

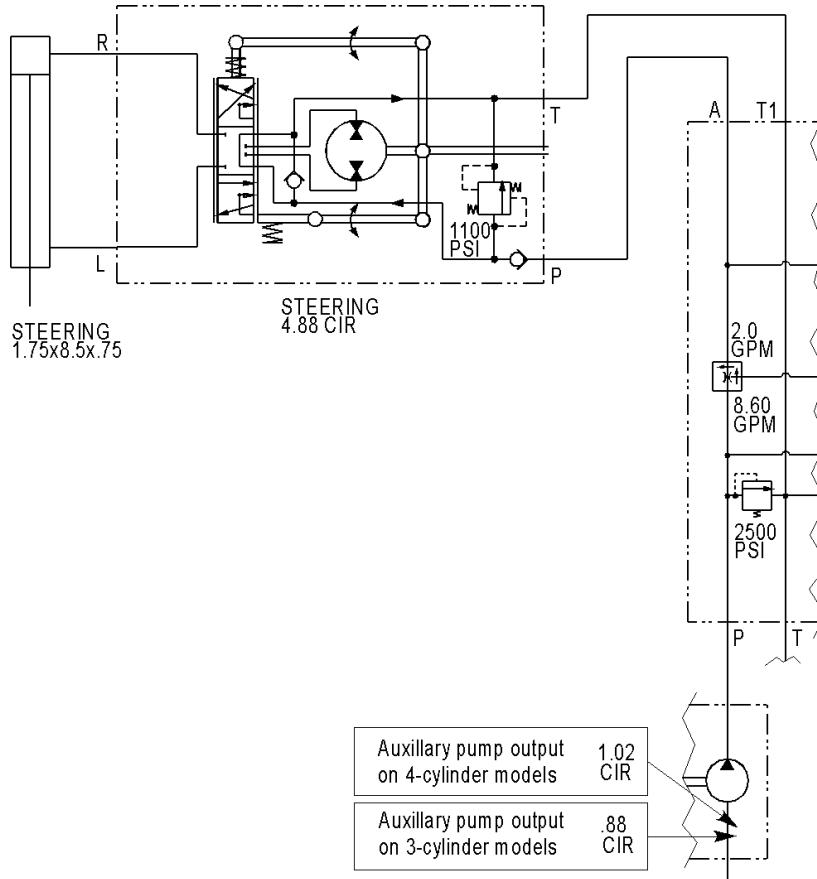

Steering System Hydraulic Diagram

TROUBLESHOOTING GUIDE

Problem	Possible cause
Slow steering, hard steering or loss of Power assist.	Priority flow divider not providing 2.0 GPM.
	1100 PSI relief valve open or malfunctioning.
Steering wandering.	Loose or leaking cylinder piston packing.
	Steering control unit worn.
Steering wheel turns freely without moving wheel.	Problem with steering column Shaft or spline.
Steering binding.	Steer cylinder loose.

SWEEPING SYSTEM TROUBLESHOOTING GUIDE

Symptom

Main broom motor will not run

Part A: Electrical Control Circuit

Note 1: Do all testing with the engine running at high speed, the main broom lowered (sweep position) and the drive pedal activated (machine moving).

Note 2: The main broom magnetic switch S2 must be open and also the hopper interlock switch S4 closed, for the main broom system (motors) to run.

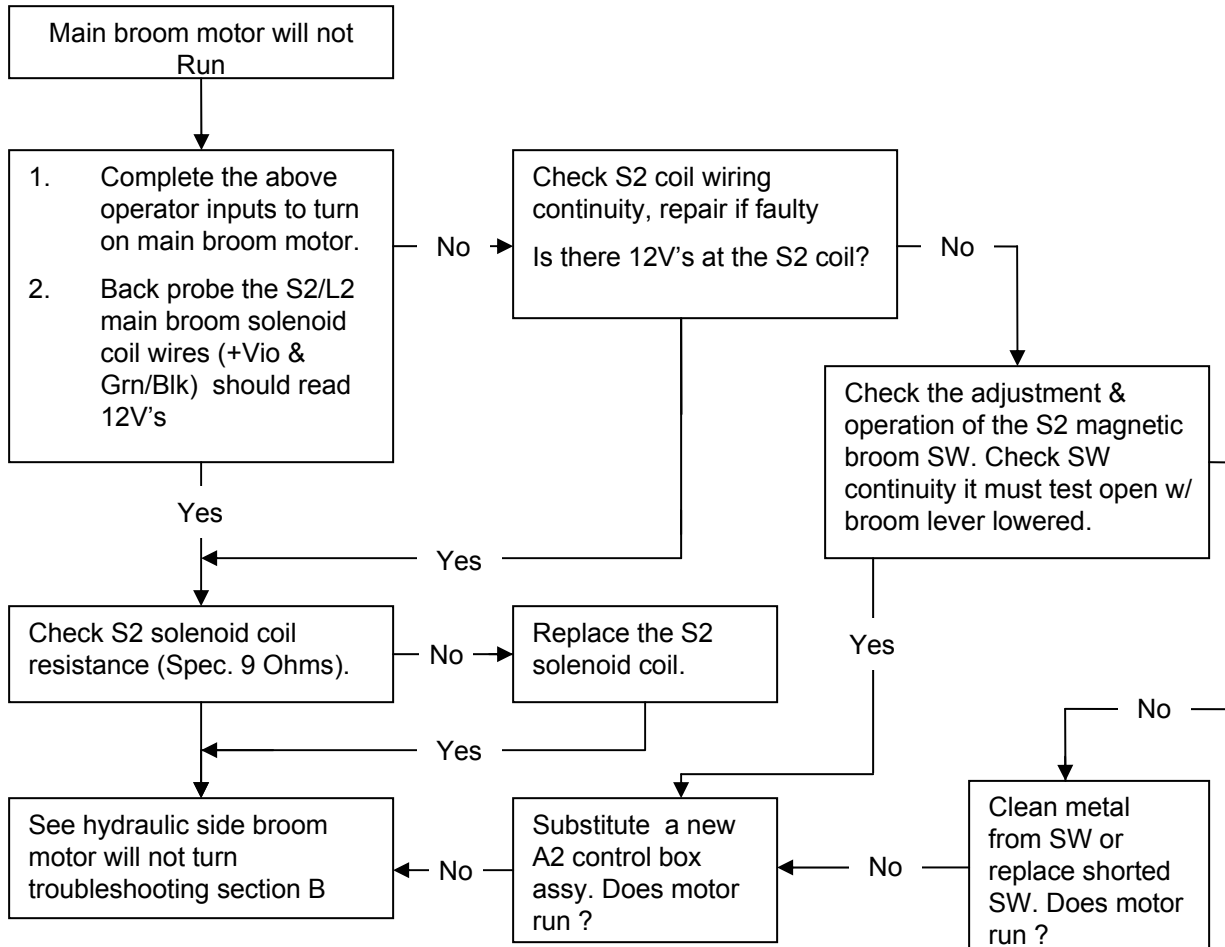

SWEEPING SYSTEM TROUBLESHOOTING GUIDE

Symptom

Main broom motor will not run

Part B: Hydraulic Load Circuit

Note 1: Do all testing with the engine running at high speed, the main broom lowered (sweep position) and the drive pedal activated (machine moving).

Note 2: The main broom magnetic switch S2 must be open and also the hopper interlock switch S4 closed, for the main broom system (motors) to run.

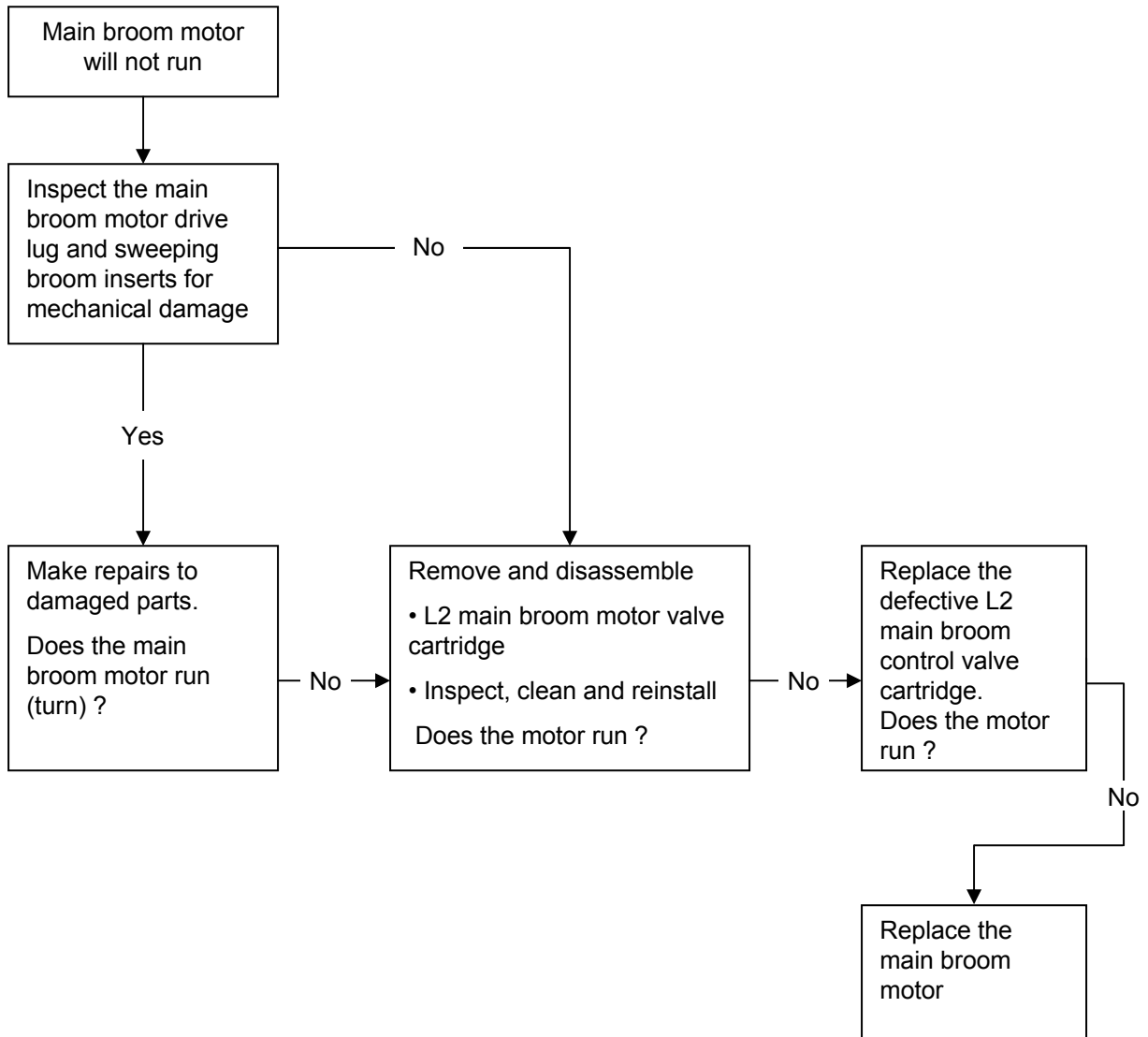

SWEEPING SYSTEM TROUBLESHOOTING GUIDE

Symptom

Side broom motor(s) will not run

Part A: Electrical Control Circuit

Note 1: Do all testing with the engine running at high speed, the main broom lowered (sweep position) and the drive pedal activated (machine moving). When the above steps are completed the side broom(s) will lower automatically and turn ON (rotate).

Note 2: By pressing the control panel side broom ON/OFF switch during sweeping the side broom will be raised and turned OFF.

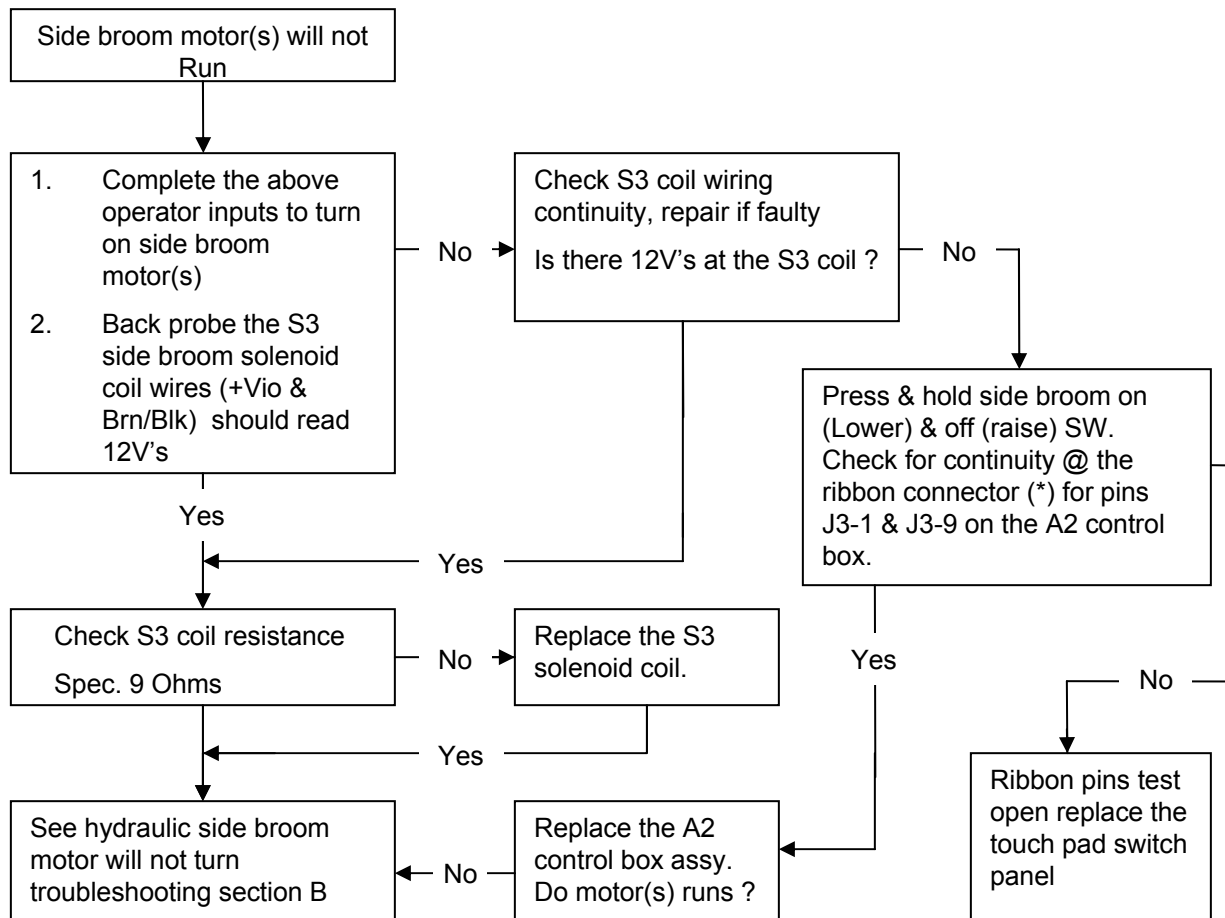

* Ribbon connector see Electrical System Figure 1 for detail pin call-outs.

SWEEPING SYSTEM TROUBLESHOOTING GUIDE

Symptom

Side broom motor(s) will not run

Part B: Hydraulic Load Circuit

Note 1: Do all testing with the engine running at high speed, the main broom lowered (sweep position) and the drive pedal activated (machine moving). When the above steps are completed the side broom(s) will lower automatically and turn ON (rotate).

Note 2: By pressing the control panel side broom ON/OFF switch during sweeping the side broom will be raised and turned OFF.

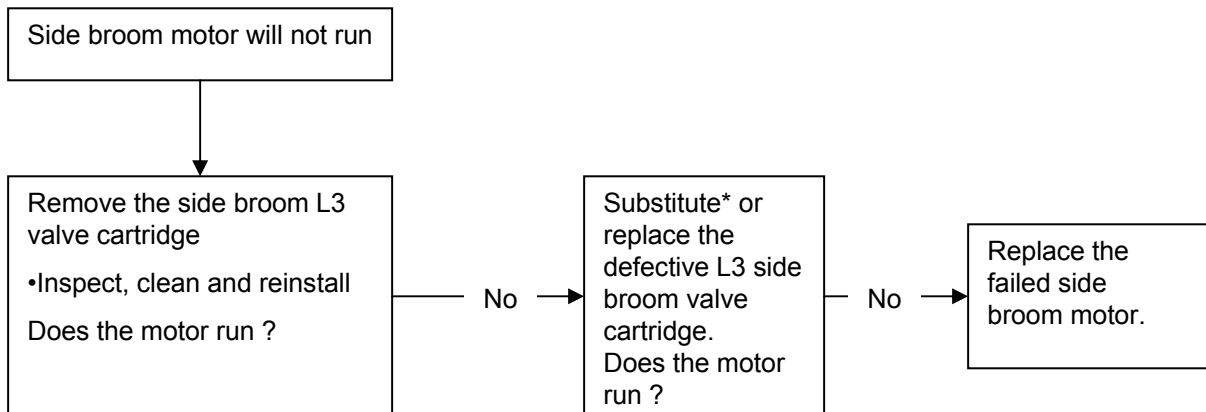

*Substitute valve cartridge numbers 3 & 7 they are the same and can be swapped to help troubleshoot the system.

SWEEPING SYSTEM TROUBLESHOOTING GUIDE

Symptom

Side broom(s) will not raise or lower.

Mechanical and Hydraulic functions

Note 1: Do all testing with the engine running at high speed, the main broom lowered (sweep position) and the drive pedal activated (machine moving).

Note 2: The main broom magnetic switch S2 must be open and also the hopper interlock switch S4 closed. for the main broom system (motors) to run. Operating the main broom will automatically lower the side brooms. Press the side broom off button or raise the main broom lever to raise the side brooms.

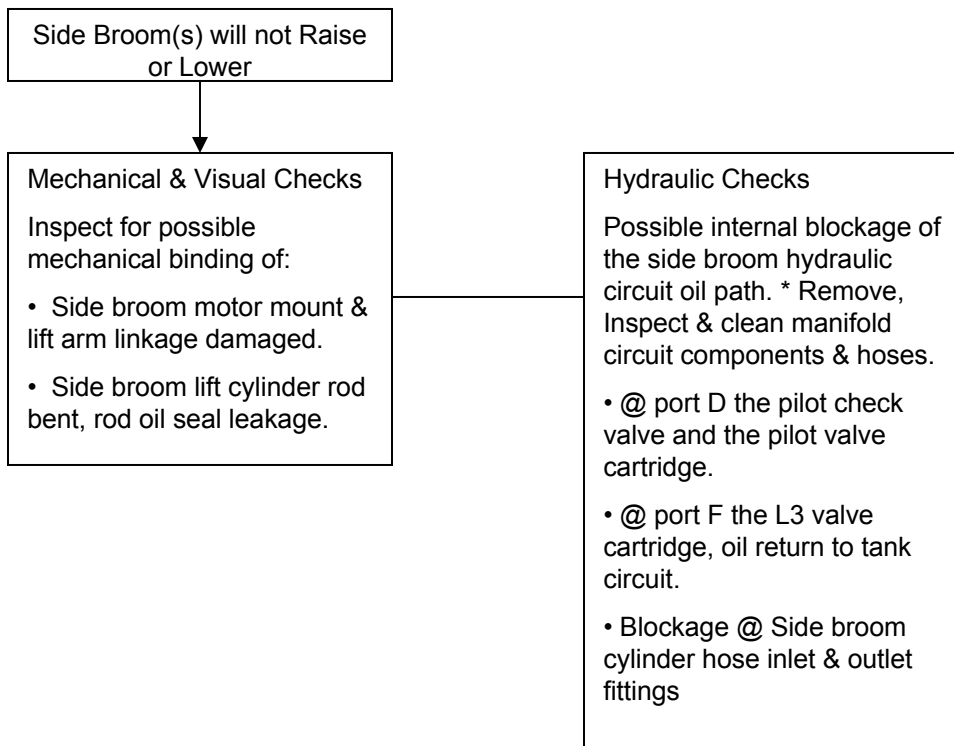

* Note: See hydraulic system manual section for system specifications and troubleshooting information.

SWEEPING SYSTEM TROUBLESHOOTING GUIDE

Symptom

Dust control (impellor) motor will not run in the wand state

Part A: Electrical Control Circuit

Note: Do all testing with the engine running at high speed and the dust control switch pressed (activated).

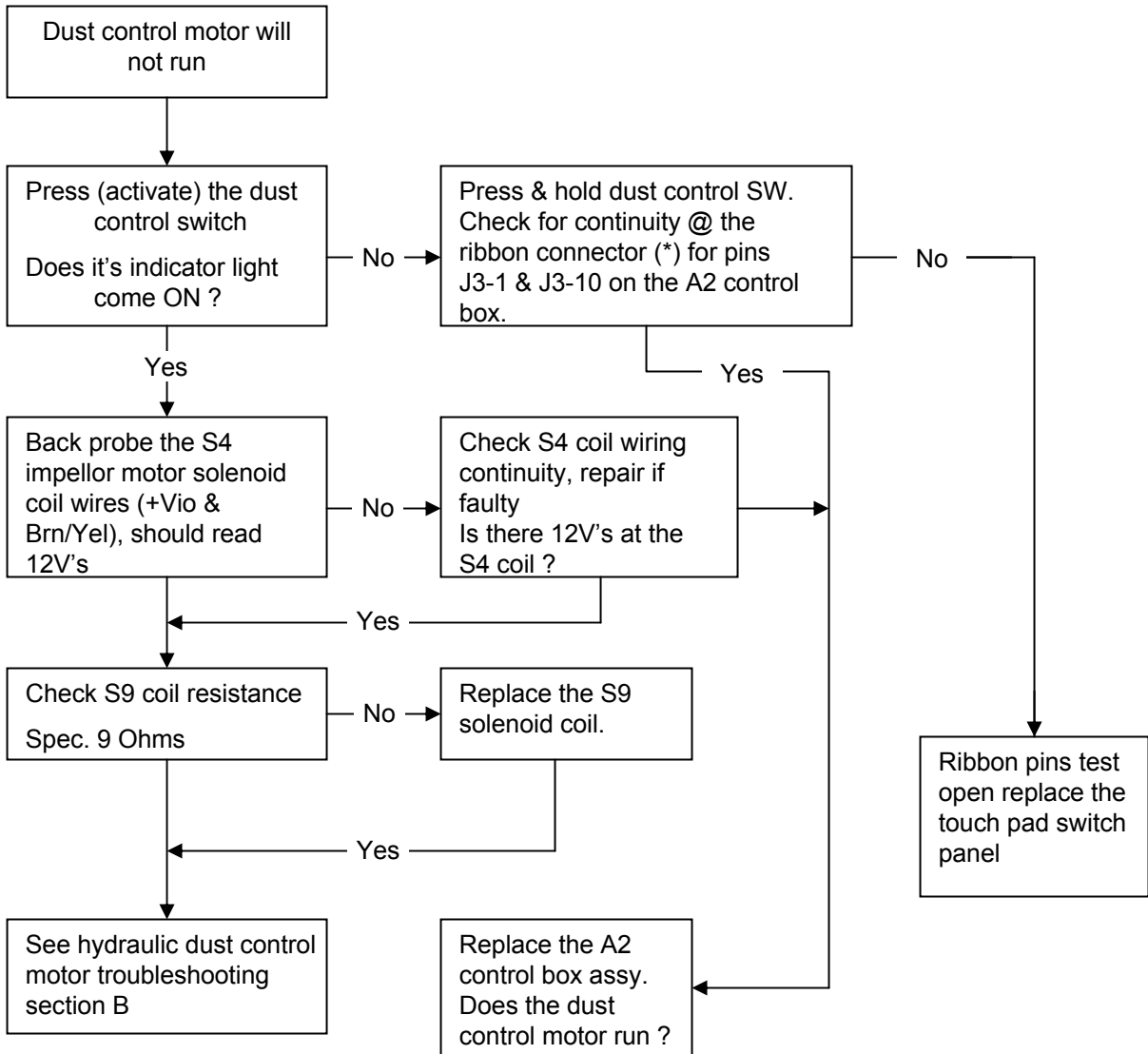

* Ribbon connector see Electrical System Figure 1 for detail pin call-outs

SWEEPING SYSTEM TROUBLESHOOTING GUIDE

Symptom

Dust control (impellor) motor will not run in the wand state

Part B: Hydraulic Load Circuit

Note: Do all testing with the engine running at high speed and the dust control switch pressed (activated).

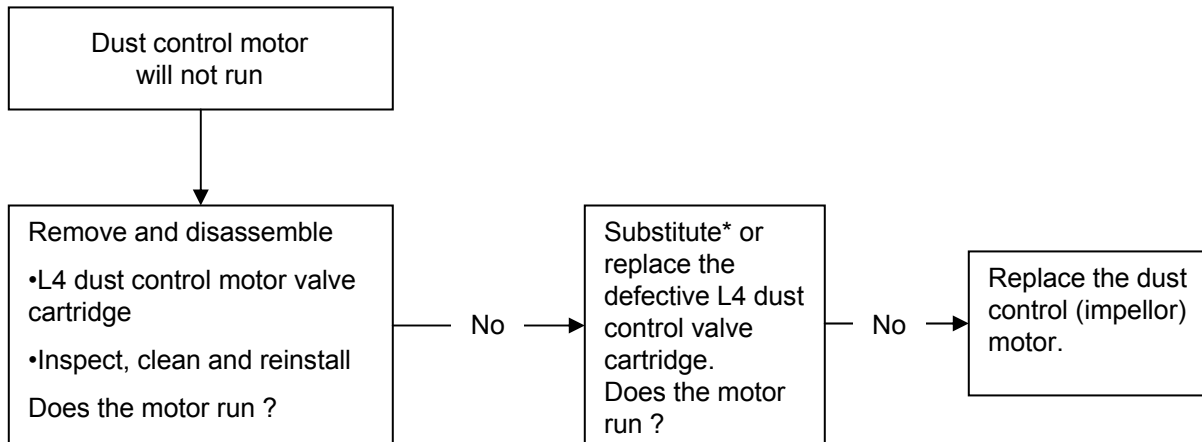

*Substitute valve cartridge numbers 1, 2 & 4 they are the same and can be swapped to help troubleshoot the system.

SWEEPING SYSTEM TROUBLESHOOTING GUIDE

Symptom

Shaker motor will not run

Part A: Electrical Control Circuit

Note: Do all testing with the key switch ON, then press the control panel shaker switch to activate turn on the shaker motor (shaker runs for approximately 15 seconds).

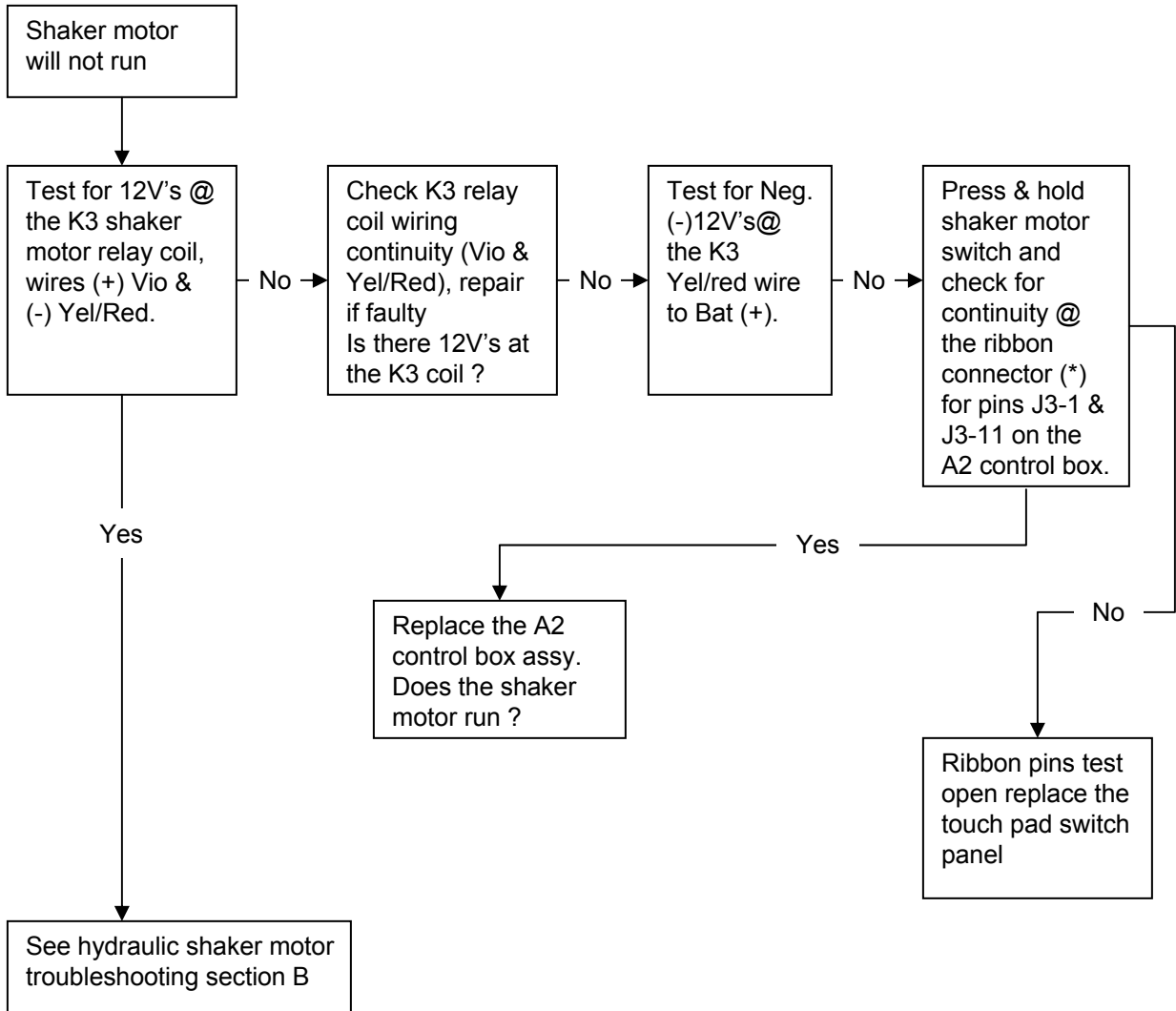

* Ribbon connector see Electrical System Figure 1 for detail pin call-outs.

SWEEPING SYSTEM TROUBLESHOOTING GUIDE

Symptom

Shaker motor will not run

Part B: Electrical Load Circuit

Note 1: Do all testing with the key switch ON, then press the control panel shaker switch to activate turn on the shaker motor (shaker runs for approximately 15 seconds).

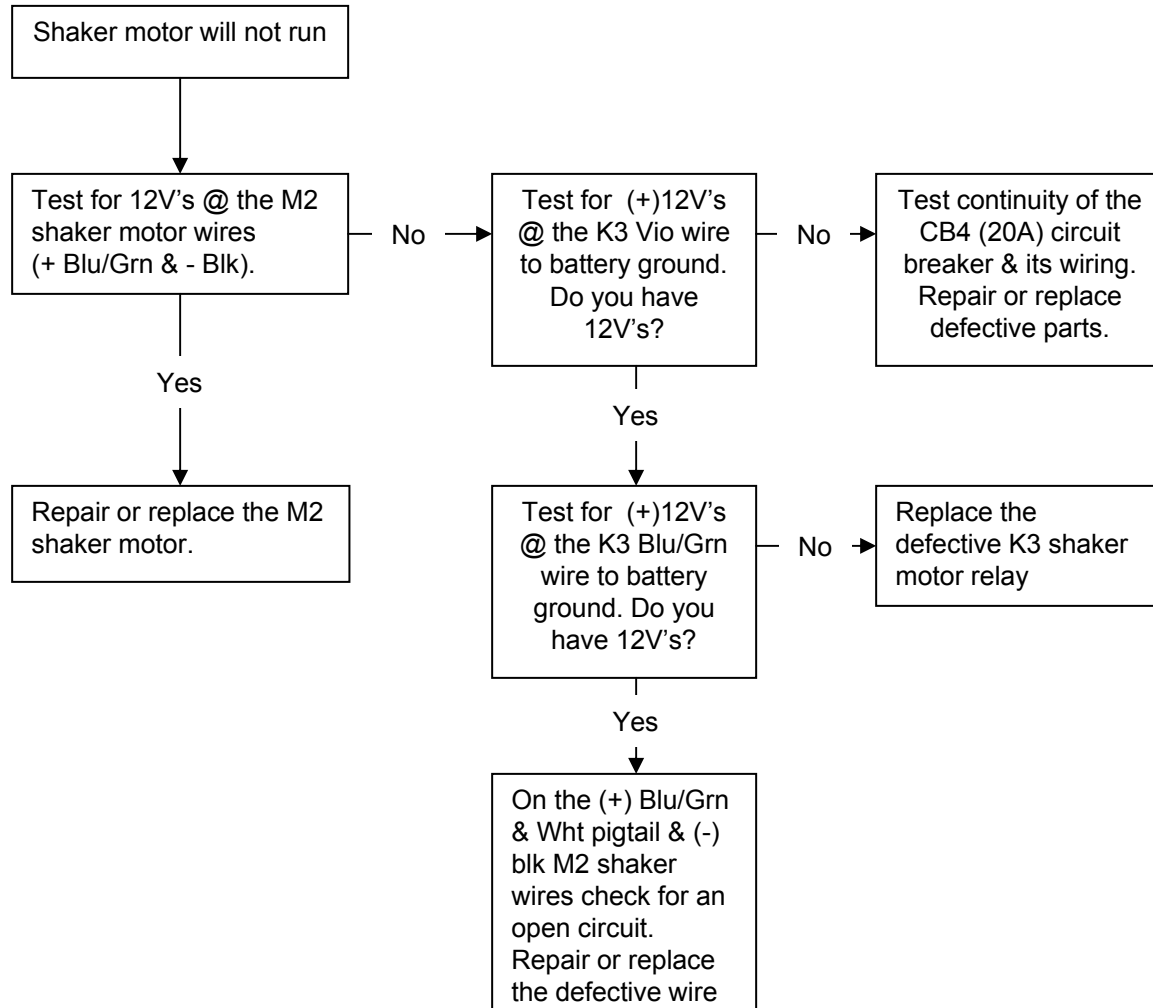

HOPPER SYSTEM TROUBLESHOOTING GUIDE

Symptom

Hopper will not raise

Part A: Electrical Control Circuit

Note: Do all testing with the engine running at high speed and the hopper raise (UP) switch pressed and held.

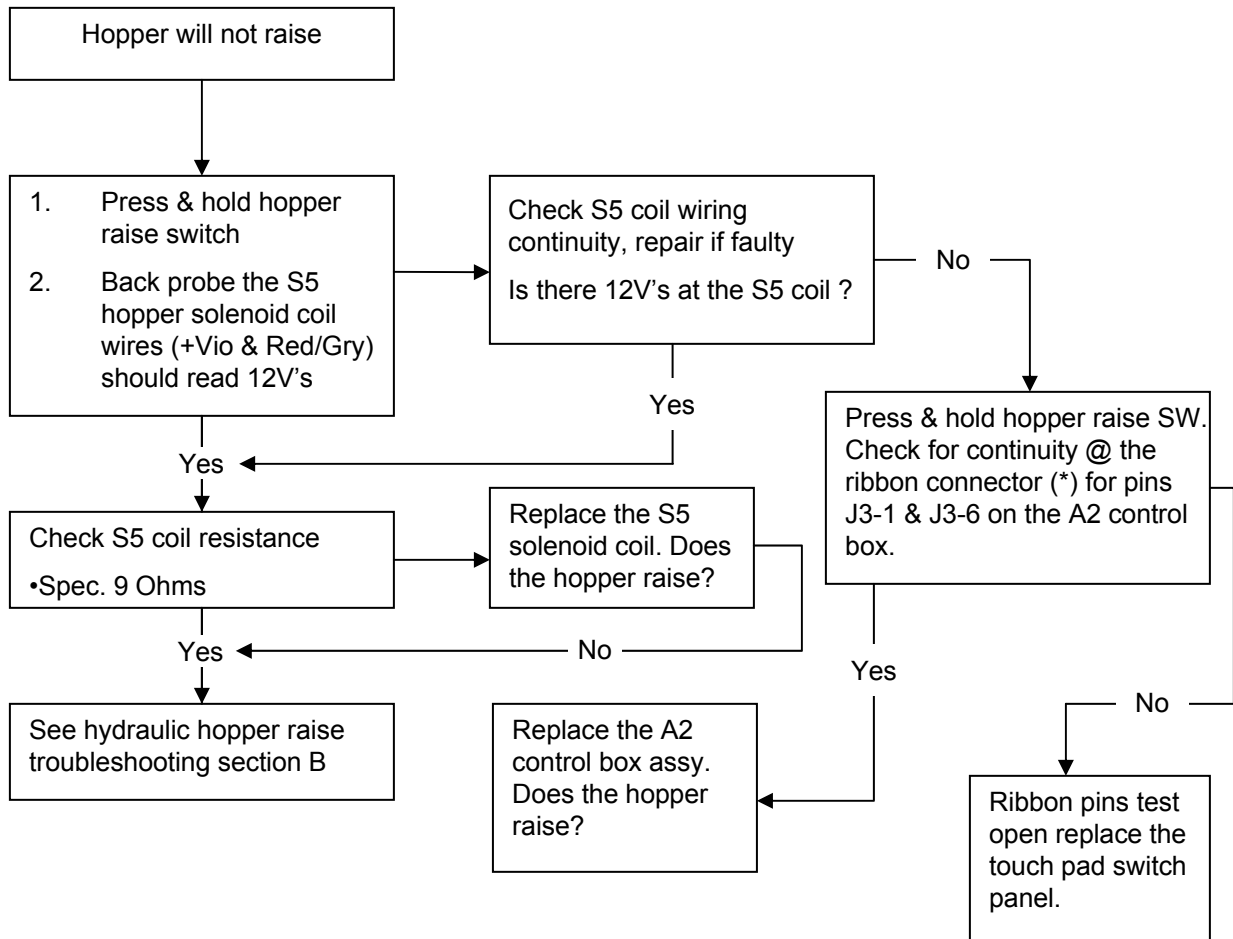

* Ribbon connector see Electrical System Figure 1 for detail pin call-outs.

HOPPER SYSTEM TROUBLESHOOTING GUIDE

Symptom

Hopper will not raise

Part B: Hydraulic Load Circuit

Note: Do all testing with the engine running at high speed and the hopper raise (UP) switch pressed and held.

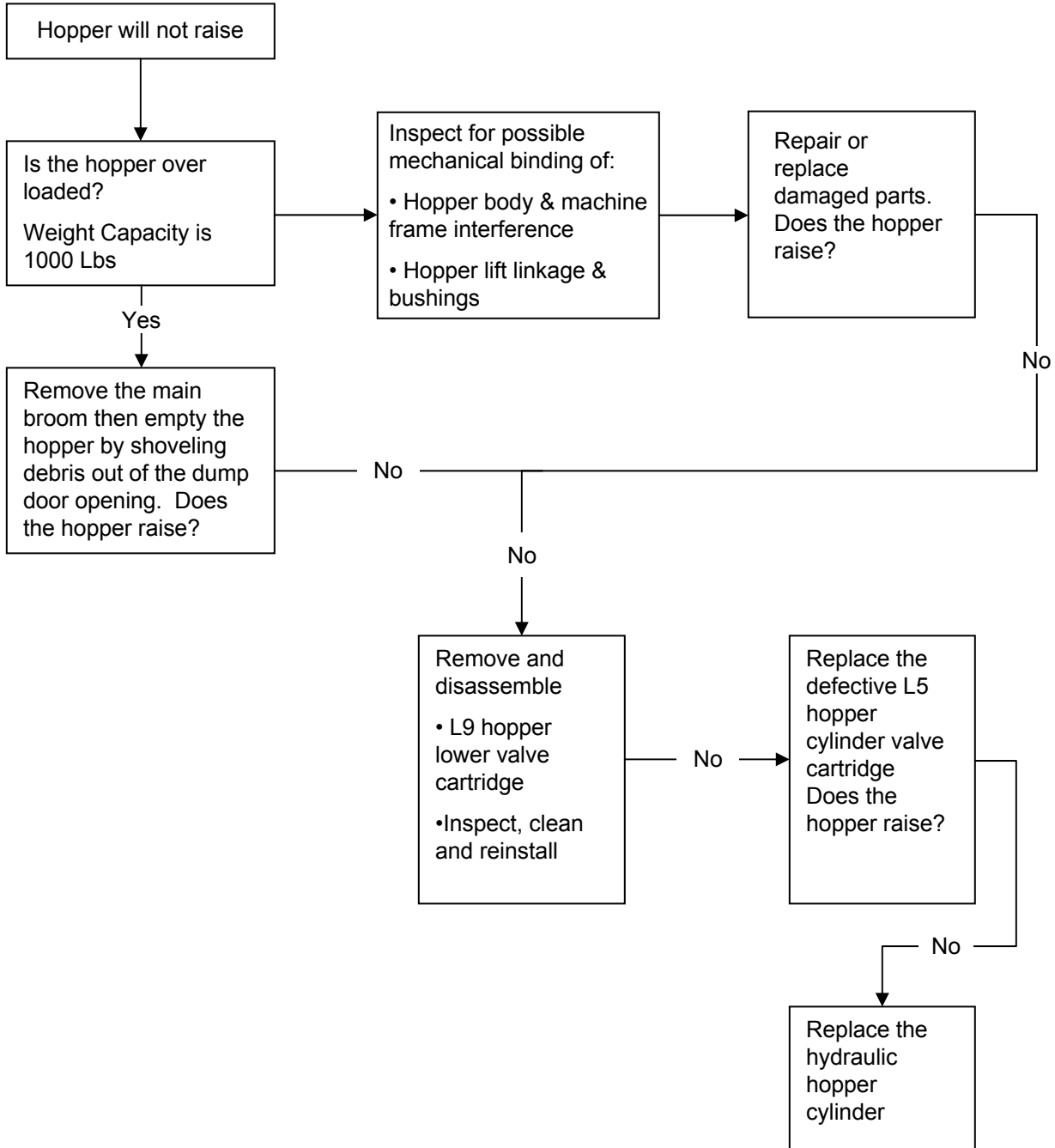

HOPPER SYSTEM TROUBLESHOOTING GUIDE

Symptom

Hopper will not lower

Part A: Electrical Control Circuit

Note: Do all testing with the engine running at high speed and the hopper lower (DN) switch pressed and held.

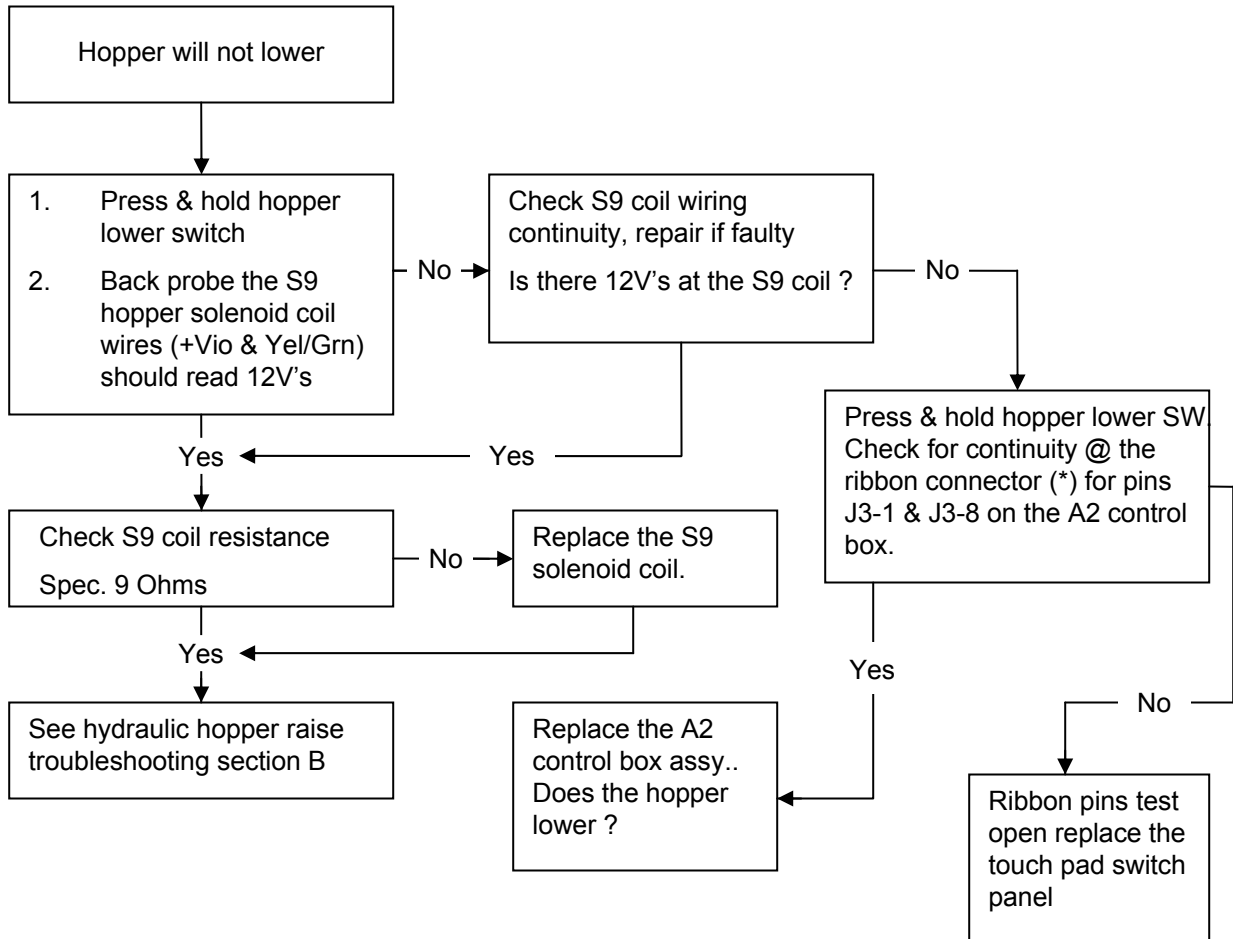

* Ribbon connector see Electrical System Figure 1 for detail pin call-outs.

HOPPER SYSTEM TROUBLESHOOTING GUIDE

Symptom

Hopper will not lower

Part B: Hydraulic Load Circuit

Note: Do all testing with the engine running at high speed and the hopper lower (DN) switch pressed and held.

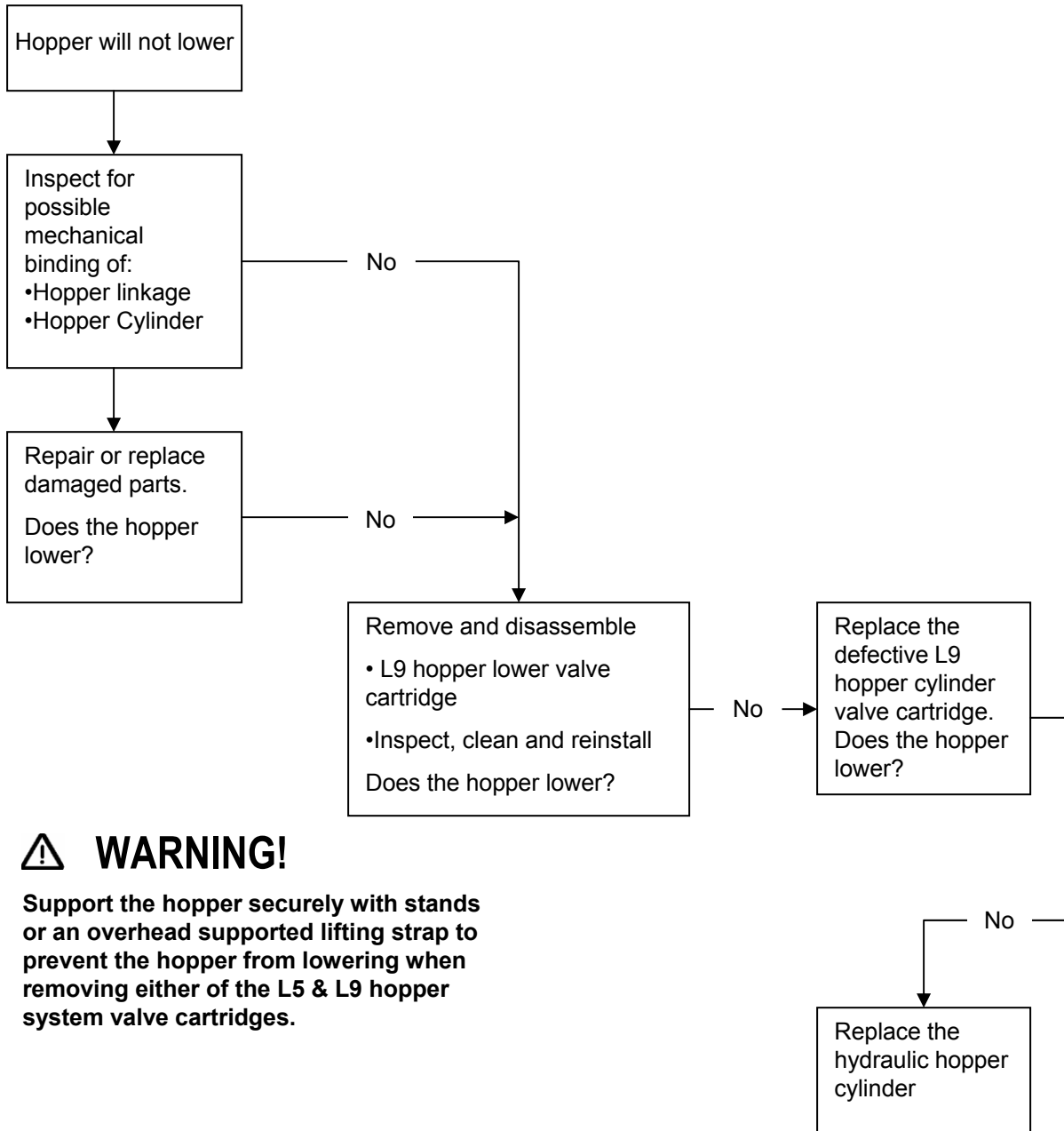

⚠ WARNING!

Support the hopper securely with stands or an overhead supported lifting strap to prevent the hopper from lowering when removing either of the L5 & L9 hopper system valve cartridges.

Note: The hopper can be lowered with the engine turned off just by pressing and holding the hopper lower switch.

HOPPER SYSTEM TROUBLESHOOTING GUIDE

Symptom

Hopper dump door will not open

Part A: Electrical Control Circuit

Note: Do all testing with the engine running at high speed and the hopper dump door open switch pressed and held.

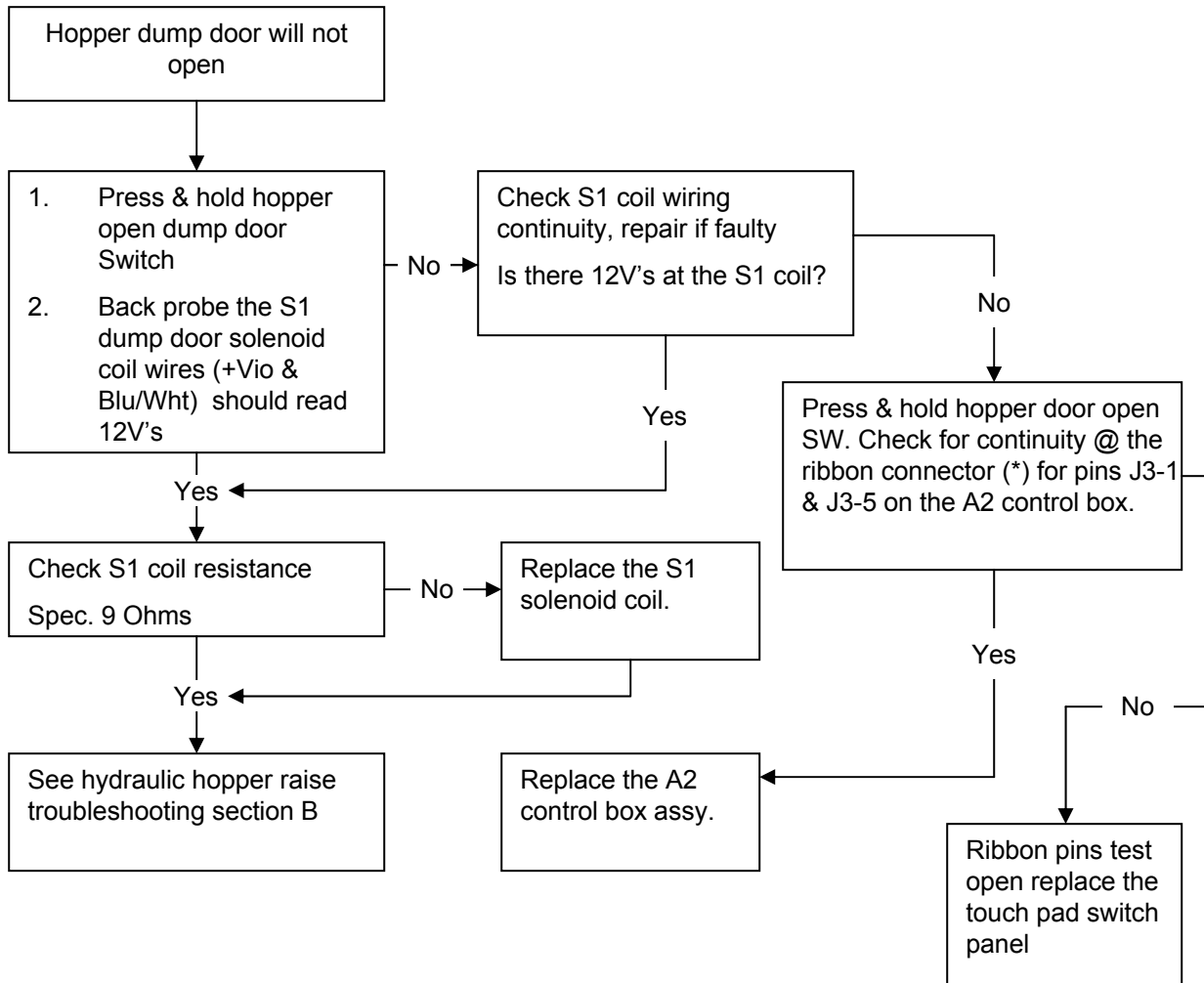

* Ribbon connector see Electrical System Figure 1 for detail pin call-outs.

HOPPER SYSTEM TROUBLESHOOTING GUIDE

Symptom

Hopper dump door will not close

Part A: Electrical Control Circuit

Note: Do all testing with the engine running at high speed and the hopper dump door close switch pressed and held.

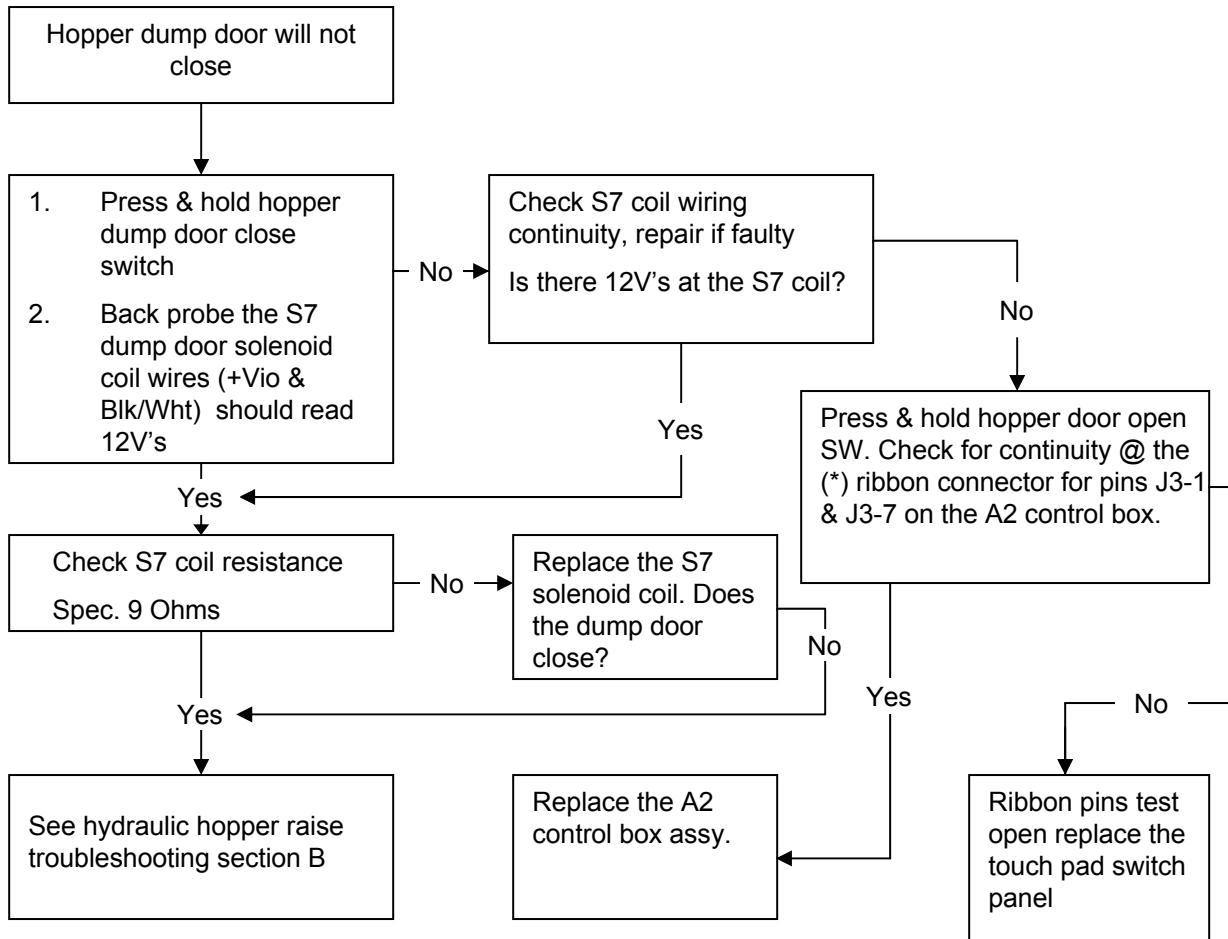

* Ribbon connector see Electrical System Figure 1 for detail pin call-outs.

HOPPER SYSTEM TROUBLESHOOTING GUIDE

Symptom

Hopper dump door will not operate open or close

Part B: Hydraulic Load Circuit

Note: To test the engine must be running at high speed and the hopper door (open/close) switches pressed and held.

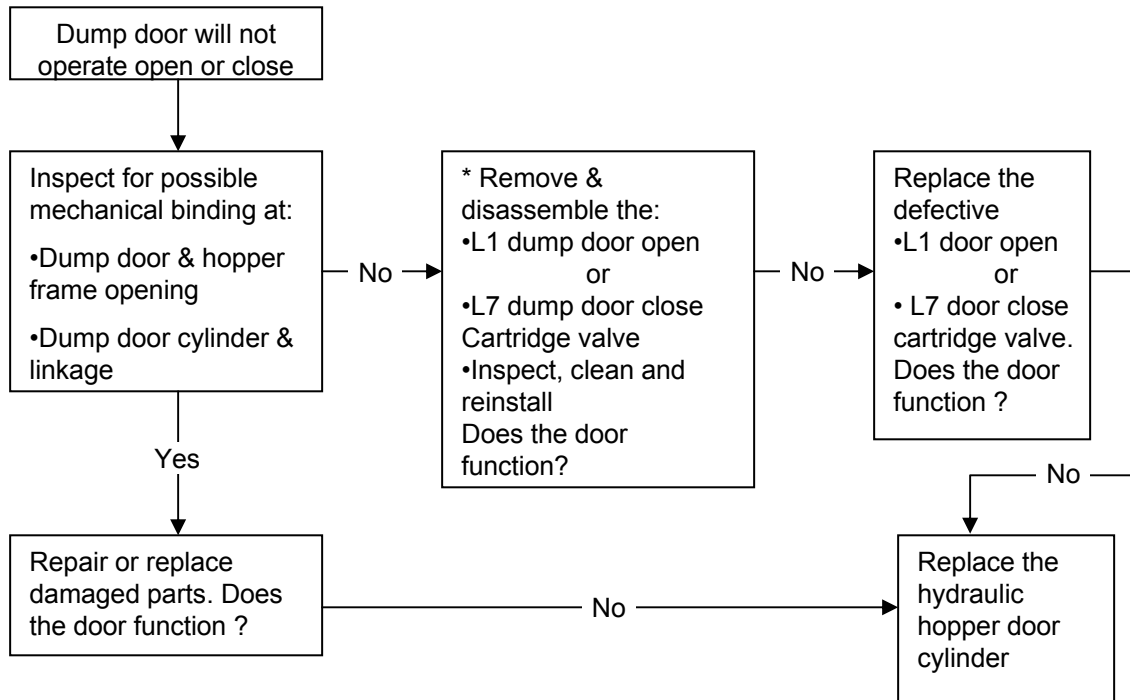

*Note: The engine must be shut off to remove and disassemble any valve cartridge.

SOLUTION SYSTEM TROUBLESHOOTING GUIDE

Symptom

Misting Pump will not Work

Part A: Electrical Control Circuit

Note 1: Do all testing with the key switch ON, misting solution tank not empty, main broom lever lowered, drive pedal activated in Fwd or Rev and the M4 misting pump's control switch S26 turned ON.

Note 2: Before T.S.check the continuity of the pump's circuit breaker CB 7 (10A), reset or replace if defective.

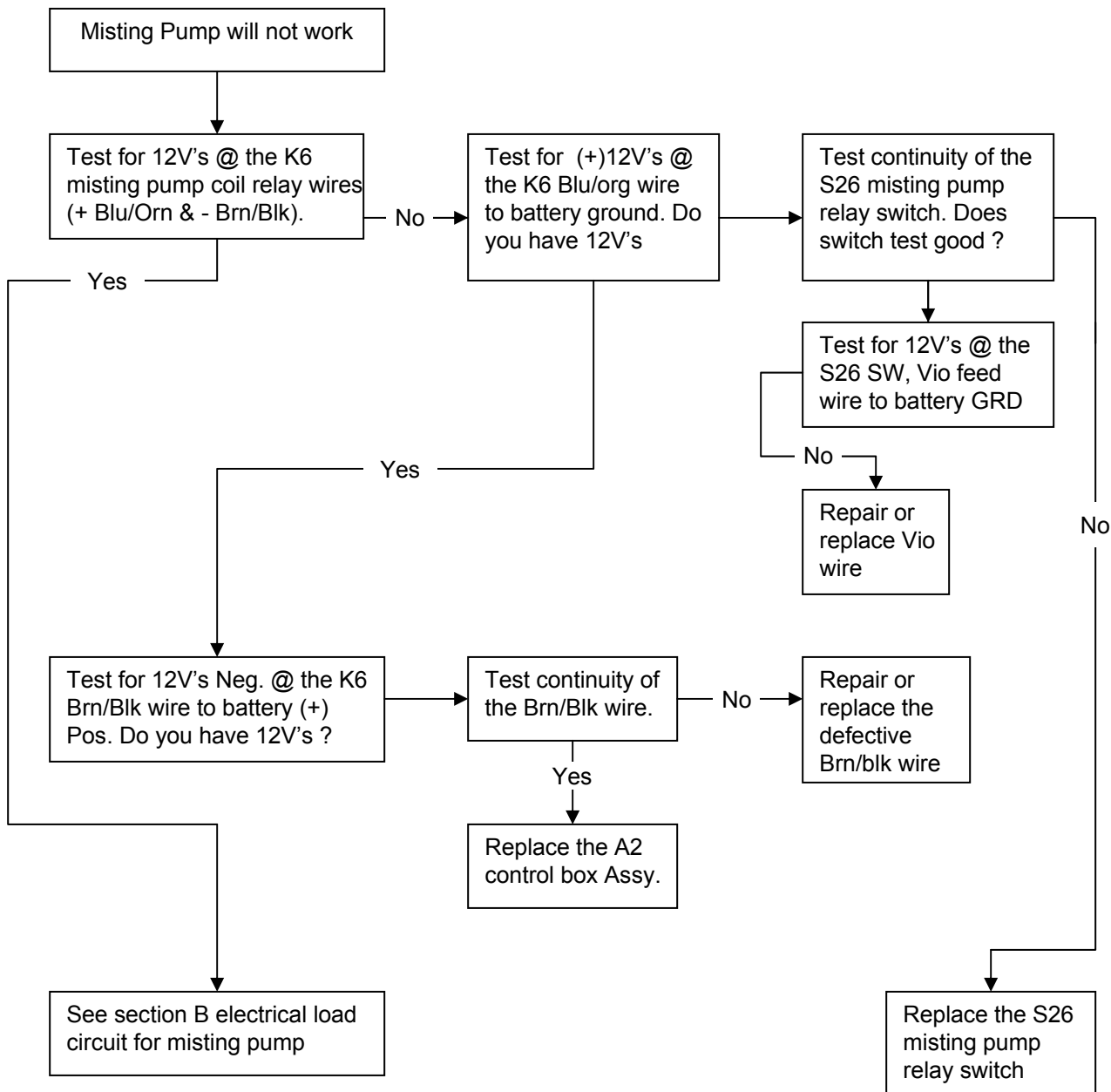

SOLUTION SYSTEM TROUBLESHOOTING GUIDE

Symptom

Misting pump will not work

Part B: Electrical Load Circuit

Note 1: Do all testing with the key switch ON, misting solution tank not empty, main broom lever lowered, drive pedal activated in Fwd or Rev and the M4 misting pump's control switch S26 turned ON.

Note 2: Before T.S. check the continuity of the pump's circuit breaker CB 7 (10A), reset or replace if defective.

Note 3: Check for plugged misting nozzles clean if needed.

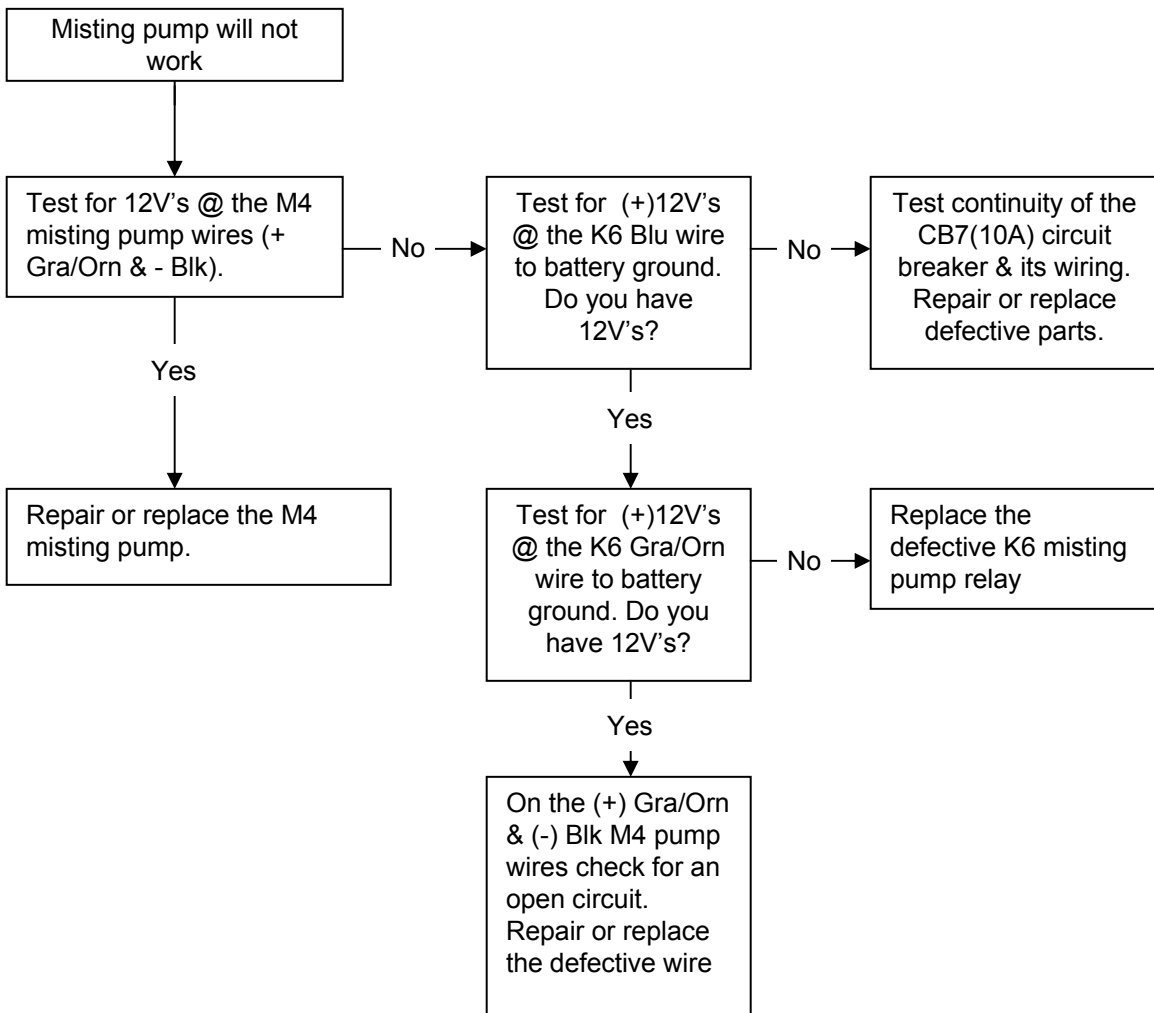

ENGINE SYSTEM

ENGINE SPECIFICATIONS

Kubota V1505-B-1

Engine Type	Vertical, water cooled, 4-cycle diesel engine
Displacement	91.41 cubic inches (1498cc)
Fuel	Diesel fuel No. 2-D (ASTM D975)
Injection Pump	Bosch MD type mini pump
Engine firing order	1-3-4-2
Injection Timing (before TDC)	19 deg.
Oil Capacity	5.5 Qts. (5.2L) / Oil Pan depth 4.9" (12.4 cm)
Cooling Capacity	8 Qts. (7.5L)
Horsepower	46 gross @2800 RPM, 41 Int @2400 RPM
Idle Speeds	Low idle 1200 RPM, High idle 2400 RPM

***NOTE:** Reference the following engine manufacturer's Service and Operators manuals for more detailed engine specifications and service data.

- Kubota Operator's Manual P.N. 16622-8916-3
- Kubota Workshop Manual P.N. 97897-01640

ENGINE OIL (DIESEL ENGINE)

Engine oil should be MIL-L-2104C or have properties of API classification CD grades or higher.

Use the information below to choose the proper engine oil for the temperature where the machine is operated most of the time.

- Above 77°F (25°C) SAE 30 or SAE 10W-30
SAE 10W-40
- 32°-77°F (0-25°C) SAE 20 or SAE 10W-30
SAE 10W-40
- Below 32°F (0°C) SAE 10W or SAE 10W-30
SAE 10W-40

Oil Filter: Use Advance P.N. 56482659

200 HRS: Change oil and replace oil filter

ENGINE FUEL FILTER (DIESEL)

400 HRS: Replace fuel filter cartridge (location before injector pump). Use Advance P.N. 56419086.

400 HRS: Replace fuel filter at electronic fuel pump.

ENGINE SYSTEM

1.6 liter GM Engine Specifications

Engine type	Liquid Cooled, 4 Cylinder, Single Overhead cam Distributor-less
Displacement	98 Cubic inches (1600 cc)
Fuel Gasoline	87 Octane Unleaded Gasoline with no more than 10% Ethanol by volume
Fuel LP	33 Lbs. Tank Size (liquid withdrawal system)
Spark Plugs	AC DELCO PN 93206675, Gap .032 -.035 (.8 mm-.9 mm)
Spark Plug wiring	Match Numbered Coil Position to Spark Plug Number (front to rear 1, 2, 3 & 4)
Engine Firing Order	1-3-4-2
Ignition Timing	Fixed (controlled by engine ECM)
Engine Rotation	CCW (flywheel end)
Valve lifters	Hydraulic
Oil Capacity	3.7 qts. (3.5L) with Oil Filter
Oil Pressure	21 PSI (minimum with engine hot at idle)
Cooling System	3.5 qts. (Engine Only)

DF 972-EZ Engine Specifications

Engine type	Liquid Cooled, 3 Cylinder, Distributor-less
Displacement	59 Cubic inches (962 cc)
Fuel Gasoline	87 Octane Unleaded Gasoline with no more than 10% Ethanol by volume
Fuel LP	33 Lbs. Tank Size (liquid withdrawal system), fuel grade HD5 (GPS Std)
Spark Plugs	NGK BKR4E, Gap .024 -.028 (.6 mm -.7 mm)
Spark Plug wiring	Combined plug wiring & coil assembly (Qty 3)
Engine Firing Order	1, 2, 3 from the front of engine (cooling fan)
Ignition Timing	Fixed (controlled by engine spark ignition module)
Engine Rotation	CCW (flywheel end)
Valve lifter clearance	.0065 - .008 (.165 +/- .02 mm)
Oil Capacity	3.6qts. (3.4) with Oil Filter
Oil Pressure	7 PSI (minimum with engine hot at idle)
Cooling System	"NA" qts. (Engine only)

ROUTINE ENGINE MAINTENANCE

- Keep the fuel tank filled. This helps to reduce condensation and moisture entering the fuel system (gasoline).
- Make daily checks of the engine oil and coolant levels.
- Repair any oil or coolant leaks immediately.
- Check condition of battery (water level) and cables weekly.
- Keep the engine air filter clean.
- Observe the engine coolant temperature gauge frequently.
- Observe the engine oil pressure gauge frequently.
- Check the voltmeter and charging system.

ENGINE SYSTEM

CHECK ENGINE LIGHT TROUBLESHOOTING FOR 1.6L GM ENGINE

The engine ECM will light (turn on) the dash panel (**UU**) check engine light if there is a problem associated with the computerized engine control system.

The following steps explain how to correctly access the engine controller's fault code outputs.

- 1 On the operator display panel the engine check light (MIL ) comes on steady will not shut off.
- 2 Locate the 8 way ECM communication test port, which is a part of the engine wiring harness.
- 3 Next remove the test port protective cap. See Figure 2. Insert a suitable jumper wire across pin "1" (black/green wire) & pin "4" (orange wire).

Blink Code Function

Although the DST (Diagnostic Service Tool software) is considered a required tool to access the DTC codes, codes may be retrieved without a laptop computer using the blink code function. To enable this function follow the steps below:

- 4 Turn the ignition key to the on position.
- 5 The system will now enter the self diagnostic blink code mode. Be ready with pen and paper to write down any codes that may be stored.
- 6 The ECM will flash the MIL indicator with a pause between represented numbers that represent DTC codes. The sequence starts with code 1654. Code 1654 confirms the system has entered the blink code mode. The ECM will flash code 1654 (3) times before displaying the actual DTC code that may be set.

Example:

One short blink (pause) six short blinks (pause) five short blinks (pause) four short blinks.

- If no DTC codes are found, the ECM will continue to flash 1654 only. This means no stored DTC codes were found.

FIGURE 2

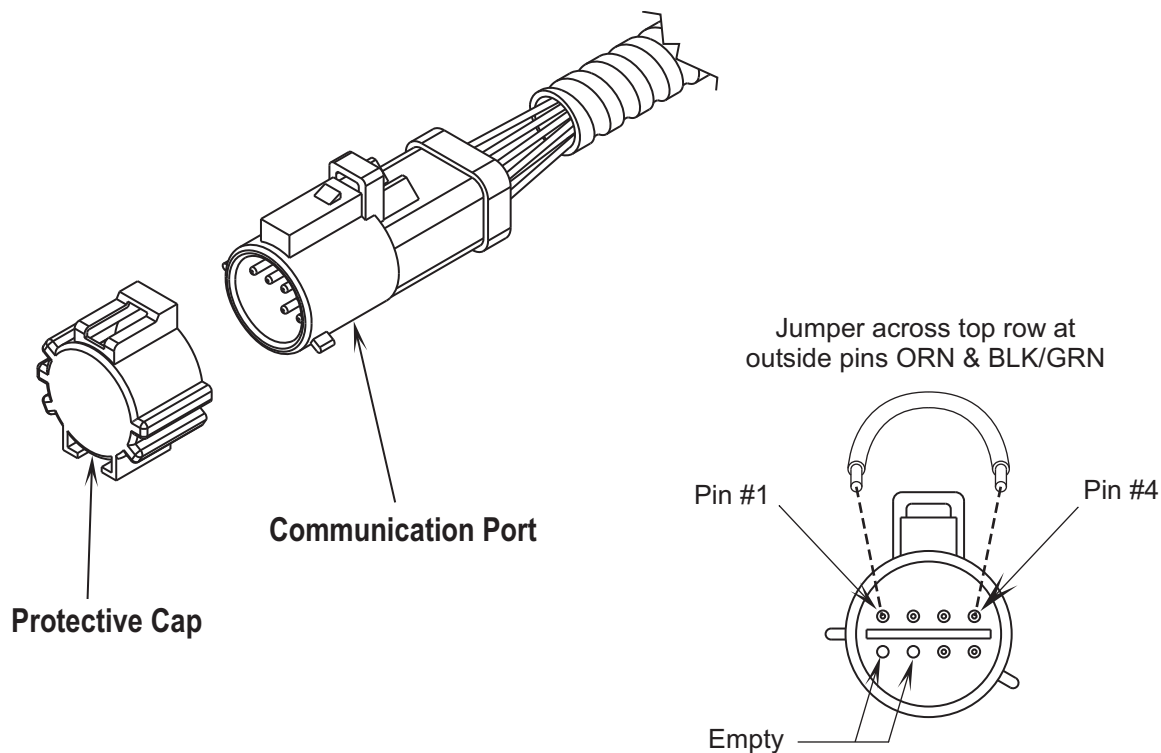

ENGINE SYSTEM

1.6L DTC Code to SPN:FMI Code Cross Reference

DTC Code	Description	SPN Code	FMI Code
16	Crank Never Synced at Start	636	8
91	Fuel Pump Low Voltage	94	4
92	Fuel Pump High Voltage	94	3
107	MAP Low Voltage	106	4
108	MAP High Pressure	106	16
111	IAT Higher Than Expected 1	105	15
112	IAT Low Voltage	105	4
113	IAT High Voltage	105	3
116	ECT Higher Than Expected 1	110	15
117	ECT Low Voltage	110	4
118	ECT High Voltage	110	3
121	TPS 1 Lower Than TPS 2	51	1
122	TPS 1 Signal Voltage Low	51	4
123	TPS 1 Signal Voltage High	51	3
127	IAT Higher Than Expected 2	105	0
129	BP Low Pressure	108	1
134	EGO 1 Open/Inactive	724	10
154	EGO 2 Open/Inactive	520208	10
171	Adaptive Learn High Gasoline	520200	0
172	Adaptive Learn Low Gasoline	520200	1
182	Fuel Temp Gasoline Low Voltage	174	4
183	Fuel Temp Gasoline High Voltage	174	3
187	Fuel Temp LPG Low Voltage	520240	4
188	Fuel Temp LPG High Voltage	520240	3
217	ECT Higher Than Expected 2	110	0
219	Max Govern Speed Override	515	15
221	TPS 2 Signal Voltage Low	51	0
222	TPS 2 Signal Low Voltage	520251	4
223	TPS 2 Signal High Voltage	520251	3
336	Crank Sync Noise	636	2
337	Crank Loss	636	4
420	Gasoline Cat Monitor	520211	10
524	Oil Pressure Low	100	1
562	System Voltage Low	168	17
563	System Voltage High	168	15
601	Flash Checksum Invalid	628	13

DTC Code	Description	SPN Code	FMI Code
604	RAM Failure	630	12
606	COP Failure	629	31
642	External 5V Reference Low	1079	4
643	External 5V Reference High	1079	3
685	Power Relay Open	1485	5
686	Power Relay Shorted	1485	4
687	Power Relay Short to Power	1485	3
1111	Fuel Rev Limit	515	16
1112	Spark Rev Limit	515	0
1151	Closed Loop Multiplier High LPG	520206	0
1152	Closed Loop Multiplier Low LPG	520206	1
1155	Closed Loop Multiplier High Gasoline	520204	0
1156	Closed Loop Multiplier Low Gasoline	520204	1
1161	Adaptive Learn High LPG	520202	0
1162	Adaptive Learn Low LPG	520202	1
1165	LPG Cat Monitor	520213	10
1171	LPG Pressure Higher Than Expected	520260	0
1172	LPG Pressure Lower Than Expected	520260	1
1173	EPR Comm Lost	520260	31
1174	EPR Voltage Supply High	520260	3
1175	EPR Voltage Supply Low	520260	4
1176	EPR Internal Actuator Fault	520260	12
1177	EPR Internal Circuitry Fault	520260	12
1178	EPR Internal Comm Fault	520260	12
1612	RTI 1 Loss	629	31
1613	RTI 2 Loss	629	31
1614	RTI 3 Loss	629	31
1615	A/D Loss	629	31
1616	Invalid Interrupt	629	31
1626	CAN Tx Failure	639	12
1627	CAN Rx Failure	639	12
1628	CAN Address Conflict Failure	639	13
2111	Unable to Reach Lower TPS	51	7
2112	Unable to Reach Higher TPS	51	7
2229	BP Pressure High	108	0

ENGINE SYSTEM

MISCELLANEOUS ENGINE SYSTEM INFORMATION

Additional Engine Troubleshooting Symptom

Engine Overheating

Use the checklist below as a guide, to thoroughly check the engine cooling system.

- Check coolant level in overflow tank and radiator.
- Inspect and clean radiator and hydraulic oil cooler.
- Check for proper operations of the belt driven engine cooling fan (slippage).
- Check to see that the engine thermostat opens.
- Check for proper operation of water pump.
- Check engine crankcase oil level.

Over Temperature Protection: The GM 1.6L engine will set a diagnostic test code (DTC 116) after 5 sec. at temperatures over 215 °F and a power derate level one will be enforced. This engine fault will limit the maximum throttle position to 50%. With further overheating the engine will set a code (DTC 217) after 10-15 sec. at temperatures over 225 °F and the engine will then shut down.

Loss of Oil Pressure Protection: Engine shutdown if oil pressure is only 3-7 PSI.

4 Cylinder Engine G/P/D Speed Settings

Fast Engine Speed 2400 RPM

Idle Engine Speed 1200 RPM

3 Cylinder Engine G/P Speed Settings

Fast Engine Speed 2800 RPM

Idle Engine Speed 1500 RPM

GM 1.6L GASOLINE FUEL SYSTEM DESCRIPTION

This engine is equipped with a fuel injector rail that does not have a pressure regulator. Fuel pressure for this engine is regulated by the engine's ECM controlling the fuel pump via pulse width modulation. The ECM receives fuel pressure and temperature feedback from the gasoline fuel sensor manifold and uses this information to control the ground side of the fuel pump. Fuel pressure is regulated by the ECM pulse width modulating (PWM) the fuel pump. The fuel pressure and temperature sensor manifold has a return or "bleed" circuit that is comprised of a .020" orifice and a 6 psi check valve that connects back to the equipment fuel tank. This circuit is used to bleed off any vapor that develops in the line and returns a small amount of fuel to the tank. The fuel comes from the fuel tank and passes through the inline fuel pump. Fuel exits the fuel pump, passes through the filter and then enters the fuel pressure and temperature manifold assembly. Fuel flows through the feed circuit and is delivered to the fuel injector rail. Fuel that enters the bleed circuits through the by-pass valve in the manifold is returned to the fuel tank.

ENGINE SYSTEM

FIGURE 3

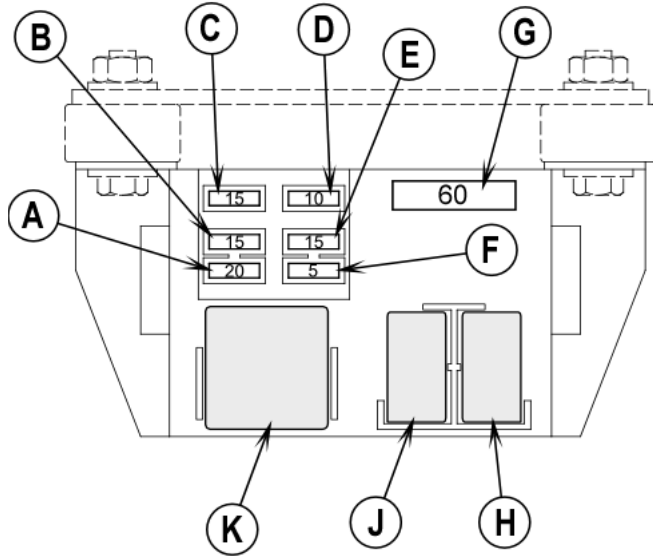

Engine Fuse Box

- A** - F2 20 Amp Fuse for:
 - ECM input
- B** - F4 15 Amp Fuse for
 - ignition
- C** - F6 15 Amp Fuse for
 - starter relay coil
- D** - F3 10 Amp Fuse for:
 - EPR
- E** - F5 15 Amp Fuse for:
 - Fuel Pump relay coil
- F** - F1 5 Amp
 - VSW
- G** - 60 Amp Maxi-Fuse
 - alternator power relay coil
- H** - Power Relay Alternator
- J** - Fuel Pump Relay
- K** - Engine Starter Relay

FIGURE 4

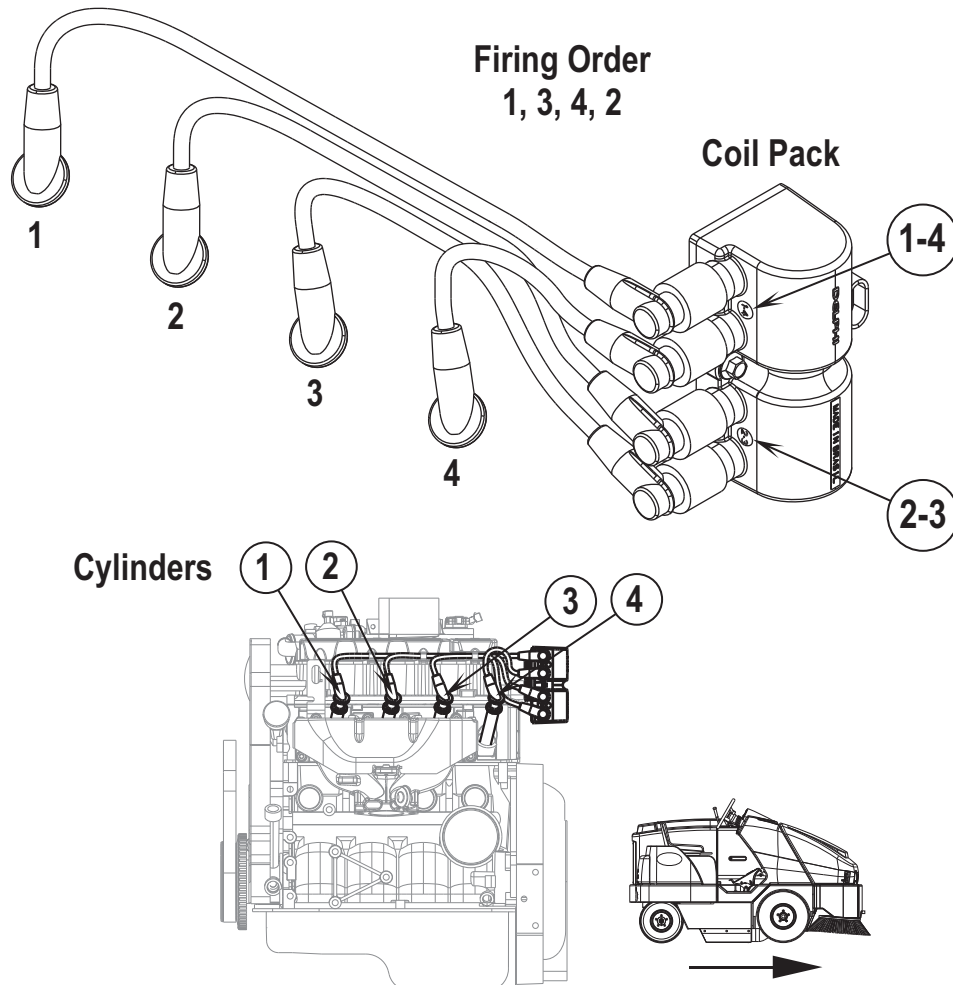

ENGINE SYSTEM

3 CYLINDER KUBOTA REPLACEMENT OF THE ENGINE THROTTLE ACTUATOR

Removal:

- 1 **See Figure 5.** Loosen the actuator throttle cable Anchor Hardware **(A)** and also loosen the wire cable end connection Screw **(B)** as shown.
- 2 Remove the P-clamp **(C)** at the radiator shroud that is used to route the cable.
- 3 Note the location of the actuator wiring harness wire connections at the bottom of the Actuator Control Module **(D)** for correct reassembly, then remove the wiring (see Figure 6).
- 4 Remove the (4) hex head Screws **(E)** that secure the actuator at its mounting plate and complete the removal of the actuator/cable assembly from the engine.

Installation: Follow the above removal steps in reverse to install the new actuator.

Actuator Throttle Speed Adjustment:

Start the engine and run engine to its normal operating temperature. Use a digital tachometer to check and set the correct engine idle and high speed running specification. Place the tachometer target tape onto the engine crankshaft pulley and aim the meter to pick up the crankshaft speed.

WARNING!

When checking the engine RPM do not allow any loose clothing, hands, tools or test instrument to make contact with the moving engine fan, pulleys and belt.

Reference Figure 5 that shows the Idle Adjustment Screw **(F)**. The 3 cylinder Exterra's engine idle speed is to be set at 1500 RPM + or – 20 RPM. Adjust to the correct speed using a small Phillips screwdriver.

To set the high speed setting first loosen the Lock Nut **(G)** as shown at the actuator then turn the large adjustment sleeve in or out to 2800 RPM + or – 20RPM. Turn the nut CCW to increase the RPM and CW to lower the RPM. Double check both speeds to confirm the correct settings then tighten the lock nut at the actuator. Note also check the other end of the cable Wire Screw **(B)** that it is tight, preventing the cable from loosening and slipping out of adjustment.

ENGINE SYSTEM

FIGURE 6

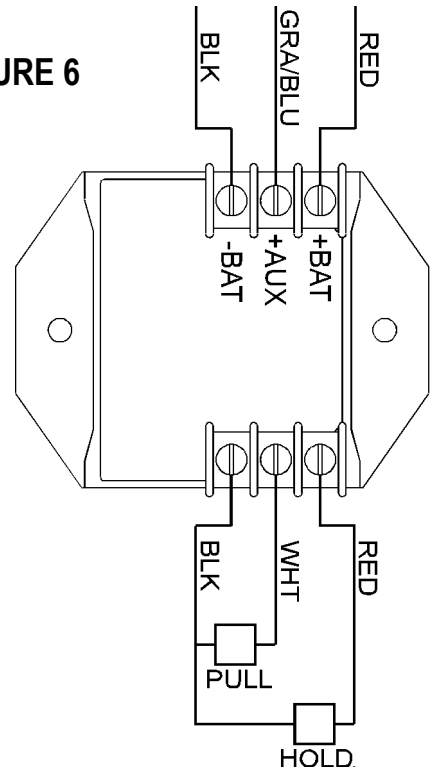
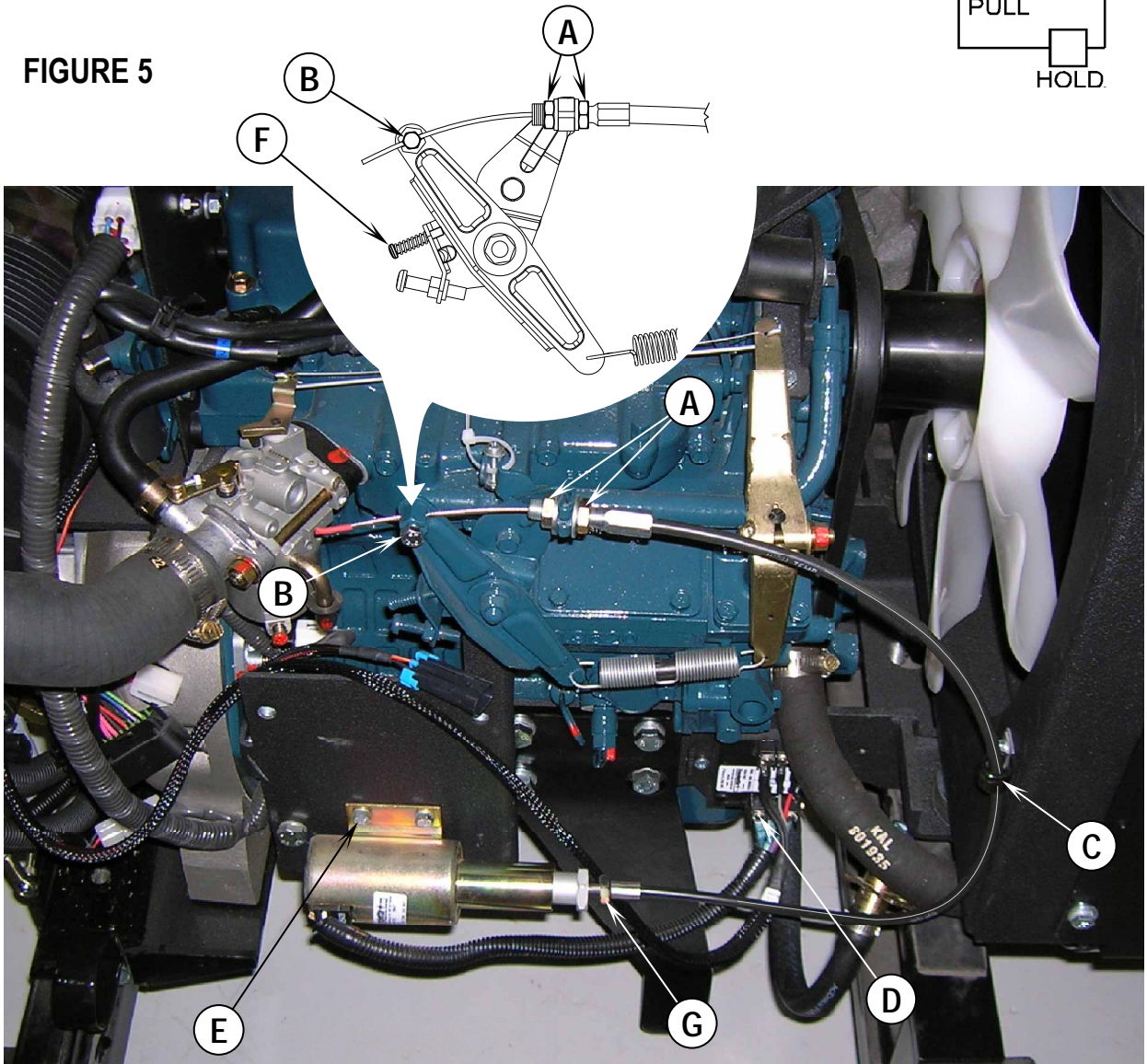

FIGURE 5



HYDRAULIC SYSTEM

HYDRAULIC SYSTEM TROUBLESHOOTING

Accurate measurements are the key to troubleshooting a hydraulic system. Once measurements are obtained, they can be compared with specifications to analyze a problem.

To troubleshoot the hydraulic system it is possible to use digital tachometers, flow gauges or pressure gauges. The pressure gauge should have a range of 0 – 3000 PSI (see Figure 2) and have a Parker Diagnostics connector number PD222. The most convenient way to check for oil flow is to check the RPM of the motor that is performing poorly. Use the chart on the next page to determine the motor RPM, if the motor speed is correct the pump is producing the correct amount of oil flow. However, this does not mean that, if a motor is running too slow the problem is in the pump.

The following information should be used to check for proper motor RPM, system pressure and relief valve settings. The readings are nominal figures and there will be variations due to manufacturer tolerances and system oil temperature. If any reading varies greater than 20% there will be a noticeable loss of performance and should be corrected.

TEST PORT NOMINAL PRESSURE READINGS (see Figure 1)

- Insert pressure gauge (see Figure 1) into the test port.
- Run engine in high throttle position. Allow oil to warm up.
- The bypass pressure is the pressure reading with no motor or cylinder operating.
- The operational pressure is the pressure range the motor or cylinders will operate in.

FIGURE 1

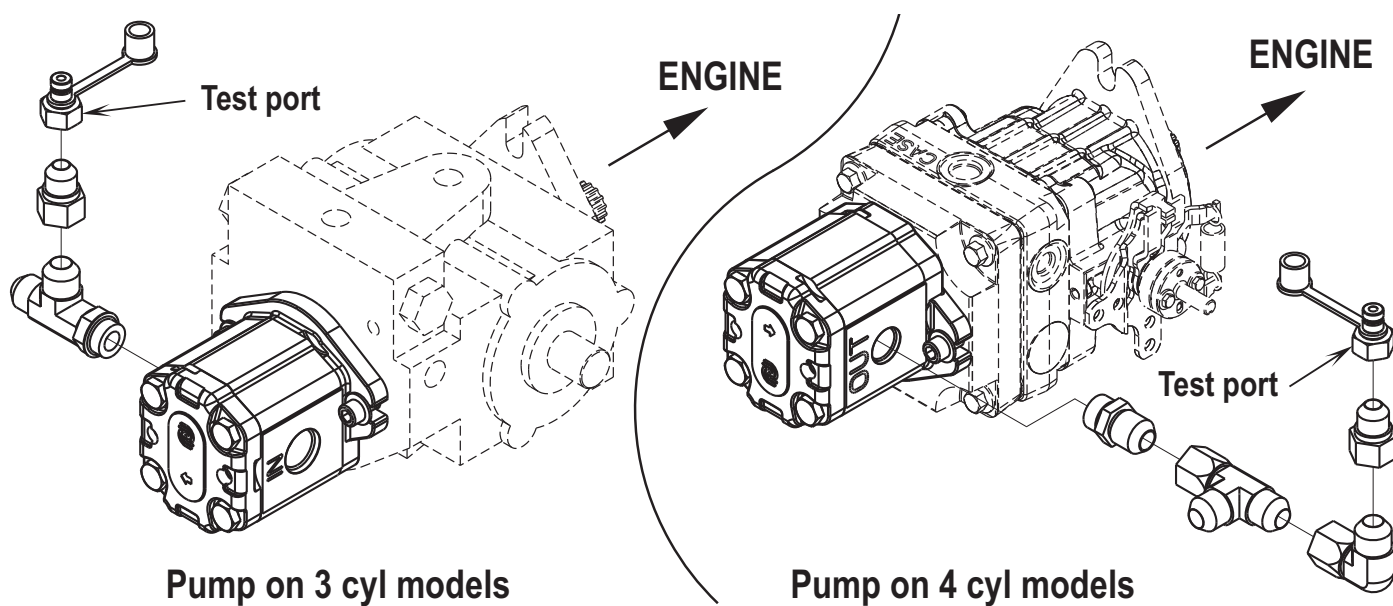

Note: 100 PSI = 6.9 bar

- A much lower than normal bypass pressure could indicate a gear pump problem.
- If the bypass pressure remains the same after turning the function on, there could be a problem in the control valve or circuit.
- If the operational pressure is within range but the motor speed is too slow the problem could be in the motor.
- If the broom motor Operational PSI reading is above the Bypass PSI but is below the Operational PSI check the broom adjustment and wear.
- Check individual system troubleshooting sections of this manual for additional information.

FIGURE 2

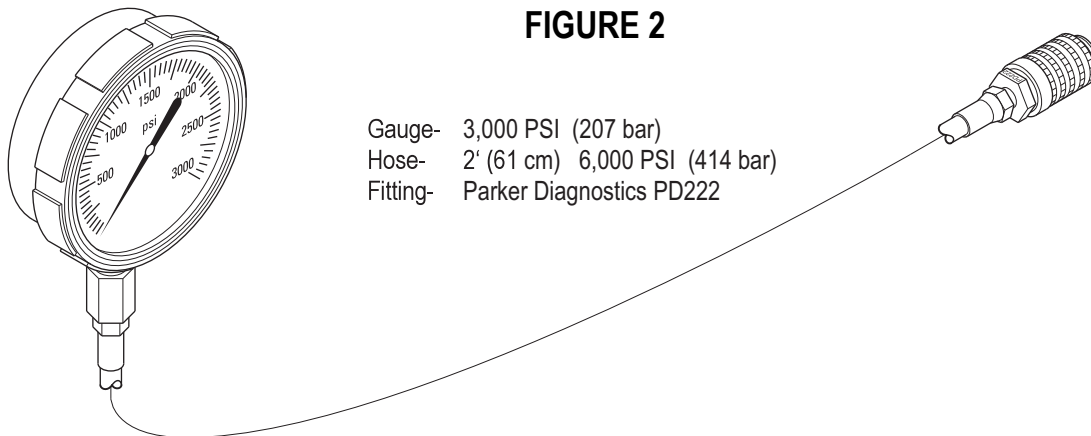

Gauge- 3,000 PSI (207 bar)
 Hose- 2' (61 cm) 6,000 PSI (414 bar)
 Fitting- Parker Diagnostics PD222

HYDRAULIC SYSTEM GENERAL HYDRAULIC SPECIFICATIONS TABLE

Pump & Motor Circuits for 3 cylinder models	DISPL in ³	GPM	RPM (in)	RPM (out)	PSI	Relief PSI
Auxillary Pump Circuit Engine @ 2800rpms No systems running	.88	10.6	2800		*380	2500
Main Broom @ sweep position (Std Broom with a 2.0" pattern). Wet sweep Bypass (dust control off) & side broom(s) off.	2.45	5.7	2800	405	1275	2500
Dust Control Impeller On, machine high, all systems running	.161	5.7	2800	8900	1800	2500
Dust control Impeller On, machine high, all systems off	161	5.7	2800	8900	1650	2500
1 Side Broom (right) machine high, all systems running	6.1	2.9	2800	130	425	2500
2 Side Brooms machine high, all systems running	6.1	2.9	2800	105	360	2500
Dump Door (open/close time 2 – 3 sec.) nothing else running			2800		Open20Close/50	
Hopper Lift (raise time 10/11 sec.) Empty			2800		2875	
Hopper Lift (lower time 7 sec.) Empty					380	
Steering System	4.88	2.0	2800		150	**1100
Propulsion Pump Circuit for 3 cylinder models						
Hydrostatic pump	1.33	16.12	2800			2900
Wheel Motor@ 6.7mph level ground, smooth concrete, no systems running, full speed forward	15.9	7.5		Fwd170 Rev 90	**350 - 475	
Hydrostat Charge					65	
Pump Circuit for 4 cylinder models						
Auxillary Pump Circuit Engine @ 2400rpms No systems running (XT1)	1.02	10.6	2400		*380	2500
All other accessory components use the 3 cylinder data						
Propulsion Pump Circuit for 4 cylinder models						
Hydrostatic pump	2.48	25.7	2400			3000
Wheel Motor@ 6.7mph level ground, smooth concrete, no systems running, full speed forward	22.8	16.7		Fwd170 Rev 90	**600 - 700	
Hydrostat Charge					100	

* The bypass pressure is the pressure reading with no motor or cylinder operating (flow through).

** Test conditions 70 degrees F, empty hopper, pedal ½ depressed & fully depressed.

Note: Pressure measurements taken at test Port XT1 location output of the accessory pump

HYDRAULIC SYSTEM

Hydraulic Truth Table

Electrical Solenoid's energized Status

Solenoid Functions	S1	S2	S3	S4	S5	S6	S7	S8	S9
Hopper Raise (UP)					X	X			
Hopper Lower (DN)									X
Dump Door Open	X								
Dump Door Closed							X		
Main Broom State ON		X				X			
Main /Side Broom State ON		X	X			X			
Dust Control ON Wand State (**)				X		X			
Dust Control OFF Bypass (*)								X	
Side Broom Lower			X						
Side Broom Raise & turn OFF side broom motor			0V						
No Hydraulic Manifold Functions	System overloaded in relief					S6 not energized (***)			

Notes:

* Operator sweeping wet debris with the dust control fan (impeller) turned off.

** Operator using vacuum wand option. The dust control fan operates with the machines drive stationary. To vacuum attach the suction hose wand to the special hopper inlet fitting.

*** The S6 solenoid valve assembly bypasses the sweep system components and sends its hydraulic oil flow to tank when S6 is de-energized (0 volts).

HYDRAULIC MANIFOLD ASSEMBLY COMPONENT LOCATION KEY

Note: the combined electrical solenoid and hydraulic valve cartridge assembly can be serviced separately.

Item #	Component Description & Hydraulic Circuit Function
S1	Solenoid coil & valve cartridge, hopper dump door (open), coil 8 Ohms
S2	Solenoid coil & valve cartridge, main broom System, coil 8 Ohms
S3	Solenoid coil & valve cartridge, side broom system, coil 8 Ohms
S4	Solenoid coil & valve cartridge, dust control (wand state), coil 8 Ohms
S5	Solenoid coil & valve cartridge, hopper lift system (raise), coil 8 Ohms
S6	Solenoid coil & valve cartridge, hydraulic circuit on/off (by-pass), 8 Ohms
S7	Solenoid coil & valve cartridge, hopper Dump door (close), coil 8 Ohms
S8	Solenoid coil & valve cartridge, dust control fan off (by-pass), coil 6 Ohms
S9	Solenoid coil & valve cartridge, hopper lift (close), coil 8 Ohms

Notes: (A) The solenoid coils w/connector S1 – S7 & S9 are identical and can be swapped for (T.S.) troubleshooting. (B) The solenoid coil w/connector S8 is different only one is used. (C)The valve cartridges for S1, S2 & S4 are identical, S3 & S7 the same and S5 & S9 the same and can be swapped for T.S. (D)The S6 & S8 valve cartridges are different configurations one of each are only used.

Item #	Additional Hydraulic Manifold Components Descriptions
X1	Cartridge, side broom lift cylinder piloted 3/2 directional valve
X2	Cartridge, side broom piloted check valve
X3	Orifice (.038 Dia.), hopper raise control
X4	Orifice (.086 Dia.), hopper dump door control
X5	Orifice (.078 Dia.), hopper lower control
X6	Cartridge, broom system flow divider
X7	Cartridge, steering system flow divider
X8	Check valve, side broom(s)
X9	Cartridge, hopper lift free check
X10	Pressure relief valve (2500 PSI.), manifold block

HYDRAULIC SYSTEM

FIGURE 3

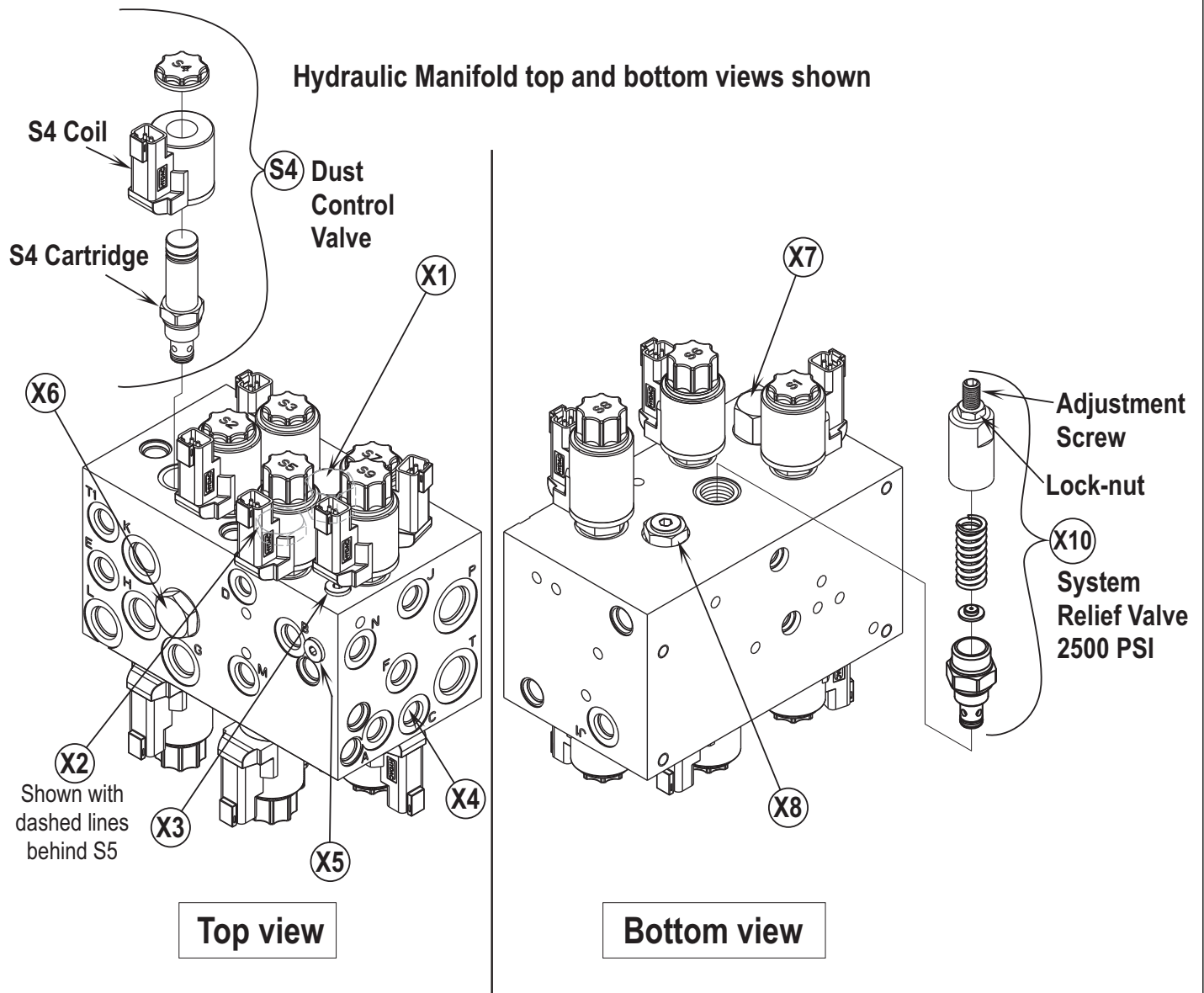

HYDRAULIC SYSTEM PRESSURE RELIEF VALVE

Instructions for testing and adjusting the main pressure relief valve that is built into the machines hydraulic manifold assembly:

Insert hydraulic test gauge (3000 psi.) to the XT1 test port (location between pump & solenoid manifold).

To check pressure the hydraulic oil must be warm & engine at high speed (2400 RPM 4 cylinder models & 2800 RPM 3 cylinder models).

Activate the hopper lift (raise or lower) to dead head its cylinder to place the pump circuit into an overloaded condition.

CAUTION!

Do not test in the overloaded condition for a long period as this may cause damage (excessive heat build up).

Observe the pressure gauge reading in the overloaded (dead headed) position and adjust accordingly. The hydraulic systems relief setting is 2500 PSI. for all the 3 & 4 cylinder engines. See Figure 3. Loosen lock-nut turn adjustment screw CCW to decrease & CW to increase.

HYDRAULIC SYSTEM

Hydraulic System 3-Cylinder models

Item Description

- 1 Steering Control Unit
- 2 Main Broom Motor Assembly
- 3 Reservoir Assembly
- 4 Filter Assembly
- 5 Drive Motor Assembly
- 6 Side Broom Motor Assembly
- 7 Side Broom Cylinder Assembly, Right
- 8 Dust Control Motor Assembly
- 10 Manifold Assembly

- 11 Steering Cylinder Assembly
- 12 Hopper Door Cylinder Assembly
- 13 Hopper Lift Cylinder Assembly
- 14 Pump Assembly
- 17 Elbow, 90 O-Ring
- 22 Sleeve Hydraulic Hose
- 32 Sleeve, Nylon
- 44 Decal, Oil Fill
- 45 Test Port

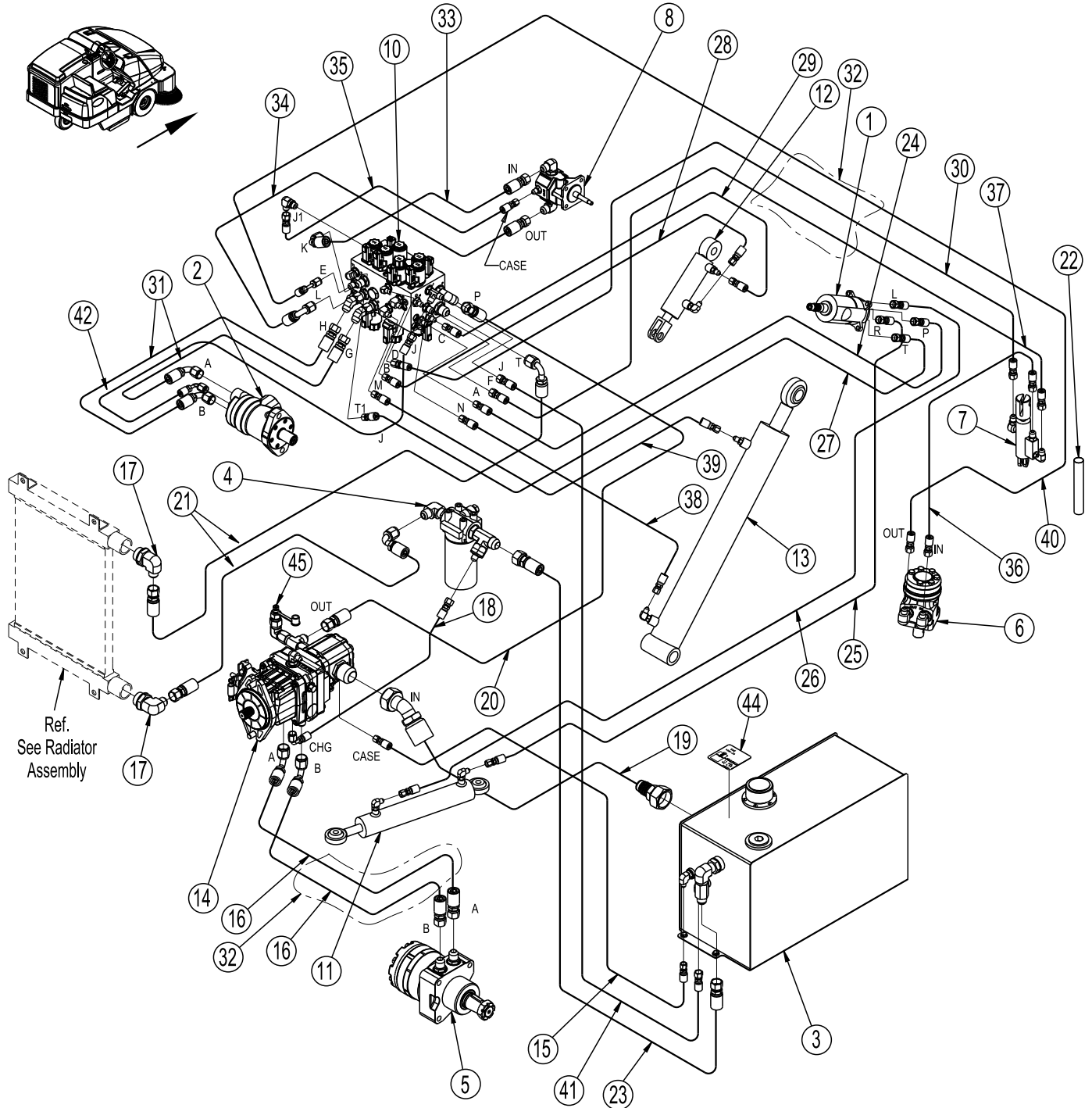

HYDRAULIC SYSTEM

Hydraulic System 4-Cylinder models

Item	Description
1	Steering Control Unit
2	Reservoir Assembly
3	Drive Motor Assembly
4	Side Broom Motor Assembly
5	Side Broom Cylinder Assembly, Right
6	Main Broom Motor Assembly
7	Dust Control Motor Assembly
8	Sleeve, 23 In. Nylon
9	Manifold Assembly
10	Steering Cylinder Assembly
11	Hopper Door Cylinder Assembly
12	Hopper Lift Cylinder Assembly
13	Pump Assembly
14	Filter Assembly
22	Elbow, 90 O-Ring
23	Sleeve Hydraulic Hose
44	Sleeve, 26 In. Nylon
45	Sleeve, 24 In. Nylon
47	Decal, Oil Fill
48	Test Port

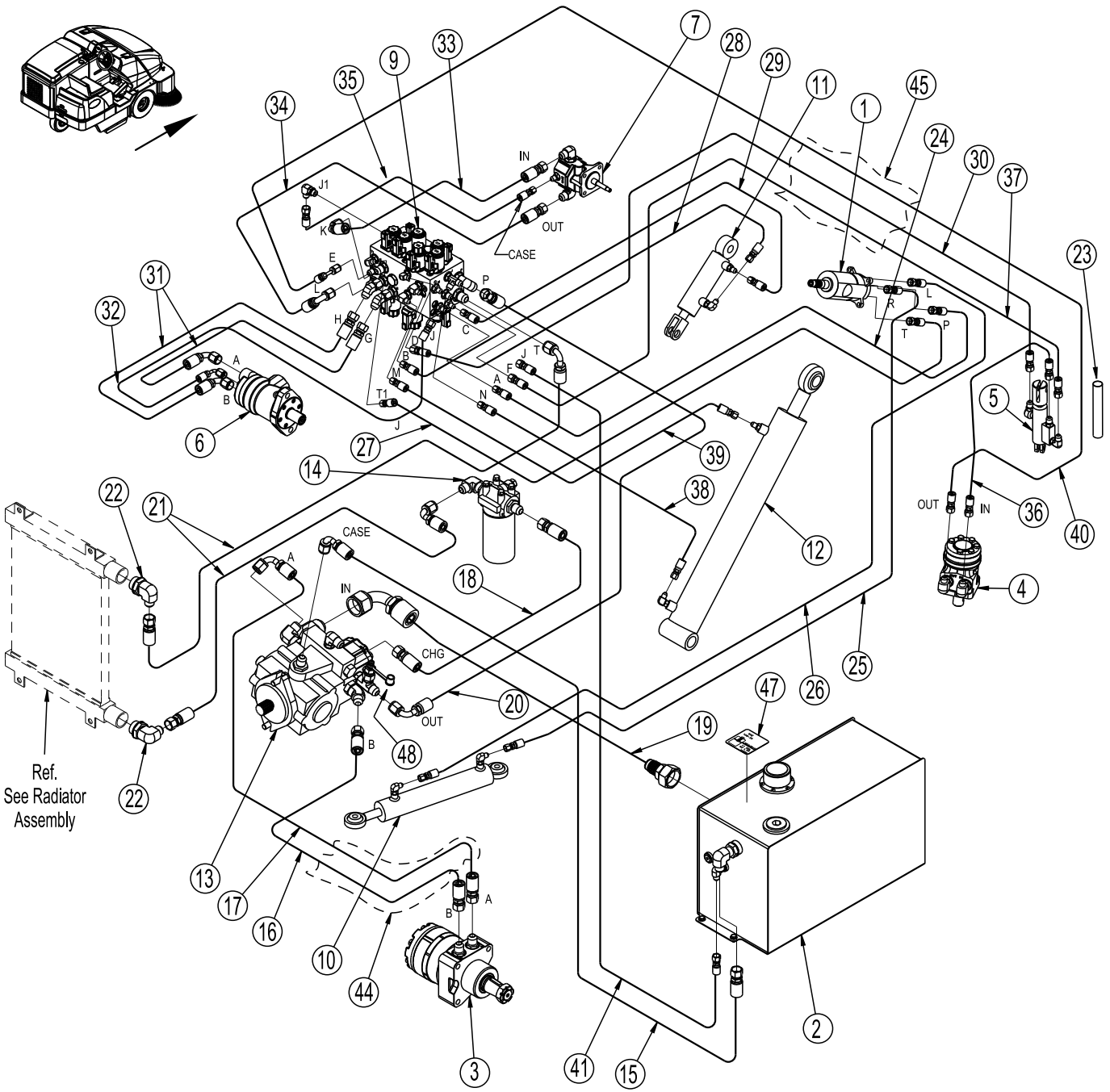

HYDRAULIC SYSTEM

Left Hand Side Broom Option

Item	Description	Item	Description
	Instruction Sheet	10	Hose, Hydraulic
1	Left Hand Side Broom Option	11	Hose, Hydraulic
2	Side Broom Cylinder Assy, Left	12	Hose, Hydraulic
3	Side Broom Motor Assembly	13	Hose, Hydraulic
4	Valve Assembly	14	Hose, Hydraulic
5	Tee, Union	15	Wire Tie (not shown)
6	Hose, Hydraulic	16	Hose Clamp, 1/4 Quadruple
7	Tee, Run O-Ring	17	Scr, Hex 1/4-20 x 1.75
8	Hose, Hydraulic	18	Wsh, Fit SAE 1/4
9	Hose, Hydraulic	19	Elbow, 90 W/Nut

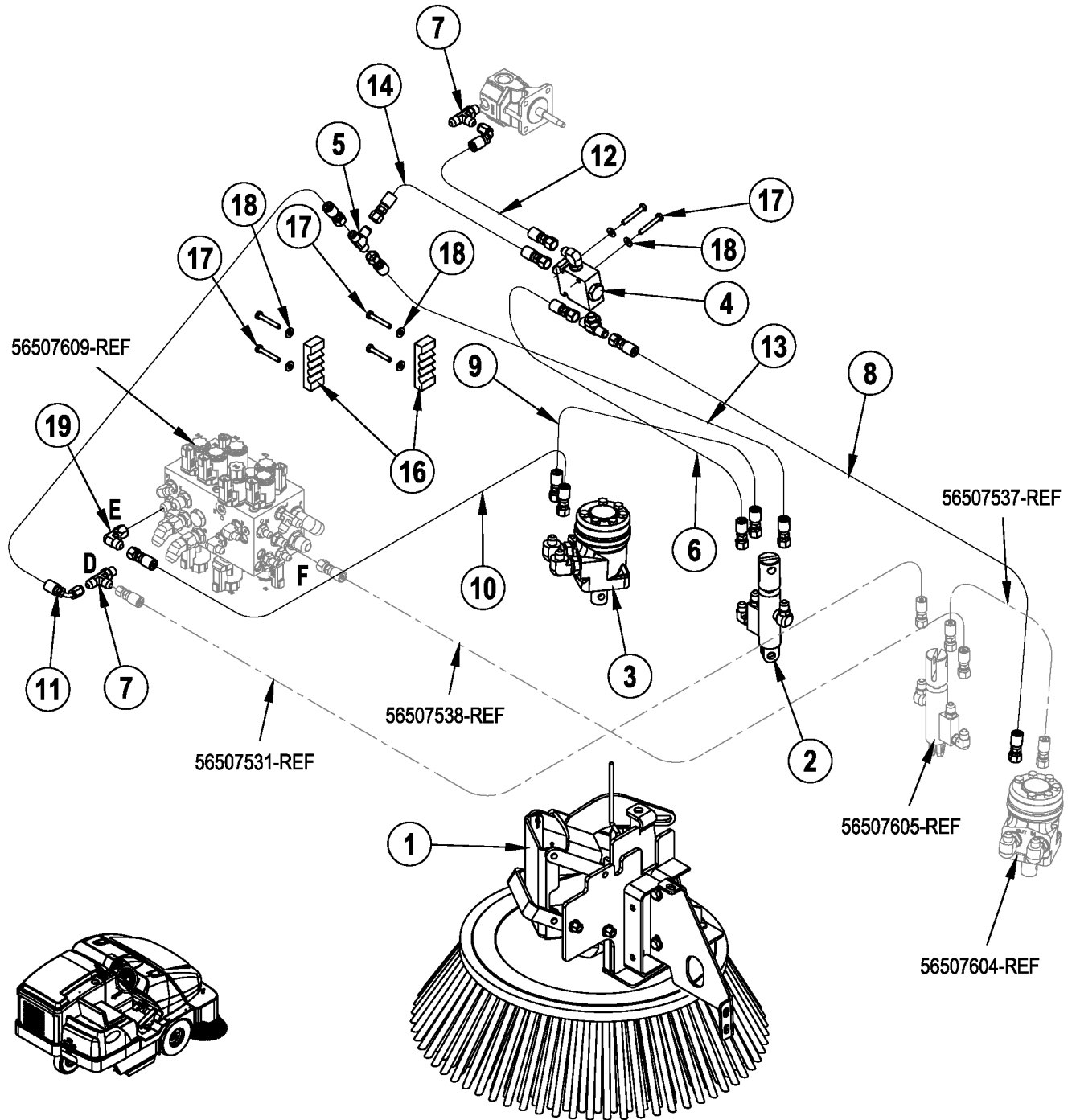

THIS PAGE IS INTENTIONALLY BLANK

HYDRAULIC SYSTEM

COMPONENT LOCATION

Item	Description
1	Drive Motor Assembly
2	Dust Control Motor Assembly
3	Filter Assembly
4	Hopper Door Cylinder
5	Hopper Lift Cylinder
6	Oil Cooler
7	Main Broom Motor Assembly
8	Manifold Assembly
9	Pump Assembly (3 cylinder pump shown)
10	Reservoir Assembly
11	Side Broom Cylinder Assembly, Right
12	Side Broom Motor Assembly
13	Steering Control Unit
14	Steering Cylinder

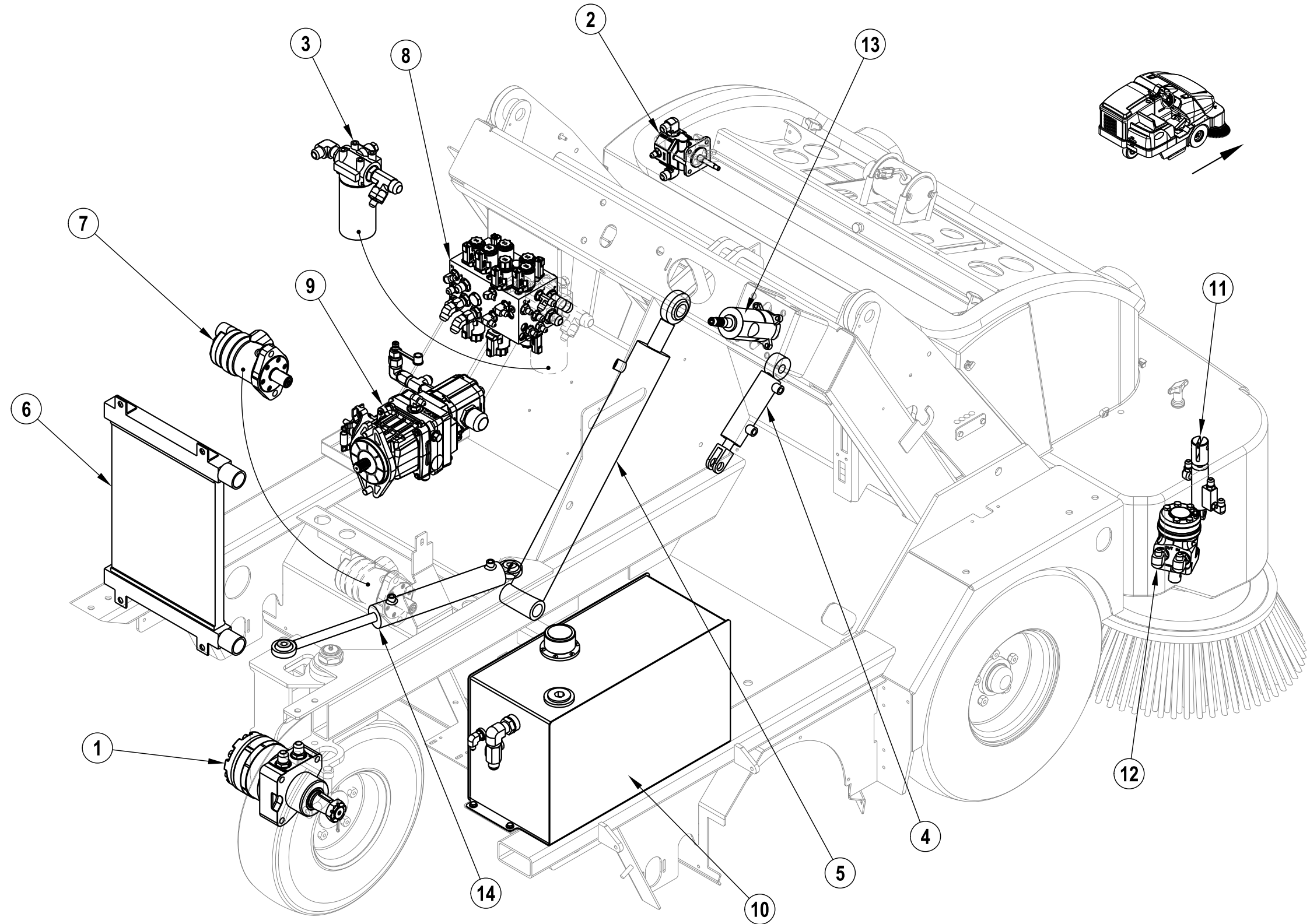

HYDRAULIC SYSTEM

HYDRAULIC SCHEMATIC 3 CYLINDER MODELS

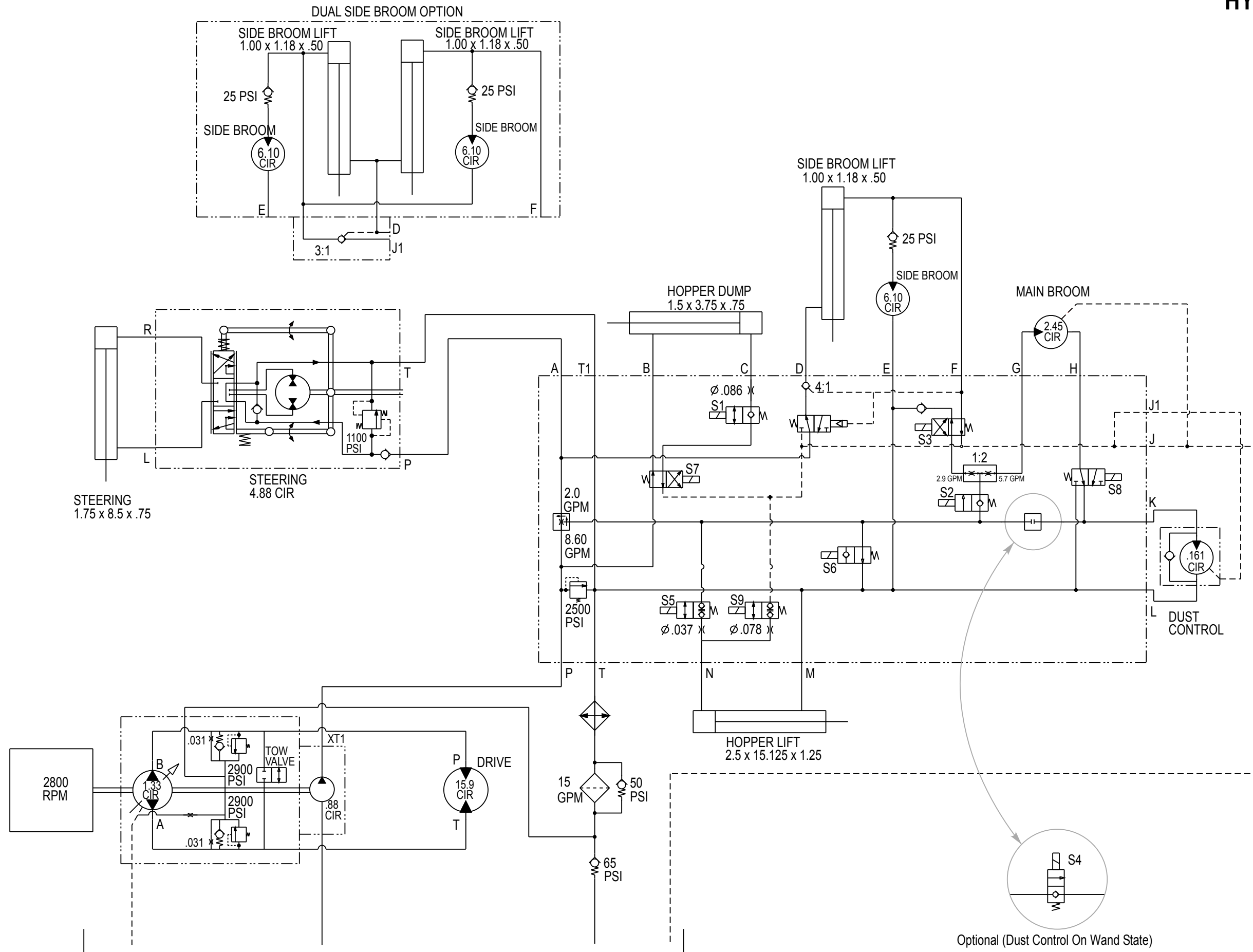

HYDRAULIC SYSTEM

HYDRAULIC SCHEMATIC 4 CYLINDER MODELS

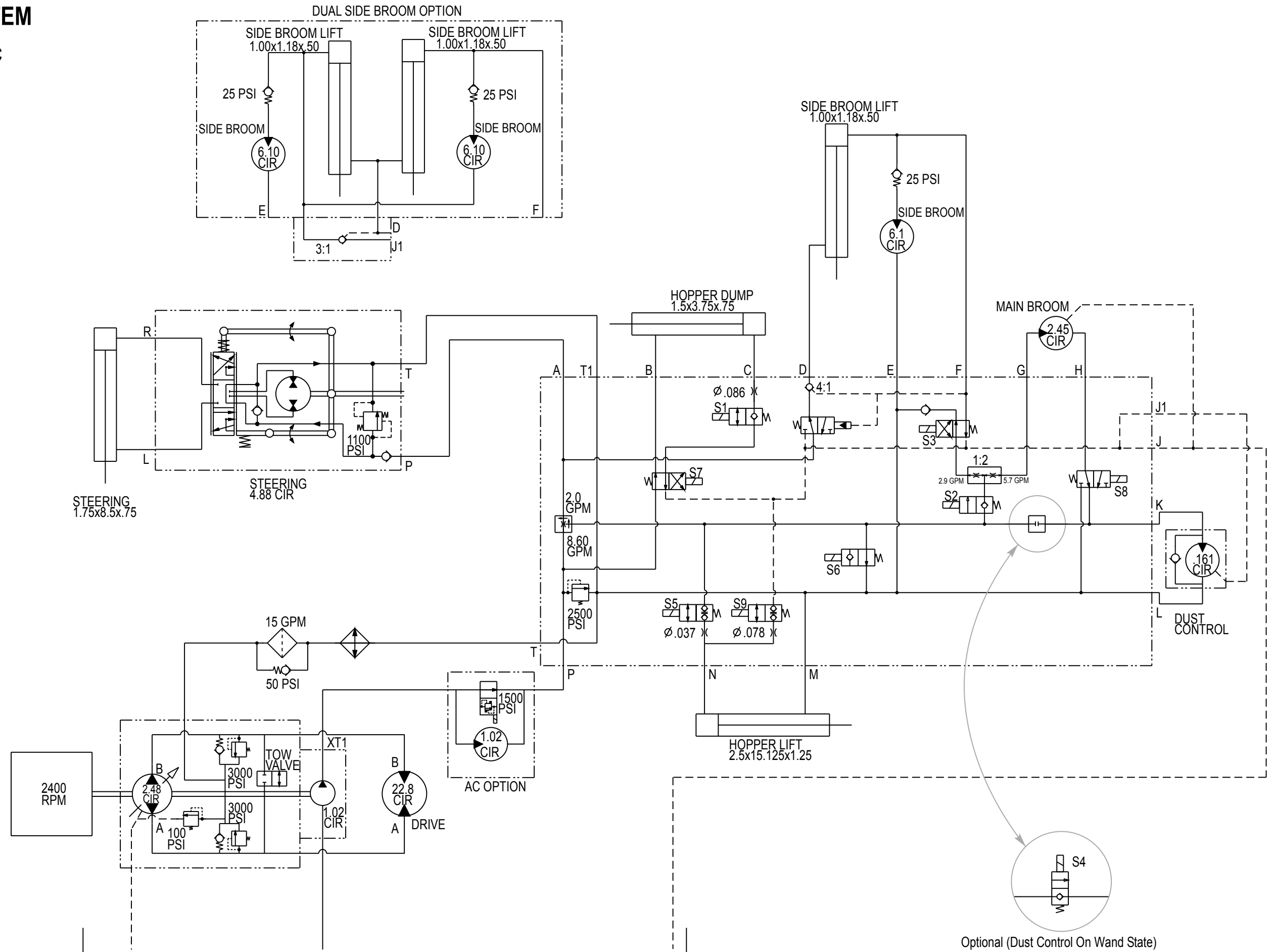

ELECTRICAL SYSTEM

COMPONENT LOCATION

Item	Description	Item	Description
A2	Control Box Assembly	LP1	Head Light, Right
BT	Battery, 12Vdc	LP2	Head Light, Left
CB1	Circuit Breaker, 70 Amp (Main)	M2	Motor, Shaker
CB2	Circuit Breaker, 20 Amp (Headlights)	P1	Hourmeter
CB3	Circuit Breaker, 15 Amp (Starter)	P2	Gauge, Fuel (not used on LPG models)
CB4	Circuit Breaker, 20 Amp (Accessories)	R2	Drive Pedal Sensor, 5K Ohm
CB5	Circuit Breaker, 10 Amp (Ignition)	R3	Sender, Fuel (not used on LPG models)
CB6	Circuit Breaker, 20 Amp (Shaker)	S1	Switch, Ignition
CB7	Circuit Breaker, 15 Amp (Turn signal) (optional)	S2	Switch, Main Broom
CB8	Circuit Breaker, 10 Amp (Misting Kit) (optional)	S3	Switch, Low LP Pressure (LPG models only)
CB9	Circuit Breaker, 40 Amp (Cab) (optional)	S4	Switch, Hopper Interlock
H1	Horn		
K1	Relay, Horn		
K2	Relay, Lights		
K3	Relay, Shaker		
K4	Relay, Neutral		

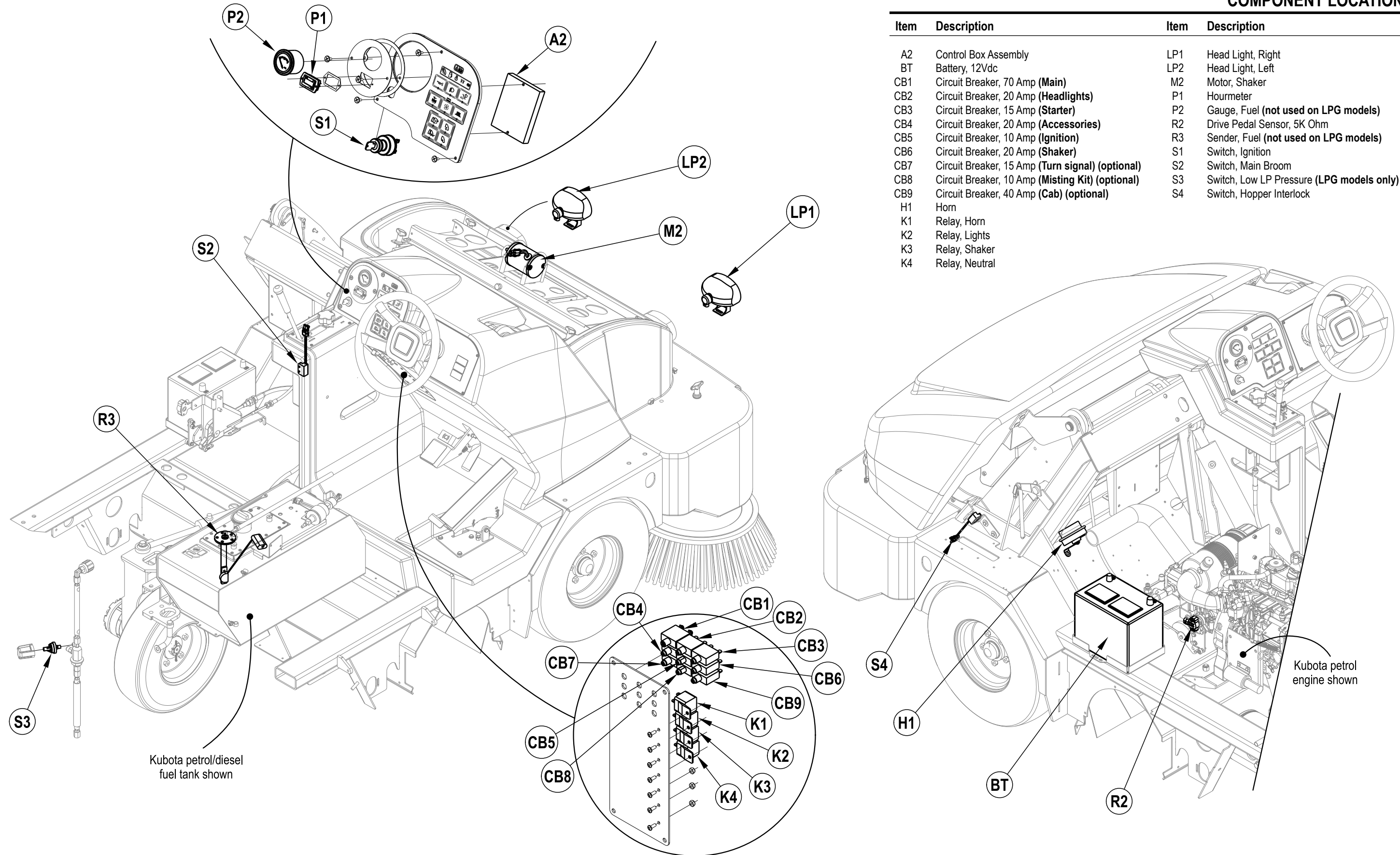

ELECTRICAL SYSTEM

WIRING DIAGRAM 1 of 3

Item Qty Description

- A3 Controller
- A5 Manifold, Fuel (GM Engine only)
- BT Battery, 12Vdc
- CB1 Circuit Breaker, 70 Amp, Main
- CB2 Circuit Breaker, 20 Amp, Headlights
- CB3 Circuit Breaker, 15 Amp, Starter
- CB4 Circuit Breaker, 20 Amp, Accessories
- CB5 Circuit Breaker, 10 Amp, Ignition
- CB6 Circuit Breaker, 20 Amp, Shaker
- CB7 Circuit Breaker, 15 Amp (signal lights option)
- CB8 Circuit Breaker, 10 Amp (misting pump option)
- CB9 Circuit Breaker, 40 Amp (for cab option)
- E13 Flasher (optional)
- F1 Fuse, 1 Amp
- H1 Horn
- K1 Relay, Horn
- K2 Relay, Lights
- K3 Relay, Shaker
- K4 Relay, Neutral
- K5 Relay, Signal Lights (optional)
- K6 Relay, Misting Pump (optional)
- K8 Relay, HVAC (optional)
- K9 Relay, Condensor Fan
- K10 Relay, Compressor
- LP1 Head Light, Right
- LP2 Head Light, Left
- LP3 Lamp, Right Front (optional)
- LP4 Lamp, Right Rear Signal (optional)
- LP5 Lamp, Right Rear Tail/Brake (optional)
- LP6 Lamp, Left Front Signal (optional)
- LP7 Lamp, Left Rear Signal (optional)
- LP8 Lamp, Left Rear Tail/Brake (optional)
- LP9 Lamp, Curb (optional)
- LP10 Lamp, Trouble (optional)
- LP11 Lamp, Rear Work (optional)
- LP12 Light, Strobe (optional)
- M2 Motor, Shaker
- M3 Pump, Fuel
- M4 Pump, Misting (optional)
- P1 Hourmeter
- P2 Gauge, Fuel (not used on LPG models)
- P3 Gauge, Combination (optional- LPG)
Gauge, Combination (optional- Petrol and Diesel)
- R1 Sender, Oil Pressure (optional)
- R3 Sender, Fuel (not used on LPG models)
- S1 Switch, Ignition
- S22 Switch, Brake
- S24 Switch (part of LP10)
- S25 Switch, Hazard (optional)
- S26 Switch, Turn Signal (optional)

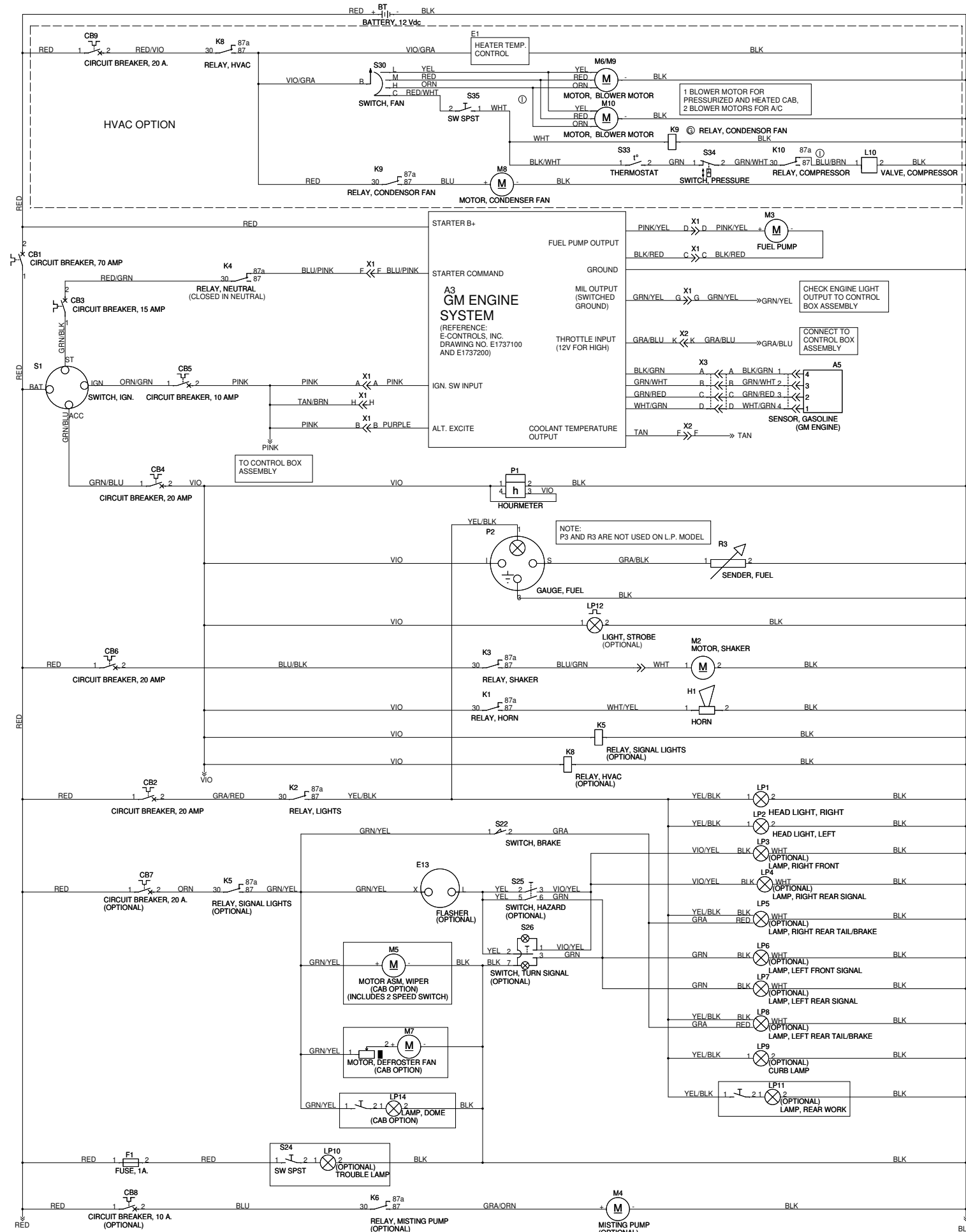

ELECTRICAL SYSTEM

WIRING DIAGRAM 2 of 3

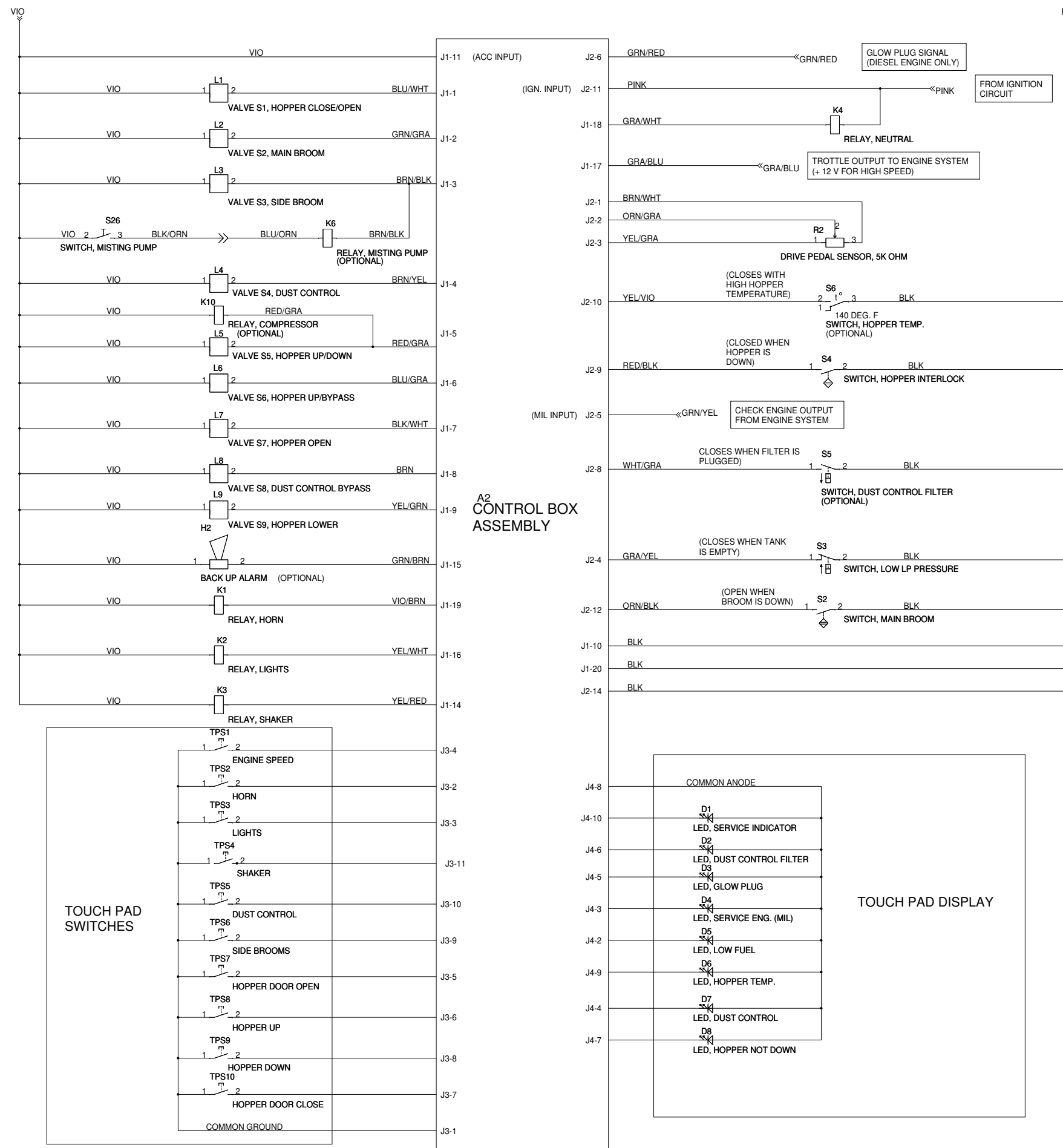

Item	Ref. No.	Qty	Description
A2			Control Box Assembly
H2			Back Up Alarm (optional)
K1			Relay, Horn
K2			Relay, Lights
K3			Relay, Shaker
K4			Relay, Neutral
K6			Relay, Misting Pump (optional)
L1			Valve S1, Hopper Close/Open
L2			Valve S2, Main Broom
L3			Valve S3, Side Broom
L4			Valve S4, Dust Control
L5			Valve S5, Hopper Up/Down
L6			Valve S6, Hopper Up/Bypass
L7			Valve S7, Hopper Open
L8			Valve S8, Dust Control Bypass
L9			Valve S9, Hopper Lower
R2			Drive Pedal Sensor, 5K Ohm
S2			Switch, Main Broom
S3			Switch, Low LP Pressure
S4			Switch, Hopper Interlock
S5			Switch, Dust Control Filter (optional)
S6			Switch, Hopper Temp. (optional)
S26			Switch, Misting Pump (optional)
TPS1			Touch Pad Switch, Engine Speed
TPS2			Touch Pad Switch, Horn
TPS3			Touch Pad Switch, Lights
TPS4			Touch Pad Switch, Shaker
TPS5			Touch Pad Switch, Dust Control
TPS6			Touch Pad Switch, Side Brooms
TPS7			Touch Pad Switch, Hopper Door Open
TPS8			Touch Pad Switch, Hopper Up
TPS9			Touch Pad Switch, Hopper Down
TPS10			Touch Pad Switch, Hopper Door Close

ELECTRICAL SYSTEM

WIRING DIAGRAM 3 of 3

Kubota 972 Engine System

Item	Ref. No.	Qty	Description
A1			Throttle Control Module
BT			Battery, 12 Vdc
CB1			Circuit Breaker, 70 Amp
CB3			Circuit Breaker, 15 Amp
CB5			Circuit Breaker, 10 Amp
D1			Diode
F2			Fuse, 30 Amp
G1			Alternator
K4			Relay, Neutral
L9			LPG Lock-Off
M1			Starter
S1			Switch, Ignition
S27			Switch, Oil Pressure
S8			Switch, Coolant Temp.
Y1			Carburetor

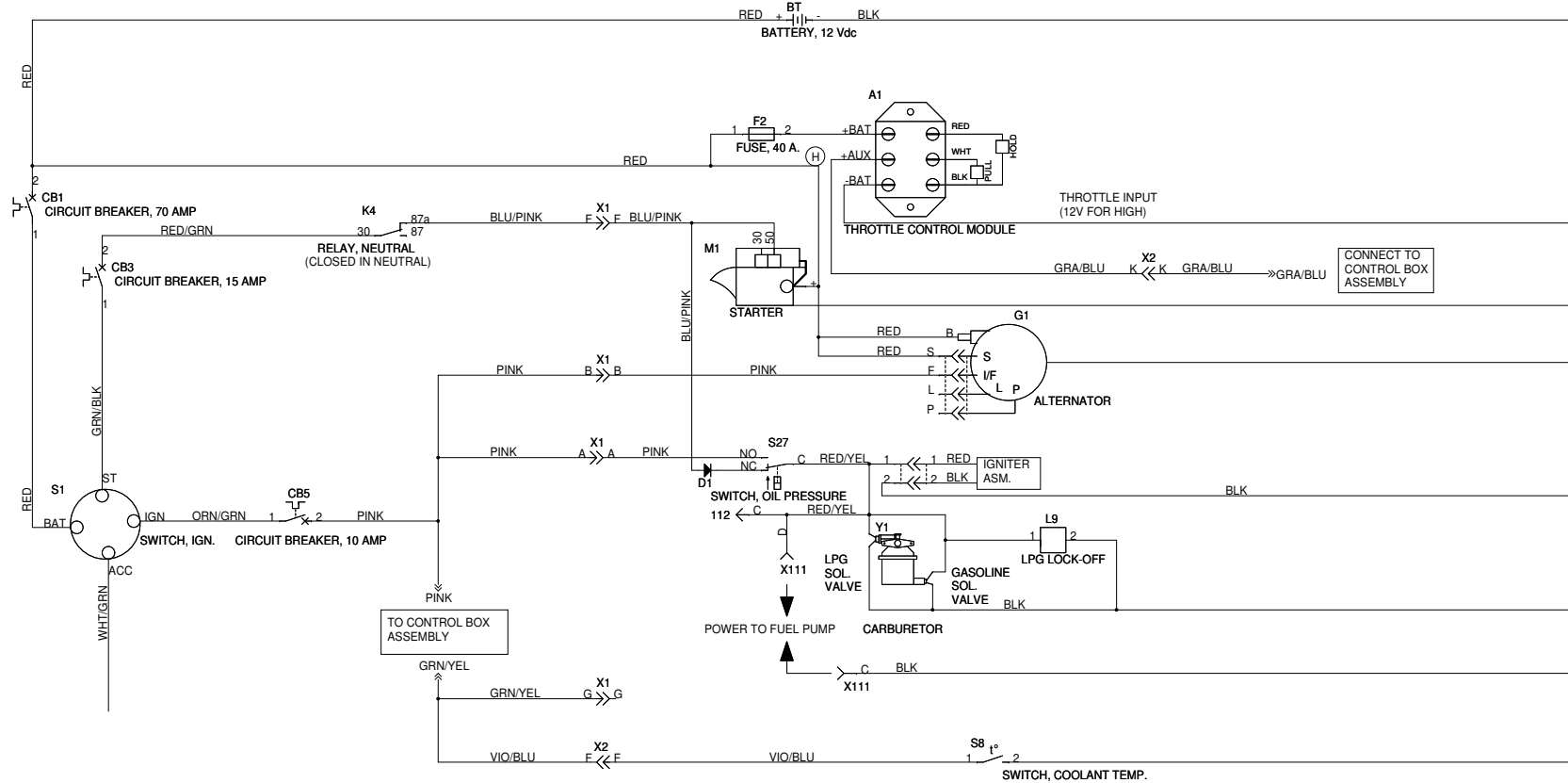

Kubota Diesel Engine System

Item	Ref. No.	Qty	Description
A4			ACPECS 3000 Governor
BT			Battery, 12 Vdc
CB1			Circuit Breaker, 70 Amp
CB3			Circuit Breaker, 15 Amp
CB4			Circuit Breaker, 20 Amp
CB5			Circuit Breaker, 10 Amp
D2			Diode
D3			Diode
E1			Glow Plug
E2			Glow Plug
E3			Glow Plug
E4			Glow Plug
G1			Alternator
K4			Relay, Neutral
K7			Relay, Acc (Diesel only)
M2			Starter
R7			Sender, Temperature
S7			Switch, Ignition
S8			Switch, Coolant Temp.
S28			Switch, Oil Pressure

KUBOTA DIESEL ENGINE SYSTEM

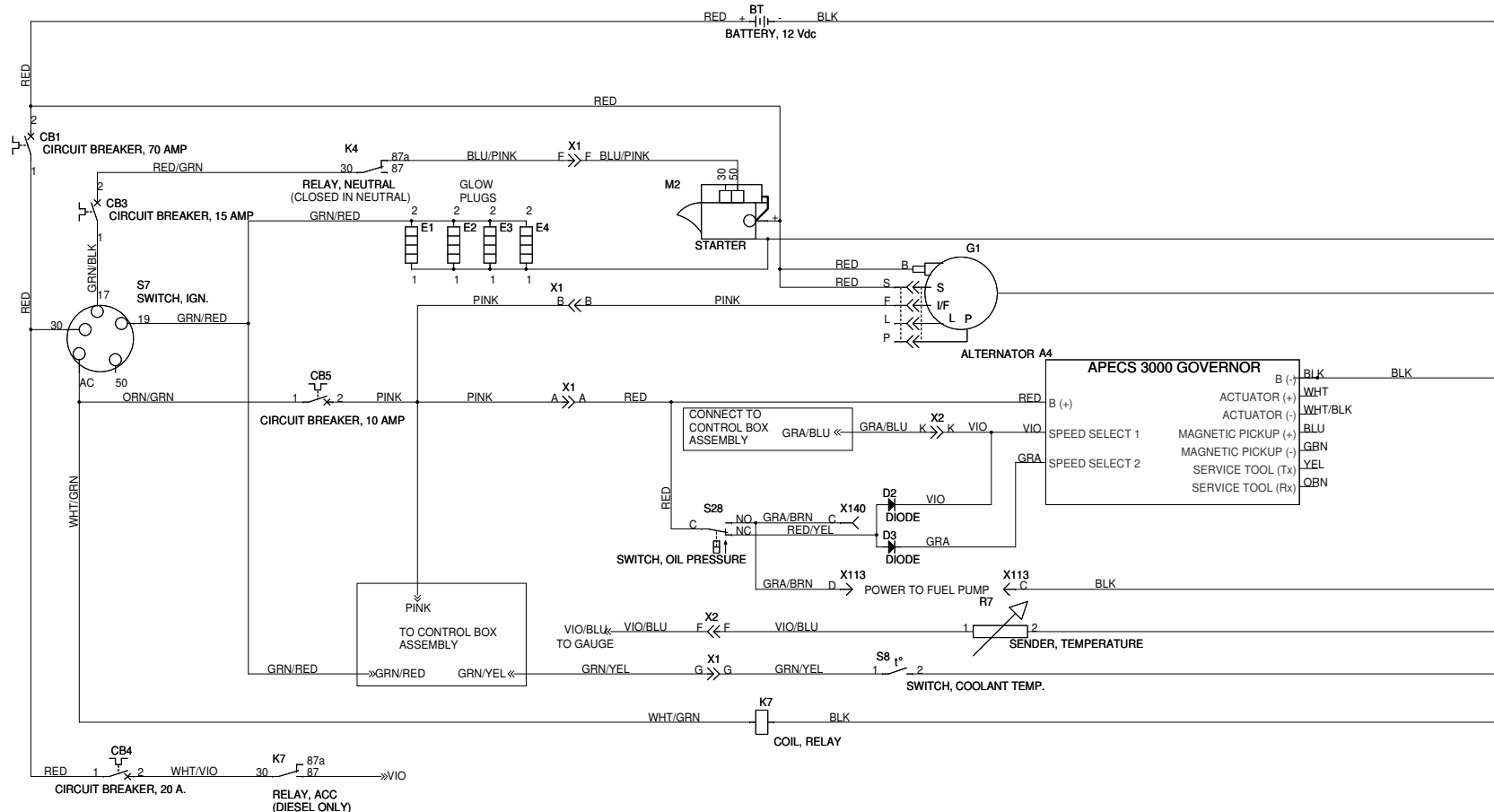

ELECTRICAL SYSTEM

WIRING SCHEMATIC 1 of 3

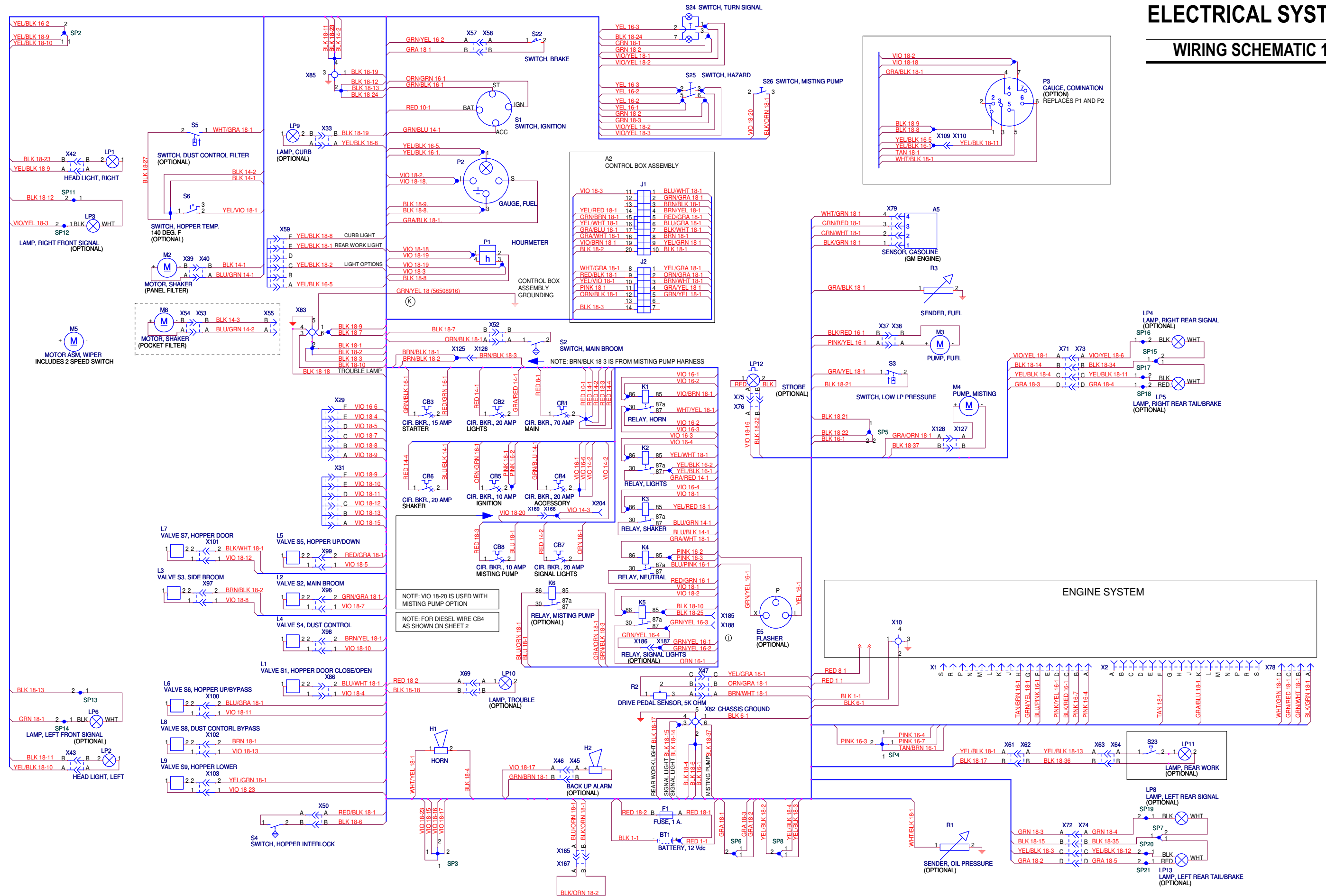

ELECTRICAL SYSTEM

WIRING SCHEMATIC 2 of 3

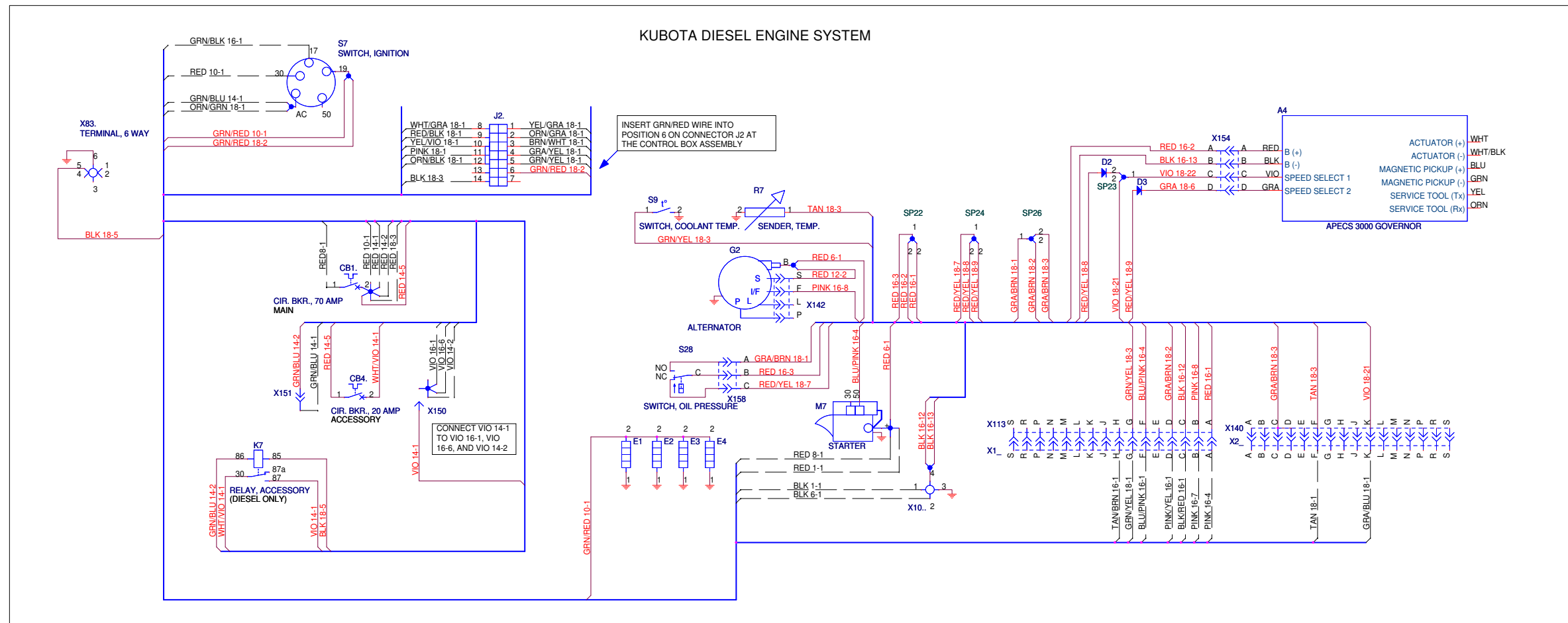
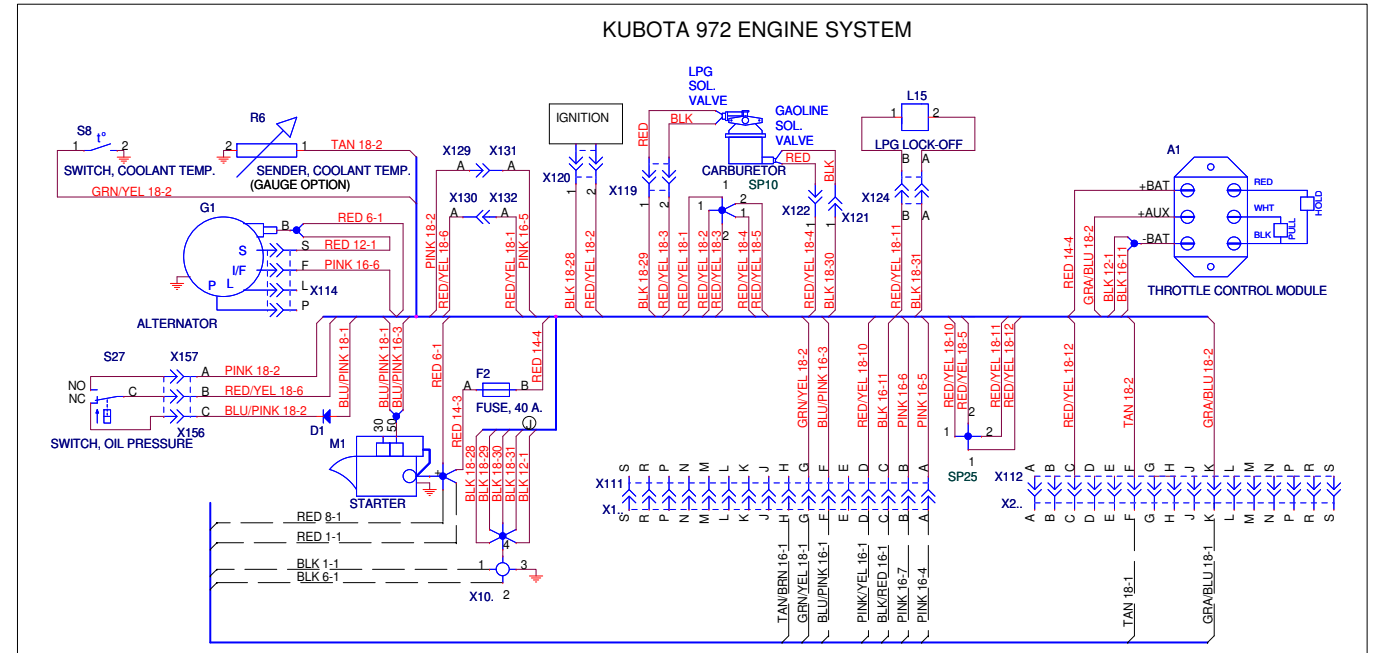
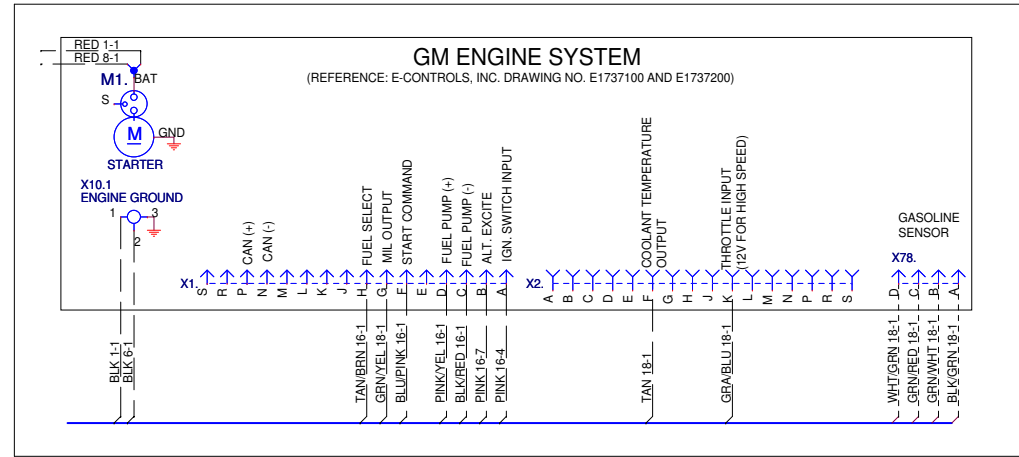

ELECTRICAL SYSTEM

WIRING SCHEMATIC 1 of 3

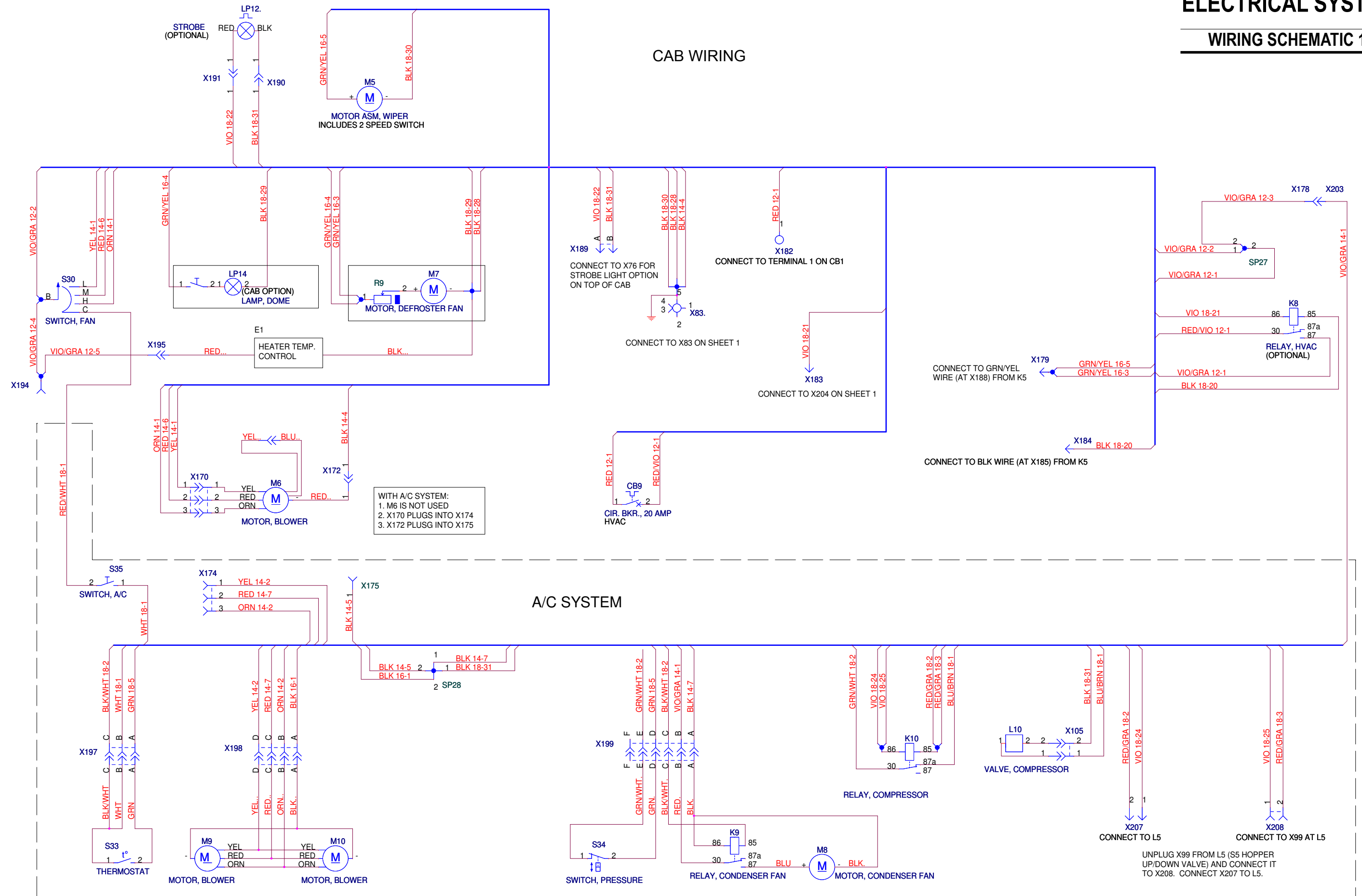

ELECTRICAL SYSTEM

ENGINE HARNESS FOR GM 1.6L GAS

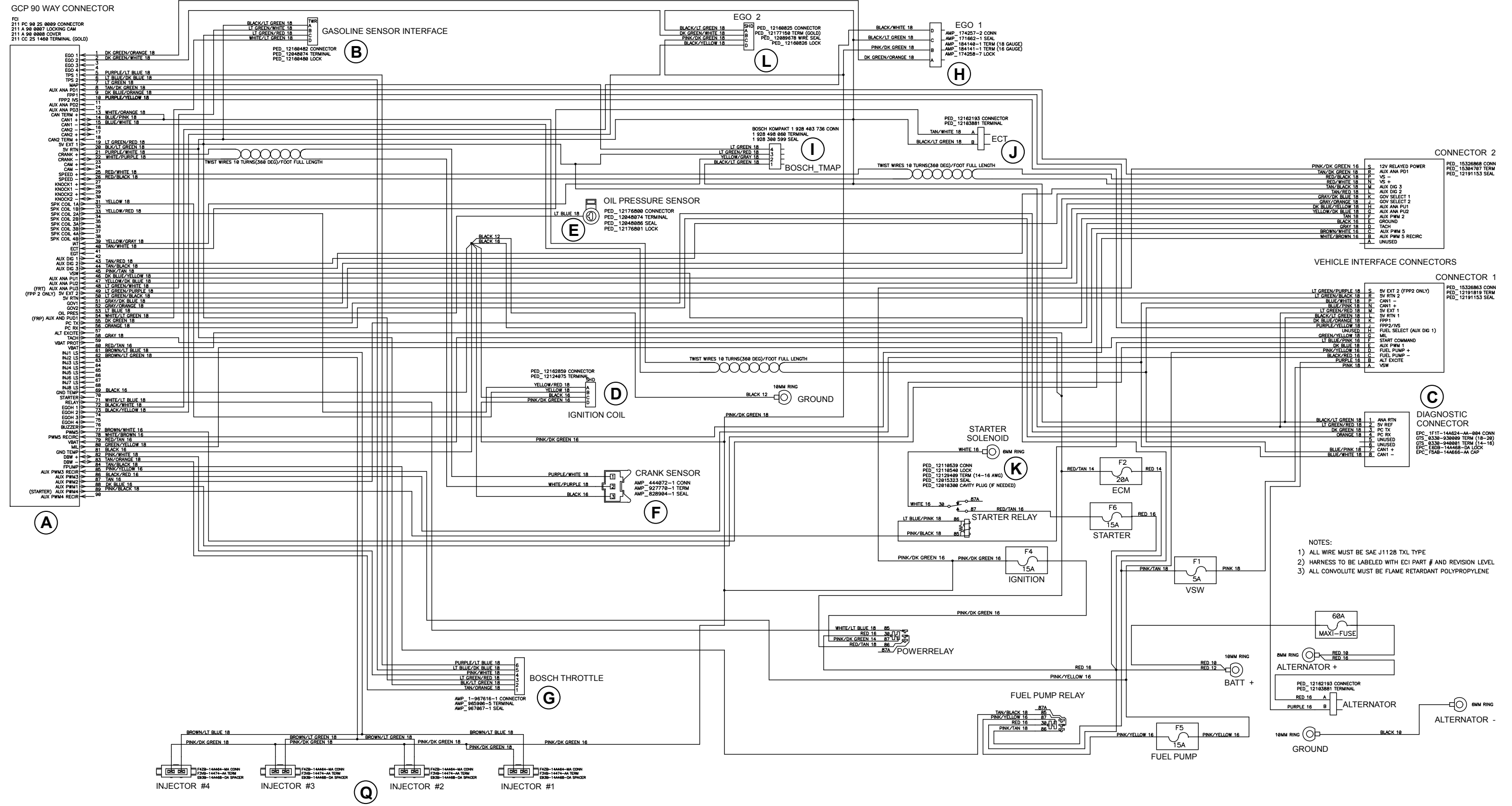

ENGINE HARNESS FOR GM 1.6L LPG

ELECTRICAL SYSTEM

GCP 90 WAY CONNECTOR

FC
211 PC 90 25 0009 CONNECTOR
211 A 90 8087 LOCKING CAM
211 A 90 8088 COVER
211 CC 25 1460 TERMINAL (GOLD)

- EGO 1 1 DK GREEN/ORANGE 18
- EGO 2 2 DK GREEN/WHITE 18
- EGO 3 3 PURPLE/LT BLUE 18
- EGO 4 4 LT BLUE/DK BLUE 18
- TPS 1 5 TAN/DK GREEN 18
- TPS 2 6 DK BLUE/ORANGE 18
- MWP 7 LT GREEN 18
- AUX ANA PD1 8 TAN/DK GREEN 18
- PPH1 9 PURPLE/YELLOW 18
- FPF2 MS 10
- AUX ANA PD2 11
- AUX ANA PD3 12
- CAN1 + 13 WHITE/ORANGE 18
- CAN1 - 14 BLUE/PINK 18
- CAN2 + 15 BLUE/WHITE 18
- CAN2 - 16
- CANZ + 17
- CANZ - 18
- SV EXT 1 19 LT GREEN/RED 18
- SV RTN 20 BLACK/LT GREEN 18
- CRANK + 21 PURPLE/WHITE 18
- CRANK - 22 WHITE/PURPLE 18
- CAM + 23
- CAM - 24 RED/WHITE 18
- SPEED + 25 RED/BLACK 18
- VS 26
- KNOCK1 + 27
- KNOCK1 - 28
- KNOCK2 + 29
- KNOCK2 - 30
- SPK COIL 1A 31 YELLOW 18
- SPK COIL 1B 32
- SPK COIL 2A 33 YELLOW/RED 18
- SPK COIL 2B 34
- SPK COIL 3A 35
- SPK COIL 3B 36
- SPK COIL 4A 37
- SPK COIL 4B 38
- WT 39
- ECI 40
- ECI 41
- ECI 42
- AUX DIG 1 43 TAN/RED 18
- AUX DIG 2 44 TAN/BLACK 18
- AUX DIG 3 45 PINK/TAN 18
- NSW 46
- AUX ANA PU1 47 DK BLUE/YELLOW 18
- AUX ANA PU2 48
- (FR) AUX ANA PU3 49 LT GREEN/PURPLE 18
- (FR) AUX ANA PU4 50
- (FR) AUX ANA PU5 51
- (FR) AUX ANA PU6 52
- (FR) AUX ANA PU7 53
- (FR) AUX ANA PU8 54
- (FR) AUX ANA PU9 55
- (FR) AUX ANA PU10 56
- (FR) AUX ANA PU11 57
- (FR) AUX ANA PU12 58
- (FR) AUX ANA PU13 59
- (FR) AUX ANA PU14 60
- (FR) AUX ANA PU15 61
- (FR) AUX ANA PU16 62
- (FR) AUX ANA PU17 63
- (FR) AUX ANA PU18 64
- (FR) AUX ANA PU19 65
- (FR) AUX ANA PU20 66
- (FR) AUX ANA PU21 67
- (FR) AUX ANA PU22 68
- (FR) AUX ANA PU23 69
- (FR) AUX ANA PU24 70
- (FR) AUX ANA PU25 71
- (FR) AUX ANA PU26 72
- (FR) AUX ANA PU27 73
- (FR) AUX ANA PU28 74
- (FR) AUX ANA PU29 75
- (FR) AUX ANA PU30 76
- (FR) AUX ANA PU31 77
- (FR) AUX ANA PU32 78
- (FR) AUX ANA PU33 79
- (FR) AUX ANA PU34 80
- (FR) AUX ANA PU35 81
- (FR) AUX ANA PU36 82
- (FR) AUX ANA PU37 83
- (FR) AUX ANA PU38 84
- (FR) AUX ANA PU39 85
- (FR) AUX ANA PU40 86
- (FR) AUX ANA PU41 87
- (FR) AUX ANA PU42 88
- (FR) AUX ANA PU43 89
- (FR) AUX ANA PU44 90
- (FR) AUX ANA PU45 91
- (FR) AUX ANA PU46 92
- (FR) AUX ANA PU47 93
- (FR) AUX ANA PU48 94
- (FR) AUX ANA PU49 95
- (FR) AUX ANA PU50 96
- (FR) AUX ANA PU51 97
- (FR) AUX ANA PU52 98
- (FR) AUX ANA PU53 99
- (FR) AUX ANA PU54 100

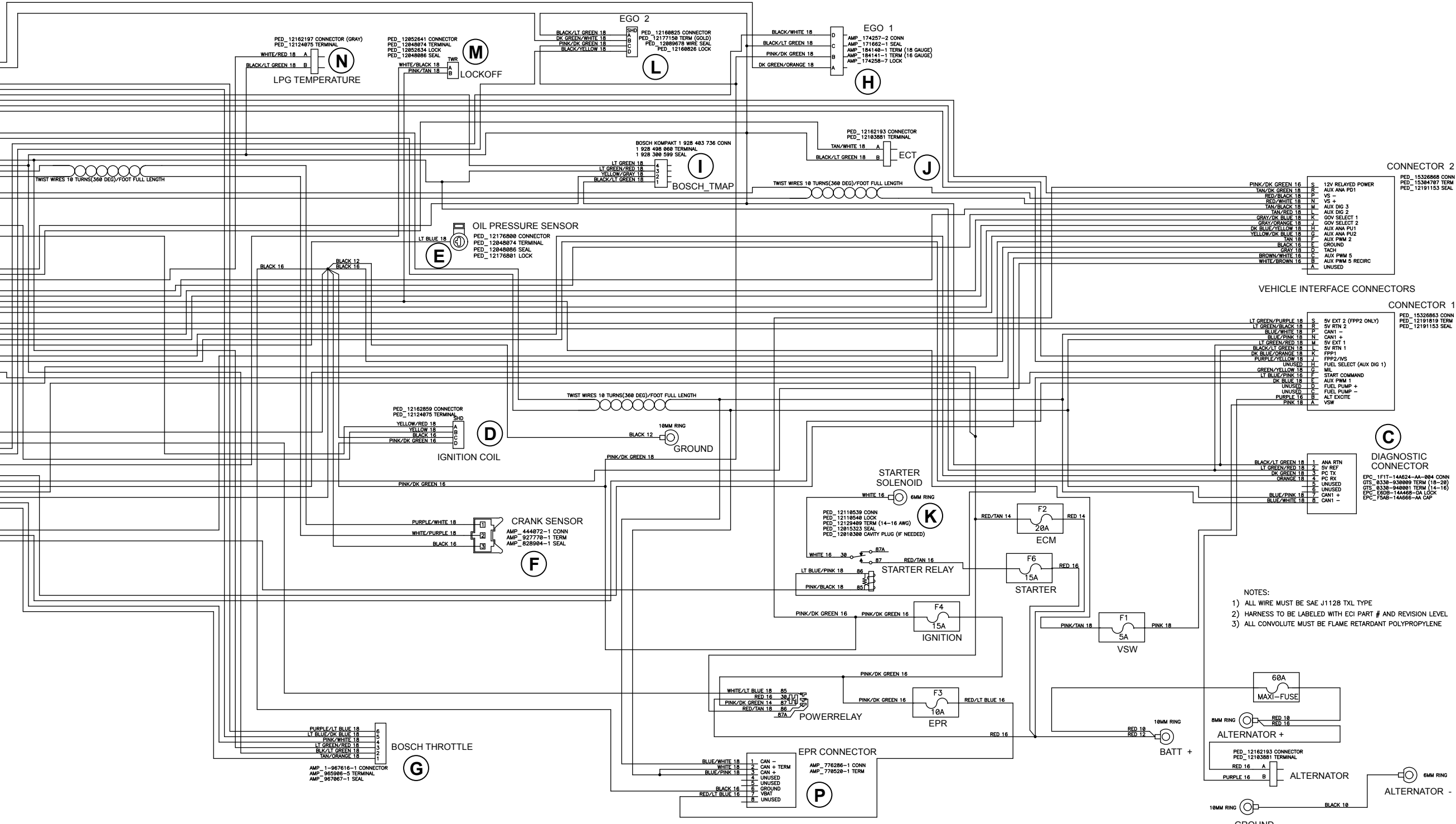

- NOTES:
- 1) ALL WIRE MUST BE SAE J1128 TXL TYPE
 - 2) HARNESS TO BE LABELED WITH ECI PART # AND REVISION LEVEL
 - 3) ALL CONVOLUTE MUST BE FLAME RETARDANT POLYPROPYLENE

ELECTRICAL SYSTEM

Wiring Harness Item	Wiring Harness Component Description
A	ECM Wiring Connector (90 Pins)
B	Gasoline/Petrol Fuel Sensor Interface Connector (fuel pressure regulation and temperature sensor manifold assembly)
C	Engine Diagnostic Communication Port (8 Pin) (MIL shorting location)
D	Ignition Coil Pack Wiring Connector
E	Engine Oil Pressure Switch
F	Crankshaft Position Sensor Connector
G	Throttle Fly Actuator Motor Connector (Bosch)
H	EGO #1 Sensor Wiring Connector
I	Combined TMAP Engine Air Temperature and MAP Sensor Wiring Connector
J	Engine Coolant Temperature (ECT) Sensor Connector
K	Engine Starter Solenoid Wire Connector
L	EGO #2 Sensor Wiring Connector
M	LPG Fuel Lockoff Wiring Connector
N	LPG Temp Sensor Wiring Connector
P	EPR Connector (LPG) Fuel Regulator
Q	Gasoline Fuel Injectors

EGO 1	1	DK GREEN/ORANGE 18
EGO 2	2	DK GREEN/ORANGE 18
EGO 3	3	
EGO 4	4	
TPS 1	5	PURPLE/LT BLUE 18
TPS 2	6	LT BLUE/DK BLUE 18
MAP	7	LT GREEN 18
AUX ANA PD1	8	TAN/DK GREEN 18
FPP1	9	DK BLUE/ORANGE 18
FPP2 IVS	10	PURPLE/YELLOW 18
AUX ANA PD2	11	
AUX ANA PD3	12	
CAN TERM +	13	WHITE/ORANGE 18
CAN1 +	14	BLUE/PINK 18
CAN1 -	15	BLUE/WHITE 18
CAN2 -	16	
CAN2 +	17	
CAN2 TERM +	18	
5V EXT 1	19	LT GREEN/RED 18
5V RTN	20	BLK/LT GREEN 18
CRANK +	21	PURPLE/WHITE 18
CRANK -	22	WHITE/PURPLE 18
CAM +	23	
CAM -	24	
SPEED +	25	RED/WHITE 18
SPEED -	26	RED/BLACK 18
KNOCK1 +	27	
KNOCK1 -	28	
KNOCK2 +	29	
KNOCK2 -	30	
SPK COIL 1A	31	YELLOW 18
SPK COIL 1B	32	
SPK COIL 2A	33	YELLOW/RED 18
SPK COIL 2B	34	
SPK COIL 3A	35	
SPK COIL 3B	36	
SPK COIL 4A	37	
SPK COIL 4B	38	
IAT	39	YELLOW/GRAY 18
ECT	40	TAN/WHITE 18
EGT	41	
AUX DIG 1	42	
AUX DIG 2	43	TAN/RED 18
AUX DIG 3	44	TAN/BLACK 18
VSW	45	PINK/TAN 18
AUX ANA PU1	46	DK BLUE/YELLOW 18
AUX ANA PU2	47	YELLOW/DK BLUE 18
(FRT) AUX ANA PU3	48	LT GREEN/WHITE 18
(FPP 2 ONLY) 5V EXT 2	49	LT GREEN/PURPLE 18
5V RTN	50	LT GREEN/BLACK 18
GOV1	51	GRAY/DK BLUE 18
GOV2	52	GRAY/ORANGE 18
OIL PRES	53	LT BLUE 18
(FRP) AUX AND PUD1	54	WHITE/LT GREEN 18
PC TX	55	DK GREEN 18
PC RX	56	ORANGE 18
ALT EXCITE	57	
TACH	58	GRAY 18
VBAT PROT	59	
VBAT	60	RED/TAN 16
INJ1 LS	61	BROWN/LT BLUE 18
INJ2 LS	62	BROWN/LT GREEN 18
INJ3 LS	63	
INJ4 LS	64	
INJ5 LS	65	
INJ6 LS	66	
INJ7 LS	67	
INJ8 LS	68	
GND TEMP	69	BLACK 16
STARTER RELAY	70	
EGOH 1	71	WHITE/LT BLUE 18
EGOH 2	72	BLACK/WHITE 18
EGOH 3	73	BLACK/YELLOW 18
EGOH 4	74	
BUZZER	75	
PWM5	76	
PWM5 RECIRC	77	BROWN/WHITE 16
VBAT	78	WHITE/BROWN 16
MIL	79	RED/TAN 16
GND TEMP	80	GREEN/YELLOW 18
DBW +	81	BLACK 16
DBW -	82	PINK/WHITE 18
FPUMP	83	TAN/ORANGE 18
AUX PWM3 RECIR	84	TAN/BLACK 18
AUX PWM3	85	PINK/YELLOW 16
AUX PWM2	86	BLACK/RED 16
AUX PWM1	87	TAN 16
(STARTER) AUX PWM4	88	DK BLUE 16
AUX PWM4 RECIR	89	PINK/BLACK 18
	90	

Definition of Terms for Computerized Engine Controllers

- ANA-RTN:
- ECM: Engine Control Module
- EGO: Exhaust Gas Oxygen Sensor (O2)
- EPR: Electronic Pressure Regulator
- IAT: Intake Manifold Air Temperature
- MAP: Intake Manifold Absolute Pressure
- MIL: Malfunction Indicator Light
- VSW: Switched Battery Voltage
- VBAT: Battery Voltage

ECM Harness Connectors

CONNECTOR 2	
PINK/DK GREEN 16	S 12V RELAYED POWER
TAN/DK GREEN 18	R AUX ANA PD1
RED/BLACK 18	P VS -
RED/WHITE 18	N VS +
TAN/BLACK 18	M AUX DIG 3
TAN/RED 18	L AUX DIG 2
GRAY/DK BLUE 18	K GOV SELECT 1
GRAY/ORANGE 18	J GOV SELECT 2
DK BLUE/YELLOW 18	H AUX ANA PU1
YELLOW/DK BLUE 18	G AUX ANA PU2
TAN 18	F AUX PWM 2
BLACK 16	E GROUND
GRAY 18	D TACH
BROWN/WHITE 16	C AUX PWM 5
WHITE/BROWN 16	B AUX PWM 5 RECIRC
	A UNUSED

CONNECTOR 1	
LT GREEN/PURPLE 18	S 5V EXT 2 (FPP2 ONLY)
LT GREEN/BLACK 18	R 5V RTN 2
BLUE/WHITE 18	P CAN1 -
BLUE/PINK 18	N CAN1 +
LT GREEN/RED 18	M 5V EXT 1
BLACK/LT GREEN 18	L 5V RTN 1
DK BLUE/ORANGE 18	K FPP1
PURPLE/YELLOW 18	J FPP2/IVS
UNUSED	H FUEL SELECT (AUX DIG 1)
GREEN/YELLOW 18	G MIL
LT BLUE/PINK 16	F START COMMAND
DK BLUE 18	E AUX PWM 1
PINK/YELLOW 16	D FUEL PUMP +
BLACK/RED 16	C FUEL PUMP -
PURPLE 16	B ALT EXCITE
PINK 18	A VSW

GASOLINE SENSOR INTERFACE (GASOLINE MODELS ONLY)	
BLACK/LT GREEN 18	A
LT GREEN/WHITE 18	B
LT GREEN/RED 18	C
WHITE/LT GREEN 18	D

DIAGNOSTIC CONNECTOR	
BLACK/LT GREEN 18	1 ANA RTN
LT GREEN/RED 18	2 5V REF
DK GREEN 18	3 PC TX
ORANGE 18	4 PC RX
	5 UNUSED
	6 UNUSED
BLUE/PINK 18	7 CAN1 +
BLUE/WHITE 18	8 CAN1 -

ECM Detail

Machine Harness Connectors

X2	
	S
	R
	P
	N
	M
	L
THROTTLE INPUT (12V FOR HIGH SPEED)	K GRA/BLU 18-1
	H
	G
COOLANT TEMP. OUTPUT	F TAN 18-1
	E
	D
	C
	B
	A

X1	
	S
	R
	P
CAN1 (-) CAN1 (+)	N
	M
	L
	K
	J
FUEL SELECT	H TAN/BRN 16-1
MIL OUTPUT	G GRN/YEL 18-1
START COMMAND	F BLU/PINK 16-1
	E
FUEL PUMP (+)	D PINK/YEL 16-1
FUEL PUMP (-)	C BLK/RED 16-1
ALT. EXCITE	B PINK 16-7
IGN. SWITCH INPUT	A PINK 16-4

X78	
	D WHT/GRN 18-1
	C GRN/RED 18-1
	B GRN/WHT 18-1
	A BLK/GRN 18-1

ELECTRICAL SYSTEM

FIGURE 1

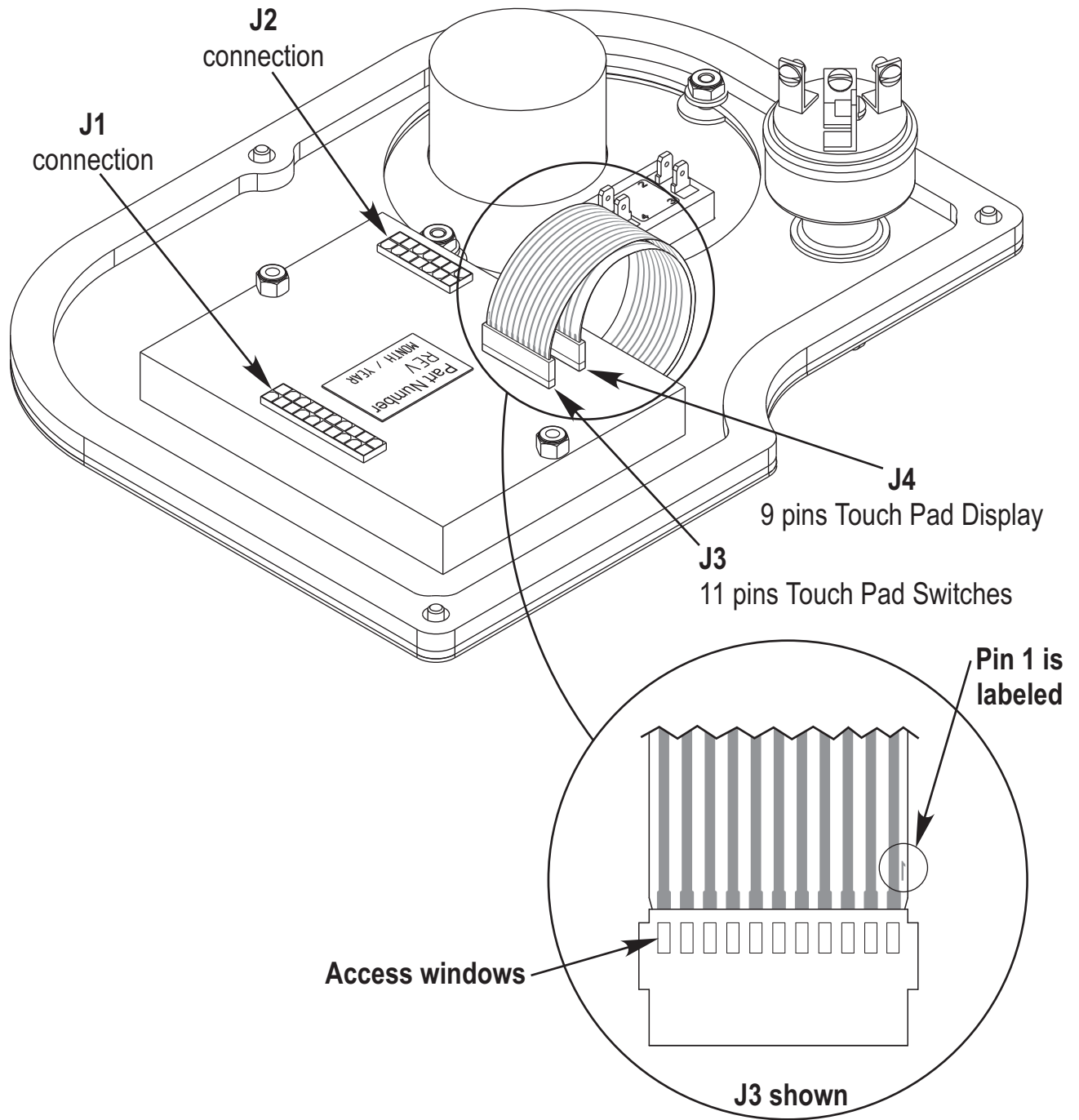

ELECTRICAL SYSTEM

PROGRAMMABLE CONTROL OPTIONS

Foot Pedal Neutral Position and Dead-band Adjustment:

FACTORY DEFAULT: 2

RANGE: 1 - 3

The various scrub and sweep functions on the Falcon are activated when the foot pedal is moved from the neutral position. The engine neutral-start relay is also activated when the foot pedal is moved from the neutral position. These functions are triggered via a position sensor mounted on the hydrostat. Whenever adjustments are made to the hydrostat unit, the neutral position will need to be programmed. Also, the neutral dead-band (sensitivity) can be adjusted if necessary. To set the neutral position and adjust the neutral dead-band perform the following steps:

- 1) Turn the **main power key switch** to the **off** position.
- 2) Depress the foot pedal to the full reverse position.
- 3) Allow the foot pedal to slowly return to the neutral position and do not move the pedal during the remainder of this procedure.
- 4) Press and hold the **engine speed switch**.
- 5) While holding the engine speed switch turn the **main power key switch** to the **on** position.
- 6) Continue to hold the engine speed switch until all indicators turn off (approximately two seconds).
- 7) Release the engine speed switch.
- 8) The service indicator will now be lit. Pressing and releasing the **engine speed switch** will increase the deadband to the middle range. Pressing and releasing the **engine speed switch** again will increase the deadband to the maximum range. The next press will return the deadband to the minimum range. The service indicator will be on steady if the minimum range is selected, it will flash at a slow rate if the middle range is selected, and it will flash at a fast rate if the maximum range is selected.
- 9) To save the new setting, turn the **main power key switch** to the **off** position.
- 10) The new setting will be saved and will remain in effect until it is changed again.

Recall Of Stored Fault Codes:

Whenever an electrical system fault is detected by the main control unit, one or more fault codes are displayed and stored by the control unit. If it is desired, the fault code (if any) from the previous operation of the machine can be recalled for troubleshooting purposes. To recall the last stored fault codes perform the following steps:

- 1) Turn the **main power key switch** to the **off** position.
- 2) Press and hold the **horn switch**.
- 3) While holding the horn switch, turn the **main power key switch** to the **on** position.
- 4) Continue to hold the horn switch until all indicators turn off (approximately two seconds).
- 5) Release the horn switch.
- 6) If there were previously no error codes stored, the service indicator will be lit continuously. If error codes were stored, the service indicator will now flash the stored code(s).
- 7) To clear the stored codes press and release the **horn switch**. The service indicator will light continuously.
- 8) To exit the error code recall mode, turn the **main power key switch** to the **off** position.

ELECTRICAL SYSTEM PROGRAMMABLE CONTROL OPTIONS

Automatic Shaker Operation:

FACTORY DEFAULT: ON

RANGE: ON, OFF

The dust control filter shaker can be programmed to automatically activate each time the main broom is turned off to automatically clean the filter. To turn this feature on or off perform the following steps:

- 1) Turn the **main power key switch** to the **off** position.
- 2) Press and hold the **shaker switch**.
- 3) While holding the shaker switch turn the **main power key switch** to the **on** position.
- 4) Continue to hold the shaker switch until all indicators turn off (approximately two seconds).
- 5) Release the shaker switch.
- 6) Pressing and releasing the **shaker switch** will alternately turn the automatic shaker feature on or off. If the feature is on the indicator on the shaker switch will be lit. If the feature is off the indicator will be off.
- 7) To save the new setting, turn the **main power key switch** to the **off** position.

The new setting will be saved and will remain in effect until it is changed again.



**Nilfisk
Advance**

setting standards

Nilfisk-Advance, Inc.
14600 21st Avenue North
Plymouth, MN 55447-3408
www.nilfisk-advance.com
Phone: 800-989-2235
Fax: 800-989-6566
©2009 Nilfisk-Advance, Inc.