

AquaClean™ 16ST, 16XP, 18FLX, 18ST

AX 410

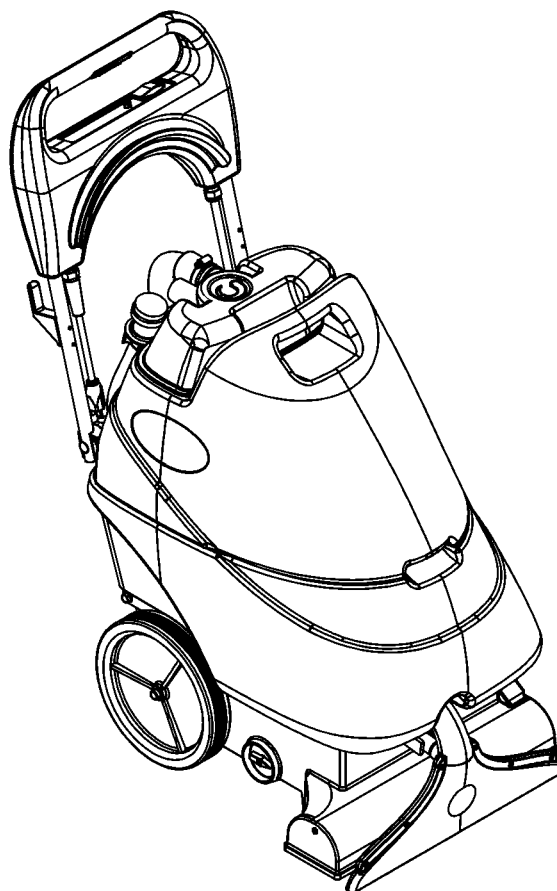

PARTS LIST

**Advance MODELS 56265003(16ST),
56265000(16XP), 56265001(18FLX), 56265008(18ST)
Nilfisk MODELS 56265002(230V), 56265007(100V J)**



**Nilfisk
Advance**

setting standards

11/04 revised 4/08 FORM NO. 56042452

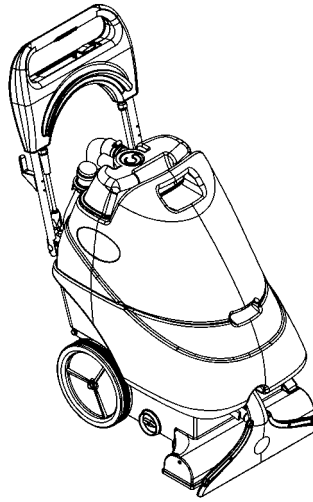

DESCRIPTION	PAGE
Base System	2-3
Brush System	4-5
Decal System	6-7
Handle System 16	8-9
Handle System 18	10-11
Recovery System	12-13
Solution Pump System	14-15
Solution Tank Assembly	16-17
Wiring Diagram 120V/100V (16ST, 16XP, 18FLX, 18ST, AX 410 J)	18-19
Wiring Diagram 230V (AX 410)	20-21
Accessories	22

WHEN ORDERING PARTS

- * Use the 8 digit numbers from the "Ref. No." columns in this parts list.
- * Specify the model and serial number of the machine.
- * Use the space below to record the model and serial number for future reference.

Model _____ Serial No. _____

Before TSBUS2007-959

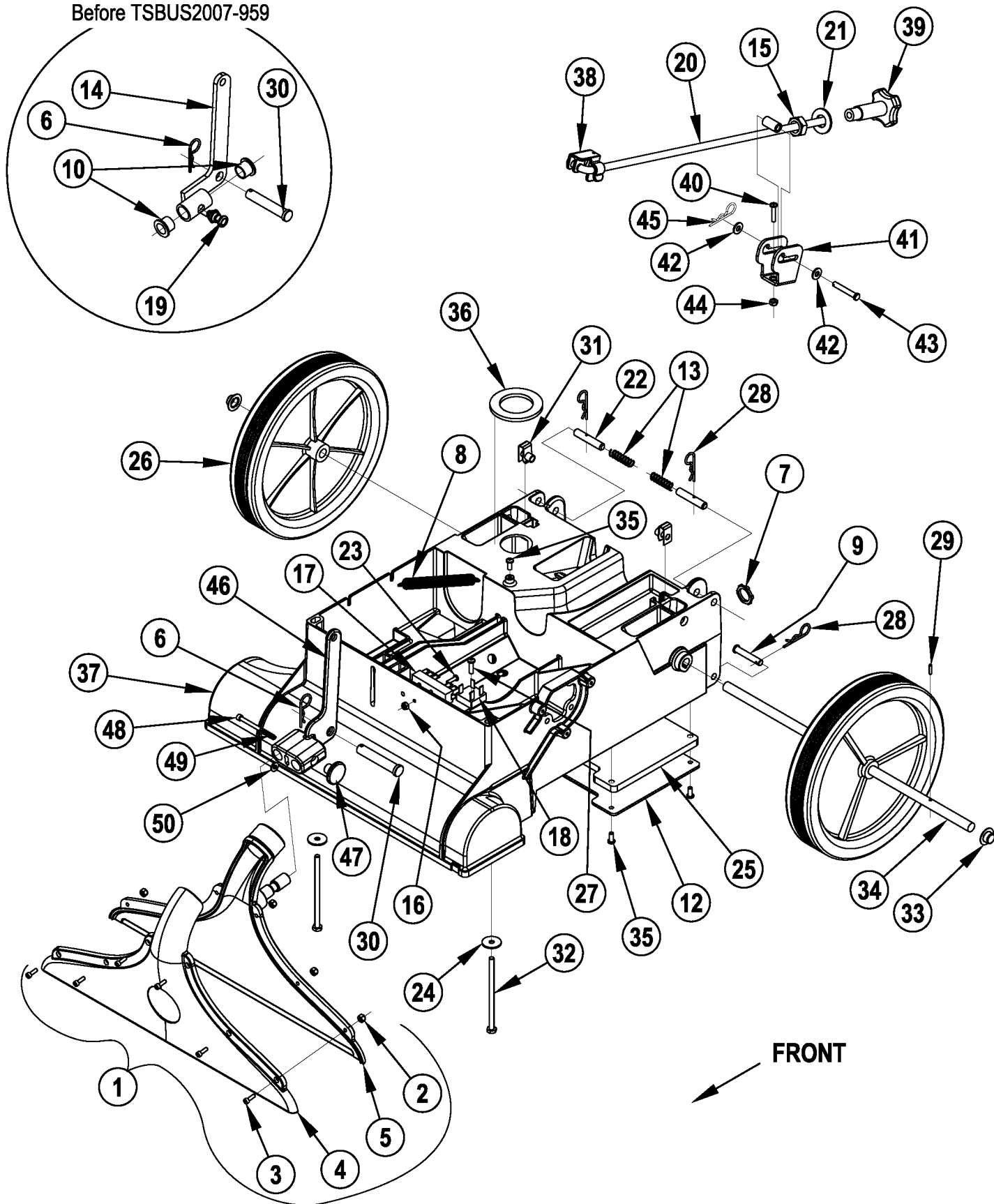

Item	Ref. No.	Qty	Description – Base System
1	56265067	1	Shoe Assembly, 16 (16ST, 16XP, AX 410) (items 2-5)
	56265080	1	Shoe Assembly, 18 (18FLX / 18ST) (items 2-5)
2	56002865	6	Nut, Hex Nyl Loc-Thin 8-32
3	56002101	6	Scr, Soc Hd 8-32 x 0.50
4	56265068	1	Shoe Front, 16
	56265081	1	Shoe Front, 18
5	56265069	1	Shoe Back, 16, Assy
	56265082	1	Shoe Rear, 18, Assy
6	56002959	1	Pin, Cotter Hair
7	56009095	1	Nut, Conduit Lock 1/2-14
8	56398606	1	Spring, Ext .50 x 6.25
9	56321404	2	Clevis Pin .3125 x 1.84 (16ST, 16XP, AX 410)
10#	56171095	2	Bearing, Flange before SN1980731
12	56265172	1	Panel, Exhaust (16XP, 18FLX, 18ST)
	56265148	1	Panel, Exhaust (16ST, AX 410)
13	56228142	2	Spring, Compression
14#	56265116	1	Linkage Weldment, 16 (16ST, 16XP, AX 410) before SN1980731
#	56265144	1	Linkage Weldment, 18 (18FLX, 18ST) before SN1980731
15	56002844	1	Nut, Hex Nyl Loc-Thin 5/8-11
16	56002865	1	Nut, Hex Nyl Loc-Thin 8-32
17	56260071	1	Terminal Block
18	56265103	1	Rectifier, 35 Amp
19#	56365548	1	Lock Pin Assy before SN1980731
20	56265100	1	Rod, Brush Adjustment (16ST, 16XP, AX 410)
	56265111	1	Adjustment Rod Weldment (18FLX, 18ST)
21	56002022	1	Wsh, Fit SAE 5/8
22	56265073	2	Pin, Pivot
23	56002146	1	Scr, Pan Phil 8-32 x .62
24	56009060	2	Wsh, Fit SS .260 x 1.000 x .074
25	56265071	1	Gasket, Exhaust
26	56249505	2	Wheel
27	56003091	1	Scr, Pan Phil Plastite 10-14 x .75
28	56003120	4	Pin, Cotter Hair .0915 x .375 (qty of 2 on 18" models)
29	56003133	1	Pin, Spr .12 x .56
30	56003207	1	Clevis Pin .50 x 2.75
31	56003690	2	Nut, U Multi-Thread M8 x 1.25 (16" models only)
32	56003691	2	Scr Hex Loc SS 1/4-20 x 4.50
33	56009097	2	Nut, Push Cap 1/2
34	56265057	1	Axle
35	56009191	5	Scr, Pan Phil Plastite 10-14 x .50
36	56200573	1	Gasket, Ring 1.75 x 2.75 x .19
37	56265020	1	Base, Extractor, 16 (16ST, 16XP, AX 410)
	56265120	1	Base, Extractor, 18 (18 FLX, 18ST)
38	56265031	1	Clip, Rod
39	56265036	1	Knob, Brush Adjustment
40	56002674	1	Scr, Pan Phil 10-24 x 1.00 (18 FLX, 18ST only)
41	56265119	1	Latch, Adjustment (18 FLX, 18ST only)
42	56002098	2	Wsh, Fit SAE 1/4 (18 FLX, 18ST only)
43	56003193	1	Clevis Pin .25 x 1.625 (18 FLX, 18ST only)
44	56002832	1	Nut, Hex Nyl Loc-Thin 10-24 (18 FLX, 18ST only)
45#	56003120	1	Pin, Cotter Hair .0915 x .375 (18 FLX, 18ST only)
46#	56265237	1	Lever, Brush Adjustment after SN1980730
47#	56265239	1	Knob after SN1980730
48#	56003761	1	Scr, Soc HD SS 10-32 x 1.50 after SN1980730
49#	56201448	1	Spring, Compression after SN1980730
50#	56002916	1	Wsh, Fit SAE SS #10 after SN1980730

= Revised or new since last update

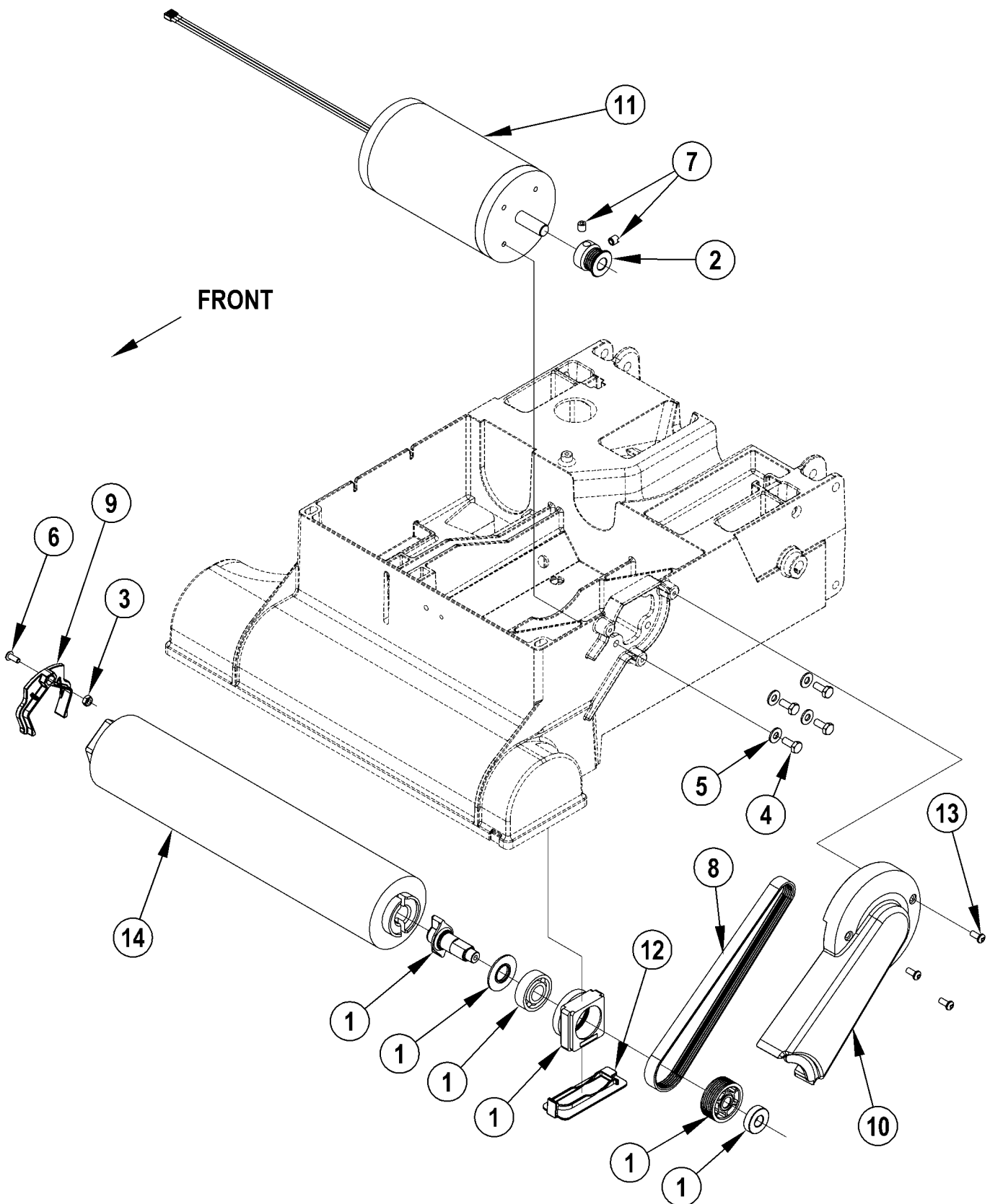

04-11

BRUSH SYSTEM

06-10

AquaClean™/AX 410**5**

Item	Ref. No.	Qty	Description
1	56265204	1	Bearing/Spindle Kit
	NA	1	Spindle, Drive
	NA	1	Washer, Bearing
	NA	1	Bearing, Block
	NA	1	Sheave Poly-V 6J17
	NA	1	Bearing, Ball
	NA	1	Bearing, Ball
2	56262558	1	Sheave, Poly-V
3	56002849	1	Nut, Hex Nyl Loc-Thin SS 10-24
4	56001854	4	Scr, Hex Hd 1/4-20 x .50
5	56002098	4	Wsh, Flt SAE 1/4
6	56002900	1	Scr, Pan Phil SS 10-24 x .50
7	56009131	2	Scr, Soc Set Loc 5/16-18 x .31
8	56265024	1	Belt, Poly V
9	56265043	1	Clip, Brush Retainer
10	56265047	1	Belt Guard
11	56265075	1	Motor, 115 VDC, 1/3 HP (16ST, 16XP, 18FLX, 18ST)
	56265076	1	Motor, 230 VDC, 1/3 HP (AX 410)
12	56265091	1	Cover, Pulley
13	56009191	3	Scr, Pan Phil Plastite 10-14 x .50
14	56265044	1	Brush Assembly 16
	56265046	1	Brush, 16
	56265099	1	Brush Assembly 18
	56265065	1	Brush, 18

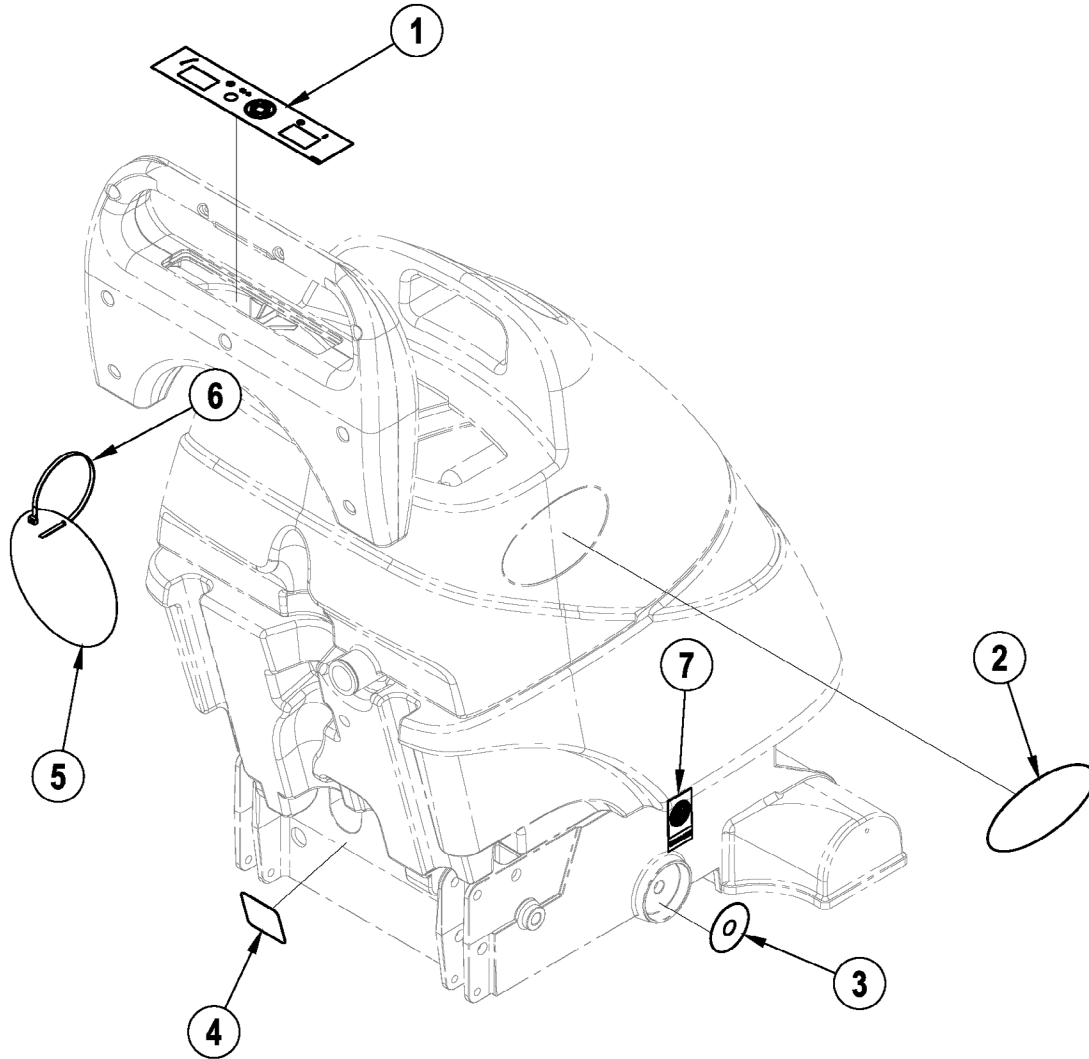

04-11

DECAL SYSTEM

08-4

AquaClean™/AX 410**7**

Item	Ref. No.	Qty	Description
1#	56016720	1	Decal, Panel (Nilfisk AX 410 only)
	56016716	1	Decal, Panel (16ST, 16XP, AX 410 J)
#	56016717	1	Decal, Panel (Advance 18FLX, 18ST only)
2#	56016724	2	Decal, Nilfisk AX 410 (all Nilfisk AX 410)
#	56016721	2	Decal, AquaClean XP (Advance 16XP only)
#	56016725	2	Decal, AquaClean ST (Advance 16ST, 18ST only)
#	56016722	2	Decal, AquaClean FLX (Advance 18FLX only)
3#	56016715	1	Decal, Nozzle Selector (Advance 16XP, 18FLX, all Nilfisk AX 410)
4	56016718	1	Decal, Brush Pressure
5	56040958	1	Tag, CRI (Advance only)
6#	56478523	1	Tie, Cable (Advance only)
7	56317151	1	Decal, CRI Bronze (Advance only)

= Revised or new since last update

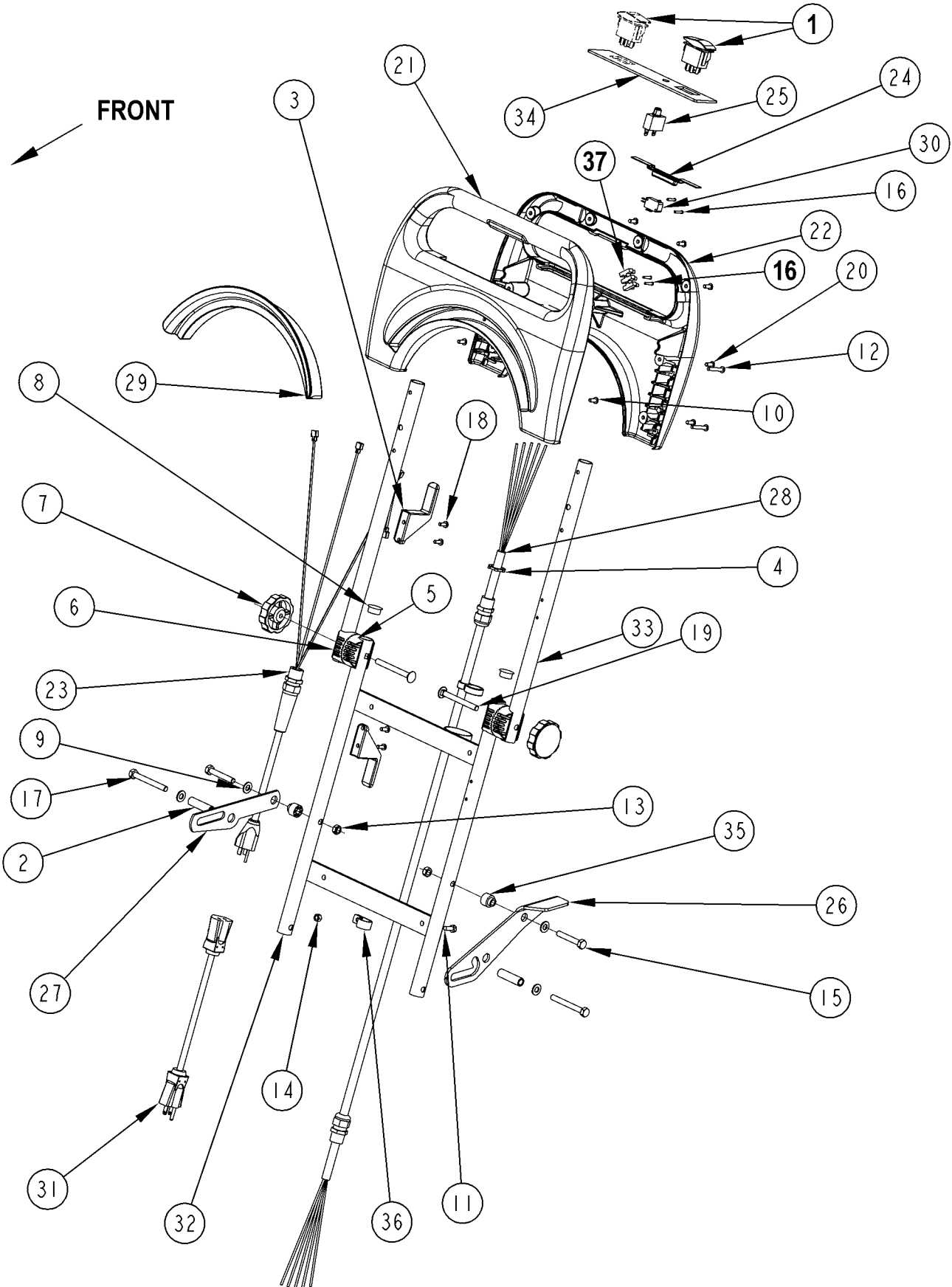

04-11

HANDLE SYSTEM 16

08-4

AquaClean™/AX 410

9

Item	Ref. No.	Qty	Description
1	56265097	1	Switch, Rocker (16ST, 16XP, AX 410 J)
	56265107	2	Switch, Rocker (AX 410)
2	56265167	2	Bushing .34 x .50 x 1.50
3	56262518	2	Hook, Cord
4	56009095	2	Nut, Conduit Lock 1/2-14
5	56264118	2	Ratchet
6	56264123	2	Ratchet
7	56302167	2	Knob
8	56900041	2	Plug, Cap
9	56001939	4	Wsh, Flt SAE 5/16
10	56001993	3	Scr, Pan Phil 10-24 x .50
11	56003441	1	Scr, Hex Nyl Loc M6-1 x 16mm
12	56002824	4	Scr, Pan Phil 10-24 x 1.25
13	56003389	2	Nut, Hex Nyl Loc M8-1.25
14	56003350	1	Nut, Hex M6 x 1.0
15	56003210	2	Scr, Hex M8-1.25 x 50mm
16	56003092	2	Scr, Pan Phil Plastite 4-20 x .62 (qty of 4 on AX 410)
17	56003700	2	Scr, Hex M8-1.25 x 70mm
18	56009029	4	Scr, Pan Phil Thd Form 10-24 x .50
19	56009136	2	Scr, Carriage 5/16-18 x 3.00
20	56009191	9	Scr, Pan Phil Plastite 10-14 x .50
21	56265028	1	Cover, Handle, Front
22	56265029	1	Cover, Handle, Rear
23	56265035	1	Cord, Pigtail (16XP)
	56265115	1	Cord, Pigtail (AX 410)
	56265162	1	Cord, Power 14/3, SJT (16ST)
	56265217	1	Power Cord, 40ft. Japan (AX 410 J)
24	56265053	1	Button, Spray
25	56265056	1	Circuit Breaker W/Boot (16ST, 16XP, AX 410 J)
	56265104	1	Circuit Breaker W/Boot (AX 410)
26	56265058	1	Latch, Handle
27	56265059	1	Strap, Handle
28	56265085	1	Main Cable Assy
29	56265090	1	Hook, Handle Cover
30	56265098	1	Switch, SPDT Snapaction
31	56265112	1	Cord Set, 14/3 x 50' YEL (16XP only)
32	56265123	1	Lower Handle Weldment
33	56265143	2	Tube, Handle
34	56265159	1	Panel, Control (16ST, 16XP, AX 410 J)
	56265055	1	Panel, Control (AX 410)
35	56265199	2	Bushing, Flange
36#	56486112	1	Clamp, P
37	56183523	1	Terminal Block (AX 410 only)

= Revised or new since last update

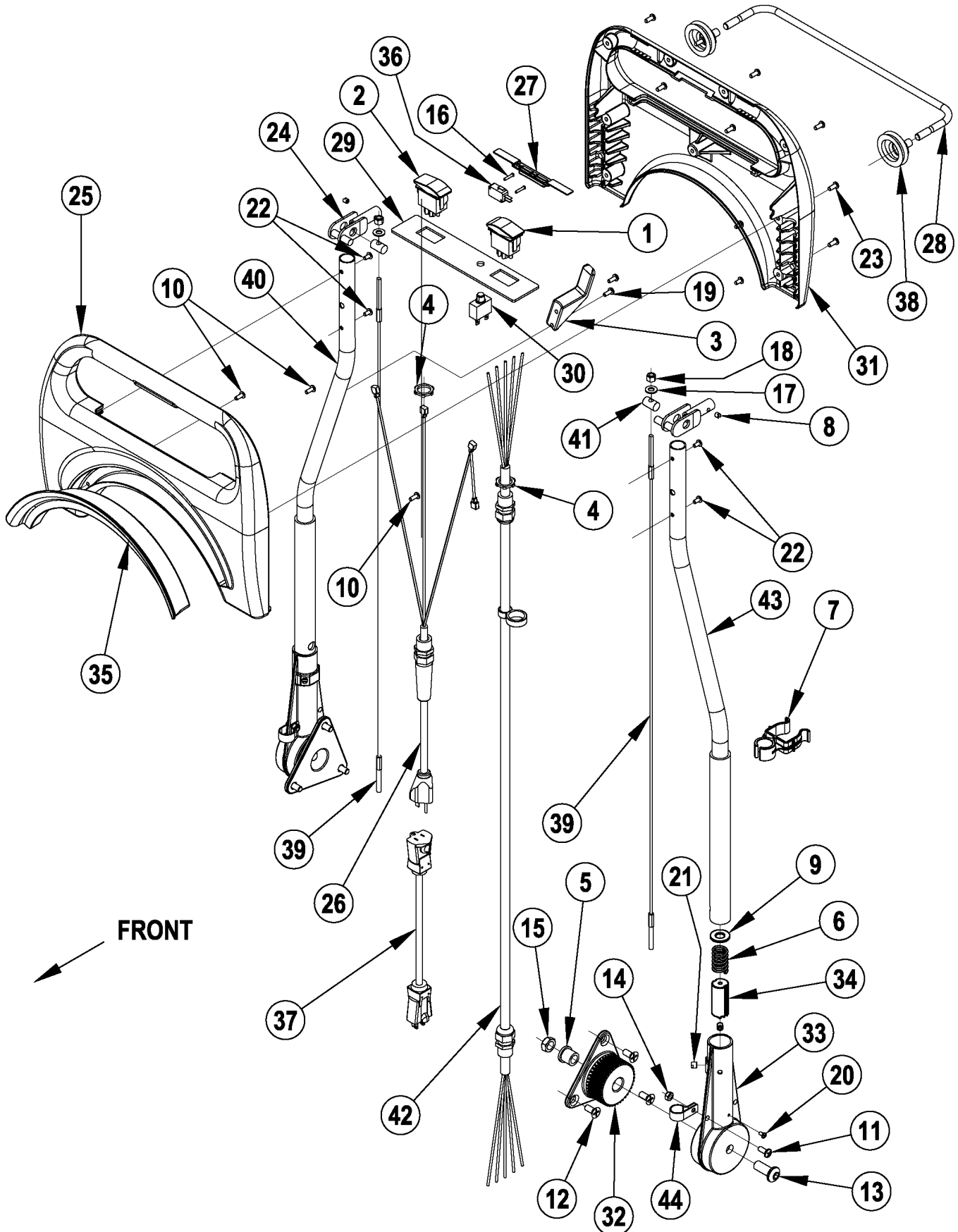

04-11	HANDLE SYSTEM 18		
08-4	AquaClean™/AX 410		11

Item	Ref. No.	Qty	Description
1	56265097	1	Switch, Rocker (vacuum)
2	56265107	1	Switch, Rocker (solution)
3	56262518	1	Hook, Cord
4	56009095	2	Nut, Conduit Lock 1/2-14
5	56111503	2	Bearing, Flange
6	56056519	2	Compression Spring
7	56265169	1	Clip, Tool (18FLX)
8	56001841	2	Scr, Soc Set Loc 1/4-20 x .25
9	56009003	2	Wsh, Flt .516 x .938 x .075
10	56001993	3	Scr, Pan Phil 10-24 x .50
11	56002066	2	Scr, Pan Phil 1/4-20 x .62 (qty of 1 on 18ST)
12	56002395	6	Scr, Flt Phil 5/16-18 x .75
13	56009341	2	Scr, Button Soc 1/2-13 x 1.50
14	56002840	2	Nut, Hex Nyl Loc-Thin 1/4-20 (qty of 1 on 18ST)
15	56002843	2	Nut, Hex Nyl Loc-Thin 1/2-13
16	56003092	2	Scr, Pan Phil Plastite 4-20 x .62
17	56002098	2	Wsh, Flt SAE 1/4
18	56003284	2	Nut, Hex Nyl Loc 1/4-28
19	56009029	2	Scr, Pan Phil Thd Form 10-24 x .50
20	56009066	2	Scr, Pan Phil 8-32 x .31
21	56009131	4	Scr, Soc Set Loc 5/16-18 x .31
22	56009139	4	Scr, Pan Phil Loc 10-24 x .38
23	56009191	9	Scr, Pan Phil Plastite 10-14 x .50
24	56265241	2	Handle Adjustment Pivot NOTE 1
25	56265028	1	Cover, Handle, Front
26	56265035	1	Cord, Pigtail
27	56265053	1	Button, Spray
28	56265054	1	Bail, Handle Release
29	56265055	1	Panel, Control
30	56265056	1	Circuit Breaker W/Boot (5 amps)
31	56265062	1	Cover, Flip Handle, Back
32	56265074	2	Gear, Handle
33	56265083	2	Handle Socket
34	56265084	2	Lock, Handle
35	56265090	1	Hook, Handle Cover
36	56265098	1	Switch, SPDT Snapaction
37	56265112	1	Cord Set, 14/3x50' Yel
38	56265128	2	Bellows, Handle
39	56265147	2	Wire Rope Assy
40	56265157	1	Tube, Handle
41	56265242	2	Pin NOTE 2
42	56265192	1	Main Cable Assy
43	56265197	1	Tube, Handle
44#	56486112	1	Clamp, P

= Revised or new since last update

NOTE 1: Pivot Weldment 56265023 is obsolete and has been replaced by Handle Adjustment Pivot 56265241 in production. Order Kit 56265191 when replacing 56265023.

NOTE 2: Pin 56265164 is obsolete and has been replaced by Pin 56265242 in production. Order Kit 56265191 when replacing 56265164

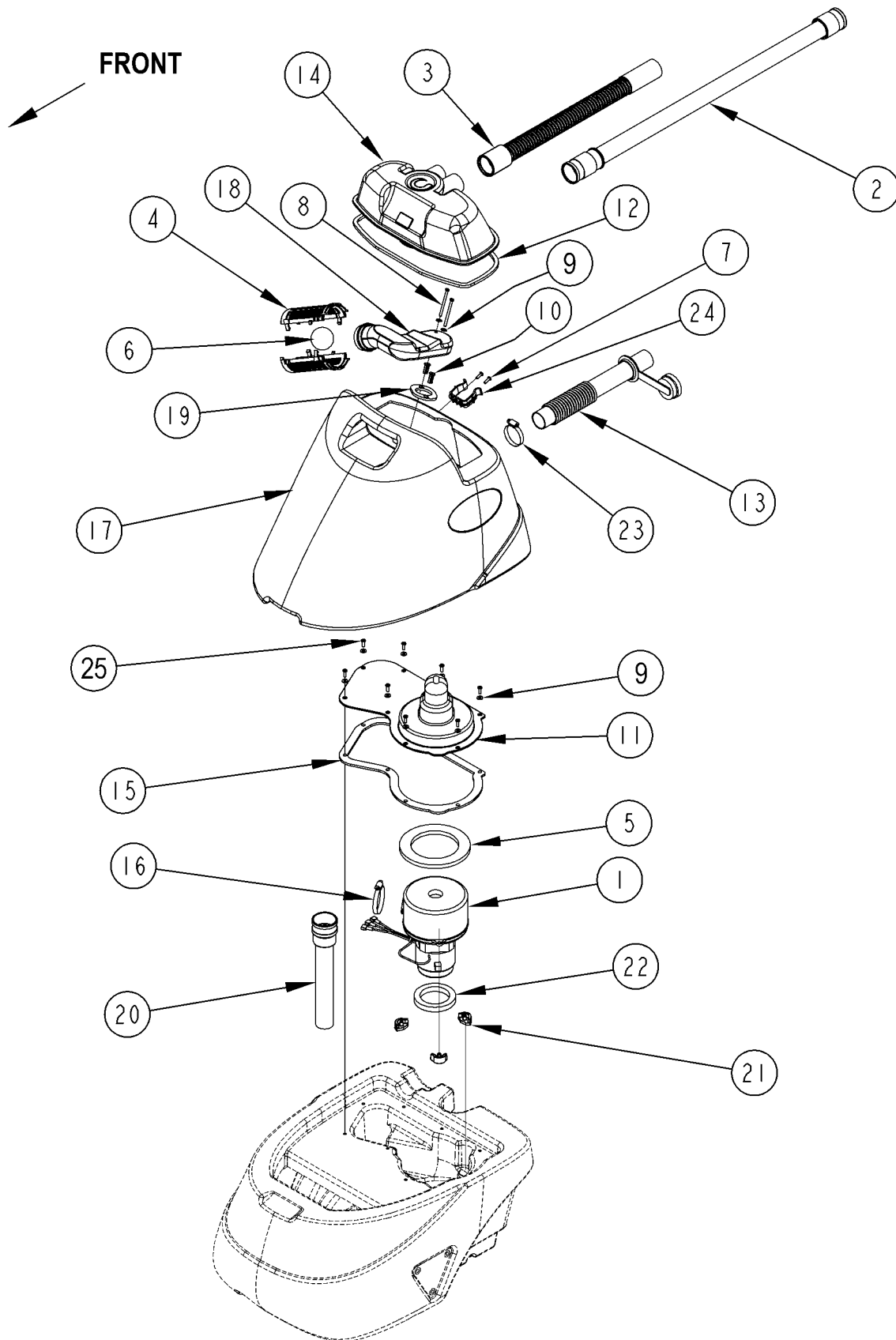

04-11

RECOVERY SYSTEM

06-10

AquaClean™/AX 410**13**

Item	Ref. No.	Qty	Description
1	56265096	1	Vac Motor, 120V (16ST, 16XP, 18FLX, 18ST)
	56264453	1	Carbon Brushes for 56265096 (one pair)
	56265117	1	Vac Motor, 240V (AX 410)
	56264452	1	Carbon Brushes for 56265117 (one pair)
2	56265145	1	Vac Hose 1.50 x 33.00 x 975018 (16XP, 18FLX, AX 410)
	56265142	1	Vac Hose 1.50 x 48.00 x 975018 (16ST)
	56265211	1	Vac Hose 1.50 x 54.00 x 975018 (18ST)
3	56265158	1	Vac Hose 1.50 Stretch (16XP, 18FLX, AX 410)
4	56324497	2	Cage, Float
5	56385437	1	Gasket
6	56391690	1	Ball, Float
7	56002124	2	Scr, Pan Phil 10-24 x .62 NOTE 1
8	56003131	2	Scr, Hex SS 10-24 x 2.50
9	56009205	10	Wsh, Flt SS #10
10	56009374	2	Jack Nut
11	56265030	1	Cover, Vac Motor
12	56265032	1	Gasket
13	56265034	1	Hose, Drain 1.5 Inch NOTE 1
14	56265064	1	Recovery Lid
15	56265072	1	Gasket, Vac Cover
16	56440213	1	Clamp, Hose SAE #32
17	56265127	1	Tank, Recovery, 18 (18FLX, 18ST)
	56265022	1	Tank, Recovery, 16 (16ST, 16XP, AX 410)
	56265210	1	Tank, Recovery, ST (1st generation 16ST)
18	56265134	1	Duct, Float
19	56265163	1	Gasket
20	56265202	1	Vac Hose Assy
21	56314484	3	Mount, Vibration
22	56314760	1	Gasket, Vacuum Duct
23	56329145	1	Clamp, Hose SAE #24 NOTE 1
24	56331154	1	Clamp, Plastic NOTE 1
25	56002900	8	Scr, Pan Phil SS 10-24 x .50

NOTE 1: Not used on 1st generation 16ST models.

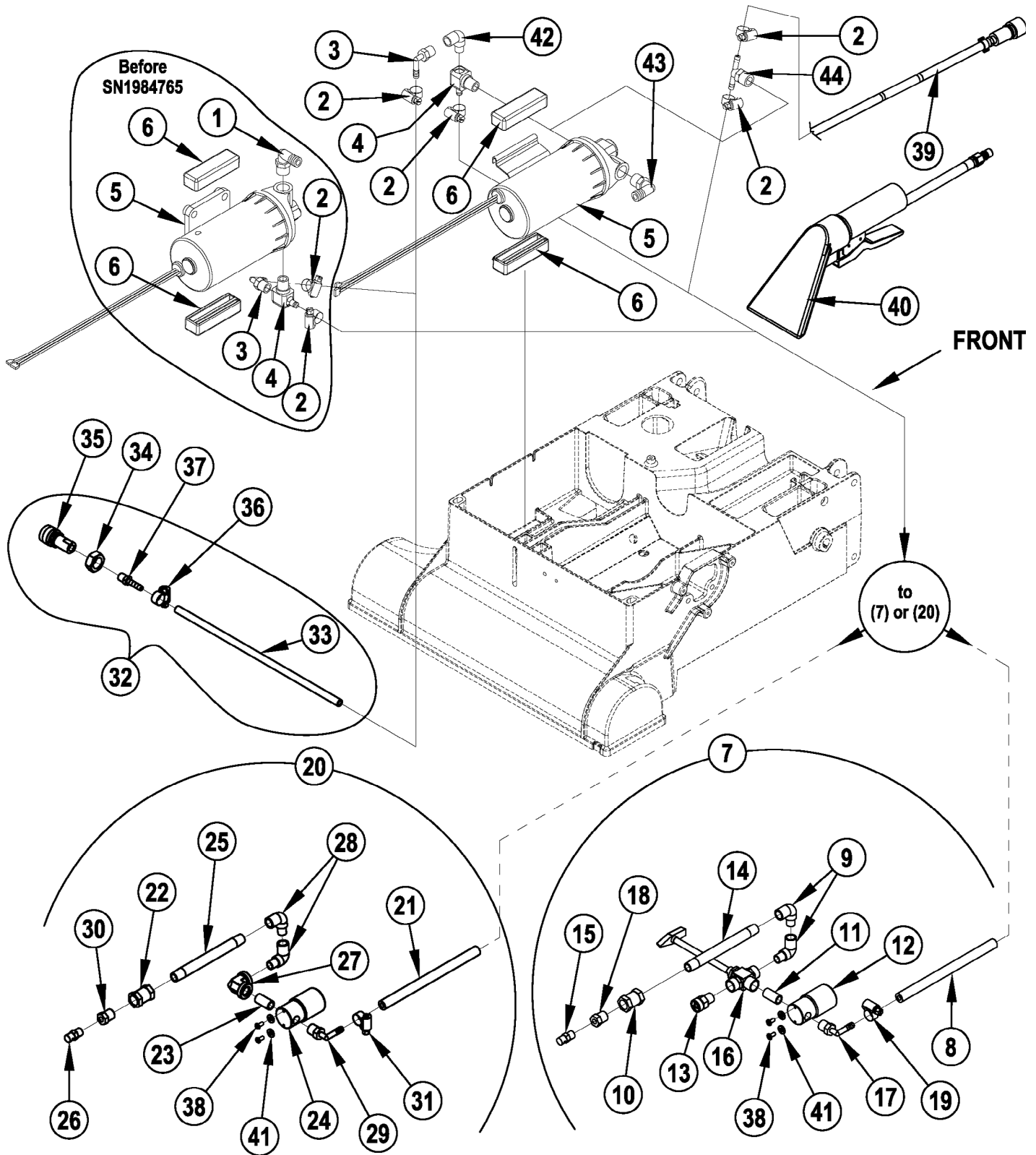

Item	Ref. No.	Qty	Description
1#	56900069	1	Barb, 90 Elbow 1/2 X 3/8NPT before SN1984765
2	56756364	2	Clamp, Hose SAE #4
3#	56470138	1	Barb, 90 Elbow 1/4 x 1/4NPT NOTE 3
4#	56264382	1	Adapter, Barbed NOTE 3
5#	56265051	1	Pump 115V (16ST, 16XP, 18FLX, 18ST, AX 410 J) before SN1984765
#	56265050	1	Pump 230V (AX 410) before SN1984765
#	56265224	1	Pump 115V (16ST, 16XP, 18FLX, 18ST, AX 410 J) after SN1984764
#	56265223	1	Pump 230V (AX 410) after SN1984764
6	56265033	2	Mount, Pump
7	56265039	1	Nozzle/Valve Assy (16) (16XP, AX 410 J) (items 8-19)
	56265140	1	Nozzle/Valve Assy (16) 230V (AX 410) (items 8-19)
	56265139	1	Nozzle/Valve Assy (18) (18FLX) (items 8-19)
8#	56260841	1	Hose, Polyester Braid, 7.00 before SN1984765
#	56264346	1	Hose, Polyester Braid, 10.50 after SN1984764
9	56369632	2	Elbow, 90 Street
10	56900032	1	Coupling
11	56150223	1	Nipple, 1/4NPT x .88/1.12
12	56265037	1	Valve, Solenoid 115V (16XP, 18FLX, AX 410 J) TSBUS2007-966
	56265114	1	Valve, Solenoid 230V (AX 410) TSBUS2007-966
13	56265038	1	Quick Veejet W/ Body
14	56265040	1	Nipple, 1/4NPT x 5.00, Brass
15	56265052	1	Nozzle, Spray
16	56265121	1	Valve, 3-Way Ball (16XP, AX 410)
	56265122	1	Valve, 3-Way Ball (18FLX)
17	56470138	1	Barb, 90 Elbow 1/4 x 1/4NPT
18	56740214	1	Bushing, Reducer
19	56756364	1	Clamp, Hose SAE #4
20	56265160	1	Nozzle/Valve Assy (16) (16ST, 18ST) (items 21-31)
21	56260841	1	Hose, Polyester Braid, 7.00 before SN1984765
#	56264346	1	Hose, Polyester Braid, 10.50 after SN1984764
22	56900032	1	Coupling
23	56150223	1	Nipple, 1/4NPT x .88/1.12
24	56265037	1	Valve, Solenoid 115V TSBUS2007-966
25	56265040	1	Nipple, 1/4NPT x 5.00, Brass
26	56265052	1	Nozzle, Spray
27	56340782	1	Elbow, Pipe 1/4 NPT Brass
28	56369632	2	Elbow, 90 Street
29	56470138	1	Barb, 90 Elbow 1/4 x 1/4NPT
30	56740214	1	Bushing, Reducer
31	56756364	1	Clamp, Hose SAE #4
32	56265170	1	Hose Connection Assembly (16ST, 18ST) (items 33-37)
33	56220043	1	Solution Feed Hose before SN1984765
#	56264346	1	Solution Feed Hose after SN1984764
34	56009078	1	Nut, Hex Jam SS 5/8-18
35	56265208	1	Socket, 1/8 FPT
36	56756364	1	Clamp, Hose SAE #4
37	56369594	1	Barb, Adapter 1/4 x 1/8NPT
38	56003018	2	Scr, Pan Phil SS 8-32 x .38
39	56265168	1	Hose Assembly (16XP, 18FLX, all AX 410)
40	56220109	1	Hand Tool Assembly (16XP, 18FLX, all AX 410)
41	56002875	2	Wsh, Flt SAE SS #8
42#	56369632	1	Elbow, 90 Street NOTE 3 after SN1984764
43#	56900069	1	Barb, 90 Elbow 1/2 x 3/8 NPT NOTE 2
44#	56507993	1	Tee, Barb 1/4 x 3/8 NPT NOTE 1

= Revised or new since last update

NOTE 1: Tee 56507993 replaced items (56264382, 56470138 & 56369632) on the Aquaclean 18FLX model 56265001 after October 2007.

NOTE 2: Elbow 56900069 replaced Barb Adapter 56409507 after November 2007.

NOTE 3: Used on all models EXCEPT the Aquaclean 18FLX model 56265001.

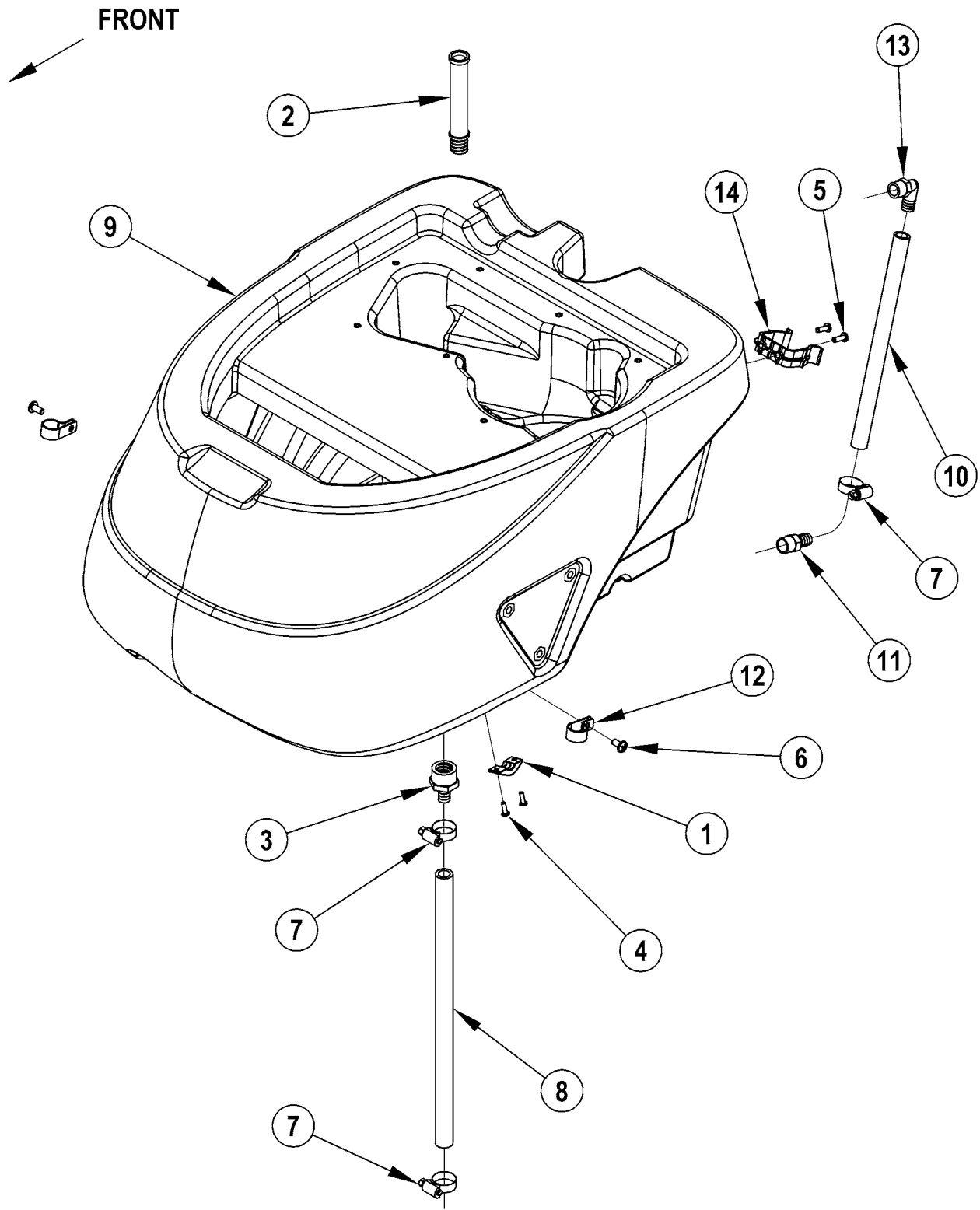

04-11

SOLUTION TANK ASSEMBLY

08-4

AquaClean™/AX 410

17

Item	Ref. No.	Qty	Description
1	56264119	1	Clamp, Power Cord (18FLX, 18ST)
2	56264137	1	Screen
3	56262190	1	Barb
4	56002003	2	Scr, Pan Phil 8-32 x .50 (18FLX, 18ST)
5	56002124	2	Scr, Pan Phil 10-24 x .62
6	56002145	2	Scr, Pan Phil 1/4-20 x .50 (18FLX / qty of 1 on 18ST)
7	56219932	3	Clamp, Hose SAE #6
8#	56387302	1	Hose, Spiral .50 before SN1984765
#	56266134	1	Hose, Spiral .50 after SN1984764 NOTE1
9	56265126	1	Tank, Solution, 18 (18FLX, 18ST)
	56265021	1	Tank, Solution, 16 (16ST, 16XP, AX 410)
10	56265216	1	Hose, PVC Clear 11.00
11	56409507	1	Barb, Adapter 1/2 x 3/8NPT
12#	56486112	2	Clamp, P (18FLX / qty of 1 on 18ST)
13	56900069	1	Barb, 90 Elbow 1/2 x 3/8NPT
14	56331154	1	Clamp, Plastic

= Revised or new since last update

NOTE 1: Hose 56266108 has been replaced by Hose 56266134.

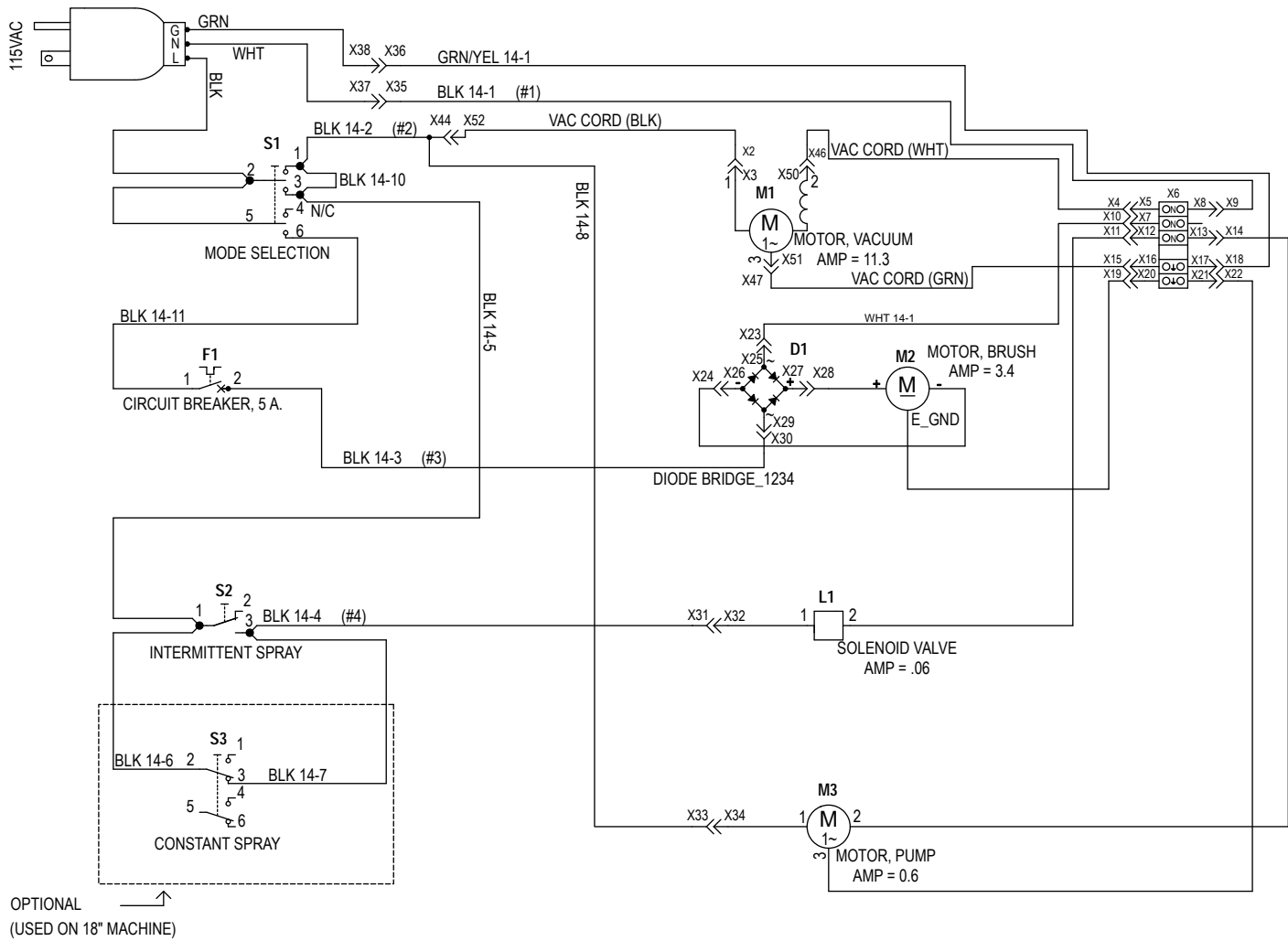

04-11

WIRING DIAGRAM 120V/100V (16ST, 16XP, 18FLX, 18ST, AX 410J)

08-4

AquaClean™/AX 410**19**

Item	Ref. No.	Qty	Description
D1	56265103	1	Rectifier, 35 Amp
F1	56265056	1	Circuit Breaker, 5 Amp
L1	56265037	1	Valve, Solenoid 115V TSBUS2007-966
M1	56265096	1	Motor Vacuum, 120V
	56264453	1	Carbon Brushes for 56265096 (one pair)
M2	56265075	1	Motor, Brush 115 VDC, 1/3 HP
M3#	56265051	1	Pump 115V (16ST, 16XP, 18FLX, 18ST, AX 410 J) before SN1984765
#	56265224	1	Pump 115V (16ST, 16XP, 18FLX, 18ST, AX 410 J) after SN1984764
S1	56265097	1	Switch, Mode Selection
S2	56265098	1	Switch, Solution Spray
S3	56265107	1	Switch, Constant Spray (18FLX only)
*	56265187	1	Wire Assembly (16ST, 16XP, 18FLX, 18ST, AX 410 J)
*	56265102	1	Wire Assembly (16ST, 16XP, 18FLX, 18ST, AX 410 J)
*	56265087	1	Wire Assembly (16ST, 16XP, 18FLX, 18ST, AX 410 J)
*	56265108	2	Wire Assembly (18FLX, 18ST)

* = Not Shown

= Revised or new since last update

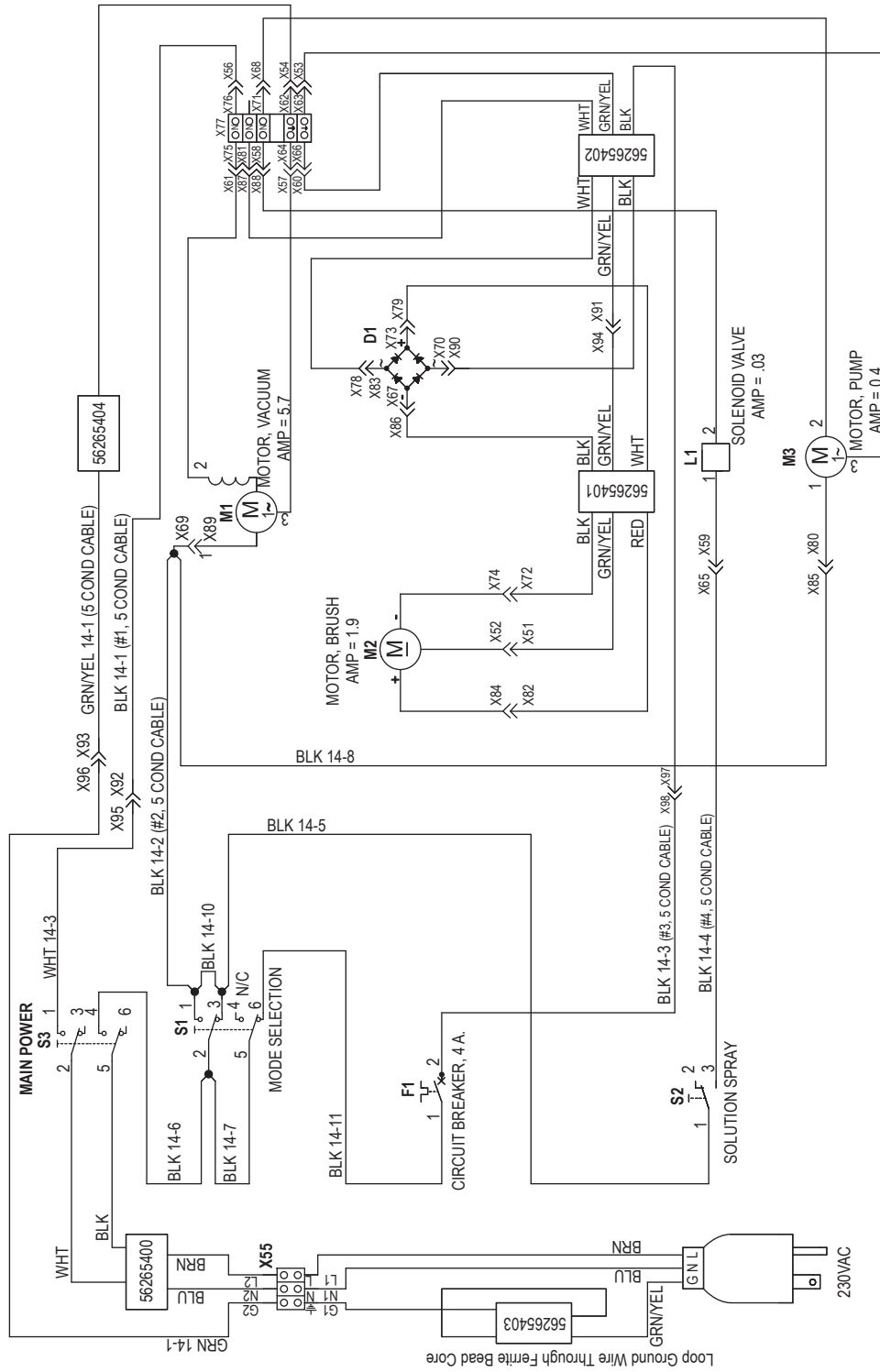

Item	Ref. No.	Qty	Description
D1	56265103	1	Rectifier, 35 Amp
F1	56265104	1	Circuit Breaker, 4 Amp
L1	56265114	1	Valve, Solenoid 230V TSBUS2007-966
M1	56265117	1	Motor Vacuum, 240V
	56264452	1	Carbon Brushes for 56265117 (one pair)
M2	56265076	1	Motor, Brush 230 VDC, 1/3 HP
M3#	56265050	1	Pump 230V (AX 410) before SN1984765
#	56265223	1	Pump 230V (AX 410) after SN1984764
S1	56265107	1	Switch, Mode Selection
S2	56265098	1	Switch, Solution Spray
S3	56265107	1	Switch, Main Power
*	56265187	1	Wire Assembly
*	56265087	1	Wire Assembly
*	56265110	1	Wire Assembly
*	56265400	1	EMI Filter Assembly
*	56265401	1	EMI Filter Assembly
*	56265402	1	EMI Filter Assembly
*	56265403	1	EMI Ferrite Bead Core
*	56265404	1	EMI Ferrite Bead Core

* = Not Shown

= Revised or new since last update

ACCESSORIES

04-11

22**AquaClean™/AX 410**

07-4

OPTIONAL BRUSHES

Brush Assembly Description	16"	18"
Nylon Brush Assembly	56265044	56265099
Blue Brush Assembly	56265175	56265177
240 Grit Brush Assembly	56265176	56265178

ACCESSORY TOOLS

Ref. No.	Description
56314402	Wand Assembly w/Soft and Hard Floor Tools
56265173	Wand Assembly w/Soft Floor Tool
56262209	Stand Up Wand
56220109	Hand Tool
56220070	Upholstery Hand Tool
56265174	15' Hose w/Waterline
56265112	Locking Extension Cord
56265368	8' Hose w/Waterline
56265150	Hard Floor Tool
56265309	Plug Adaptor Kit
56265305	Drag Wand
56265306	Scrub N Vac Wand
56250314	14" Scrub/Vac Tool

