



 EQUIPMENT

 PARTS

 RENTALS

 SERVICE

 SUPPLIES



**HAMMERHEAD**<sup>®</sup>  
**650RS**



**HAMMERHEAD**<sup>®</sup>  
**750RS**

**USE  
AND  
MAINTENANCE  
MANUAL**

**CONTACT US**

 800.6.Bortek

 717.737.7591

 [Orders@BortekIndustries.com](mailto:Orders@BortekIndustries.com)

 [BortekIndustries.com/CUSTOMERLINK](http://BortekIndustries.com/CUSTOMERLINK)

## Introduction

### **Preface**

Dear customer, It is our desire that the good characteristics of the Hammerhead should justify the confidence you demonstrated by making this purchase. Prior to the first use, carefully read the chapter "Safety Information" as this will ensure your safe operation of the machine.

Your own safety, as well as the safety of others, depends to a great extent on how the machine is moved and operated. Therefore, this operation and maintenance manual must be read and understood prior to the machine being used for the first time.

The manual provides valuable information about operation, service and maintenance. The warning symbols as used in this manual identifies items relevant to safety. Please observe the safety provisions (see chapter "Safety Information").

Your authorized Manufacturer dealer will be pleased to answer further questions regarding the vehicle or the operation and maintenance manual.

Please be advised explicitly that we cannot accept any legal issues out of the contents of this manual.

If repair work has to be performed make sure that only genuine spare parts are used; only genuine spare parts may guarantee a dependable machine.

We reserve the right for technical improvement..

Valid as of: January 2014

### **Proper use**

The machine is a vacuum scrubbing machine for wet cleaning of hard-surfaced floors. Using the machine beyond this scope of application will be deemed improper use; The manufacturer cannot be held liable for consequential damages; the user alone bears the risk.

The term of proper use also includes operation, maintenance and repair work to be performed in compliance with the manufacturer's specifications.

The Hammerhead may only be used by persons that are familiar with the machine and aware of possible hazards involved.

If modifications to the machine are made in absence of the manufacturer's prior consent, the latter cannot be held liable for damage resulting from such unauthorized modification.

### **Notes on warranty**

The terms of the sales contract apply. Damages are not subject to warranty if they are due to non-compliance with the maintenance and service provisions. The maintenance work has to be performed by an authorized Bortek Industries, Inc. service center and confirmed in the "Maintenance certificate" which is the warranty document.

The following is excluded from warranty: fuses, natural wear, damages caused by overload, inexperienced handling and unauthorized modification of the machine. Moreover, any claim for warranty cannot be accepted if damages of the machine are caused by fitting parts or accessories without the manufacturer's prior and explicit consent or by non-compliance with the maintenance instructions.

### **Acceptance of the machine**

Upon arrival, check machine for possible damages in transit. Follow unpacking instructions on shipping pallet. Each unit has been tested and thoroughly inspected before shipment. Any damage is the responsibility of the delivery carrier who should be notified immediately.



# Table of Contents



<b>Introduction</b> . . . . .	<b>2</b>	<b>4</b>	<b>Technical Data</b> . . . . .	<b>14</b>
Preface . . . . .	2			
Proper use . . . . .	2			
Notes on warranty . . . . .	2			
Acceptance of the machine . . . . .	2			
<b>1 Safety information</b> . . . . .	<b>4</b>	<b>5</b>	<b>Maintenance and Care</b> . . . . .	<b>15</b>
1.1 Safety and Warning Symbols . . . . .	4	5.1	Manufacturer System Maintenance . . . . .	15
1.2 General Provisions . . . . .	4	5.2	Maintenance Document . . . . .	16
1.3 Provisions for Operation . . . . .	5	5.3	Maintenance Schedule . . . . .	16
1.4 Maintenance instructions . . . . .	5	5.4	Battery Systems . . . . .	18
1.5 Specific Hazards . . . . .	6	5.4.1	Charge Batteries . . . . .	19
1.6 Information for Protection of Environment . . . . .	6	5.4.2	Low Discharge Signal sender (LDS) . . . . .	19
1.7 Labels at the Machine . . . . .	10	5.4.3	Maintenance of Drive Batteries . . . . .	19
<b>2 First Operation</b> . . . . .	<b>8</b>	5.4.4	Remove Batteries . . . . .	19
2.1 Instruction . . . . .	8	5.4.5	Install Batteries . . . . .	19
2.2 Initial charging procedure . . . . .	8	5.4.6	Disposal of Batteries . . . . .	19
2.3 Before Putting into Operation . . . . .	8	5.5	Solution Tank . . . . .	20
2.4 Start Machine . . . . .	8	5.5.1	Fill Solution Tank . . . . .	20
2.5 Operation . . . . .	8	5.5.2	Empty Solution Tank . . . . .	20
2.6 Stop Machine . . . . .	8	5.5.3	Clean Solution Filter . . . . .	20
2.7 After Work . . . . .	9	5.6	Recovery Tank . . . . .	21
2.8 Transporting the Machine . . . . .	9	5.6.1	Empty Recovery Tank . . . . .	21
2.9 Tie-Down Points . . . . .	9	5.6.2	Clean Recovery Tank . . . . .	21
<b>3 Operation</b> . . . . .	<b>10</b>	5.6.3	Clean Suction Filter . . . . .	21
3.1 Method of Operation . . . . .	10	5.7	Disc Brush Deck . . . . .	22
3.1.1 Brush Deck . . . . .	10	5.7.1	Clean Brushes . . . . .	22
3.1.2 Solution Tank . . . . .	10	5.7.2	Change Brushes . . . . .	22
3.1.3 Squeegee . . . . .	10	5.7.3	Change Roller Bumper . . . . .	22
3.1.4 Recovery Tank . . . . .	10	5.7.4	Change Sealing Strip . . . . .	22
3.1.5 Traction Drive . . . . .	10	5.8	Squeegee . . . . .	23
3.1.6 Batteries and Charger . . . . .	10	5.8.1	Clean Squeegee . . . . .	23
3.1.7 Options . . . . .	10	5.8.2	Change Squeegee Blades . . . . .	23
3.2 Operating and Indicating Elements . . . . .	11	5.8.3	Adjust Squeegee Blades . . . . .	24
3.2.1 Operating Panel . . . . .	11			
3.2.2 At the Machine . . . . .	12			

## 1 Safety information

### 1.1 Safety and Warning Symbols

All paragraphs in this manual referring to your personal safety, the safety of your machine and the environment protection are attributed one of the following warning symbols:

Safety Symbols	Description
WARNING 	Indicates a hazardous situation which could result in death or serious injury.
NOTICE 	Indicates a potentially hazardous situation which may result in equipment or property damage.

Additional Symbols	Description
Ecological hazard 	Indicates the use of substances representing an inherent danger to the health of the environment
Note 	Indicates important or additional information.

### 1.2 General Provisions

- Apart from the provisions contained in this instruction manual, the general safety provisions and the accident prevention regulations as imposed by law have to be complied with.
- Before taking your machine into operation, carefully read the instruction manual as well as other separate instructions for accessories or attached implements and comply with all points mentioned there during work.
- Persons being trained by qualified Manufacturer technicians only are authorized to operate, service and repair the machine.
- You are advised to thoroughly study the safety instructions since precise knowledge helps prevent errors during machine operation and thus guarantee proper use of the machine.
- The operating instructions have to be at hand at the place of use of the machine, and therefore have to be kept readily available at the machine.
- When selling or letting the machine for rent, hand out these documents to the new owner/operator and have the transfer certified!
- The warning and instruction plates attached to the machine contain valuable advice about safe operation. Immediately replace incomplete or illegible labels.
- As far as safety standards are concerned, use only genuine spare parts!

### 1.3 Provisions for Operation

- Before first operation of the machine, fully charge the battery with an initial charging procedure and comply with the operating instructions of the charger as well as with those of the battery manufacturer. Manufacturer cannot be held liable for damages resulting from an insufficient initial charge.
- Before taking into operation, check the machine for operational safety! Immediately repair any malfunctions!
- It is indispensable for the operator to get acquainted with all attached implements and controls as well as with their function before operation begins. Once you have started to work, no time will be left to do so!
- When working with the machine use firm and skid proof shoes.
- The machine may be used only on such surfaces clearly specified by the owner or his authorized representative.
- When working with the machine, pay strict attention to any persons in the close vicinity.
- Start moving immediately after brush deck has switch on otherwise the brush might leave traces on the floor. Lift the brush head before moving over obstacles (doorsteps).
- Only fold open empty recovery tank.
- Use only cleaning agents suitable for automatic machines (low-foaming) and comply with the instructions for use, disposal and with the warning information specified by the cleaning agent's manufacturer.
- The machine is not designed for collecting hazardous, flammable or explosive dusts or substances.

- Usage of the machine in explosive areas is prohibited.
- Remove the key to avoid unauthorized use of the machine.
- Before transporting the machine, lift the squeegee and the brush deck. Adapt driving habits to local conditions.
- The machine may be used only for operation on flat floors with a maximum inclination of up to 2 %.

### 1.4 Maintenance instructions

- The daily and weekly maintenance and repair task must be performed by a qualified operator. For further maintenance and repair work please contact your local Manufacturer service center.
- Observe the maintenance activities and intervals set out in the instruction manual.
- Maintenance and repair work may be carried out only by means of appropriate tools.
- Have the machine checked for safe condition by an expert at regular intervals (recommendation: at least once yearly) as well as after modifications or repair.
- Spare parts have to equal the technical requirements as specified by the manufacturer! Genuine spare parts guarantee compliance with these requirements.
- Switch off the power and remove the key before inspecting the machine or performing any maintenance work.
- To prevent the machine from being used by unauthorized persons, the control key must be removed.
- When performing work at the electrical system, be sure to disconnect the battery plug.

- Make sure to protect the recovery tank against accidental closing or tilting down before working in the area of a lifted tank lid.
- Do not clean the electrical parts by means of high-pressure cleaning equipment.
- The use of aggressive detergents is prohibited.
- Let the machine dry after cleaning. Do not store the machine with liquid remaining in the tanks
- All protective devices must be in place before operating the machine.

### 1.5 Specific Hazards

#### Electric system

- Only use genuine fuses with specified ratings.
- In case of malfunction of the electric system, shut the machine down immediately and have it serviced.
- Only qualified personnel are authorized to work on the electrical system and only according to electro-technical rules.
- Inspect/check the electrical equipment of the machine at regular intervals. Clear up any defects immediately, such as loose connections or damaged cables..

#### Battery

- Observe the operating instructions of the battery manufacturer.
- Never place metal objects or tools on batteries - short-circuit hazard!
- Due to alteration of the center of gravity, only use batteries as released and at the prescribed position only.
- Charge batteries only in areas with sufficient ventilation. – Explosion hazard!

### 1.6 Information for Protection of Environment

- Observe the legal directives and local regulations for disposal of detergents.
- Used batteries labelled as recyclable contain reusable economic goods. These batteries must not be added to the normal waste.

# Safety information

## 1.7 Labels at the Machine

The following safety and information labels are legibly attached to the machine. Replace missing or illegible labels immediately.

Manufacturer nameplate (Fig. 1/1)

Machine identification number (Fig. 1/2)

Recovery tank drain hose (Fig. 1/3)

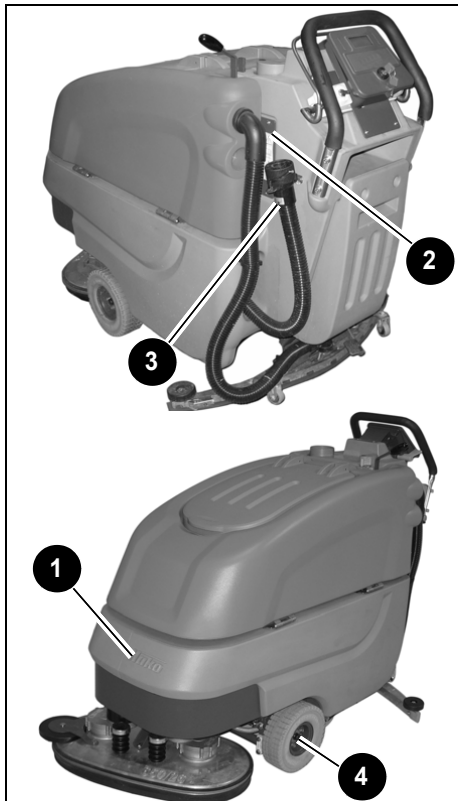
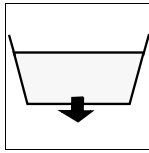
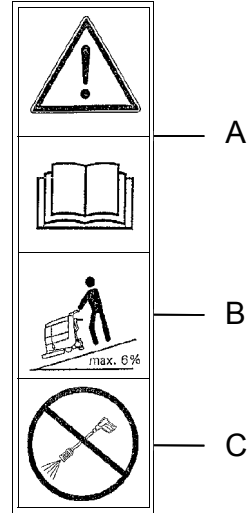

Fig.1

A = Read and observe the instruction manual

B = Maximum inclination of 2 %

C = Do not clean the machine by means of high-pressure cleaning equipment



## 2 First Operation

### 2.1 Instruction

Only persons trained by qualified Bortek technicians are authorized to operate, service and repair the machine. Operators must read and understand this manual before operating or maintaining this machine.

### 2.2 Initial charging procedure

**NOTICE** Before first operation of the machine, fully charge the battery with an initial charging procedure and comply with the operating instructions of the charger as well as with those of the battery manufacturer. Bortek cannot be held liable for damages resulting from an insufficient initial charge.

### 2.3 Before Putting into Operation

Complete the following inspections before taking the machine into operation:

1. Check the area around the machine for signs of leakage. Hoses, lines and tanks must be free from any leakage or damage.
2. Install brushes and squeegee, see maintenance chapter.
3. Install batteries and connect battery plug, see maintenance chapter.
4. Check battery charge and recharge if required. An initial charge is required before first operation of the machine.
5. Empty recovery tank and clean it if required, see maintenance chapter.
6. Refill solution tank and add cleaning agent according to the manufacturer's recommendations.

**NOTICE** Use only cleaning agents suitable for automatic machines (low-foaming) and comply with the instructions for use, disposal

and with the warning information specified by the cleaning agent's manufacturer.

### 2.4 Start Machine

Proceed with the following to set the machine to operating mode:

- Disconnect mains plug of the charger from outlet and fasten to holder.
- Switch on machine by actuation of key switch from position (0) to position (1).

### 2.5 Operation

1. Switch on the machine.
2. Use lever (Fig5/4) to lower squeegee. Vacuum motor switches on automatically.
3. Use solution control (Fig5/3) to set the desired flow rate.
4. Use pedal (Fig5/1) to lower brush deck. The solution supply switches on automatically.
5. Use speed control knob (Fig.4/9b) to adjust work speed. Use the direction switch (Fig.4/9a) to select forward or reverse. Pull the bail handle (Fig.4/9c) to start moving.

**NOTICE** Start moving machine immediately after switching on the brush deck, otherwise the brushes leave traces on the floor. Lift brush deck before passing over steps and other obstacles.

### 2.6 Stop Machine

When the bail handle is released it automatically returns to the neutral position. The machine stops. Secure the machine against unintentional movements or against being started.



## 2.7 After Work

1. Move machine to a suitable site for maintenance.
2. Stop machine, lift squeegee and brush deck and remove the key.
3. Empty and clean recovery tank.



Observe the legal directives and local regulations for disposal of detergents.

4. Check solution filter.
5. Check seals and suction hose.
6. Check operating fluid levels, function and setting.
7. Charge batteries.
8. Clean the machine.

Empty the solution tank before shutting down the machine for a longer time.

**NOTICE** Do not clean the electrical parts by means of high-pressure cleaning equipment.

## 2.8 Transporting the machine

To transport the machine to the work area, switch it on, lift-out squeegee and brush deck, pull the bail handle start movement.

## 2.9 Tie-down points

When transporting on a vehicle or trailer, the machine has to be secured. Tie the machine down firmly by using the front eye bolts (Fig. 2/1) and the rear chassis (Fig. 2/2) as tie-down points.

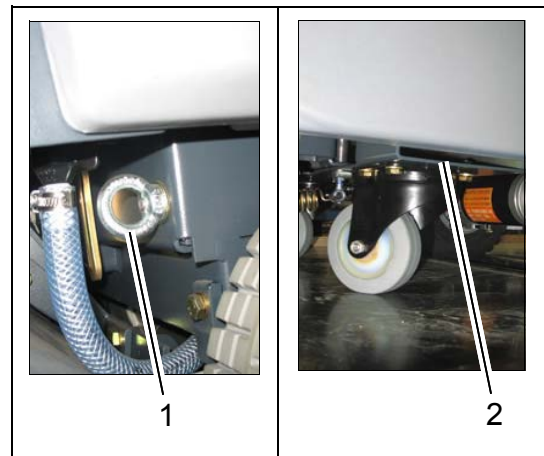

Fig.2

## 3 Operation

### 3.1 Method of Operation

#### General

The Hammerhead is a vacuum scrubbing machine for wet cleaning of hard-surfaced floors.

#### 3.1.1 Brush Deck

Lower brush deck (Fig. 3/1) via pedal before scrubbing. The brushes rotate and water supply switches on automatically. When the machines stopped, brushes and water supply switch off automatically.

#### 3.1.2 Solution Tank

Fill the solution tank (Fig. 3/2) after removing the cover. The solution tank holds 18.5 gallons and the filling level can be checked visually (through transparent hose). Regulation of water amount is available via solution control.

#### 3.1.3 Squeegee

The movable squeegee (Fig. 3/3) consists of the squeegee lift mechanism, the vacuum motor and squeegee blades. The soiled water is wiped from the floor by means of squeegee blades. Squeegee is lowered via hand lever. Simultaneously, the vacuum motor switches on. The vacuum motor works independent of direction of travel and even if the machine stops. Second actuation of the hand lever lifts the squeegee up again and vacuum is automatically switched off with a delay of 15 seconds.

#### 3.1.4 Recovery Tank

The soiled water is taken from squeegee to the recovery tank (Fig. 3/4) by vacuum motor and suction hose.

#### 3.1.5 Traction Drive

The machine features a continuous traction drive (Fig. 3/6). The electronic traction drive control realises modification of travel speed, direction as well as dynamic braking.

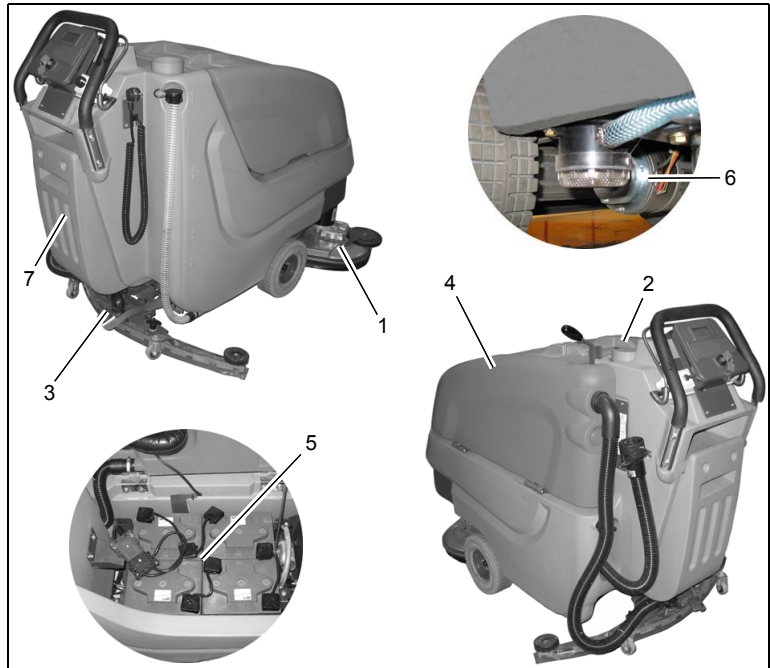

Fig.3

#### 3.1.6 Batteries and Charger

The machine is equipped with 235 Ah batteries (Fig. 3/5), an automatic charger unit (Fig. 3/7) and a low discharge signal sender (LDS) for protection against low discharge.

#### 3.1.7 Options

- Extraction hose including suction pipe, joint nozzle and wet suction nozzle
- Mop holder and tool-box for cleaning utensils



Accessories such as brushes, rollers, pads, pad holder with centerlock and squeegee blades are available. Contact your Manufacturer Dealer for more information.

## 3.2 Operating and Indicating Elements

### 3.2.1 Operating Panel

- 1 Display
- 2 Key switch
- 3 Battery charge indication
- 4 LDS indicator
- 5 Symbol brush drive
- 6 Symbol vacuum motor drive
- 7 Hourmeter
- 8 Symbol service indicator
- 9 Drive direction control (9a) with speed control knob (9b) and bail handle (9c)

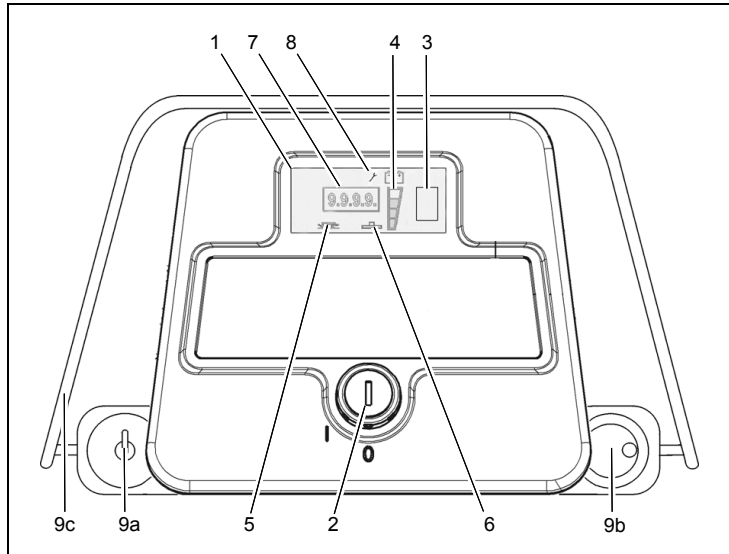
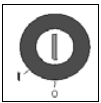

Fig.4

#### Display (Fig. 4/1)

This panel allows centralized monitoring of functions and detection of all available operating modes.



The key switch turns the electrical system on and off.



Remove the key to avoid unauthorized use of the machine.

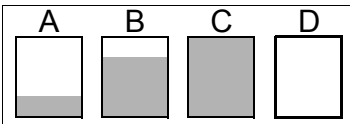

#### Battery charge indication (Fig. 4/3)

Battery charge indication appears on the panel during the charging procedure and shows the current charge condition of batteries during the procedure.

The following symbols appear:

- Battery symbol A < charge of 20 %
- Battery symbol B = charge of 80 %
- Battery symbol C = charge of 100 %
- Battery symbol D (flashes) = error

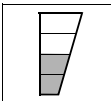

#### LDS indicator (Fig. 4/4)

Upon switching on, the LDS indication is output on the panel to show the current battery charge condition during

operation. Additional Information see chapter maintenance.

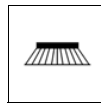

#### Symbol brush drive (Fig. 4/5)

This symbol appears when brush drive is switched on.

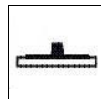

#### Symbol vacuum motor (Fig. 4/6)

This symbol appears when the vacuum motor is switched on.

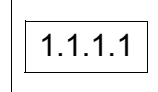

#### Hourmeter (Fig. 4/7)

Upon switching on, the hourmeter briefly displays the software version and the last error code. Then the current operating hour level is shown.

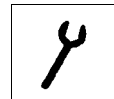

#### Symbol service indicator (Fig. 4/8)

The service indicator lights after occurrence of a system error and cleaning or transporting procedure is interrupted. In addition to the service indicator, a 4-digit code is displayed on the hourmeter.

**3.2.2 At the Machine**

- 1 Brush deck pedal
- 2 Opening of solution tank
- 3 Solution control
- 4 Squeegee lever
- 5 Solution filter
- 6 Recovery tank drain hose
- 7 Solution tank drain hose (Solution level indication)
- 8 Brush ejector
- 9 Power connection charger unit

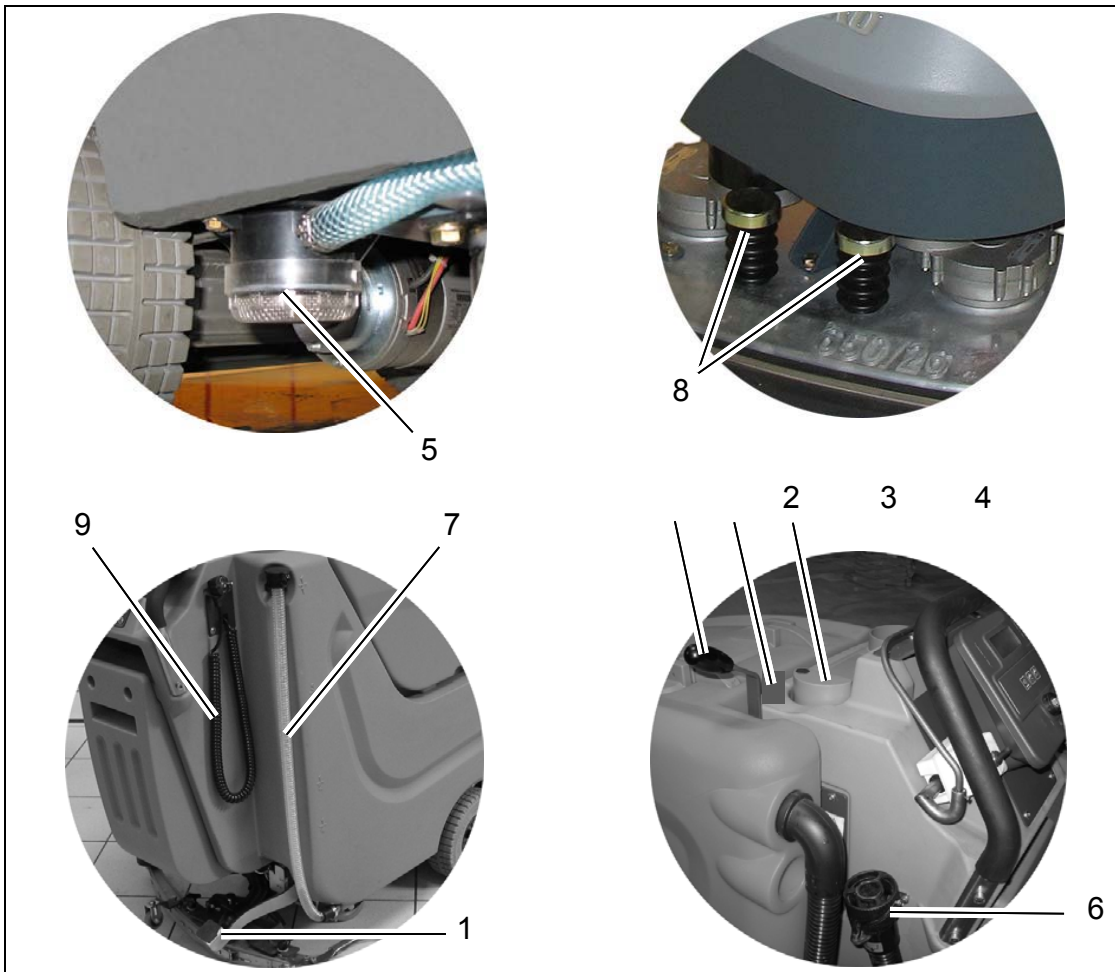

**Fig.5**

### **Drive direction control with speed control knob and bail handle (Fig. 4/9)**

The drive direction control (9a) is used to control the driving direction (forward or reverse). The bail handle must be pulled in order to drive. The speed can be adjusted continuously by means of the speed control knob (9c). The machine stops when the bail handle is released (deadman function).



Secure the machine against rolling away before leaving it unattended.

### **Brush deck pedal (Fig. 5/1)**

Use this pedal to lift and lower the brush deck.

### **Opening of solution tank (Fig. 5/2)**

The solution tank is filled after folding up the opening.

### **Solution control (Fig. 5/3)**

Squeegee water supply is regulated by hand valve. The solution flow can be regulated between 0 gal/min and 0.9 gal/min.

### **Squeegee lever (Fig. 5/4)**

Use the hand lever to lift and lower the squeegee. This will deactivate or activate the vacuum motor.

### **Solution tank filter (Fig. 5/5)**

While solution flows from tank to brush deck, it is cleaned by the filter element.

### **Recovery tank drain hose (Fig. 5/6)**

This hose allows draining the collected soiled water from the tank.

### **Solution tank drain hose (Fig. 5/7)**

This hose allows draining the solution tank.

### **Brush ejector (Fig. 5/8)**

The brush ejector makes brush removal fast and easy.

### **Power connection (Fig. 5/9)**

The power connection supplies the charger unit with power.

## 4 Technical Data

Machine length	62.25 in	158 cm
Machine height	43.7 in	111 cm
Machine width without Squeegee	29.75 in	75.6 cm
Machine width with Squeegee	38.5 in	98 cm
Working width	29.6 in	75.2 cm
Squeegee width	38.25 in	97.2 cm
Surface performance theoretical	39061 ft <sup>2</sup> /h	3629 m <sup>2</sup> /h
Service voltage	24 V	24 V
Nominal power drive motor	260 W	260 W
Nominal power vacuum motor	520 W	520 W
Nominal power brush motor	2x720 W	2x720 W
Number of brushes	2 Qty.	2 Qty.
Diameter of brushes	15.0 in	38 cm
Working speed	3,0 mph	5,0 km/h
Solution tank	18.5 gal	70 l
Recovery tank	19.8 gal	75 l
Weight without batteries and solution	398 lb	181 kg
Weight with solution and batteries	724 lb	328 kg

<b>Noise emission</b>		
The sound pressure level measured under maximum conditions of use (LwA) according to DIN EN 60335-2-72 amounts to:	dB (A)	82
The sound pressure level measured (at the ear of the driver) under normal conditions of use (LpA) according to DIN EN 60335-2-72 amounts to:	dB (A)	67
Measurement inaccuracy (KpA):	dB (A)	1,6
<b>Vibration</b>		
The frequency weighted acceleration measured according to DIN EN ISO 5349 which have an effect upon the upper limbs (hand-arm-system) amounts under normal working conditions:	m/s <sup>2</sup>	< 2,5

## 5 Maintenance and Care

### General



Before proceeding to maintenance and care work you are advised to read and comply with the Safety Information chapter!

Compliance with the recommended maintenance work will ensure that you always have a reliable machine available.

Daily or weekly maintenance and repair work may be executed by the driver/operator having been trained accordingly. Further Manufacturer system maintenance work must be completed by qualified personnel only. Please contact your local Manufacturer Service Center or Manufacturer contract dealer. We cannot be held liable for damages resulting from non-compliance with these instructions.

Please indicate the machine's serial number with any enquiry or spare part order, see paragraph 1.7 - Identification.

### 5.1 Manufacturer System Maintenance

The Manufacturer System Maintenance:

- guarantees reliable operability of the Manufacturer machines (preventive maintenance)
- minimizes operating costs, repair costs and maintenance costs
- ensures long service life and operability of the machine

The Manufacturer System Maintenance is structured in separate modules and determines specific technical works to be executed as well as the intervals for such maintenance works. For any specific maintenance type, the replacement parts are determined and listed in spare part kits.

### System Maintenance K:

To be performed by the customer in accordance to the maintenance and care instructions contained in the operating instructions (daily or weekly). The operator will be instructed upon delivery of the machine.

### System Maintenance I :

(every 125 hours of operation)

To be performed by qualified personnel of authorized Manufacturer Service Center in accordance with the machine-specific system maintenance including spare part kit.

### System Maintenance II:

(every 250 hours of operation)

To be performed by qualified personnel of authorized Manufacturer Service Center in accordance with the machine-specific system maintenance including spare part kit.

### System Maintenance S:

(every 500 hours of operation safety check)

To be performed by qualified personnel of authorized Manufacturer Service Center in accordance with the machine-specific system maintenance including spare part kit.

# Maintenance and Care

## 5.2 Maintenance Document

<p>Handing over</p> <p>Upgrade Test drive Handing over to the customer Instruction carried out on: at _____ operating hours</p>	<p>System Maintenance I 125 operating hours Workshop stamp</p> <p>carried out on: at _____ operating hours</p>	<p>System Maintenance II 250 operating hours Workshop stamp</p> <p>carried out on: at _____ operating hours</p>	<p>System Maintenance I 375 operating hours Workshop stamp</p> <p>carried out on: at _____ operating hours</p>
<p>System Maintenance S 500 operating hours Workshop stamp</p> <p>carried out on: at _____ operating hours</p>	<p>System Maintenance I 625 operating hours Workshop stamp</p> <p>carried out on: at _____ operating hours</p>	<p>System Maintenance II 750 operating hours Workshop stamp</p> <p>carried out on: at _____ operating hours</p>	<p>System Maintenance I 875 operating hours Workshop stamp</p> <p>carried out on: at _____ operating hours</p>
<p>System Maintenance S 1000 operating hours Workshop stamp</p> <p>carried out on: at _____ operating hours</p>	<p>System Maintenance I 1125 operating hours Workshop stamp</p> <p>carried out on: at _____ operating hours</p>	<p>System Maintenance II 1250 operating hours Workshop stamp</p> <p>carried out on: at _____ operating hours</p>	<p>System Maintenance I 1375 operating hours Workshop stamp</p> <p>carried out on: at _____ operating hours</p>

## 5.3 Maintenance Schedule System Maintenance Customer

The daily and weekly maintenance intervals must be performed by the customer/operator.

To be performed	Interval	
	daily	weekly
Fill solution tank and proceed to chemical agent dosage	○	
Charge batteries	○	
Check brush deck and clean if required	○	
Check squeegee and clean if required	○	
Clean tank lid seal of the recovery tank	○	
Empty recovery tank. Clean recovery tank and suction filter	○	
Check brushes/pads and replace if required		○
Clean suction hose of recovery tank		○
Check squeegee blades and turn around or replace if required		○
Clean drain hose of solution tank		○
Check solution supply to brushes and clean if required		○
Check solution filter and clean if required		○
Test drive and function test		○



## Maintenance and Care

### System Maintenance I

The following maintenance work must be performed by an authorized Manufacturer Service workshop.

To be performed	Interval
	every 125 hours of operation
Check battery charger	○
Check tank lid seal of the recovery tank and replace if required	○
Check drain hose of the recovery tank and replace if required	○
Grease joints at the brush lift mechanism	○
Check wheel fixing screws and tighten (24 lb ft) if required	○
Check condition of tires	○
Grease joints at the squeegee holder	○
Test drive and function test	○

### System Maintenance II

The following maintenance work must be performed by an authorized Manufacturer Service workshop.

To be performed	Interval
	every 250 hours of operation
Perform maintenance works according to System Maintenance I	○
Inspect steering rollers for tread damages and bearing slackness and replace if required	○
Check drain hose of the recovery tank and replace if required	○
Check roller bumper of the brush deck and replace if required	○
Check suction hose for tight fit and damages and replace if required	○
Check supporting wheel of the squeegee and replace if required	○
Test drive and function test	○

## System Maintenance S (Safety check)

The following maintenance work must be performed by an authorized Manufacturer Service workshop at least once a year.

To be performed	Interval
	every 500 hours of operation
Perform maintenance works according to System Maintenance II	○
Clean traction drive motor from carbon dust and check carbon brushes for smooth operation and wear and replace carbon brushes if required	○
Clean brush motors from carbon dust and check carbon brushes for smooth operation and wearing and replace carbon brushes if required	○
Test drive and function test	○

### 5.4 Battery Systems

- 1 LDS display
- 2 Charger indicator
- 3 Charger
- 4 Mains cable charger
- 5 Battery connector
- 6 Batteries
- 7 Recovery tank
- 8 Support
- 9 Wiring diagram

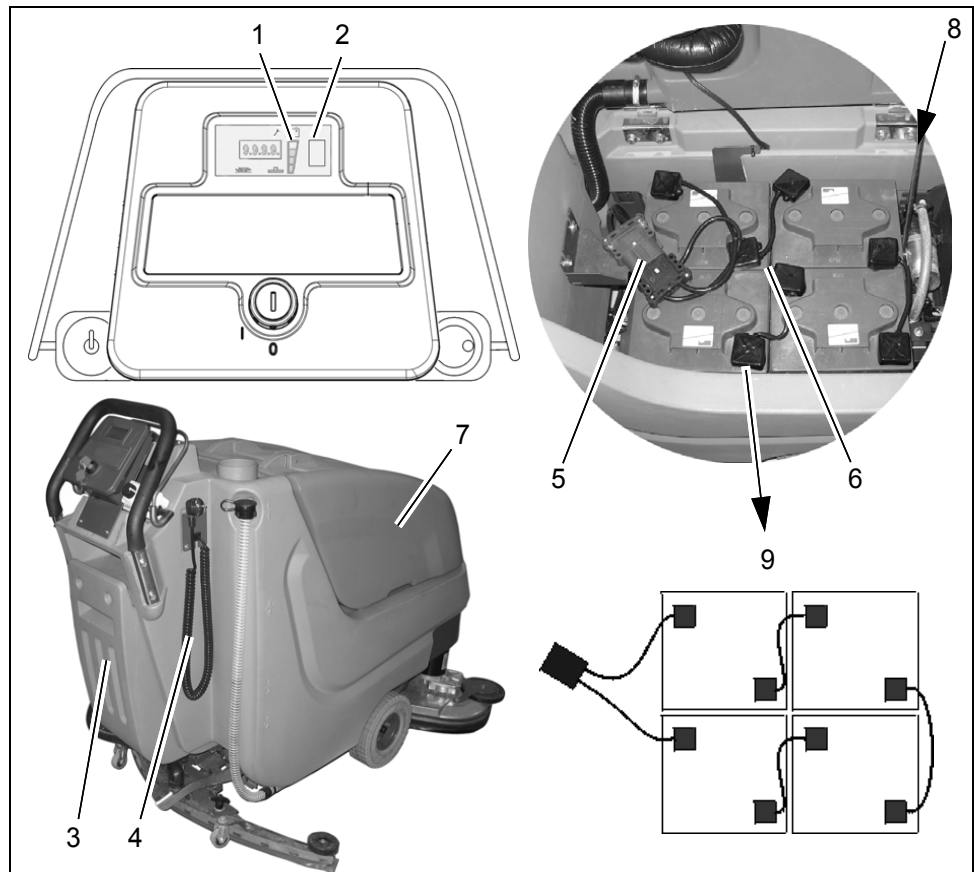

Fig.6



Handling and changing the batteries may be performed only by maintenance staff.

### 5.4.1 Charge Batteries

Use the integrated battery charger (Fig. 6/3) to charge batteries. Proceed to connection of the charger by means of the mains cable (Fig. 6/4) with safety plug. Charging batteries is recommended if at least one bar of the LDS display has extinguished after operation of the machine. On this behalf you are requested to observe the operating instructions of the charger 88-60-2723 as well as the operating instructions of the battery manufacturer. In case it is intended to change the type of battery the charger has to be adjusted only by Bortek contract workshops.

**NOTICE** Charge the batteries properly before starting the machine for the first time. Manufacturer cannot be held liable for battery damage resulting from failure to initially charge batteries.



Provide for sufficient ventilation of areas where batteries are charged. – Explosion hazard!

### 5.4.2 Low Discharge Signal sender (LDS)

The machine has been equipped with a charge indicator to preclude the batteries from low discharge. This low discharge signal sender has been integrated into the electronics. If other batteries are used, readjustment of the low discharge signal sender is required.

**NOTICE** Only Manufacturer contract workshops are authorized to adjust the low discharge signal sender.

### 5.4.3 Maintenance of Drive Batteries

Refer to operating instructions 88-60-2556 for information on care of drive batteries.

### 5.4.4 Remove Batteries

1. Park machine on level ground.
2. Switch off machine by key switch.
3. Open empty recovery tank (Fig. 6/7) and secure by support (Fig. 6/8).
4. Disconnect battery connector (Fig. 6/5).
5. Disconnect battery connection cables.
6. Remove batteries.

### 5.4.5 Install Batteries



Due to alteration of the center of gravity, only use batteries as released and at the prescribed position only.

1. Switch off machine by key switch.
2. Open empty recovery tank (Fig. 6/7) and secure by support (Fig. 6/8).
3. Place batteries into trough according to figure.
4. Connect battery poles and enclosed connecting cables according to wiring diagram (Fig. 6/9). Provide for tight fitting and grease poles.

### 5.4.6 Disposal of Batteries

Used batteries labelled by the recycling sign contain re-usable substances. Such batteries must not be added to normal household waste. Obtain local information for the proper disposal of used batteries.

## 5.5 Solution tank

- 1 Solution tank
- 2 Marker
- 3 Fill level hose
- 4 Solution filter
- 5 Tank lid

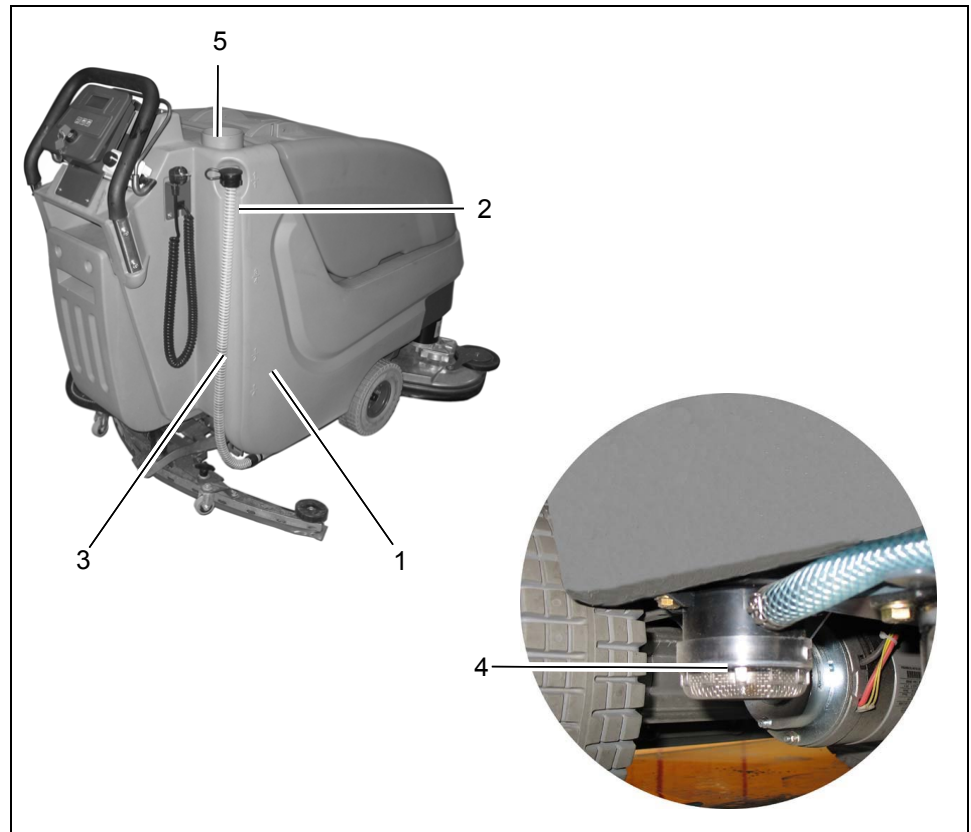

Fig.7

### 5.5.1 Fill solution tank

Fill solution tank (Fig. 7/1) before work or as required. Park vehicle on level ground. Open tank lid (Fig. 7/5) and fill tank up to the maximum (1/1 marker) (Fig. 7/2).

Alternatively, filling of the machine via quick coupling (Fig. 7/6) is available. Before doing so, connect the filling hose of the dosage unit and the quick coupling. The floater valve automatically closes after the maximum filling level has been attained.

(Refer to specific operating instructions for information on operation of the dosage unit)

The maximum admissible service pressure of the floater unit is 87psi.

### 5.5.2 Empty solution tank

Park vehicle such that the fill level hose (Fig. 7/3) is located above the drain aperture in the floor. Take fill level hose from holder and remove lid.

### 5.5.3 Solution Filter

Check solution filter (Fig. 7/4) at weekly intervals and clean or replace if required.

**NOTICE** Only clean solution filter when the solution tank is empty.

1. Empty solution tank (Fig. 7/1), see paragraph 5.5.2.
2. Unscrew filter cap.
3. Remove the filter element from the filter case for cleaning. Replace if required.
4. Re-install filter element and filter cap.

### 5.6 Recovery tank

- 1 Recovery tank
- 2 Drain hose
- 3 Suction filter
- 4 Tank lid

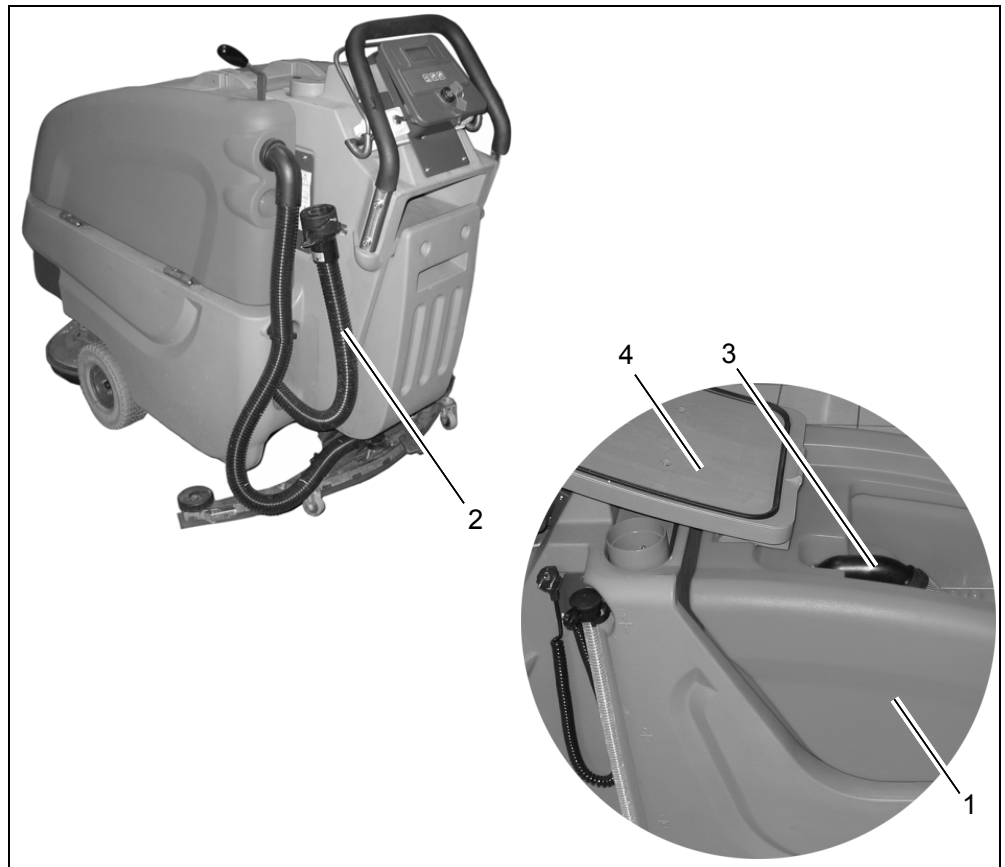

Fig.8

#### 5.6.1 Empty recovery tank

Clean recovery tank (Fig. 8/1) at daily intervals, as required or upon acoustic signal (increased vacuum motor speed).

1. Take machine to appropriate place for draining.
2. Park machine such that drain hose reaches a drain aperture in the floor.
3. Switch off machine.



Observe the legal provisions and the local regulations for disposal of detergents!

4. Take drain hose (Fig. 8/2) from holder and empty recovery tank completely.

#### 5.6.2 Clean recovery tank

Clean recovery tank (Fig. 8/1) at daily intervals or as required.

1. Empty recovery tank, see paragraph 5.6.1.
2. Open tank lid (Fig. 8/4) of the recovery tank.
3. Take drain hose (Fig. 8/2) from holder and empty recovery tank completely.
4. Remove remaining dirt by rinsing with clean water.
5. Rinse drain hose as well.

#### 5.6.3 Clean Suction Filter

Check suction filter (Fig. 8/3) for function at daily intervals and clean if required. The suction filter is clipped and can be easily removed.

## 5.7 Disc brush deck

- 1 Brush deck pedal
- 2 Brush deck
- 3 Brush ejectors
- 4 Roller bumper
- 5 Sealing strip

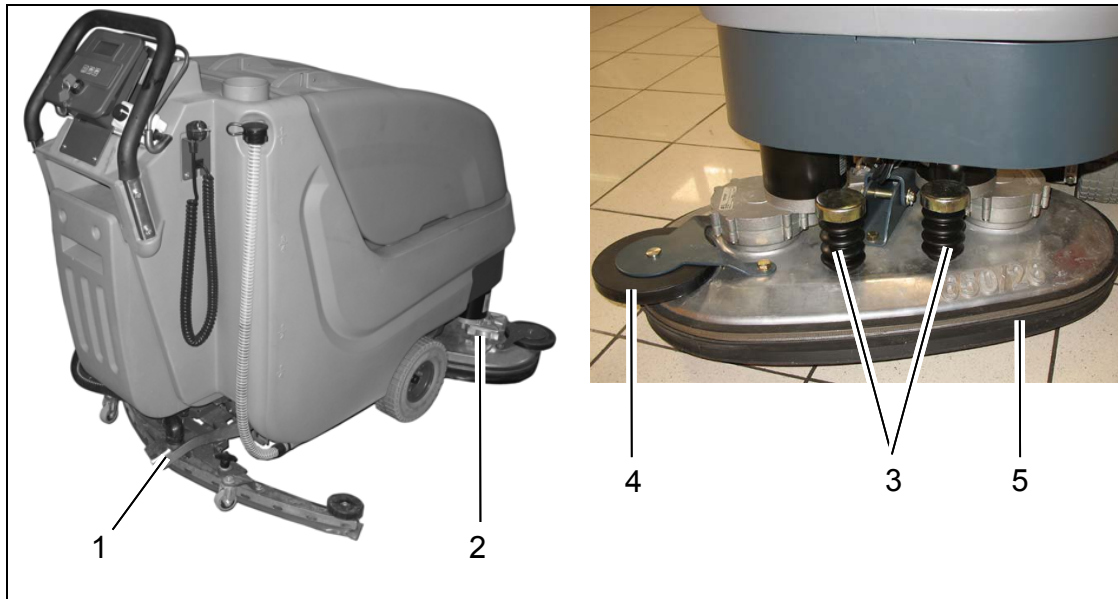

Fig.9

### 5.7.1 Clean Brushes

Clean brushes of the brush deck (Fig. 9/ 2) at daily intervals or as required.

1. Use pedal (Fig. 9/1) to lift up brush deck.
2. Press brush ejectors (Fig. 9/3) down to remove brushes for cleaning.

### 5.7.2 Change Brushes

Check brushes of the brush deck for wearing at weekly intervals. Replace brushes if bristles are worn down to a length of 5/8".

1. Use pedal (Fig. 9/1) to lift up brush deck.
2. Press brush ejectors (Fig. 9/3) down to remove old brushes.
3. Push new brush under brush deck and use both hands to press it into seating.

### 5.7.3 Change Roller Bumper

Check roller bumper(Fig. 9/4) at weekly intervals or replace as required.

### 5.7.4 Change Sealing Strip

Check sealing strip (Fig. 9/5) at weekly intervals or as required. Before doing so, open toggle-type fastener and remove sealing strip. Proceed to mounting in reverse order.

## 5.8 Squeegee

- 1 Squeegee
- 2 Star-shaped knob
- 3 Adjusting screw for angle adjustment
- 4 Suction hose
- 5 Fastening device
- 6 Washers for height adjustment

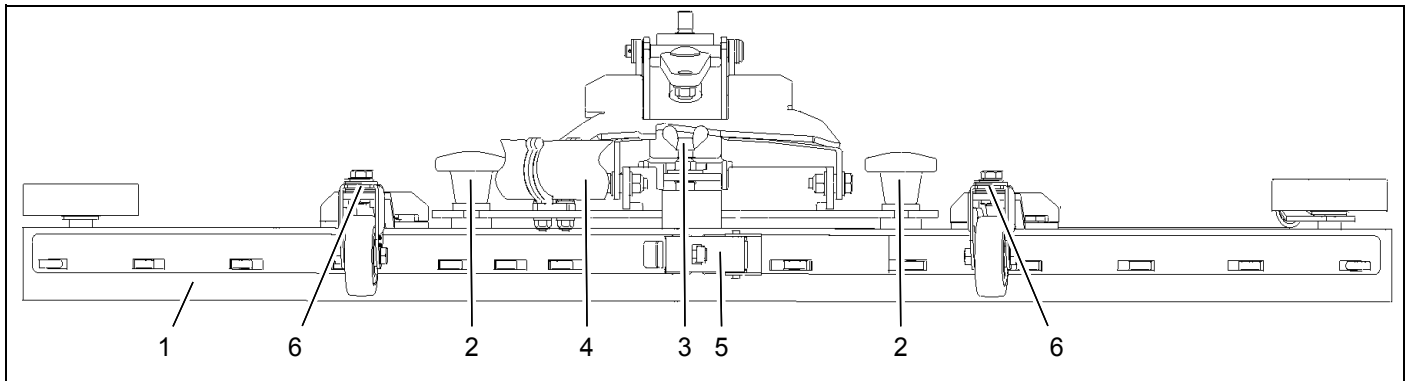

Fig.10

### 5.8.1 Cleaning the Squeegee

Check the squeegee (Fig. 10/1) daily and clean as necessary.

To clean it lift up the squeegee, pull off the suction hose (Fig. 10/4), loosen the two star-shaped knobs (Fig. 10/2) and remove the squeegee.

### 5.8.2 Change the Squeegee Blades

Check the inner and outer squeegee blades on the squeegee (Fig. 10/1) weekly for signs of wear. The squeegee blades can be used fourfold by turning them.

1. Lift the squeegee up.
2. remove the suction hose, loosen the two star-shaped knobs and remove the squeegee.
3. Unlock the fastening device (Fig. 10/5) and remove the outer squeegee blade. Turn the squeegee blade or install a new one. Change the inner squeegee blade in the same way.

## 5.8.3 Adjusting the Blades Angle Adjustment

The angle adjustment is the decisive factor in ensuring that the squeegee blades on the squeegee lie evenly on the floor.

1. Park the machine on a level surface and lower the squeegee.
2. Loosen the counternut on the adjusting screw (Fig. 10/3) and adjust the squeegee using the adjusting screw so that the ends of the squeegee blades have contact with the floor.

Figure A

Turn the adjusting screw counter-

clockwise: The clearance between squeegee blade and floor is reduced in the center.

Figure B

Turn the screw clockwise: The clearance between squeegee blade and floor is increased in the center.

3. Switch the machine on and check the suction pattern. When the machine is operating, the entire surface of the squeegee blades (center and outer areas) must be applied as evenly as possible.
4. Tighten the counternut on the adjusting screw at 5 lb ft.

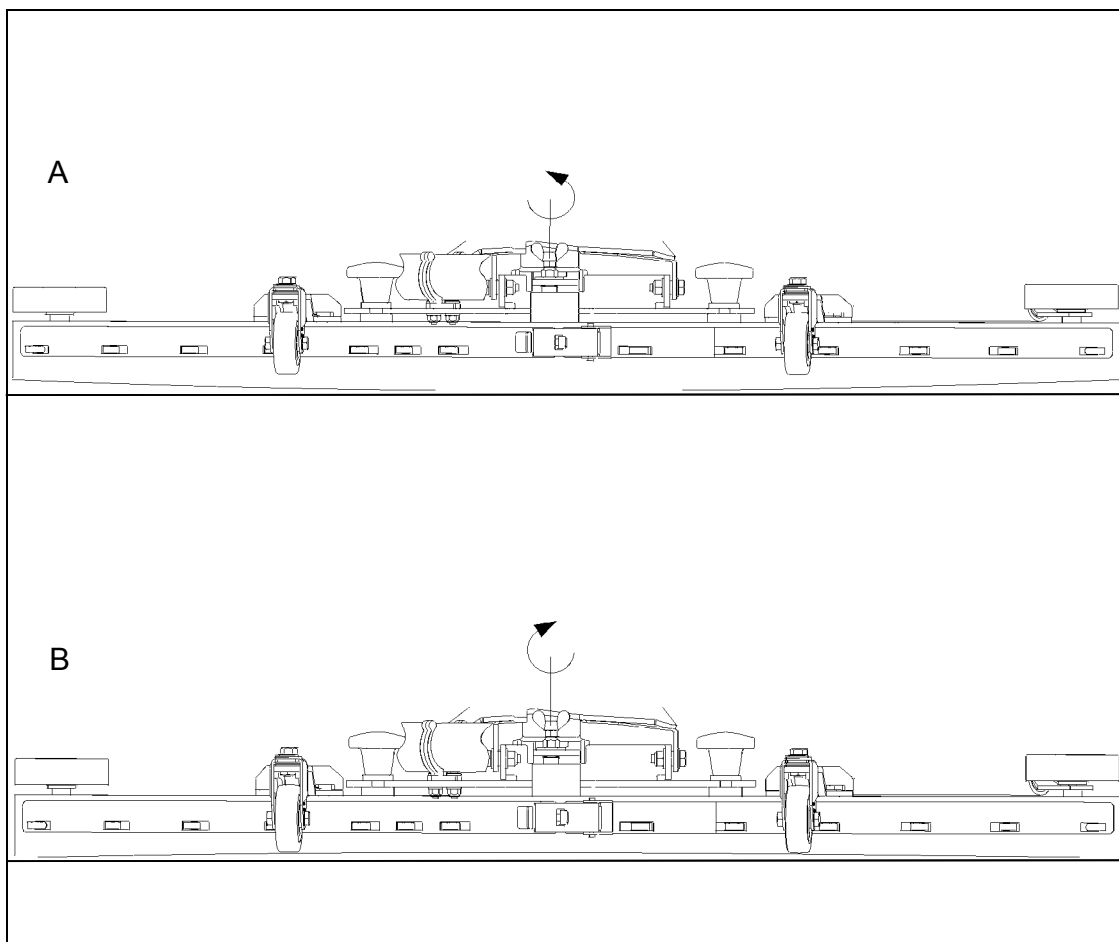

Fig.11



## Height Adjustment

The height adjustment is set to 3 mm at the factory. If streaks are produced, despite an optimum angle adjustment, the clearance between the casters and floor must be adjusted by changing the number of washers on the holder.

In cases of very smooth floors, e.g. finished floors, PVC, linoleum, etc. Number of washers = 2. This corresponds to a clearance of approx. 2 mm.

In cases of very uneven floors, e.g. poorly laid tiles (water does not run off) Number of washers = 4. This corresponds to a clearance of approx. 4 mm.



The Squeegee 110 cm (7569) is equipped with two additional rollers which are adjusted at the factory to a distance of 10 mm to the floor by means of spacers.

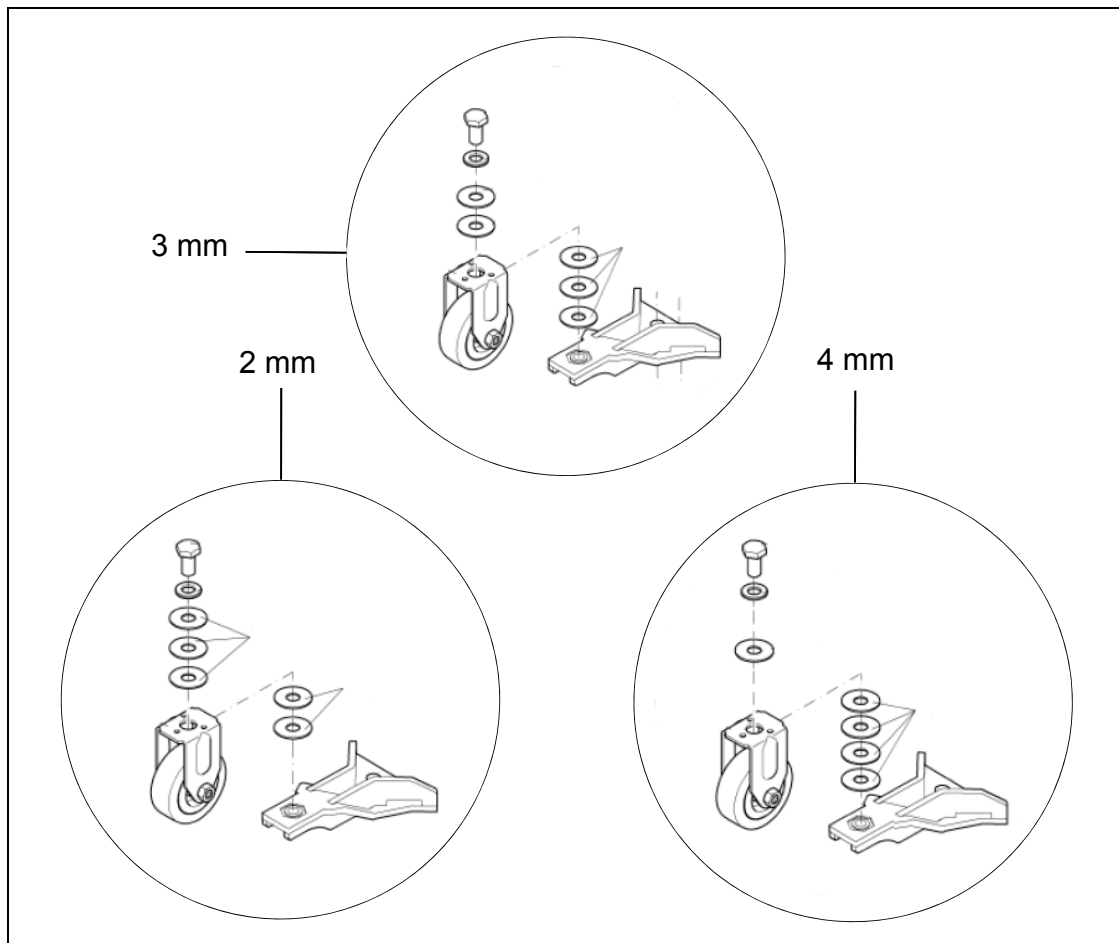

Fig.12



# HAMMERHEAD®



450**RS**



500**RS**



500**SS**



600**SS**



650**RS**



750**RS**



550**RDX**



650**RDX**



700**RSX**



750**RDX**



870**SR**

## HEADQUARTERS

4713 Old Gettysburg Road  
Mechanicsburg, PA 17055 USA

## CONTACT US

☎ 800.6.Bortek

☎ 717.737.7591

✉ [Orders@BortekIndustries.com](mailto:Orders@BortekIndustries.com)

🌐 [BortekIndustries.com/CUSTOMERLINK](http://BortekIndustries.com/CUSTOMERLINK)

**SWEEPERLAND.COM**

A complete family of  
power cleaning machines.