



 EQUIPMENT

 PARTS

 RENTALS

 SERVICE

 SUPPLIES



SERVICE MANUAL

CONTACT US

 800.6.Bortek

 717.737.7591

 Orders@BortekIndustries.com

 BortekIndustries.com/CUSTOMERLINK



HAMMERHEAD®

600SS & 650RS & 750RS



Table of Contents

1	Warnings	Page 3
2	General Information	Page 3
3	Maintenance Intervals	Page 4
	3.1 System Maintenance K (Customer)	Page 4
	3.2 System Maintenance I (125 hours of operation)	Page 5
	3.3 System Maintenance II (250 hours of operation)	Page 5
	3.4 Bortek System Maintenance S (500 hrs of operation, at least yearly)	Page 6
4	Squeegee Cable and Recovery Tank Gasket	Page 6
	4.1 Squeegee Adjustment (First Version)	Page 7
	4.2 Squeegee Adjustment (new Style)	Page 7
	4.3 Squeegee Lift Cable, Micro Switch, Vacuum Motor	Page 9
	4.4 Squeegee Wheel Adjustment	Page 8
5	Brush Head (Disk Brushes) Connections	Page 9
	5.1 Brush Motor Information	Page 10
6	Brush Head Transport Position	Page 10
	6.1 Brush Switch	Page 11
	6.2 Brush Pressure Adjustment on the Disk Models	Page 11
	6.3 Brush Pressure (Disk Decks)	Page 12
	6.4 Cylindrical Brush Head Electrical Connections	Page 12
	6.5 Cylindrical Brush Head Adjustment	Page 13
7	Drive and Wheels - General Data	Page 13
	7.1 Electric Brake	Page 13
	7.2 Transaxle Motor	Page 13
	7.3 Carbon Brushes	Page 14
	7.4 Drive Potentiometer	Page 14
8	Water Supply	Page 15
	8.1 Solenoid	Page 15
	8.2 Solution Filter	Page 15
	8.4 Solution Flow Rates	Page 15
	8.5 Water Pump	Page 16
9	The Last Error	Page 16
10	Table of Error Codes and Information	Page 17
11	Battery Charger	Page 18
	11.1 Operating Instructions	Page 18
	11.2 Charger Error Codes	Page 19
	11.3 Charger Trouble Shooting	Page 20
	11.4 Charger Maintenance Points	Page 20
	11.5 Programming The Charger	Page 21
	11.6 Replacing The Charger Harness	Page 23
12	Batteries	Page 23
	12.1 Maintaining Wet Lead Acid Batteries	Page 23
	12.2 Load Testing Batteries	Page 24
	12.3 Hydrometer Testing	Page 24
13	Fuse Locations Version 2	Page 25
	13.1 Controller Version 3	Page 26
14	Controller Connections	Page 27
15	Trouble Shooting Controller	Page 27
16	Contactors Harness	Page 28
17	Contactors Wiring	Page 29

1. Warnings

- Disconnect the A.C. Cord from the outlet and and D.C. Cord from the battery pack before servicing the machine. Except for making voltage and current measurements.
- Before replacing the main fuses, only loosen the nuts. Do not remove them completely. Failure to do so could cause a short circuit.
- Place the new stripe fuse fully and evenly under the nuts and washers and make sure not to twist the end tabs, they can easily be torn.
- After any repair work is done, test the machine for proper operation.
- When servicing the machine always observe the general safety and accident prevention guidelines.

2. General Information

•The display offers a service indication. Upon turning on the key switch, a four digit number describing the software version (e.g. 1.0.0.2) appears for about 3 seconds, followed by another 4-digit code indicating the last error recorded, then followed by the hour meter.

•If a failure occurs, the code appears in the control panel and an acoustic signal sounds. The current error code appears as 4-digit alpha-numerical code with flashing dots in the service display. Only if these criteria are met, the error is a current one!

The error codes are listed in a tables in chapter 10.

•When raising the machine with a car jack, use the area of the frame in front of the caster wheels on the left or the right.



3. Maintenance Intervals

In a modular structure, the System Maintenance determines the specific technical procedures to be performed and sets the time interval between the two maintenance cycles. For each of the maintenance cycle, the replaceable parts are determined as well. Further details described in the specific chapters.

•System Maintenance K:

To be performed by the customer (in daily or weekly intervals) according to the maintenance and care instructions as specified in the operating instructions.

The operator must be professionally instructed after delivery of the machine by selling dealer.

•System Maintenance I: (after every 125 hours of operation)

To be performed by an authorized Service Center in accordance with the machine-specific system maintenance.

•System Maintenance II: (after every 250 hours of operation)

To be performed by an authorized Service Center in accordance with the machine-specific system maintenance.

•System Maintenance S: (after every 500 hours of operation, safety check) To be performed by an authorized Service Center in accordance with the machine-specific system maintenance.

3.1 System Maintenance K

To be performed by the customer/user	Interval	
	Daily	Weekly
Fill the clean water tank and mix the proper amount and type of cleaning solution.	O	
Charge the batteries.	O	
Check the brush head, Clean if needed with a damp cloth. Do not get water inside the motor.	O	
Check the squeegee, clean if needed	O	
Check the lid gasket on the recovery tank.	O	
Empty and flush the recovery tank with clean water.	O	
Clean the filter/float inside the recovery tank.	O	
Check the water levels of all the batteries. Add distilled water, if needed. Do not over fill.	O	
Check the pads and brushes for wear. Replace if needed.		O
Check the squeegee hose for clogs, damage and wear. Replace if needed		O
Check the squeegee rubbers for cuts and wear. Flip the blade(s) over or replace.		O
Check the solution filter. Clean if needed.		O
Flush the clean water solution tank with warm water.		O
Test all the functions of the machine.		O

3.2 System Maintenance I

To be performed by the authorized service center	Interval
	Every 125 hours of operation
Check the battery charger. Make sure it is functioning properly	O
Check the recovery lid gasket. Replace if needed	O
Lubricate the brush lift linkages with grease. Use a small brush.	O
Check for loose hardware, tighten if needed.	O
Check the tire pressure on pneumatic wheels at 65 PSI, if equipped.	O
Lubricate the squeegee linkages with grease. Use a small brush.	O
Inspect the entire machine for damage, wear and proper operation.	O

3.3 System Maintenance II

To be performed by the authorized service center	Interval
	Every 250 hours of operation
Inspect the caster wheels for wear and damage. Repair, if needed.	O
Inspect the carbon brushes for wear in the transaxle. Replace, if needed.	O
Inspect the recovery drain hose for wear or damage. Replace, if needed.	O
Inspect the brush bumper rollers for wear or damage. Replace, if needed.	O
Inspect the carbon brushes for wear in the brush motors for wear. Blow out with compressed air.	O
Inspect the recovery hose for damage or wear. Replace, if needed.	O
Inspect the squeegee assembly for proper adjustment. Repair, if needed.	O
Test the machine for proper operation.	O

3.4 System Maintenance S (Safety Check)

To be performed by the authorized service center	Interval
	Every 500 hours of operation
Replace the carbon brushes in the transaxle.	O
Replace the carbon brushes in the brush motors.	O
Test the machine for proper operation.	O

4. Squeegee Cable And Gasket

4. The squeegee cable is attached to the lift lever (top) via a spring (Fig. 5/5). The bottom is attached to the eyebolt at the squeegee mechanism (Fig. 5/6). The squeegee lift cable can be accessed after opening the electronic module cover at the rear of the machine.

The vacuum motor is connected to the A1 at A1.X34:5+6 on the controller. Current consumption of the vacuum motor amounts to approx. 25A max.

The vacuum water lift in the closed tank is at least 65 inches (150mbar).

Recovery Lid Gasket

Insert the recovery tank cover gasket (Fig. 5/7) so that the seam is positioned at the front center with a gap of approx. 1mm. The dirty drip water on the top sealing surface will be drawn into the recovery water tank.



Fig. 5/5

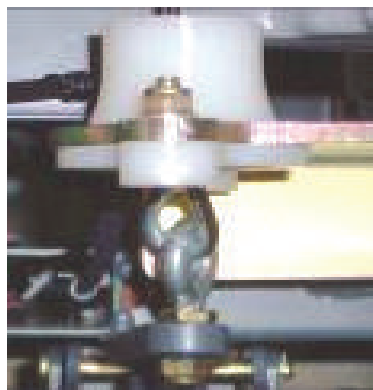

Fig. 5/6

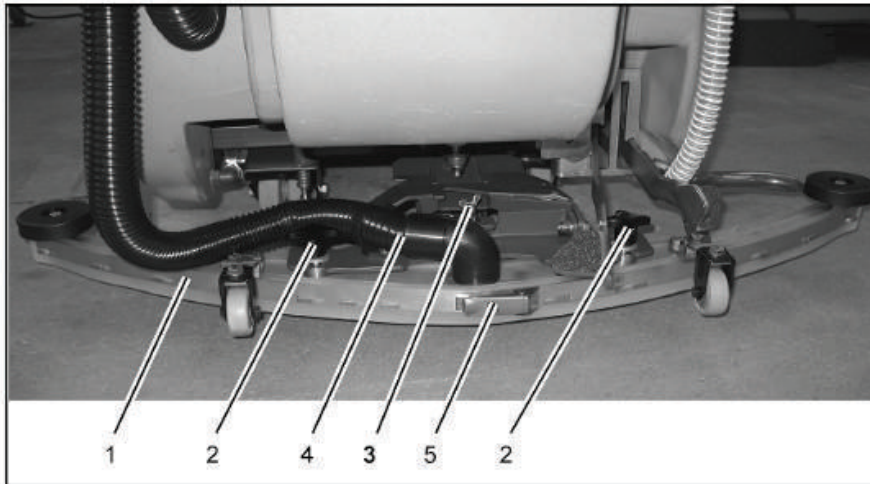

Fig. 5/7

4.1 Squeegee Adjustment ----Version one

Correct squeegee adjustment is prerequisite for optimal suction results. Before adjustment first check the pitch of the squeegee and re-adjust if required.

1. Place machine on level ground.
2. Loosen nut of the adjustment screw (pos. 3, Fig. 5/1) and adjust sealing strips in parallel to the floor. Turn adjustment screw clockwise: clearance between squeegee blade and floor broadens in the center. Turn adjustment screw counter-clockwise: clearance between squeegee blade and floor narrows in the center.
3. Turn machine on, lower squeegee and check drying pattern.



- 1 Squeegee
- 2 Star-shaped knob
- 3 Adjustment screw
- 4 Suction hose
- 5 Toggle-type fastener

Fig. 5/1

4.2 Squeegee Adjustment ----Version Two

Correct squeegee adjustment is prerequisite for optimal suction results. Before adjustment first check the pitch of the squeegee and re-adjust if required.

1. Place machine on level ground.
2. Loosen the two bolts, located on each side (Fig 5/2A) with the squeegee attached while holding another wrench on the location shown on Fig 5/2B. Adjust squeegee rubbers so that they are parallel to the floor, by turning the long adjustment shaft on the right side with an open end or adjustable wrench (Fig 5/2B). Adjust until the rear squeegee blade folds equally across the entire length, while moving the machine slightly forward.
3. Tighten the two bolts on the ends while holding the center shaft with the wrench.
4. Turn machine on, lower squeegee and check drying pattern.

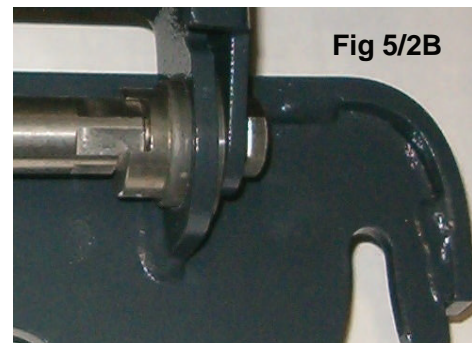
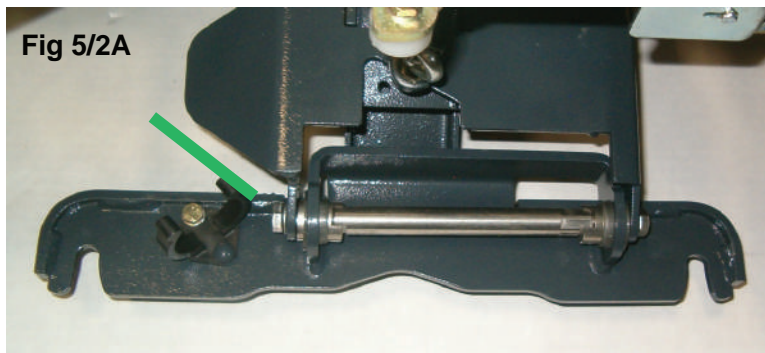

4.3 Squeegee Wheel Adjustment

4.3 The clearance between the support roller and floor with squeegee unfolded (Factory setting) is: 0.1181099 Inches \pm 0.01968498 inches (3 mm \pm 0.5).

Note: Some floor surfaces may require adjusting the caster washers for optimum performance.

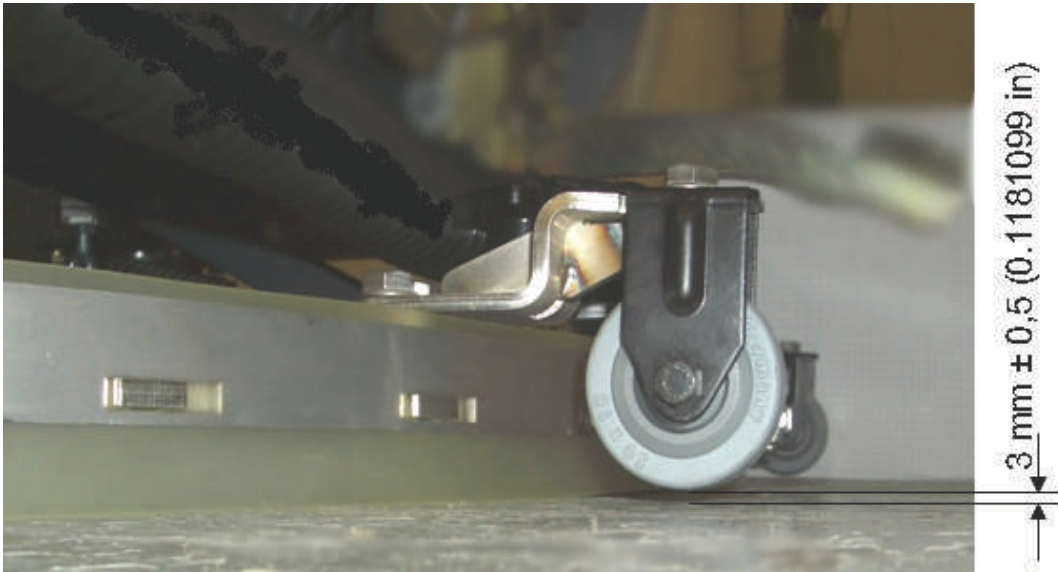

4.4 Squeegee Wheel Adjustment

4.4 Note: When adjusting the wheel height, there should always be 5 washers on each wheel assembly position # 15 in order fully tighten bolts. Move washers from the top to the bottom of the bracket or visa versa when making adjustments. The caster controls the pressure on the squeegee blade.

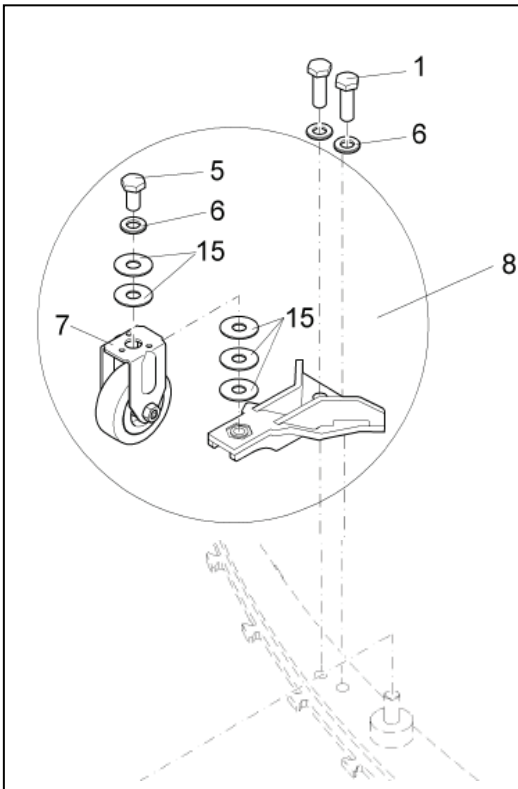

Pos 1 – Hexagon screw M8x25 A2
PN 01059530

Pos 5 – Hexagon screw M8x16 A2
PN 01071740

Pos 6 – Washer B8,4
PN 00101550

Pos 7 – fixed Roller
PN 01077810

Pos 8 – Angle with fixed roller, complet
PN 01079070

Pos 15 – Distance Washer
PN 01079080

Fig. 5/3

4.5 Squeegee Lift Cable, Switch & Motor

Squeegee Lift Cable, Lever, Micro Switch and Vacuum Motor

- The vacuum motor **micro switch** is mounted behind the squeegee lift lever (Fig. 5/4). Adjust the micro switch so that the vacuum motor can be turned off by lifting the squeegee by the lever. Loosen the screws on the switch to adjust.
- Vacuum motor is switched on upon lowering of the squeegee.
- The micro switch is a *normally open* switch which is terminated to input A1.X9:3+9 on the controller. When the squeegee is lowered, there should be continuity between both contacts (with the plug A1.X9 being disconnected).



Fig. 5/4

NOTE: The squeegee lift cable spring will need to be disconnected from the silver lever before the squeegee lift lever plate can be removed from the machine. Access can be made from the controller/charger area in the rear of the machine. See Chapter 4.

5. Brush Head (Disk) Connections

Connection of Brush Motors to Disk Brush Head

Connect the brush motors of the disk brush head in accordance with the electric diagrams. Find the assignment of connecting stud of the motors listed in the below table. Then check the correct direction of brush motor rotation.

The left-hand motor seen in direction of travel is M3, the right-hand one is M4.

Cable Harness	Motor connection Disk brush	Connectors at the motor -M3/4
-M3:1	-M3:N	Stud bolt above Connection N
-M3:2	-M3:P	Stud bolt below Connection P
-M4:1	-M4:P	
-M4:2	-M4:N	

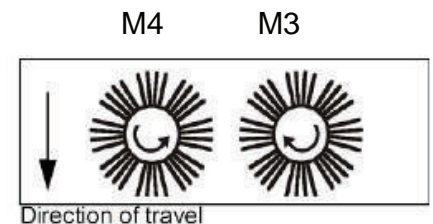

5.1 Brush Motor Information

The brush motors are switched on and off by a micro-switch located at the rear at the brush head lift-out system. This switch is realised as NO (normally open) switch. To attain safe function of the brush motors, correct adjustment of this switch is required.

Electric connection of the switch is realised at the central control at A1.X9:4 + 10.

Maximum current consumption of the brush motors (in practical use) must not exceed 30A per motor on the 26 and 30" disk brush decks.

Lower settings are recommended for longer motor life, run time and traction.

When checking the carbon brushes make sure that the scroll spring is pressing the carbon brush against the commutator, does not contact the guide and that distance to carbon brush guide is sufficient.

Replace the carbon brushes, if required.

6. Brush Head Transport Position

- The lever provided is for lifting up the brush head. It features 3 positions for adjusting the lift linkage (Fig. 6/1). The top hole is the transporting and ramp climbing position. In this position, the lift linkage is to be adjusted so that a 1mm gap appears between the lever and the screw head at the chassis (Fig. 6/2).

- The middle hole position is for scrubbing with pads.

- The bottom hole (Fig. 6/1) is the normal scrubbing position of the brush head.

Transport Position

Scrubbing position
with pads

Scrubbing position
with brushes



Fig. 6/1

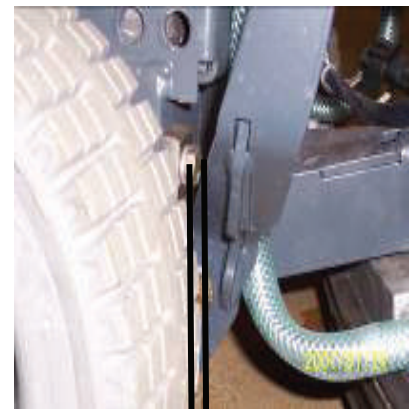

1 mm

Fig. 6/2

6.1 Brush Switch

- The brush motors are switched on and off by a micro-switch located at the rear at the brush head lift-out system Figure 6/3. This switch is a NO (normally open) switch. To attain safe function of the brush motors, the correct adjustment of this switch is required.
- Electric connection of the switch is connected to the central control circuit board at A1.X9:4 + 10 connector. In the lifted-up position, the switch should open and close when brush head is lowered.

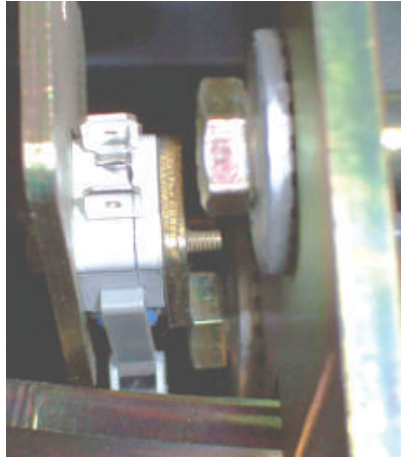
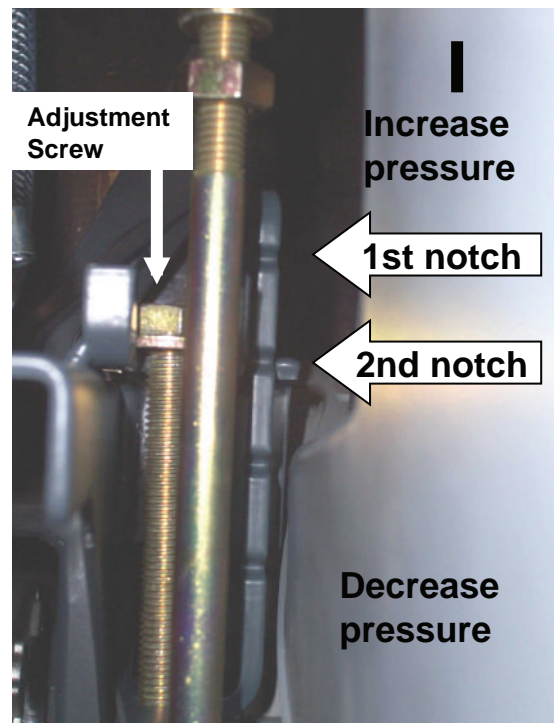

Fig. 6/3

6.2 Brush Pressure Adjustment (Disk Models)

- The bolt on the left can be adjusted to increase or decrease the brush pressure.
- Models with 19 gallon tanks** This pressure adjustment will affect the models in the normal scrubbing mode. (no extra pressure option)
- The indicator on the right should never be set past the second notch.
- NOTE:** When making changes, the current draw should be less than 30 amps. per motor on the 26 and 30" disk decks under load maximum.
- Lower settings are recommended for longer motor life, longer run time and traction.
- Verify the current with brushes under load, with a digital clamp-on meter.
- Only an authorized Service Center should make changes to the brush pressure setting.



Note: The factory setting set at the second notch

6.3 Brush Pressure

Model	Area Per Brush	Brush Pressure	Heavy Brush Pressure (2nd Foot Pedal Engaged)	Specific Surface Pressure	Specific Surface Pressure with Heavy Brush Pressure
24	240 cm ² 37.200 inch ²	260 N = 58 lb	NA	0.54 N/cm ² = .783 lbs per inch ²	NA
26	586.5 cm ² 90.908 inch ²	350 N = 79 lb	NA	0.3 N/cm ² = .435 lbs per inch ²	NA

6.4 Brush Head (Cylindrical)

Electric Connections

- Connect the brush motors of the cylindrical broom head in accordance with the electric diagrams. Find the assignment of connecting stud of the motors listed in the below table. Then check the correct direction of brush motor rotation.
- The left-hand motor seen in direction of travel is M3, the right-hand one is M4.

Cable Harness	Motor connection Cyl. brush head	Connectors at the motor -M3/4
-M3:1	-M3:N	Stud bolt above Connection N
-M3:2	-M3:P	Stud bolt below Connection P
-M4:1	-M4:P	
-M4:2	-M4:N	

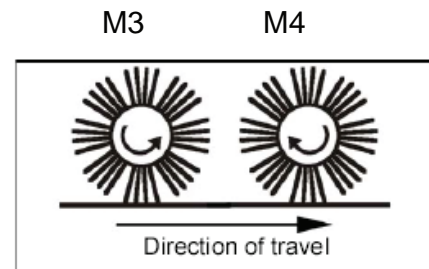

6.5 Adjusting Cylindrical Deck 24 and 28" only

Adjust Brush Head

Prerequisites:

- Cylindrical broom head is mounted to the machine
- Machine is equipped with batteries
- Spacer blocks are positioned under the lateral lids

Use adjustment screw (Fig. 5/1) for brush head adjustment. Use a reference gauge (Fig. 5/2) to check the dimension.

1. Position the reference gauge straight between guide (Fig. 5/3) and washer (Fig. 5/4) onto the slider (Fig. 5/5).
2. Ideal adjustment is attained if the central edge (Fig. 5/A) of the reference gauge is flush with the top edge of the guide. If required, modify adjustment such that the upper edge of the guide on both sides does not exceed the + edge and does not fall below the - edge.
3. Counter-lock adjustment screw by nut.

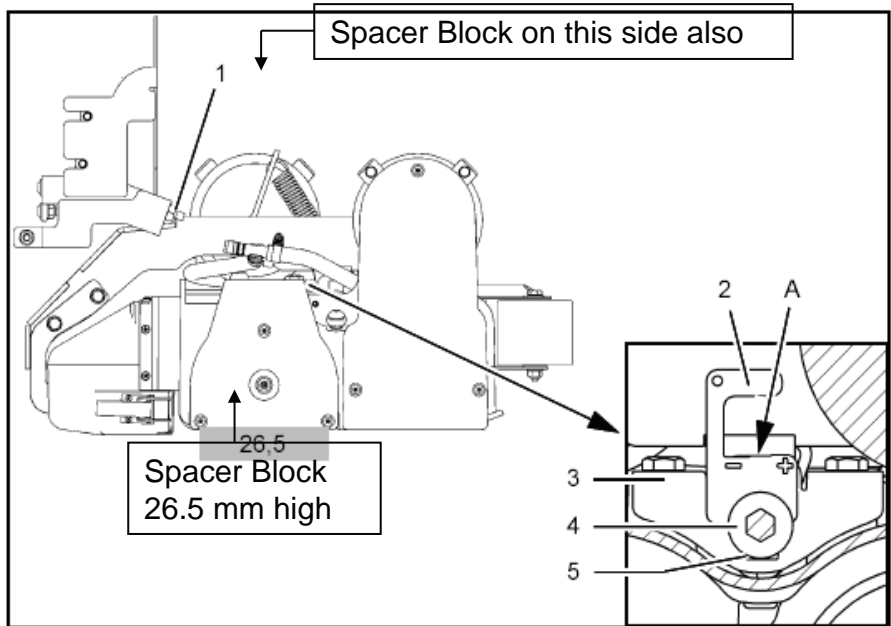

Fig.5

Part number for the gauges are available by request.

7. Drive and Wheels

General Data-

Torque of wheel bolts:	23 foot lbs
Torque of wheel nuts:	18 foot lbs
Wheel speed in max. drive potentiometer position:	
Forward: (3.1 mph) 110 min ⁻¹	Reverse: (1.55 mph) 55 min ⁻¹
Torque of setting for screws on caster mounting:	17 foot lbs

7.2 Transaxle Motor

- Drive motor, axle and differential are a single unit.
- The wheel drive is nearly maintenance-free. Check the carbon brushes of the drive motor at regular intervals during maintenance. Carbon brushes are worn if the scroll spring applying the carbon brushes to the armature, is approx. 1mm away from the guide. Contact of the spring and the guide must be avoided since otherwise the armature can be damaged. Before the check, remove battery and battery tray from the machine.

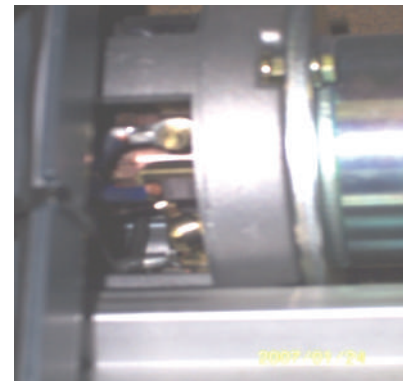

- The thermal switch of the drive motor is integrated in the motor and cannot be replaced. Such switches are NC (normally closed) switches which interrupt the circuit, if the motor temperature exceeds the limit. The thermal switch is connected to the control board at A1.X9:2+8.

7.3 Carbon Brushes

Close the cover of carbon brushes again as shown in photos 7/2, 7/3 and 7/4. Make sure that the plastic lock is placed in a motor housing recess for brushes.



Fig. 7/2



Fig. 7/3



Fig. 7/4

7.4 Drive Potentiometer Circuit

•Potentiometer Resistance

Value: 5.875 k Ω +- 30%

•Assignment of connecting plug (A1.X4):

- Pin 1: Ground
- Pin 2: 24Volts
- Pin 3: Digital signal of drive direction 1
- Pin 4: Digital signal of drive direction 2
- Pin 5: Potentiometer wiper
- Pin 6: Potentiometer +
- Pin 7: Potentiometer -
- Pin 8: not assigned

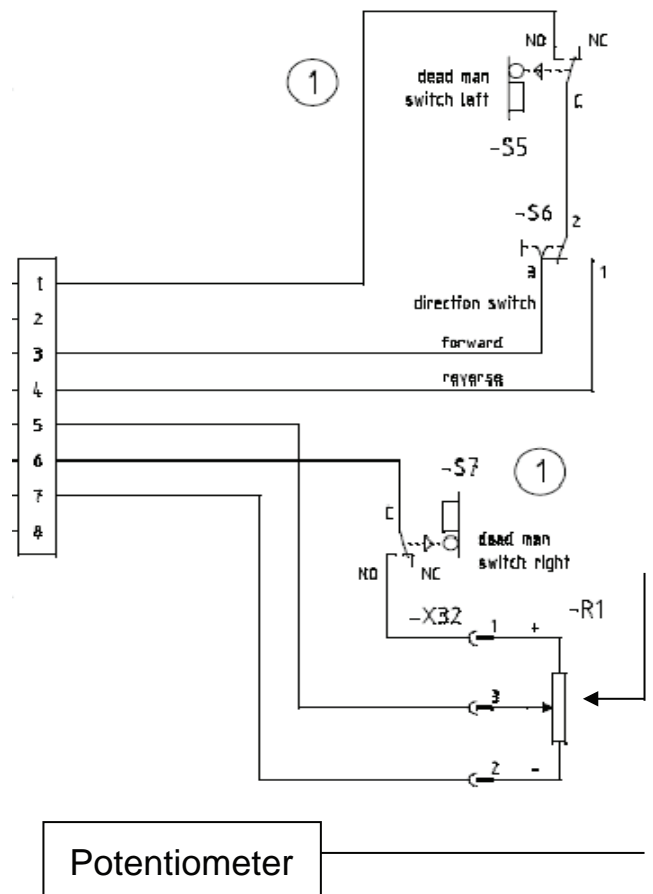

8. Water Supply

8.1 The **solenoid** valve releases or stops supply of water flowing to the brushes. The solenoid valve is located at the front pane of the battery compartment. The solenoid valve is electrically connected to the central controller A1 at A1.X11:1+2. See Fig. 8/1

- Coil resistance of solenoid: approx. 47 Ω
- Current consumption of solenoid: approx. 0.5 A
- Water amount is regulated by ball valve on all the 19 gallon and models.



Fig. 8/1

8.2 Solution Filter

The clear water supply line to the brushes is equipped with a filter screen. In case of problems with the supplied water amount, check the screen and the hoses from clear water tank and to the brushes. See Fig.8/2



Fig. 8/2

8.4 Solution Flow rates

Water Setting		1	2	3	4	5	6
Disk Brush 30"	Gallons per min	.18	.29	.36	.52	.95	1.45
	Pump Voltage	2.68	3.46	4.61	5.84	9.82	15.43
Cyl. Brush 24"	Gallons per min	.39	.47	.55	.60	.68	.74
	Pump Voltage	4.69	5.99	6.85	7.47	8.45	9.24

Note: Values are proportional to the drive speed

This information applies to models equipped with a solution pump only.

The 26" model is manually controlled by the operator.

8.5 Water Pump

Solution Control

- Models equipped with water pump
 - The solution flow rate is affected by the speed of the drive system.
 - The controller adjusts the voltage to the pump to regulate water volume.
 - The faster the machine is driven the more water will flow to the brushes.
 - The controller uses stand still recognition circuitry. The pump will be shut off, if the water supplied to the pump is too low or inefficient, when the voltage supplied to the pump is above the 5 volt level. This feature is disabled if voltage is below 5 volts.
-

9. The Last Error

- **All models are equipped with an error memory which will indicate the last error that occurred in the machine. This last error is displayed upon turning on the machine by key switch. The first numbers that appear will be the software version. The second will be the last error (if one had occurred). The third will be the hour meter.**
- **If four digit error code is displayed continuously with blinking dots and the alarm is sounding, the controller has detected a problem in the system. The machine will be inoperable. See error codes for details.**

10. Table of Error Codes

Error code	Error source	Remarks
1.2.5.2.	Thermal switch Brush 1/2	Check temperature of brush motors; check current consumption of brush motors; check wiring of thermal switch (X8 and X9 plugs) of the brush motors (series connection). Input A1.X9:1 and 7
1.2.6.1.	Blocking protection Brush 1/2 Electronic protection of brush motors	Brush motors smooth running? Check current consumption? 30A max. per motor
3.1.6.E.	Fuses of power unit	Group message all fuses on the A1
3.2.1.1.	LDS defective	Is battery voltage identical to voltage at A1:X1 and A1.X2? (idle run and under load)
3.4.1.1.	Drive rheostat	Check drive rheostat and wiring, is drive rheostat mechanically in central position?
3.4.1.2.	Drive control defective	If error is permanent, replace central controller
3.4.5.1.	Drive motor overheated	Check thermal switch and wiring from drive motor, X10 plug

Error code	Error source	Remarks
4.5.2.5.	Control panel not recognized	Check connecting cable between central controller and control panel. This error occurs upon switching on only.
4.5.3.5.	No response control panel (Timeout)	Check connecting cable between central controller and control panel. This error occurs upon switching on only.
4.6.1.2.	Internal controller error	If error is permanent and even after repeated switching on and off of the machine, replace central controller
5.1.4.1.	Main contactor does not switch	Does main contactor K1 switch? Check main contactor wiring. Contacts
5.4.6.1.	Error upon system start (signal states)	If error is permanent and even after repeated switching on and off of the machine, replace central controller
"H"	Hand emergency release	See chapter 7.1 Magnet brake at drive motor

11. 24V - 22A Charger

10.1 Operating Instructions

Controlled battery charger for lead batteries with liquid and solid electrolyte in SNT technology

controlled backup charging - reverse battery protection
protection against short circuit - const. conservation of charge
low AC-current

General

The battery charger is designed for automatic charging of single cell sulphuric acid batteries (12 cells) according to batterytype, capacity and initial charging current indicated on the name plate. The charging is done as per the IEB (di/dt - du/dt) characteristic curve. It is controlled and switched off by a electronic controlled charging switch device.

The housing of the battery charger is made of enclosed sheet metal steel.

Connection to wall outlet (plug socket) is made via an incorporated mains connection cable.

Mains fuse (F1): Micro fuse 5x20 mm. Back-up only through valueresembles T 3,15 AH 250V.

The battery charger has to be connected to mains supply with a earthing contact outlet; it should be made safe by means of a 16 ampere inert fuse.

The battery charger is protected against short circuits and equipped with a reverse battery protection.

The battery charger should only be opened by qualified personnel.

Attention: Non-rechargeable batteries can not be charged with this battery charger.

The battery charger complies with the protection regulations of the low voltage guideline 72/23/EEC and the guideline for electro-magnetic compatibility 89/336/EEC



EN 60 335-1
EN 60 335-2-29

11.1 24V - 22A Charger

Installation

Keep the charger away from other heat radiating devices.

The cooling system of the housing ensures better heat dissipation for the components and must not be covered. Use the battery charger in a dry and well-ventilated area.

Sequence of connection:

The charger has to be disconnected form the mains supply before connecting/ disconnecting the charge plug/ cables to the battery.

Functional description and monitoring of charging process

The battery charger begins charging automatically, if the mains power and the battery connection has been properly connected.

With load beginning the battery connection is checked, all LED ´s light up briefly.

The lower charge icon  lights up.

When the preset gassing voltage has been reached this voltage is stabilized and the current drops slowly (U constant). After the current has reached a constant phase, the charger switches over to backup charging

and the middle and lower charge icon  lights up.

After the backup charge has been completed the charging electronic switch device changes to end of charging/const. conservation of charge. All three charge icons  lights up.

Do not interrupt the charging procedure until battery is adequately charged. An interruption may cause a loss of capacity and premature failure of the battery.

The driving-off protection is a potential-free contact preventing the use of the vehicle during the charging process.



„Battery not connected“ is indicated by the red LED and is detected immediately when switching on the battery charger during operatin; at the latest 20 secs. after disconnection of the battery.

Please make sure that there is no reverse connection of the battery during this time!

When the battery is connected again, the charging set switches itself on.

11.1 24V - 22A Charger

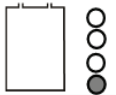
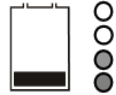
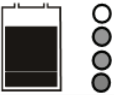
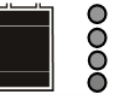
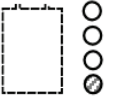
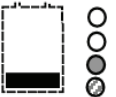
Indication of operating status by external Display

operating status	LCD-/ LED- Indicator				
					
Main charging $U_{bat} < 1,9V/Z$	X				
Main charging		X			
Backup charging			X		
Conservation charging				X	
operating status during malfunction*					malfunction number
Battery malfunction	X				1..2
Time malfunction		X			3..4
Control malfunction			X		11..13
Temperature malfunction				X	6

* If there is a malfunction the frame/under LED flashes once a second.

11.2 Charger Error Codes

Note: The following are error indicators that could occur during the battery charging process. All errors will be in the form of a blinking display picture of the battery.

The display indicator figure # 1 will display a blinking dotted square, if the battery malfunctions for the following reasons:

1. The battery has less than 1.25 volts per cell.
2. The battery has less than 15 volts after 30 minutes
3. The batteries are wired incorrectly (reversed polarity).
4. The batteries are missing.
5. The wrong battery type is installed.
6. The selected programming of the charger is incorrect for the batteries that are installed.

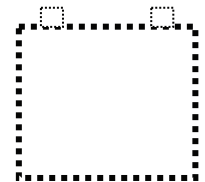

Fig.1

The display indicator figure # 2 will blink, when the charger timer times out. This occurs when the battery voltage on a 24 volt battery pack does not reach 22.8 volts or higher after 30 minutes. The charger will shut off.

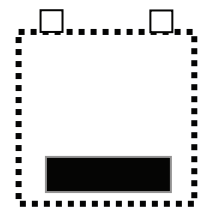

Fig. 2

The display indicator figure # 3 indicates that there is an error in the charger.

- 1.The charger needs repair or replacing.

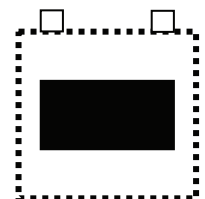

Fig. 3

11.2 Charger Error Codes

The display indicator figure # 4 will blink when the charger is over heating:

1. The cooling air is restricted
2. The cooling fan is not working.
3. The cooling hose is not connected or is obstructed.

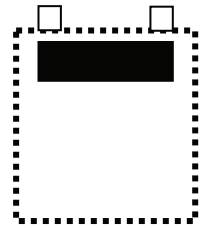

Fig. 4

Programming button depressed while starting the charging operation.

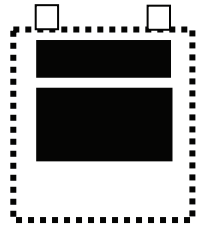

Fig. 5

11.3 Trouble Shooting the Charger

- Symptom - charger has no output.

Check for loose or burnt connections on the side of the charger.

- Use a test cord by-pass the original AC power cord.

Note: Continuity and voltage tests may not be adequate for testing the condition of the AC cord.

- Power cords from a desk top computer will make a good test cord.

11.4 24V - 14A Charger

Charger Maintenance Points

- Check the following, when servicing the machine:
 - The charger unit should be secured by rubber strap.
 - The wires going to and from the charger should be secured with plastic wire ties. They should be routed so that there are not any kinks, pinched or crushed wires.
 - The charger housing must be insulated from all metallic machine parts. Use a multi-meter to measure the resistance between charger housing and the frame on the machine. There should not be continuity.
 - Repeat the test by checking the resistance between the A.C. Cord ground pin of the charger and frame of the machine. There should not be continuity.
 - The ground pin of the A.C. cord must conduct without resistance to the screws on the charger case.
 - The charger ventilation hose must in place and without obstruction.

11.5 Programming the Charger

The automatic scrubbers are equipped with the new on board automatic charger. The charger will be programmed from the factory for the wet lead acid batteries. Machines that were purchased with gel maintenance free batteries installed at the factory will be programmed for gel.

1. The charger can be programmed to charge either the gel type battery or wet lead acid batteries.
2. Follow the instructions below to change the charging mode.
3. Remove the two Allen head screws on the rear of the machine. Let the charger/controller-cover drop down. The charger is located on the rear of the housing.
4. Remove the nut and washer on the backside. Carefully lift the plastic cover off and set it to the side.
5. Plug the charger's A.C. power cord into the outlet. The charger will turn on.
6. Locate the small push button switch on the right side of the charger. Located near the rubber strap.

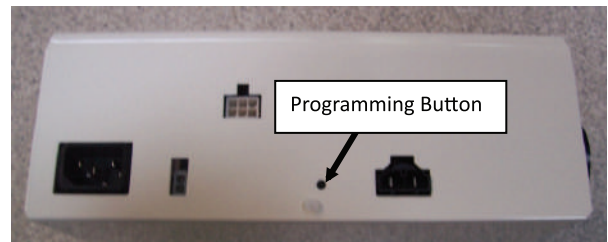
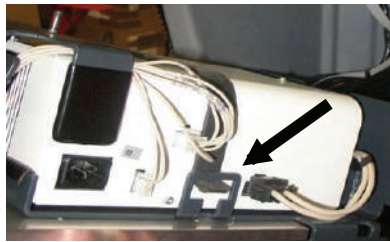

7. Push and hold the button in for 2 to 4 seconds and release. The charger will turn off.
8. Push and hold the button in again for >10 seconds and release. This puts the charger into the programming mode. The picture on the machine's display will blink rapidly indicating which charging mode has been previously stored in the charger.
9. Push the button for <1 (one) second at a time to select a different charging mode. The picture will blink slowly, indicating that you're in the selection mode. Push the switch repeatedly until the desired mode is displayed.
10. The charger will show a total of 8 (eight) different charging modes. (See pictures below for the proper mode). The remaining settings do not have any additional functions.

11.5 Programming the Charger Cont.

Mode # 0 is for the Trojan # 956752 260 Ah batteries for the charger 96137732 only.

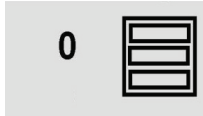

Mode # 1 is for AGM batteries 956749 (260 Ah) & 956200 (200 Ah) for the charger 96137732 only.



Mode # 5 is for gel type batteries using chargers prior to charger serial 96117197 7 6992 6



Mode # 6 is for the wet lead acid batteries only. All chargers have this setting. This is the Default setting



Mode # 7 is for gel batteries only after charger serial 96117197 7 6992 6 and all 96137732 chargers.



Note 1: Settings 2, 3 and 4 are the same as 5 on the 96137732 charger.

Note 2: Settings 2, 3, 4 and 7 are the same as 5 before serial number 96117197 7 6992 6.

Note 3: Do not use other settings on chargers after serial number 96117197 7 6992 6.

11. To save the desired mode, press and hold the button for more than 5 seconds and release. The picture on the display will blink rapidly indicating the setting has been stored.
12. To end the programming mode function, wait about 60 seconds. The charger will automatically return to its normal operation.
13. Unplug the X31 jumper connector on the main control board harness for the gel and AGM maintenance free batteries. Connect the X31 plug to the harness for the lead acid type batteries. Secure the X31 connector with a plastic tie in the control board area when not in use.
14. Install the plastic cover with the nut and washer.
15. Install the two screws and secure the charger/controller cover to the original position.

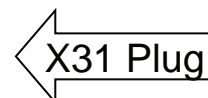

11.6 Replacing the Charger Harness

- When replacing the charger output harness (W8) 97094346 on 19 gallon models or 011722530 on 30 gallon models with the electric brake.
 - Inspect the receptacle on the charger for burnt or damage. Replace the charger if it is damaged.
 - Use a coating of high temperature dielectric grease (NYOGEL 760G GREASE) or equivalent, on the pins of the plug of the harness, before connecting the new harness to the charger.
-

12. Batteries

12.1 Maintaining Wet Lead Acid Batteries

1. Always keep the water levels above the plates
2. Fill cells with distilled water only. Tap water can cause an excessive build up of minerals and reduce the chemical reaction of the batteries. This will shorten the life and performance of the batteries.
3. Use an appropriate filling device, when filling the batteries. Do not use a garden hose. Flooding the batteries can flush the electrolyte out of the battery and shorten its life.
4. Fill cells 3/8 to 1/2 of an inch above the separators. Do not fill above the fill the marker of the batteries. Over filling can cause the electrolyte to percolate out onto the case while charging.
5. Check water level daily. Fill, if needed.
6. Keep all the battery cable connections tight.
7. Keep all the battery posts and cables clean. Clean the battery cases with a mixture of baking soda and water solution or commercial spray that neutralizes the acid. Spray the cases with a water displacement chemical or a silicone. This will help break the flow of current across the case and reduce the discharge rate .

Note: The electrolyte on the surface of the case can cause:

- A. The batteries to discharge faster even while sitting and have a shorter run time.
- B. The battery charger to stay on for extended periods. Thus causing an over charge condition and shortening the life of the batteries.
- C. Never leave batteries in a discharged state for long period of time.

12.2 Load Testing Batteries

12.2 Load Testing

Load test battery with an automotive type load tester. This test puts an ampere load on the batteries and measures the voltage at the same time. If voltage drops too low on the meter this would indicate that the batteries are weak or discharged. Load testing can identify dead cells, broken or disconnected plates, and cells or charge status. This is good test however, it can only detect these types of failures. See Specific Gravity Test for additional tests.

12.3 Hydrometer Testing Batteries

12.3 Hydrometer Testing on Lead Acid Wet Batteries

- Hydrometer testing can used to measure the specific gravity of deep cycle batteries. This allows you to detect weak cells, which are causing loss of running time. It can only detect these types problems. The hydrometer should have specific gravity markings such as 1.265, 1.250, 1.225, and so on.
- Hydrometers with the four balls are not accurate enough for this test and are not recommended.
- Fully charged batteries should read 1.265 and will decrease as batteries are discharged until they reach 1.120. This test should be done when batteries are charged and cooled. Allow one hour or more to cool. It can also be done after batteries are partially discharged, if they are allowed to cool. However, you will not be able to detect the full capacity of the battery.
- To do an accurate test, the battery water level must be high enough to extract enough electrolyte to fill hydrometer enough so that the indicator floats. If the water levels are low, water should be added prior to charging in order to let the electrolyte to mix.
- The greater the variation between cells readings, the greater the loss of run time. For example, if the readings are 1.265, 1.265 and 1.225 in one 6 volt battery. The low cell would be considered weak and greatly reduce the performance of the battery or shorter run time. This battery would have a point 40 variation. Batteries that have weakened cells in most cases it can still be used as long they continue provide adequate run time. A battery with a point 40 variation or more should be determined defective.

12.3 Batteries (Wet Lead Acid)

- Bortek batteries are rated for 500 charge cycles.
Every time the batteries are charged it uses one cycle.
To insure getting the expected life, unnecessary charging should be avoided.
- The specific gravity will reflect the percentage of charge remaining in the battery.
- 100% charge = 1.265 and above Specific Gravity
- 75 % charge = 1.225 Specific Gravity
- 50 % charge = 1.190 Specific Gravity
- 25 % charge = 1.120 Specific Gravity
- Note : Gel maintenance free-batteries can not be tested with the hydrometer.
Do not attempt to open cell covers or caps. Doing so will destroy the battery.

13. Fuse Locations (Version 2 Controller)

All the fuses are located on the main control circuit board.

Part Numbers

00059580 Fuse 125 Amp 80 Volts (Brush & Vac. Motors)
00972420 Fuse 100 Amp. 80 Volts (Brush & Vac. Motors)
00733630 Fuse 10 Amp. 32 or 80 Volts (Pump & Water Sol.)
00902440 Fuse 50 Amp. 80 Volts (Drive)
00972430 Fuse 2 Amp. 32 Volts (Switch)

Note: If the 2 amp fuse blows, check the main contactor for bad contacts.

Warning: Do not substitute the value of the 50, 100 and 125 amp fuses.

They must be correct voltage and amperage. Doing so will produce system errors. Fuses are used as shunts in the circuit.

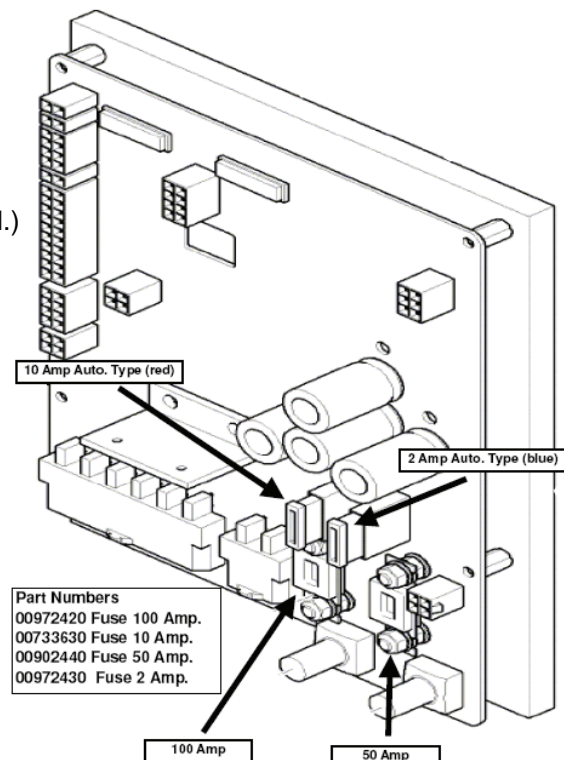

13.1 Fuse Locations (Version 3 Controller)

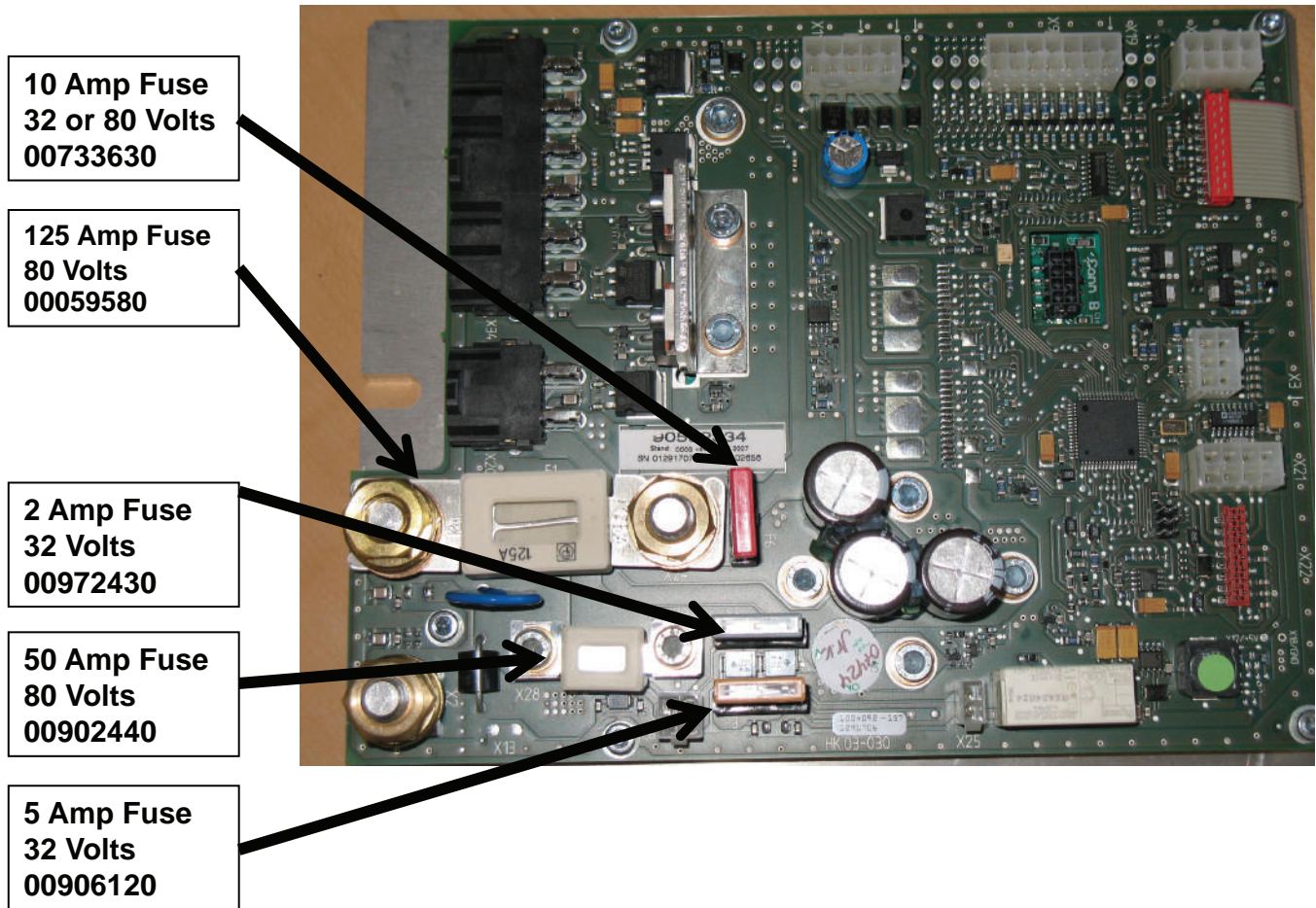

14. Controller Connections

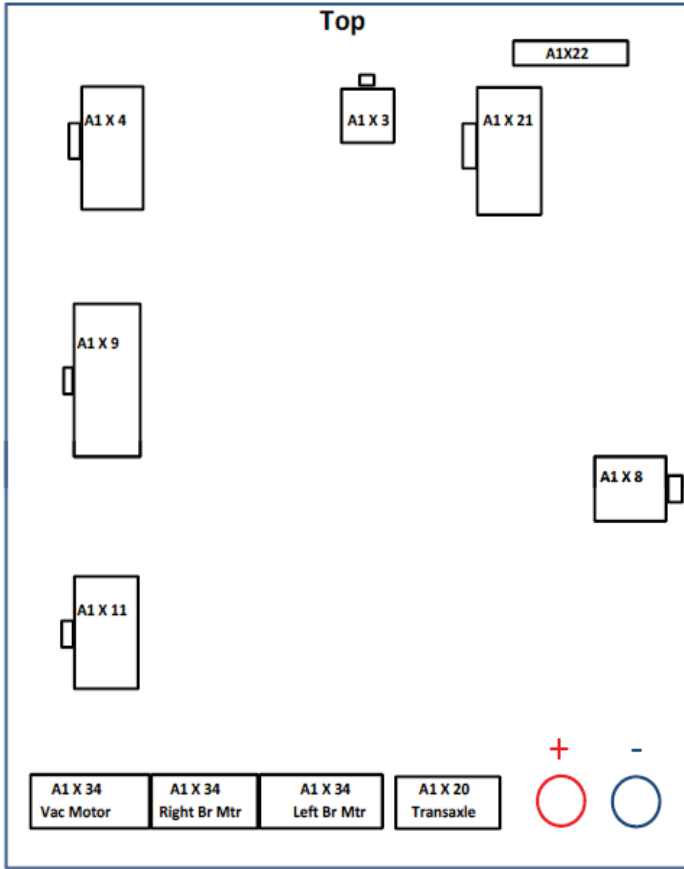

A1 X 4		
Potentiometer wiper	5 1	Deadman switch left side
Potentiometer & deadman switch	6 2	No connection
Potentiometer	7 3	Drive switch forward
No connection	8 4	Drive switch reverse

A1 X 9		
Brush motor thermo switch	8 1	Brush motor thermo switch
Transaxle thermo switch	9 2	Transaxle thermo switch
Vacuum motor switch	10 3	Vacuum motor switch
Brush motor switch	11 4	Brush motor switch
Acoustic warning Switch	12 5	Acoustic warning Switch
Battery type X31 connector	13 6	Battery type X31 connector
No connection	14 7	No connection

A1 X 34					A1 X 20	
5	6	4	3	2	1	1 Red 2 Black
Vac motor Rt br mtr				Left br mtr		Transaxle

A1 X 21		
To G2 X3 pin 1 (Charger) (org-white)	5 1	To G2 X 2 pin 1 (Charger) Relay (org-blue)
To G2 X3 pin 4 (Charger) (org-white)	6 2	To G2 X 2 pin 2 (Charger) Relay (org-blue)
To G2 X3 pin 2 (Charger) (black-red)	7 3	To G2 X3 pin 6 (Charger) (org-white)
To G2 X3 pin 5 (Charger) (red-black)	8 4	To G2 X3 pin 3 (Charger) (org-white)

A1 X 8		
To Contactor K1:1 (Contact Pos.)	2 4	To Contactor K1:3 (Contact Neg.)
To Contactor K1:A2 (Coil Neg.)	1 3	To Contactor K1:A1 (Coil Pos.)

A1 X 3	Not Used	A1X22	Ribon Cable (Display)
--------	----------	-------	-----------------------

A1X11		
Acoustic Alarm Output	6 1	Acoustic Alarm Output
NC	7 2	NC
Water Solenoid	8 3	Water Solenoid
Water Pump	9 4	Water Pump
Electric Brake Coil (if Equipped)	10 5	Electric Brake Coil (if equipped)

15. Trouble Shooting the Controller

Note: If the 5 amp fuse on the controller blows, It could indicate:

1. A faulty contactor (not closing on the negative side).
2. Poor connection on the battery negative side of the contactor.
3. Poorly crimped terminals on the contactor connections.
4. Incorrect wiring of the contactor. (See chapter 16-17)

•NOTE - Always use a coating of high temperature dielectric grease (NYOGEL 760G GREASE) or equivalent on the motor connectors on the bottom of the controller when replacing the board or motor harnesses.

Caution: Connecting the battery pack polarity incorrectly will permanently damage the controller.

16. Contactor Wiring – Harness

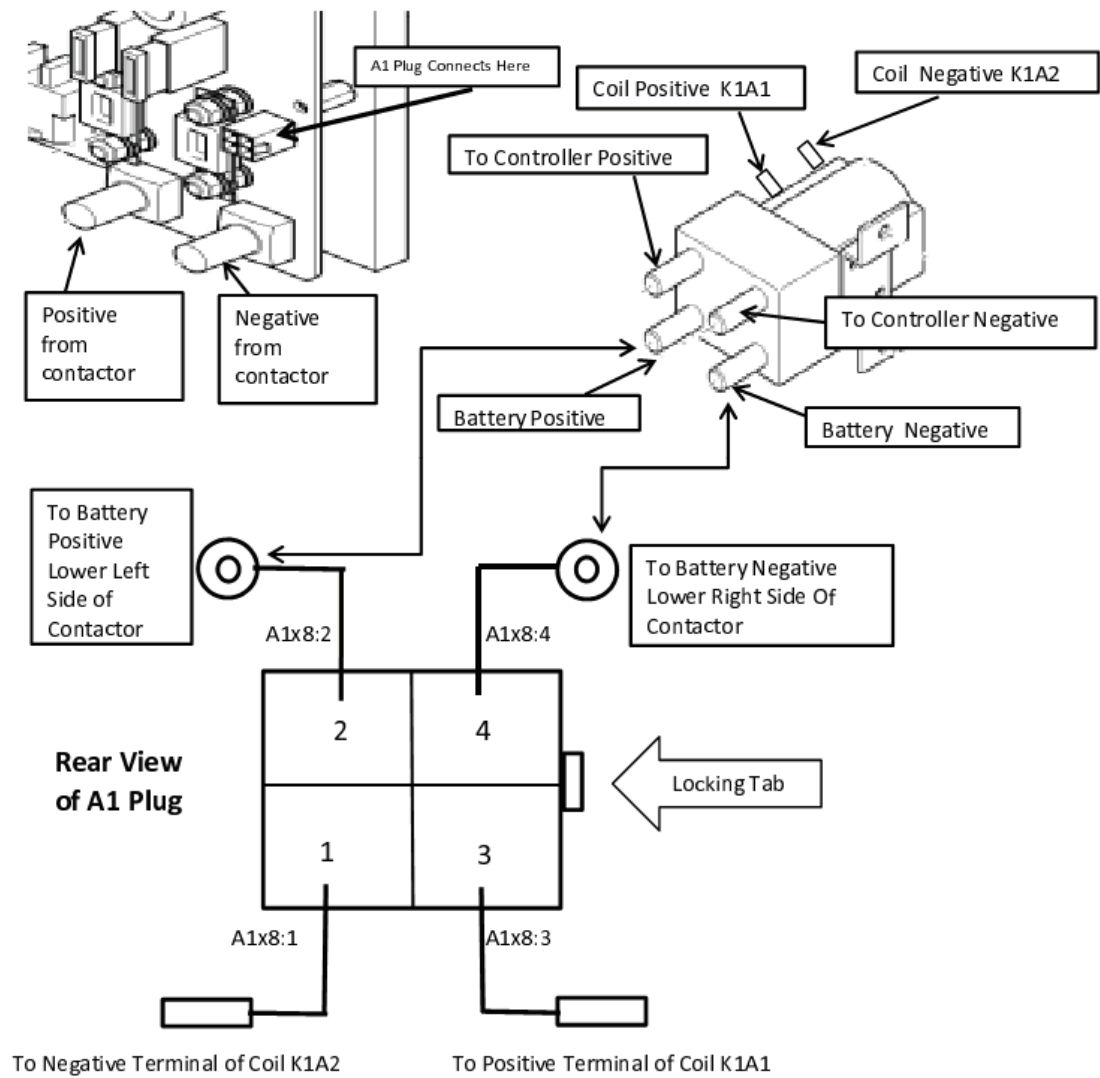

17. Contactor Wiring

Proper wiring of the contactor is critical

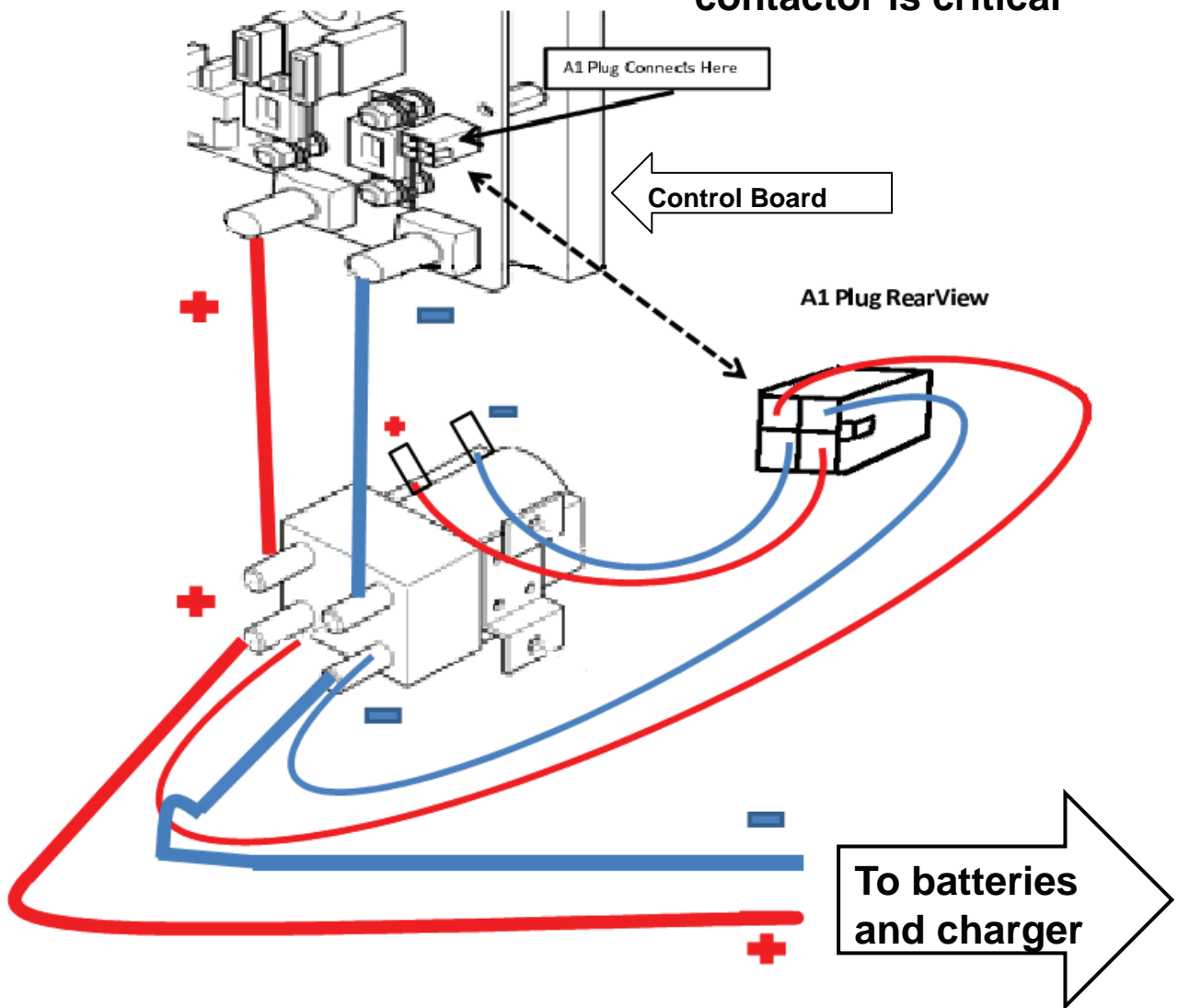



HAMMERHEAD®



450 RS



500 RS



500 SS



600 SS



650 RS



750 RS



550 RDX



650 RDX



700 RSX



750 RDX



870 SR

HEADQUARTERS

4713 Old Gettysburg Road
Mechanicsburg, PA 17055 USA

CONTACT US

800.6.Bortek

717.737.7591

Orders@BortekIndustries.com

BortekIndustries.com/[CUSTOMER LINK](#)

SWEEPERLAND.COM

A complete family of
power cleaning machines.