

CONFIDENCE IN CLEANING™

FEATURE	500RS GEN II	500RSX	500SS GEN II
MACHINE CATEGORY	Scrubber	Scrubber	Sweeper/Scrubber
CLEANING METHOD	Disc	Disc	Cylindrical
SCRUBS	✓	✓	✓
SWEEPS			✓
DOUBLESCRUBS			✓
NON-MARKING WHEELS	✓	✓	✓
BREAK-AWAY SQUEEGEE	✓	✓	✓
TOOL FREE SQUEEGEE CHANGE	✓	✓	✓
URETHANE SQUEEGEE BLADES	✓	✓	✓
ON-BOARD BATTERY CHARGER (110V)	✓	✓	✓
CHARGING SAFETY LOCK-OUT	✓	✓	✓
ADJUSTABLE HANDLE CONTROLS	✓	✓	✓
CAST ALUMINUM SCRUB DESK	✓	✓	✓
TOOL-FREE BRUSH CHANGE	✓	✓	✓
HANDS-FREE BRUSH CHANGE	✓	✓	
SIPED URETHANE DRIVE TIRES		✓	✓
NON-CORROSIVE DEBRIS TRAY			✓
PERFORMANCE RATING (FT2/HR)	15,000	20,000	20,000
CLEANING PATH	20"	20"	20"
BRUSH RPM	180	180	600
NUMBER OF BRUSHES	1	1	2
RECOVERY CAPACITY (GALLONS)	13	13	13
SOLUTION TANK CAPACITY (GALLONS)	12	12	12
SOUND LEVEL (DBS)	<70	<70	<70
PROPULSION	Brush Assist	Traction Drive	Traction Drive
RATED VOLTAGE	24	24	24
VACUUM FLOW (CFM)	65	65	65
VACUUM WATERLIFT (INCHES)	45	45	45
SQUEEGEE WIDTH (INCHES)	33	33	33
WEIGHT WITH BATTERIES (LBS)	313	360	360
WARRANTY (PARTS & LABOR)*	36 Months	36 Months	36 Months

*See Warranty Statement for details

Available Exclusively at Bortek

First in Power Cleaning Equipment

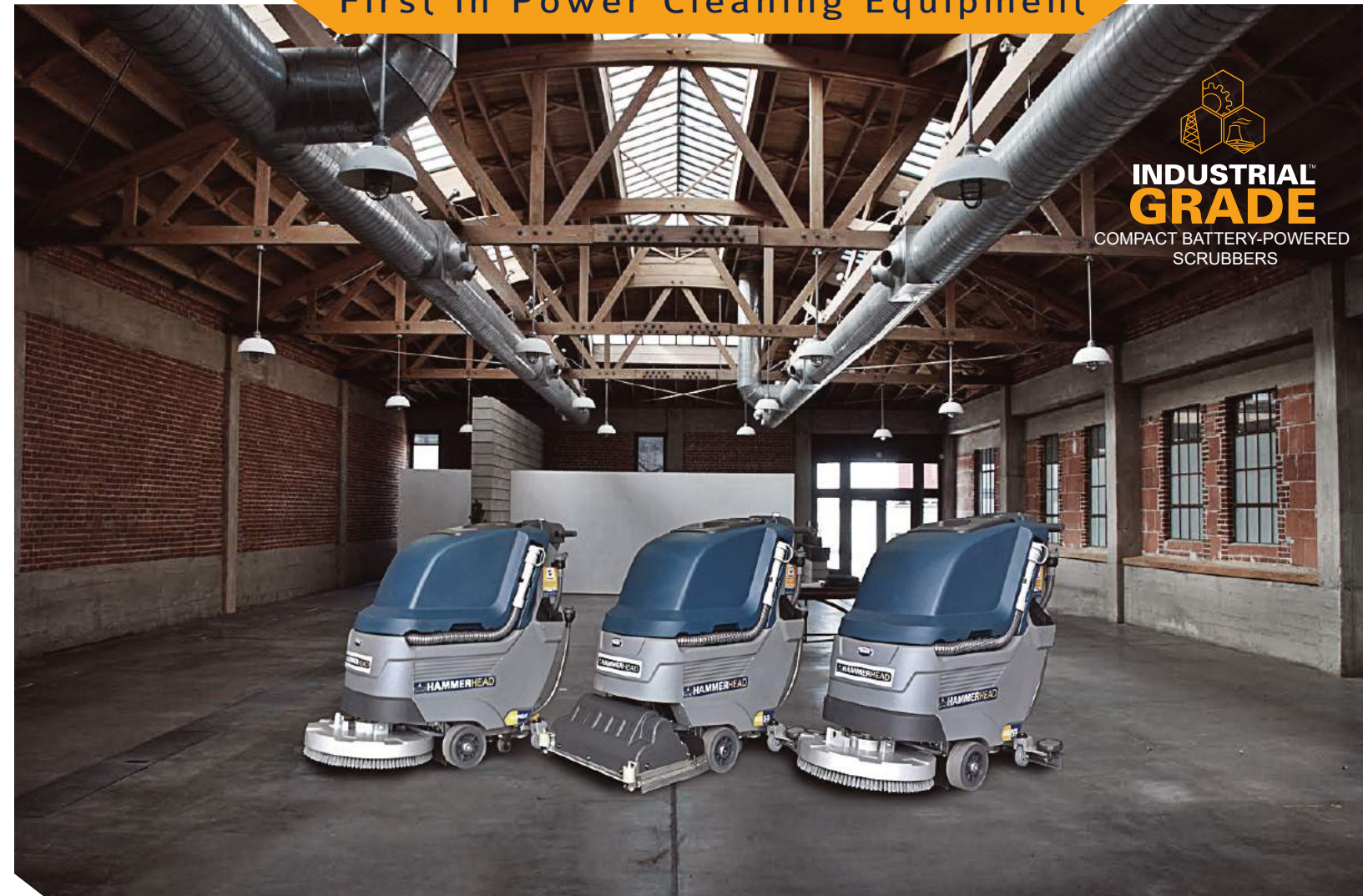

**INDUSTRIAL
GRADE**

COMPACT BATTERY-POWERED
SCRUBBERS



HAMMERHEAD

500SERIES

ENGINEERED SIMPLICITY™

500RSX/SS/RS
GEN II GEN II

SWEEPERLAND.COM

SWEEPERLAND.COM

SERVICE & FULFILLMENT CENTERS

PENNSYLVANIA LOCATIONS

4713 & 4719 Gettysburg Rd | Mechanicsburg, PA 17055
105 North 16th St | Lebanon, PA 17046
11070 Parker Dr | North Huntingdon, PA 15642
1318 Bob Mellow Dr | Olyphant, PA 18434

NEW JERSEY LOCATIONS

2702 Cindel Dr, Unit 1 | Cinnaminson, NJ 08077
100 North 12th St | Kenilworth, NJ 07033

CONNECTICUT LOCATION

39A N Plains Industrial Rd | Wallingford, CT 06492

800.6.Bortek Quotes@Sweeperland.com

Order online 24/7 with **CUSTOMERLINK**



EQUIPMENT



PARTS



RENTALS



SERVICE



SUPPLIES

YOUR FACILITY SOLUTIONS RESOURCE™

KEY COMPONENTS



HAMMERHEAD®

ENGINEERED SIMPLICITY™

EASY
PREP.
OPERATION.
MAINTENANCE.
RESULTS.

Finally, a set of floor scrubbers to choose from that have all the power and productivity you've been looking for. We've worked really hard to ensure our **500 Series** are the perfect power cleaning machines to choose from for your specific situation and environment.

This series includes three 20" models: the **500RSX**, **500RS**, and the **500SS**. The **500 RS** and **RSX** are both **Disc Brush** models. The only real difference between the two is the **RSX** has *traction drive* (the machine moves under its own power) while the **RS** is *brush assisted* (you push the machine but while in operation, the brush will pull it along, making the effort of moving the machine negligible). As we mentioned, these machines are disc scrubbers, so they allow for a deeper clean and are great if you have an environment that is pre-swept before use.

The **500SS**, meanwhile, is our **Cylindrical Brush** model. This machine also has *traction drive*. Being a cylindrical model, it has two brushes in its scrub deck along with a **corrosion-proof hopper tray**. This allows it to scrub twice (double scrub) and sweep your floors while tossing any debris in its way into the on-board hopper so there's no need for pre-sweeping before operation.

The 500 Series Scrubbers also have on-board chargers for easy recharge after use, convenient manual levers to lower/raise the squeegee and brush deck (effectively eliminating any costly electronic actuator problems other walk-behind scrubbers tend to have), and cast aluminum and polymer components are used for rust free operation.

We've got you covered when it comes to operating these machines. Common sense is hard-wired into them in order to be as user-friendly and intuitive as possible, allowing you to focus on keeping your facility in pristine condition with the effective cleaning power of **HAMMERHEAD**.



Our line of 500 Series scrubbers have proven themselves worthy of the HAMMERHEAD name. With effective and efficient cleaning power, these machines are designed to tackle even the most grueling scrubbing demands your facility has. Sure, that's great and all, but what makes these such great tools to have is that they are designed with a heavy dose of the all-too-rare common sense. "Engineered Simplicity" isn't just a tagline. It's our way of thinking. We've worked really hard to make these machines easy to operate and maintain. Even better, these monsters will keep your facility in pristine condition, making it cleaner and healthier for your employees and customers alike. Everybody wins.

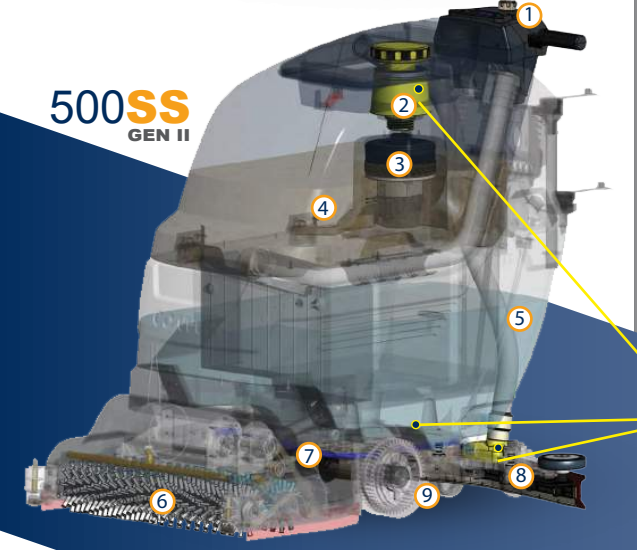
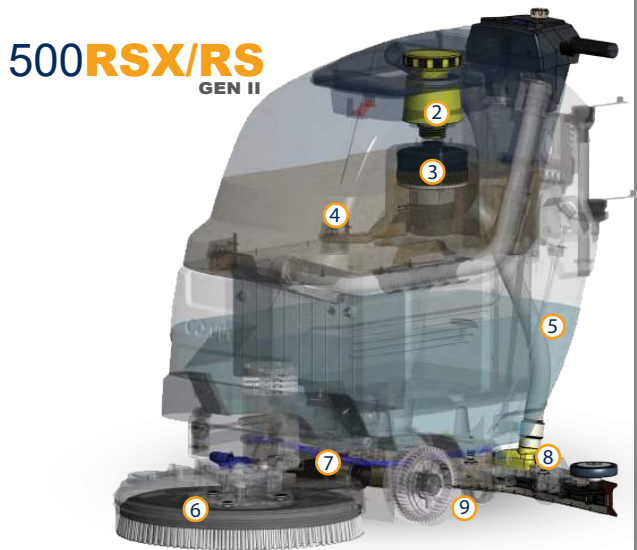

- 1 Intuitive Controls for ease of operation.
- 2 Float Switch for motor protection.
- 3 Suction Motor
- 4 Recovery Tank
- 5 Solution Tank
- 6 Disc Brush (500RS/RSX)
Cylindrical Brushes (500SS)
- 7 Traction Drive Motor (500 SS/RSX)
- 8 Break-away, V-Shaped Squeegee
- 9 4-wheel stance for greater stability while in use.
- 10 Emergency Shut-Off (SS/RSX)

Yellow color-coded components can be found around the machine for an easier daily inspection of crucial parts that should be sanitized after use. It just makes good sense to have those be easy to find, right?



Operate your 500 Series Floor Scrubber with its intuitive controls.



Fill the solution tank easily by using the most convenient methods.



The 500 RSX and SS come with an emergency shut-off button for immediate cease of operation.