

Adgressor™, Adgressor™ EcoFlex

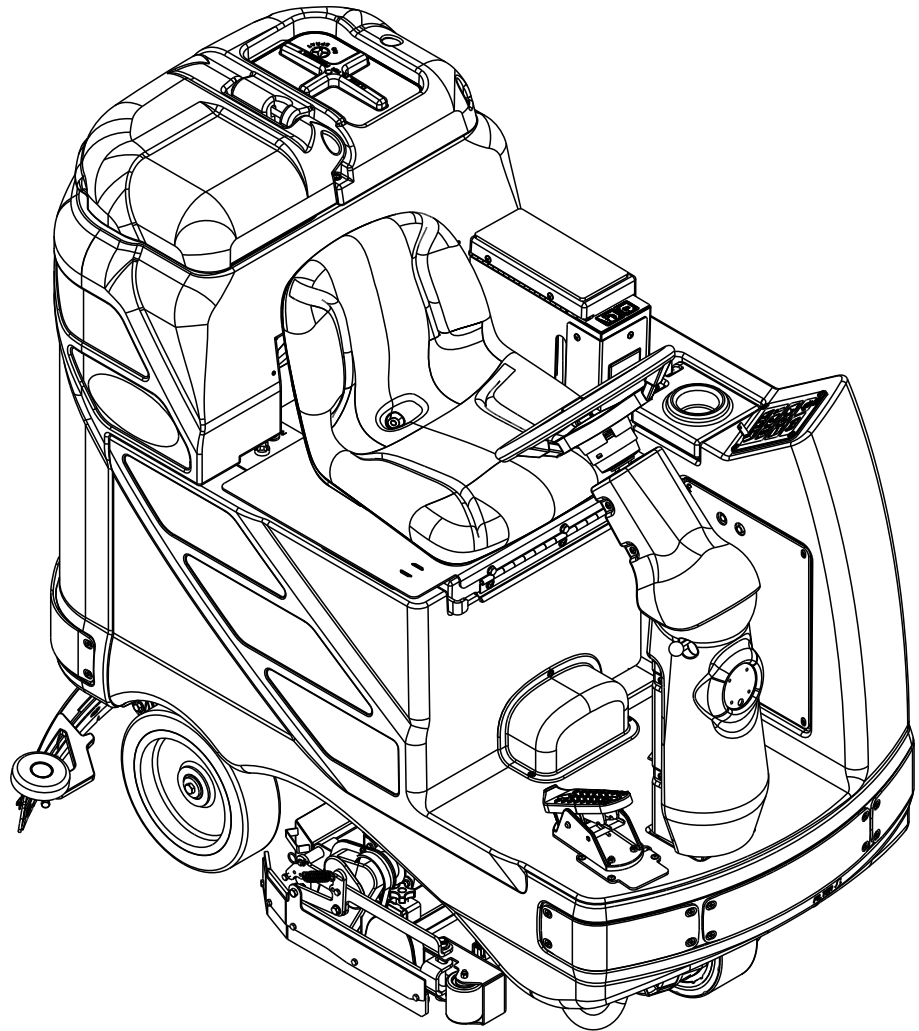

PARTS LIST

Standard Models:

56390900(2820D), 56390904(3220D), 56390902(2820C), 56390906(3220C)

56390908(3520D), 56390912(3820D), 56390910(3520C), 56390914(3820C)

Obsolete AXP Models:

56390903(2820C-AXP), 56390901(2820D-AXP), 56390907(3220C-AXP), 56390905(3220D-AXP)

56390911(3520C-AXP), 56390909(3520D-AXP), 56390915(3820C-AXP), 56390913(3820D-AXP)

EcoFlex Models:

56381000(X2820D), 56381003(X3220D), 56381005(X3520D), 56381007(X3820D)

56381002(X2820C), 56381004(X3220C), 56381006(X3520C), 56381008(X3820C)



Advance

DESCRIPTION	PAGE
Chassis System	2-3
Decal System.....	4-5
Detergent Injection System.....	6-7
Drive & Brake Pedal Assemblies	8-9
Electrical Panel Assembly.....	10-11
Front Wheel Assembly.....	12-13
Recovery System.....	14-15
Scrub System-Cylindrical (28", 32" Models)	16-17
Scrub System-Cylindrical (35", 38" Models)	18-19
Scrub System-Disk 28-32 Inch Models.....	20-21
Scrub System-Disk 35-38 Inch Models.....	22-23
Skirt Assemblies-Cylindrical (All Models).....	24-25
Skirt Assemblies-Disk (28", 32" Models).....	26-27
Skirt Assemblies-Disk (35", 38" Models).....	28-29
Solution System (Standard).....	30-31
Solution System (EcoFlex)	32-33
Squeegee Assy.....	34-35
Squeegee System	36-37
Steering Column Assembly.....	38-39
Battery Watering System	40-41
Wiring Diagram	42-43
Optional Kits & Accessories.....	44-45
Brush Selector Guide-Disk	46
Brush Selector Guide-Cylindrical.....	47
Squeegee Blade Selector Guide	48

WHEN ORDERING PARTS

- * Use the numbers from the "Ref. No." columns in this parts list.
- * Specify the model and serial number of the machine.
- * Use the space below to record the model and serial number for future reference.

Model _____ Serial No. _____

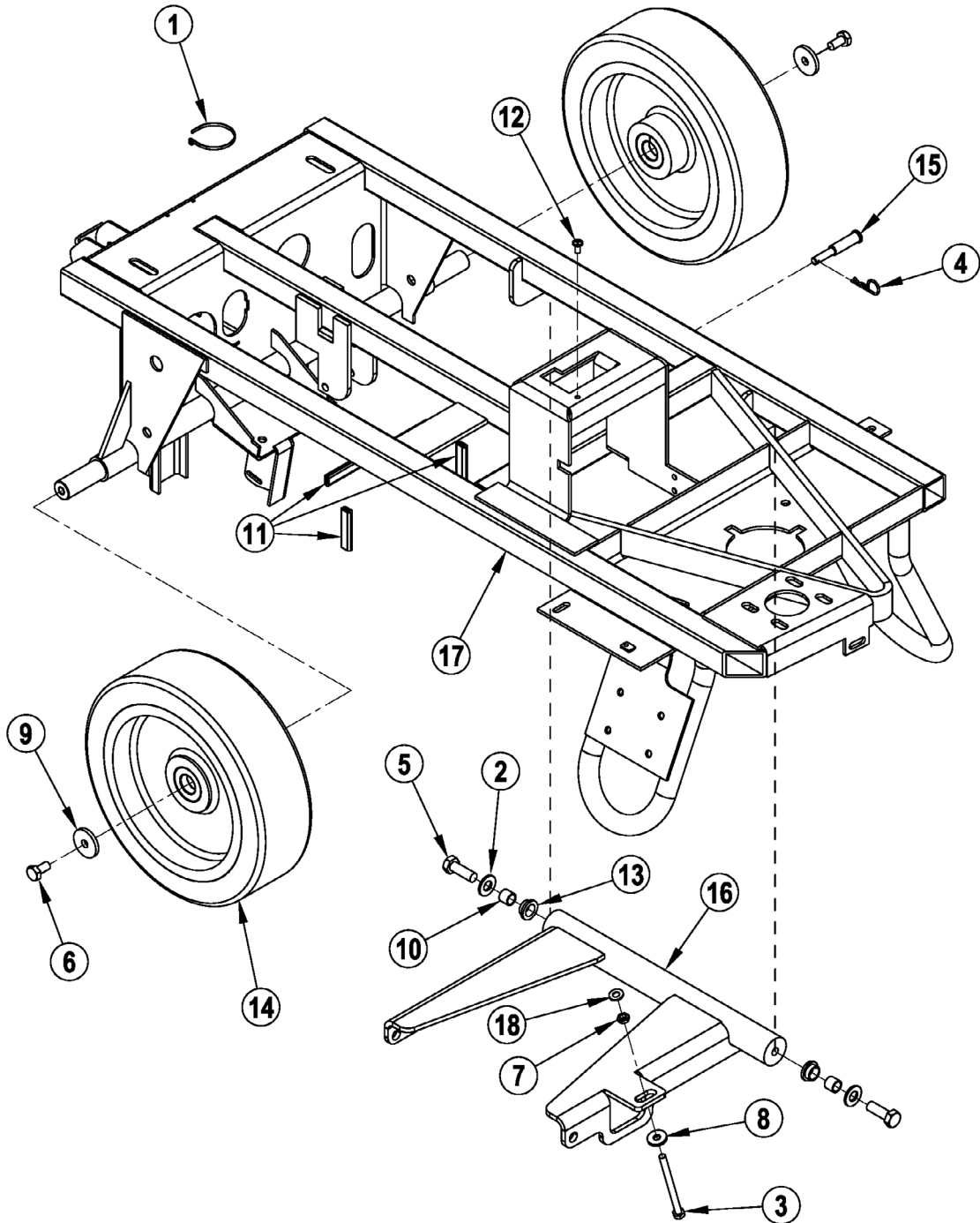

Item	Ref. No.	Qty	Description
1	56478246	1	Tie, Cable
2	56001879	2	Wsh, Flt SAE 1/2
3	56002461	1	Scr, Hex Thd To Hd 5/16-18 x 4.00
4	56002959	1	Pin, Cotter Hair
5	56003412	2	Scr, Hex Nyl Loc M12-1.75 x 35mm
6	56003442	2	Scr, Hex Nyl Loc M10-1.50 x 20mm
7	56009086	1	Nut, Hex Jam 5/16-18
8	56009122	2	Wsh, Flt .344 x .938 x .125
9	56367117	2	Wsh, Flt .406 x 1.50 x .1875
10	56367206	2	Bushing
11	56412122	4	Trim Edge
12	56009062	1	Scr, Pan Phil Thd Form 1/4-20 x .50
13	56420160	2	Bearing, Flange
14	56601482	2	Assembly, Wheel and Bearing (each assembly includes two bearings)
	56412243	4	Bearing, Ball
15	56314152	1	Pin, Actuator
16	56314495	1	Linkage, Arm Weld't.
17	56390803	1	Weldment Chassis
18	56009052	1	Wsh-Int Shprf 5/16
[]	56478246	5	Cable Tie
[]	56477613	9	Cable Tie

[] = Not Shown

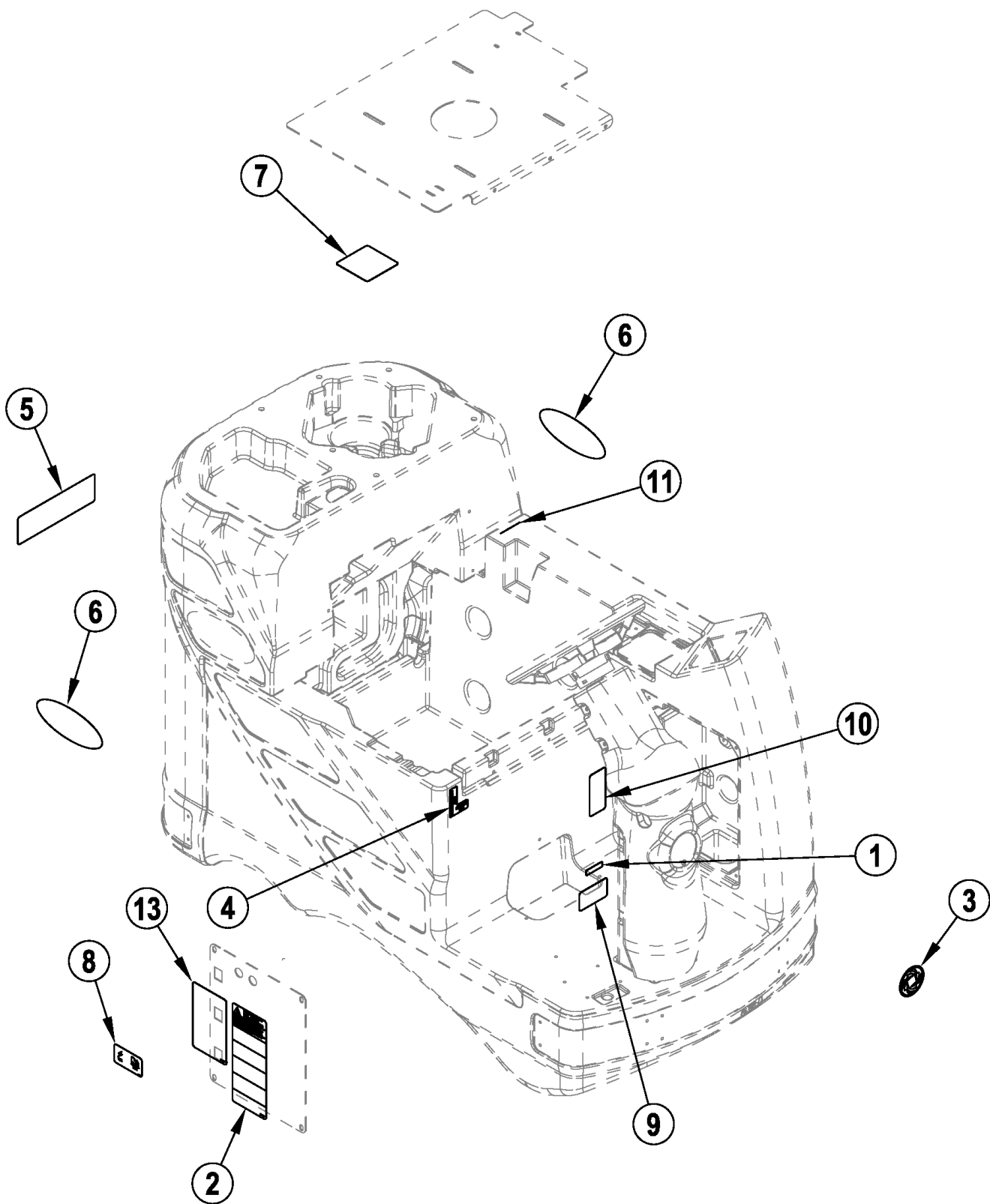

09-9

DECAL SYSTEM

10-1

Adgressor™**5**

Item	Ref. No.	Qty	Description
1	56014450	1	Decal, Patent Number
2	56014601	1	Decal, Caution
3	56015276	1	Decal, Logo
4	56015179	1	Decal, Emergency
5	56015229	1	Decal, Advance
6	56015230	2	Decal, Adgressor
	56016638	2	Decal, Adgressor AXP NOTE 1
	56381110	2	Decal-Adgressor EcoFlex NOTE 2
7	56015242	1	Decal, Battery Wiring
8	56016328	1	Decal, Circuit Breaker
9	56016401	1	Decal, Parking Brake
10	56015445	1	Decal, Solution Flow (not used on AXP or EcoFlex models)
11	56015281	1	Decal, Logo 2 Inch
13	56016407	1	Decal, Smart Solutions

NOTE 1: Only used on AXP models.

NOTE 2: Only used on EcoFlex models. AXP models are no longer in production and have been replaced by EcoFlex models.

DETERGENT INJECTION SYSTEM

09-9

6

Adgressor™

10-1

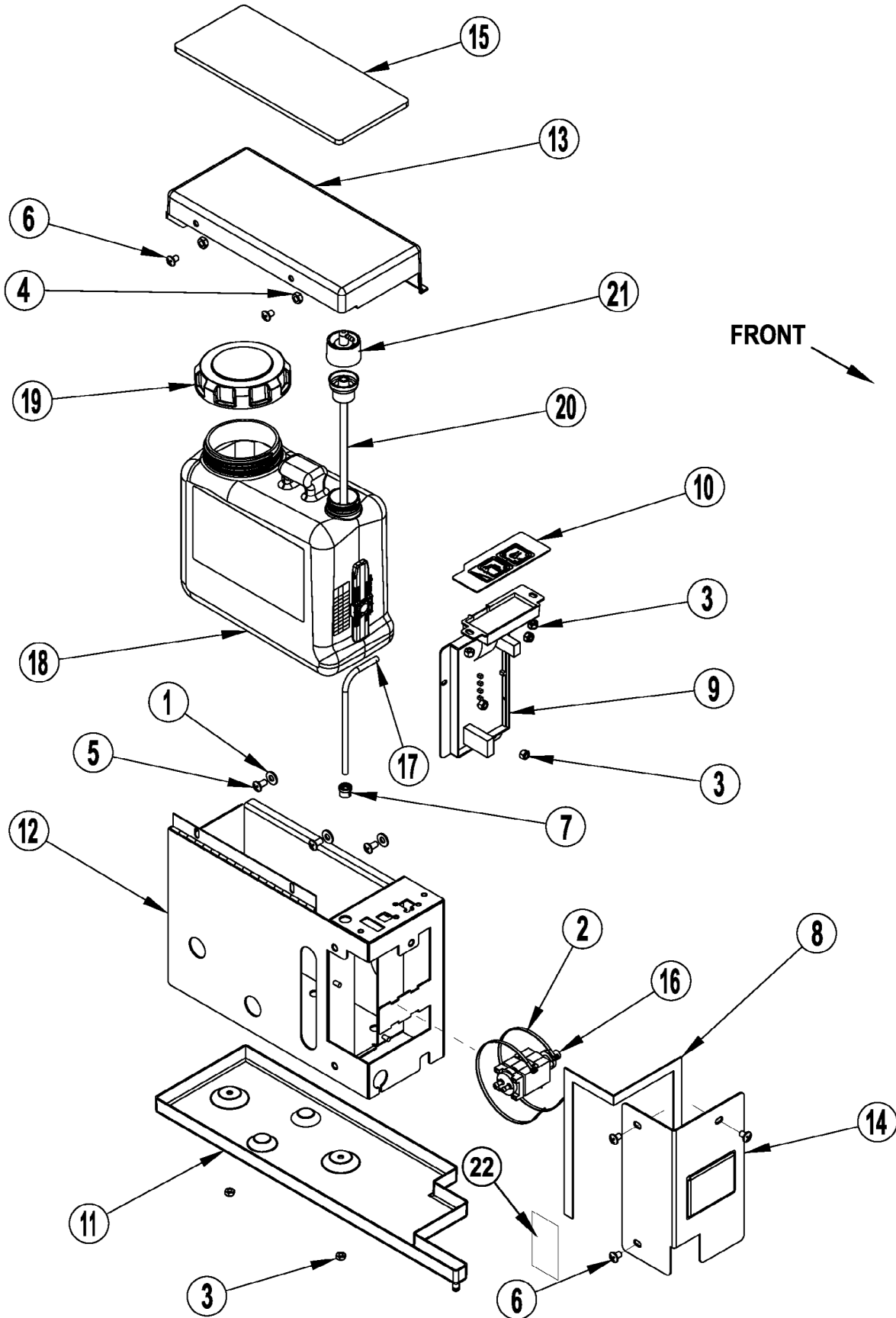

Item	Ref. No.	Qty	Description
	56316537	1	Detergent Injection Assembly (items 1-21) NOTE 1
	56381100	1	Detergent Injection Assembly (items 1-22) NOTE 2
1	56009025	3	Wsh, Flt .266 x .750 x .036
2	56478523	2	Tie, Cable
3	56002832	8	Nut, Hex Nyl Loc-Thin 10-24
4	56002840	2	Nut, Hex Nyl Loc-Thin 1/4-20
5	56002145	3	Scr, Pan Phil 1/4-20 x .50
6	56003580	5	Scr, Pan Phil SS 1/4-20 x .38
7	56003699	1	Bushing, 1/4 ID Snub
8	56200754	1	Gasket, Strip
9	56316110	1	Control Assembly NOTE 1
	56381078	1	Control Assembly NOTE 2
10	56314937	1	Control Decal NOTE 1
	56381056	1	Graphic Overlay NOTE 2
11	56314939	1	Tray, Detergent
12	56314944	1	Weldt-Detergent Box NOTE 1
	56381102	1	Weldt-Detergent Box NOTE 2
13	56314945	1	Cover, Detergent
14	56314946	1	Cover, Pump
15	56314953	1	Pad, Detergent
16	56314984	1	Pump, Detergent
17	56314991	1	Hose, Chem Resistant 14"
18	56315502	1	Chemical Bottle Assy NOTE 1
	56315511	1	Indicator Assy NOTE 1
**	56315503	A/R	Chem Bottle Assy (18-20) NOTE 1
	56601544	1	Chemical Bottle Assy NOTE 2
	56601545	1	Chem Bottle Assy (18-20) NOTE 2
19	56315517	1	Cap, Raw
20	56315527	1	Insert, Dry Break
21	56315523	1	Cap, Dry Break, 1/8 Barb, 90°
22	56381113	1	Decal-Chemical Ratio NOTE 2

NOTE 1: Only used on AXP models.

NOTE 2: Only used on EcoFlex models. AXP models are no longer in production and have been replaced by EcoFlex models.

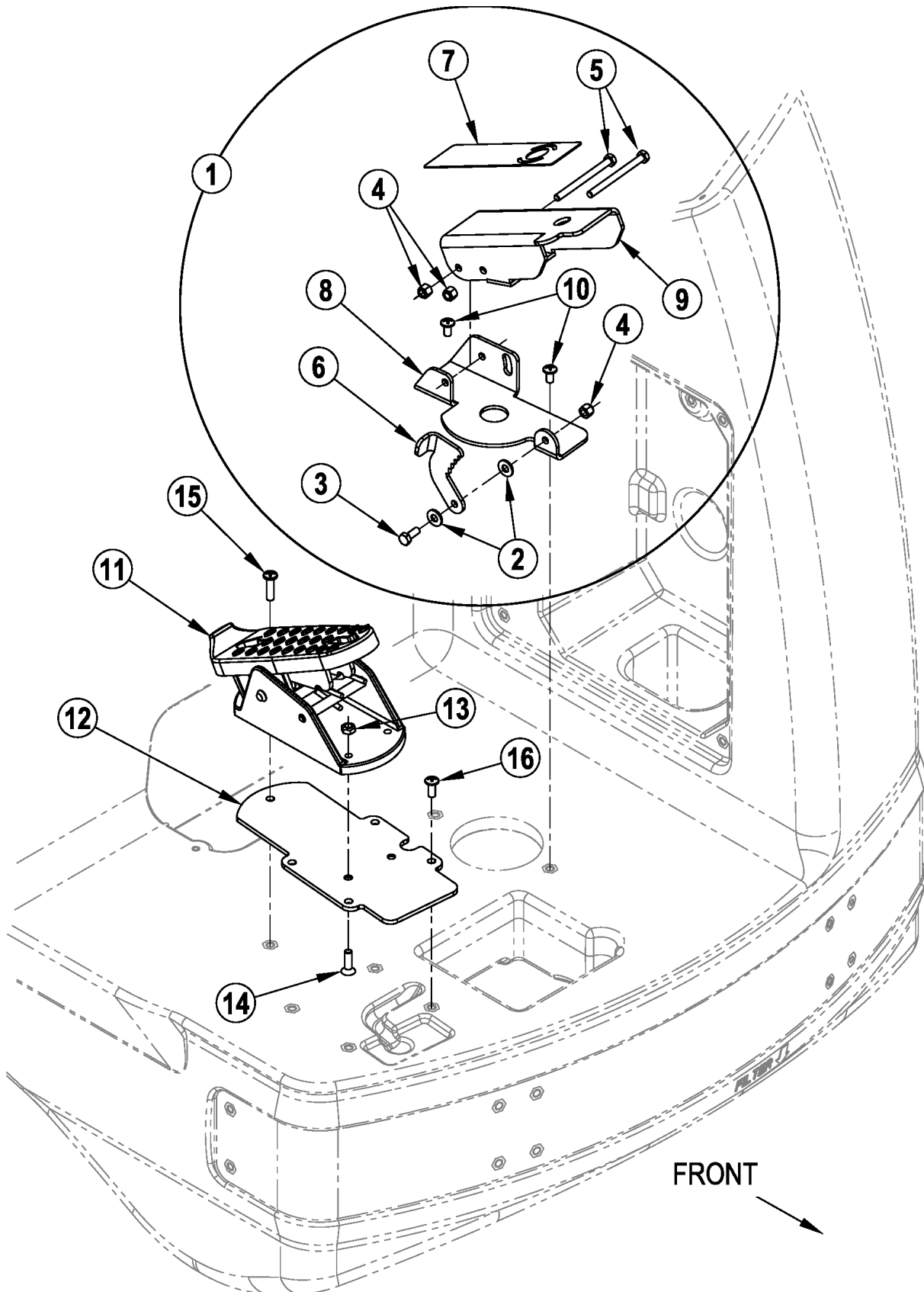

Item	Ref. No.	Qty	Description
1	56314676	1	Brake Pedal Assy (2-9)
2	56002098	4	Wsh, Flt SAE 1/4
3	56003174	1	Scr, Hex Thd to Hd M6-1.0 x 16mm
4	56003403	5	Nut, Hex Nyl Loc M6-1.00
5	56003428	3	Scr, Hex M6-1.00 x 75mm
6	56314122	1	Lock, Brake
7	56314138	1	Mat, Pedal
8	56314677	1	Bracket, Brake
9	56314678	1	Pedal Weldment
10	56003119	7	Scr, Pan Phil SS 1/4-20 x .50
11	56601052	1	Foot Pedal Assy
12	56390812	1	Foot Pedal Plate
13	56002473	2	Nut, Hex Flex Loc 1/4-20
14	56003086	2	Scr, Flt Phil Ss 1/4-20 x .88
15	56002292	1	Scr, Pan Phil 1/4-20 x 1.00
16	56002989	4	Scr-Pan Phil SS 1/4-20 x .62

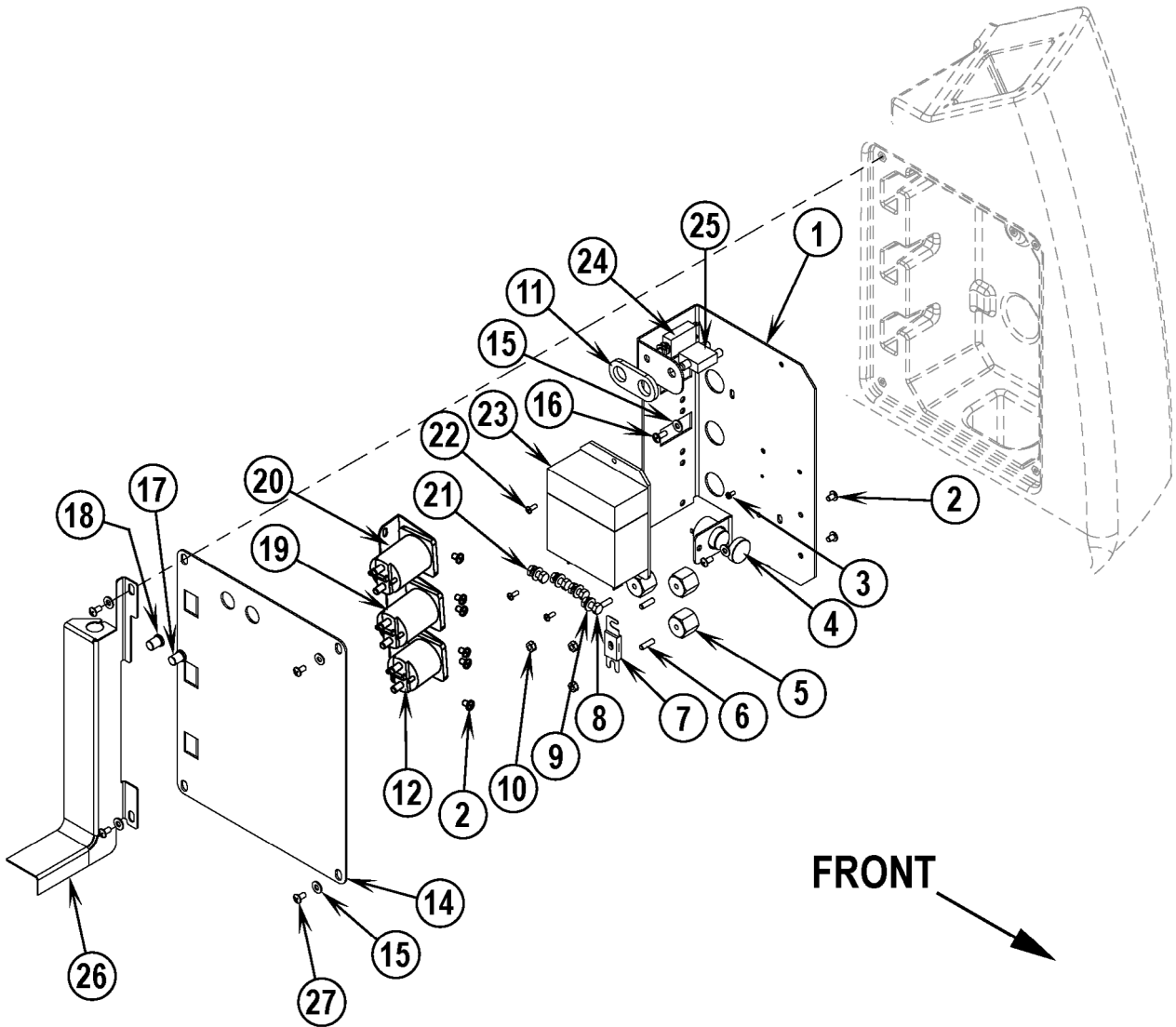

Item	Ref. No.	Qty	Description
1	56314668	1	Electrical Panel
2	56002462	9	Scr, Pan Phil 1/4-20 x .38
3	56009051	1	Scr, Pan Phil Thd Form 8-32 x .38
4	56412177	1	Horn / Backup Alarm (H1)
5	56469858	3	Standoff, Insulated
6	56009020	3	Stud
7	56412089	1	Fuse, 150 Amp
8	56001862	4	Scr, Hex Hd 5/16-18 x .50
9	56009052	4	Wsh, Int SHPRF 5/16
10	56002561	3	Nut, Hex W/SHPRF 1/4-20
11	56407193	1	Gasket
12	56395455	1	Contactor (Vac Motor / K2)
14	56109534	1	Cover, Electrical
15	56002098	6	Wsh, Flt SAE 1/4
16	56002066	2	Scr, Pan Phil 1/4-20 x .62
17	56459369	1	Boot, Reset Button
18	56459367	1	Boot, Reset Button
19	56395453	1	Contactor (Brush Drive / K1)
20	56395453	1	Contactor (Wheel Drive / K3)
21	56009086	4	Nut, Hex Jam 5/16-18
22	56001993	3	Scr, Pan Phil 10-24 x .50
23	56390856	1	Controller, Speed
24	56387316	1	Circuit Breaker, 10 Amp (Control Circuit / F3)
25	56454429	1	Circuit Breaker, 70 Amp (Wheel Drive / F2)
26	56314956	1	Weldment, Harness Guide (Detergent Injection models only)
27	56002989	4	Scr-Pan Phil SS 1/4-20 x .62

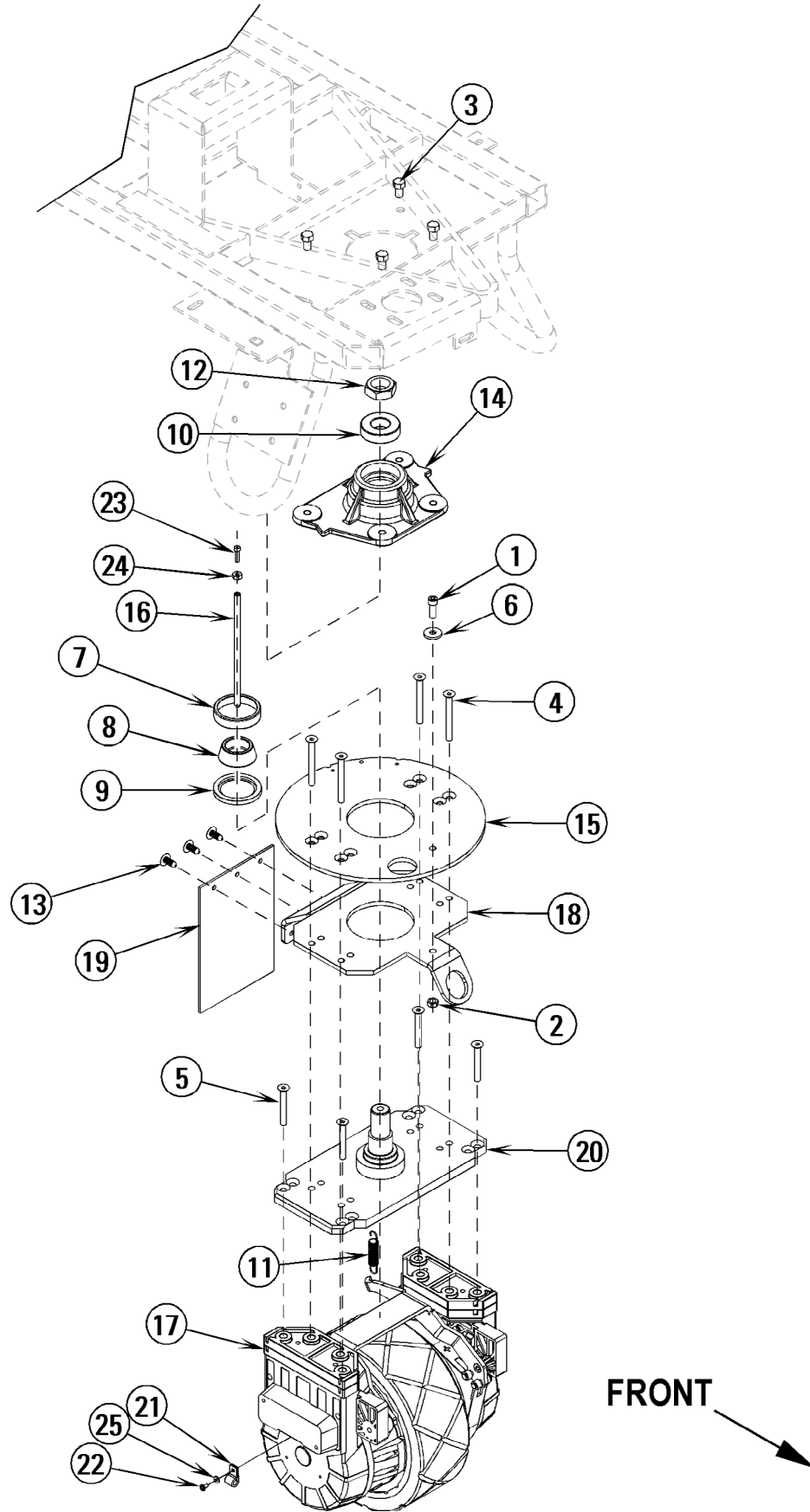

Item	Ref. No.	Qty	Description
1	56002158	1	Scr, Soc Hd 5/16-18 x .88
2	56002826	1	Nut, Hex Nyl Loc-Thin 5/16-18
3	56003040	4	Scr, Hex Hd Loc 3/8-16 x .62
4	56003273	4	Scr, Soc Hd M8-1.25 x 70mm
5	56003274	4	Scr, Soc Hd M8-1.25 x 55mm
6	56009122	1	Wsh, Flt .344 x .938 x .125
7	56158143	1	Bearing Cup
8	56158151	1	Bearing Cone
9	56171081	1	Seal, Shaft
10	56378380	1	Bearing, Ball
11	56481699	1	Spring
12	56003220	1	Nut, Hex Nyl Loc-Thin 1-14 UNF
13	56003263	3	Rivet, Nylon Tree Push-In
14	56314032	1	Block, Bearing
15	56314116	1	Plate, Steering
16	56314157	1	Rod, Brake
17	56390817	1	Motor / Drive Wheel Assy (M3)
[]	56381533	1	Front Wheel Service Kit NOTE 1
[]	56380506	1	Motor/Drive Wheel Kit
[]	56316637	1	Drive Wheel Harness Kit
[]	56314289	1	Brake Band
[]	56390814	1	Drive Wheel-Blue Urethane
[]	56412325	1	Carbon Brush Kit
[]	56412320	1	Brush Cover Kit
[]	56412321	1	Sealing Ring
[]	56412322	1	Bearing, ball Gearbox Side
[]	56412323	1	Bearing, Ball Brush Side
[]	56314282	1	Brake Bar
[]	56109589	1	Connector Box
[]	56109590	1	Cover-Connector Box
18	56314278	1	Plate, Splash Guard
19	56314283	1	Splash Guard
20	56314085	1	Spindle Weldment
21	56305317	1	Clamp, P
22	56003653	1	Scr, Pan Phil M4 x 8
23	56003611	1	Scr-Pan Phil SS 10-24 x .88
24	56009293	1	Nut, Hex Machine SS 10-24
25	56002006	1	Wsh, Flt SAE #6

[] = Not Shown

** = Optional

NOTE 1: Kit includes 1 Connection Box, 2 Curved Brushes, 1 Brush Holder and Hardware.

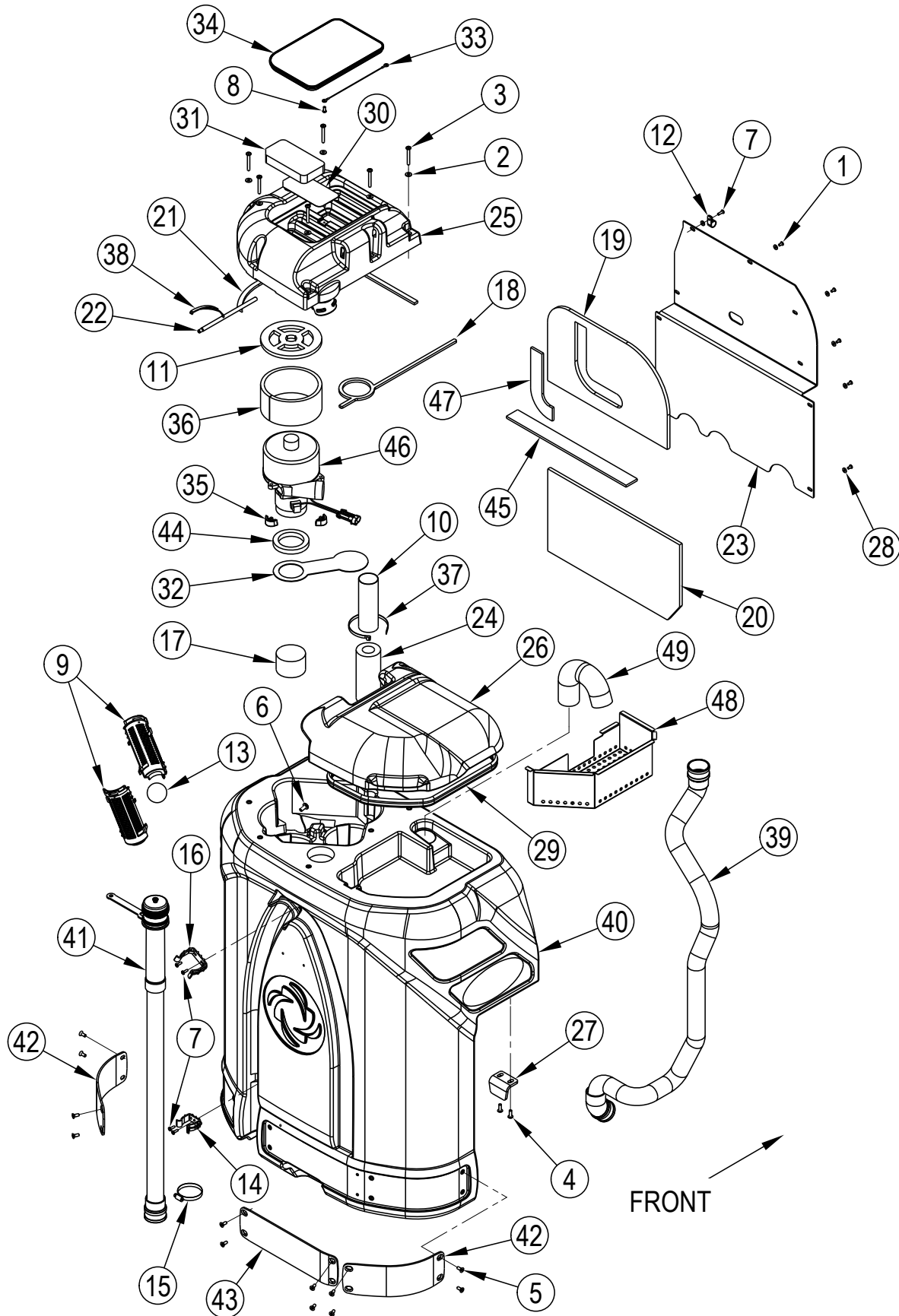

Item	Ref. No.	Qty	Description
1	56002043	8	Scr, Pan Phil 10-24 x .38
2	56002098	7	Wsh, Flt SAE 1/4
3	56002108	6	Scr, Pan Phil 1/4-20 x 2.00
4	56002507	4	Scr, Pan Phil 1/4-20 x .75
5	56002760	12	Scr, Flt Phil 1/4-20 x .62
6	56002793	1	Scr, Pan Phil 5/16-18 x .75
7	56002896	5	Scr, Pan Phil SS 10-24 x .62
8	56009191	2	Scr, Pan Phil Plastite 10-14 x .50
9	56324497	2	Cage, Float
10#	56385599	1	Hose 2 X 8 E00191
11	56314704	1	Gasket
12	56385564	1	Clamp, P
13	56391690	1	Ball, Float
14	56407361	1	Clamp, Plastic
15	56440213	3	Clamp, Hose SAE #32
16	56212236	1	Clamp, Plastic
17	56314098	2	Foam Cylinder
18	56314099	1	Gasket
19	56314100	1	Muffler, Top Panel
20	56314101	1	Muffler, Bottom Panel
21	56314103	1	Gasket
22	56314115	1	Pin, Cover Pivot
23#	56382619	1	Cover Exhaust
24	56391807	1	Foam, Acoustical
25	56314201	1	Cover, Vac Motor
26	56314203	1	Lid, Recovery
27	56314220	2	Tank Mount Bracket
28	56001954	9	Wsh, Flt SAE #10
29	56314371	1	Gasket
30	56314372	1	Screen, Filter
31	56314373	1	Filter
32	56314376	1	Plate, Separator
33	56314400	1	Wire Rope, 9 Inch
34	56109539	1	Lid, Vac Filter
35	56314484	3	Mount, Vibration
36	56314488	1	Muffler, Vac
37	56477613	1	Tie, Cable
38	56314509	1	Spring
39	56390862	1	Vac Hose Assy.
40	56390832	1	Tank, Recovery
41	56381921	1	Drainhose
[]	56601411	1	Drain Hose Cap Kit
[]	56601410	1	Drain Hose Extension
42	56314639	2	Bumper, Rear
43	56314656	1	Bumper, Rear Middle
44	56314760	1	Gasket, Vacuum Duct
45	56314706	1	Foam, Sound
46	56397228	1	Motor, Vac 36VDC (M5)
[]	56212223	1	Carbon Brush Set
[]	56314251	1	Harness, Vac
47	56314705	1	Foam, Sound
48	56109695	1	Strainer Basket
49	56390848	1	Formed Hose

[] = Not Shown

= Revised or new since last update

FRONT

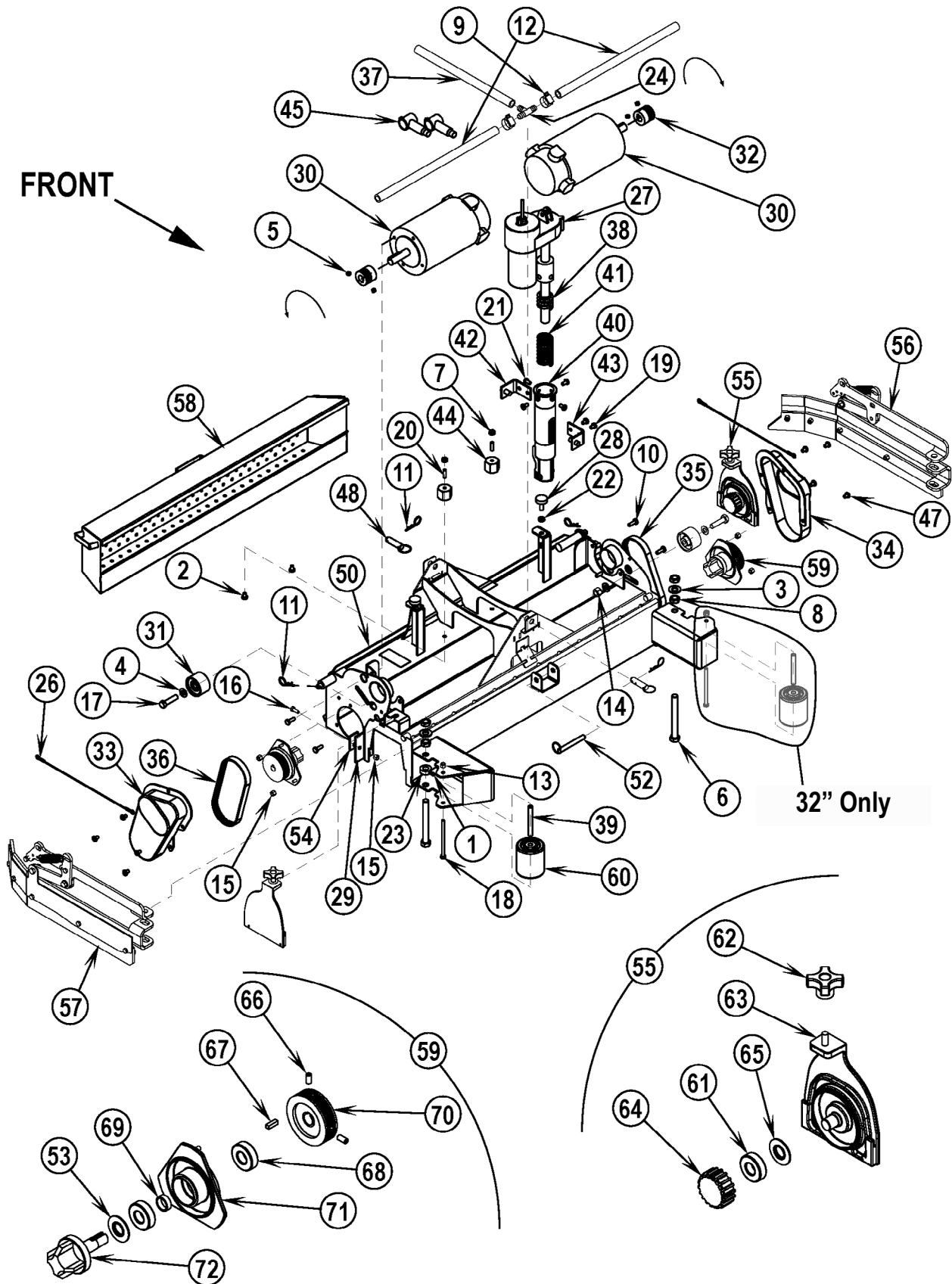

Item	Ref. No.	Qty	Description	Item	Ref. No.	Qty	Description
1	56001841	2	Scr, Soc Set Loc 1/4-20 x .25	35	56407465	1	Belt, Poly V 180J6
2	56001861	2	Scr, Hex Hd 1/4-20 x .38	36	56407466	1	Belt, Poly V 190J6
3	56001879	2	Wsh, Flt SAE 1/2	37	56409462	1	Hose, Spiral
4	56002063	4	Wsh, Flt SAE 3/8	38	56412071	1	Compression Spring
5	56002086	4	Scr, Soc Set Loc 5/16-18 x .25	39	56412176	1	Bushing (qty of 2 on 32")
6	56002484	2	Scr, Hex Hd 1/2-13 x 4.50	40	56412262	1	Housing, Spring
7	56002561	2	Nut, Hex W/ Shprf 1/4-20	41	56420018	1	Compression Spring
8	56002843	4	Nut, Hex Nyl Loc-Thin 1/2-13	42	56420019	1	Nut Retainer
9	56112771	2	Clamp, Hose	43	56420020	1	Nut Retainer
10	56002948	6	Scr, Hex Hd Loc 1/4-20 x .75	44	56469858	2	Standoff, Insulated
11	56002959	4	Pin, Cotter Hair	45	56493357	2	Insulator, Terminal
12	56316553	2	Manifold, PVC 28	47	56003603	8	Scr, Pan Phil Thd Form 1/4-20 x .38
	56316552	2	Manifold, PVC 32	48	56003671	2	Pin, Ring .50 x 1.25
13	56003403	1	Nut, Hex Nyl Loc M6-1.00 (qty of 2 on 32")	49	NA	1	Accessory Plate Data Plate
14	56003406	2	Nut, Hex Nyl Loc M10-1.50	50	56316570	1	Housing Weld't, 28"
15	56003426	8	Nut, Hex Nyl Loc SS M6 x 1.0		56316571	1	Housing Weld't, 32"
16	56003431	2	Scr, Hex Hd SS M6-1.0 x 16mm	51	56314254	1	Harness, Brush Motor (Not Shown)
17	56003491	2	Scr, Hex M10-1.50 x 40mm	52	56314294	1	Pin, Hitch Cotterless
18	56003492	1	Scr, Hex M6-1.0 x 95mm (qty of 2 on 32")	53	56407558	1	Washer, Bearing
19	56009019	2	Scr, Hex Thd Form 1/4-20 x .38	54	56314436	2	Strap
20	56009020	2	Stud	55	56314445	2	Idler End Assy (61-65)
21	56009062	4	Scr, Pan Phil Thd Form 1/4-20 x .50	56	56314648	1	Left Skirt Assy NOTE 2
22	56009086	4	Nut, Hex Jam 5/16-18	57	56314649	1	Right Skirt Assy NOTE 2
23	56152811	2	Collar	58	56397442	1	Hopper Weld't, 28"
24	56262549	1	Tee, Barb		56397443	1	Hopper Weld't, 32"
26	56330391	2	Wire Rope, 12 Inch	59	56407559	2	Drive End Assy (53, 66-72)
27	56393303	1	Lift Actuator, Brush (M1)	60	56412459	1	Wheel (qty of 2 on 32")
[]	56388520	1	Plastic Nut	61	56106070	1	Bearing, Ball
28	56401783	2	Leveler	62	56407303	1	Knob
29	56407391	2	Blade	63	56315447	1	Idler Bearing Plate
30	56407431	2	Motor, 36VDC, .75HP (M7 & M8)	64	56407551	1	Hub
[]	56407489	1	Armature	65	56407558	1	Washer, Bearing
[]	56410183	1	Bearing	66	56002119	2	Scr, Soc Set Loc 1/4-20 x .50
[]	56407492	1	Brush Cap Assy	67	56003237	1	Key, Sq. .19 x .62
[]	56407493	4	Carbon Brush Assy	68	56106070	2	Bearing, Ball
[]	56407494	4	Brush Cover Cap	69	56407389	1	Spacer
31	56407432	2	Idler, Belt	70	56407442	1	Sheave, Poly-V
32	56407433	2	Sheave, Poly-V	71	56381765	1	Bearing Plate
33	56407434	1	Guard, Right Belt	72	56109527	1	Spindle
34	56407435	1	Guard, Left Belt				

[] = Not Shown

NOTE: See "BRUSH SELECTOR GUIDE" at back of manual for available scrub brushes.

NOTE 2: See "SKIRT ASSEMBLIES-CYLINDRICAL".

FRONT

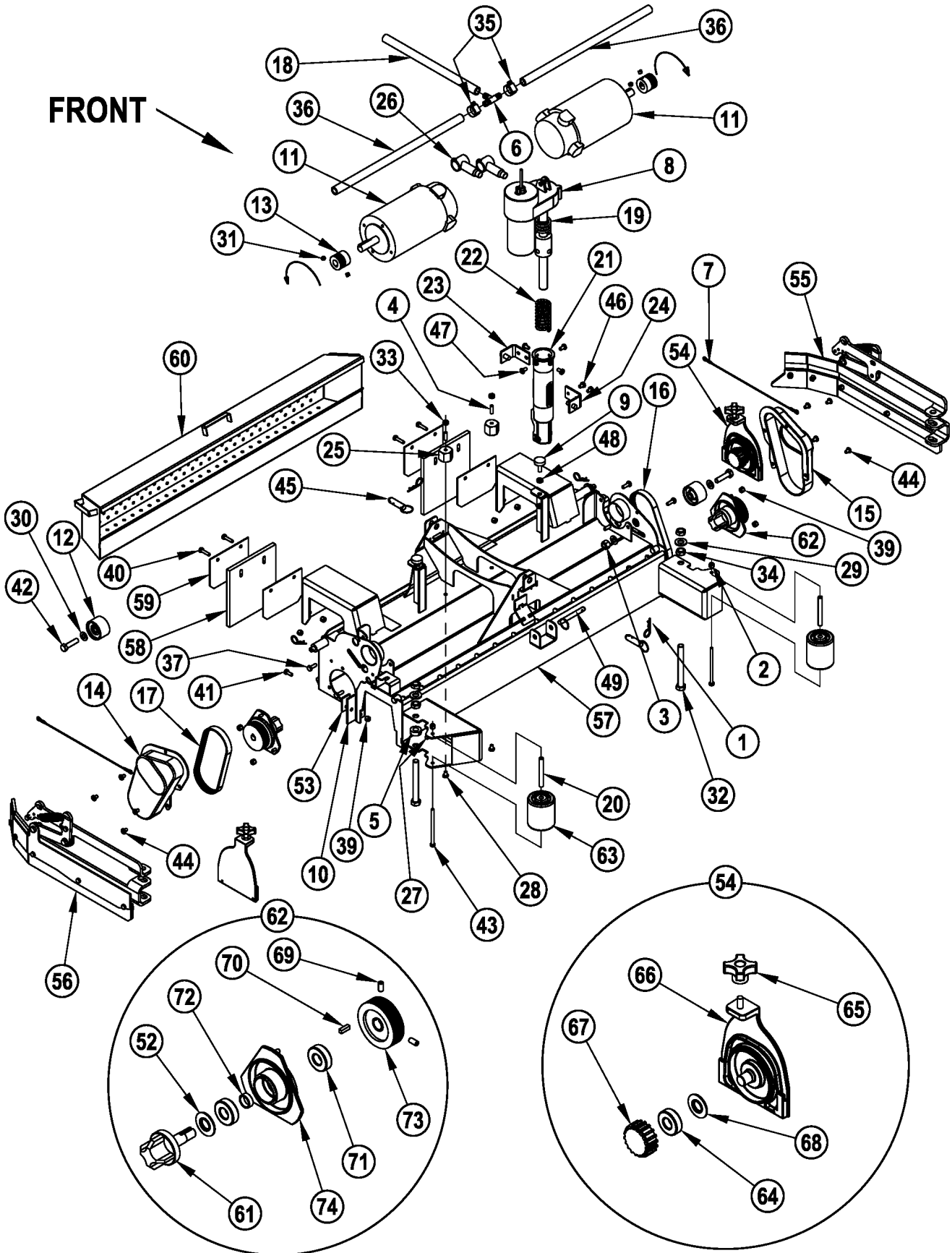

Item	Ref. No.	Qty	Description	Item	Ref. No.	Qty	Description
1	56002959	4	Pin, Cotter Hair	35	56112771	2	Clamp, Hose SAE #10
2	56003403	2	Nut, Hex Nyl Loc M6-1.00	36	56316551	2	Manifold, PVC 35
3	56003406	2	Nut, Hex Nyl Loc M10-1.50		56316550	2	Manifold, PVC 38
4	56009020	2	Stud	37	56002948	6	Scr, Hex Hd Loc 1/4-20 x .75
5	56152811	2	Collar	39	56003426	12	Nut, Hex Nyl Loc SS M6 x 1.0
6	56262549	1	Tee, Barb	40	56003430	4	Scr, Hex Hd SS 6-1.0 x 25mm
7	56330391	2	Wire Rope, 12 Inch	41	56003431	2	Scr, Hex Hd SS M6-1.0 x 16mm
8	56393303	1	Actuator, Motor (M1)	42	56003491	2	Scr, Hex M10-1.50 x 40mm
[]	56388520	1	Plastic Nut	43	56003492	2	Scr, Hex M6-1.0 x 95mm
9	56401783	2	Leveler	44	56003603	8	Scr, Pan Phil Thd Form 1/4-20 x .38
10	56407391	2	Blade	45	56003671	2	Pin, Ring .50 x 1.25
11	56407431	2	Motor, 36VDC, .75 HP (M7 & M8)	46	56009019	2	Scr, Hex Thd Form 1/4-20 x .38
[]	56407489	1	Armature	47	56009062	4	Scr, Pan Phil Thd Form 1/4-20 x .50
[]	56410183	1	Bearing	48	56009086	4	Nut, Hex Jam 5/16-18
[]	56407492	1	Brush Cap Assy	49	NA	1	Accessory Plate Data Plate
[]	56407493	4	Carbon Brush Assy	50	56314254	1	Harness, Brush Motor (Not Shown)
[]	56407494	4	Brush Cover Cap	51	56314294	1	Pin, Hitch Cotterless
12	56407432	2	Idler, Belt	52	56407558	1	Washer, Bearing
13	56407433	2	Sheave, Poly-V	53	56314436	2	Strap
14	56407434	1	Guard, Right Belt	54	56314445	2	Idler End Assy (64-68)
15	56407435	1	Guard, Left Belt	55	56314648	1	Left Skirt Assy NOTE 3
16	56407465	1	Belt, Poly V 180J6	56	56314649	1	Right Skirt Assy NOTE 3
17	56407466	1	Belt, Poly V 190J6	57	56316572	1	Housing Weld't 35"
18	56409462	1	Hose, Spiral		56316573	1	Housing Weld't 38"
19	56412071	1	Compression Spring	58	56314860	1	Kit, Deck Blade Cyl Red Gum Rubber (Standard) NOTE 2
20	56412176	2	Bushing		56390791	1	Kit Cyl Blade Gum NOTE 2
21	56412262	1	Housing, Spring	59	56314867	4	Strap
22	56420018	1	Compression Spring	60	56314870	1	Hopper Weld't-35
23	56420019	1	Nut Retainer		56314869	1	Hopper Weld't-38
24	56420020	1	Nut Retainer	61	56109527	1	Spindle
25	56469858	2	Standoff, Insulated	62	56407559	2	Drive End Assy (52, 61, 69-74)
26	56493357	2	Insulator, Terminal	63	56412459	2	Wheel
27	56001841	2	Scr, Soc Set Loc 1/4-20 x .25	64	56106070	1	Bearing, Ball
28	56001861	2	Scr, Hex Hd 1/4-20 x .38	65	56407303	1	Knob
29	56001879	2	Wsh, Flt SAE 1/2	66	56315447	1	Idler Bearing Plate
30	56002063	4	Wsh, Flt SAE 3/8	67	56407551	1	Hub
31	56002086	4	Scr, Soc Set Loc 5/16-18 x .25	68	56407558	1	Washer, Bearing
32	56002484	2	Scr, Hex Hd 1/2-13 x 4.50	69	56002119	2	Scr, Soc Set Loc 1/4-20 x .50
33	56002561	2	Nut, Hex W/ Shprf 1/4-20	70	56003237	1	Key, Sq. .19 x .62
34	56002843	4	Nut, Hex Nyl Loc-Thin 1/2-13	71	56106070	2	Bearing, Ball
				72	56407389	1	Spacer
				73	56407442	1	Sheave, Poly-V
				74	56381765	1	Bearing Plate

[] = Not Shown

NOTE 1: See "BRUSH SELECTOR GUIDE" at back of manual for available scrub brushes.

NOTE 2: Deck Blade Kits include two (item 58) Blades and two blades for use in Skirt Assemblies (items 55 & 56).

NOTE 3: See "SKIRT ASSEMBLIES-CYLINDRICAL".

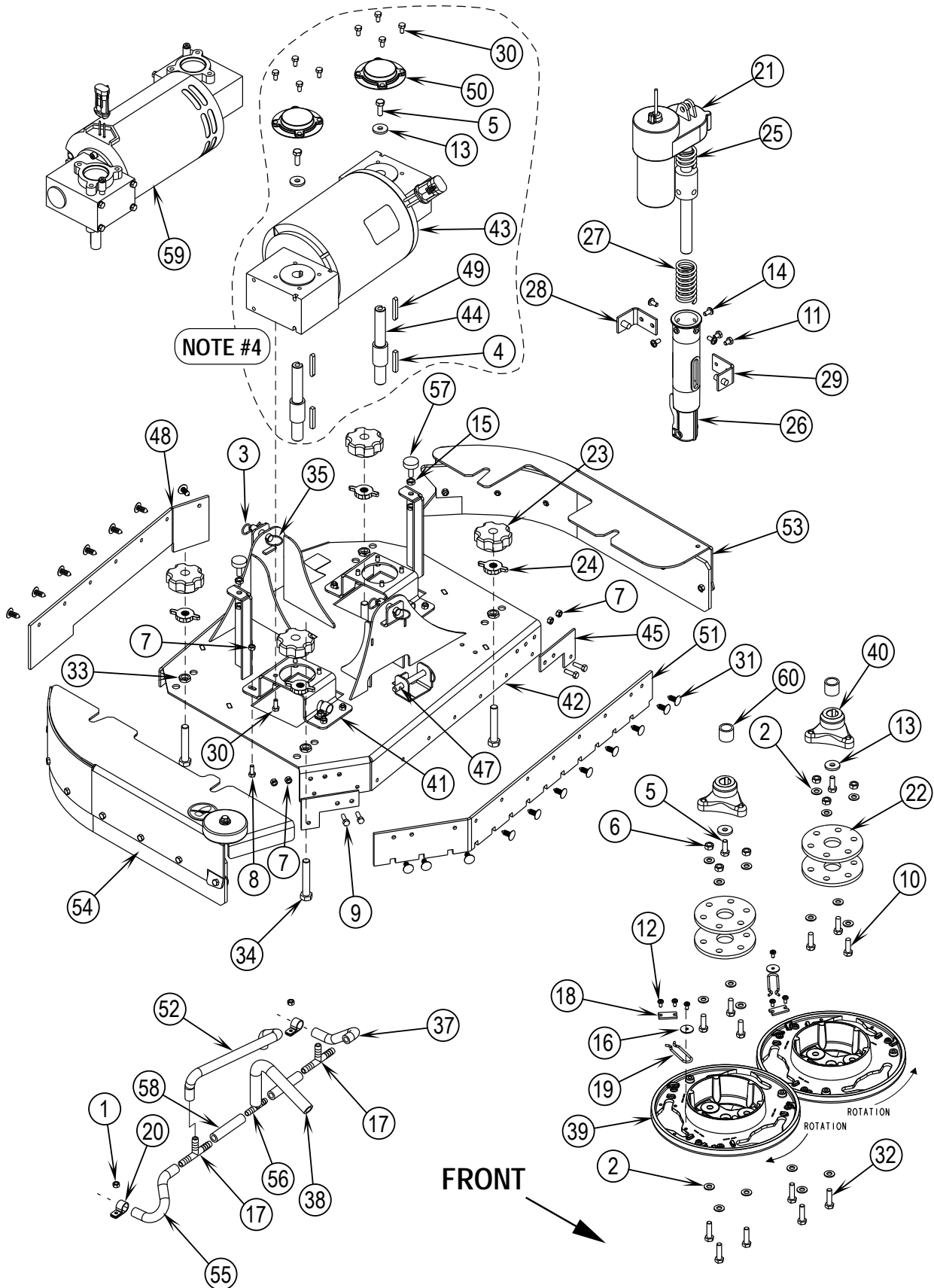

Item	Ref. No.	Qty	Description	Item	Ref. No.	Qty	Description
1	56002768	2	Nut, Hex Nyl Loc 10-24	43	56314141	1	Motor Gearbox Assy (28")
2	56002938	18	Wsh, Flt SAE SS 5/16		56314335	1	Motor Gearbox Assy (32") NOTE 4
3	56002959	4	Pin, Cotter Hair				
4	56003246	2	Key, Sq .25 x 1.62 NOTE 4	[]	56314359	2	Key, 6mm Square
**	56315722	1	Kit, Gum Rubber NOTE 3	[]	56314499	2	Cover, Gearbox
**	56315721	1	Kit, Red Gum Rubber NOTE 3	[]	56314560	2	Gearbox
5	56003335	2	Scr Hex Loc SS 5/16-18 x .88 NOTE 3	[]	56314580	1	Bearing (Fan End)
6	56003405	6	Nut, Hex Nyl Loc SS M8 x 1.25	[]	56412323	1	Bearing (Brush End)
7	56003426	12	Nut, Hex Nyl Loc SS M6 x 1.0	[]	56314582	1	Brush Ring
8	56003431	8	Scr, Hex Hd SS M6-1.0 x 16mm	[]	56314583	4	Carbon Brush
9	56003443	4	Scr, Hex Hd SS M6-1.00 x 20mm (28")	[]	56314584	1	Safety Hook
10	56003477	6	Scr, Hex Loc SS M8-1 x 25mm	44	56314218	2	Shaft, Hub Mount NOTE 4
11	56009019	2	Scr, Hex Thd Form 1/4-20 x .38	45	56314261	2	Skirt Bracket, Forward (28")
12	56009030	6	Scr, Pan Phil Thd Form 10-24 x .38	46	56315705	2	Spacer NOTE 3
13	56009057	2	Wsh, Flt Harden .344 x 1.000x.120/.135 NOTE 3	47	56314294	1	Pin, Hitch Cotterless
14	56009062	4	Scr, Pan Phil Thd Form 1/4-20 x .50	48	-		See Disk Deck Blade Kits below
15	56009086	4	Nut, Hex Jam 5/16-18	49	56314359	2	Key, 6mm Sq NOTE 4
16	56009096	2	Wsh, Flt .193 x .875 x .060	50	56314499	2	Cover, Gearbox NOTE 4
17	56249280	2	Tee, Barb	51	-		See Disk Deck Blade Kits below
18	56366455	2	Plate, Stop	52	56412189	1	Hose, Spiral .375
19	56366463	2	Spring Retainer	53	56314897	1	Skirt Assy Left 28" NOTE 6
20	56385564	2	Clamp, P		56314898	1	Skirt Assy Left 32" NOTE 6
21	56393303	1	Actuator, Motor (M1)	54	56314896	1	Skirt Assy Right NOTE 6
[]	56388520	1	Plastic Nut	55	56392277	1	Tube, Solution
22	56407053	4	Thermoid Disk	56	56397300	1	Tee, Barb
23	56380149	4	Knob TSBUS2010-1060	57	56401783	2	Leg Leveler 5/16-18
24	56601578	4	Knob	58	56412187	2	Hose, Spiral, .375
25	56412071	1	Compression Spring	59	56315704	1	Gearbox Assy (32"/ M7) NOTE 3
26	56412262	1	Housing, Spring	[]	56315711	2	Gearbox
27	56420018	1	Compression Spring				
28	56420019	1	Nut Retainer				
29	56420020	1	Nut Retainer				
30	56003211	16	Scr, Hex Hd SS M6-1.0 x 12mm NOTE 4				
	56002885	6	Scr, Hex SS 3/8-16 x .75 NOTE 3	**	56314913	1	Kit, Gum Rubber 28 Disk NOTE 2
31	56003263	18	Rivet, Nylon Tree Push-In (.25)		56314917	1	Kit, Red Gum Rubber 28 Disk (Standard) NOTE 2
32	56003639	6	Scr, Hex Hd SS M8-1.25 x 30mm	**	56390967	1	Blade Kit-Disk PU NOTE 2
33	56003657	4	Nut Hex Jam SS M12-1.75				
34	56003658	4	Scr Hex Thd To Hd SS M12-1.75 x 70mm				
35	56003671	2	Pin, Ring .50 x 1.25				
37	56249682	1	Tube, Solution				
38	56262180	1	Tube Spiral .375				
39	56314030	2	Brush Holder				
40	56314108	2	Hub, Drive				
41	56314053	2	Bracket, Motor NOTE 4				
	56315701	2	Bracket, Motor NOTE 3				
42	56314081	1	Weld't, Disk Deck 28"				
	56314090	1	Weld't, Disk Deck 32"				

28" Disk Deck Blade Kit

**	56314913	1	Kit, Gum Rubber 28 Disk NOTE 2
	56314917	1	Kit, Red Gum Rubber 28 Disk (Standard) NOTE 2
**	56390967	1	Blade Kit-Disk PU NOTE 2

32" Disk Deck Blade Kit

**	56314914	1	Kit, Gum Rubber 32 Disk NOTE 2
	56314918	1	Kit, Red Gum Rubber 32 Disk (Standard) NOTE 2

[] = Not Shown

** = Optional

NOTE 1: See "BRUSH SELECTOR GUIDE" at back of manual for available scrub brushes.

NOTE 2: These Disk Deck Blade Kits include the mounting fasteners (Rivet, Nylon Tree Push-In 56003263 item 31), the two blades (items 51 & 59) and two blades for use in Skirt Assemblies (items 53 & 54).

NOTE 3: Only used on 32" models.

NOTE 4: Used on all 28" models.

NOTE 6: See "SKIRT ASSEMBLIES-DISK (28", 32)".

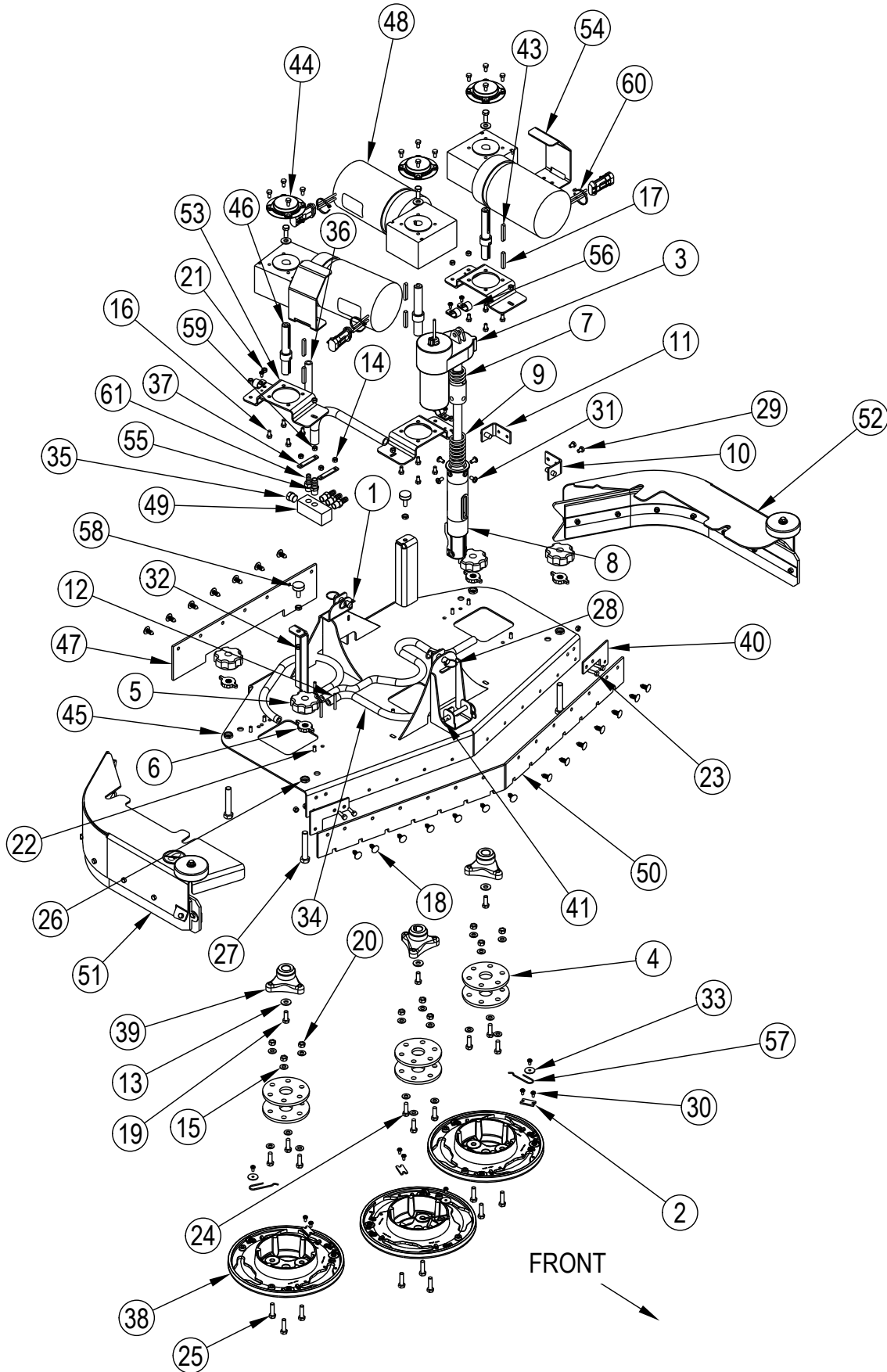

Item	Ref. No.	Qty	Description	Item	Ref. No.	Qty	Description
1	56002959	2	Pin, Cotter Hair	36	56302015	1	Hose, Spiral .375
2	56366455	3	Plate, Stop	37	56304601	2	Plate
3	56393303	1	Actuator, Motor (M1)	38	56314030	3	Brush Holder
*	56388520	1	Plastic Nut	39	56314108	3	Hub, Drive
4	56407053	6	Thermoid Disk	40	56314261	2	Skirt Bracket, Forward (38")
5	56380149	4	Knob TSBUS2010-1060	41	56314294	1	Pin, Hitch Cotterless
6	56601578	4	Knob	42	56900034	4	Barb, Adapter 3/8 X 1/4NPT
7	56412071	1	Compression Spring	43	56314359	3	Key, 6mm Sq
8	56412262	1	Housing, Spring	44	56314499	3	Cover, Gearbox
9	56420018	1	Compression Spring	45	56314683	1	Weldment, Deck
10	56420019	1	Nut Retainer	46	56314687	3	Shaft, Hub Mount
11	56420020	1	Nut Retainer	47	-		See Disk Deck Blade Kits below
12	56002020	4	Scr, Pan Phil 10-24 x 1.75	48	56314789	3	Motor Gearbox Assembly (M7, M8, M10)
13	56002220	6	Wsh, Flt Std 5/16	[]	56314785	A/R	Gearbox, Replacement
14	56002768	4	Nut, Hex Nyl Loc 10-24	[]	56314784	A/R	Motor, Replacement
15	56002938	18	Wsh, Flt SAE SS 5/16	[]	56314786	A/R	Kit, Carbon Brush (1 kit per motor)
16	56003211	24	Scr, Hex Hd SS M6-1.0 x 12mm	49	56314790	1	Manifold, Solution
17	56003246	3	Key, Sq .25 x 1.62	50	-		See Disk Deck Blade Kits below
18	56003263	21	Rivet, Nylon Tree Push-In (.25)	51	56314820	1	Skirt Assembly Right NOTE 4
19	56003335	6	Scr Hex Loc SS 5/16-18 x .88	52	56314821	1	Skirt Assembly Left NOTE 4
20	56003405	9	Nut, Hex Nyl Loc SS M8 x 1.25	53	56314868	3	Bracket, Motor
21	56003426	13	Nut, Hex Nyl Loc SS M6 x 1.0	54	56314902	2	Bracket, Motor Guard
22	56003431	9	Scr, Hex Hd SS M6-1.0 x 16mm	55	56373456	1	Barb, Adapter 1/2 x 1/4NPT
23	56003443	4	Scr, Pan Phil M6-1.00 x 20mm (38")	56	56385564	4	Clamp, P
24	56003477	9	Scr, Hex Loc SS M8-1 x 25mm	57	56397081	3	Spring Retainer
25	56003639	9	Scr, Hex Hd SS M8-1.25 x 30mm	58	56401783	2	Leg Leveler 5/16-18
26	56003657	4	Nut Hex Jam SS M12-1.75	59	56409462	1	Hose, Spiral .500
27	56003658	4	Scr Hex Thd To Hd SS M12-1.75 x 70mm	60	56478246	3	Tie, Cable
28	56003671	2	Pin, Ring .50 x 1.25				35" Disk Deck Blade Kit
29	56009019	2	Scr, Hex Thd Form 1/4-20 x .38				Kit, Red Gum Rubber 35 Disk (Standard) NOTE 2
30	56009030	13	Scr, Pan Phil Thd Form 10-24 x .38	56314846	1		Blade Kit-Disk PU NOTE 2
31	56009062	4	Scr, Pan Phil Thd Form 1/4-20 x .50	**	56390927	1	38" Disk Deck Blade Kits
32	56009086	4	Nut, Hex Jam 5/16-18				Kit, Red Gum Rubber 38 Disk (Standard) NOTE 2
33	56009096	3	Wsh, Flt .193 x .875 x .060	56314848	1		Blade Kit-DiskGum NOTE 2
34	56391771	3	Hose, Spiral .375	**	56390796	1	
35	56261421	1	Plug, Hex Pipe				

[] = Not Shown

** = Optional

NOTE 1: See "BRUSH SELECTOR GUIDE" at back of manual for available scrub brushes.

NOTE 2: These Disk Deck Blade Kits include the mounting fasteners (Rivet, Nylon Tree Push-In 56003263 item 18), the two blades (items 47 & 50) and two blades for use in Skirt Assemblies (items 51 & 52).

NOTE 4: See "SKIRT ASSEMBLIES-DISK (35", 38)".

56314648-LEFT SKIRT ASSEMBLY

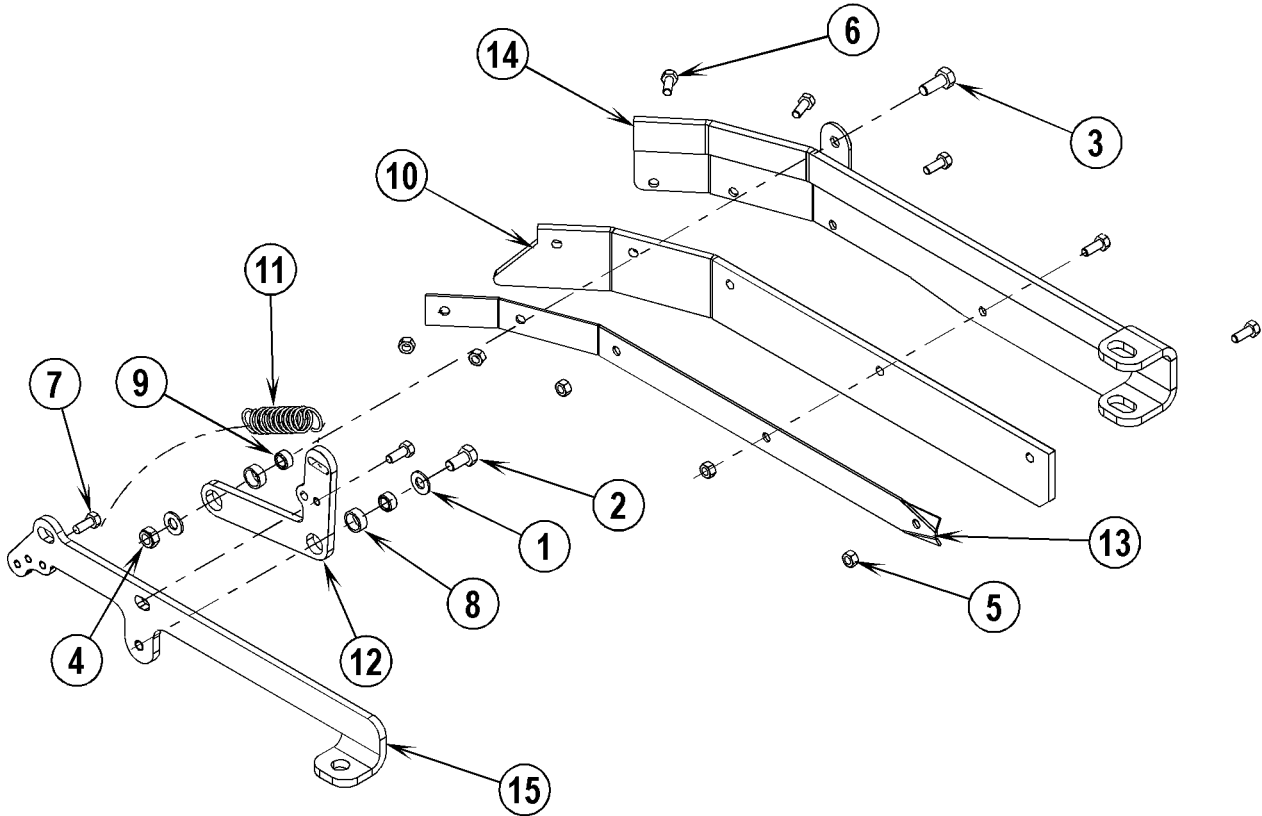

56314649-RIGHT SKIRT ASSEMBLY

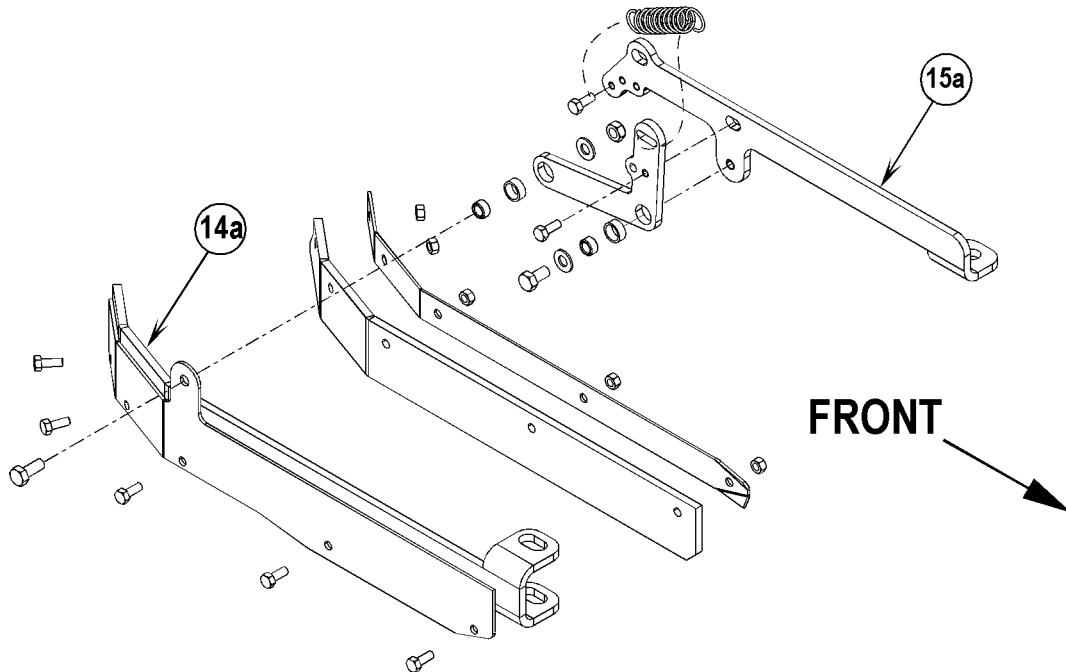

Item	Ref. No.	Qty	Description
	56314648	1	Left Skirt Assembly
	56314649	1	Right Skirt Assembly
1	56001939	2	Wsh, Flt SAE 5/16
2	56003178	1	Scr, Hex M8-1.25 x 16mm
3	56003179	1	Scr, Hex Thd To Hd M8-1.25 x 20mm
4	56003389	1	Nut, Hex Nyl Loc M8-1.25
5	56003426	5	Nut, Hex Nyl Loc SS M6-1.00
6	56003431	6	Scr, Hex Hd SS M6-1.00 x 16mm
7	56003441	1	Scr, Hex Nyl Loc M6-1.00 x 15mm
8	56185263	2	Bearing, Sleeve
9	56320595	2	Bushing, .32 x .50 x .28
10	56410335	1	Skirt, Red Gum Rubber (Standard)
**	56407447	1	Skirt, Gum Rubber
	56314860	1	Kit, Deck Blade Cyl Red Gum Rubber (Standard) NOTE 2
**	56390791	1	Kit Cyl Blade Gum NOTE 2
11	56470672	1	Spring, Extension
12	56314435	1	Arm, Mount
13	56314437	1	Retainer, Skirt
14	56314439	1	Skirt Bracket Weld't, Left
14a	56314438	1	Skirt Bracket Weld't, Right
15	56314440	1	Bracket, Mount, Left
15a	56314441	1	Bracket, Mount, Right

** = Optional

NOTE: All quantities are for one skirt assembly only, there are two skirt assemblies on the machine.

NOTE 2: For use on 35" and 38" decks. Deck Blade Kits include two (item 10) Blades and two Deck Blades (item 58) in "Scrub System-Cylindrical (35", 38)".

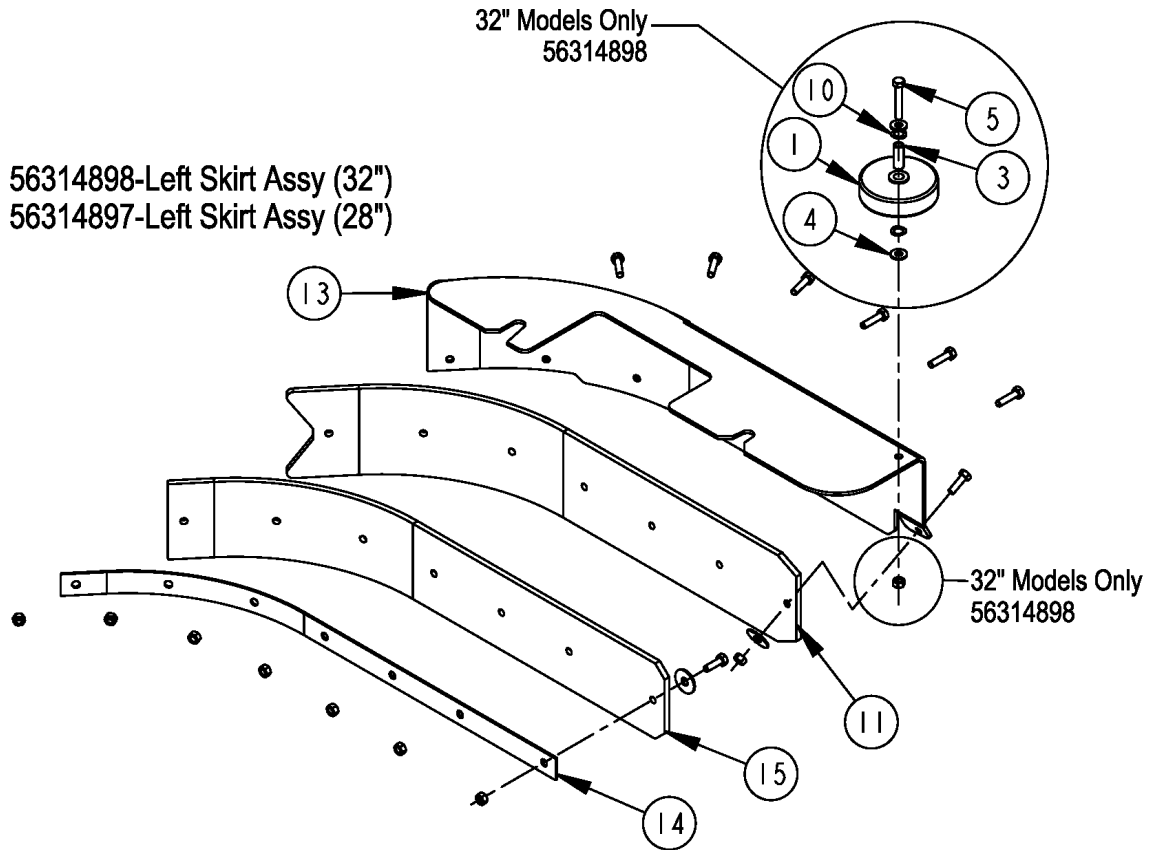

56314896-Left Skirt Assy (28", 32")

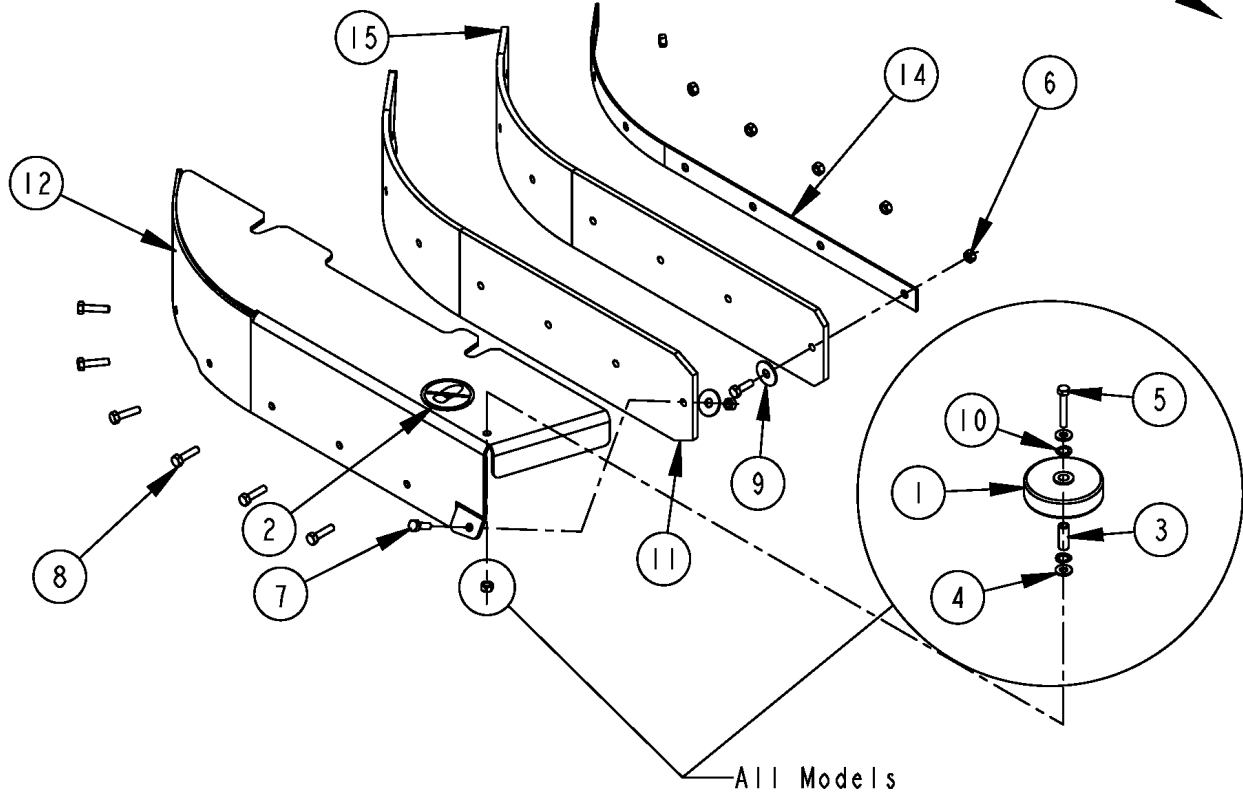

Item	Ref. No.	Qty	Description
	56314898	1	Skirt Assembly Left (32")
	56314897	1	Skirt Assembly Left (28")
	56314896	1	Skirt Assembly Right (28" / 32")
1	56324499	1	Wheel 3.00 NOTE 1
2	56016163	1	Decal, No Step (Right Skirt Assembly only)
3	56471220	1	Bushing NOTE 1
4	56002098	2	Wsh, Flt SAE 1/4 NOTE 1
5	56003167	1	Scr,Hex M6-1.0x40mm NOTE 1
6	56003426	9	Nut, Hex Nyl Loc SS M6 x 1.0 (qty of 8 on 56314897)
7	56003454	2	Scr Hex Thd To Hd SS M6-1.0 x 20mm
8	56003693	6	Scr Hex Thd To Hd SS M6-1.0 x 25mm
9	56003696	2	Wsh, Flt SS .33 x 1.00 x .060
10	56009045	2	Wsh, Bowed .375 x .578 x .060 NOTE 1
11	-		See Disk Deck Blade Kits below
12	56314888	1	Frame, Skirt RH
13	56314889	1	Frame, Skirt LH
14	56314891	1	Retainer, Blade
15	-		See Disk Deck Blade Kits below
			28" Disk Deck Blade Kits
**	56314913	1	Kit, Gum Rubber 28 Disk NOTE 3
	56314917	1	Kit, Red Gum Rubber 28 Disk (Standard) NOTE 3
**	56390967	1	Blade Kit-Disk PU NOTE 3
**	56315722	1	Kit, Gum Rubber NOTE 4
**	56315721	1	Kit, Red Gum Rubber NOTE 4
			32" Disk Deck Blade Kits
**	56314914	1	Kit, Gum Rubber 32 Disk NOTE 3
	56314918	1	Kit, Red Gum Rubber 32 Disk (Standard) NOTE 3
**	56315722	1	Kit, Gum Rubber NOTE 4
**	56315721	1	Kit, Red Gum Rubber NOTE 4

** = Optional

NOTE 1: These items are on the Right Skirt Assembly PN 56314896 on all models, but only on the 32" Left Skirt Assembly PN56314898.

NOTE 2: All quantities are for one skirt assembly only, there are two skirt assemblies on the machine.

NOTE 3: These Disk Deck Blade Kits include the mounting fasteners (Rivet, Nylon Tree Push-In 56003263), four skirt blades (items 11 & 15) and the two deck blades (front and rear).

NOTE 4: These Disk Deck Blade Kits include just the blades for use in the two Skirt Assemblies.

56314821-LEFT SKIRT ASSEMBLY

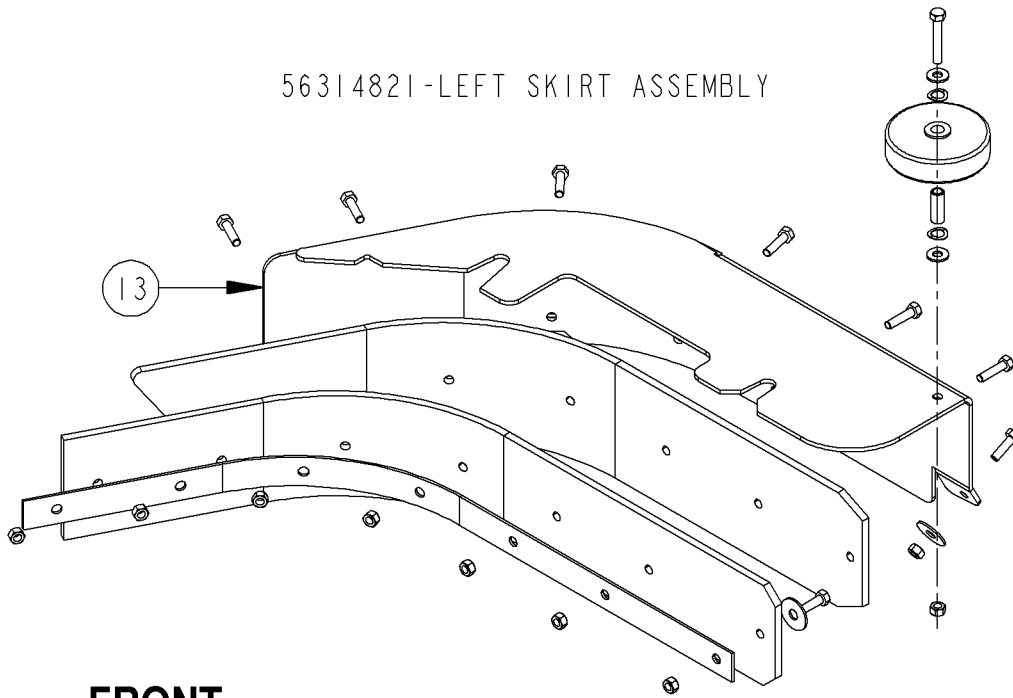

FRONT

56314820-RIGHT SKIRT ASSEMBLY

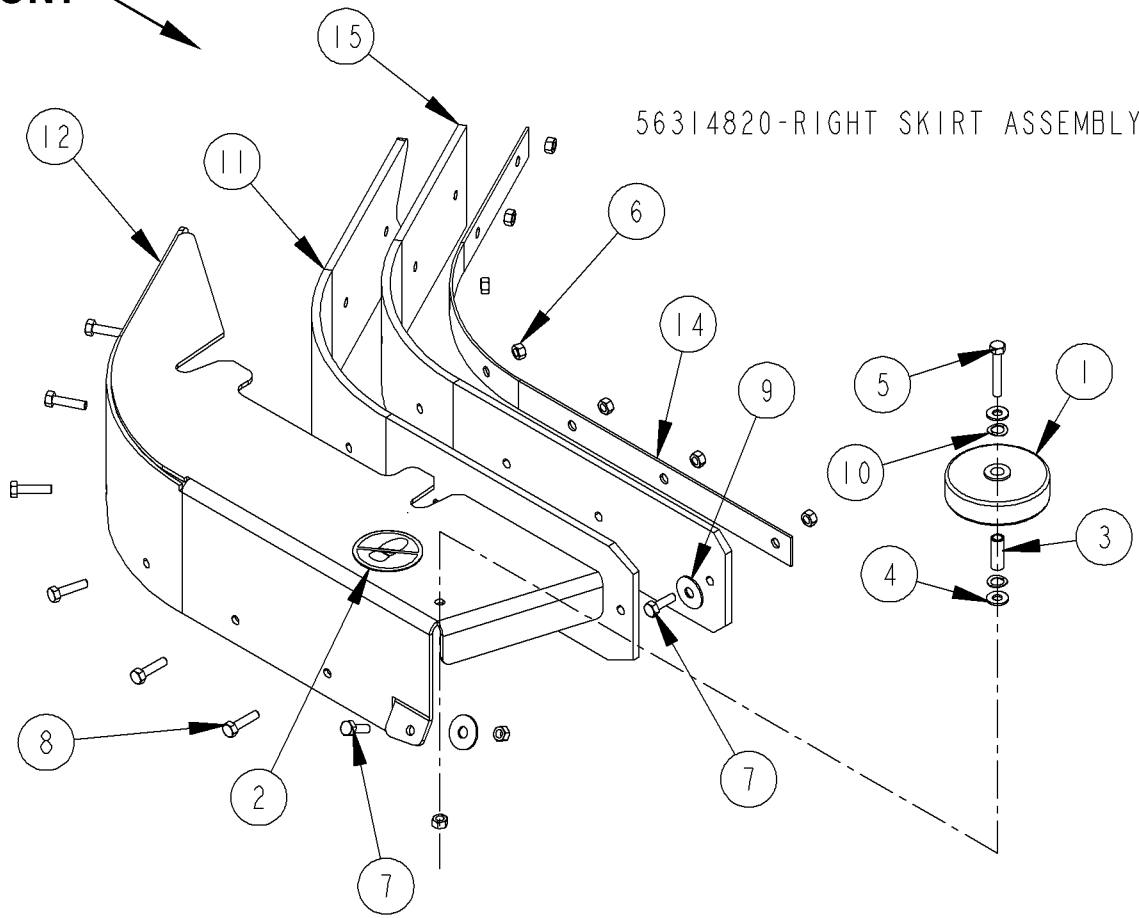

Item	Ref. No.	Qty	Description
	56314821	1	Skirt Assembly Left
	56314820	1	Skirt Assembly Right
1	56324499	1	Wheel 3.00
2	56016163	1	Decal, No Step (Right Skirt Assembly only)
3	56471220	1	Bushing
4	56002098	2	Wsh, Flt SAE 1/4
5	56003167	1	Scr, Hex M6-1.0 x 40mm
6	56003426	9	Nut, Hex Nyl Loc SS M6 x 1.0
7	56003454	2	Scr Hex Thd To Hd SS M6-1.0 x 20mm
8	56003693	6	Scr Hex Thd To Hd SS M6-1.0 x 25mm
9	56003696	2	Wsh, Flt SS .33 x 1.00 x .060
10	56009045	2	Wsh, Bowed .375 x .578 x .060
11	-		See Disk Deck Blade Kits below
12	56314871	1	Frame, Skirt RH
13	56314872	1	Frame, Skirt LH
14	56314873	1	Retainer, Blade
15	-		See Disk Deck Blade Kits below
			35" Disk Deck Blade Kit
	56314846	1	Kit, Red Gum Rubber 35 Disk (Standard) NOTE 1
**	56390927	1	Blade Kit-Disk PU NOTE 1
**	56315720	1	Kit, Red Gum Rubber NOTE 3
			38" Disk Deck Blade Kits
	56314848	1	Kit, Red Gum Rubber 38 Disk (Standard) NOTE 1
**	56390796	1	Blade Kit-DiskGum NOTE 1
**	56315720	1	Kit, Red Gum Rubber NOTE 3
**	56390788	1	Blade Kit-Disk Gum NOTE 3

** = Optional

NOTE 1: These Disk Deck Blade Kits include the mounting fasteners (Rivet, Nylon Tree Push-In 56003263), four skirt blades (items 11 & 15) and the two deck blades (front & rear).

NOTE 2: All quantities are for one skirt assembly only, there are two skirt assemblies on the machine.

NOTE 3: These Disk Deck Blade Kits include just the blades for use in the two Skirt Assemblies.

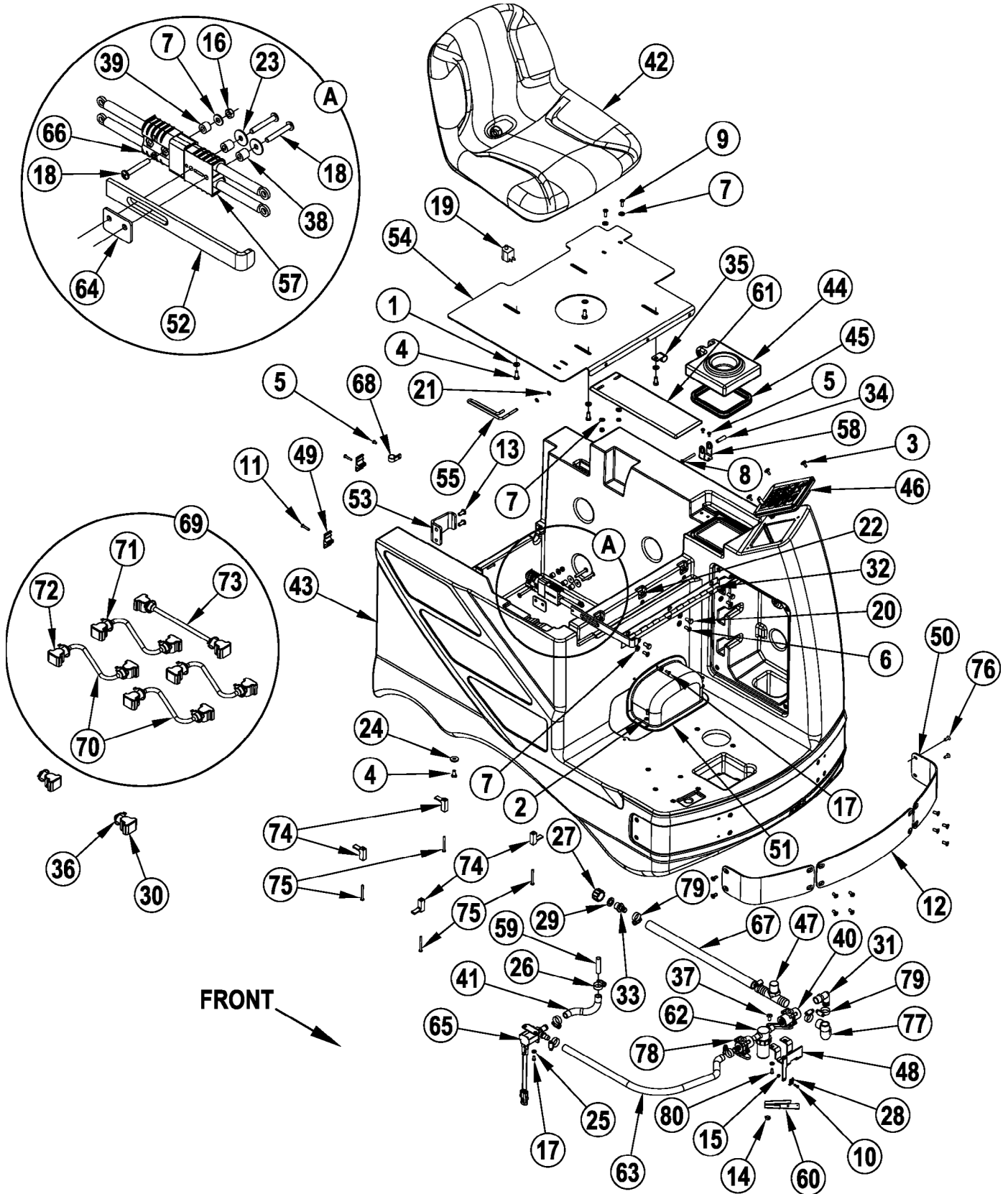

Item	Ref. No.	Qty	Description	Item	Ref. No.	Qty	Description
1	56001939	4	Wsh, Flt SAE 5/16	46	56390780	1	Kit Control Board NOTE 2
2	56001954	3	Wsh, Flt SAE #10	[]	56314713	1	Membrane Switch Assy TSBUS2006-932
3	56009206	4	Scr, Truss Phil-Blk 10-24 x .50	[]	56396188	1	Switch, Key
4	56002035	8	Scr, Hex Hd 5/16-18 x .62	[]	56396189	1	Key, Spare
5	56002043	3	Scr, Pan Phil 10-24 x .38	47	56314758	1	Tee
6	56002066	3	Scr, Pan Phil 1/4-20 x .62	48	56314881	1	Bracket, Water Valve
7	56002098	11	Wsh, Flt SAE 1/4	49	56314155	5	Clamp, Cable
8	56002108	1	Scr, Pan Phil 1/4-20 x 2.00	50	56314638	2	Bumper, Front
9	56002507	2	Scr, Pan Phil 1/4-20 x .75	51	56314975	1	Cover, Actuator Closed
10	56002589	1	Scr, Hex Hd 6-32 x .50	52	56314292	1	Bar, Disconnect
11	56002674	5	Scr, Pan Phil 10-24 x 1.00	53	56316526	1	Tank Mount Bracket
12	56314642	1	Bumper, Front Middle	54	56314988	1	Weld't, Seat Mount
13	56002793	2	Scr, Pan Phil 5/16-18 x .75	55	56314223	1	Prop Rod
14	56002826	1	Nut, Hex Nyl Loc-Thin 5/16-18	56	56390854	1	Harness, Main (Not Shown)
15	56002830	1	Nut, Hex Nyl Loc 6-32	57	56314253	1	Charge Connector Assy
16	56002840	3	Nut, Hex Nyl Loc-Thin 1/4-20	58	56314264	1	Hinge Bracket
17	56002900	5	Scr, Pan Phil SS 10-24 x .50	59	56314904	1	Tube
18	56002997	3	Scr, Pan Phil 1/4-20 x 1.75	60	56314882	1	Bracket, Valve
19	7-82-00050	1	Switch (S2)	61	56314532	1	Panel, Battery Box
20	56003178	3	Scr, Hex M8-1.25 x 16mm	62	56314756	1	Strainer
21	56003268	2	Ring, Ret Ext Type E Reinf. .25 Dia.	63	56386182	1	Hose, Spiral .50ID x 26.00
22	56003389	3	Nut, Hex Nyl Loc M8-1.25	64	56397189	1	Spacer
23	56009002	2	Wsh, Flt .266 x .906 x .060	65	56397215	1	Solenoid Valve Assy, 36V (L1)
24	56009122	4	Wsh, Flt .344 x .938 x .125	66	56397508	1	Charge Connector Assy
25	56009205	4	Wsh, Flt SS #10	67	56263218	1	Hose, .75 Clear PVC
26	56219932	4	Clamp, Hose SAE #6	68	56442003	1	Clamp, P
27	56255076	1	Cap, Pipe GHT Nylon	69	56314339	1	Kit, Battery Connector (includes items 70-73)
28	56344265	1	Clamp, Cable				NOTE 1
29	56368776	1	Washer, Rubber	70	56456460	4	Cable, Battery
30	56372673	2	Boot, Battery Post	71	56478246	10	Tie, Cable
31	56314757	1	Barb, 90 Elbow, 3/4 x 1/2NPT	72	56372673	10	Boot, Battery Post
32	56314973	1	Hinge	73	56441600	1	Cable, Battery
33	56900273	1	Barb	*	56314119	1	Battery Spacer
34	56468553	1	Bushing, .27 x .37 x 1.30	74	56314608	4	Clamp, Cable
35	56469380	1	Clamp, P	75	56002171	4	Scr, Pan Phil 10-24 x 2.00
36	56478246	2	Tie, Cable	76	56002760	12	Scr, Flt Phil 1/4-20 x .62
37	56003003	1	Scr, Pan Phil 5/16-18 x .62	77	56410162	1	Hose, Spiral .75 x 7.00
38	56046309	2	Spacer, Phenolic	78	56314755	1	Valve, Solution
39	56050872	1	Spacer, Phenolic	79	56112771	4	Clamp, Hose SAE #10
40	56314899	1	Valve, Solution	80	56001993	2	Scr, Pan Phil 10-24 x .50
41	56262180	1	Hose, Spiral .50ID x 7.00				[] = Not Shown
42	8-69-00022	1	Seat				
43	56390853	1	Solution Tank				
44	56314066	1	Cover, Solution Tank, Assy				
45	56314069	1	Gasket				

NOTE 1: Battery Connector Kit (56314339) is included with machine.

NOTE 2: 56314665 is OBSOLETE and replaced by 56390780. 56390780 is used on all models.

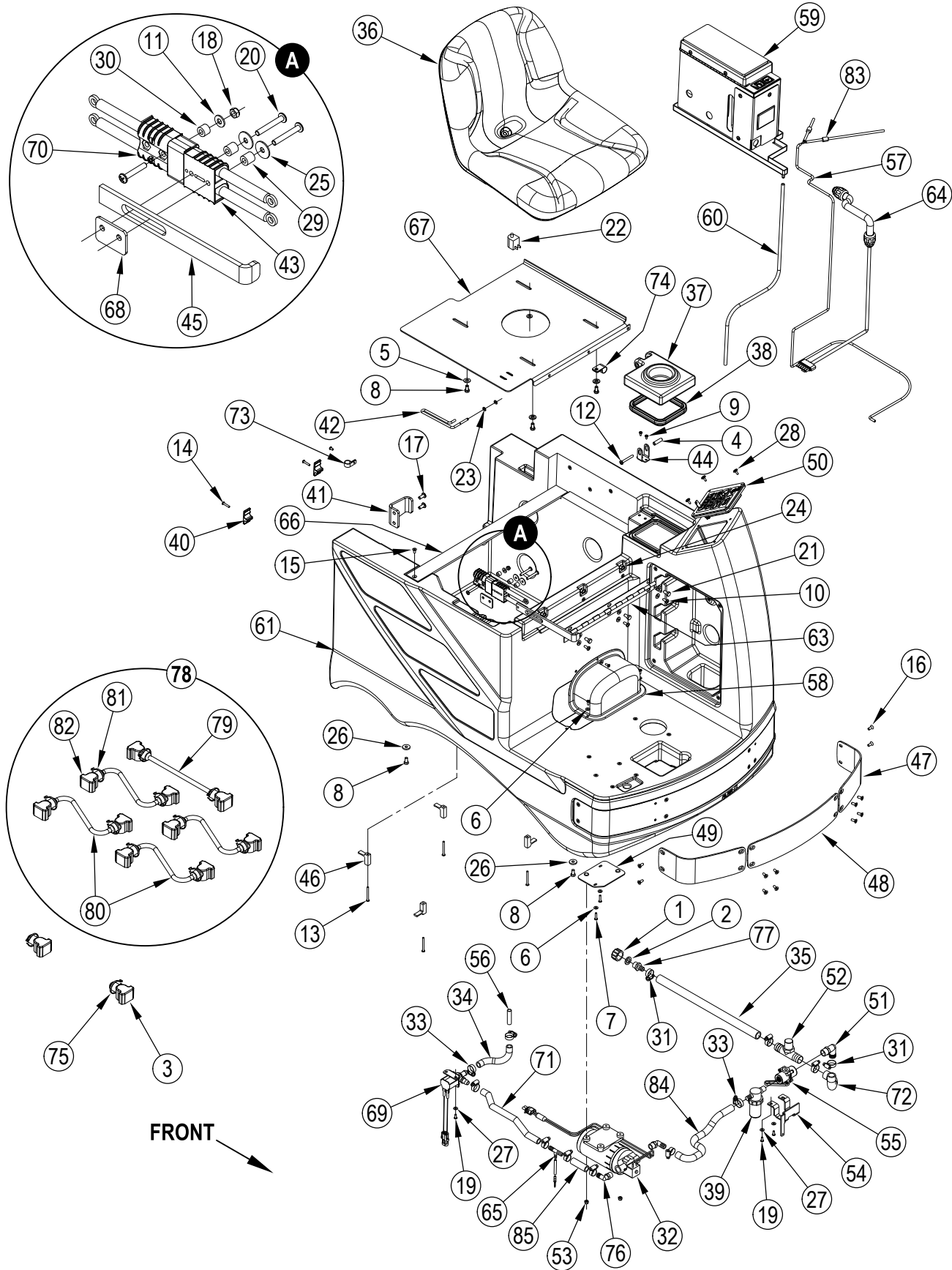

Item	Ref. No.	Qty	Description	Item	Ref. No.	Qty	Description
1	56255076	1	Cap, Pipe GHT Nylon	46	56314608	4	Clamp, Cable
2	56368776	1	Washer, Rubber	47	56314638	2	Bumper, Front
3	56372673	2	Boot, Battery Post	48	56314642	1	Bumper, Front Middle
4	56468553	1	Bushing, .27 x .37 x 1.3	49	56314644	1	Weldment, Adapter Plate
5	56001939	4	Wsh, Flt SAE 5/16	50	56390780	1	Kit Control Board NOTE 3
6	56001954	5	Wsh, Flt SAE #10	[]	56314713	1	Membrane Switch Assy TSBUS2006-932
7	56002733	2	Scr, Pan Phil 10-24 x .88	[]	56396188	1	Switch, Key
8	56002035	8	Scr, Hex 5/16-18 x .62	[]	56396189	1	Key, Spare
9	56002043	3	Scr, Pan Phil 10-24 x .38	51	56314757	1	Barb, 90 Elbow 3/4 x 1/2NPT
10	56002066	3	Scr, Pan Phil 1/4-20 x .62	52	56314758	1	Tee, Barb
11	56002098	7	Wsh, Flt SAE 1/4	53	56002768	2	Nut, Hex Nyl Loc 10-24
12	56002108	1	Scr, Pan Phil 1/4-20 x 2.00	[]	56314787	1	Harness, Cable
13	56002171	4	Scr, Pan Phil 10-24 x 2.00	54	56314881	1	Bracket, Valve
14	56002674	5	Scr, Pan Phil 10-24 x 1.00	55	56314899	1	Valve, Solution
15	56002755	1	Scr, Flt Phil 1/4-20 x .50	56	56314904	1	Tube
16	56002760	12	Scr, Flt Phil 1/4-20 x .62	57	56314863	1	Hose, Chem Resistant
17	56002793	2	Scr, Pan Phil 5/16-18 x .75	58	56314960	1	Cover, Actuator
18	56002840	1	Nut, Hex Nyl Loc-Thin 1/4-20	59	56316537	1	Assy-Detergent Inject. NOTE 1
19	56002900	7	Scr, Pan Phil SS 10-24 x .50	56381100	1	Assy-Detergent Inject. NOTE 2	
20	56002997	3	Scr, Pan Phil 1/4-20 x 1.75				(See Detergent Injection System)
21	56003178	3	Scr, Hex M8-1.25 x 16mm	60	56314965	1	Hose, PVC 1/4 x 3/8
22	7-82-00050	1	Switch (S2)	61	56390853	1	Solution Tank
23	56003268	2	Ring, Ret Ext Type E Reinf. 0.25 Dia	62	56390854	1	Harness, Main (Not Shown)
24	56003389	3	Nut, Hex Nyl Loc M8-1.25	63	56314973	1	Hinge
25	56009002	2	Wsh, Flt .266 x .906 x .060	64	56314980	1	Harness, Detergent System
26	56009122	4	Wsh, Flt .344 x .938 x .125	65	56314983	1	Tee Assembly
27	56009205	4	Wsh, Flt SS .219 x .500 x .047/.062	66	56314985	1	Bracket, Seat
28	56009206	4	Scr, Truss Phil-Blk 10-24 x .50	67	56314986	1	Weld't, Seat Mount
29	56046309	2	Spacer, Phenolic	68	56397189	1	Spacer
30	56050872	1	Spacer, Phenolic	69	56397215	1	Solenoid Valve Assy. 36V
31	56112771	4	Clamp, Hose SAE #10	70	56397508	1	Charge Connector Assy
32	56212014	1	Pump, 36VDC	71	56266108	1	Hose, Spiral .50 ID x 12
[]	56109587	1	Pump Head Assy	72	56410162	1	Hose, Spiral .75 ID x 7.00
[]	56109588	1	Check Valve Assy	73	56442003	1	Clamp, P
33	56219932	8	Clamp, Hose SAE #6	74	56469380	1	Clamp, P
34	56262180	1	Hose, Spiral .50 ID x 7.00	75	56478246	2	Tie, Cable
35	56263218	1	Hose, .75 Clear PVC	76#	56109566	2	Barb 90 Elbow 1/2 X 3/8 NPT
36	8-69-00022	1	Seat	77	56900273	1	Barb
37	56314066	1	Cover, Solution Tank, Assy	78	56314339	1	Kit, Battery Connector (items 79-82)
38	56314069	1	Gasket	79	56441600	1	Cable, Battery
39	56314147	1	Strainer	80	56456460	4	Cable, Battery
40	56314155	5	Clamp, Cable	81	56478246	10	Tie, Cable
41	56316526	1	Tank Mount Bracket	82	56372673	10	Boot, Battery Post
42	56314223	1	Prop Rod	[]	56314119	1	Spacer, Battery
43	56314253	1	Charge Connector Assy	83	56316209	1	Check Valve Assy
44	56314264	1	Hinge Bracket	84	56264318	1	Hose, Spiral .50
45	56314292	1	Bar, Disconnect	85	56111385	1	Hose, Spiral .50

[] = Not Shown

= Revised or new since last update

NOTE 1: Only used on AXP models.**NOTE 2:** Only used on EcoFlex models. AXP models are no longer in production and have been replaced by EcoFlex models.**NOTE 3:** 56314665 is OBSOLETE and replaced by 56390780. 56390780 is used on all models.

SQUEEGEE ASSY

09-9

34

Adgressor™

11-10

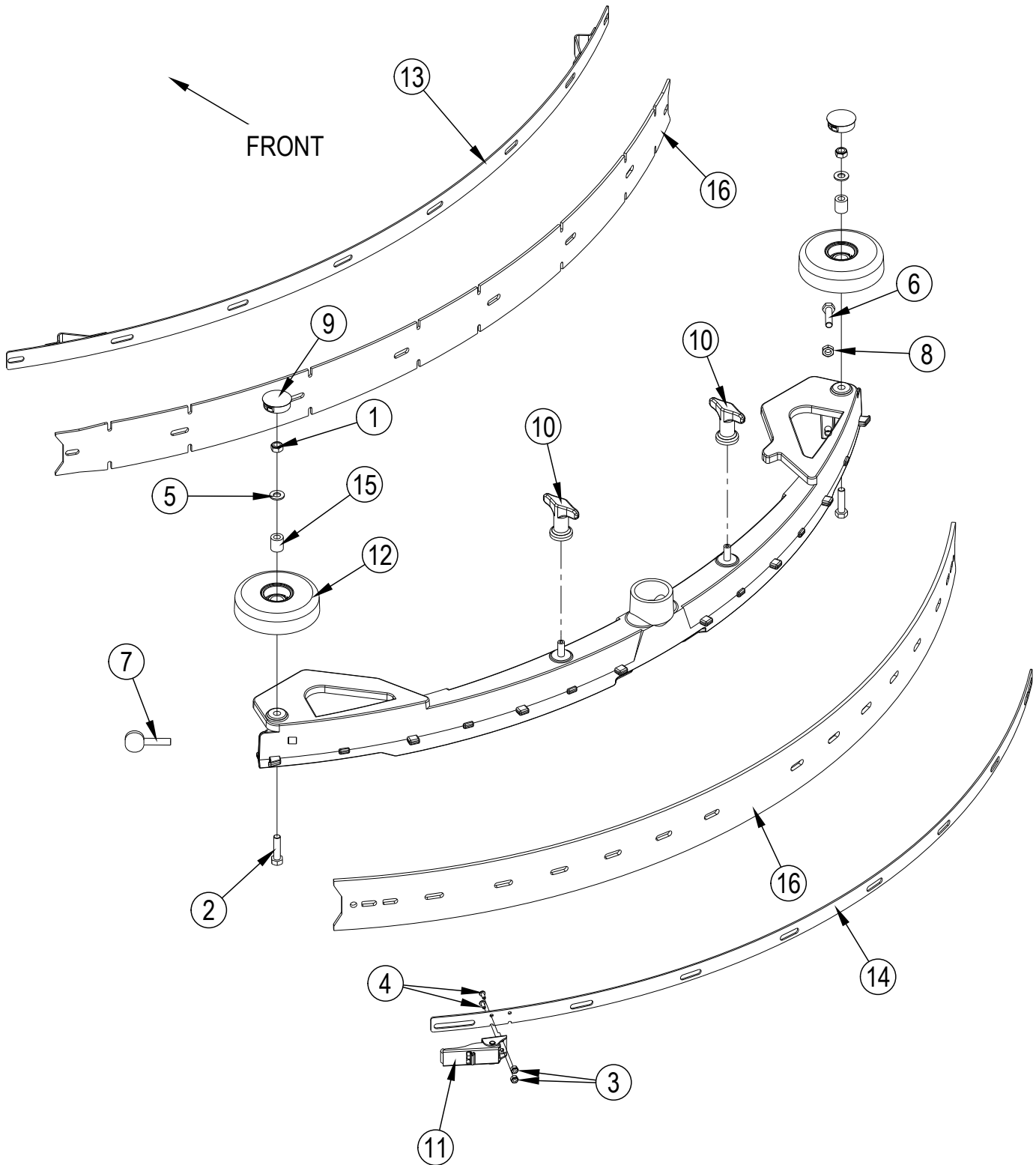

Item	Ref. No.	Qty	Description
	56390865	1	Squeegee Assy (28" Models) NOTE 2
	56390866	1	Squeegee Assy (32", 35" Models) NOTE 2
	56390830	1	Squeegee Assy (38" Models) NOTE 2
1	56002851	2	Nut, Hex Nyl Loc-Thin Ss 5/16-18
2	56002884	2	Scr- Hex Ss 5/16-18 X 1.25
3	56002907	2	Nut, Hex Nyl Loc Ss 6-32
4	56002909	2	Scr, Pan Phil Ss 6-32 X .38
5	56002938	2	Wsh, Flt Sae Ss 5/16
6	56003302	1	Scr, Hex Thd To Hd Ss 5/16-18 X 1.25
7	56003792	1	Scr, Thumb Ss 5/16-18 X 1.25
8	56009141	1	Nut, Hex Jam Ss 5/16-18
9	56111444	2	Button Plug-1.25
10	56370711	2	Nut, Thumb
11	56471194	1	Latch Assembly
12	56601450	2	Wheel, 4.00 Od
13	56601489	1	Front Strap Weldment (28" Models)
	56601495	1	Front Strap Weldment (32", 35" Models)
	56390824	1	Front Strap Weldment (38" Models)
14#	56382676	1	Strap, Rear (28" Models)
	56601496	1	Strap, Rear (32", 35" Models)
	56390826	1	Strap, Rear (38" Models)
15	56601499	2	Bushing, Nylon
16#	56381985	1	Blade Kit, Squeegee Red Gum (28" Models after October 2011) NOTE 1 / NOTE 3
#	56601746	1	Blade Kit, Squeegee Red Gum (28" Models before November 2011) NOTE 1
#	56381986	1	Blade Kit, Squeegee Red Gum (32", 35" Models) NOTE 1
#	56381987	1	Blade Kit, Squeegee Red Gum (38" Models) NOTE 1
28" Model Squeegee Blade Kits			
**#	56382518	1	Blade Kit, Squeegee Gum After October 2011 / NOTE 1 / NOTE 3
**#	56601744	1	Blade Kit, Squeegee Gum Before November 2011 / NOTE 1
#	56381985	1	Blade Kit, Squeegee Red Gum (Standard after October 2011) NOTE 1 / NOTE 3
#	56601746	1	Blade Kit, Squeegee Red Gum (Standard before November 2011) NOTE 1
**#	56382527	1	Blade Kit, Squeegee PU After October 2011 / NOTE 1 / NOTE 3
**#	56601745	1	Blade Kit, Squeegee PU Before November 2011 / NOTE 1
32", 35" Model Squeegee Blade Kits			
**#	56382519	1	Blade Kit, Squeegee Gum NOTE 1
#	56381986	1	Blade Kit, Squeegee Red Gum (Standard) NOTE 1
**#	56382528	1	Blade Kit, Squeegee PU NOTE 1
38" Model Squeegee Blade Kits			
**#	56382520	1	Blade Kit, Squeegee Gum NOTE 1
#	56381987	1	Blade Kit, Squeegee Red Gum (Standard) NOTE 1
**#	56382529	1	Blade Kit, Squeegee PU NOTE 1

** = Optional, Not Included

= Revised or new since last update

NOTE 1: Squeegee Blade Kits include both front & rear squeegee blades.

NOTE 2: These squeegee assemblies include red gum rubber blades. The squeegee tool casting is not available for sale separately. If you need to replace the casting please order a complete squeegee assembly.

NOTE 3: These squeegee blades are designed to provide increased performance and reduced streaking. When installing these blades on a machine built before November 2011 you must also order a new rear strap part number 56382676.

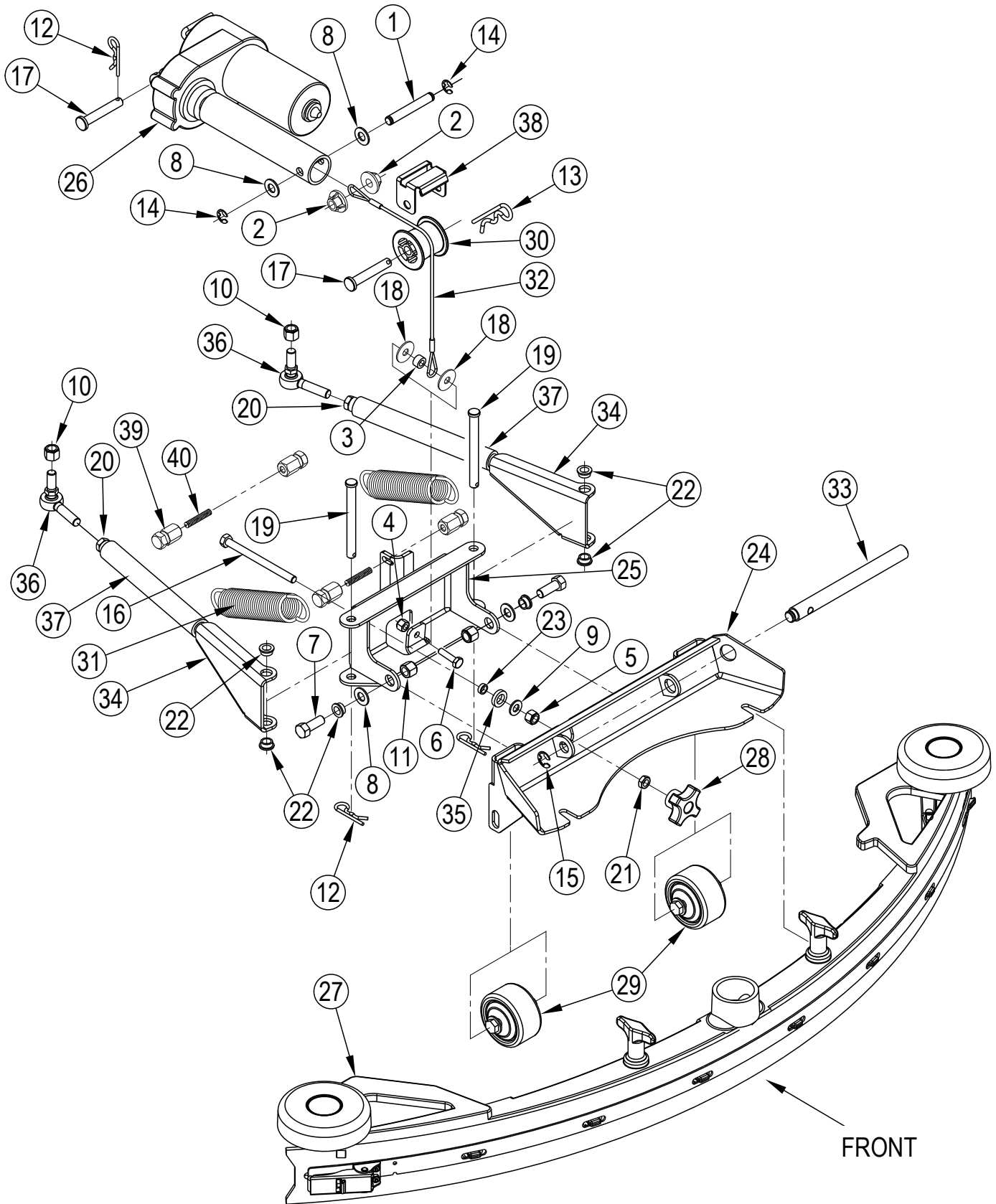

Item	Ref. No.	Qty	Description
1	56412088	1	Pin
2	56412248	2	Spacer, Squeegee Cable
3	56453691	1	Spacer
4	56002491	1	Nut, Hex Nyl Loc Ss 1/4-20
5	56002856	1	Nut, Hex Nyl Loc Ss 5/16-18
6	56002883	1	Scr- Hex Ss 1/4-20 X 1.00
7	56002886	2	Scr- Hex Ss 3/8-16 X 1.00
8	56002910	4	Wsh, Flt Sae Ss 3/8
9	56002938	1	Wsh, Flt Sae Ss 5/16
10	56002951	2	Nut, Hex Nyl Loc 3/8-24
11	56003219	2	Nut, Hex Nyl Loc Ss 3/8-16
12	56003222	3	Pin, Cotter Hair
13	56003223	1	Pin, Cot Hair .148 X Dia .62/1.00
14	56003262	2	Ring, Ret Ext Type E 0.38 Dia
15	56003264	1	Ring, Ret Ext Type E 0.50 Dia
16	56003486	1	Scr, Hex Thd To Hd Ss 5/16-18 X 4.00
17	56003656	2	Pin, Clevis .375 X 2.25
18	56003696	2	Wsh- Flt Ss .33 X 1.00 X.060
19	56003713	2	Pin, Clevis .38 X 3.75
20	56009103	2	Nut, Hex Jam 3/8-24
21	56009141	1	Nut, Hex Jam Ss 5/16-18
22	56324505	6	Bearing, Flange
23	56381818	1	Bushing .32x.44x.15
24	56390849	1	Bracket-Squeegee Mount Weldt
25	56390851	1	Bracket-Squeegee Pivot Weldt
26	56390857	1	Actuator Motor 36v (M2)
27	56390865	1	Squeegee Assembly (28" Models) NOTE 1
	56390866	1	Squeegee Assembly (32", 35" Models) NOTE 1
	56390830	1	Squeegee Assembly (38" Models) NOTE 1
28	56407303	1	Knob
29	56412124	2	Wheel
30	56412208	1	Roller
31	56412216	2	Spring, Extension
32	56390818	1	Cable Assembly
33	56601442	1	Shaft
34	56601460	2	Bar Weldment
35	56601463	1	Washer, Polyurethane
36	56601469	2	Rod End
37	56601512	2	Hose
38	56390799	1	Bracket, Cable
39#	56382624	4	Nut-Spring NOTE 2
40#	56382637	2	Rod-Threaded .25 X 1.25 NOTE 2

= Revised or new since last update

NOTE 1: These squeegee assemblies include Red Gum Rubber blades.

NOTE 2: These parts were implemented in production as of November 2011 to increase squeegee down pressure. Order Squeegee Spring Kit 56382634 to upgrade your machine to include this improvement.

STEERING COLUMN ASSEMBLY

09-9

38

Adressor™

11-7

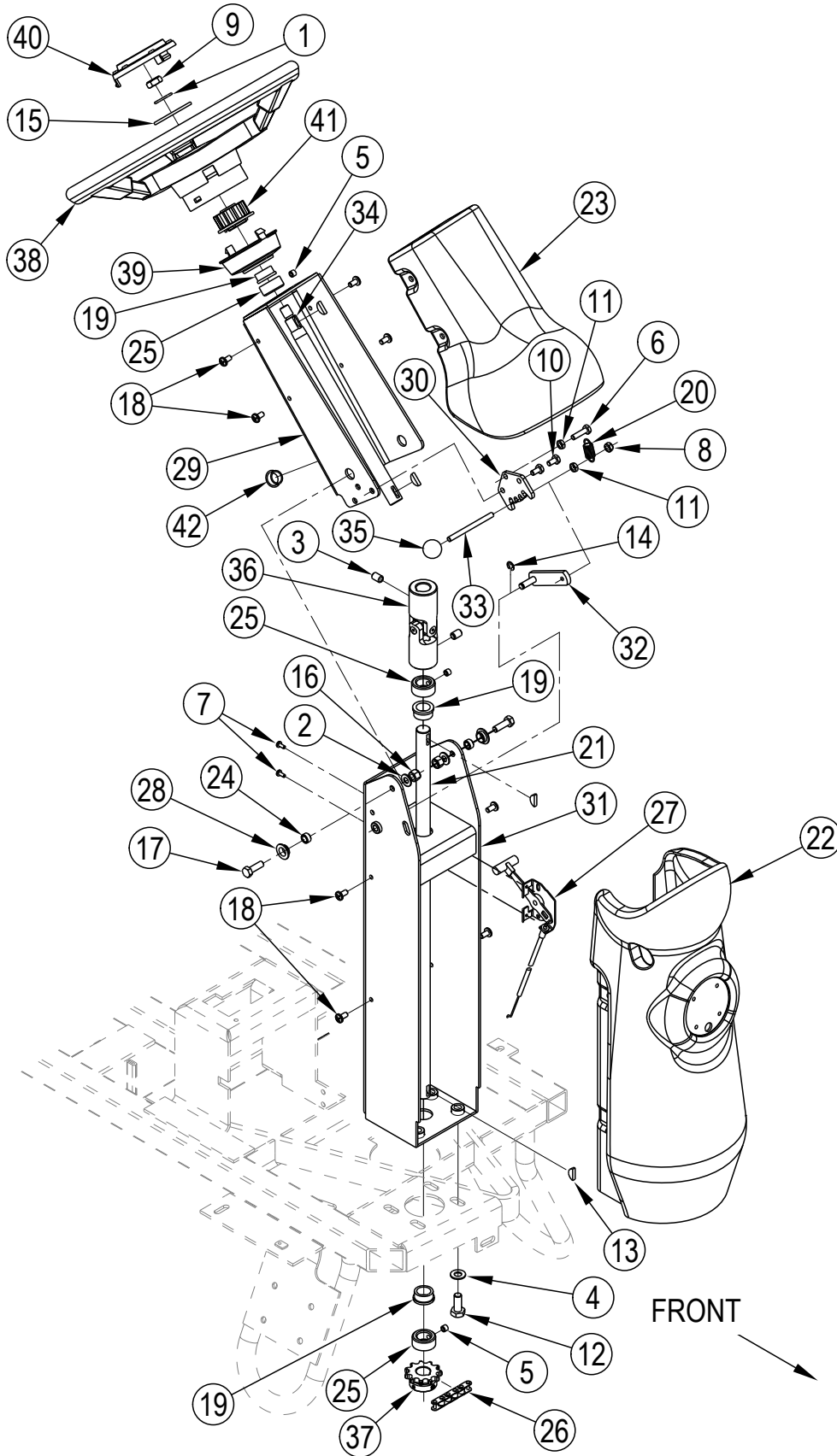

Item	Ref. No.	Qty	Description
1	56001879	3	Wsh-Flt Sae 1/2
2	56001939	2	Wsh, Flt Sae 5/16
3	56001958	2	Scr, Soc Set Loc 3/8-16 X .50
4	56002063	4	Wsh, Flt Sae 3/8
5	56002086	3	Scr, Soc Set Loc 5/16-18 X .25
6	56002093	1	Scr, Hex 1/4-20 X 1.00
7	56002523	2	Scr, Pan Phil Thd Form 8-32 X .38 NOTE 1
8	56002840	1	Nut, Hex Nyl Loc-Thin 1/4-20
9	56002843	1	Nut, Hex Nyl Loc-Thin 1/2-13
10	56003039	2	Scr,Hex Hd Loc 1/4-20x.50
11	56003145	2	Nut, Hex Jam Ss 1/4-20
12	56003186	4	Scr, Hex Thd To Hd M10-1.5 X 25mm
13	56003228	4	Key, Wdf .75 X .19
14	56003261	1	Ring, Ret Ext Type E 0.31 Dia
15	56003342	1	Washer Flt .88x2.25x.13
16	56003389	2	Nut, Hex Nyl Loc M8-1.25
17	56003436	2	Scr, Hex Ss M8-1.25 X 25mm
18	56009062	9	Scr, Pan Phil Thd Form 1/4-20 X .50
19	56250414	3	Bearing, Flange
20	56305072	1	Spring, Extension .075
21	56314195	1	Shaft, Lower Steering
22	56314295	1	Shroud, Lower Column
23	56314296	1	Shroud, Upper Column
24	56320595	2	Bushing .32x.50x.28
25	56367095	3	Collar, Shaft
26	56412198	1	Chain, Roller
27	56412281	1	Solution Control Cable NOTE 1
28	56413211	2	Bearing, Flange .625 X .500 X .250
29	56413657	1	Column, Upper
30	56413658	1	Ratchet, Steering Column
31	56413659	1	Lower Column Weldment
32	56413661	1	Steering Pawl Weldment
33	56413664	1	Rod
34	56420059	1	Shaft, Upper Steering
35	56440817	1	Knob
36	56454081	1	Universal Joint
37	56471148	1	Sprocket
38	56497306	1	Steering Wheel
39	56497308	1	Cup
40	56497543	1	Cap
41	56497560	1	Wheel Adapter
42	56900041	1	Plug, Cap

NOTE 1: Not used on AXP or EcoFlex models.

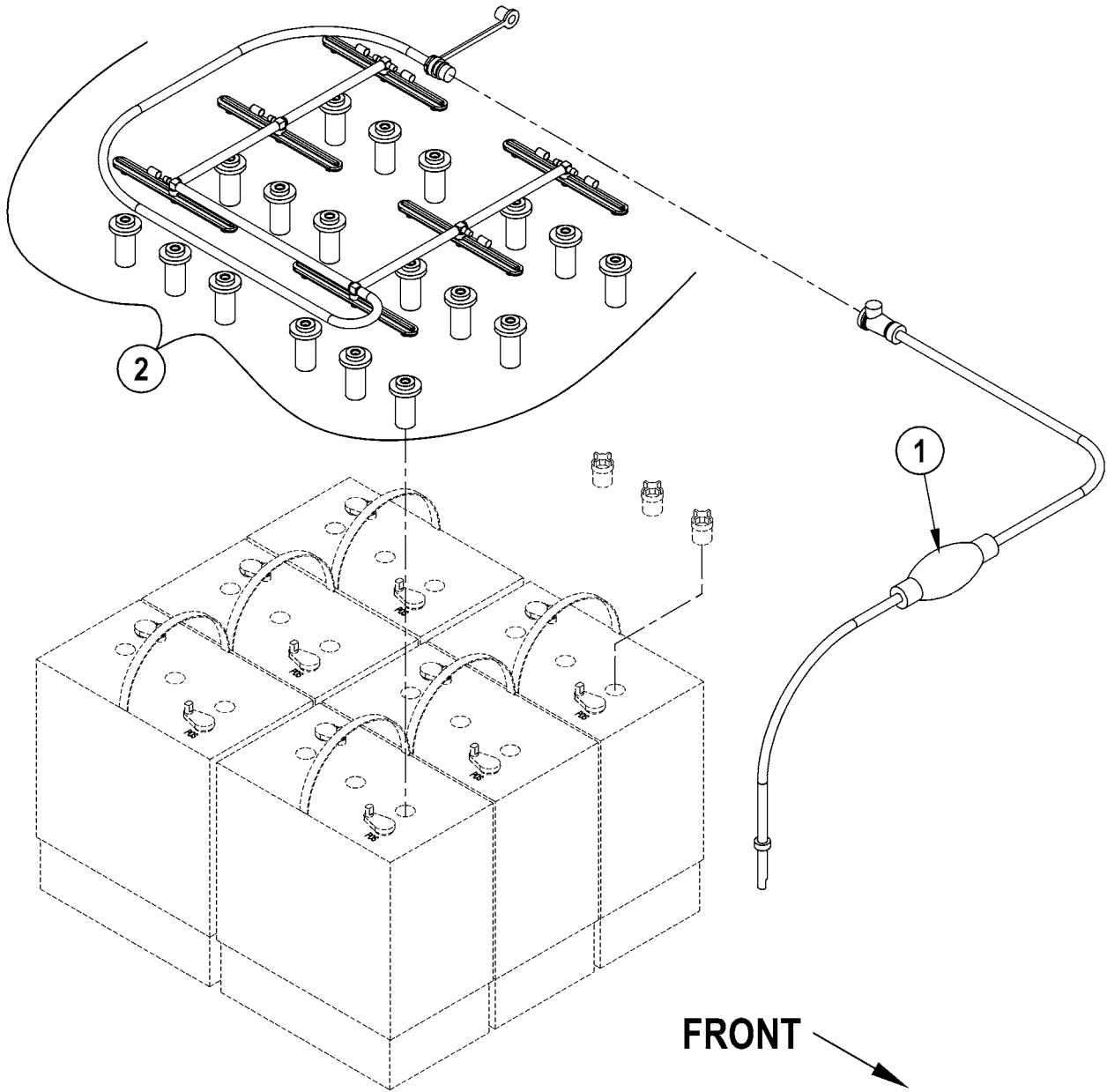

Item	Ref. No.	Qty	Description
	56314974	1	Battery Watering System (items 1-2) (Standard on Detergent Injection Models)
	56314981	1	Battery Watering Kit (includes 56314974)
1	56314978	1	Pump
2	56314979	1	Manifold Assembly

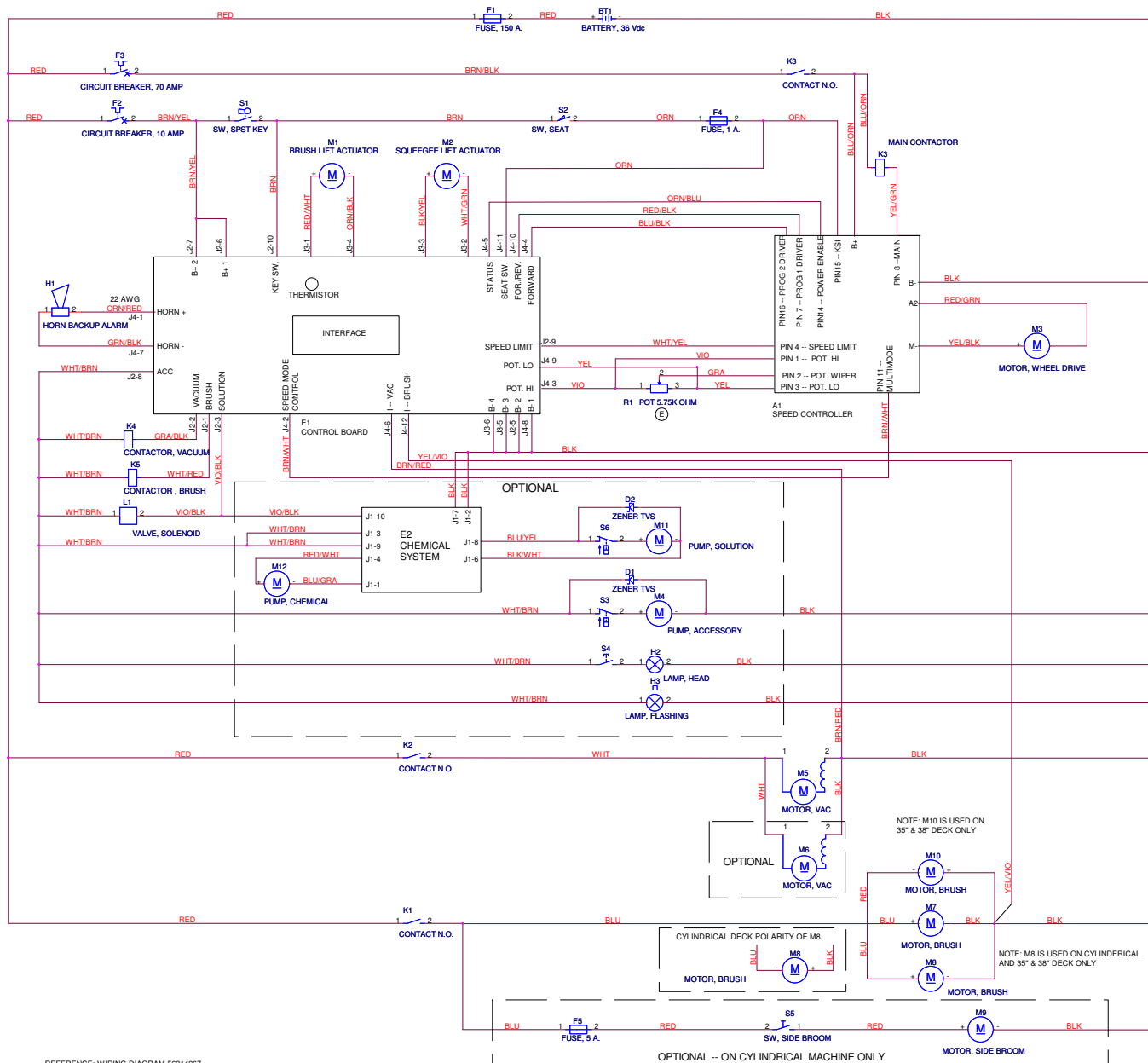

REFERENCE: WIRING DIAGRAM 56314967

PART NO. 56015807 REV. A

Item	Ref. No.	Qty	Description	Item	Ref. No.	Qty	Description
A1	56390856	1	Controller	M7	56314141	1	Motor Gearbox Assy (28" Disk)
BT1	N/A		Battery		56314335	1	Motor Gearbox Assy (32" Disk)
E1	56390780	1	Kit Control Board NOTE 3	[]	56314359	2	Key, 6mm Square
[]	56314713	1	Membrane Switch Assy TSBUS2006-932	[]	56314499	2	Cover, Gearbox
[]	56396188	1	Switch, Key	[]	56314560	2	Gearbox
[]	56396189	1	Key, Spare	[]	56314580	1	Bearing (Fan End)
E2	56316110	1	Control Assembly (Detergent Injection only) NOTE 1	[]	56412323	1	Bearing (Brush End)
	56381078	1	Control Assembly (Detergent Injection only) NOTE 2	[]	56314582	1	Brush Ring
F1	56412089	1	Fuse, 150 Amp	[]	56314583	4	Carbon Brush
F2	56387316	1	Circuit Breaker, 10 Amp (Control Circuit)	[]	56314584	1	Safety Hook
F3	56454429	1	Circuit Breaker, 70 Amp (Wheel Drive)	M7	56407431	1	Motor, 36VDC, .75HP (All Cylindrical)
F4	N/A	1	Fuse, 1 Amp	[]	56407489	1	Armature (for 56407431)
F5		1	Fuse, 5 Amp (Side Broom / optional)	[]	56410183	1	Bearing (for 56407431)
H1	56412177	1	Horn / Backup Alarm	[]	56407492	1	Brush Cap Assy (for 56407431)
H2	56409239	1	Headlight (optional)	[]	56407493	4	Carbon Brush Assy (for 56407431)
H3	56416433	1	Strobe Light (optional)	[]	56407494	4	Brush Cover Cap (for 56407431)
K1	56395453	1	Contact, Brush Motor	M7	56314789	1	Motor Gearbox Assembly (35", 38" Disk)
K2	56395455	1	Contact, Vac Motor	[]	56314785	1	Gearbox, Replacement
K3	56395453	1	Contact, Wheel Drive	[]	56314784	1	Motor, Replacement
L1	56397215	1	Solenoid Valve	[]	56314786	1	Kit, Carbon Brush
M1	56393303	1	Lift Actuator, Brush	M8	56407431	1	Motor, 36VDC, .75HP (All Cylindrical)
[]	56388520	1	Plastic Nut	[]	56407489	1	Armature (for 56407431)
M2	56397230	1	Lift Actuator, Squeegee	[]	56410183	1	Bearing (for 56407431)
M3	56390817	1	Motor / Drive Wheel Assy	[]	56407492	1	Brush Cap Assy (for 56407431)
M4	56212014	1	Motor, Pump (optional)	[]	56407493	4	Carbon Brush Assy (for 56407431)
[]	56109587	1	Pump Head Assy	[]	56407494	4	Brush Cover Cap (for 56407431)
[]	56109588	1	Check Valve Assy	M8	56314789	1	Motor Gearbox Assembly (35", 38" Disk)
M5	56397228	1	Motor, Vac 36VDC	[]	56314785	1	Gearbox, Replacement
[]	56212223	1	Carbon Brush Set	[]	56314784	1	Motor, Replacement
M6	56397228	1	Motor, Vac 36VDC (optional)	[]	56314786	1	Kit, Carbon Brush
[]	56212223	1	Carbon Brush Set	M11	56212014	1	Pump, Solution (Detergent Injection only)
				M12	56314984	1	Pump, Detergent (Detergent Injection only)
				R1	NA	1	Potentiometer, 5.75K NOTE 4
				S1	56396188	1	Switch, Key
				[]	56396189	1	Key, Spare
				S2	7-82-00050	1	Switch, Seat
				S3	N/A	1	Switch, Pump (part of M4)
				S4	N/A	1	Switch, Headlight (part of H2)
				S5	56372088	1	Switch, Side Broom (optional)
				S6	N/A	1	Switch, Pump (part of M11)

[] = Not Shown

** = Optional

NOTE 1: Only used on AXP models.**NOTE 2:** Only used on EcoFlex models. AXP models are no longer in production and have been replaced by EcoFlex models.**NOTE 3:** 56314665 is OBSOLETE and replaced by 56390780. 56390780 is used on all models.**NOTE 4:** Potentiometer is part of 56601052.

OPTIONAL KITS & ACCESSORIES

09-9

44

Adgressor™

11-10

Item	Ref. No.	Qty	Description	Item	Ref. No.	Qty	Description
**	56314753	1	Kit, Onboard Charger TSBUS2004-872 / TSBUS2009-1027				35" Disk Deck Blade Kit
**	56314301	1	Kit, Seat Armrests (for 56314035)	56314846	1	1	Kit, Red Gum Rubber 35 Disk (Standard) NOTE 2
**	7-03-04249	1	Kit-Seat Armrests (for 8-69-00022)	**	56390927	1	Blade Kit-Disk PU NOTE 2
**	56314302	1	Kit, Warning Beacon	**	56315720	1	Kit, Red Gum Rubber NOTE 3
**	56314306	1	Kit, Right Side Broom				38" Disk Deck Blade Kits
**	56314308	1	Kit, Scrub-N-Vac Tool W/Pump	56314848	1	1	Kit, Red Gum Rubber 38 Disk (Standard) NOTE 2
**	56412223	1	Kit, Vacuum Wand Caddy	**	56390796	1	Blade Kit-Disk Gum NOTE 2
**	56314312	1	Kit, Seatbelt	**	56315720	1	Kit, Red Gum Rubber NOTE 3
**	56314313	1	Kit, Headlight	**	56390788	1	Blade Kit-Disk Gum NOTE 3
**	56390761	1	Kit, Deck 2820D				Accessories
**	56390762	1	Kit, Deck 2820C	**	56409441	A/R	Programmer, 1311 User
**	56390764	1	Kit, Deck 3220D	**	56409823	A/R	Programmer Cable
**	56390769	1	Kit, Deck 3220C	**	56044425	1	Literature Pack (all models prior to introduction of EcoFlex)
**	56390772	1	Kit, Deck 3520D	**	56044594	1	Literature Pack (all models after introduction of EcoFlex)
**	56390775	1	Kit, Deck 3520C				** = Optional, Not Included
**	56390776	1	Kit, Deck 3820D				# = Revised or new since last update
**	56390777	1	Kit, Deck 3820C				
**	56397453	1	Kit, Battery Fill Indicator				
**	56314981	1	Kit, Battery Watering				
**	56314338	1	Kit, Dual Vac Motor				
**	56314698	1	Kit, Onboard Charger, GEL				
			TSBUS2008-984 / TSBUS2009-1027				
**	56316251	1	Kit, Onboard Charger, AGM TSBUS2008-984				
			TSBUS2008-984 / TSBUS2009-1027				

Replacement parts for the kits listed above can be found on each kit's associated instruction sheet.

			28" Model Squeegee Blade Kits
**#	56382518	1	Blade Kit, Squeegee Gum After October 2011 / NOTE 1 / NOTE 5
**#	56601744	1	Blade Kit, Squeegee Gum Before November 2011 / NOTE 1
#	56381985	1	Blade Kit, Squeegee Red Gum (Standard after October 2011) NOTE 1 / NOTE 5
#	56601746	1	Blade Kit, Squeegee Red Gum (Standard before November 2011) NOTE 1
**#	56382527	1	Blade Kit, Squeegee PU After October 2011 / NOTE 1 / NOTE 5
**#	56601745	1	Blade Kit, Squeegee PU Before November 2011 / NOTE 1
			32", 35" Model Squeegee Blade Kits
**#	56382519	1	Blade Kit, Squeegee Gum NOTE 1
#	56381986	1	Blade Kit, Squeegee Red Gum (Standard) NOTE 1
**#	56382528	1	Blade Kit, Squeegee PU NOTE 1
			38" Model Squeegee Blade Kits
**#	56382520	1	Blade Kit, Squeegee Gum NOTE 1
#	56381987	1	Blade Kit, Squeegee Red Gum (Standard) NOTE 1
**#	56382529	1	Blade Kit, Squeegee PU NOTE 1
			28" Disk Deck Blade Kits
**	56314913	1	Kit, Gum Rubber 28 Disk NOTE 2
**	56314917	1	Kit, Red Gum Rubber 28 Disk (Standard) NOTE 2
**	56390967	1	Blade Kit-Disk PU NOTE 2
**	56315722	1	Kit, Gum Rubber NOTE 3
**	56315721	1	Kit, Red Gum Rubber NOTE 3
			32" Disk Deck Blade Kits
**	56314914	1	Kit, Gum Rubber 32 Disk NOTE 2
**	56314918	1	Kit, Red Gum Rubber 32 Disk (Standard) NOTE 2
**	56315722	1	Kit, Gum Rubber NOTE 3
**	56315721	1	Kit, Red Gum Rubber NOTE 3
			35", 38" Cylindrical Deck Blade Kits
**	56314860	1	Kit, Deck Blade Cyl Red Gum Rubber (Standard) NOTE 4
**	56390791	1	Kit Cyl Blade Gum NOTE 4

NOTE 1: Squeegee Blade Kits include both front & rear squeegee blades.

NOTE 2: These Disk Deck Blade Kits include required mounting fasteners (Rivet, Nylon Tree Push-In 56003263) the 2 blades (front and rear) for the deck and all skirt assembly blades.

NOTE 3: These Disk Deck Blade Kits include just the blades for use in the two Skirt Assemblies.

NOTE 4: For use on 35" and 38" decks. These kits include all blades required for both the deck and skirts.

NOTE 5: These squeegee blades are designed to provide increased performance and reduced streaking. When installing these blades on a machine built before November 2011 you must also order a new rear strap part number 56382676.

Item	Ref. No.	Qty	Description	Item	Ref. No.	Qty	Description
			28" Disk Scrub Brushes				28" Cylindrical Scrub Brushes
**	56505800	2	Short Trim Pad Holder	**	56412191	2	Soft Nylon
**	56505195	2	Pad Retainer for 56505750	**	56412192	2	Hard Nylon
**	56505805	2	ProLite	**	56412046	2	Prolene
**	56505804	2	Prolene	**	56412193	2	MidLite Grit 180
**	56505806	2	Union Mix	**	56412194	2	Dyna Grit 80
**	56505803	2	AgLite Grit 500	**	56412195	2	Magna Grit 46
**	56505807	2	MidGrit 240				32" Cylindrical Scrub Brushes
**	56505808	2	MidLite Grit 180	**	56407473	2	Soft Nylon
**	56505802	2	Dyna Grit 80	**	56407474	2	Hard Nylon
**	56505801	2	Magna Grit 46	**	56407475	2	Prolene
			32" Disk Scrub Brushes	**	56407476	2	MidLite Grit 180
**	56505830	2	Short Trim Pad Holder	**	56407477	2	Dyna Grit 80
**	56505195	2	Pad Retainer for 56505750	**	56407478	2	Magna Grit 46
**	56505835	2	ProLite				35" Cylindrical Scrub Brushes
**	56505834	2	Prolene	**	56314778	2	Soft Nylon
**	56505836	2	Union Mix	**	56314779	2	Hard Nylon
**	56505833	2	AgLite Grit 500	**	56314780	2	Prolene
**	56505837	2	MidGrit 240	**	56314781	2	MidLite Grit 180
**	56505838	2	MidLite Grit 180	**	56314782	2	Dyna Grit 80
**	56505832	2	Dyna Grit 80	**	56314783	2	Magna Grit 46
**	56505831	2	Magna Grit 46				38" Cylindrical Scrub Brushes
			35" Disk Scrub Brushes	**	56410294	2	Soft Nylon
**	56505750	2	Short Trim Pad Holder	**	56410295	2	Hard Nylon
**	56505195	2	Pad Retainer for 56505750	**	56410293	2	Prolene
**	56505755	2	ProLite	**	56410296	2	MidLite Grit 180
**	56505754	2	Prolene	**	56410297	2	Dyna Grit 80
**	56505756	2	Union Mix	**	56410298	2	Magna Grit 46
**	56505753	2	AgLite Grit 500				
**	56505757	2	MidGrit 240				
**	56505758	2	MidLite Grit 180				
**	56505752	2	Dyna Grit 80				
**	56505751	2	Magna Grit 46				
			38" Disk Scrub Brushes				
**	56505760	2	Short Trim Pad Holder				
**	56505195	2	Pad Retainer for 56505750				
**	56505765	2	ProLite				
**	56505764	2	Prolene				
**	56505766	2	Union Mix				
**	56505763	2	AgLite Grit 500				
**	56505767	2	MidGrit 240				
**	56505768	2	MidLite Grit 180				
**	56505762	2	Dyna Grit 80				
**	56505761	2	Magna Grit 46				

We provide brushes and pad holders that will give you the best possible performance between machine and floor. Following are descriptions of the materials and their applications.

- ProLite:** Bristles are made from light-duty polypropylene for general scrubbing when you do not want to scratch or remove finish from the floor. Recommended for use in place of red pads.
- Prolene:** Polypropylene material for medium-duty scrubbing on concrete, terrazzo and vinyl floor tile. Recommended for use in place of green or blue pads.
- Union Mix:** Medium grade natural fibers for polishing finished floors with standard-speed equipment. Recommended for use in place of white pads.
- AgLite Grit 500:** For light scrubbing when used wet; buffing or polishing when used dry on urethane coated, sealed concrete or other resilient hard surface floors. Recommended for use in place of red or white pads.
- MidGrit 240:** For general purpose scrubbing when you need a lighter action for sealed or unsealed concrete, stone, terrazzo, quarry tile and other resilient hard floor surfaces. Recommended for use in place of green or blue pads.
- MidLite Grit 180:** For general purpose scrubbing of sealed or unsealed concrete, stone, terrazzo, quarry tile and other resilient hard floor surfaces. Recommended for use in place of green or blue pads.
- Dyna Grit 80:** For aggressive, heavy-duty scrubbing or stripping of floors. Recommended for use in place of brown pads.
- Magna Grit 46:** For extreme heavy-duty scrubbing or stripping of floors. This brush has extra large diameter silicon carbide grit impregnated synthetic bristles. Recommended for use in place of black pads.
- Short Trim Pad Holder:** Made with a structural foam block and center ring for correct pad centering. It has a "shower feed" design for getting solution to the floor.

28" BRUSHES

56505800 - Short Trim Pad Holder
 56505195 - Pad Retainer for 56505800
 56505805 - Prolite
 56505804 - Prolene
 56505806 - Union Mix
 56505803 - AgLite Grit 500
 56505807 - MidGrit 240
 56505808 - MidLite Grit 180
 56505802 - Dyna Grit 80
 56505801 - Magna Grit 46

32" BRUSHES

56505830 - Short Trim Pad Holder
 56505195 - Pad Retainer for 56505830
 56505835 - Prolite
 56505834 - Prolene
 56505836 - Union Mix
 56505833 - AgLite Grit 500
 56505837 - MidGrit 240
 56505838 - MidLite Grit 180
 56505832 - Dyna Grit 80
 56505831 - Magna Grit 46

35" BRUSHES

56505750 - Short Trim Pad Holder
 56505195 - Pad Retainer for 56505750
 56505755 - Prolite
 56505754 - Prolene
 56505756 - Union Mix
 56505753 - AgLite Grit 500
 56505757 - MidGrit 240
 56505758 - MidLite Grit 180
 56505752 - Dyna Grit 80
 56505751 - Magna Grit 46

38" BRUSHES

56505760 - Short Trim Pad Holder
 56505195 - Pad Retainer for 56505760
 56505765 - Prolite
 56505764 - Prolene
 56505766 - Union Mix
 56505763 - AgLite Grit 500
 56505767 - MidGrit 240
 56505768 - MidLite Grit 180
 56505762 - Dyna Grit 80
 56505761 - Magna Grit 46

DISC BRUSH APPLICATION GUIDE (SUGGESTION ONLY)

	46	80	180	240	500	Prolene	Prolite	Union
Application	Grit	Grit	Grit	Grit	Grit			Mix
Stripping:								
Concrete	X	X						
Terrazzo	X	X						
Ceramic/Quarry tile		X						
Vinyl tile		X						
General Scrubbing:								
Concrete	X	X	X	X		X		
Terrazzo			X	X	X	X		
Ceramic/Quarry tile			X	X	X	X		
Marble					X		X	
Vinyl tile			X		X	X		
Raised-rubber tile					X		X	
Polishing:								
Raised Disc Tile								X
Marble								X
Vinyl tile								X

We provide brushes and pad holders that will give you the best possible performance between machine and floor. Following are descriptions of the materials and their applications.

- Soft Nylon:** Least aggressive brush available. Used on soft-finish floors where a more aggressive brush would leave scratch marks, or in applications requiring very light cleaning.
- Stiff Nylon:** Cleaning action similar to polypropylene. More durable and wear-resistant than polypropylene.
- Prolene:** Low cost, yet effective in cleaning many common floor surfaces.
- MidLite Grit 180:** Least aggressive grit brush. Used for daily cleaning of hard-finished floors.
- Dyna Grit 80:** Medium aggressive grit brush. Good all-around brush for medium to heavy buildup removal. Can also be used for general stripping operations.
- Magna Grit 46:** Most aggressive grit brush. Used primarily to clean heavy buildup on concrete floors in factories, or for heavy stripping of finish.

28" BRUSHES

56412191 - Soft Nylon
 56412192 - Hard Nylon
 56412046 - Prolene
 56412193 - MidLite Grit 180
 56412194 - Dyna Grit 80
 56412195 - Magna Grit 46

32" BRUSHES

56407473 - Soft Nylon
 56407474 - Hard Nylon
 56407475 - Prolene
 56407476 - MidLite Grit 180
 56407477 - Dyna Grit 80
 56407478 - Magna Grit 46

35" BRUSHES

56314778 - Soft Nylon
 56314779 - Hard Nylon
 56314780 - Prolene
 56314781 - MidLite Grit 180
 56314782 - Dyna Grit 80
 56314783 - Magna Grit 46

38" BRUSHES

56410294 - Soft Nylon
 56410295 - Hard Nylon
 56410293 - Prolene
 56410296 - MidLite Grit 180
 56410297 - Dyna Grit 80
 56410298 - Magna Grit 46

CYLINDRICAL BRUSH APPLICATION GUIDE (SUGGESTION ONLY)

Application	46 Grit	80 Grit	180 Grit	Polypro- pylene	Stiff Nylon	Soft Nylon
Stripping:						
Concrete	X	X				
Terrazzo	X	X				
Ceramic/Quarry tile		X				
Vinyl tile		X				
General Scrubbing:						
Concrete	X	X	X	X	X	
Terrazzo			X	X	X	X
Ceramic/Quarry tile			X	X	X	X
Marble			X		X	X
Vinyl tile			X	X	X	X
Raised-rubber tile			X			X

SQUEEGEE BLADE SELECTOR GUIDE

09-9

48

Adgressor™

11-2

Gum Rubber: Provides superior wiping action on tile, terrazzo, and polished floors.

Red Gum Rubber: Provides longest life on finished or unfinished concrete floors.

Polyurethane: Oil resistance provides superior life in applications with oily floors.

SQUEEGEE BLADE APPLICATION GUIDE(SUGGESTION ONLY)

Performance Traits	Gum Rubber (Natural Rubber)	Red Gum Rubber (Natural Rubber)	Polyurethane/ Pentathane
Resilience	X		X
Tear Strength	X		X
Abrasion Resistance	X	X	X
Wear Resistance		X	X
Low Temp Flexibility	X	X	
High Temp Flexibility	X		X
Ozone Resistance			
Chemical Resistance			X
Applications			
Oil Resistant Applications			X
General Purpose	X	X	X
Hot Water Applications		X	X
Chemical Applications			X
Color	Tan	Red	Translucent



Nilfisk-Advance Equipamentos de Limpeza Ltda.
Av. Dep. Emílio Carlos, 2.499 - Bairro do Limão - 02721-200
São Paulo - SP - Brasil
www.nilfisk-advance.ind.br
www.plataforma.ind.br
Tel.: (11) 3959-0300
Fax: (11) 3959-0306
©2011 Nilfisk-Advance, Inc.



14600 21st Avenue North
Plymouth, MN 55447-3408
www.advance-us.com
Phone: 800-989-2235
Fax: 800-989-6566
©2011 Nilfisk-Advance, Inc.

A Nilfisk-Advance Brand