



 EQUIPMENT

 PARTS

 RENTALS

 SERVICE

 SUPPLIES

USE AND MAINTENANCE MANUAL

CONTACT US

 800.6.Bortek

 717.737.7591

 Orders@BortekIndustries.com

 BortekIndustries.com/CUSTOMERLINK



HAMMERHEAD®

500RS
GEN II

500SS
GEN II

500RSX
GEN II



SUMMARY

SUMMARY	3
INTRODUCTION:	4
HOW TO ORDER:	4
UPDATES FROM THE PREVIOUS VERSION:	4
RAPID CONSULTATION (ELECTRONIC FORMAT)	4
BRUSHES BASE ASSEMBLY 500RS - 500RSX	5
BRUSHES BASE PREASSEMBLY 500RS - 500RSX	7
BRUSHES BASE ASSEMBLY 500 SS	9
BRUSHES BASE PREASSEMBLY 500 SS	11
SQUEEGEE ASSEMBLY	13
SQUEEGEE CONTROL ASSEMBLY	15
CONTROL BASE AND FRAME ASSEMBLY 500RS	17
CONTROL BASE AND FRAME ASSEMBLY 500RSX - 500SS	19
TANK ASSEMBLY	21
SOLUTION TANK PREASSEMBLY	25
SOLUTION TANK PREASSEMBLY	27
SUCTION MOTOR ASSEMBLY	29
WATER UNIT	31
ELECTRIC COMPONENTS 500RS	33
ELECTRIC COMPONENTS 500RSX - 500SS	35
GROUP CHARGER	37
GROUP LABELS HAMMERHEAD 500RS	39
GROUP LABELS HAMMERHEAD 500RSX	40
GROUP LABELS HAMMERHEAD 500SS	41

The contained descriptions in the present publication are not binding. The Manufacturer therefore reserves itself the right to bring in whatever moment possible organs changes, details or supplies of accessories, that it holds convenient for an improvement, or for any demand of constructive or commercial character.

The partial reproduction of the texts and diagrammes contained in the present catalog, is forbidden by law.

The Manufacturer reserves itself the right to bring changes of technical character and/or of endowment. The images are meant of pure reference and not binding in terms of design and endowment.

INTRODUCTION:

This catalogue is intended to serve as a guide for the ordering of spare parts and is designed to facilitate rapid identification of the machine in all its versions and to rapid location of its component parts.

HOW TO ORDER:

For the purpose of simplifying stock searching and the delivery of spare parts, we would ask our customers to observe the following standard procedures, at all times specifying:

- The model and part number of the machine;
- The position number and the number of the table of chart in which the parts appear;
- Ordering code and part name;
- Quantity of parts required;
- Precise address and company status of the purchaser placing the order, complete with address for delivery of the goods;
- Shipping means required.

UPDATES FROM THE PREVIOUS VERSION:

→ = This document is valid since the serial number.

← = This document is valid till the serial number.

	PAG.	N. DOC.	VER.	MATRICOLA
→	20	10016322	AC	
→	26	10012800	AC	
→	70	10028995	AC	214008863
→	74	10028992	AC	214008863
→	78	10028999	AC	214008863

	PAG.	N. DOC.	VER.	MATRICOLA
→	82	10029001	AC	214008863

RAPID CONSULTATION (ELECTRONIC FORMAT)

For a rapid consultation of the electronic document, use "Bookmarks" and "Page Links".

send you to the desired destination.



Bookmarks:

Activate the "Bookmarks" panel of the interface browser, clicking on the icon associated with it (1), the icon can vary depending on the version of the Acrobat display.



Display the bookmarks in the desired language, selecting from IT-EN-FR-DE-ES. To display the desired page, just click on the title in the browser (2) and it will send you to the desired destination.

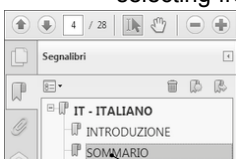

Page Links:

In the Document Summary, to display the desired page just click on the corresponding page number, and it will

10050032-AA

01

CR-01 GROUP BASE BRUSH 500RS - 500RSX

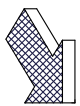
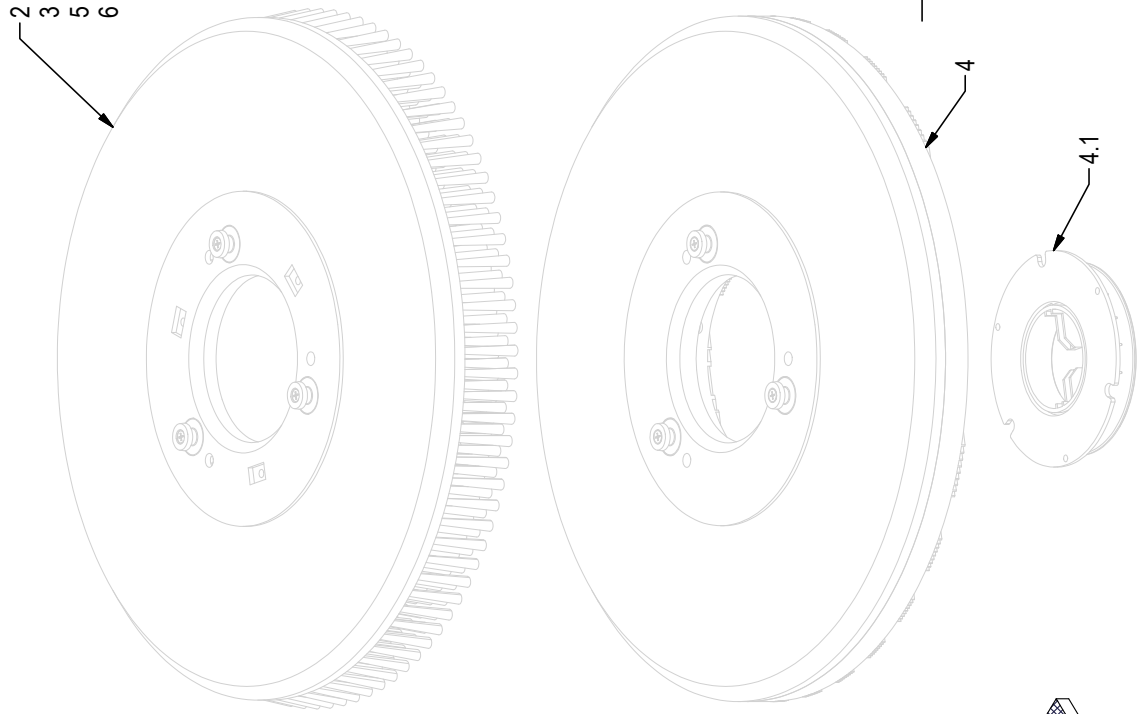
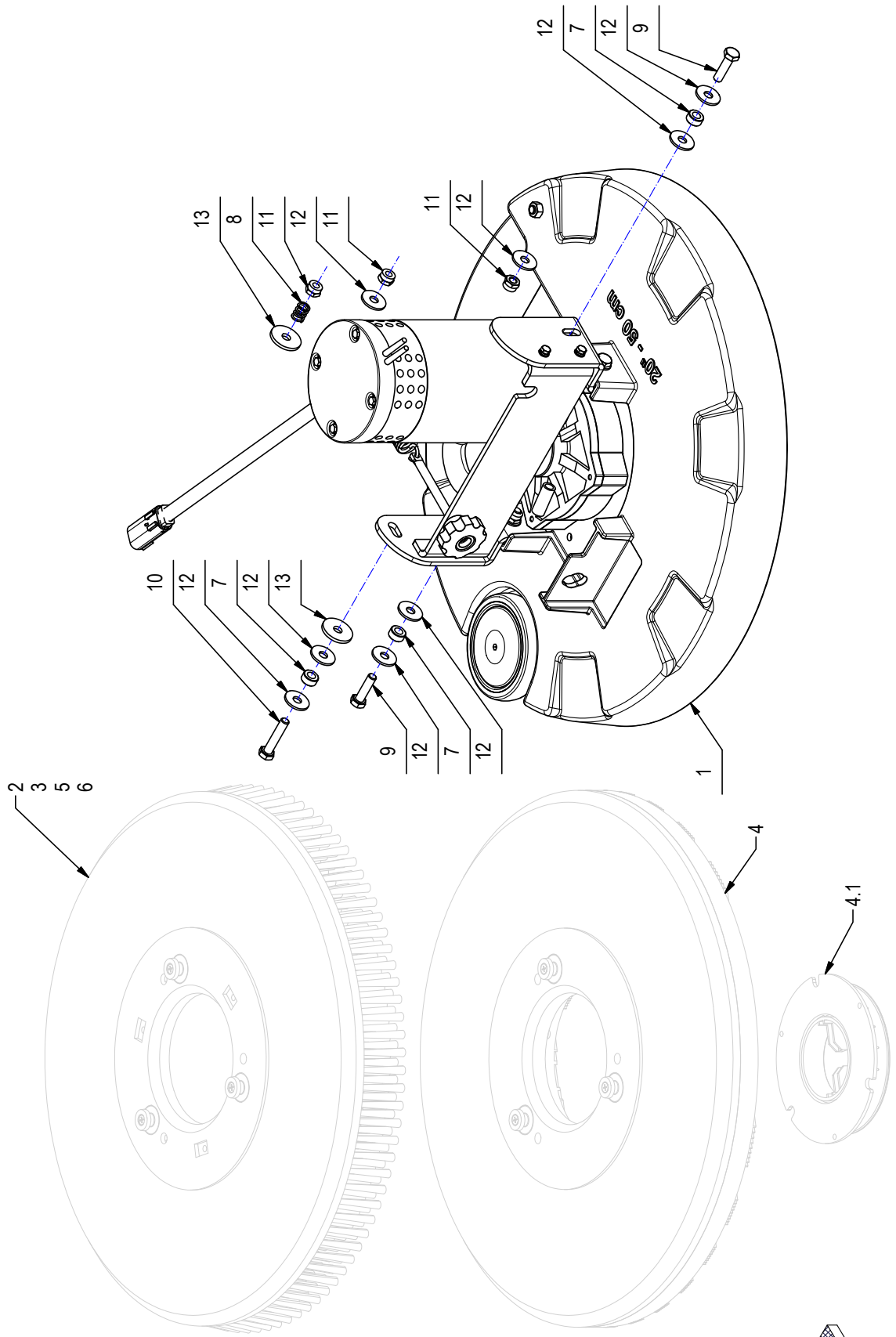

10050032-AA

01

CR-01 GROUP BASE BRUSH 500RS - 500RSX

POS	CODE	Q.TY	DENOMINATION
1	224207	1	BRUSH BASE ASSEMBLY
2	404653	1	BRUSH D=508mm PPL0.9
3	404654	1	BRUSH D=508mm PPL0.3
4	405527	1	PAD HOLDER
4.1	410575	1	CENTER LOCK
5	405631	1	BRUSH D=508mm PPL0.6
6	405632	1	BRUSH ABRASIVE
7	408041	3	BUSHING
8	408094	1	SPRING
9	408676	2	SCREW
10	408679	1	SCREW
11	409085	3	LOCK NUT
12	409179	8	WASHER
13	409182	2	WASHER

10050034-AA

01A

CR-01A PREASSEMBLY BASE BRUSH 500RS - 500RSX

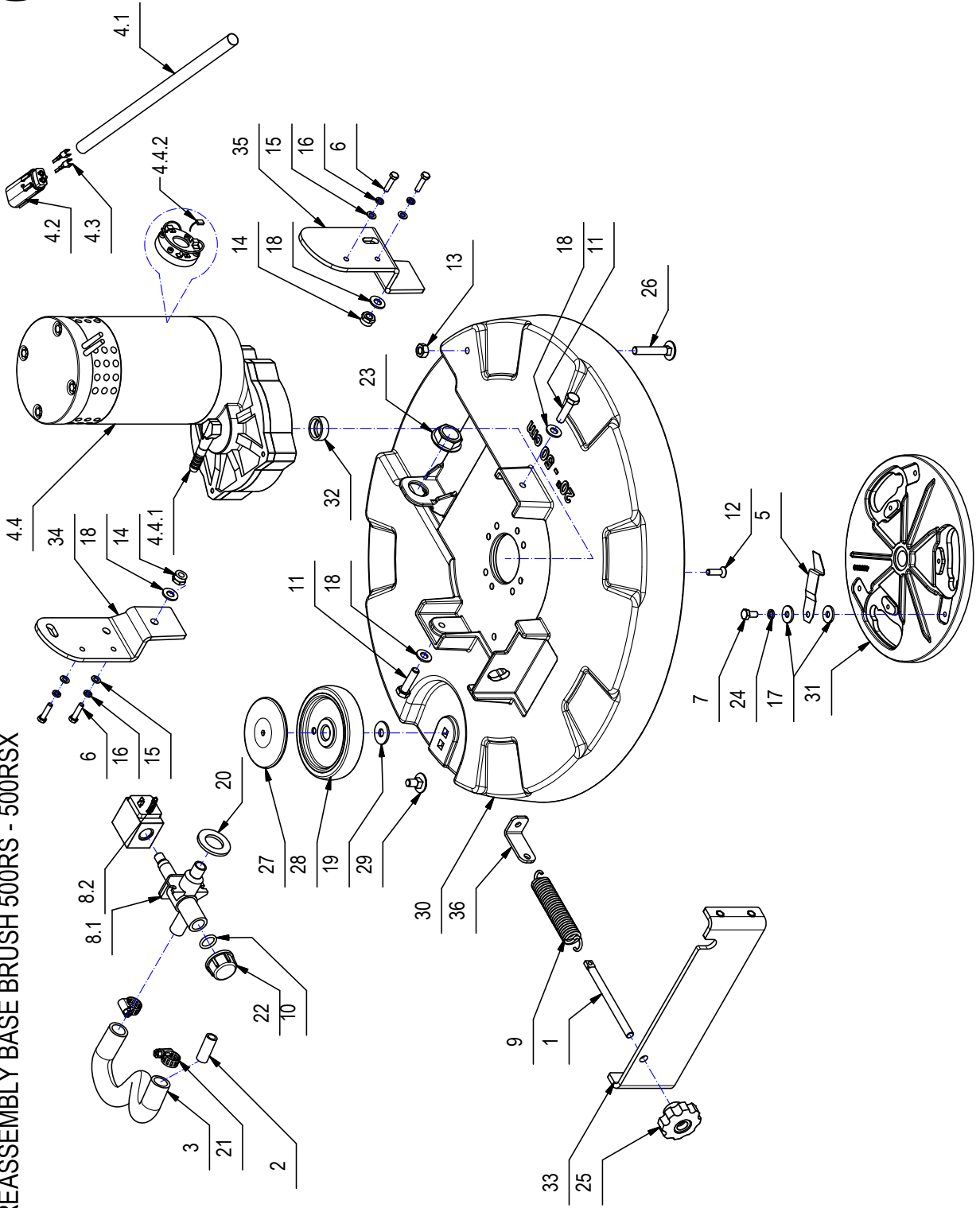

10050034-AA

01A

CR-01A PREASSEMBLY BASE BRUSH 500RS - 500RSX

POS	CODE	Q.TY	DENOMINATION	POS	CODE	Q.TY	DENOMINATION
1	206061	1	ADJUSTER	28	436120	1	BUMPER
2	221379	1	PIPE	29	436341	1	SCREW
3	223181	1	PIPE	30	437855	1	BRUSH BASE
4	223301	1	GEARED MOTOR ASSEMBLY	31	437859	1	FLANGE
4.1	414378	1	SHEATH	32	438110	1	SPACER
4.2	436411	1	CONNECTOR FEMALE	33	439821	1	SUPPORT
4.3	436413	2	CONTACT	34	439822	1	SUPPORT
4.4	438300	1	GEARED MOTOR ASSEMBLY	35	439823	1	SUPPORT
4.4.1	423060	1		36	439824	1	SUPPORT
4.4.2	422462	4	CARBON BRUSH MOTOR				
5	407598	1	SPRING				
6	407647	4	SCREW				
7	407660	1	SCREW				
8	407887	1	SOLENOID VALVE				
8.1	407859	1	SOLENOID VALVE BODY				
8.2	407866	1	COIL				
9	408110	1	SPRING				
10	408595	1	GASKET				
11	408676	2	SCREW				
12	408967	4	SCREW				
13	409049	1	NUT				
14	409085	2	LOCK NUT				
15	409150	4	WASHER				
16	409154	4	WASHER				
17	409161	2	WASHER				
18	409175	4	WASHER				
19	409179	1	WASHER				
20	409230	1	WASHER				
21	410292	2	CLAMP				
22	410409	1	PLUG				
23	410442	1	RING NUT				
24	415945	1	WASHER				
25	416158	1	KNOB				
26	428807	1	SCREW				
27	436119	1	BUSHING				

10059467-AA

01

CR-01 GROUP BASE BRUSH CYLINDER 500SS

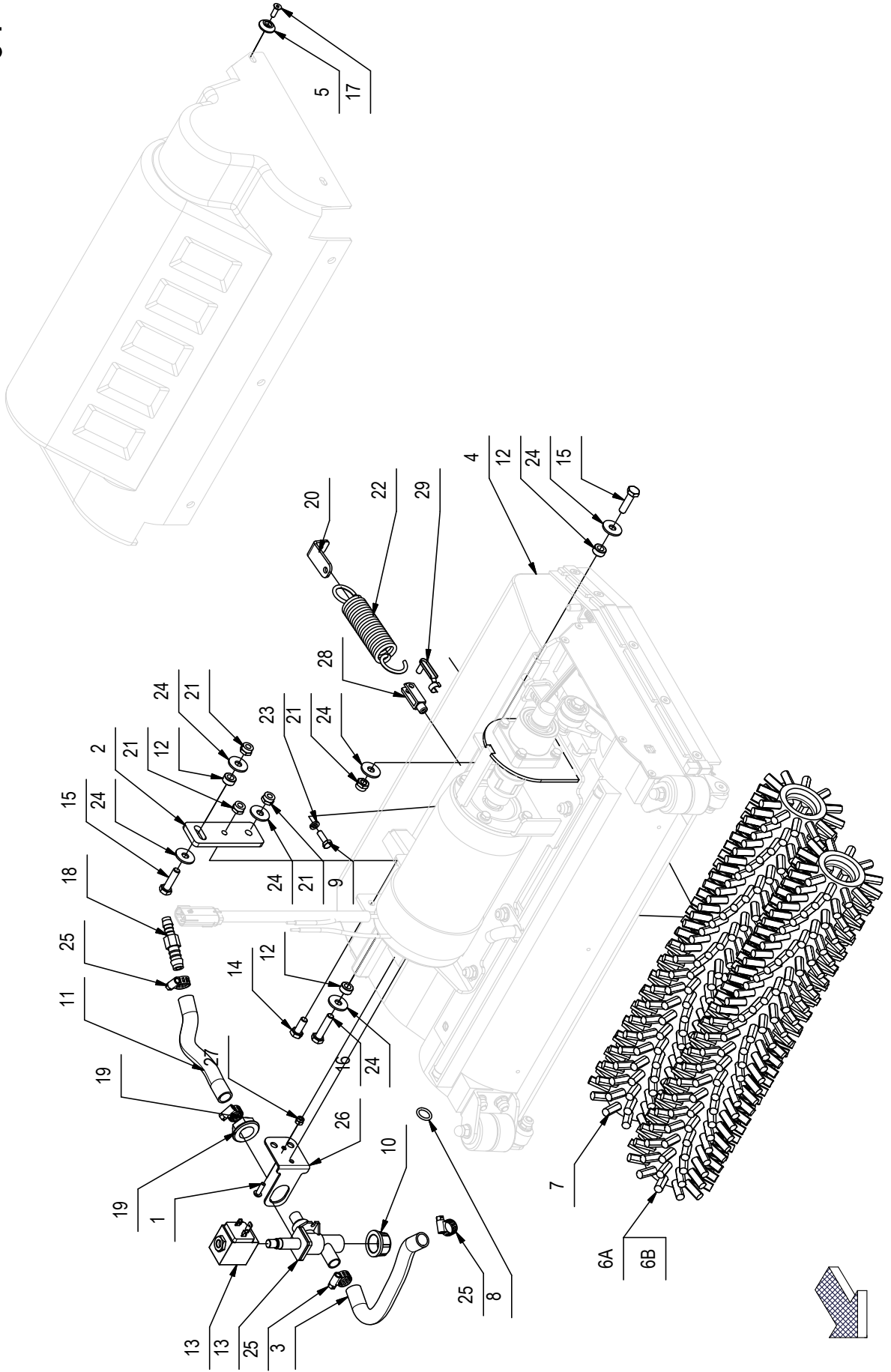

CR-01 GROUP BASE BRUSH CYLINDER 500SS

POS	CODE	Q.TY	DENOMINATION
1	415849	2	SCREW
2	203532	1	PLAQUE
3	202140	1	PIPE
4	225236	1	CYLINDRICAL BRUSH BASE
5	400250	7	SPECIAL WASHER
6A	405639	1	FRONT BRUSH
6B	405641	1	FRONT BRUSH
7	405640	1	REAR BRUSH
8	408595	1	GASKET
9	407665	1	SCREW
10	410409	1	PLUG
11	217000	1	HOSE
12	408041	3	BUSHING
13	407887	1	SOLENOID VALVE
14	408670	1	SCREW
15	408676	2	SCREW
16	408678	1	SCREW
17	408957	7	SCREW
18	434520	1	FITTING
19	410442	1	RING NUT
20	439824	1	SUPPORT
21	409085	4	LOCK NUT
22	202482	1	SPRING
23	409164	1	LOCK WASHER
24	409179	6	WASHER
25	410292	4	CLAMP
26	220892	1	SUPPORT
27	409081	2	LOCK NUT
28	410455	1	FORK
29	410463	1	CLIP

10059461-AA

01A

CR-01A PREASSEMBLY BASE BRUSH CYLINDER 500SS

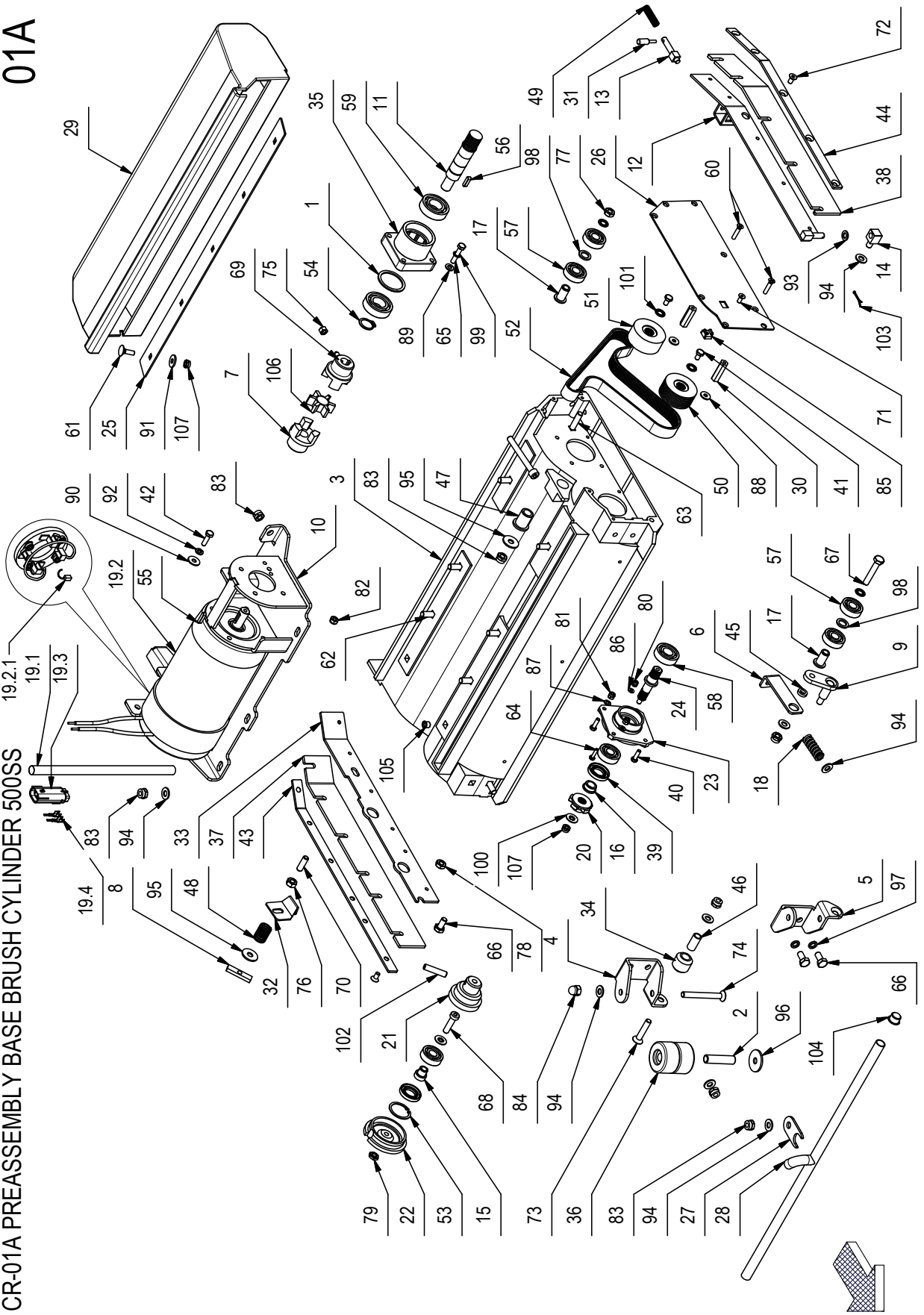

CR-01A PREASSEMBLY BASE BRUSH CYLINDER 500SS

01A



POS	CODE	Q.TY	DENOMINATION	POS	CODE	Q.TY	DENOMINATION	POS	CODE	Q.TY	DENOMINATION	POS	CODE	Q.TY	DENOMINATION
1	202449	1	SPACER	31	400832	1	PIN	64	408648	2	SCREW	99	409336	4	WASHER
2	203346	2	PIPE	32	400833	1	BLADE	65	408659	4	SCREW	100	409338	4	WASHER
3	203533	1	TUNNEL	33	400834	1	RIGHT SUPPORT	66	408669	3	SCREW	101	409342	4	LOCK WASHER
4	203534	1	RIGHT SUPPORT WHEEL	34	400835	2	WHEEL	67	408681	1	SCREW	102	409380	2	SPRING PIN
5	203535	1	LEFT SUPPORT WHEEL	35	400845	1	BEARING SUPPORT	68	408821	2	SCREW	103	409383	1	SPLIT PIN
6	203536	1	TIE ROD	36	405707	4	WHEEL	69	408909	2	DOWEL	104	409832	2	CAP
7	203537	2	HUB	37	406050	1	SPLASH GUARD 33 SH	70	408913	1	DOWEL	105	409846	2	PLUG
8	206519	1	WING NUT				RIGHT	71	408963	5	SCREW	106	410561	1	FLEXIBLE COUPLING
9	206798	1	ARM	38	406051	1	SPLASH GUARD 33 SH	72	408979	11	SCREW	107	415901	7	NUT
10	206799	1	MOTOR SUPPORT				LEFT	73	408983	2	SCREW	108	418302	1	SCREW
11	206800	1	SHAFT MOTOR PULLEY	39	407608	4	OIL SEAL	74	408995	2	SCREW				
12	206801	1	LEFT SUPPORT	40	407646	6	SCREW	75	409039	2	NUT				
13	206802	1	PIN	41	407657	2	SCREW	76	409046	1	NUT				
14	206803	1	LEFT SUPPORT	42	407666	4	SCREW	77	409048	1	NUT				
15	210198	2	BUSHING	43	407956	1	RIGHT BLADE	78	409054	1	NUT				
16	210199	2	BUSHING	44	407957	1	LEFT BLADE	79	409057	2	NUT				
17	210200	2	BUSHING	45	407991	1	SPACER	80	409079	2	NUT				
18	210206	1	SPRING	46	408021	2	BUSHING	81	409081	4	LOCK NUT				
19	225232	1	MOTOR ASSEMBLY	47	408089	1	BUSHING	82	409082	4	LOCK NUT				
19.1	222407	1	SHEATH	48	408107	1	SPRING	83	409085	13	LOCK NUT				
19.2	407717	1	MOTOR	49	408108	1	SPRING	84	409110	2	CAP NUT M8 ZNT				
19.2.1	409420	4	CARBON BRUSH MOTOR	50	408160	1	PULLEY	85	409117	1	NUT				
19.3	436411	1	CONNECTOR FEMALE	51	408162	1	PULLEY	86	409143	2	WASHER				
19.4	436413	2	CONTACT	52	408322	1	BELT	87	409149	4	WASHER				
20	400821	2	HUB	53	408338	2	RING	88	409151	2	WASHER				
21	400822	2	RIGHT HUB	54	408356	1	SEEGER RING	89	409156	4	WASHER				
22	400823	2	RIGHT HUB	55	408402	1	KEY	90	409160	4	WASHER				
23	400824	2	BEARING SUPPORT	56	408403	1	KEY	91	409161	5	WASHER				
24	400825	2	SHAFT LEFT	57	408422	8	BEARING	92	409164	4	LOCK WASHER				
25	400826	1	BLADE	58	408427	2	BEARING	93	409173	1	WASHER				
26	400827	1	COVER	59	408434	2	BEARING	94	409175	15	WASHER				
27	400828	1	PLAQUE	60	408515	2	SCREW	95	409179	2	WASHER				
28	400829	1	PIPE	61	408622	5	SCREW	96	409180	2	WASHER				
29	400830	1	HOPPER	62	408628	8	SCREW	97	409181	2	LOCK WASHER				
30	400831	2	STUD BOLT	63	408629	1	SCREW	98	409208	2	WASHER BRASS				

10038121 - AB

03

CR-03 SQUEEGEE ASSEMBLY

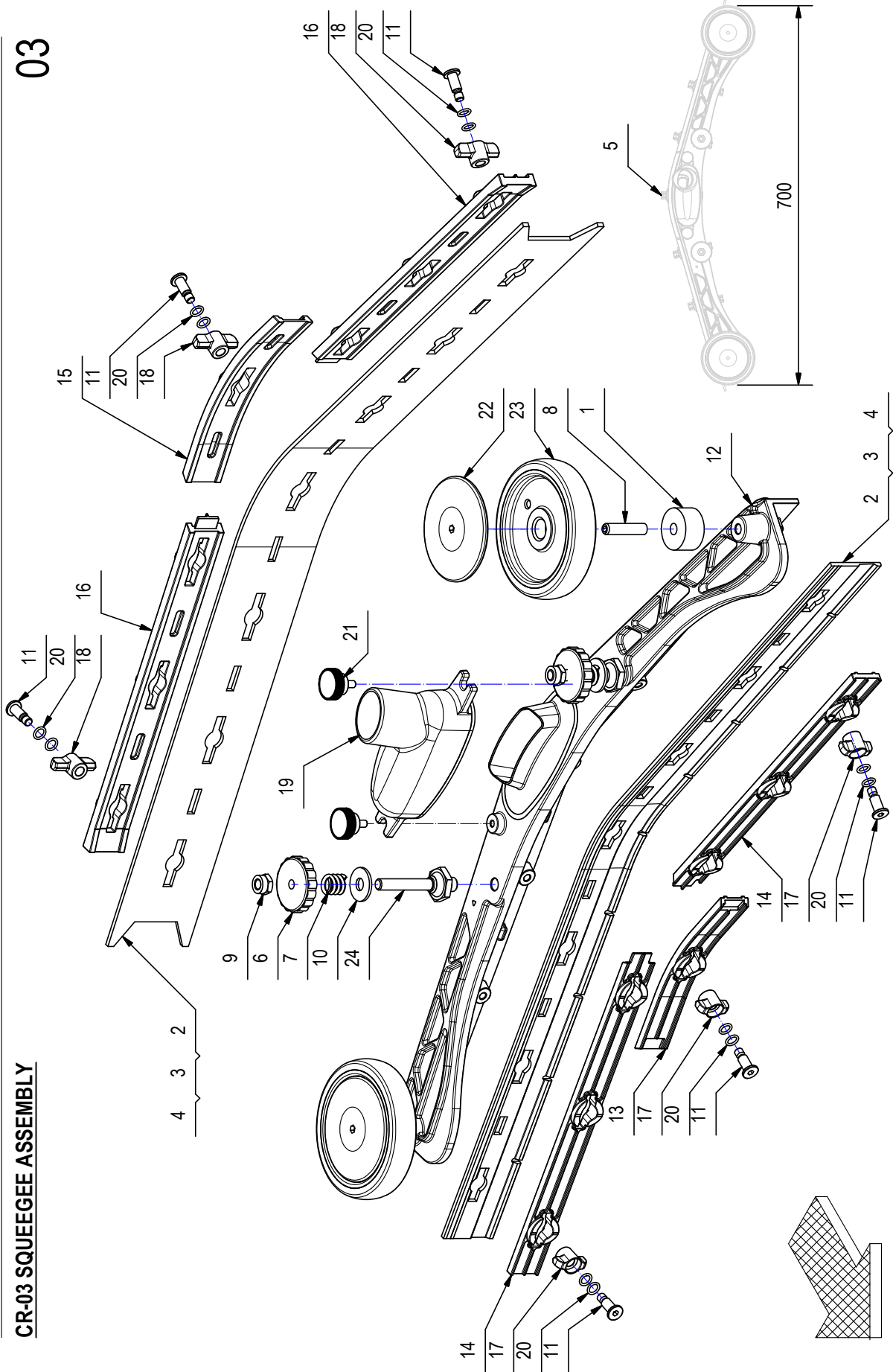

CR-03 SQUEEGEE ASSEMBLY

POS.	CODE	Q.TY	DENOMINATION
1	214071	2	SPACER
2	219451	1	KIT RUBBER IN PARA 33Sh
3	219452	1	POLYURETHANE RUBBER KIT
4	219453	1	KIT RUBBER LATEX
5	222875	1	SQUEEGEE ASSEMBLY
6	400112	2	HANDWHEEL
7	408098	2	SPRING
8	408915	2	DOWEL
9	409087	2	LOCK NUT
10	409185	2	WASHER
11	430903	14	PIN
12	430940	1	SQUEEGEE BODY
13	430944	1	FRONT BLADE
14	430945	2	FRONT BLADE
15	430949	1	REAR BLADE
16	430950	2	REAR BLADE
17	430954	7	WING NUT
18	430955	7	WING NUT
19	430957	1	OPENING
20	431633	28	O-RING
21	435330	2	KNOB
22	436119	2	BUSHING
23	436120	2	BUMPER
24	437851	2	STUD BOLT

CR-04 SQUEEGEE CONTROL ASSEMBLY

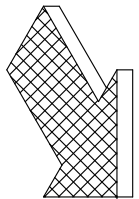
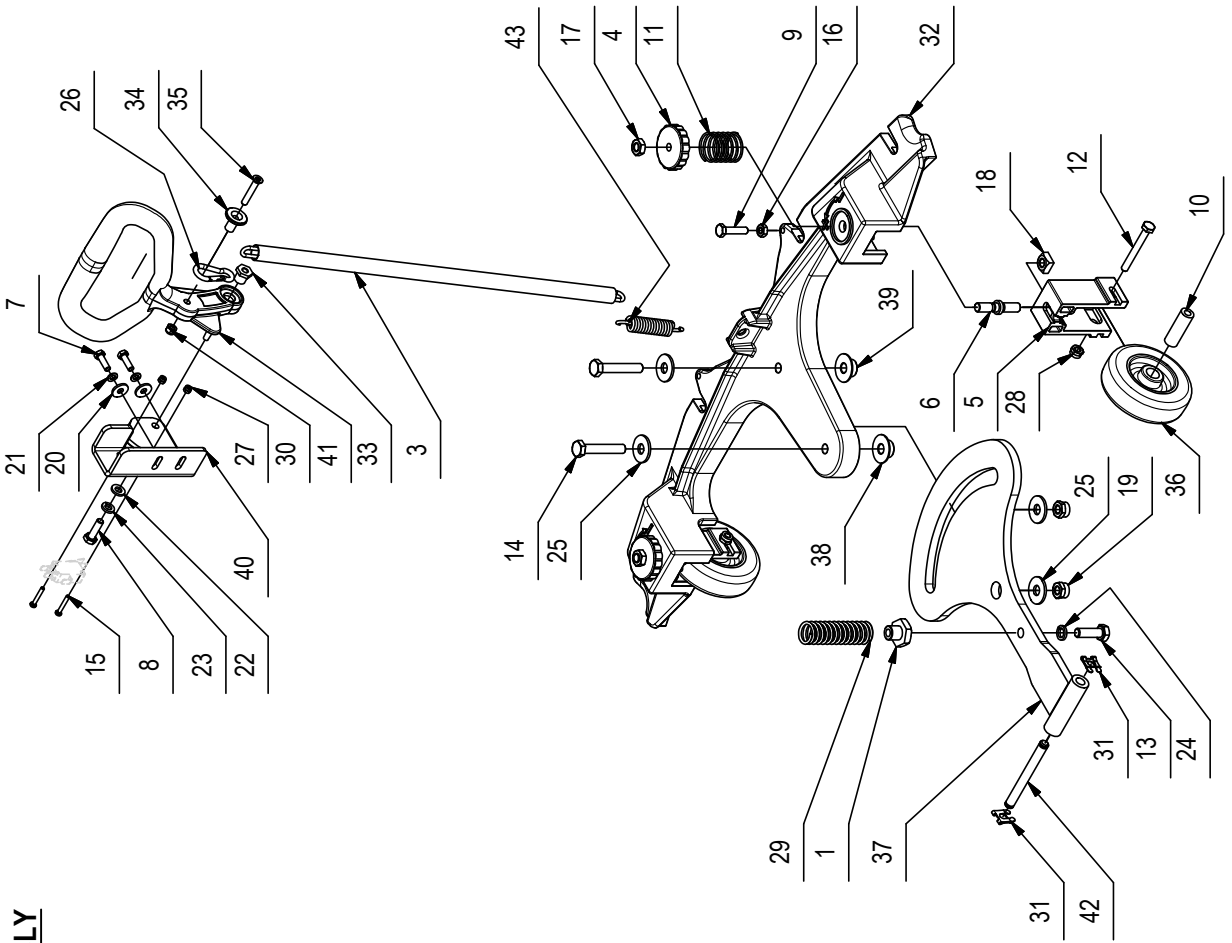

CR-04 SQUEEGEE CONTROL ASSEMBLY

POS.	CODE	Q.TY	DENOMINATION	POS.	CODE	Q.TY	DENOMINATION
1	202467	1	BUSHING	39	439922	1	BUSHING
2	224489	1	CHAIN	40	441601	1	SUPPORT
3	224885	1	SHEATH	41	441605	1	LEVER
4	400112	2	HANDWHEEL	42	441678	1	PIN
5	400839	2	SUPPORT	43	408112	1	SPRING
6	400841	2	PIN				
7	407645	2	SCREW				
8	407666	1	SCREW				
9	407670	1	SCREW				
10	408086	2	SPACER				
11	408092	2	SPRING				
12	408657	2	SCREW				
13	408674	1	SCREW				
14	408695	2	SCREW				
15	408834	2	SCREW				
16	409044	1	NUT				
17	409048	2	NUT				
18	409055	2	NUT				
19	409087	2	LOCK NUT				
20	409151	2	WASHER				
21	409155	2	WASHER				
22	409156	1	WASHER				
23	409164	1	LOCK WASHER				
24	409181	1	LOCK WASHER				
25	409185	4	WASHER				
26	433682	1	CARABINIER				
27	415897	2	LOCK NUT				
28	415901	2	NUT				
29	416727	1	SPRING				
30	416781	1	LOCK NUT				
31	422570	2	SPRING				
32	437134	1	REAR ARM				
33	438056	1	BUSHING				
34	438106	1	BUSHING				
35	438304	1	SCREW				
36	438487	2	WHEEL				
37	439920	1	FRONT ARM				
38	439921	1	BUSHING				

CR-02/05 CONTROL BASE AND FRAME ASSEMBLY 500RS

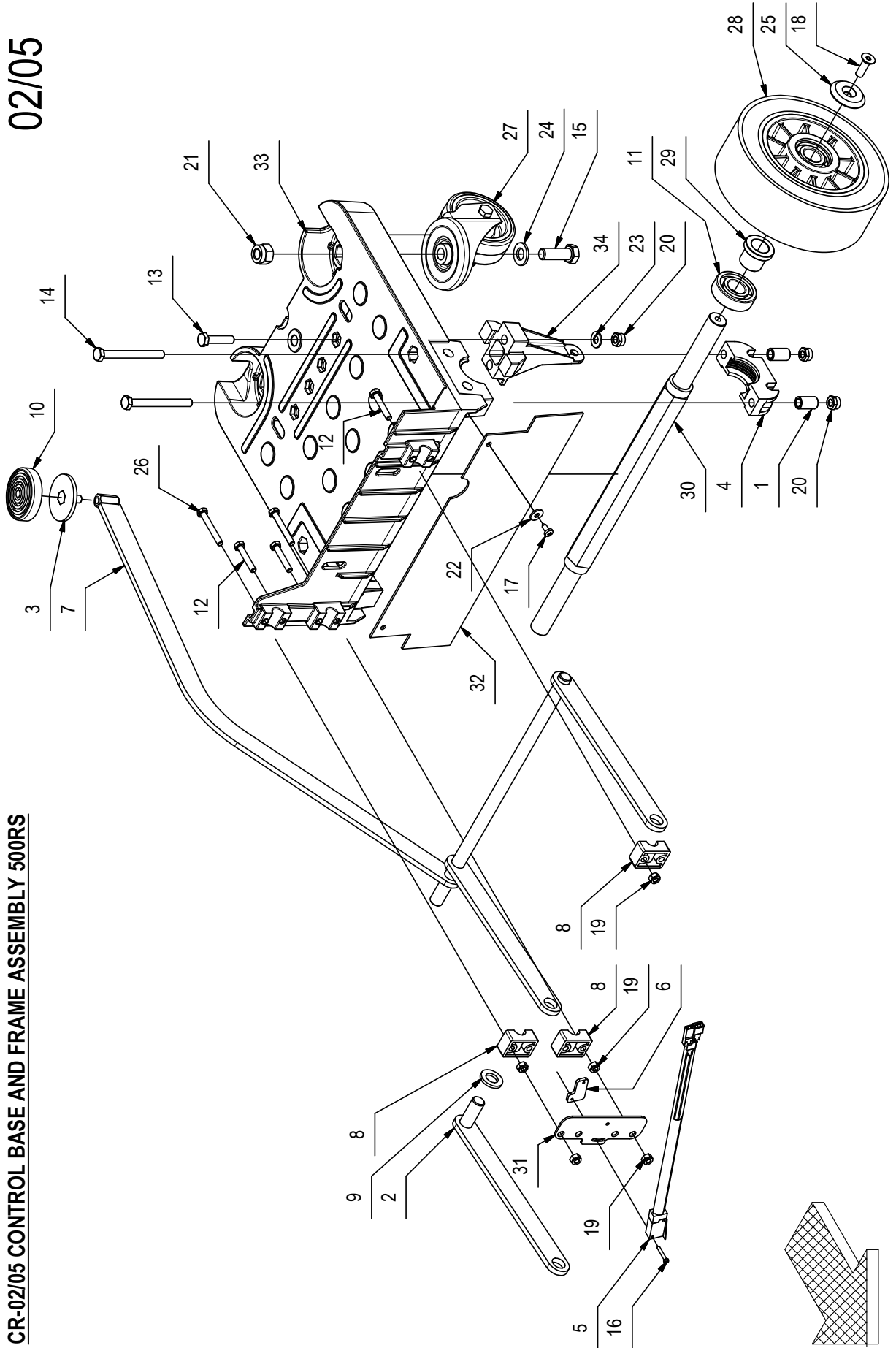

CR-02/05 CONTROL BASE AND FRAME ASSEMBLY 500RS

POS.	CODE	Q.TY	DENOMINATION
1	202466	4	BUSHING
2	206831	1	ARM
3	206838	1	PEDAL
4	210489	2	BEARING SUPPORT
5	216999	1	MICROSWITCH
6	219111	1	SUPPORT
7	224771	1	ARM
8	400321	3	HOLDFAST
9	400322	1	WASHER
10	400773	1	PEDAL COVER
11	408435	2	BEARING
12	408651	4	SCREW
13	408678	4	SCREW
14	408687	4	SCREW
15	408746	2	SCREW
16	408834	2	SCREW
17	408883	2	SCREW
18	408986	2	SCREW
19	409082	8	LOCK NUT
20	409085	8	LOCK NUT
21	409093	2	NUT
22	409151	2	WASHER
23	409175	4	WASHER
24	409201	2	WASHER
25	415250	2	WASHER
26	415719	2	SCREW
27	424462	2	CASTOR WHEEL
28	436222	2	WHEEL
29	439923	2	SPACER
30	441523	1	SHAFT
31	441524	1	SUPPORT
32	441525	1	RUBBER
33	441526	1	FRAME
34	441527	2	SUPPORT

10056609 - AA

02/05

CR-02/05 CONTROL BASE AND FRAME ASSEMBLY 500RSX - 500SS

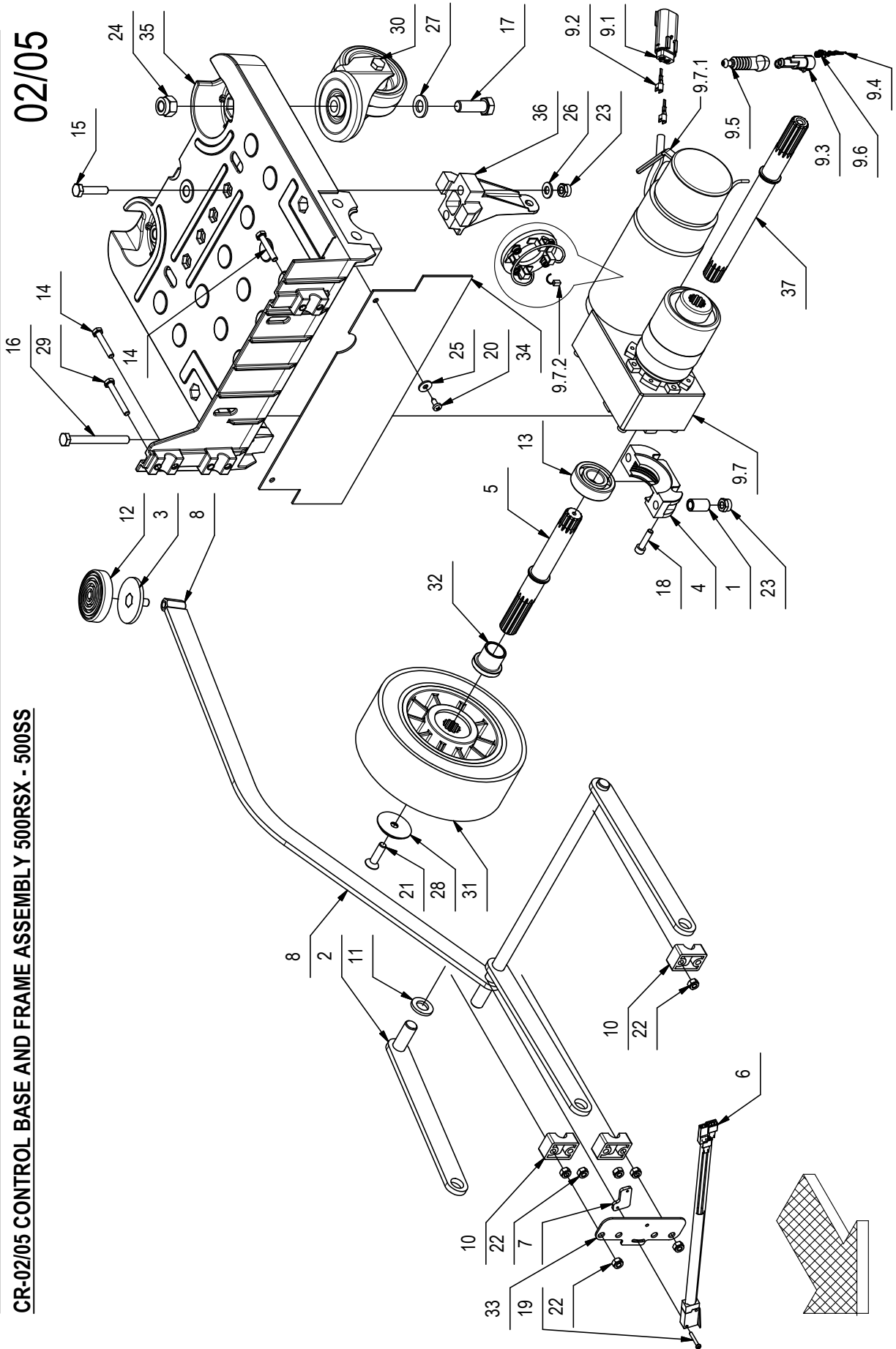

02/05

CR-02/05 CONTROL BASE AND FRAME ASSEMBLY 500RSX - 500SS

POS.	CODE	Q.TY	DENOMINATION	POS.	CODE	Q.TY	DENOMINATION
1	202466	4	BUSHING	30	424462	2	CASTOR WHEEL
2	206831	1	ARM	31	438029	2	WHEEL
3	206838	1	PEDAL	32	439923	2	SPACER
4	210489	2	BEARING SUPPORT	33	441524	1	SUPPORT
5	216811	1	LEFT AXLE SHAFT	34	441525	1	RUBBER
6	216999	1	MICROSWITCH	35	441526	1	FRAME
7	219111	1	SUPPORT	36	441527	2	SUPPORT
8	224771	1	ARM	37	441832	1	RIGHT AXLE SHAFT
9	224910	1	GEARED MOTOR				
9.1	436411	1	CONNECTOR FEMALE				
9.2	436413	2	CONTACT				
9.3	436430	1	CONNECTOR FEMALE				
9.4	436431	2	CONTACT				
9.5	436585	1	BELLOWS				
9.6	438589	2	GASKET				
9.7	441833	1	GEARED MOTOR				
9.7.1	441659	1	ELECTROBRAKE				
9.7.2	409413	2	CARBON BRUSH MOTOR				
10	400321	3	HOLDFAST				
11	400322	1	WASHER				
12	400773	1	PEDAL COVER				
13	408435	2	BEARING				
14	408651	4	SCREW				
15	408678	4	SCREW				
16	408687	4	SCREW				
17	408746	2	SCREW				
18	408797	4	SCREW				
19	408834	2	SCREW				
20	408883	2	SCREW				
21	408982	2	SCREW				
22	409082	8	LOCK NUT				
23	409085	8	LOCK NUT				
24	409093	2	NUT				
25	409151	2	WASHER				
26	409175	4	WASHER				
27	409201	2	WASHER				
28	415250	2	WASHER				
29	415719	2	SCREW				

CR-06/07 TANK ASSEMBLY

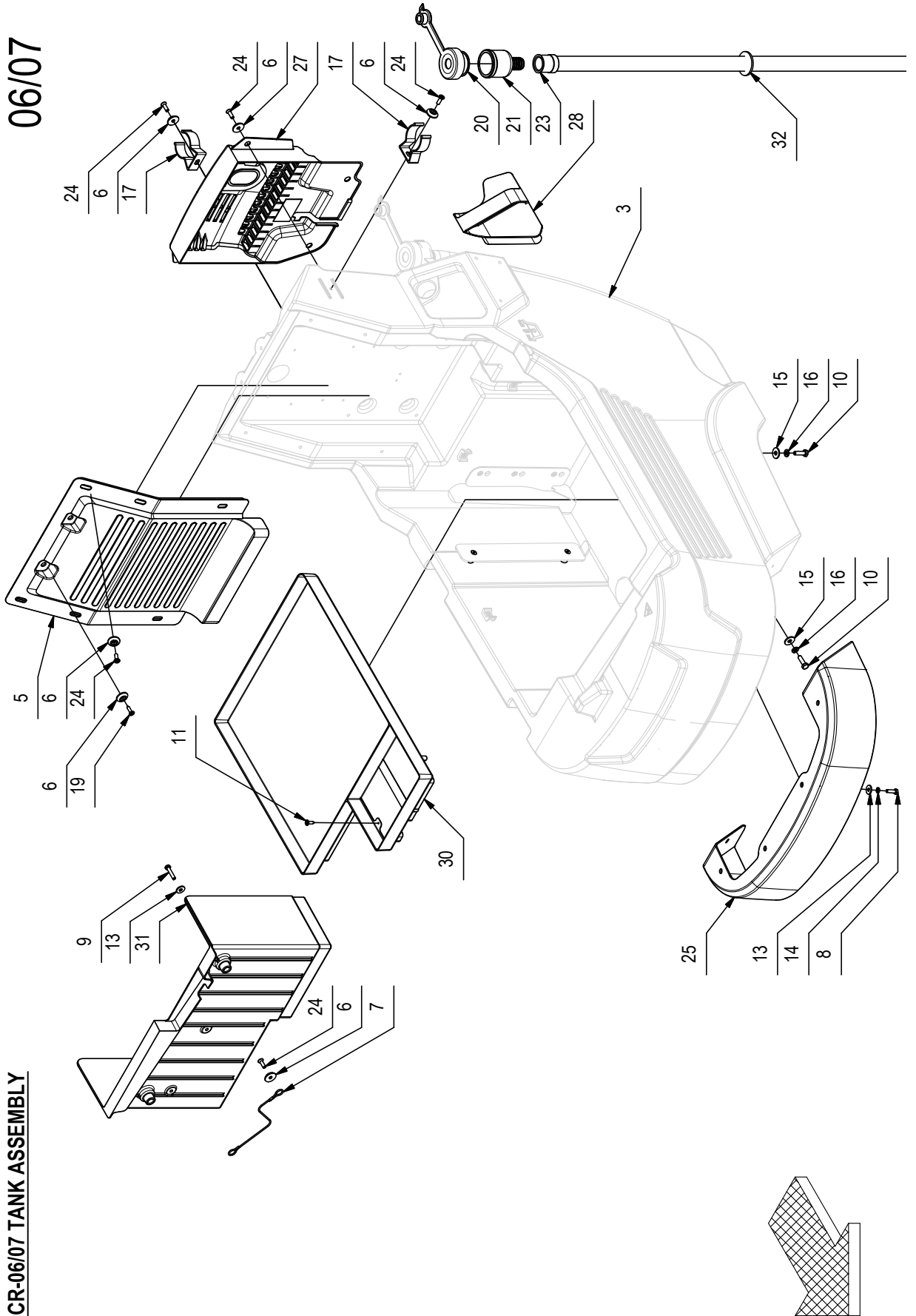

06/07

**CR-06/07 TANK ASSEMBLY**

POS.	CODE	Q.TY	DENOMINATION
1	224484	1	GASKET
2	225206	1	COVER
2.1	440886	2	SCREW
2.2	442507	1	COVER
2.3	442508	1	HOOK
3	225204	1	SOLUTION TANK PREASSEMBLY
4	225203	1	RECOVERY TANK ASSY
5	225266	1	CARTER
6	400250	16	SPECIAL WASHER
7	400653	1	STRING
8	407645	6	SCREW
9	407651	2	SCREW
10	407666	4	SCREW
11	408954	3	LOCK SCREW
12	409150	8	WASHER
13	409151	8	WASHER
14	409154	6	WASHER
15	409160	4	WASHER
16	409164	4	LOCK WASHER
17	412123	2	SPRING
18	415755	8	SCREW
19	425622	2	SCREW
20	426342	1	CAP
21	433650	1	FITTING
22	434159	2	HINGE
23	436261	1	PIPE
24	438302	14	SCREW
25	442506	1	CARTER
26	441559	1	SUCTION HOSE
27	442592	1	CARTER
28	441567	1	LEVEL PLUG
30	441591	1	BATTERY BASE
31	441592	1	COMPARTMENT TANK
32	405919	1	GASKET

CR-06/07 TANK ASSEMBLY

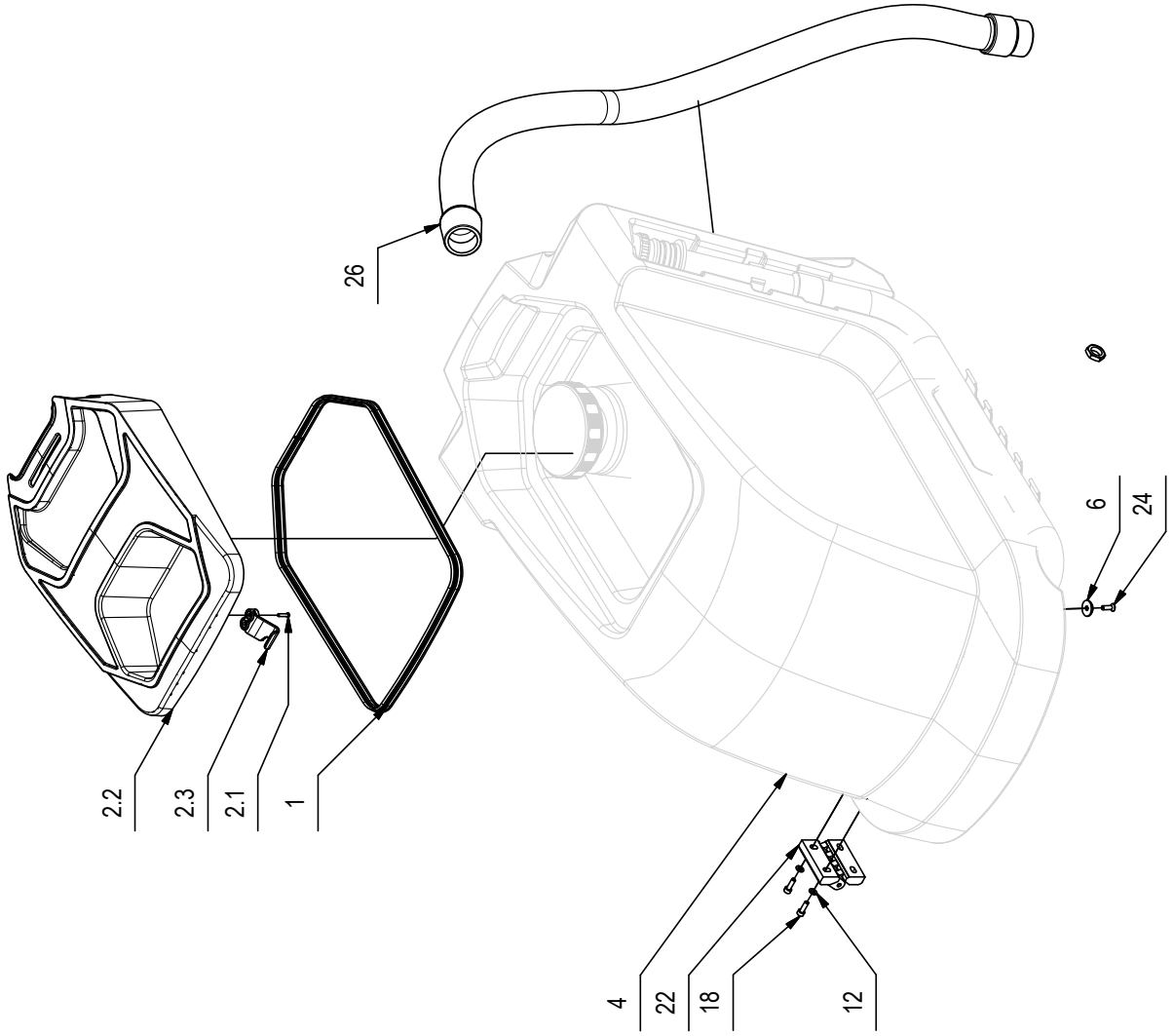

06/07

**CR-06/07 TANK ASSEMBLY**

POS.	CODE	Q.TY	DENOMINATION
1	224484	1	GASKET
2	225206	1	COVER
2.1	440886	2	SCREW
2.2	442507	1	COVER
2.3	442508	1	HOOK
3	225204	1	SOLUTION TANK PREASSEMBLY
4	225203	1	RECOVERY TANK ASSY
5	225266	1	CARTER
6	400250	16	SPECIAL WASHER
7	400653	1	STRING
8	407645	6	SCREW
9	407651	2	SCREW
10	407666	4	SCREW
11	408954	3	LOCK SCREW
12	409150	8	WASHER
13	409151	8	WASHER
14	409154	6	WASHER
15	409160	4	WASHER
16	409164	4	LOCK WASHER
17	412123	2	SPRING
18	415755	8	SCREW
19	425622	2	SCREW
20	426342	1	CAP
21	433650	1	FITTING
22	434159	2	HINGE
23	436261	1	PIPE
24	438302	14	SCREW
25	442506	1	CARTER
26	441559	1	SUCTION HOSE
27	442592	1	CARTER
28	441567	1	LEVEL PLUG
30	441591	1	BATTERY BASE
31	441592	1	COMPARTMENT TANK
32	405919	1	GASKET

10059186 - AA

06

CR-06 SOLUTION TANK PREASSEMBLY

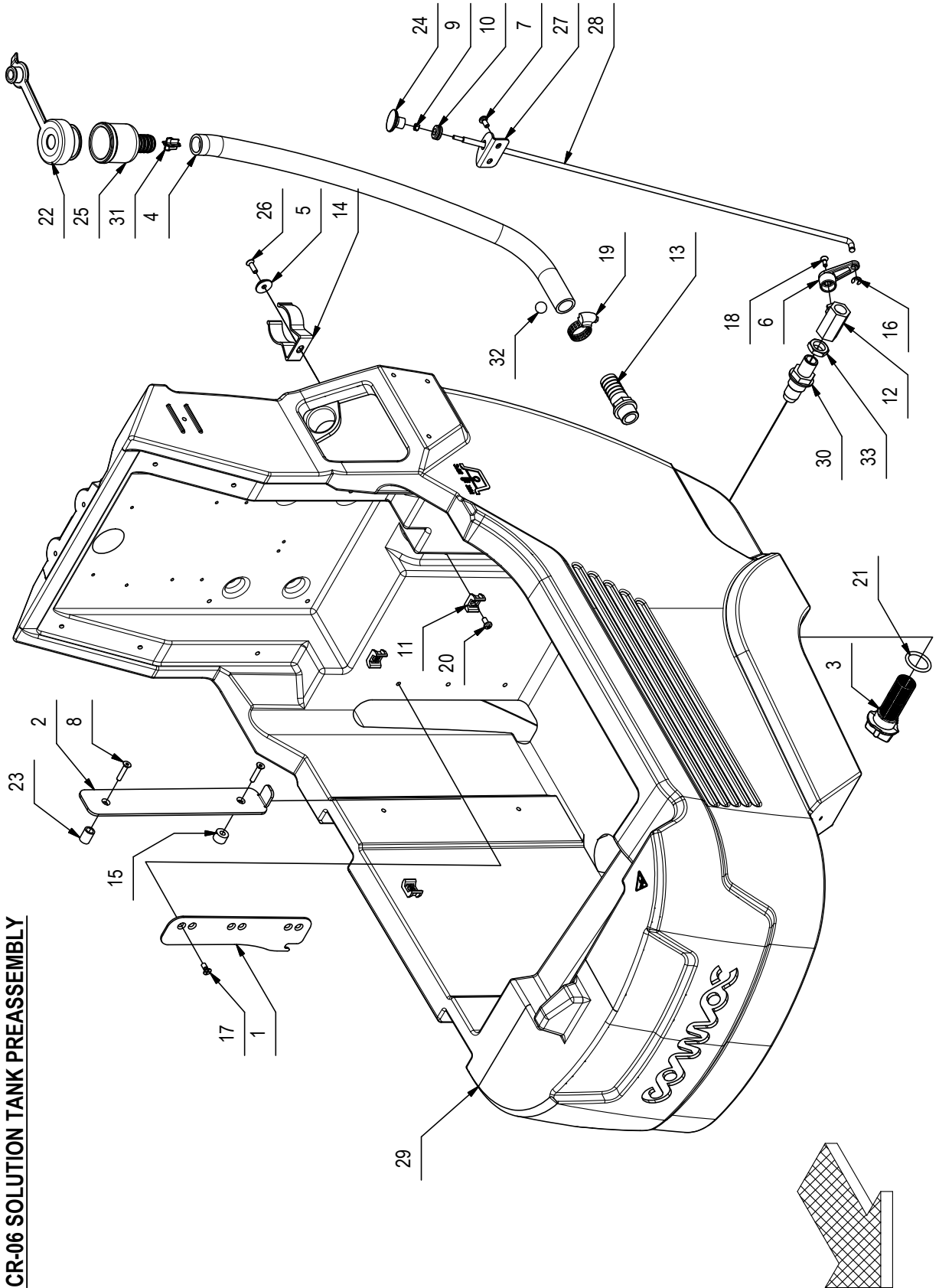

CR-06 SOLUTION TANK PREASSEMBLY

POS.	CODE	Q.TY	DENOMINATION
1	217089	1	SUPPORT
2	217245	1	SUPPORT
3	222092	1	FILTER
4	224157	1	PIPE
5	400250	1	SPECIAL WASHER
6	400854	1	COCK LEVER
7	408848	2	SCREW
8	408960	2	SCREW
9	409034	1	NUT
10	409810	1	FAIRLEAD
11	409819	6	SUPPORT PLATE
12	410332	1	COCK
13	410386	1	CONNECTOR
14	412123	1	SPRING
15	414688	1	SPACER
16	415637	1	STOP RING
17	415750	3	SCREW
18	415793	1	SCREW
19	416172	1	CLAMP
20	418311	6	SCREW
21	424451	1	O-RING
22	426342	1	CAP
23	427680	1	SPACER
24	433645	1	KNOB
25	433650	1	FITTING
26	438302	1	SCREW
27	440313	1	GUIDE
28	441018	1	ROD
29	442505	1	SOLUTION TANK
30	441529	1	NIPPLE
31	441789	1	STOP
32	441790	1	BALL
33	400160	1	NUT

CR-07 RECOVERY TANK PREASSEMBLY

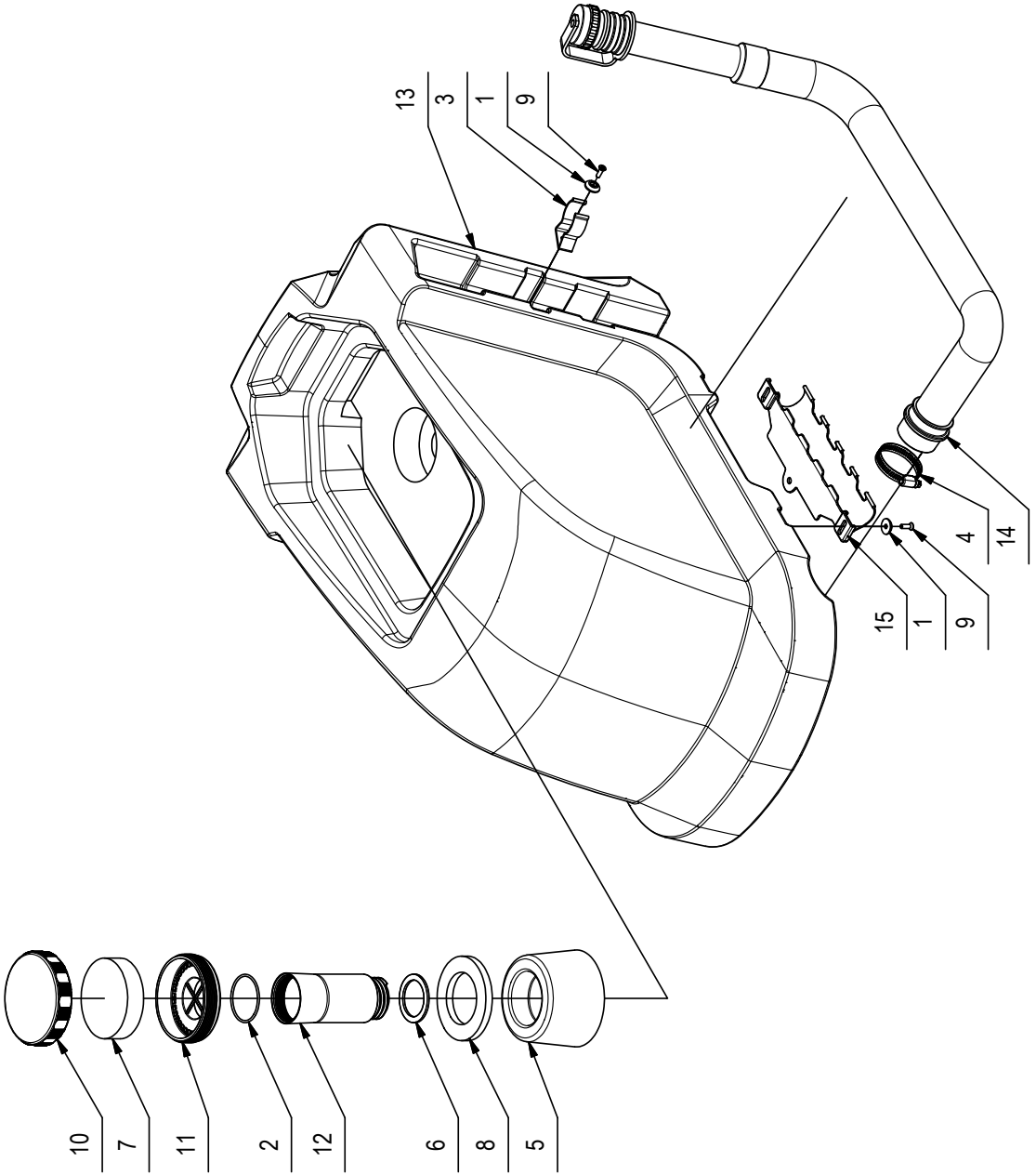

CR-07 RECOVERY TANK PREASSEMBLY

POS.	CODE	Q.TY	DENOMINATION
1	400250	4	SPECIAL WASHER
2	408687	1	O-RING
3	412123	1	SPRING
4	410287	1	CLAMP
5	436108	1	FLOAT
6	436195	1	GASKET
7	436361	1	FILTER
8	436779	1	RING
9	438302	4	SCREW
10	438864	1	COVER
11	438884	1	FLOAT
12	438885	1	FLOAT
13	442504	1	RECOVERY TANK
14	441530	1	EXHAUST PIPE
15	441553	1	SUPPORT

CR-08 SUCTION MOTOR ASSEMBLY

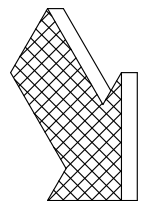
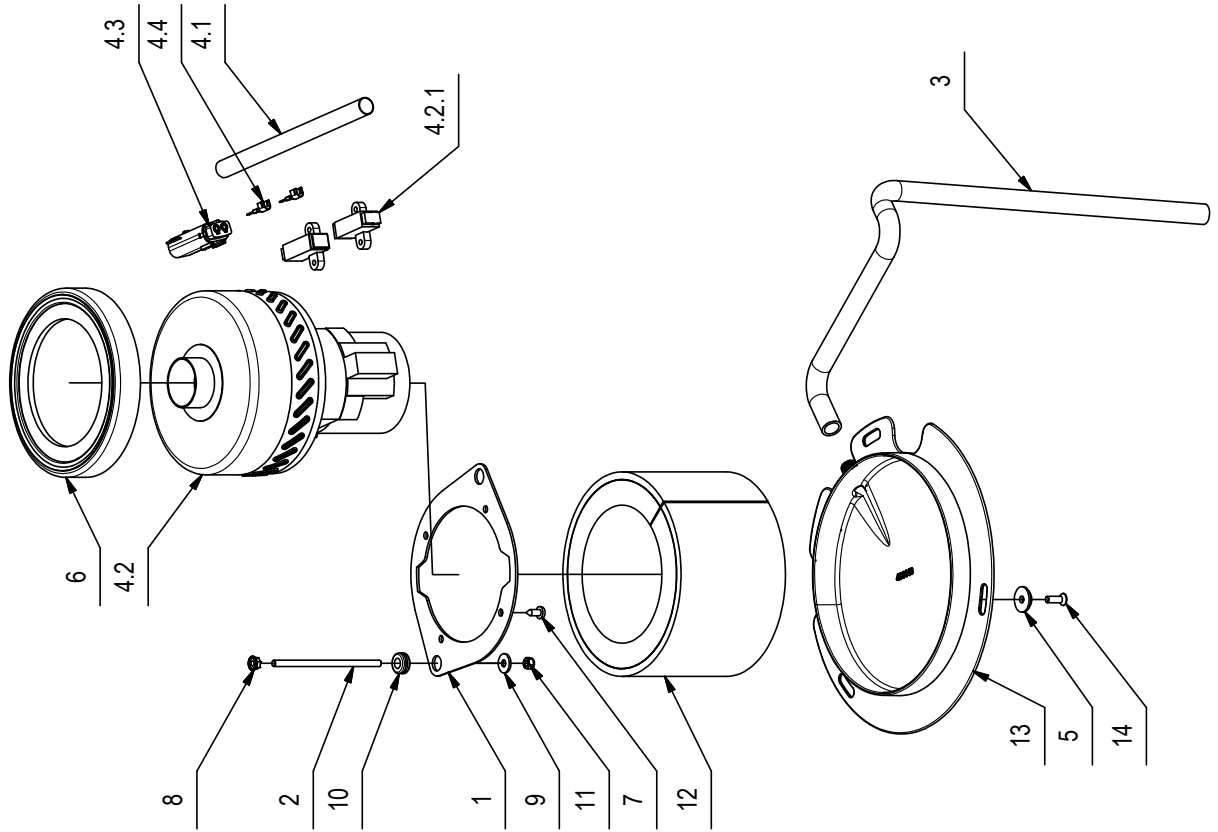

CR-08 SUCTION MOTOR ASSEMBLY

POS.	CODE	Q.TY	DENOMINATION
1	204233	1	PLAQUE
2	218967	2	ROD
3	222430	1	SHEATH
4	222453	1	SUCTION MOTOR
4.1	217530	1	SHEATH
4.2	430959	1	SUCTION MOTOR
4.2.1	424210	1	CARBON BRUSH MOTOR
4.3	436411	1	CONNECTOR FEMALE
4.4	436413	2	CONTACT
5	400250	3	SPECIAL WASHER
6	405936	1	SHROUD
7	408883	4	SCREW
8	409124	2	NUT
9	409151	2	WASHER
10	409810	2	FAIRLEAD
11	416781	2	LOCK NUT
12	433704	1	DEADENING
13	436113	1	COVER
14	438302	3	SCREW

10056567 - AA

CR-09 WATER UNIT

09

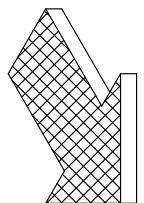
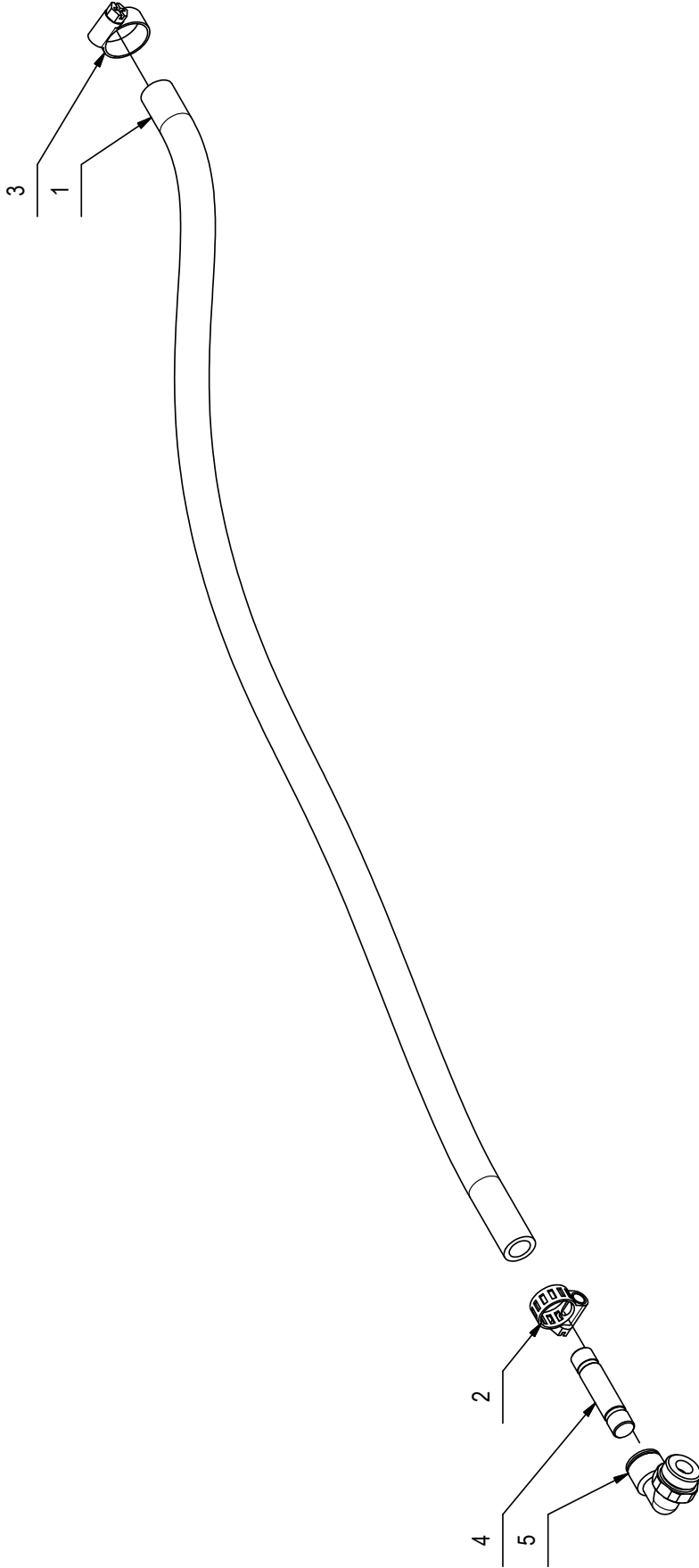

10056567 - AA

09

CR-09 WATER UNIT

POS.	CODE	Q.TY	DENOMINATION
1	225009	1	PIPE
2	410292	1	CLAMP
3	410297	1	CLAMP
4	441791	1	
5	441792	1	

10

CR-10 ELECTRIC COMPONENTS 500RS

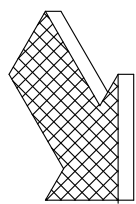
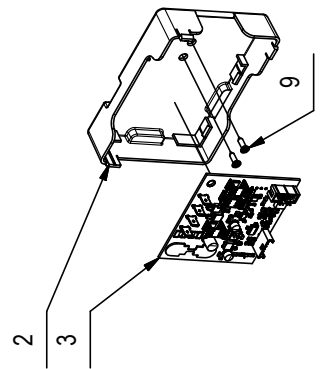
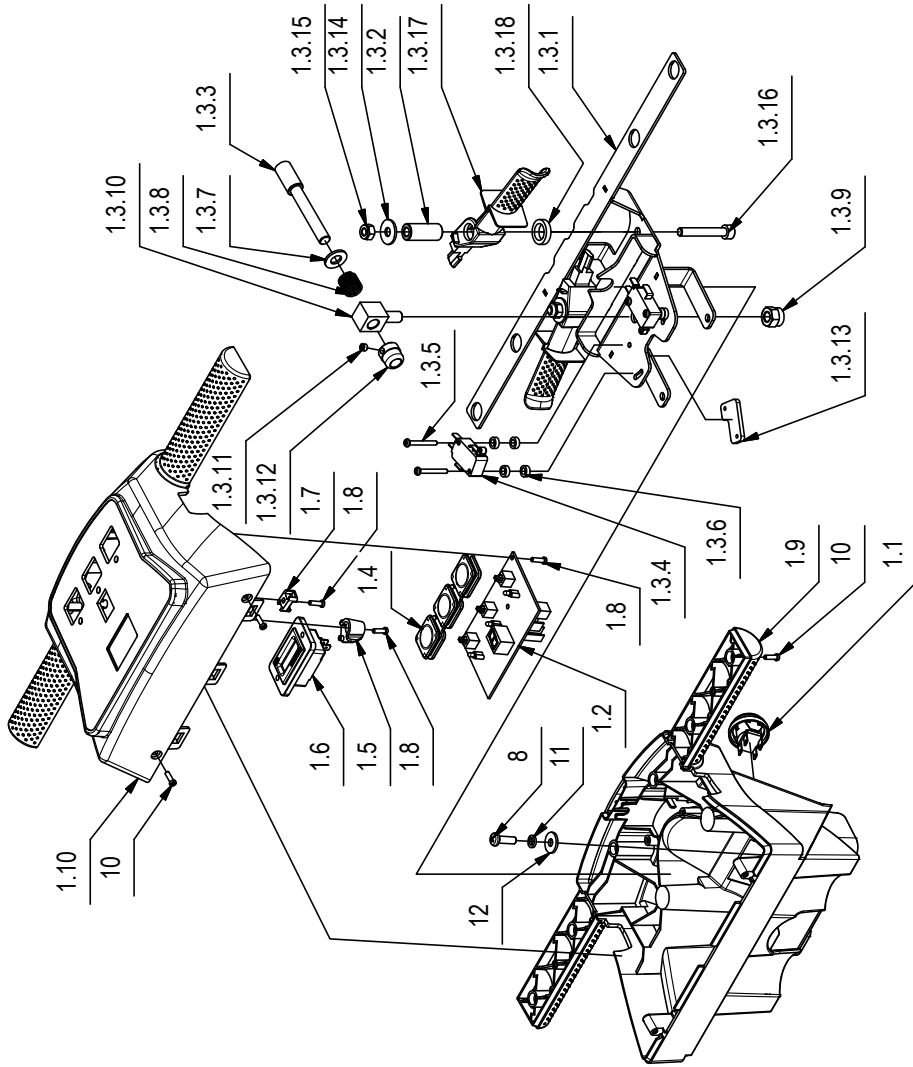

CR-10 ELECTRIC COMPONENTS 500RS

POS.	CODE	Q.TY	DENOMINATION	POS.	CODE	Q.TY	DENOMINATION
1	225267	1	PREASSEMBLY HANDLEBAR	10	440883	8	SCREW
1.1	441676	1	SWITCH	11	409154	5	WASHER
1.2	421244	1	CARD	12	409151	5	WASHER
1.3	224888	1	PREASSEMBLY CONTROL GEAR				
1.3.1	441645	1	REINFORCEMENT				
1.3.2	407992	2	PIN				
1.3.3	217013	1	PIN				
1.3.4	409491	2	MICROSWITCH				
1.3.5	408835	4	SCREW				
1.3.6	409148	8	WASHER				
1.3.7	409175	1	WASHER				
1.3.8	408109	1	SPRING				
1.3.9	409086	1	LOCK NUT				
1.3.10	204702	1	SUPPORT				
1.3.11	427880	1	DOWEL				
1.3.12	217020	1	BUSHING				
1.3.13	219111	2	SUPPORT				
1.3.14	409160	2	WASHER				
1.3.15	409082	2	LOCK NUT				
1.3.16	408802	2	SCREW				
1.3.17	441787	2	LEVER				
1.3.18	441700	2	WASHER				
1.4	441608	1	PUSH BUTTON				
1.5	441609	2	SUPPORT				
1.6	409772	1	HOUR METER				
1.7	416073	1	SUPPORT PLATE				
1.8	440883	7	SCREW				
1.9	442595	1	LOWER HANDLEBARS				
1.10	442594	1	UPPER HANDLE (VERS. B)				
2	423067	1	PANEL				
3	441670	1	CONTROL CARD				
4	430072	1	CABLE				
5	441673	1	CABLE				
6	441671	1	CABLE				
7	441675	1	CABLE				
8	408854	5	SCREW				
9	408952	2	SCREW				

10

CR-10 ELECTRIC COMPONENTS 500RSX - 500SS

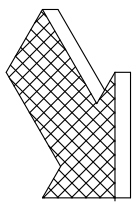
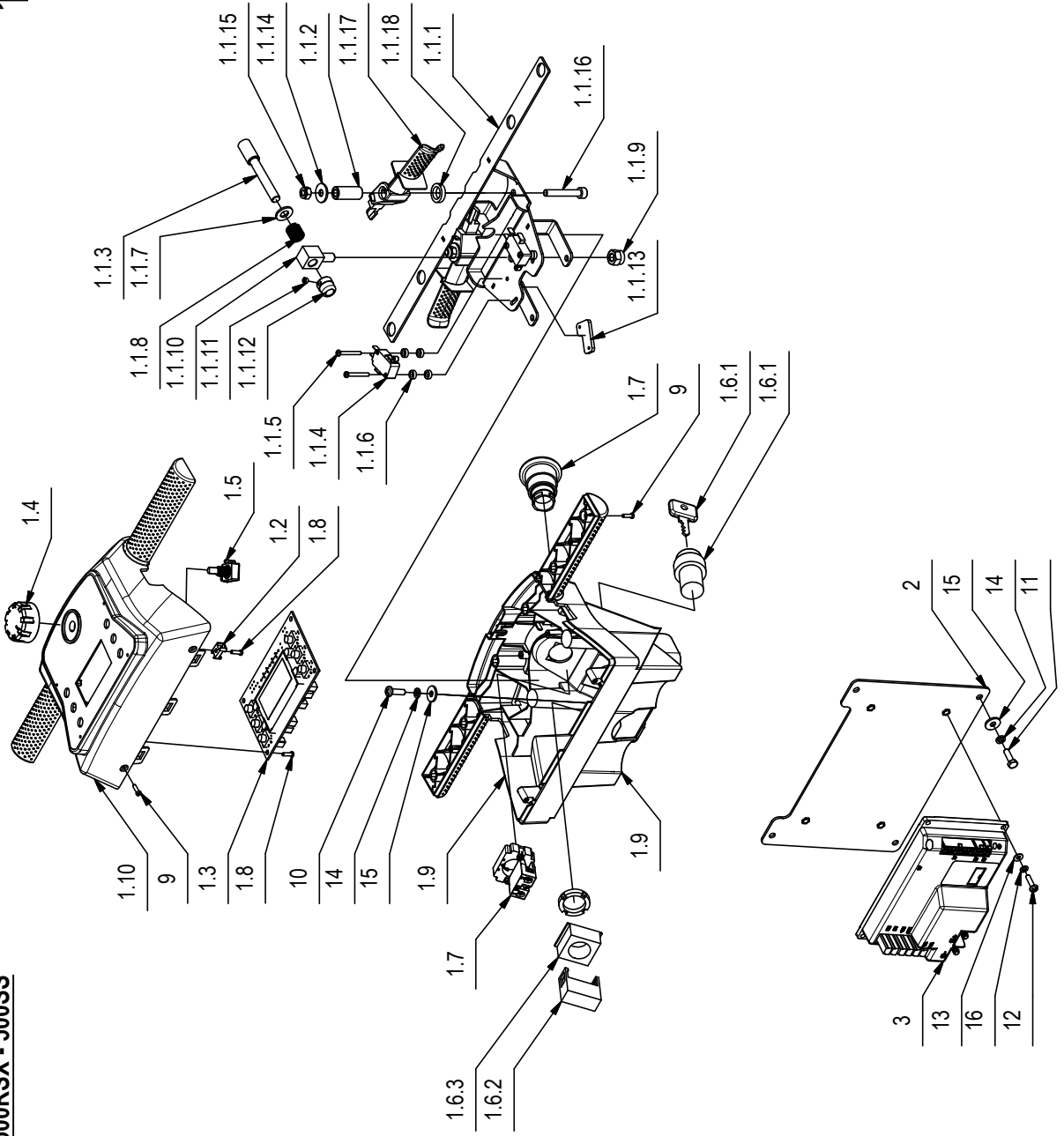

CR-10 ELECTRIC COMPONENTS 500RSX - 500SS

POS.	CODE	Q.TY	DENOMINATION	POS.	CODE	Q.TY	DENOMINATION
1	225263	1	HANDLE BAR ASSEMBLY	7	441847	1	CABLE
1.1	224888	1	PREASSEMBLY CONTROL	8	441864	1	CABLE
			GEAR	9	440883	8	SCREW
1.1.1	441645	1	REINFORCEMENT	10	408854	5	SCREW
1.1.2	407992	2	PIN	11	407645	4	SCREW
1.1.3	217013	1	PIN	12	408846	4	SCREW
1.1.4	409491	2	MICROSWITCH	13	409142	4	WASHER
1.1.5	408835	4	SCREW	14	409154	9	WASHER
1.1.6	409148	8	WASHER	15	409151	9	WASHER
1.1.7	409175	1	WASHER	16	415941	4	LOCK WASHER
1.1.8	408109	1	SPRING				
1.1.9	409086	1	LOCK NUT				
1.1.10	204702	1	SUPPORT				
1.1.11	427880	1	DOWEL				
1.1.12	217020	1	BUSHING				
1.1.13	219111	2	SUPPORT				
1.1.14	409160	2	WASHER				
1.1.15	409082	2	LOCK NUT				
1.1.16	408802	2	SCREW				
1.1.17	441787	2	LEVER				
1.1.18	441700	2	WASHER				
1.2	416073	1	SUPPORT PLATE				
1.3	438386	1	CARD				
1.4	438298	1	KNOB				
1.5	438158	1	POTENTIOMETER				
1.6	210516	1	KEY				
1.6.1	409261	1	SWITCH WITH KEY				
1.6.2	409246	1	CONTACT FOR SWITCH				
1.6.3	409262	1	FLANGE				
1.7	435489	1	PUSH BUTTON				
1.8	440883	5	SCREW				
1.9	442587	1	LOWER HANDLE				
1.10	442588	1	UPPER HANDLE				
2	441834	1	SUPPORT				
3	441843	1	CHECK CARD CONTROLS				
4	429721	1	CABLE				
5	441845	1	CABLE				
6	441846	1	CABLE				

10028628 AB

11

CR-11 GROUP CHARGER

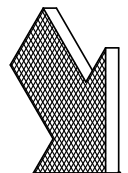
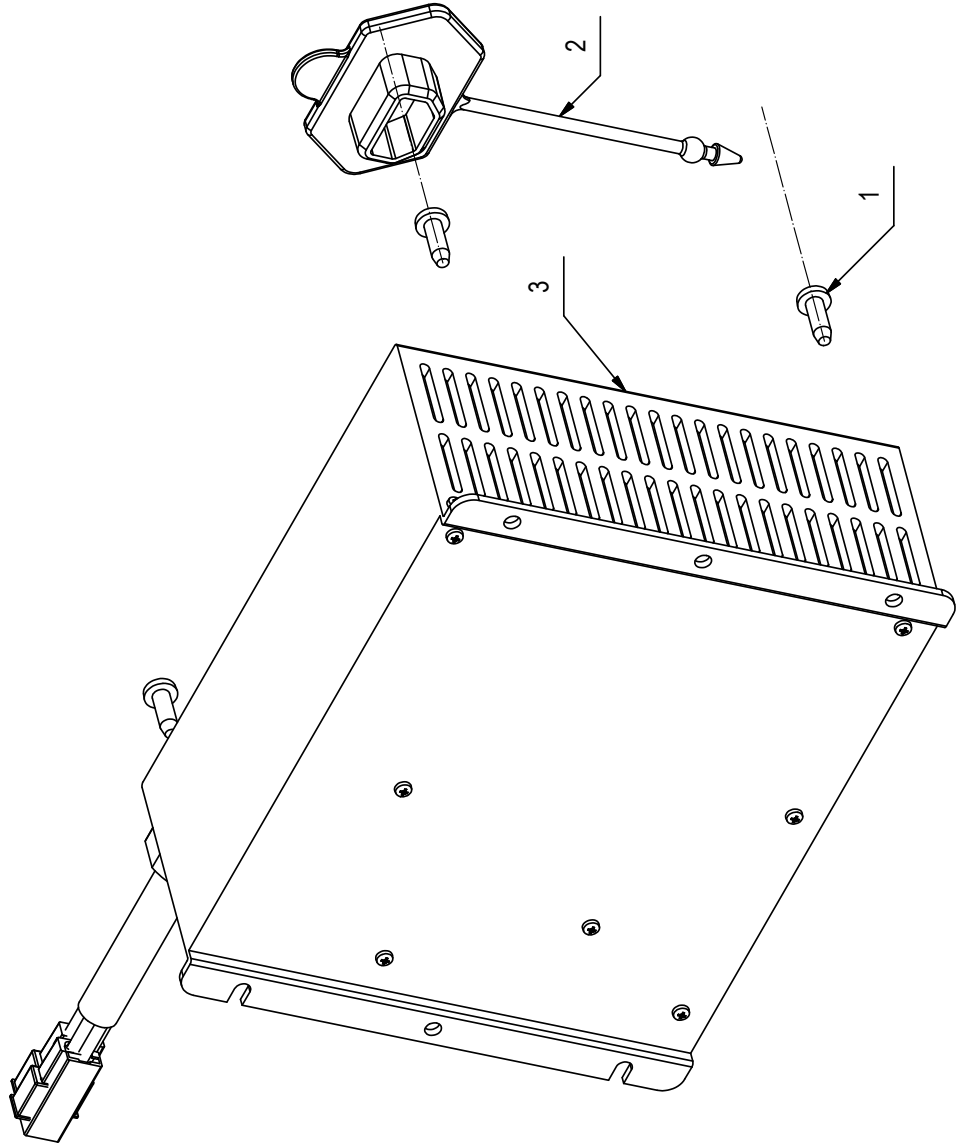

10028628 AB

11

CR-11 GROUP CHARGER

POS.	CODE	Q.TY	DENOMINATION
1	408880	4	SCREW
2	422893	1	PROTECTION
3	437657	1	BATTERY CHARGER 24V 11A

10059745-AA

15

CR-15 GROUP LABELS HAMMERHEAD 500RS



1

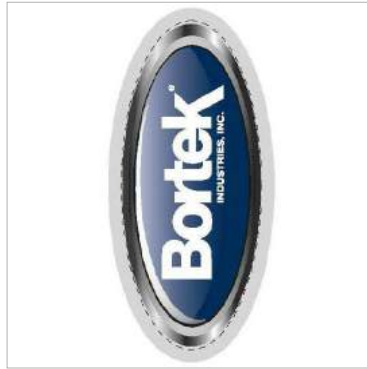

2



3



4

POS.	CODE	Q.TY	DENOMINATION
1	437703	1	LABEL WARNING COCK AND MAINTENANCE
2	439787	1	FRONT LABEL
3	442620	1	DASHBOARD LABEL
4	442623	1	KIT LABELS

CR-15 GROUP LABELS HAMMERHEAD 500RSX



4



3

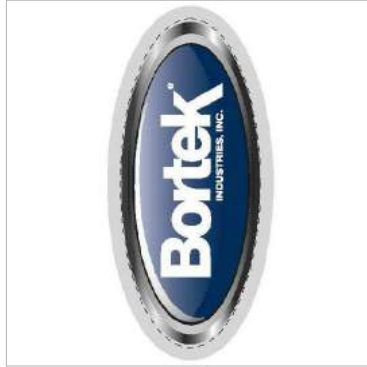

2



1

POS.	CODE	Q.TY	DENOMINATION
1	437703	1	LABEL WARNING COCK AND MAINTENANCE
2	439787	1	FRONT LABEL
3	442621	1	DASHBOARD LABEL
4	442624	1	KIT LABELS

10059747-AA

15

CR-15 GROUP LABELS HAMMERHEAD 500SS



1



2



3



4

POS.	CODE	Q.TY	DENOMINATION
1	437703	1	LABEL WARNING COCK AND MAINTENANCE
2	439787	1	FRONT LABEL
3	442622	1	DASHBOARD LABEL
4	442625	1	KIT LABELS

NOTE

A large rectangular area with a light gray background and horizontal lines, intended for handwritten notes. The lines are evenly spaced and extend across the width of the page.

NOTE

A large rectangular area with a light gray background and horizontal lines, intended for handwritten notes. The lines are evenly spaced and extend across the width of the page.



HAMMERHEAD®



450**RS**



500**RS** GEN II



500**RSX**



500**SS** GEN II



600**SS**



650**RS**



750**RS**



550**RDX**



650**RDX**



700**RSX**



750**RDX**



870**SR**



1100**SRX**

HEADQUARTERS

4713 Gettysburg Road
Mechanicsburg, PA 17055 USA

CONTACT US

☎ 800.6.Bortek

☎ 717.737.7591

✉ Orders@BortekIndustries.com

🌐 BortekIndustries.com/CUSTOMERLINK

SWEEPERLAND.COM

A complete family of
power cleaning machines.