



Flood Pumper™ Plus

Water Transfer Machine

Model No.:
607841

Operator and Parts Manual

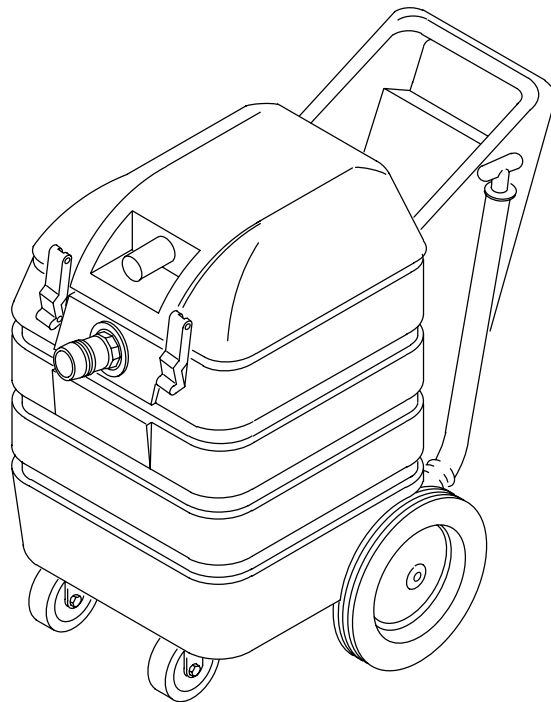

NOBLES
12875 RANSOM STREET
HOLLAND MI 49424 U.S.A.

CUSTOMER SERVICE: 1-800-365-6625
FAX: 1-800-678-4240

608468
Rev. 00 (11-99)

OPERATION

This manual is furnished with each new model. It provides necessary operating and preventative maintenance instructions and an illustrated parts list.

Read this manual completely and understand the machine before operating or servicing it.

When ordering replacement parts, use the parts lists section in this manual. Before ordering parts or supplies, be sure to have your machine model number and serial number available. Parts and supplies may be ordered by phone or mail from any authorized Service Center or Distributor.

This machine will provide excellent service. However, the best results will be obtained at minimum costs if:

- The machine is operated with reasonable care.
- The machine is maintained regularly - per the machine maintenance instructions provided.
- The machine is maintained with manufacturer supplied or equivalent parts.

MACHINE DATA

Please fill out at time of installation for future reference.

Model No.- _____

Install. Date - _____

Serial No.- _____

©1999 Tennant Company Printed in U.S.A.

Nobles is a registered United States trademark of Tennant Company. Flood Pumper is a United States trademark of Tennant.

Specifications and parts are subject to change without notice.

TABLE OF CONTENTS

SAFETY PRECAUTIONS	3
MACHINE COMPONENTS	4
SETUP AND OPERATION	4
MACHINE MAINTENANCE	5
STORING MACHINE	5
RECOMMENDED STOCK ITEMS	5
TROUBLESHOOTING	6
SPECIFICATIONS	6
ELECTRICAL DIAGRAM	7
PARTS LIST	8
RECOVERY TANK GROUP	8
VACUUM MOTOR / MACHINE BASE GROUP ...	10
DISCHARGE PUMP GROUP	12
HANDLE GROUP	14
FLOOR TOOL, HOSES AND	
SQUEEGEE GROUP	15

SAFETY PRECAUTIONS

This machine is intended for commercial use. It is designed to vacuum water in an indoor environment and is not constructed for any other use. Use only recommended accessories.

The following safety alert symbols are used throughout this manual as indicated in their description.

⚠ WARNING: To warn of hazards or unsafe practices which could result in severe personal injury or death.

FOR SAFETY: To identify actions which must be followed for safe operation of equipment.

The following information signals potentially dangerous conditions to the operator or equipment:

FOR SAFETY:

1. **Do not operate machine:**
 - Unless trained and authorized.
 - Unless operator manual is read and understood.
 - In flammable or explosive areas unless designed for use in those areas.
 - Unless cords are properly grounded.
 - With damaged cord or plug.
 - With the use of additional extension cords. Only use manufacturer's extension cord equipped with machine which has proper capacity and is grounded.
 - If not in proper operating condition.
 - In outdoor areas.
 - In standing water.
 - Without bag and filter in place.
2. **Before operating machine:**
 - Make sure all safety devices are in place and operate properly.
3. **When using machine:**
 - Do not run machine over cords.
 - Do not pull machine by plug or cords.
 - Do not pull cords around sharp edges or corners.
 - Do not unplug by pulling on cords.
 - Do not stretch cords.

- Do not handle plug with wet hands.
- Keep cords away from heated surfaces.
- Do not pick up burning or smoking debris, such as cigarettes, matches or hot ashes.
- Report machine damage or faulty operation immediately.

4. Before leaving or servicing machine:

- Turn off machine.
- Unplug cords from wall outlet.

5. When servicing machine:

- Unplug cords from wall outlet.
- Use manufacturer supplied or approved replacement parts.

⚠ WARNING: Hazardous Voltage. Shock or electrocution can result. Unplug machine before servicing.

⚠ WARNING: Flammable materials or reactive metals can cause an explosion or fire. Do not pick up.

GROUNDING INSTRUCTIONS

Machine must be grounded. If it should malfunction or breakdown, grounding provides a path of least resistance for electrical current to reduce the risk of electrical shock. This machine is equipped with cords having an equipment-grounding conductor and grounding plug. The plug must be plugged into an appropriate outlet that is properly installed in accordance with all local codes and ordinances. Do not remove ground pin; if missing, replace plug before use.

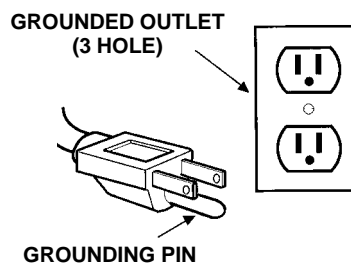

OPERATION

MACHINE COMPONENTS

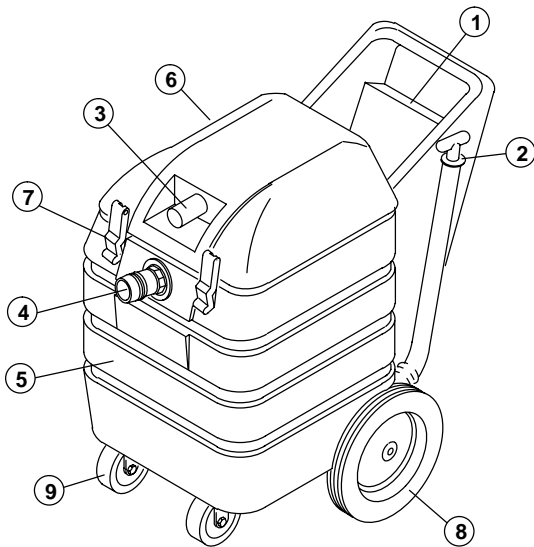

1. ON/OFF Switch
2. Drain Hose
3. Intake Hose Connector
4. Discharge Hose Connector
5. 76L (20 Gal) Recovery Tank
6. Recovery Tank Cover
7. Cover Latches
8. 254 mm (10 in) Stair Climbing Wheels
9. Swivel Casters
13. (50 ft) Extension Cord (not shown)

NOTE: See Parts List section for standard accessories.

SETUP AND OPERATION

FOR SAFETY: Do not operate machine unless operator manual is read and understood.

1. Carefully check carton for signs of damage. Report damages at once to carrier. Machine is fully assembled and ready for use.

2. Check that float shutoff screen and filter bag are installed in recovery tank (Figure 1).



FIG. 1

ATTENTION: Do not operate machine without screen and filter bag in place, vacuum motor and pump damage will result.

3. Connect 5 M (15 ft) hose to intake connector and 8 M (25 ft) hose to discharge connector (Figure 2). Place opposite end of discharge hose outside or to drain that will handle large volume of water.

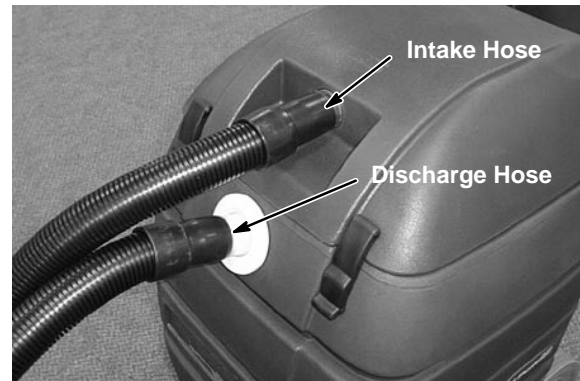

FIG. 2

NOTE: Do not exceed 31 M (100 ft) of intake hose. For best performance, length of 8 M (25 ft) is recommended. Discharge hose can be any horizontal length, do not raise discharge hose beyond 2 M (8 ft).

4. Attach accessory tool to intake hose if desired.
5. Connect equipped extension cords to pig tails on machine and plug each cord into a separate grounded circuit (Figure 3).

ATTENTION: Be certain to use a separate circuit for each power cord to prevent circuit overload (machine draws 17 amps).

FOR SAFETY: Do not operate machine with the use of additional extension cords. Only use manufacturer's extension cord equipped with machine which has proper capacity and is grounded.

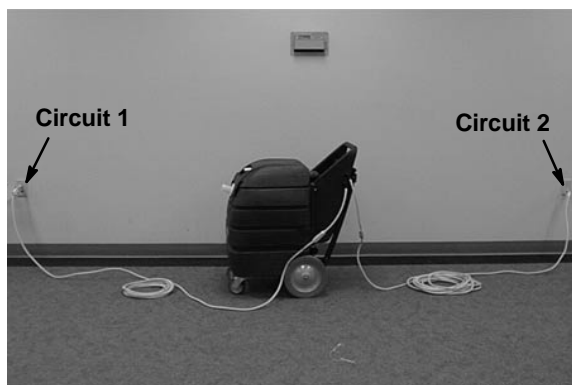

FIG. 3

4. Turn ON/OFF switch to the on position.
5. Begin vacuuming water. When water level reaches a certain height, the pump will automatically discharge water.

⚠ WARNING: Flammable materials or reactive metals can cause an explosion or fire. Do not pick up.

6. Observe recovery tank for excessive foam while operating. Foam will not activate float shut-off screen, located in recovery tank.

ATTENTION: Do not allow foam or water to enter float shut-off screen, vacuum motor damage will result.

7. After operating machine, turn machine off and drain excess water from recovery tank using drain hose.

MACHINE MAINTENANCE

To keep machine in good working condition, simply follow maintenance procedures below:

FOR SAFETY: When servicing machine, unplug cords from wall outlet.

1. Drain and flush recovery tank with clean water after each use (Figure 4).

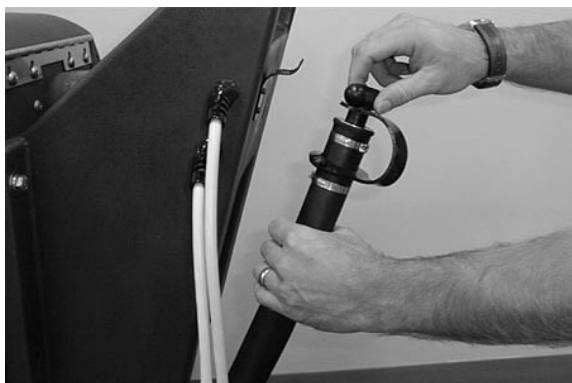

FIG. 4

2. Clean the float shut-off screen and filter bag located in recovery tank after each use (Figure 5).



FIG. 5

3. Inspect power cords for damage, replace immediately if damaged. Coil cords neatly after each use.
4. Inspect vacuum hoses for holes and loose cuffs.
5. Clean machine housing with an all purpose cleaner and damp cloth.
6. Inspect machine for leaks and loose hardware.
7. Lubricate wheels and casters with a water resistant oil.
8. Every 250 hours of use check vacuum motor for carbon brush wear. Replace brushes when worn to a length of 10mm (0.38 in) or less.

STORING MACHINE

1. Before storing machine, be certain to flush tank and drain machine of all water.
2. Store machine in a dry area in the upright position.
3. Open recovery tank cover to promote air circulation.

ATTENTION: Do not expose to rain. Store indoors.

ATTENTION: If storing machine in freezing temperatures, be sure that machine and pump are completely drained and dry.

RECOMMENDED STOCK ITEMS

Refer to Parts List section for recommended stock items. Stock Items are clearly identified with a bullet preceding the parts description. See example below:

Ref.	Part No.	Description	Qty.
1	701103	ASM., STANDPIPE	1
2	180613	● FLOAT, SHUTOFF	1
3	230187	NIPPLE	1
4	101714	● GASKET	1
5	210240	NUT, FLANGED	1

OPERATION

TROUBLESHOOTING

PROBLEM	CAUSE	SOLUTION
Poor pick up.	Float shut-off screen is clogged.	Clean screen inside recovery tank.
	Loose drain hose knob.	Close drain valve.
	Loose recovery tank cover.	Tighten down cover with latches.
	Damaged hose.	Replace hose.
Vacuum motor does not operate.	Unplugged cord.	Plug cords into separate grounded circuits.
	Faulty switch or loose wiring.	Contact Service Center.
	Tripped building circuit breaker.	Reset circuit breaker.
	Defective vacuum motor.	Contact Service Center.
Discharge pump does not operate.	Unplugged cord.	Plug cords into separate grounded circuits.
	Faulty pump float switch.	Contact Service Center.
	Tripped building circuit breaker.	Reset circuit breaker.
	Defective vacuum motor.	Contact Service Center.
Discharge pump operates continuously.	Airlock has formed in discharge pump inlet.	Connect open end of discharge hose to vacuum intake hose connector and turn on machine.
	Faulty pump float switch.	Contact Service Center.

SPECIFICATIONS

Model	Flood Pumper™ Plus
LENGTH	762 mm (30 in)
WIDTH	508 mm (20 in)
HEIGHT	889 mm (35 in)
WEIGHT	41 Kg (90 lbs)
RECOVERY TANK CAPACITY	60.5 L (16 gal)
VACUUM HOSE	4.5 m (15 ft) x 38 mm (1.5 in)
DISCHARGE HOSE	7.6 m (25 ft) x 38 mm (1.5 in)
FLOOR WAND WIDTH	330 mm (13 in)
DISCHARGE PUMP	120 volt, 100 psi/6.9 bar, 4.8 amp
DISCHARGE PUMP FLOW RATE	151 L (40 gal) per minute
VACUUM MOTOR	120 volt, 3-stage, 1.6 hp, 10.7 amp, 1242 watts
SEALED WATER LIFT	3048 mm (120 in)
POWER CORD LENGTH	15 m (50 ft)
TOTAL POWER CONSUMPTION	120V, 17 A, 2040 W (Use Separate Circuits)
DECIBEL RATING AT OPERATOR'S EAR, INDOORS ON CARPET	80dB(A)

ELECTRICAL DIAGRAM

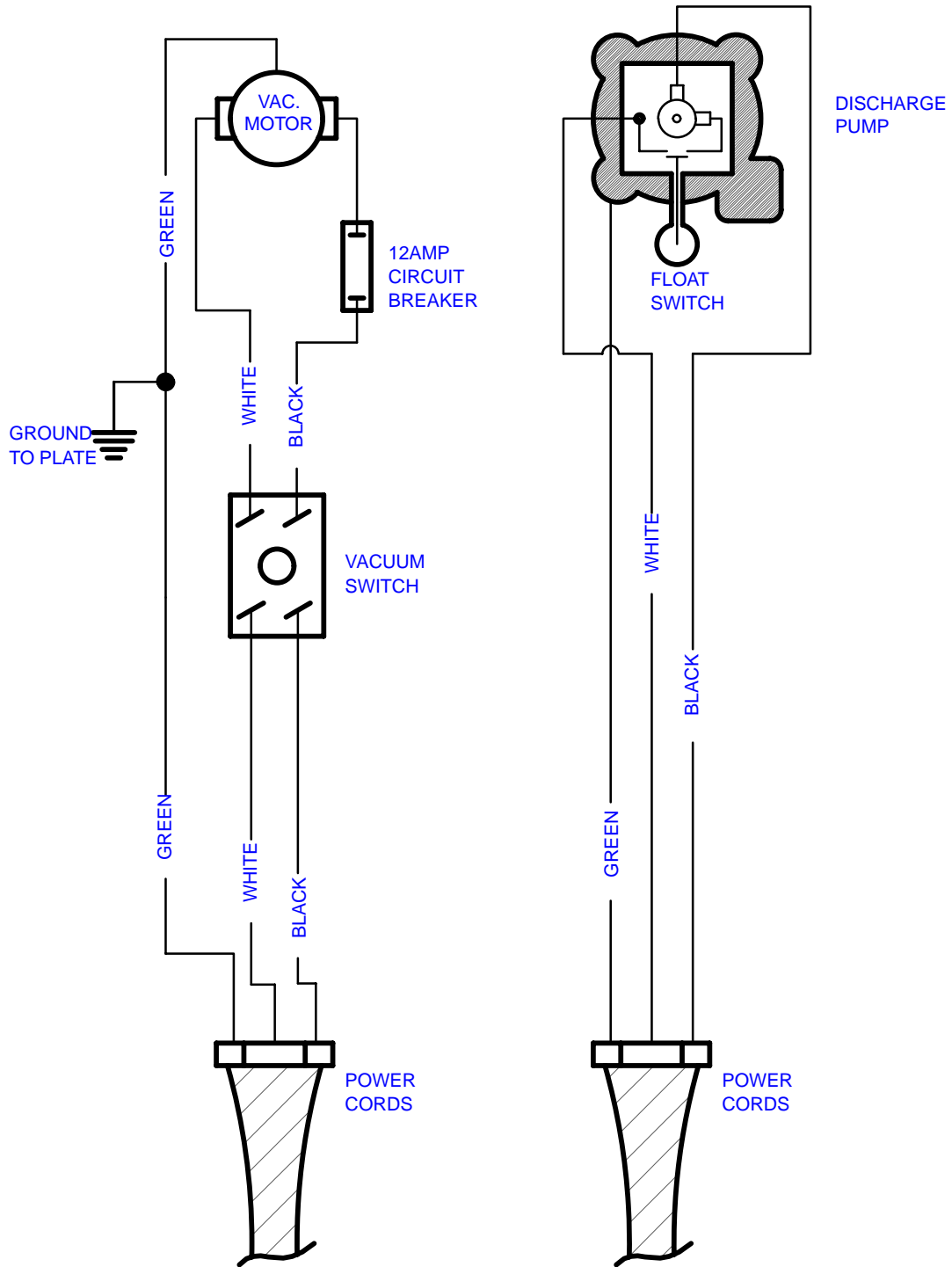

RECOVERY TANK GROUP

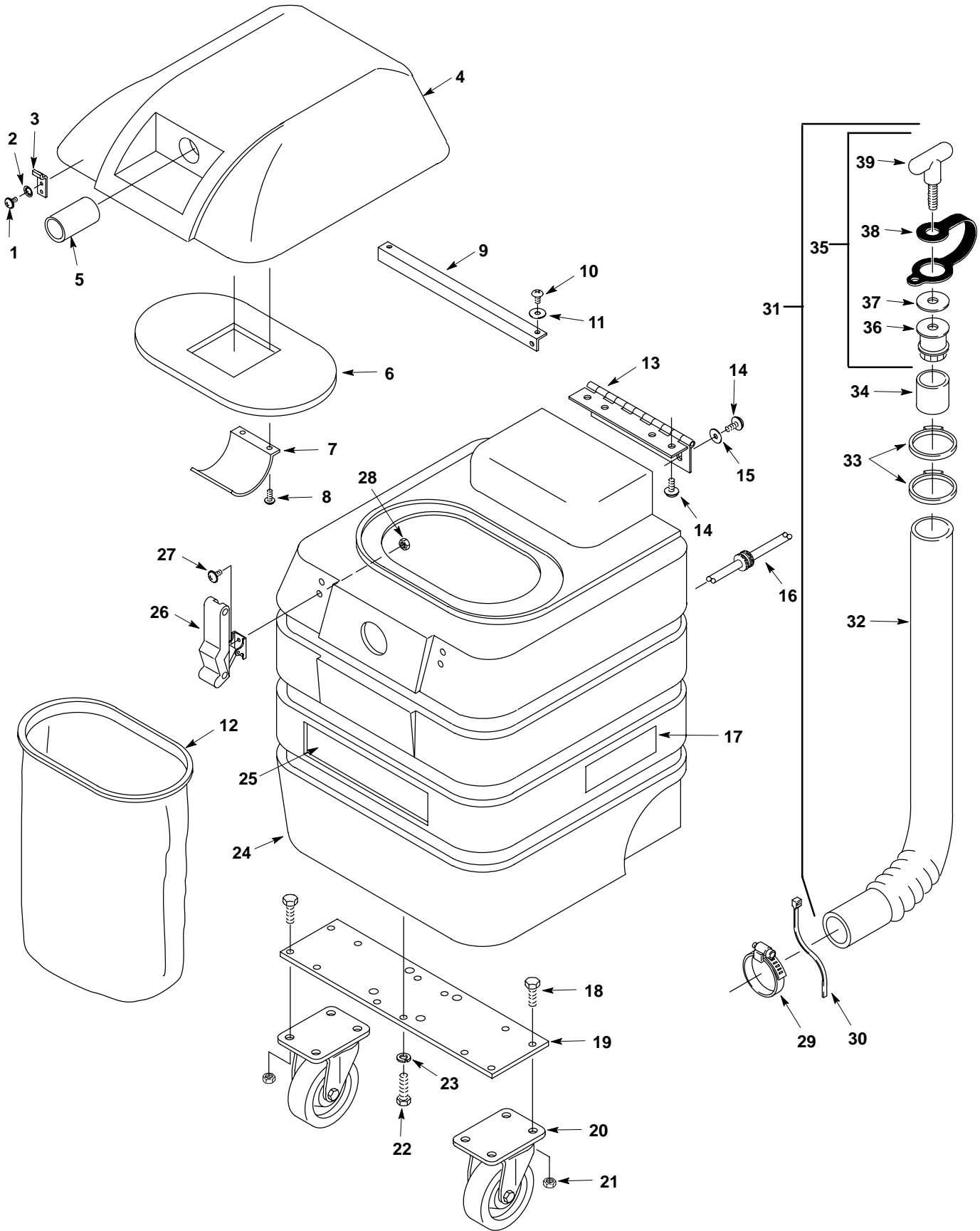

RECOVERY TANK GROUP

REF	PART #	DESCRIPTION	QTY.
1	140801	SCREW, 8-32X3/8	4
2	140023	WASHER. #8 INT	4
3	140932	LATCH, HOOD RUBBER W/ KEEPER	2
4	608613	COVER. 16G RM-SPGN	1
5	230905	TUBE, INLET	1
6	100097	●GASKET, 16 GALLON COVER	1
7	230497	BRACKET. AIR DEFLECTOR	1
8	140197	SCREW. 10-24X3/8	2
9	230482.BK	BRACKET. SUPPORT 16 GAL TANK	1
10	140824	SCREW. 1/4-20X5/8	2
11	140003	WASHER. 1/4X1	2
12	900222	●BAG, 16 GALLON	1
13	230318	HINGE. COVER 16 GALLON	1
14	140195	SCREW, 1/4-20X1/2	2
15	140000	WASHER, 1/4 FLT	1
16	130181	CORD, GRIP	1
17	608502	DECAL, FLOOD PUMPER PLUS	2
18	140223	SCREW, 5/16-18X3/4	8
19	231034	PLATE, CASTER MOUNT	1
20	103065	CASTER, SWIVEL 4"	2

REF	PART #	DESCRIPTION	QTY.
21	140546	NUT, 5/16-18 NYLK	2
22	140223	SCREW, 5/16-18X3/4	4
23	140015	WASHER, 5/16 SPLTLCK	4
24	608616	TANK, 16G RM-SPGN	1
25	608185	DECAL, NOBLES	1
26	140932	LATCH, HOOD RUBBER W/ KEEPER	2
27	140802	SCREW, 8-32X5/8	4
28	140288	NUT, NYLOCK M4 X 0.7	4
29	140307	CLAMP, HOSE	1
30	130041	WIRE TIE, NYLON	1
▽31	701058	●ASM., DRAINHOSE	1
▲32	160457	HOSE, DRAIN 25"	1
▲33	140072	CLAMP, 1-9/16	2
▲34	140921	SLEEVE, DRAIN HOSE	1
▲▽35	701061	●ASM., DRAINHOSE STOPPER	1
▲36	140955	PLUG, DRAIN HOSE W/RIBS	1
▲37	140056	WASHER, 3/8IDX1.500D	1
▲38	230882	STRAP, DRAIN STOPPER	1
▲39	230831	KNOB, DRAIN HOSE	1

▽ ASSEMBLY

▲ INCLUDED IN ASSEMBLY

● RECOMMENDED STOCK ITEMS

VACUUM MOTOR / MACHINE BASE GROUP

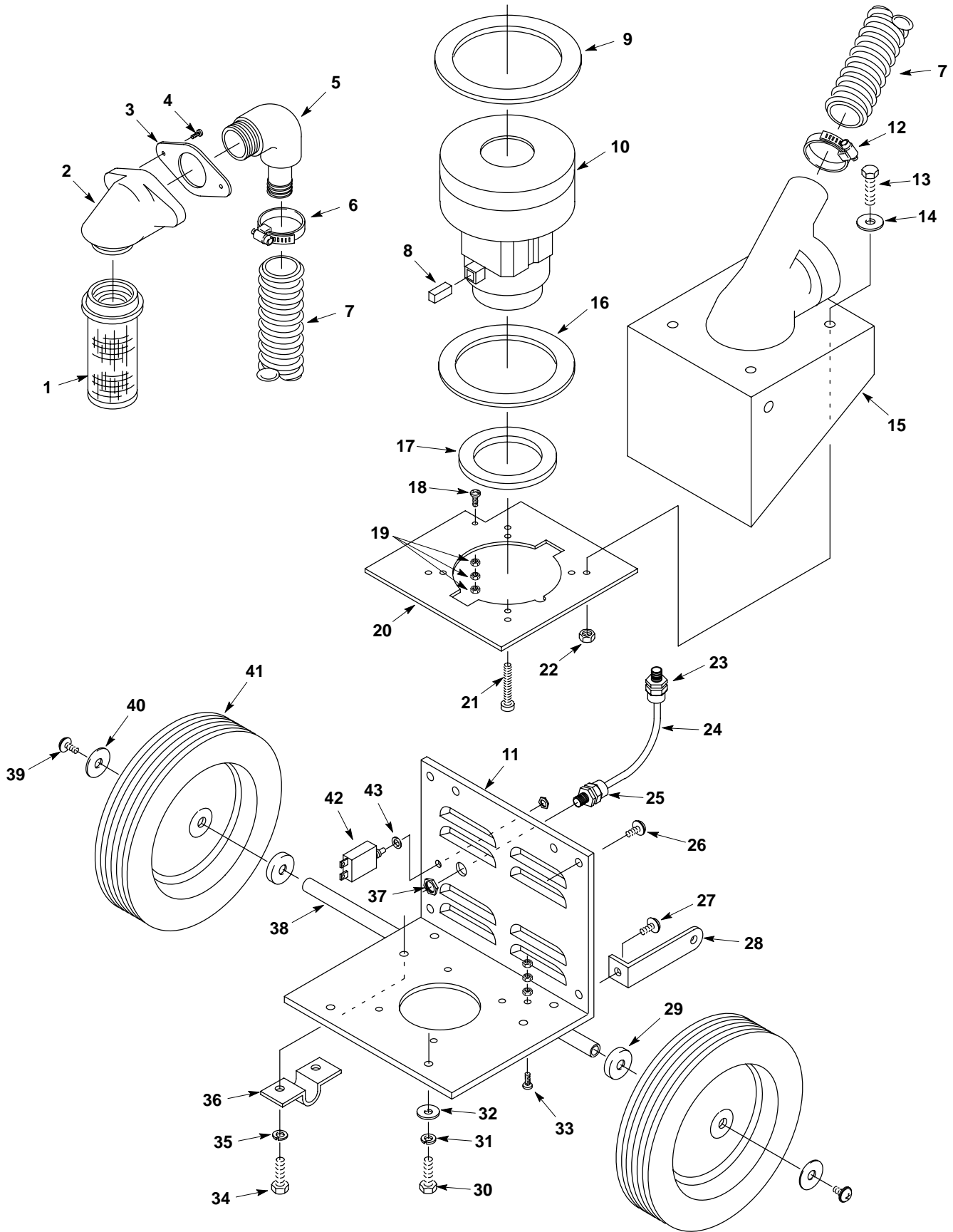

VACUUM MOTOR / MACHINE BASE GROUP

REF	PART #	DESCRIPTION	QTY.
1	180613	●FLOAT, SHUT-OFF	1
2	100381	ELBOW, VAC TUBE	1
3	100096	GASKET, VAC TUBE ELBOW	1
4	140824	SCREW, 1/4-20X5/8	2
5	700435	ASM., PVC ELBOW	1
6	140308	CLAMP, HOSE	1
7	160482	HOSE, VACUUM 2" X 13"	1
8	600272	●BRUSHES CARBON (2 PACK)	2
9	100038	●GASKET, VAC MOTOR	1
10	130417	●MOTOR, VAC 5.7 3 STG 120V	1
11	230486.BK	COVER PLATE	1
12	140308	CLAMP, HOSE	1
13	140199	SCREW, 1/4-20X4-1/2	4
14	140003	WASHER, 1/4X1	4
15	100380	HOUSING, VACUUM MOTOR	1
16	100143	●GASKET, VAC MOTOR 5.7	1
17	100095	●GASKET, VAC MOTOR END	1
18	140900	SCREW, 10-24X3/4	1
19	140519	NUT, 10-24 KEP	3
20	230522	PLATE, MOTOR MOUNT	1
21	140340	SCREW, #10-24X5/8	4
22	140501	NUT, 1/4-20 NYLK	4

● RECOMMENDED STOCK ITEMS

REF	PART #	DESCRIPTION	QTY.
23	130110	BUSHING, STRAIN-RELIEF	1
24	130267	CORD, 16/3X30" YELLOW	1
25	130181	CORD GRIP	1
26	140195	SCREW, 1/4-20X1/2	4
27	140824	SCREW, 1/4-20X5/8	2
28	230496.BK	SUPPORT, DRAIN HOSE	1
29	140063	●WASHER	1
30	140201	SCREW, 3/8-16X3/4	4
31	140017	WASHER, 3/8 SPLTLCK	4
32	140028	WASHER, 3/8 FLT	1
33	140900	SCREW, 10-24X3/4	1
34	140553	SCREW, 1/4-20X1/2	4
35	140016	WASHER, 1/4 LCK	4
36	230746	BRACKET, AXLE OFFSET	2
37	140504	NUT, CONDUIT LOCK 1/2"	1
38	230317	AXLE	1
39	140195	●SCREW, 1/4-20X1/2	2
40	140003	●WASHER, 1/4X1	2
41	103068	●WHEEL, 10"X1.75 GRAY	2
42	130670	●BREAKER CIRCUIT 12A	1
43	140022	WASHER, 3/8 INT	1

DISCHARGE PUMP GROUP

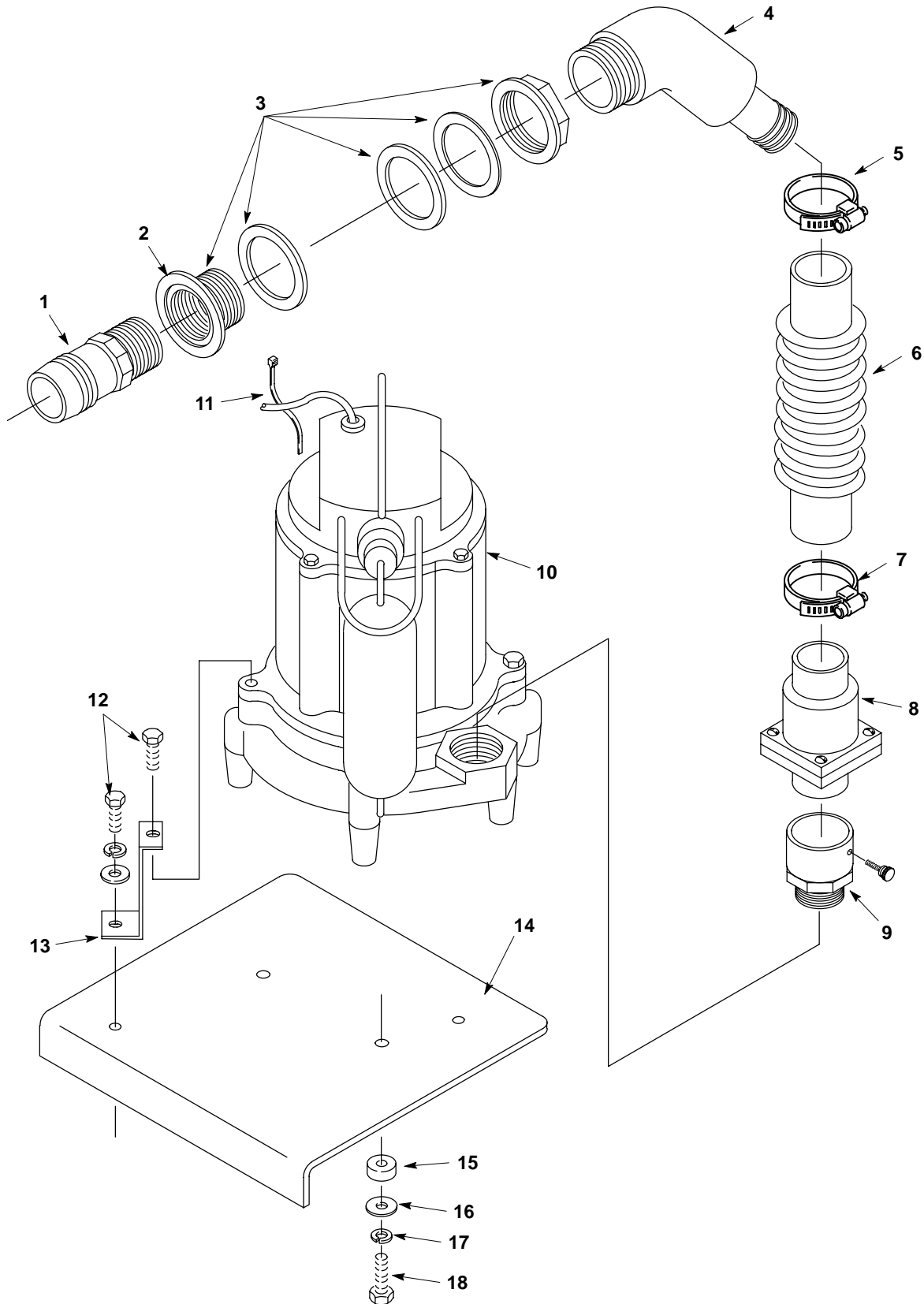

DISCHARGE PUMP GROUP

REF	PART #	DESCRIPTION	QTY.
1	150500	FITTING, 1-1/2MX1-1/2H	1
2	608517	DECAL, DISCHARGE	1
3	150301	FITTING, INLET	1
4	608467	ASM., 45 DEGREE ELBOW	1
5	140308	●CLAMP, HOSE	1
6	608488	●HOSE, 1.62 ID 6"	1
7	140308	●CLAMP, HOSE	1
8	210007	●VALVE, CHECK	1
9	230183	FITTING, 1-1/2	1

REF	PART #	DESCRIPTION	QTY.
10	608885	●PUMP, DISCHARGE	1
11	130041	●WIRE TIE, NYLON	1
12	140553	SCREW, 1/4-20X1/2	2
13	608884	BRACKET, PUMP	2
14	608883	PLATE, PUMP BLACK	1
15	100029	●GASKET, TANK CONNECTOR	2
16	140027	WASHER, 5/16 FLT	2
17	140015	WASHER, 5/16 SPLTLCK	2
18	140223	SCREW, 5/16-18X3/4	2

● RECOMMENDED STOCK ITEMS

HANDLE GROUP

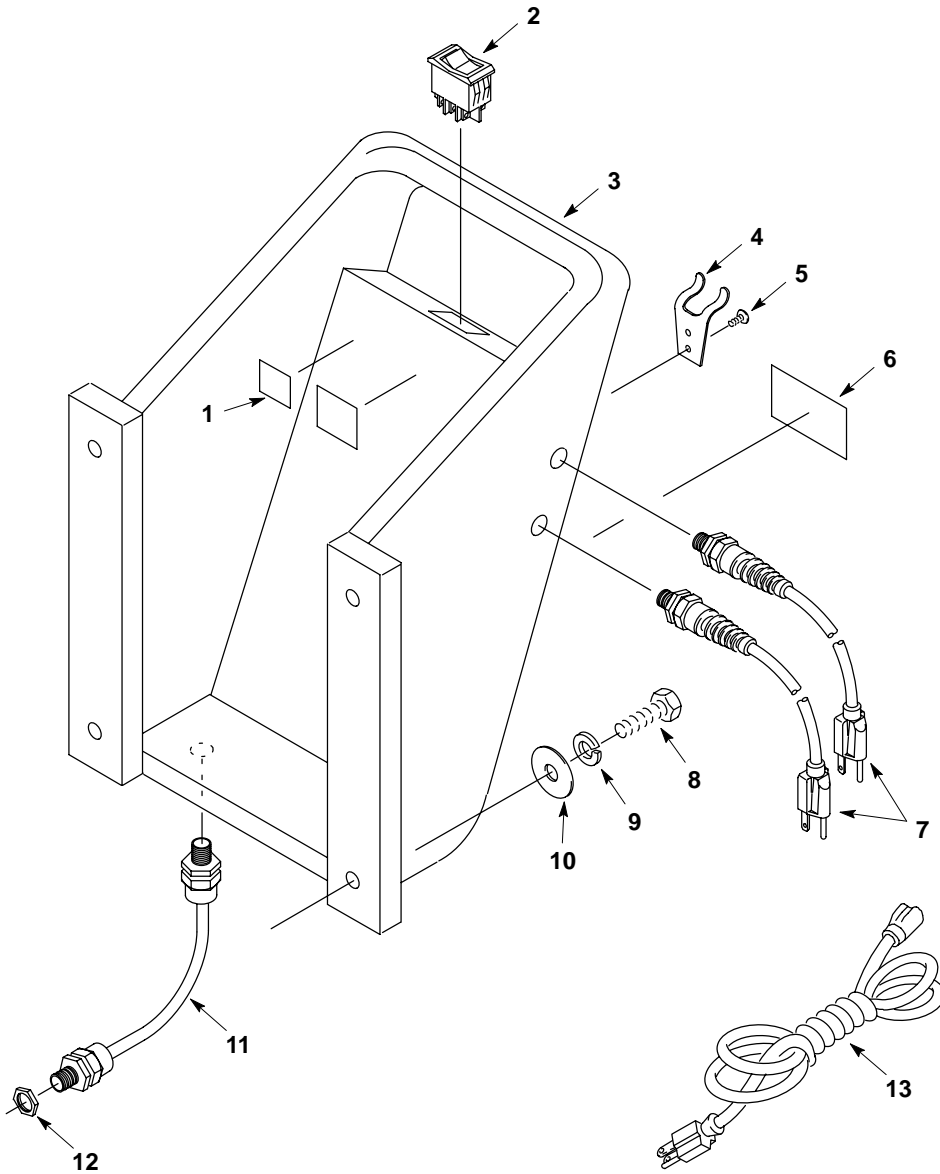

REF	PART #	DESCRIPTION	QTY.
1	578729	DECAL, "READ MANUAL"	1
2	19417	●SWITCH, W/ ON/OFF	1
3	608618	HANDLE, 12/16 RM-SPGN	1
4	230696.BK	●BRACKET, DRAIN HOSE	1
5	140825	SCREW, #6X1/2	2
6	602596	DECAL, WARNING WET/DRY VAC	1
7	130201	●CORD, 16/3X28" YELLOW	2

REF	PART #	DESCRIPTION	QTY.
8	140231	SCREW, 3/8X1-1/2	4
9	140017	WASHER, 3/8 SPLTLCK	4
10	140028	WASHER, 3/8 FLT	4
11	130267	CORD, 16/3X30" YELLOW	1
12	140504	NUT, CONDUIT LOCK 1/2"	1
13	130250	●CORD, 16/3X50' EXT SJT YELLOW	2

● RECOMMENDED STOCK ITEMS

FLOOR TOOL, HOSES AND SQUEEGEE GROUP

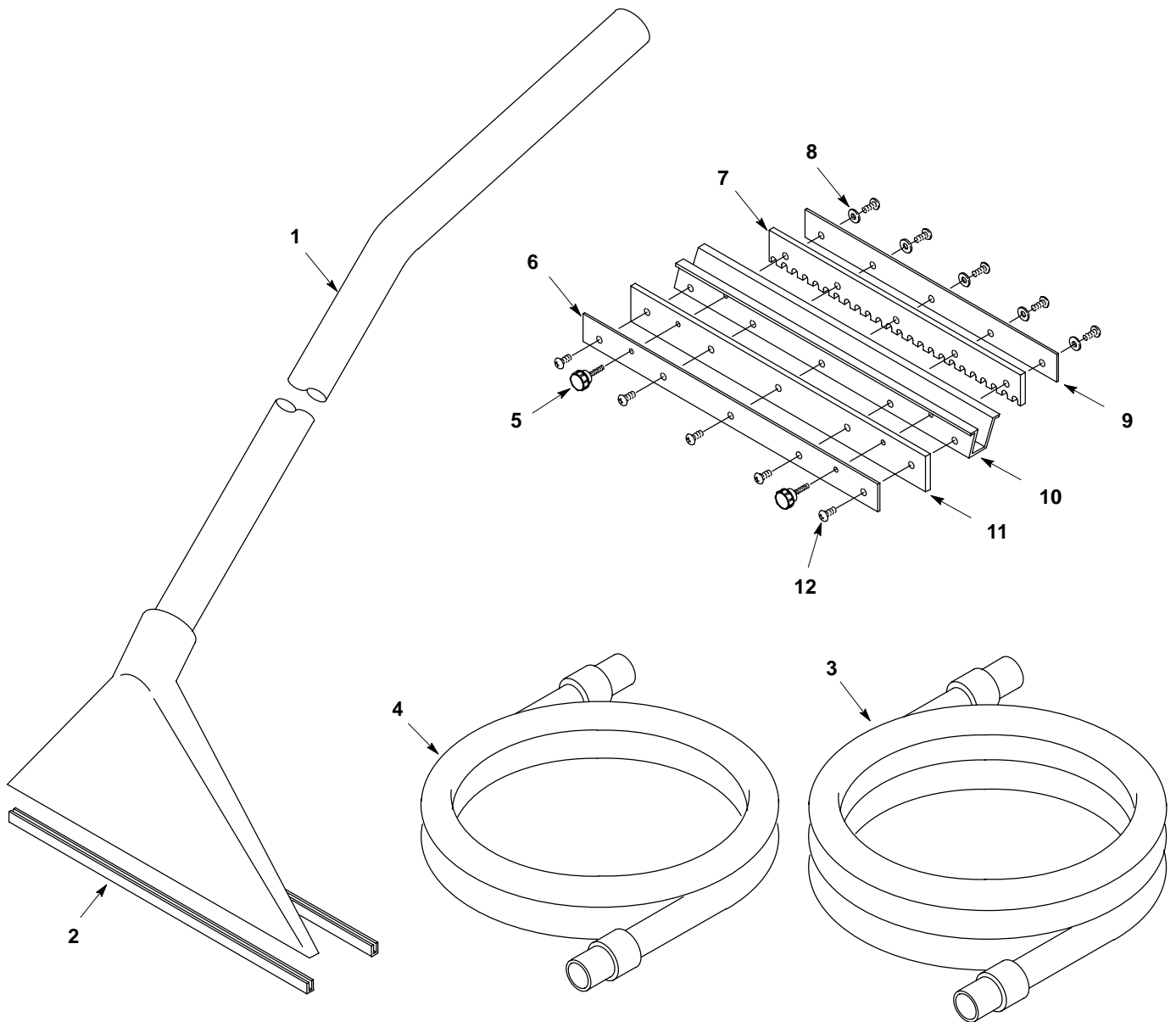

REF	PART #	DESCRIPTION	QTY.
▽	200125	TOOL, FLOOR (COMPLETE)	1
▲1	200426.BK	TOOL, FLOOR	1
▲2	200939	SHOE, 13" FLOOR TOOL	2
▽	600341	KIT, HOSE/SQUEEGEE	1
▲3	160466	●HOSE, VAC 1.5X25	1
▲4	160465	●HOSE, VAC 1.5X15'	1
▲▽	200170	SQUEEGEE ASSEMBLY	1
▲5	240200	KNOB, SQUEEGEE	2

REF	PART #	DESCRIPTION	QTY.
▲6	240054.BK	PLATE, NUT 15" SQUEEGEE	1
▲7	240060	BACKING BLADE, 15" SQUEEGEE	1
▲8	140011	WASHER, 3/16 FLT	5
▲9	240055.BK	PLATE, NUT 13" SQUEEGEE	1
▲10	240056.BK	CHANNEL, 15" SQUEEGEE	1
▲11	240059	WIPING BLADE, 15" SQUEEGEE	1
▲12	140887	SCREW, 10-24X3/8	10

▽ ASSEMBLY

▲ INCLUDED IN ASSEMBLY

● RECOMMENDED STOCK ITEMS