

BACK PACK VACUUM

INTRODUCTION

OPERATING & MAINTENANCE INSTRUCTIONS

READ THIS BOOK

This operator's book has important information for the use and safe operation of this machine. Read this book carefully before starting the machine. Keep this book and tell all operators to read the book. If you do not follow the instructions, you can cause an injury or damage equipment, furniture or buildings.

For new books write to:

Pacific Steamex, Inc.
2259 S. Sheridan
Muskegon, MI 49442-6252

Carefully inspect all components to ensure that there is no concealed freight damage. If such damage is discovered, file a "CONCEALED DAMAGE REPORT" immediately with the delivering carrier.

The contents of this manual are based on the latest product information available at the time of publication. Pacific Steamex reserves the right to make changes or improvements to its machines without notice.

**FOR YOUR CONVENIENCE, RECORD THE
MACHINE MODEL AND SERIAL NUMBER
HERE:**

MODEL _____

SERIAL NUMBER _____

IMPORTANT SAFETY INSTRUCTIONS

READ AND UNDERSTAND ALL WARNINGS AND INSTRUCTIONS IN THIS BOOK BEFORE USING THIS MACHINE! If you do not understand, ask your supervisor.

WARNING: To reduce the risk of fire, electric shock, or injury:

1. DO NOT USE THIS VACUUM FOR PICK UP OF WET DEBRIS.
2. You must be trained to operate this machine. This machine is to be operated for its intended use only.
3. Do not operate this machine unless it is completely assembled.
4. Keep the machine surface dry. Do not subject to rain. Store the machine in a dry building area. Clean the machine with a dry cloth only.
5. Machines can cause an explosion when near flammable materials and vapors. Do not use or store this machine with or near fuels, grain dust, solvents, thinners, or other flammable materials. Do not use flammables to clean this machine.
6. Maintenance and repairs must be done by a qualified or authorized person.
7. If the machine is not working as it should, has been dropped, damaged, left outdoors, or dropped into water, return it to a service center.
8. Always use a three-wire electrical system connected to the electrical ground. For maximum protection against electrical shock, use a circuit that is protected by a ground fault circuit interrupter. Consult your electrical contractor.
9. To prevent electric shock, always remove the electrical plug from the electrical outlet before doing any repairs or maintenance and when leaving the machine unattended.
10. Do not pull cord, use cord as a handle, close a door on cord, or pull cord around sharp edges or corners. Keep cord away from heated surfaces. Do not use with damaged cord or plug.
11. Keep the electrical parts of the machine dry.
12. Make sure all labels, decals, warnings, cautions and instructions are fastened to the machine.

Grounding Instructions

This machine must be grounded. If it should malfunction or break down, grounding provides a path of least resistance for electric current to reduce the risk of electric shock. This machine is equipped with a cord having an equipment-grounding conductor and grounding plug. The plug must be inserted into an appropriate outlet that is properly installed and grounded in accordance with all local codes and ordinances.

WARNING - Improper connection of the equipment-grounding conductor can result in a risk of electric shock. Check with a qualified electrician or service person if you are in doubt as to whether the outlet is properly grounded. Do not modify the plug provided with the machine - if it will not fit the outlet, have a proper outlet installed by a qualified electrician.

This machine is for use on a nominal 120-volt circuit, and has a grounded plug that looks like the plug illustrated in figure A. A temporary adapter that looks like the adapter illustrated in figures B and C may be used to connect this plug to a 2-pole receptacle as shown in figure B if a properly grounded outlet is not available. The temporary adapter should be used only until a properly grounded outlet (figure A) can be installed by a qualified electrician. The green colored rigid ear, lug, or the like extending from the adapter must be connected to a permanent ground such as a properly grounded outlet box cover. Whenever the adapter is used, it must be held in place by a metal screw.

NOTE: In Canada, the use of a temporary adapter is not permitted by the Canadian Electrical Code

EXTENSION CORDS

Use only three-wire 14/3 or larger gauge approved extension cords that have three-prong grounding type plugs and three-pole receptacles that accept the appliance's plug. Replace or repair any damaged cords or plugs.

When servicing, refer to authorized person only. Use only identical replacement parts.

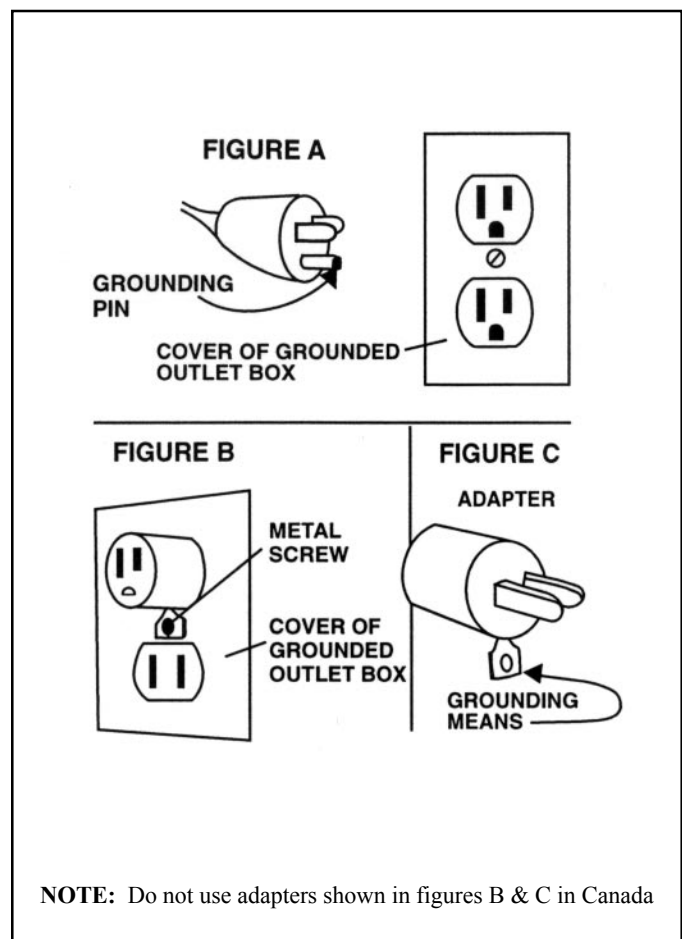

OPERATING PROCEDURES

WARNING! For the safe operation of this machine follow the instructions given in this booklet and the training given by your supervisor. Failure to do so can result in personal injury and/or damage to machine and property!

DO NOT OPERATE MACHINE IN AN EXPLOSIVE ENVIRONMENT!

WARNING! NEVER USE THIS MACHINE TO PICK UP VOLATILE OR EXPLOSIVE MATERIALS.

WARNING! DO NOT PICK UP WET MATERIAL WITH THIS MACHINE.

The model shown in this manual is intended for commercial use and for vacuuming dry material only.

PREPARATION

To prepare the machine for operation, make sure it is properly assembled. If in doubt, ask your supervisor.

- **Properly install the filter bag in the vacuum:** Push the filter bag inlet over the vacuum inlet elbow (item 8-receptacle) which is located on the bottom of the top cover. Replace the filter bag when full.

OPERATION

1. **Plug the machine's power cable into a properly grounded outlet** (see Safety Instructions).
2. **Connect the vacuum hose** to the inlet port at the top of the machine. Note: The top cover can be rotated for left or right hand hose attachment.
3. **Place the Back Pack Vacuum on your back** by putting your arms through the straps. Adjust the straps to a comfortable working position. Then connect and adjust the waistband.
4. **Attach the tool** of your choice to the working end of the vacuum hose. The tools included with the Back Pack Vacuum are the upholstery, dusting and crevice tools.
5. **Turn ON the switch** (item 27) and begin your DRY pick up maintenance application.

MAINTENANCE

ALWAYS turn the machine power switch **OFF** and **UNPLUG** the power cord from the electrical outlet before doing any clean up or repairs, and when the machine is left unattended.

AFTEREACHUSE:

- **Inspect the filter bag.** If the bag is full or damaged install a new one.

Filter Bag, 10 Pack – Part Number 620601
Cloth Bag (optional) – Part Number 620602

- **Check the cord and plug** for nicks, cuts or damage. Report these to your supervisor for correction. Also wrap the electrical cord and hang it on the strap provided (item 16).
- **Store the machine in a clean dry area.**

WEEKLY:

- **Inspect and clean the secondary filter assembly**, item 10, part number 633301. This filter is constructed of foam over a plastic mounting ring. It is installed over the vacuum blower chamber located in the main housing. To remove the filter: slide it up and off the vacuum blower housing. To clean the filter: Do NOT wet the filter or blow the debris out with compressed air. Tap the filter lightly to remove the excess debris. Replace the filter if there are any rips or tears.

WARNING

- DRY PICKUP ONLY
- DO NOT USE NEAR FLAMMABLE FLUIDS OR COMBUSTIBLE MATERIALS.
- DO NOT USE OUTDOORS IN RAIN OR SNOW. STORE INDOORS.

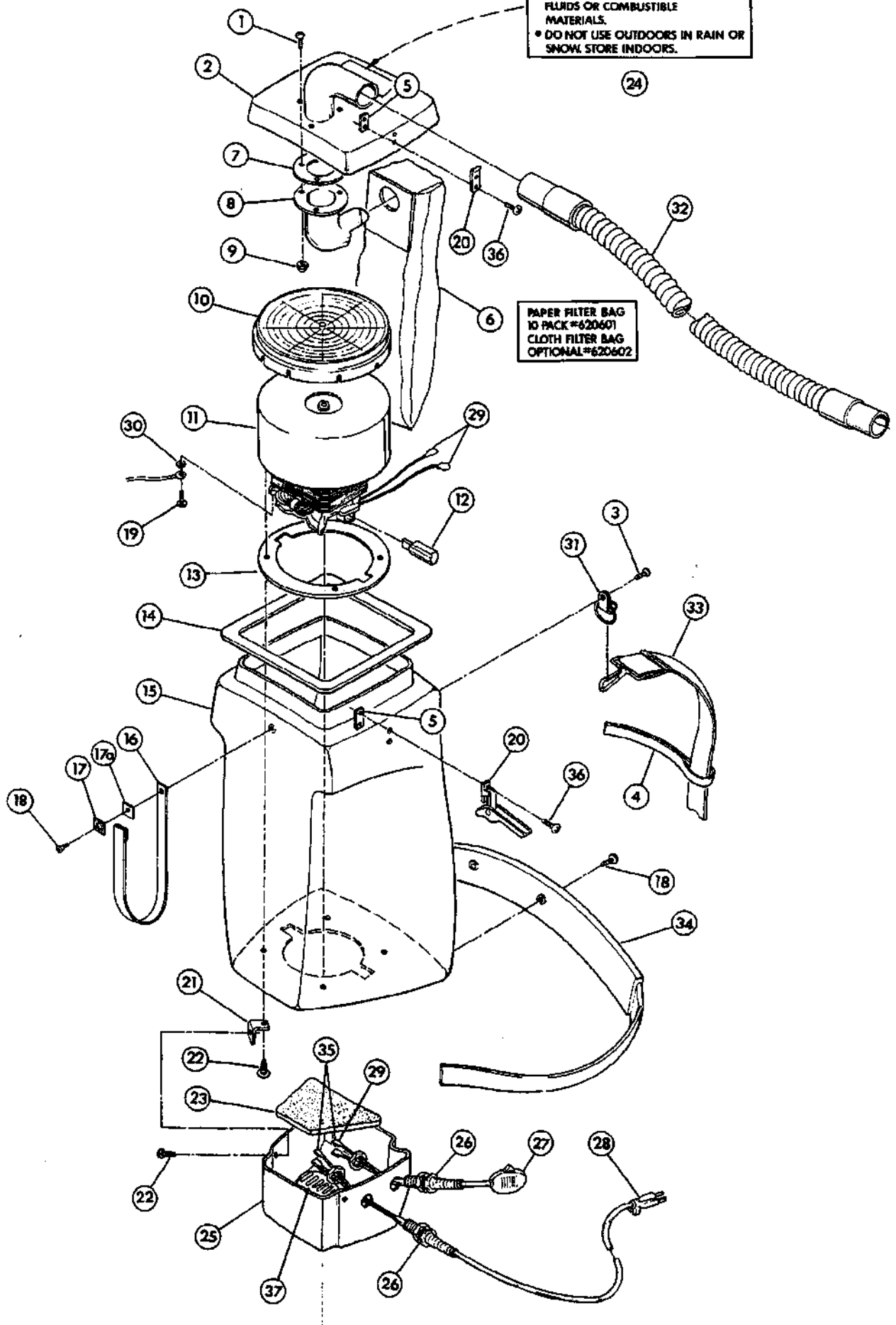

PAPER FILTER BAG
 10 PACK #620601
 CLOTH FILTER BAG
 OPTIONAL #620602

Back Pack Vacuum Parts List

ITEM	PART NO.	DESCRIPTION	QTY.
1	W324D	Screw 6-32x1/2 RHP	3
2	632303	Cover, Dark Gray	1
3	962015	Screw 10-32x3/8 PH	4
4	638504	Cross Strap R.H.	1
	638505	Cross Strap L.H.	1
5	636601	Plate-Nut	4
6	620601	Filter Bag (Sold in 10pk)	0.1
	620602	Filter Bag Cloth (Optional)	
7	633401	Gasket-Bag Mount	1
8	637502	Receptacle-Bag	1
9	W144D	Nut 6-32 Hex w/Nyloc	3
10	633301	Filter-Final	1
11	635201	Motor-Vac 115V	1
12	630901	Brush-Carbon	2
13	633403	Gasket-Motor Mount	1
14	633402	Gasket	1
15	634202	Housing-Main	1
16	228503	Strap	1
17	639402	Velcro	1
17a	638506	Support-Velcro	1
18	W310D	Screw 10-32x3/8 FHP	3

ITEM	PART NO.	DESCRIPTION	QTY.
19	962030	Screw 10-32x1/2 PH	1
20	222001	Clamp	2
21	630801	Bracket-Vac Mounting	4
22	962089	Screw 10-32x3/4PHP	8
23	638503	Sound Deadener	1
24	615102	Lable-Warning	1
25	632304	Cover-Motor	1
26	632401	Strain Relief	2
27	908064	Switch	1
	908064A	Cord Asm w/Switch	
28	908065	Cord Assembly	1
29	S936P	Terminal-Male	3
30	W124D	Washer, Lock #10Tooth	1
31	632001	Clamp-Ring for Strap	4
32	634101	Hose Assembly	1
33	638501	Strap Assembly	2
34	631301	Belt, Shoulder Strap	1
35	S948P	Terminal-Female	3
36	W515D	Screw 8-32x1/2 PHP	8
37	633601	Guard-Vac Exhaust	1

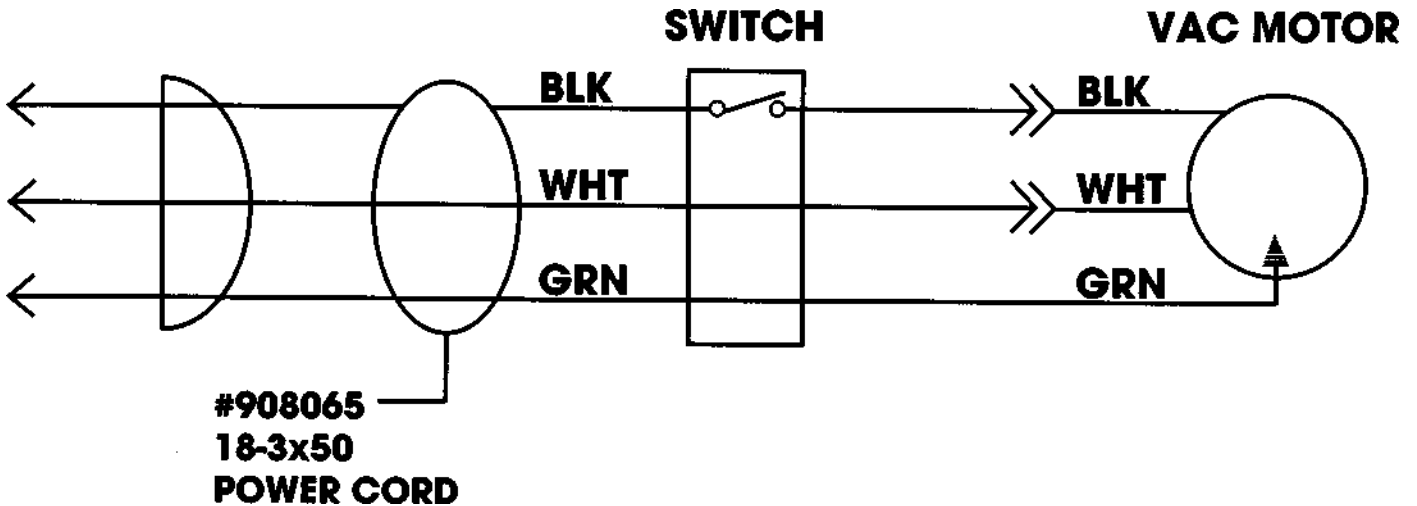

WARRANTY POLICY

PACIFIC STEAMEX INC. LIMITED WARRANTY

The **Pacific Steamex** Inc. Back Pack Vacuum has been manufactured, tested and inspected in accordance with specific engineering requirements and is WARRANTED to be free from defects in workmanship and materials as follows:

- Five (5) years – Rotational molded components.
- Two (2) years – Vacuum Motor
- One (1) year – All other components unless excluded below.

This warranty extends to the original user/purchaser and only when used, operated and maintained in accordance with **Pacific Steamex** Inc. Operating and Maintenance instructions.

This warranty does not apply to the following wear parts and accessories of the machine including:

<u>Part Number</u>	<u>Part Name</u>
620601	Paper Bag Filters
620602	Cloth Filter Bags
633301	Filter
630901	Carbon Brush
908065	Cord Assembly
634101	Hose Assembly

Nor does it apply to damage or failure caused by improper use, abuse or neglect. Warranty credit or replacement of return parts including motors, pumps, etc., is subject to incoming inspection of those items.

To secure repair under this warranty, the following procedure should be taken:

- The inoperative machine or warranted parts must be delivered to the authorized dealer with shipping and delivery charges prepaid. If unable to locate the Dealer, you may contact **Pacific Steamex** Inc. at the address listed herein for the location of the nearest **Pacific Steamex** Inc. repair center or agent or for other instructions pertaining to your warranty difficulty.
- Upon compliance with the above warranty procedure, all warranted repairs would be completed at no additional charge or cost to the user.
- Only **Pacific Steamex** Inc. or its authorized dealers and agents may make no charge warranty repairs on this product. All others do so at their own risk.

This warranty limits **Pacific Steamex** Inc. liability to the repair of the product and/or warranted parts replacement and does not include incidental or consequential damages arising from the use of a **Pacific Steamex** Inc. machine whether defective or not.

This warranty is in lieu of all other expressed or implied warranties and is extended to the original purchaser/user.

PACIFIC STEAMEX, INC.
2259 S. SHERIDAN
MUSKEGON, MICHIGAN 49442-6252
616-773-1330
FAX 1-616-773-1642