

Pre-Sweep 340 Gas

Model: 340699

OPERATION

SERVICE

PARTS

CARE

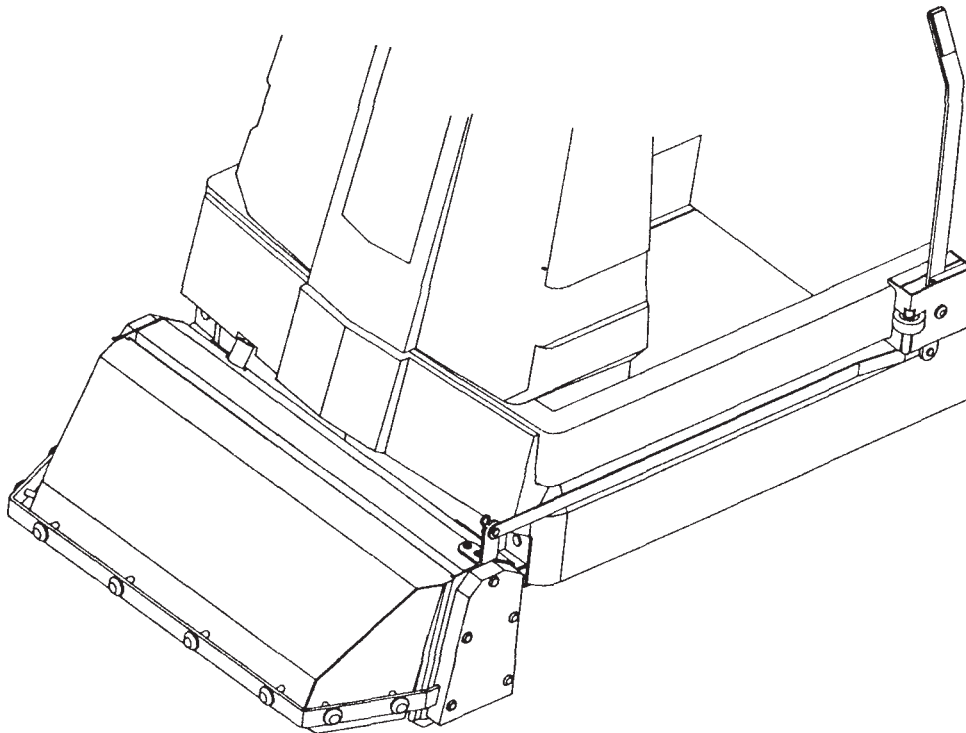

Revised

Minuteman[®]

TABLE OF CONTENTS

	Page
Safety Instructions	1
Installation Instructions	2, 3, 4
Wiring Diagram	5
Hydrostat Drive System	6
Repair/Replacement Parts	8

IMPORTANT SAFETY INSTRUCTIONS

CAUTION

Operators must read and understand this manual before operating or maintaining this equipment.

- Keep hands and feet clear of moving parts while machine is in operation.
- Electrical motors and components can cause an explosion when operated near explosive materials or vapors. Do not operate this machine near flammable materials such as solvent, thinners, fuels, grain dusts, etc.
- Make sure all switches are turned "OFF" and battery connections are removed before performing any maintenance procedures.
- Store or park this machine on a level surface only.

DANGER

Gasoline is highly flammable and its vapors are explosive. To prevent personal injury or property damage:

- Do not add fuel if engine is running or still hot from recent operation. Allow engine to cool for at least three minutes.
- Do not fill fuel tank indoors. After filling, wipe up any spills and move away from gasoline fumes before starting engine.
- Do not allow open flame, matches, or smoking in area.
- Fill Fuel Tank with fresh, clean unleaded regular automotive gasoline, (leaded regular and unleaded or leaded premium grades of gasoline are acceptable substitutes).
- Do not mix oil with gasoline.
- Clean the area around the fuel fill cap and remove the cap from the fuel tank. Insert a clean funnel into the fuel tank.
- Fill the tank to 1/2 inch below the bottom of the filter neck to provide space for any fuel expansion.
- Reinstall the fuel fill cap securely and wipe up any spilled gasoline.

BEFORE STARTING

- 1) PARK MACHINE ON LEVEL SURFACE AND SET PARKING BRAKE.
- 2) KEY SWITCH MUST BE IN THE "OFF" POSITION.

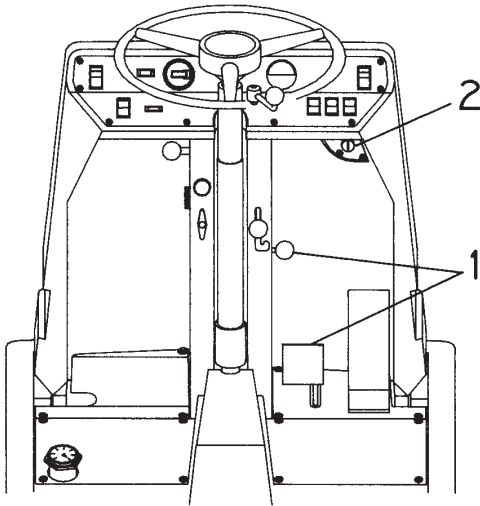

STEP 1

POWER DISCONNECT

- 1) DISCONNECT DC POWER BEFORE PERFORMING ANY MODIFICATION TO THE MACHINE. UNSCREW WING NUT ON POSITIVE (+) LEAD FROM BATTERY AND DISCONNECT WIRE.

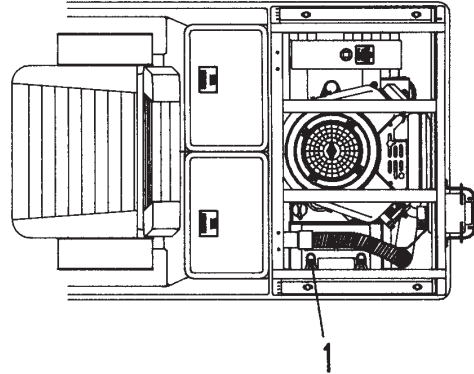

STEP 2

SPOOL VALVE INSTALLATION

- 1) IMPORTANT: USE HYDRAULIC SCHEMATIC AS A GUIDE TO ASSEMBLE SPOOL VALVE HOSES PROVIDED IN KIT.
- 2) UNSCREW RIGHT REAR FLOORBOARD AND REMOVE FOR EASIER ACCESS.
- 3) USING A 23mm WRENCH, DISCONNECT HOSE (NO. 18 ON DIAGRAM) FROM SWIVEL FITTING COMING OUT OF DRIVE VALVE.
- 4) INSTALL SPOOL ASSY (CONSISTING OF NOS. 69, 70, 71, 72, 73, 79, 84, AND 81). TIGHTEN ITEM 69 INTO DISCONNECTED SWIVEL FITTING OFF OF DRIVE VALVE USING A 23mm WRENCH.
- 5) INSTALL TEE ASSY (CONSISTING OF NOS. 74, 76, 77) ON TO DISCONNECTED HOSE (NO. 18).
- 6) TIGHTEN THESE TWO ASSY TOGETHER SO THAT ITEM 77 IS PARALLEL WITH SPOOL VALVE (ITEM 72).
- 7) INSTALL HOSE ASSY. (CONSISTING OF NOS. 78, 84, AND 82) ONTO ITEM 77. HOSE NO. 78 IS TO RUN PARALLEL WITH HOSE NO. 79.
- 8) MAKE SURE ALL NEW CONNECTIONS ARE TIGHT AS TO PREVENT LEAKS IN THE HYDRAULIC SYSTEM.
- 9) ROUTE HOSES TOWARDS LEFT FRONT CORNER OF THE MACHINE. MAKE SURE THAT HOSES DO NOT INTERFERE WITH THE RASING AND LOWER OF SIDE SQUEEGER AND THE BRUSHES.
- 10) REINSTALL RIGHT REAR FLOOR BOARD

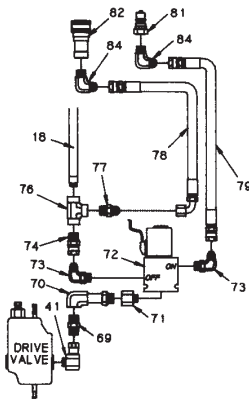

STEP 3

RELIEF LINE INSTALLATION

- 1) REMOVE LOWER FRONT ACCESS PANEL AND STORE AWAY.
- 2) LOCATE GREY HOSE THAT COMES FROM BRUSH VALVE AND GOES TO MULTIPLE COUPLED FITTINGS. (SEE ITEM 15 ON HYDRAULIC SCHEMATIC).
- 3) USING SHARP KNIFE, CUT HOSE 8" IN FROM COUPLED FITTINGS. THEN MAKE ANOTHER CUT 4" IN FROM FITTINGS. DISCARD 4" SECTION THAT WAS JUST REMOVED.
- 4) SLIDE PROVIDED HOSE CLAMP ON EACH CUT END OF THE GRAY HOSE.
- 5) PRESS GRAY HOSE ONTO EACH END EACH END OF TEEED HOSE ASSY. NOTE: 90° HOSE BARB IS TO FACE UP TOWARDS BRUSH VALVE. TIGHTEN TWO HOLE CLAMPS FIRMLY.

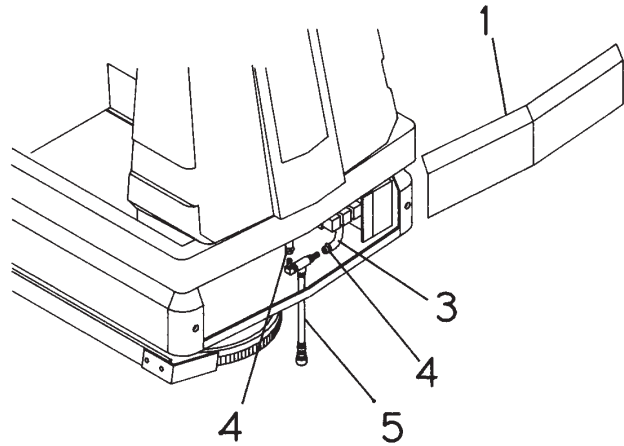

STEP 4

WIRE HARNESS CONNECTIONS

- 1) REMOVE FRONT ELECTRICAL BOX COVER AND SET ASIDE.
- 2) CUT OUT PRESWEEP SWITCH HOLE IN DASHBOARD WITH A SHARP KNIFE.
- 3) REMOVE SOLUTION CONTROL LEVER AND DASHBOARD.
- 4) INSTALL SWITCH COVER OVER SWITCH. PRESS SWITCH INTO CUT-OUT HOLE UNTIL FLUSH WITH DASHBOARD.
- 5) CONNECT YELLOW WIRES AS FOLLOWS. SEE WIRE SCHEMATIC FOR REFERENCE.
 - A) CONNECT 10" WIRE (741023) FROM NEW SWITCH TO ING. ON BACK OF KEY SWITCH.
 - B) CONNECT 24" WIRE (741021) FROM OTHER SIDE OF SWITCH TO DASH WIRING HARNESS.
 - C) CONNECT 36" WIRE (741022) FROM LOWER WIRING HARNESS TO WIRE OFF OF SPOOL VALVE.
 - D) CONNECT REMAINING WIRE FROM SPOOL VALVE TO BOLT ON HORN FOR GROUND.
- 6) PLUG THE MAIN WIRE HARNESSES BACK TOGETHER.
- 7) REINSTALL DASHBOARD, SOLUTION CONTROL LEVER, AND ELECTRICAL COVER.

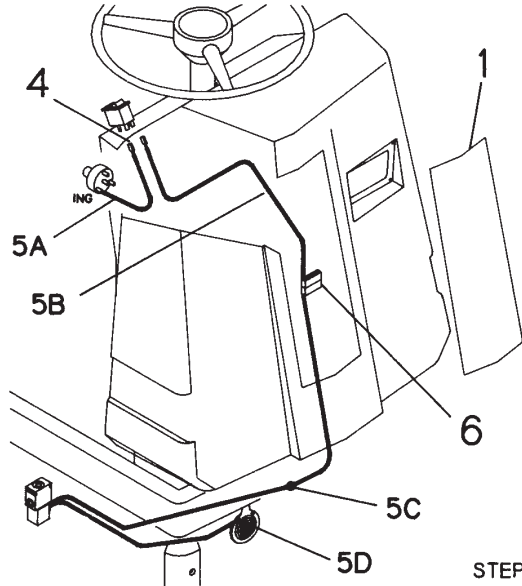

STEP 5

PRESWEEP INSTALLATION

- 1) INSTALL LEFT AND RIGHT MACHINE BRACKETS USING FASTENERS PROVIDED.

710986	3/8-16 x 1" TRUSS HEAD BOLT
711507	3/8 FLAT WASHER
711380	3/8-16 NYLOCK NUT
340714	MACHINE BRACKET LEFT
340715	MACHINE BRACKET RIGHT

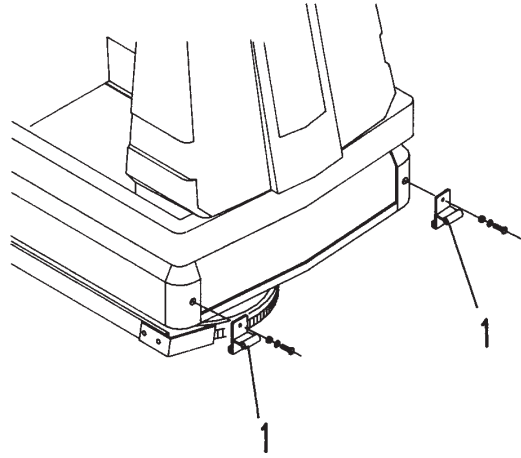

STEP 6

PRESWEEP INSTALLATION

- 1) INSTALL VELCRO TAPE STRIPS ON TOP OF BLACK METAL FRAME JUST UNDER FRONT COWLING, ONE EACH SIDE OF CENTER
- 2) PRESS TOP FLANGE OF REPLACEMENT COVER BETWEEN FRAME AND FRONT COWLING
- 3) SECURE BOTTOM OF REPLACEMENT COVER WITH EXISTING WING BOLTS IN PLACE ON FRAME

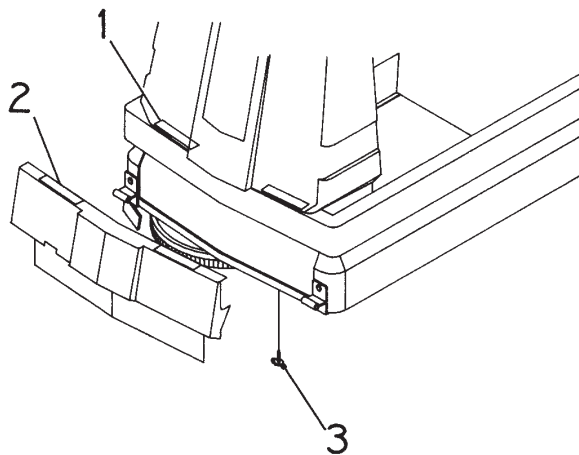

STEP 7

PRESWEEP INSTALLATION

- 1) INSTALL LEVER AND CONTROL BOX WITH FASTENERS PROVIDED.

340748	LEVER CONTROL BOX
340753	LIFT LEVER
710993	1/2-13 x 2.25 SCREW
340744	SPRING

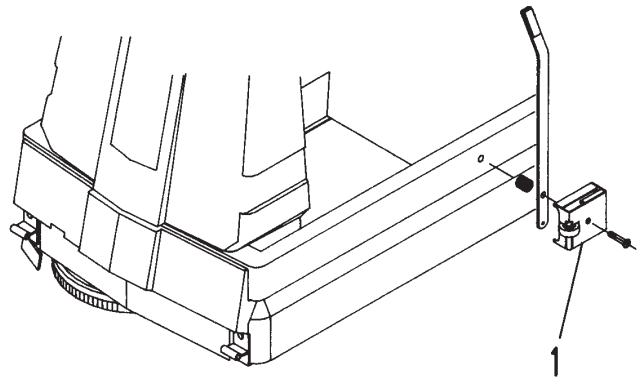

STEP 8

PRESWEEP INSTALLATION

- 1) POSITION AND ALIGN PRESWEEP ASSEMBLY TO MACHINE BRACKETS ATTACHED TO LOWER FRONT CORNERS.
 - 2) LOCK PRESWEEP ONTO BRACKETS USING HITCH PINS AND KEEPER CLIPS AS SHOWN BELOW.
- 340755 HITCH PIN ASSEMBLY
809799 KEEPER CLIP

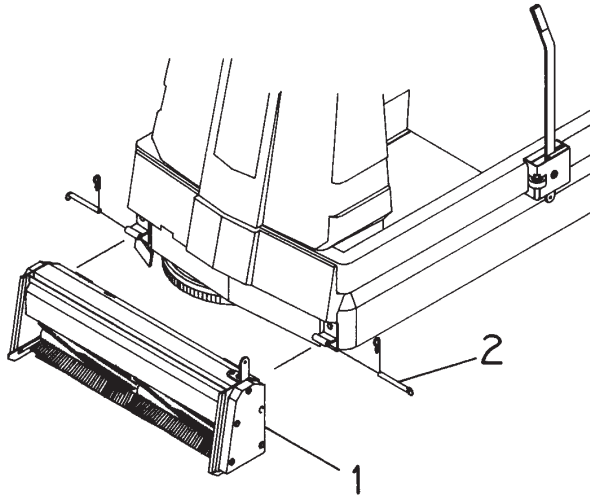

STEP 9

PRESWEEP INSTALLATION

- 1) ATTACH LIFTING STRAP FROM PRESWEEP TO LEVER USING PIN, WASHER, AND KEEPER CLIP.
- 340752 LIFTING STRAP
450034 PIN
711506 5/16 FLAT WASHER
711808 KEEPER CLIP
- 2) RECONNECT POWER TO BATTERY.

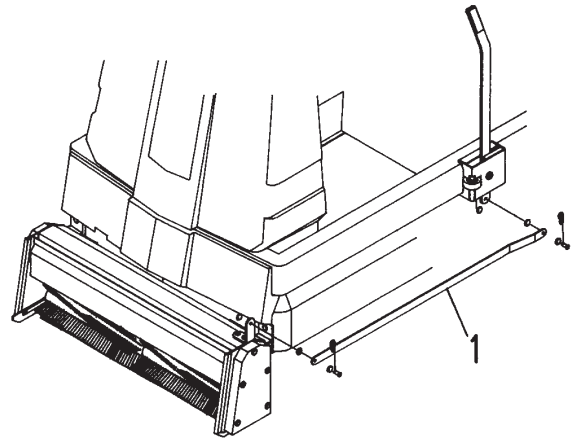

STEP 10

HYDRAULIC CONNECTIONS

- 1) HOOK HOPPER BIN INTO GROOVE ON TOP OF PRESWEEP HOUSING.
 - 2) CONNECT HYDRAULIC LINES TO PRESWEEP BY PULLING COLLAR BACK ON FEMALE COUPLER AND PRESSING FEMALE COUPLER ONTO MALE NIPPLE.
- NOTE: CENTER HYDRAULIC LINE IS SMALLER IN SIZE.

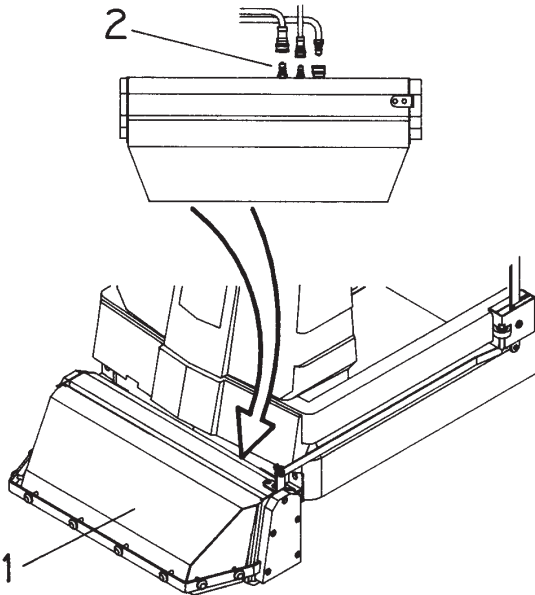

STEP 11

PRESWEEP ADJUSTMENT

- 1) RELEASE CONTROL LEVER TO LOWER PRESWEEP TO CONTACT THE FLOOR.
- 2) LEVEL PRESWEEP TO FLOOR BY ADJUSTING LEVELER BOLTS AT EACH END OF THE PRESWEEP MACHINE.
- 3) WITH PRESWEEP ON-- MOVE THE SCRUBBER FORWARD 3 TO 5 FEET TO ALLOW THE BRUSHES TO LAY OVER.
- 4) TURN OFF PRESWEEP AND SCRUBBER. READJUST AS IN STEP 2.

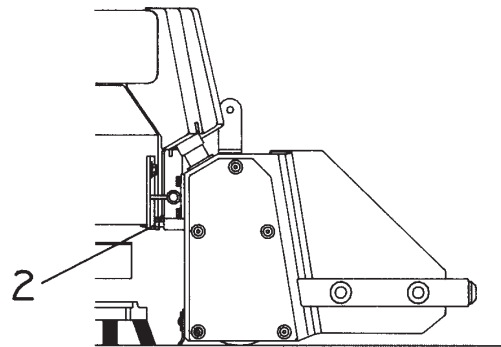

STEP 12

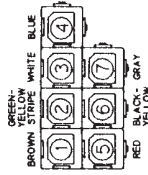
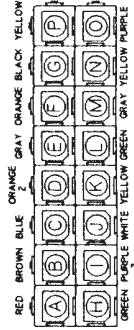
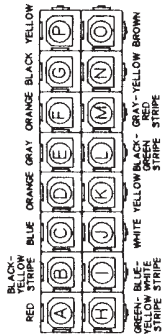

DETAIL FOR WIRE LOCATIONS FOR DASH

DETAIL FOR WIRE LOCATIONS FOR CHASSIS

ELECTRICAL BOX

CHASSIS

WIRING HARNESS COMPLETE (FOR CHASSIS)

WIRING HARNESS COMPLETE (FOR CHASSIS)

WIRING HARNESS COMPLETE (FOR DASH)

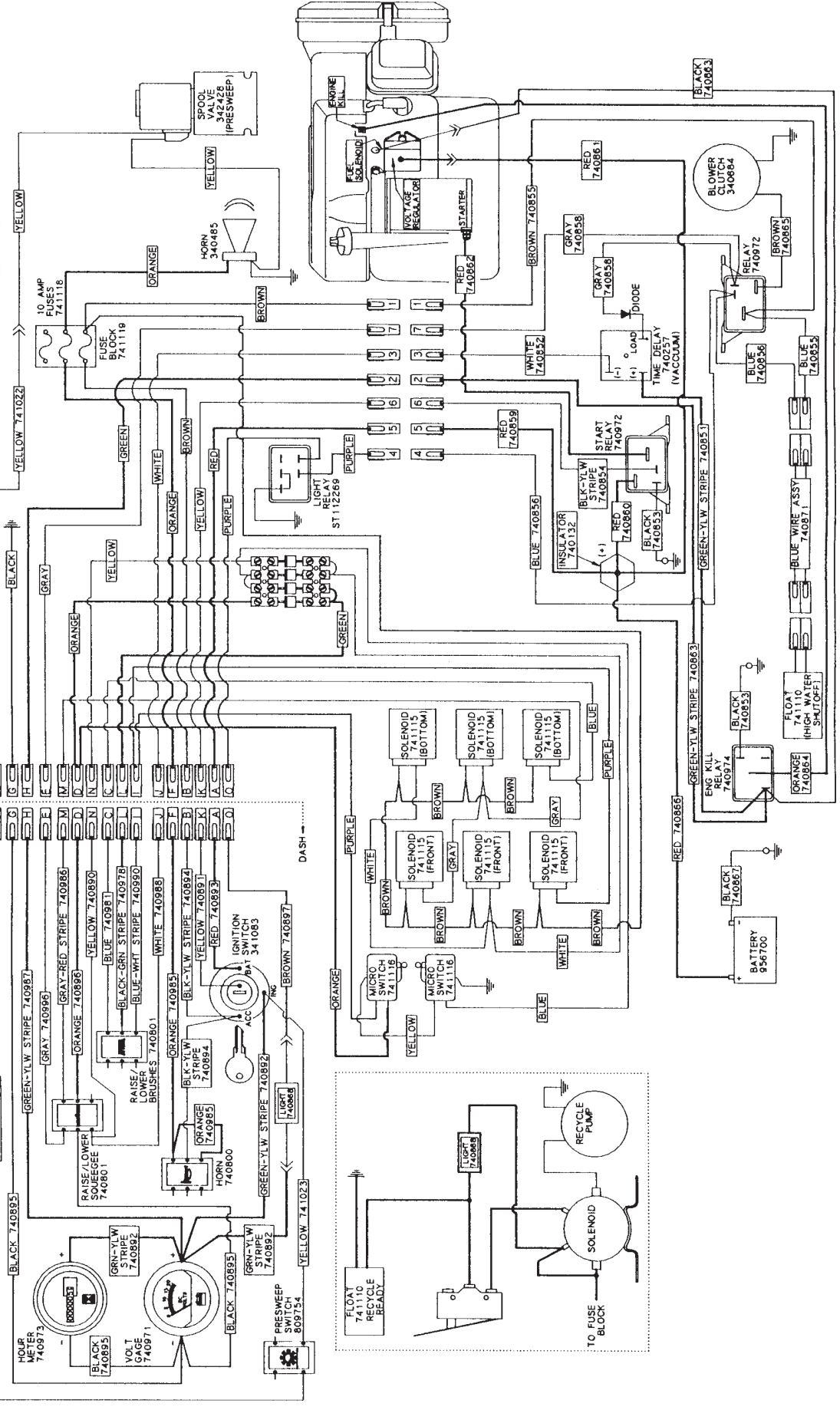

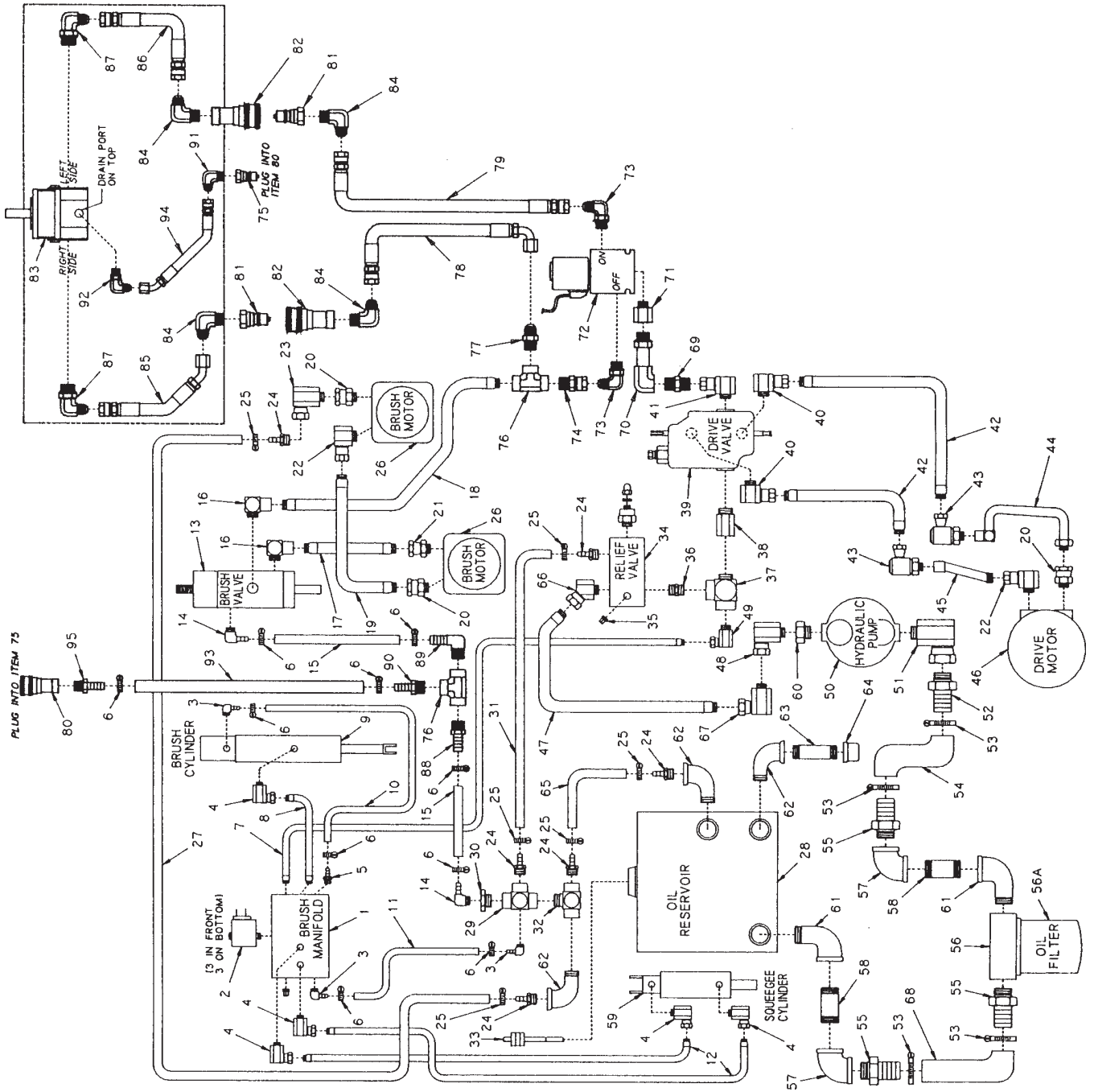

Parts List

Item	Part No.	Qty.	Description	Item	Part No.	Qty.	Description
1	340599	1	Brush Manifold	49	340593	1	Check Valve
2	340539	1	Solenoid Valve Cartridge	50	340528	1	Hydraulic Pump
3	340536	3	Eil	51	341086	1	Street Eil
4	340524	5	Swivel Eil	52	340603	1	Hose BARB
5	340484	1	Fitting	53	760245	4	Hose Clamp
6	829129	10	Microseal Hose Clamp TO 7/8 OD	54	341090	1	7 1/2" Hose
7	341234	1	Hose	55	340526	3	Hose BARB
8	340535	1	Hose	56	340465	1	Filter Assembly
9	340555	1	Brush Cylinder	56A	340621	1	Oil Filter Replacement
10	340541	1	Hose	57	341092	2	3/4" Elbow
11	340542	1	Hose	58	341093	2	3/4" Pipe Nipple 2 1/2"
12	340531	2	Hose	59	340558	1	Squeegee Cylinder
13	340570	1	Brush Valve	60	340525	1	Adapter
14	340538	2	Eil	61	761545	2	3/4" Street 90
15	340570	1	Hose	62	57-81-A	3	1/2" Street 90
16	340530	2	Street Eil	63	341095	1	1/2" Pipe Nipple 4 1/2"
17	340533	1	Hose	64	341096	1	1/2" Pipe Cap
18	340520	1	31" Hose	65	341000	1	Hose
19	340521	1	Hose	66	341239	1	45° Swivel Fitting
20	340537	2	Fitting	67	341089	1	Street Eil
21	340548	1	Fitting	68	341091	1	Hose 3 3/4"
22	340517	1	Fitting	69	342409	1	3/8 MPT TO 3/8 MPT Coupler
23	340516	1	Swivel Eil	70	342410	1	3/8 FPT Extra Long Elbow
24	340523	6	Coupling	71	342411	1	3/4-16 TO 9/16-18 ST Thread Reducer
25	340463	6	Clamp	72	342428	1	Spool Valve
26	340505	2	Brush Motor	73	342412	2	9/16 Straight Thread Elbow
27	340549	1	Hose	74	342413	1	9/16 Female Flare TO 3/8 MPT
28	340695	1	Oil Reservoir	75	828368	1	1/4 FPT TO Male Nipple
29	341235	1	Tee	76	342415	2	3/8 Female Pipe Tee
30	340486	1	Bushing	77	342416	1	3/8 Male Connector
31	340544	1	Hose	78	342426	1	27" Rubber Hose
32	341236	1	Tee	79	342425	1	34" Rubber Hose
33	340565	1	Dipstick	80	828370	1	1/4 FPT TO Female Coupler
34	340550	1	Relief Valve	81	342418	2	3/8 FPT TO Male Nipple
35	340492	1	Plug	82	342419	2	3/8 FPT TO Female Coupler
36	340622	1	Pipe Nipple	83	342427	1	Hydraulic Gear Pump
37	341237	1	Branch Eil	84	342420	4	3/8 Male Elbow
38	340518	1	Adapter	85	342424	1	12" Rubber Hose
39	340545	1	Drive Valve	86	342423	1	20" Rubber Hose
40	340547	2	Fitting	87	342421	2	3/4 TO 9/16 Straight Thread Elbow
41	340546	1	Fitting	88	827008	1	Hose BARB, 1/2" ID Hose - 3/8 MPT
42	340532	2	Hose	89	342429	1	90° Hose BARB, 1/2" ID Hose - 3/8 MPT
43	340519	2	Fitting	90	342430	1	Hose BARB, 3/8" ID Hose - 3/8 MPT
44	340590	1	Hydraulic Line	91	342431	1	Male Elbow, 1/4 MPT - 1/4 Flare
45	340589	1	Hydraulic Line	92	343432	1	Male Elbow, 7/16 UNC - 1/4 Flare
46	340502	1	Drive Motor	93	342434	1	3/8 ID Hose, 9" Long
47	341238	1	Hose	94	342433	1	Presweep Relief Hose
48	341085	1	Street Eil	95	342435	1	Hose BARB, 3/8" ID Hose - 1/4 MPT

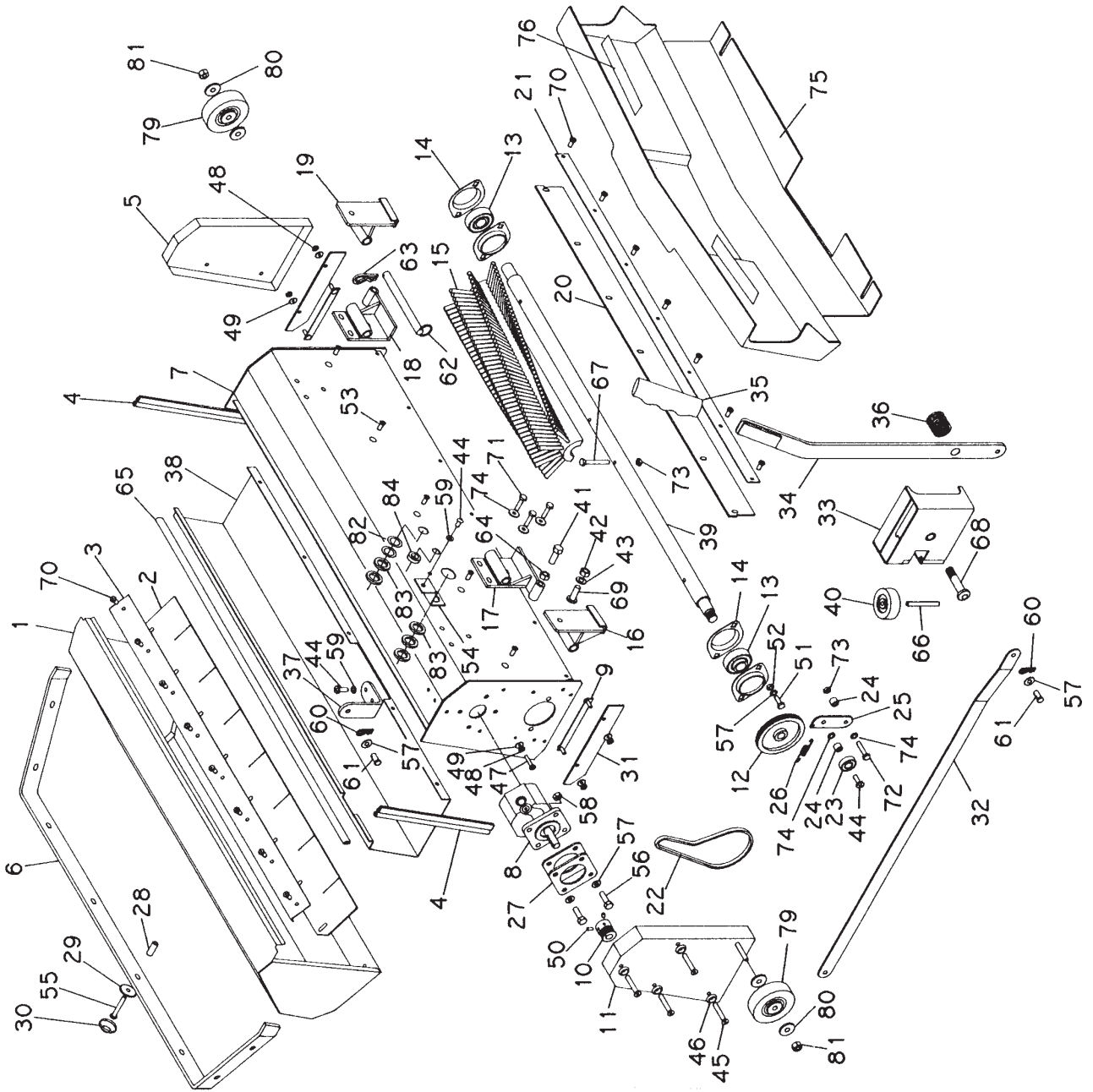

Parts List

Item	Part No.	Qty.	Description	Item	Part No.	Qty.	Description
1	340731	1	Hopper Bin Assembly	43	711507	2	3/8 Flat Washer
2	340735	1	Hopper Skirt	44	710180	4	1/4-20 x 3/4 Truss Head Screw
3	340734	1	Hopper Skirt Plate	45	710600	8	1/4-20 x 1 5/8 FH Machine Screw
4	340732	2	Hopper Bin Seal	46	712319	8	1/4 Dress Washer
5	340713	1	Cover End Idle Side	47	710357	1	10-32 x 3/4 Machine Screw
6	340702	1	Bumper Presweep	48	711350	5	10-32 Nyloc Nut
7	342401	1	Hydraulic Presweep Frame Assy.	49	711503	5	10 Flat Washer
8	342427	1	Hydraulic Gear Pump	50	711003	2	10-32 Set Screw
9	340725	2	Side Skirt Plate	51	711228	4	5/16-18 x 3/4 H.H. Bolt
10	342406	1	Presweep Pump Pulley	52	711374	4	5/16-18 Nyloc Nut
11	340712	1	End Cover Drive Side	53	712818	5	10-24 x 1/2 F.H.M.S.
12	340739	1	Drive Pulley Brush	54	342407	1	Coupler Bracket
13	881059	2	3/4" Bearing	55	710385	8	1/4-20 x 1.5 MCH Screw
14	340742	4	Bearing Flange	56	713027	4	5/16-18 Hex Head Bolt (gr. 5)
15	340701	2	Brush, Set of 2 Halves	57	711506	10	5/16 Flat Washer
16	340715	1	Machine Bracket Right	58	711383	4	5/16-18 Center Lock Nut
17	340723	1	Presweep Brake Right	59	711544	3	1/4 Lock Washer
18	340722	1	Presweep Bracket Left	60	711808	2	Retainer Pin Small
19	340714	1	Machine Bracket Left	61	450034	2	Clevis Pin
20	340738	1	Rear Presweep Skirt	62	340755	2	Pin Presweep Hitch
21	340724	1	Rear Skirt Plate	63	833374	2	Retainer Pin Large
22	340746	1	Poly V Belt	64	711391	2	3/8-16 Jam Nut
23	828588	1	Bearing	65	340757	1	Cover Seal
24	762371	2	Bushing .25 x .50 x .37	66	711660	1	Rollpin 1/4 x 2.5
25	340733	1	Belt Tension Arm	67	711220	4	1/4-20 x 2.50 H.H. Bolt
26	762084	1	Spring	68	710993	1	1/2-13 x 2.25 Screw
27	342405	2	Presweep Pump Spacer	69	710986	2	3/8-16 x 1 T.H.A.D.S.
28	762399	8	Spacer	70	712822	15	10-24 x 1/2 Truss Head Screw
29	762314	8	Cap Washer	71	711203	6	1/4-20 x 5/8 HH Bolt
30	762313	8	Black Cap	72	711207	1	1/4-20 x 1 HH Bolt
31	340743	2	Presweep Side Skirt	73	711373	5	1/4-20 Nyloc Nut
32	340752	1	Lift Strap	74	711505	8	1/4 Flat Washer
33	340748	1	Lever Control Box	75	340756	1	Plastic Nose Cover
34	340753	1	Lift Lever Weldment	76	832635	4	6" Velcro Strip
35	762086	1	Hand Grip	77	809754	1	Rocker Switch (not shown)
36	340744	1	Lever Spring	78	802657	1	Boot Switch Cover (not shown)
37	340750	1	Presweep Lift Bracket	79	808829	2	Wheel 3"
38	342408	1	Hydraulic Pump Front cover	80	711508	4	3/8" Washer
39	340740	1	Presweep Brush Axle	81	711375	2	3/8-16 1/2 Nyloc Nut
40	828214	1	Caster Wheel	82	711513	2	.70 ID x 1.063 OD x .031 Washer
41	711242	2	3/8-16 x 1 HH Bolt	83	712318	5	.70 ID x 1.125 OD x .140 Washer
42	711380	2	3/8-16 Nyloc Nut	84	500022	1	.55 ID x .87 OD x .25 Spacer

LIMITED WARRANTY

Minuteman International, Inc. warrants to the original purchaser/user that this product is free from defects in workmanship and materials under normal use and service for a period of three years from date of purchase. In addition, Minuteman International, Inc. will, at its option, honor labor warranty claims for the first 12 months from date of sale, provided such claims are submitted through and approved by factory authorized repair stations. Minuteman International, Inc. will, at its option, repair or replace without charge, except for transportation costs, parts that fail under normal use and service when operated and maintained in accordance with the applicable operation and instruction manuals.

This warranty does not apply to normal wear, or to items whose life is dependent on their use and care, such as belts, cords, switches, hoses, rubber parts, electrical motor components or adjustments. Parts not manufactured by Minuteman International, Inc. such as engines, batteries, battery chargers, hydraulic pumps, and tires are covered by and subject to the warranties and/or guarantees of their manufacturers. Please contact Minuteman International, Inc. for procedures in warranty claims against these manufacturers.

Special warning to purchaser — Use of replacement filters and/or prefilters not manufactured by Minuteman International, Inc. or its designated licensees, will void all warranties expressed or implied.

A potential health hazard exists without exact original equipment replacement.

All warranted items become the sole property of Minuteman International, Inc. or its original manufacturer, whichever the case may be.

Minuteman International, Inc. disclaims any implied warranty, including the warranty of merchantability and the warranty of fitness for a particular purpose. Minuteman International, Inc. assumes no responsibility for any special, incidental or consequential damages.

This limited warranty is applicable only in the U.S.A. and Canada, and is extended only to the original user/purchaser of this product. Customers outside the U.S.A. and Canada should contact their local distributor for export warranty policies. Minuteman International, Inc. is not responsible for costs or repairs performed by persons other than those specifically authorized by Minuteman International, Inc. This warranty does not apply to damage from transportation, alterations by unauthorized persons, misuse or abuse of the equipment, use of non-compatible chemicals, or damage to property, or loss of income due to malfunctions of the product.

If a difficulty develops with this machine, you should contact the dealer from whom it was purchased.

This warranty gives you specific legal rights, and you may have other rights which vary from state to state. Some states do not allow the exclusion or limitation of special, incidental or consequential damages, or limitations on how long an implied warranty lasts, so the above exclusions and limitations may not apply to you.

Minuteman[®]

World Headquarters
Minuteman International, Inc.
111 South Rohlwing Road
Addison, Illinois 60101

Minuteman Canada, Inc.
2210 Drew Road
Mississauga, Ontario
L5S 1B1

(630) 627-6900
FAX (630) 627-1130

(905) 673-3222
FAX (905) 673-5161

987961
Printed in U.S.A.