



# MICROMAG

## Parts Manual (EN)

### MODELS:

*17" Disk Traction  
20" Disk Traction*

*17" Disk Pad Assist  
20" Disk Pad Assist*

*20" Orbital Traction*

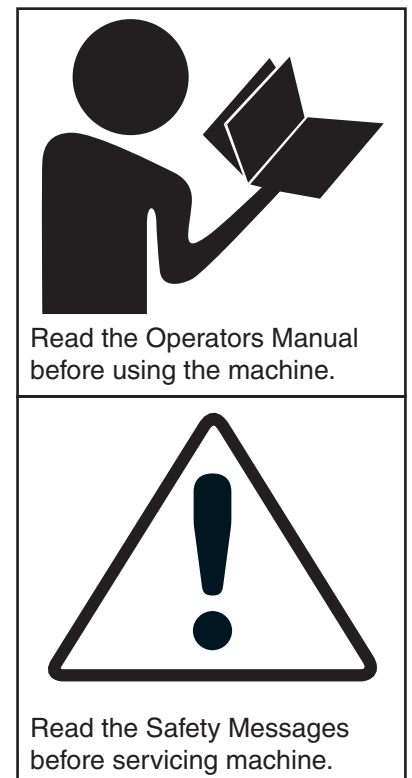
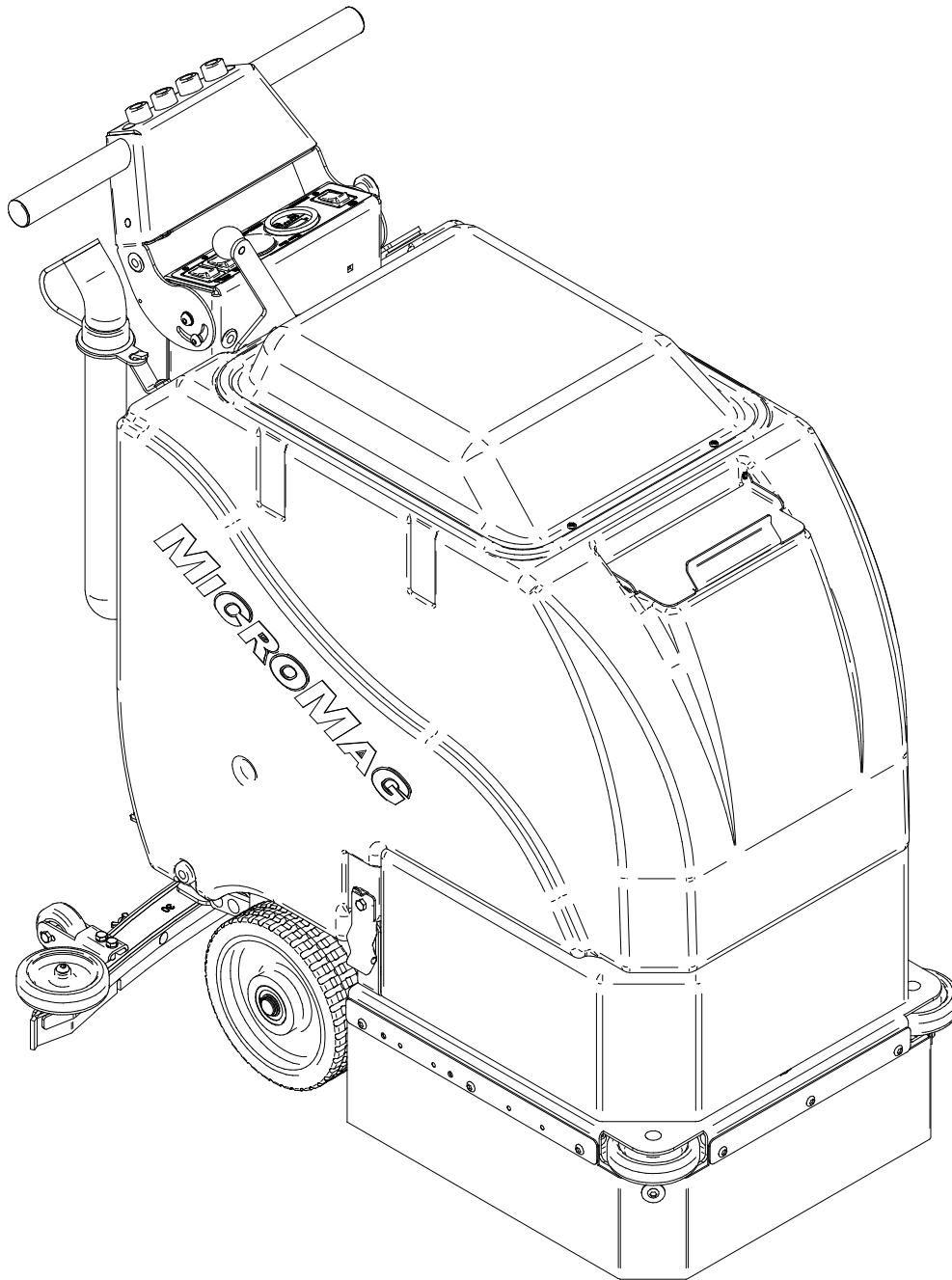

Read the Operators Manual  
before using the machine.

Read the Safety Messages  
before servicing machine.



# Table of Contents

---

17 Inch Frame - Pad Drive .....	4
17 Inch Frame - Traction Drive .....	6
20 Inch Frame - Pad Drive .....	8
20 Inch Frame - Traction Drive .....	10
20 Inch EDGE Frame - Traction Drive.....	12
Batteries and Chargers.....	14
Solution Flow Filter .....	16
Central Command - Pad Drive .....	18
EDGE Central Command - Traction Drive.....	20
Squeegee Drag Link Assembly .....	22
Clean Caddy.....	24
Common Wear Parts .....	25
Common Wear Parts .....	26

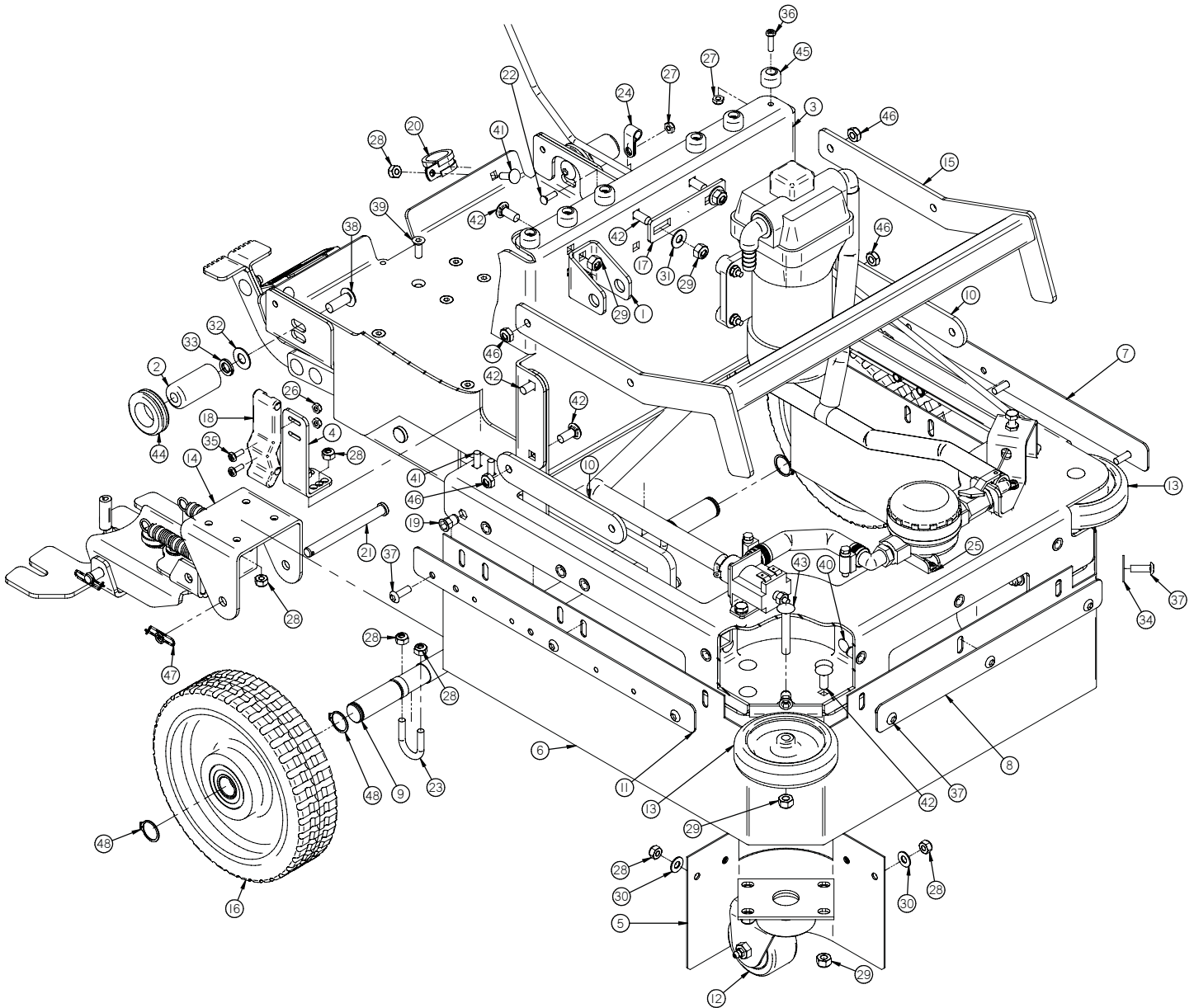

Item	Part No.	Part Description	Qty.	Item	Part No.	Part Description	Qty.
1	150-1006	LIFTING BRACKET	1	25	H-02309	HCN #10-32 LG CRIMP	4
2	150-1060	BOSS	2	26	H-70856	NYLOK #8-32 SS	4
3	150-1100	17 INCH MAIN FRAME PAD DRIVE	1	27	H-70858	NYLOK #10-32 SS	7
4	150-1124	LATCH BRACKET	2	28	H-70860	NYLOK 1/4"- 20 SS	24
5	150-1165	CASTER CURTAIN	2	29	H-70861	NYLOK 5/16" - 18 SS	14
6	150-1166	FRAME CURTAIN (17" BRUSH)	1	30	H-71013	FW 1/4 ID X 5/8 OD SS	10
7	150-1168	FRAME SIDE CURTAIN BAND (17" LHI)	1	31	H-71015	FW 5/16 ID X 3/4 OD SS	2
8	150-1169	MAIN FRAME FRONT CURTAIN BAND	1	32	H-71017	FW 3/8 ID X 7/8 OD SS	2
9	150-1171	AXLE	1	33	H-71067	LW 3/8" SS	2
10	150-1240	LATERAL ARM	2	34	H-71212	FNW 1/4 ID X 1.0 OD SS	2
11	150-1268	FRAME SIDE CURTAIN BAND (17" RH)	1	35	H-72398	PPH #8-32 X 1/2" S/S	4
12	150-3030	CASTER	2	36	H-72534	PPH #10-32 X 3/4" S/S	6
13	150-7600	4" SIDE WHEEL (GREY)	2	37	H-73754	BHSCS 1/4 - 20 X 3/4" SS	11
14	150-7611	SQUEEGEE DRAG BRACKET	1	38	H-73817	BHSCS 3/8" - 16 X 1-1/2" SS	2
15	150-9586	LATERAL ARM	1	39	H-73882	FHSCS 1/4- 20 X 3/4" S/S	6
16	170-6185	DRIVE TIRE, GRAY POLY	2	40	H-74418	CB 1/4"- 20 X 5/8" S/S	8
17	253-1040	TANK STRAP SUPPORT	1	41	H-74419	CB 1/4"- 20 X 7/5" SS	5
18	4-124	LATCH	2	42	H-74429	CB 5/16"- 18 X 3/4" SS	16
19	H-00918	HCN 1/4"-20 LG	17	43	H-74433	CB 5/16"- 18 X 2" SS	2
20	H-0127296	1.0" LOOP CLAMP	1	44	H-9307K74	GROMMET, 1" ID X 1-3/4" OD BUNA-N	2
21	H-0156759	3/8" X 4" CLEVIS PIN (ZINK)	1	45	H-9540	RUBBER BUMPER, 25/32"	6
22	H-0172519	CB #10-32 X 5/8" SS	1	46	H-NJ05C	JNYL 5/16"- 18 SS	4
23	H-0175683	U-BOLT .25 -20 X .375 X 1.25 SS	2	47	H-RUE14	3/8" RUE RING COTTER	1
24	H-02239	3/8" VINYL LOOP CLAMP	1	48	M-98585A115	SNAPRING 3/4" HEAVY DUTY	4

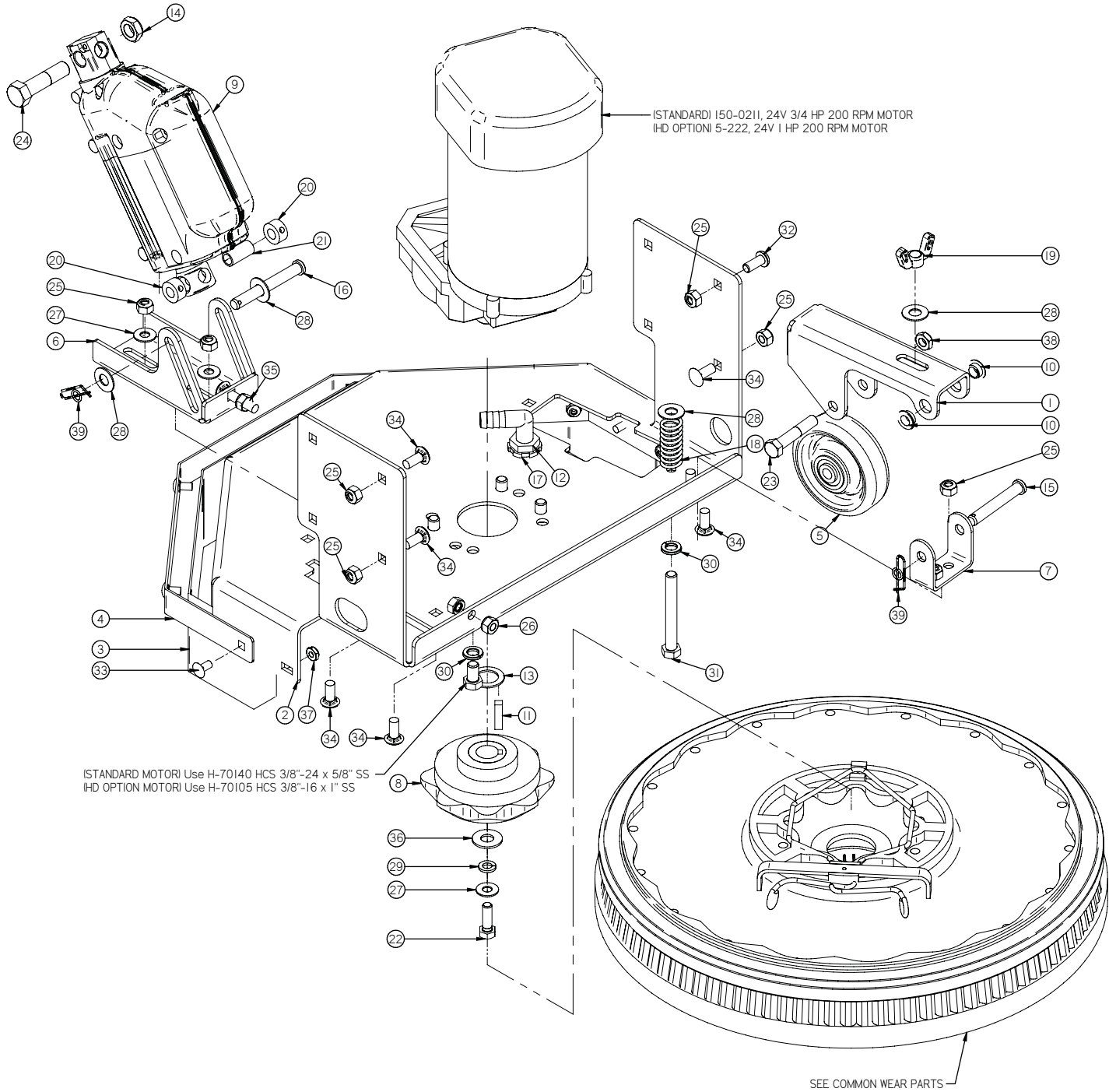

(STANDARD MOTOR) Use H-70140 HCS 3/8"-24 x 5/8" SS  
 (HD OPTION MOTOR) Use H-70105 HCS 3/8"-16 x 1" SS

SEE COMMON WEAR PARTS

Item	Part No.	Part Description	Qty.	Item	Part No.	Part Description	Qty.
1	150-1030	DECK WHEEL PIVOT BRACKET	1	21	H-63917	SLEEVE, .50 OD X .375 ID X 1.0 LG	1
2	150-1125	DISK DECK PLATFORM, 17"	1	22	H-70055	HCS 5/16"- 18 X 1" SS	1
3	150-1170	DISK DECK CURTAIN, 17"	1	23	H-70111	HCS 3/8"- 16 X 2" SS	1
4	150-1175	DISK DECK CURTAIN BAND, 17"	1	24	H-70211	HCS 1/2"-13 X 2.0" SS	1
5	150-3020	WHEEL, 3-1/2 x 1-3/8, POLY GREY	1	25	H-70861	NYLOK 5/16" - 18 SS	8
6	150-9003	LIFTING BRACKET	1	26	H-70926	KN 15/16-18 S/S	3
7	190-1035	DECK WHEEL PIVOT SUPPORT	1	27	H-71015	FW 5/16 ID X 3/4 OD SS	3
8	21-5000	BRUSH DRIVER	1	28	H-71017	FW 3/8 ID X 7/8 OD SS	4
9	253-2240	2" STROKE, 24V ACTUATOR 450 LB LOAD	1	29	H-71065	LW 5/16" SS	1
10	290-1233	3/8" ID, 1/2" OD, 1/4" LG BEARING	2	30	H-71067	LW 3/8" SS	5
11	5-431	1/4" X 1" KEY	1	31	H-71191	HCS 3/8"- 16 X 3" SS	1
12	5-447	1/2 NPT X 1/2" BARB ELBOW	1	32	H-73779	BHSCS 5/16-18 X 3/4"	1
13	H-00222	FW 3/4" ID X 1 1/8" OD X 3/32" SS	1	33	H-74417	CB 1/4"- 20 X 5" SS	6
14	H-0129159	JNYL, 1/2"-13, 18-8 SS	1	34	H-74429	CB 5/16"- 18 X 3/4" SS	7
15	H-0156754	CLEVIS PIN, 3/8" X 2-1/2" (ZINK)	1	35	H-74432	CB 5/16"- 18 X 1-1/2" SS	1
16	H-0156756	CLEVIS PIN 3/8" x 3.00"	1	36	H-99001	FW 3/8" SS	1
17	H-07005	1/2" NPT LOCKNUT	2	37	H-NJ04C	JNYL 1/4" - 20 SS	6
18	H-111	SPRING, 1/2" ID X 2-1/2" LG	1	38	H-NJ06C	JNYL 3/8- 16 SS	1
19	H-11101613	WINGNUT 3/8-16, NYLOK SS	1	39	H-RUE14	3/8" RUE RING COTTER	2
20	H-33372	SHAFT COLLAR, 3/8" ID	2				

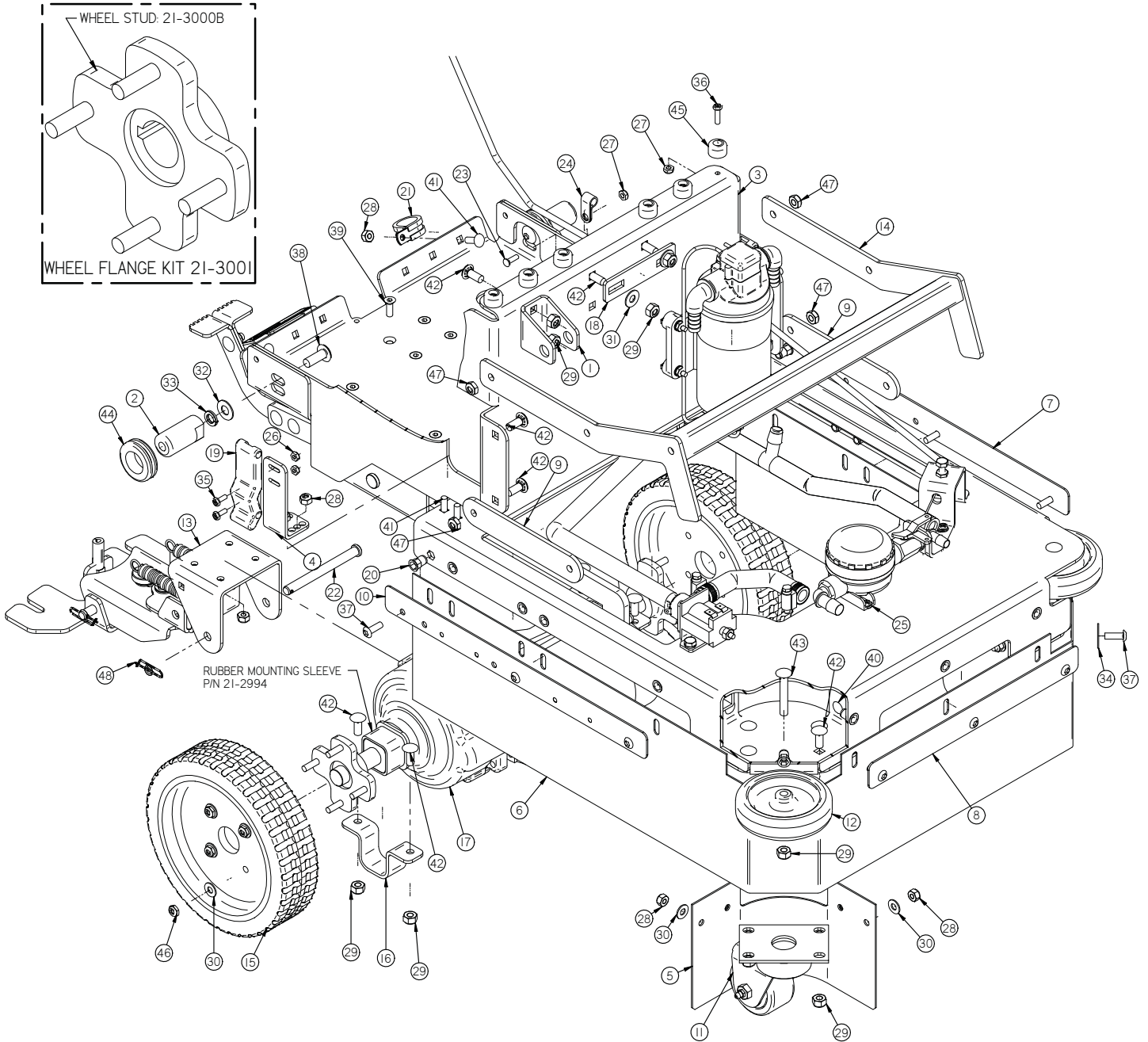

Item	Part No.	Part Description	Qty.	Item	Part No.	Part Description	Qty.
1	150-1006	LIFTING BRACKET	1	25	H-02309	HCN #10-32, LG CRIMP	4
2	150-1060	BOSS	2	26	H-70856	NYLOK #8-32 SS	4
3	150-1102	17 INCH MAIN FRAME TRACTION DRIVE	1	27	H-70858	NYLOK #10-32 SS	7
4	150-1124	LATCH BRACKET	2	28	H-70860	NYLOK 1/4"- 20 SS	20
5	150-1165	CASTER CURTAIN	2	29	H-70861	NYLOK 5/16" - 18 SS	18
6	150-1167	MAIN FRAME CURTAIN, (17" TRACI	1	30	H-71013	FW 1/4 ID X 5/8 OD SS	16
7	150-1168	FRAME SIDE CURTAIN BAND (17" LHI	1	31	H-71015	FW 5/16 ID X 3/4 OD SS	2
8	150-1169	MAIN FRAME FRONT CURTAIN BAND	1	32	H-71017	FW 3/8 ID X 7/8 OD SS	2
9	150-1240	LATERAL ARM	2	33	H-71067	LW 3/8" SS	2
10	150-1268	FRAME SIDE CURTAIN BAND (17" RH)	1	34	H-71212	FNW 1/4 ID X 1.0 OD SS	2
11	150-3030	CASTER	2	35	H-72398	PPH #8-32 X 1/2" S/S	4
12	150-7600	4" SIDE WHEEL (GREY)	2	36	H-72534	PPH #10-32 X 3/4" S/S	6
13	150-7611	SQUEEGEE DRAG BRACKET	1	37	H-73754	BHSCS 1/4 - 20 X 3/4" SS	11
14	150-9586	LATERAL ARM	1	38	H-73817	BHSCS 3/8"- 16 X 1-1/2" SS	2
15	170-6180	8" WHEEL COUNTRY TREAD	2	39	H-73882	FHSCS 1/4- 20 X 3/4" S/S	6
16	21-1010	AXLE MOUNT	2	40	H-74418	CB 1/4"- 20 X 5/8" S/S	8
17	21-3009	TRANSAXLE	1	41	H-74419	CB 1/4"- 20 X 7.5" SS	5
18	253-1040	TANK STRAP SUPPORT	1	42	H-74429	CB 5/16"- 18 X 3/4" SS	20
19	4-124	LATCH	2	43	H-74433	CB 5/16"- 18 X 2" SS	2
20	H-00918	HCN 1/4"-20 LG	17	44	H-9307K74	GROMMET, 1" ID X 1-3/4" OD BUNA-N	2
21	H-0127296	1.0" LOOP CLAMP	1	45	H-9540	RUBBER BUMPER, 25/32"	6
22	H-0156759	3/8" X 4" CLEVIS PIN (ZINKI)	1	46	H-NJ04C	JNYL 1/4" - 20 SS	8
23	H-0172519	CB #10-32 X 5/8" SS	1	47	H-NJ05C	JNYL 5/16"- 18 SS	4
24	H-02239	3/8" VINYL LOOP CLAMP	1	48	H-RUE14	3/8" RUE RING COTTER	1

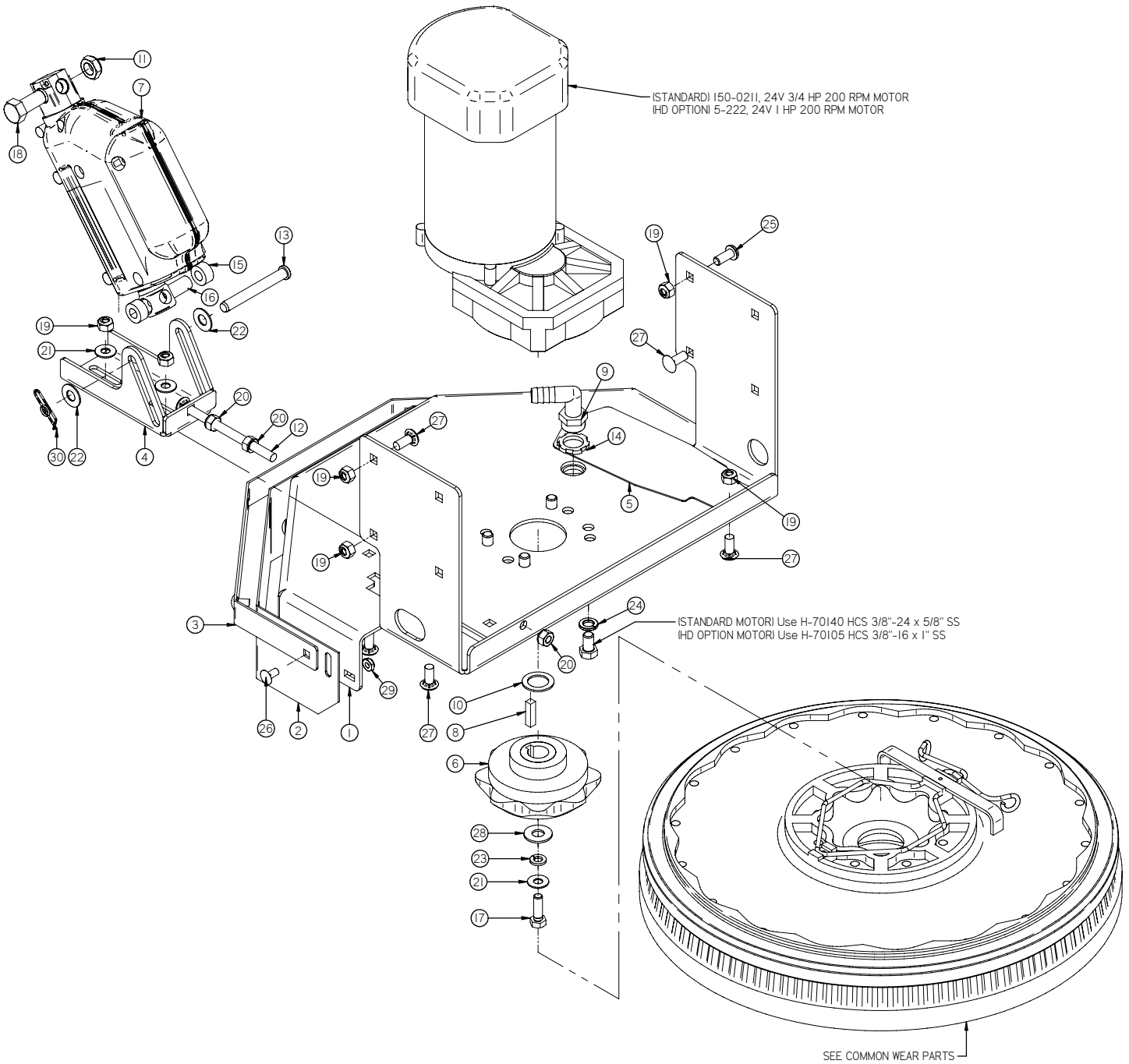

Item	Part No.	Part Description	Qty.	Item	Part No.	Part Description	Qty.
1	150-1125	DISK DECK PLATFORM, 17"	1	16	H-63917	SLEEVE, .50 OD X .375 ID X 1.0 LG	1
2	150-1170	DISK DECK CURTAIN, 17"	1	17	H-70055	HCS 5/16"- 18 X 1" SS	1
3	150-1175	DISK DECK CURTAIN BAND, 17"	1	18	H-70211	HCS 1/2"-13 X 2.0" SS	1
4	150-9003	LIFTING BRACKET	1	19	H-70861	NYLOK 5/16" - 18 SS	8
5	170-1030	DISK DECK COVER PLATE	1	20	H-70926	KN 15/16-18 S/S	3
6	21-5000	BRUSH DRIVER	1	21	H-71015	FW 5/16 ID X 3/4 OD SS	3
7	253-2240	2" STROKE 24V ACTUATOR 450 LB LOAD	1	22	H-71017	FW 3/8 ID X 7/8 OD SS	2
8	5-431	1/4" X 1" KEY	1	23	H-71065	LW 5/16" SS	1
9	5-447	1/2 NPT X 1/2" BARB ELBOW	1	24	H-71067	LW 3/8" SS	4
10	H-00222	FW 3/4" ID X 1 1/8" OD X 3/32" SS	1	25	H-73779	BHSCS 5/16-18 X 3/4"	1
11	H-0129159	JNYL, 1/2"-13, 18-8 SS	1	26	H-74417	CB 1/4"- 20 X .5" SS	6
12	H-0144096	CB 5/16"- 18 X 4.5" ZINK	1	27	H-74429	CB 5/16"- 18 X 3/4" SS	7
13	H-0156756	CLEVIS PIN 3/8" x 3.00"	1	28	H-99001	FW 3/8" SS	1
14	H-07005	1/2" NPT LOCKNUT	2	29	H-NJ04C	JNYL 1/4" - 20 SS	6
15	H-33372	SHAFT COLLAR, 3/8" ID	2	30	H-RUE14	3/8" RUE RING COTTER	1



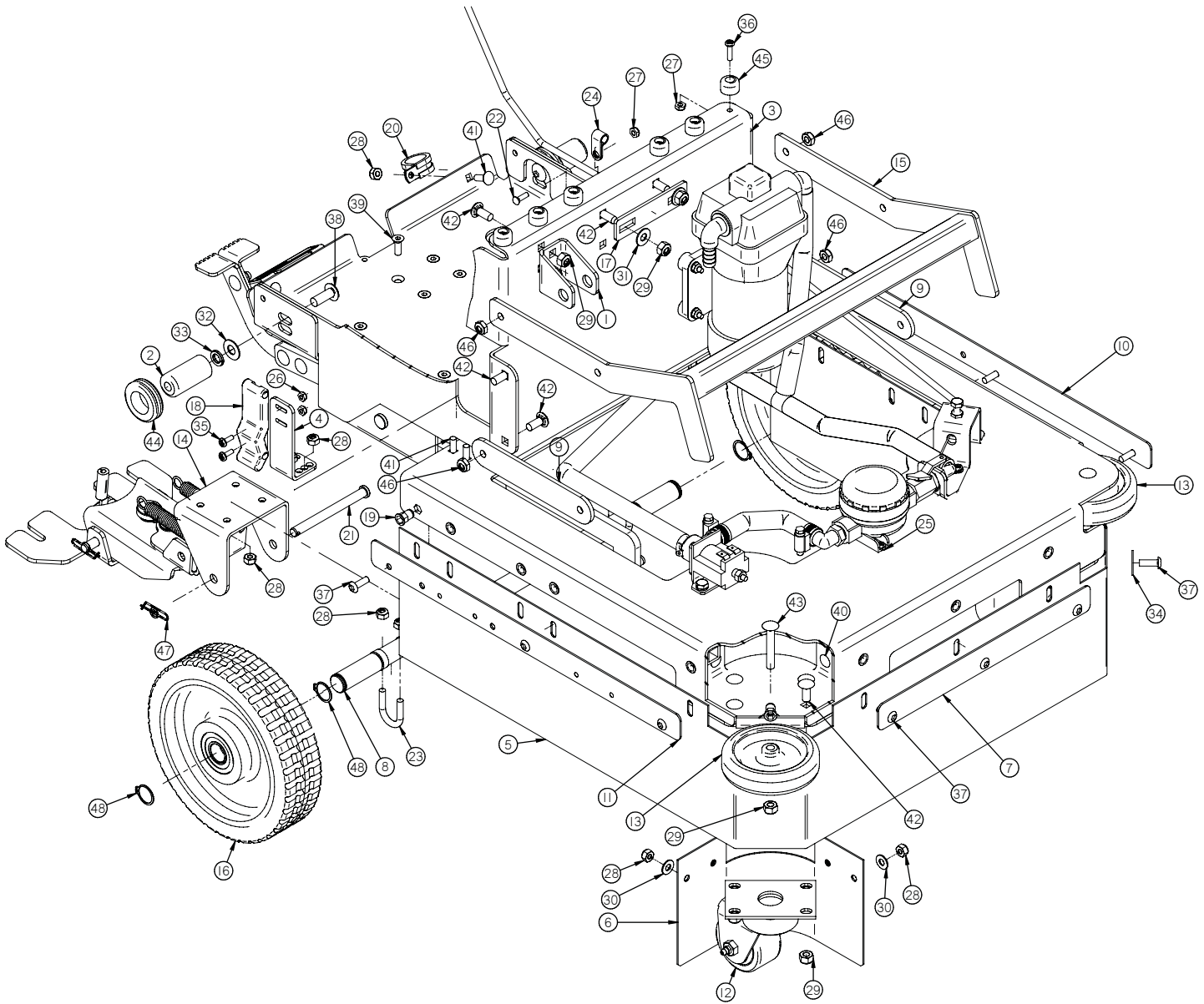

Item	Part No.	Part Description	Qty.	Item	Part No.	Part Description	Qty.
1	150-1006	LIFTING BRACKET	1	25	H-02309	HCN #10-32, LG CRIMP	4
2	150-1060	BOSS	2	26	H-70856	NYLOK #8-32 SS	4
3	150-1101	20 INCH MAIN FRAME PAD DRIVE	1	27	H-70858	NYLOK #10-32 SS	7
4	150-1124	LATCH BRACKET	2	28	H-70860	NYLOK 1/4" - 20 SS	24
5	150-1156	MAIN FRAME CURTAIN (20" BRUSH)	1	29	H-70861	NYLOK 5/16" - 18 SS	14
6	150-1165	CASTER CURTAIN	2	30	H-71013	FW 1/4" ID X 5/8" OD SS	10
7	150-1169	MAIN FRAME FRONT CURTAIN BAND	1	31	H-71015	FW 5/16" ID X 3/4" OD SS	2
8	150-1171	AXLE	1	32	H-71017	FW 3/8" ID X 7/8" OD SS	2
9	150-1240	LATERAL ARM	2	33	H-71067	LW 3/8" SS	2
10	150-1368	FRAME SIDE CURTAIN BAND (20" LHI)	1	34	H-71212	FNW 1/4" ID X 1.0 OD SS	2
11	150-1468	FRAME SIDE CURTAIN BAND (20" RHI)	1	35	H-72398	PPH #8-32 X 1/2" S/S	4
12	150-3030	CASTER	2	36	H-72534	PPH #10-32 X 3/4" S/S	6
13	150-7600	4" SIDE WHEEL (GREY)	2	37	H-73754	BHSCS 1/4" - 20 X 3/4" SS	11
14	150-7611	SQUEEGEE DRAG BRACKET	1	38	H-73817	BHSCS 3/8" - 16 X 1-1/2" SS	2
15	150-9586	LATERAL ARM	1	39	H-73882	FHSCS 1/4" - 20 X 3/4" S/S	6
16	170-6185	DRIVE TIRE, GRAY POLY	2	40	H-74418	CB 1/4" - 20 X 5/8" S/S	8
17	253-1040	TANK STRAP SUPPORT	1	41	H-74419	CB 1/4" - 20 X 7.5" SS	5
18	4-124	LATCH	2	42	H-74429	CB 5/16" - 18 X 3/4" SS	16
19	H-00918	HCN 1/4"-20 LG	17	43	H-74433	CB 5/16" - 18 X 2" SS	2
20	H-0127296	1.0" LOOP CLAMP	1	44	H-9307K74	GROMMET, 1" ID X 1-3/4" OD BUNA-N	2
21	H-0156759	3/8" X 4" CLEVIS PIN (ZINK)	1	45	H-9540	RUBBER BUMPER, 25/32"	6
22	H-0172519	CB #10-32 X 5/8" SS	1	46	H-NJ05C	JNYL 5/16" - 18 SS	4
23	H-0175683	U-BOLT .25 - 20 X .375 X 1.25 SS	2	47	H-RUE14	3/8" RUE RING COTTER	1
24	H-02239	3/8" VINYL LOOP CLAMP	1	48	M-98585A115	SNAPRING 3/4" HEAVY DUTY	4



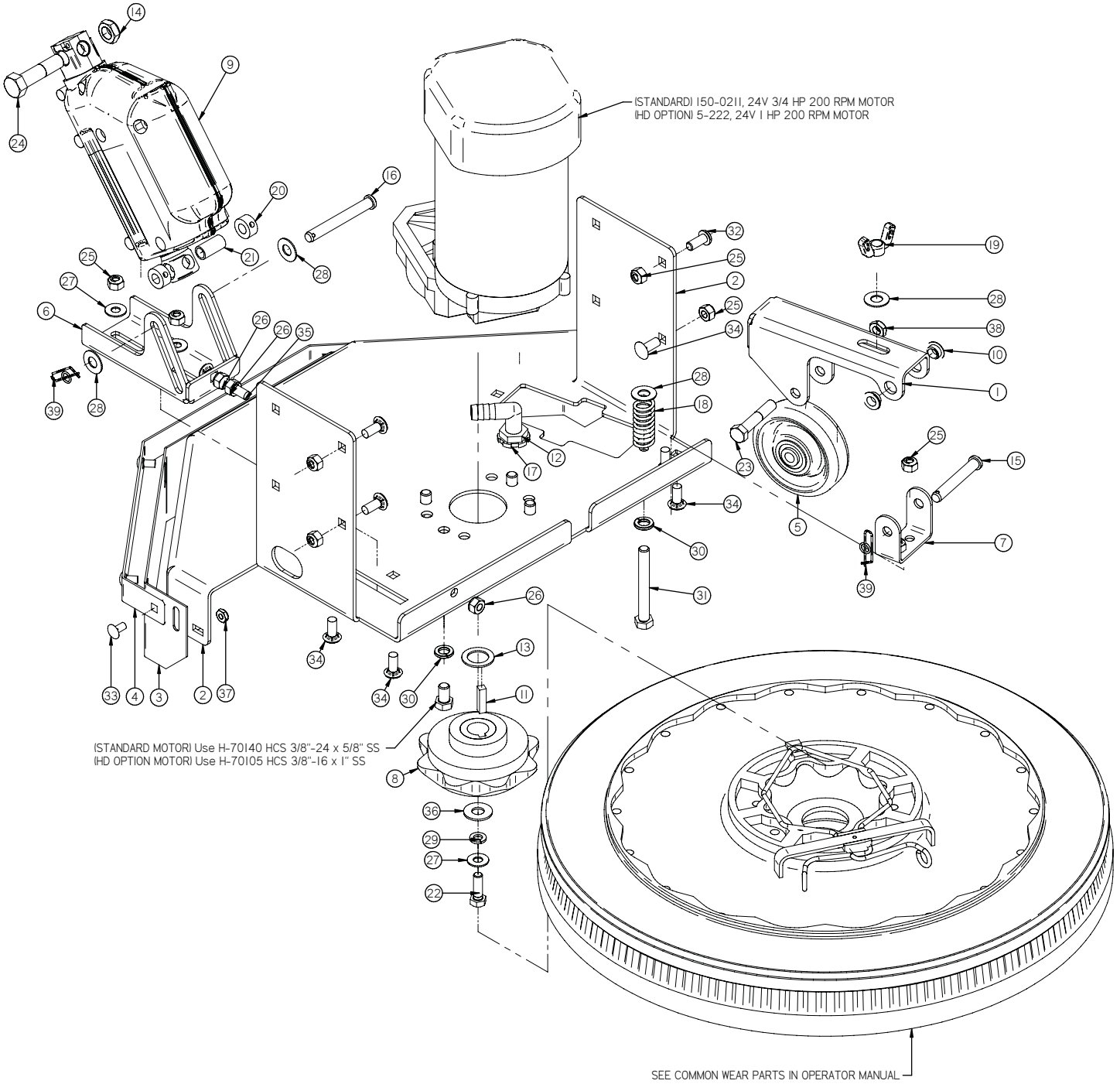

(STANDARD MOTOR) Use H-70140 HCS 3/8"-24 x 5/8" SS  
 (HD OPTION MOTOR) Use H-70105 HCS 3/8"-16 x 1" SS

Item	Part No.	Part Description	Qty.	Item	Part No.	Part Description	Qty.
1	150-1030	DECK WHEEL PIVOT BRACKET	1	21	H-63917	SLEEVE, 50 OD X .375 ID X 1.0 LG	1
2	150-1120	DISK DECK PLATFORM, 20"	1	22	H-70055	HCS 5/16"- 18 X 1" SS	1
3	150-1172	DISK DECK CURTAIN, 20"	1	23	H-70111	HCS 3/8"- 16 X 2" SS	1
4	150-1176	DISK DECK CURTAIN BAND, 20"	1	24	H-70211	HCS 1/2"-13 X 2.0" SS	1
5	150-3020	WHEEL, 3-1/2 x 1-3/8, POLY GREY	1	25	H-70861	NYLOK 5/16"- 18 SS	8
6	150-9003	LIFTING BRACKET	1	26	H-70926	KN 15/16-18 S/S	3
7	190-1035	DECK WHEEL PIVOT SUPPORT	1	27	H-71015	FW 5/16 ID X 3/4 OD SS	3
8	21-5000	BRUSH DRIVER	1	28	H-71017	FW 3/8 ID X 7/8 OD SS	4
9	253-2240	2" STROKE 24V ACTUATOR 450 LB LOAD	1	29	H-71065	LW 5/16" SS	1
10	290-1233	3/8" ID, 1/2" OD, 1/4" LG BEARING	2	30	H-71067	LW 3/8" SS	5
11	5-431	1/4" X 1" KEY	1	31	H-71191	HCS 3/8"- 16 X 3" SS	1
12	5-447	1/2 NPT X 1/2" BARB ELBOW	1	32	H-73779	BHSCS 5/16-18 X 3/4"	1
13	H-00222	FW 3/4" ID X 1 1/8" OD X 3/32" SS	1	33	H-74417	CB 1/4"- 20 X .5" SS	6
14	H-0129159	JNYL, 1/2"-13, 18-8 SS	1	34	H-74429	CB 5/16"- 18 X 3/4" SS	7
15	H-0156754	CLEVIS PIN, 3/8" X 2-1/2" (ZINK)	1	35	H-74433	CB 5/16"- 18 X 2" SS	1
16	H-0156756	CLEVIS PIN 3/8" x 3.00"	1	36	H-99001	FW 3/8" SS	1
17	H-07005	1/2" NPT LOCKNUT	2	37	H-NJ04C	JNYL 1/4" - 20 SS	6
18	H-111	SPRING, 1/2" ID X 2-1/2" LG	1	38	H-NJ06C	JNYL 3/8- 16 SS	1
19	H-11101613	WINGNUT 3/8-16, NYLOK SS	1	39	H-RUE14	3/8" RUE RING COTTER	2
20	H-33372	SHAFT COLLAR, 3/8" ID	2				

# 10 20 Inch Frame - Traction Drive

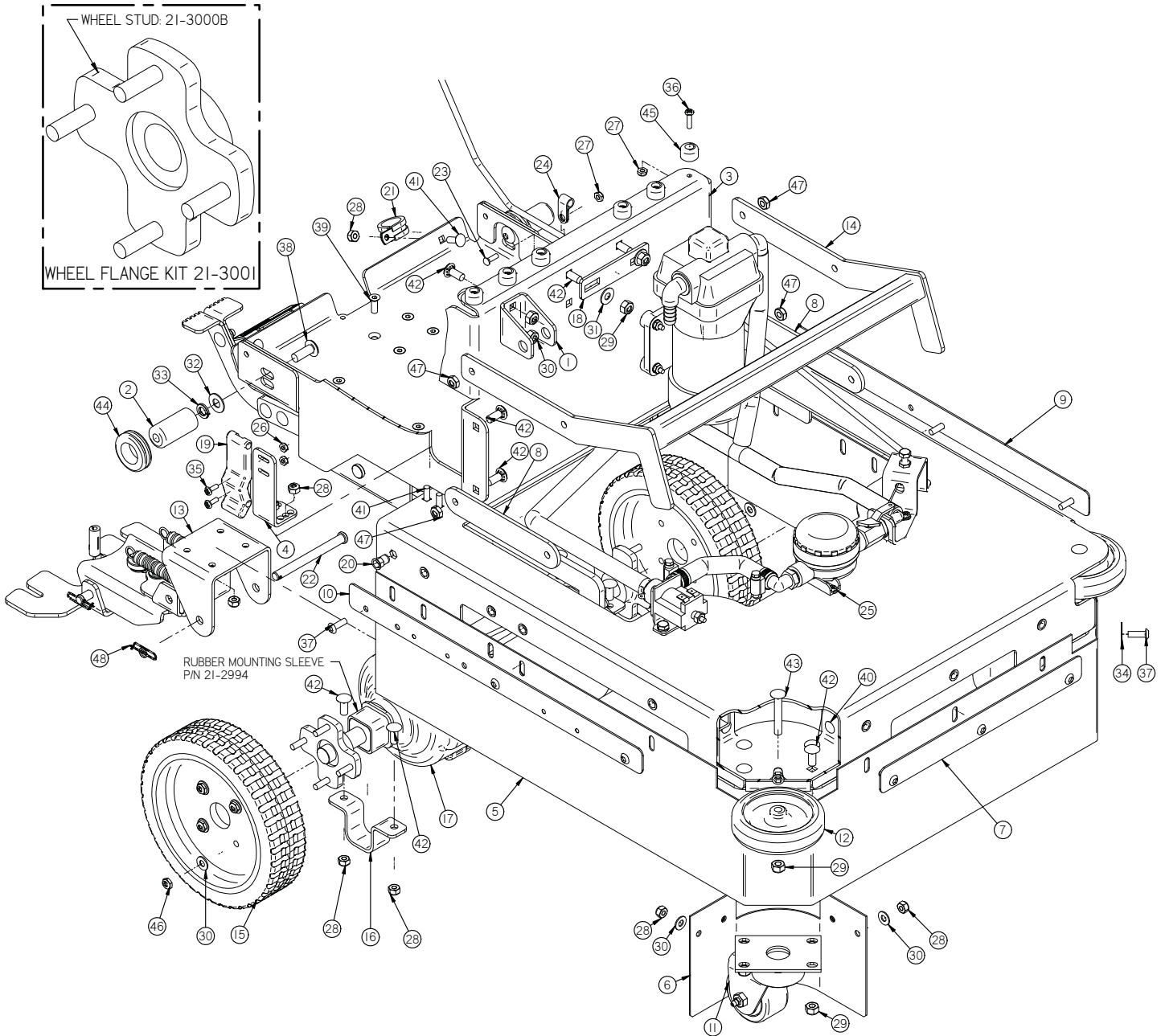

Item	Part No.	Part Description	Qty.	Item	Part No.	Part Description	Qty.
1	150-1006	LIFTING BRACKET	1	25	H-02309	HCN #10-32, LG CRIMP	4
2	150-1060	BOSS	2	26	H-70856	NYLOK #8-32 SS	4
3	150-1103	20 INCH MAIN FRAME TRACTION DRIVE	1	27	H-70858	NYLOK #10-32 SS	7
4	150-1124	LATCH BRACKET	2	28	H-70860	NYLOK 1/4" - 20 SS	24
5	150-1157	MAIN FRAME CURTAIN (20" TRACI)	1	29	H-70861	NYLOK 5/16" - 18 SS	14
6	150-1165	CASTER CURTAIN	2	30	H-71013	FW 1/4 ID X 5/8 OD SS	18
7	150-1169	MAIN FRAME FRONT CURTAIN BAND	1	31	H-71015	FW 5/16 ID X 3/4 OD SS	2
8	150-1240	LATERAL ARM	2	32	H-71017	FW 3/8 ID X 7/8 OD SS	2
9	150-1368	FRAME SIDE CURTAIN BAND (20" LHI)	1	33	H-71067	LW 3/8" SS	2
10	150-1468	FRAME SIDE CURTAIN BAND (20" RHI)	1	34	H-71212	FNW 1/4 ID X 1.0 OD SS	2
11	150-3030	CASTER	2	35	H-72398	PPH #8-32 X 1/2" S/S	4
12	150-7600	4" SIDE WHEEL (GREY)	2	36	H-72534	PPH #10-32 X 3/4" S/S	6
13	150-7611	SQUEEGEE DRAG BRACKET	1	37	H-73754	BHSCS 1/4 - 20 X 3/4" SS	11
14	150-9586	LATERAL ARM	1	38	H-73817	BHSCS 3/8" - 16 X 1-1/2" SS	2
15	170-6180	8" WHEEL COUNTRY TREAD	2	39	H-73882	FHSCS 1/4 - 20 X 3/4" S/S	6
16	21-1010	AXLE MOUNT	2	40	H-74418	CB 1/4" - 20 X 5/8" S/S	8
17	21-3009	TRANSAXLE	1	41	H-74419	CB 1/4" - 20 X .75" SS	5
18	253-1040	TANK STRAP SUPPORT	1	42	H-74429	CB 5/16" - 18 X 3/4" SS	20
19	4-124	LATCH	2	43	H-74433	CB 5/16" - 18 X 2" SS	2
20	H-00918	HCN 1/4"-20 LG	17	44	H-9307K74	GROMMET, 1" ID X 1-3/4" OD BUNA-N	2
21	H-0127296	1.0" LOOP CLAMP	1	45	H-9540	RUBBER BUMPER, 25/32"	6
22	H-0156759	3/8" X 4" CLEVIS PIN (ZINKI)	1	46	H-NJ04C	JNYL 1/4" - 20 SS	8
23	H-0172519	CB #10-32 X 5/8" SS	1	47	H-NJ05C	JNYL 5/16" - 18 SS	4
24	H-02239	3/8" VINYL LOOP CLAMP	1	48	H-RUE14	3/8" RUE RING COTTER	1

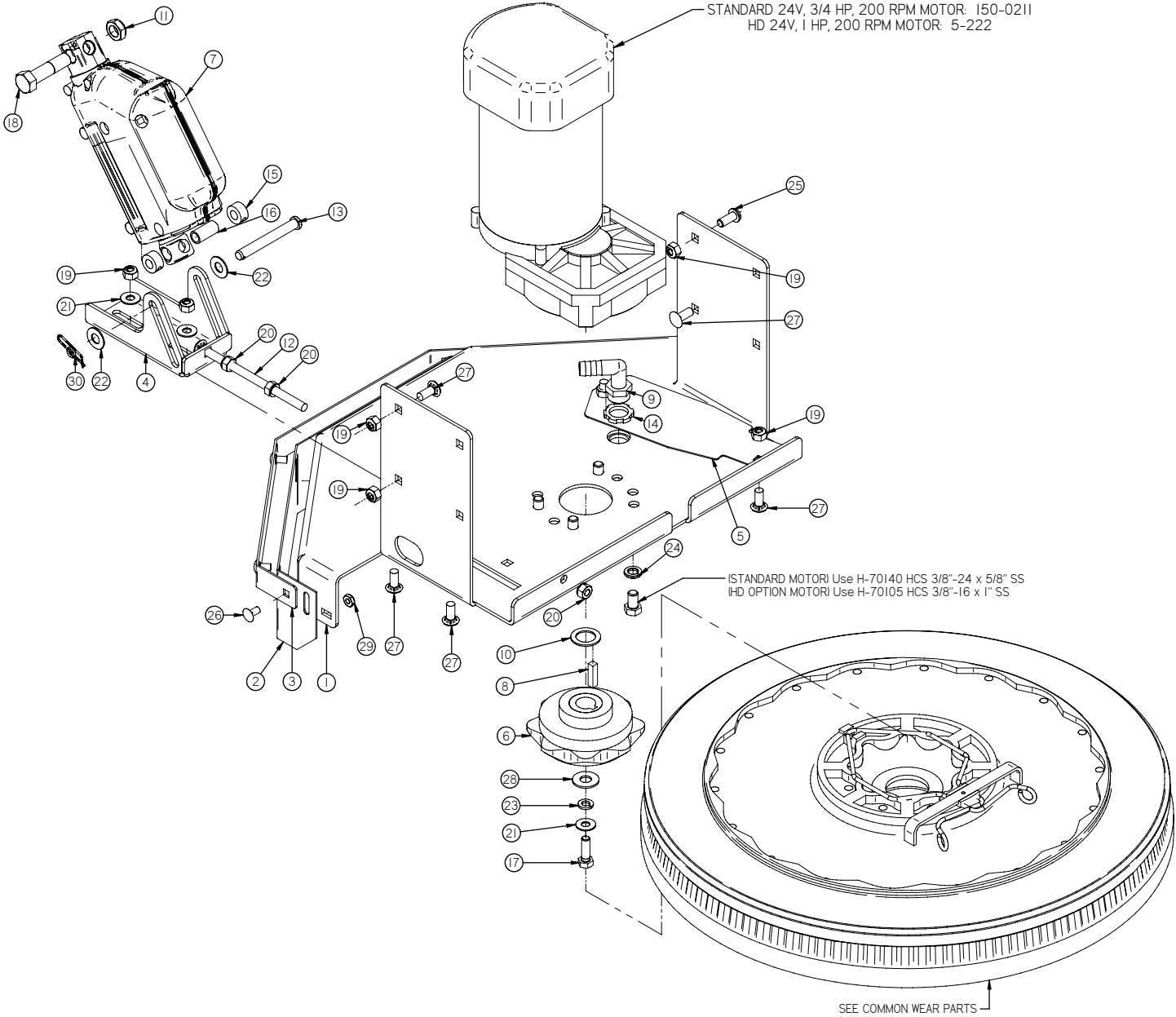

Item	Part No.	Part Description	Qty.	Item	Part No.	Part Description	Qty.
1	150-1120	DISK DECK PLATFORM, 20"	1	16	H-63917	SLEEVE, .50 OD X .375 ID X 1.0 LG	1
2	150-1172	DISK DECK CURTAIN, 20"	1	17	H-70055	HCS 5/16"- .18 X 1" SS	1
3	150-1176	DISK DECK CURTAIN BAND, 20"	1	18	H-70211	HCS 1/2"-13 X 2.0" SS	1
4	150-9003	LIFTING BRACKET	1	19	H-70861	NYLON 5/16" - 18 SS	8
5	170-1030	DISK DECK COVER PLATE	1	20	H-70926	KN 15/16-18 S/S	3
6	21-5000	BRUSH DRIVER	1	21	H-71015	FW 5/16 ID X 3/4 OD SS	3
7	253-2240	2" STROKE 24V ACTUATOR 450 LB LOAD	1	22	H-71017	FW 3/8 ID X 7/8 OD SS	2
8	5-431	1/4" X 1" KEY	1	23	H-71065	LW 5/16" SS	1
9	5-447	1/2 NPT X 1/2" BARB ELBOW	1	24	H-71067	LW 3/8" SS	4
10	H-00222	FW 3/4" ID X 1 1/8" OD X 3/32" SS	1	25	H-73779	BHSCS 5/16-18 X 3/4"	1
11	H-0129159	JNYL, 1/2"-13, 18-8 SS	1	26	H-74417	CB 1/4" - 20 X .5" SS	6
12	H-0144098	CB 5/16"- .18 X 5-1/2" ZINK	1	27	H-74429	CB 5/16"- .18 X 3/4" SS	7
13	H-0156756	CLEVIS PIN 3/8" x 3.00"	1	28	H-99001	FW 3/8" SS	1
14	H-07005	1/2" NPT LOCKNUT	2	29	H-NJ04C	JNYL 1/4" - 20 SS	6
15	H-33372	SHAFT COLLAR, 3/8" ID	2	30	H-RUE14	3/8" RUE RING COTTER	1

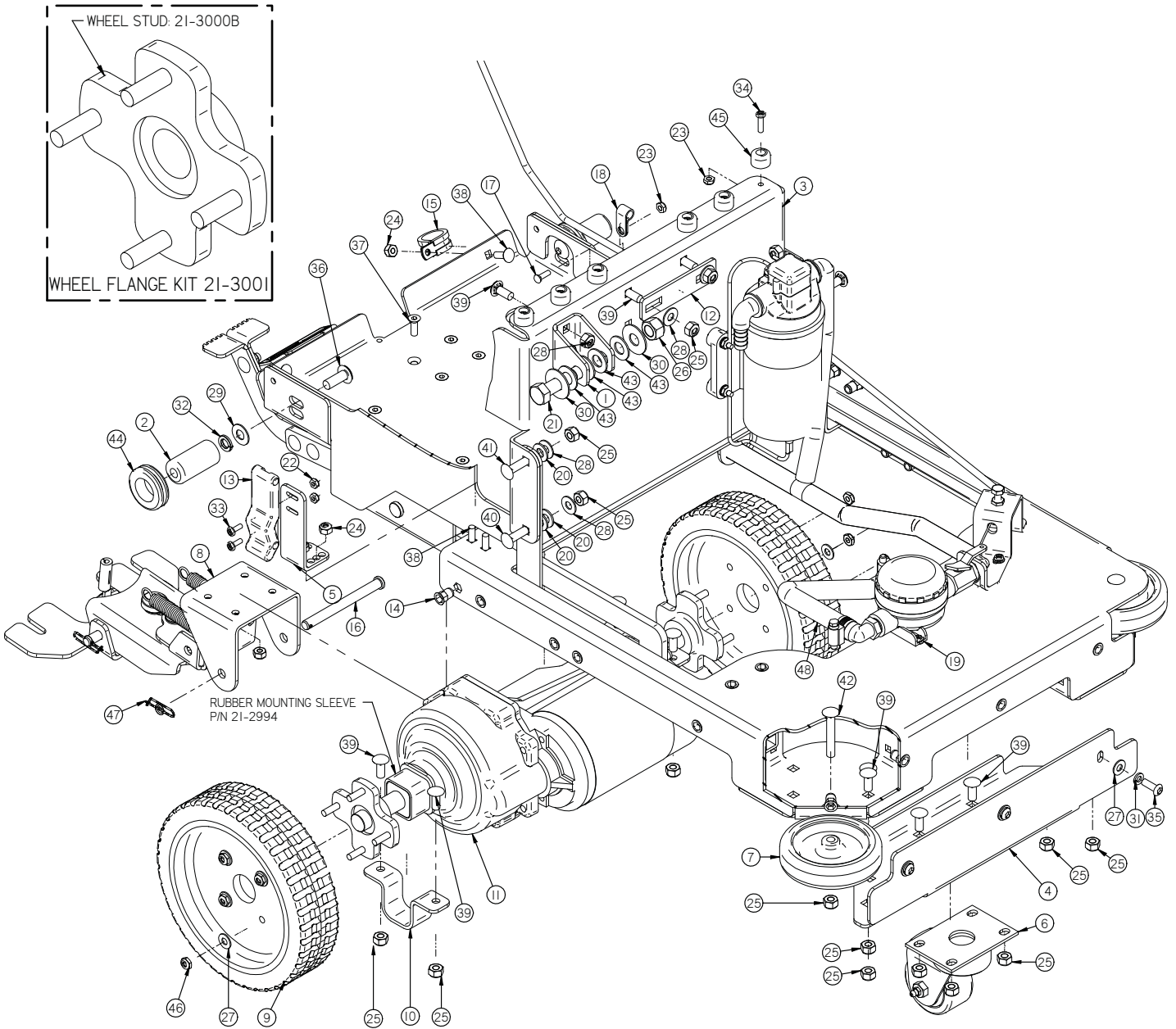

Item	Part No.	Part Description	Qty.	Item	Part No.	Part Description	Qty.
1	150-1006	LIFTING BRACKET	1	25	H-70861	NYLOK 5/16" - 18 SS	22
2	150-1060	BOSS	2	26	H-70864	NYLOK 1/2"-13 SS	1
3	150-1102	17 INCH MAIN FRAME TRACTION DRIVE	1	27	H-71013	FW 1/4 ID X 5/8 OD SS	13
4	150-1104	SINGLE CASTER MOUNT	1	28	H-71015	FW 5/16 ID X 3/4 OD SS	6
5	150-1124	LATCH BRACKET	2	29	H-71017	FW 3/8 ID X 7/8 OD SS	2
6	150-3030	CASTER	1	30	H-71021	FW 1/2 ID X 1-1/4 OD SS	2
7	150-7600	4" SIDE WHEEL (GREY)	2	31	H-71063	LW 1/4" SS	3
8	150-7611	SQUEEGEE DRAG BRACKET	1	32	H-71067	LW 3/8" SS	2
9	170-6180	8" WHEEL COUNTRY TREAD	2	33	H-72398	PPH #8-32 X 1/2" S/S	4
10	21-1010	AXLE MOUNT	2	34	H-72534	PPH #10-32 X 3/4" S/S	6
11	21-3009	TRANSAXLE	1	35	H-73754	BHSCS 1/4 - 20 X 3/4" SS	3
12	253-1040	TANK STRAP SUPPORT	1	36	H-73817	BHSCS 3/8"- 16 X 1-1/2" SS	2
13	4-124	LATCH	2	37	H-73882	FHSCS 1/4- 20 X 3/4" S/S	6
14	H-00918	HCN 1/4"-20 LG	17	38	H-74419	CB 1/4"- 20 X .75" SS	5
15	H-0127296	1.0" LOOP CLAMP	1	39	H-74429	CB 5/16"- 18 X 3/4" SS	16
16	H-0156759	3/8" X 4" CLEVIS PIN (ZINK)	1	40	H-74430	CB 5/16"- 18 X 1" SS	2
17	H-0172519	CB #10-32 X 5/8" SS	1	41	H-74432	CB 5/16"- 18 X 1-1/2" SS	2
18	H-02239	3/8" VINYL LOOP CLAMP	1	42	H-74433	CB 5/16"- 18 X 2" SS	2
19	H-02309	HCN #10-32 LG CRIMP	4	43	H-76065	FW 1/2" NYLON	4
20	H-4440024	FW 3/8" X 3/4" NYLON	6	44	H-9307K74	GROMMET, 1" ID X 1-3/4" OD BUNA-N	2
21	H-70213	HCS 1/2"-13 X 2-1/2" SS	1	45	H-9540	RUBBER BUMPER, 25/32"	6
22	H-70856	NYLOK #8-32 SS	4	46	H-NJ04C	JNYL 1/4" - 20 SS	8
23	H-70858	NYLOK #10-32 SS	7	47	H-RUE14	3/8" RUE RING COTTER	1
24	H-70860	NYLOK 1/4"- 20 SS	12	48	T-050R1000	ELBOW TO VALVE TUBE	1

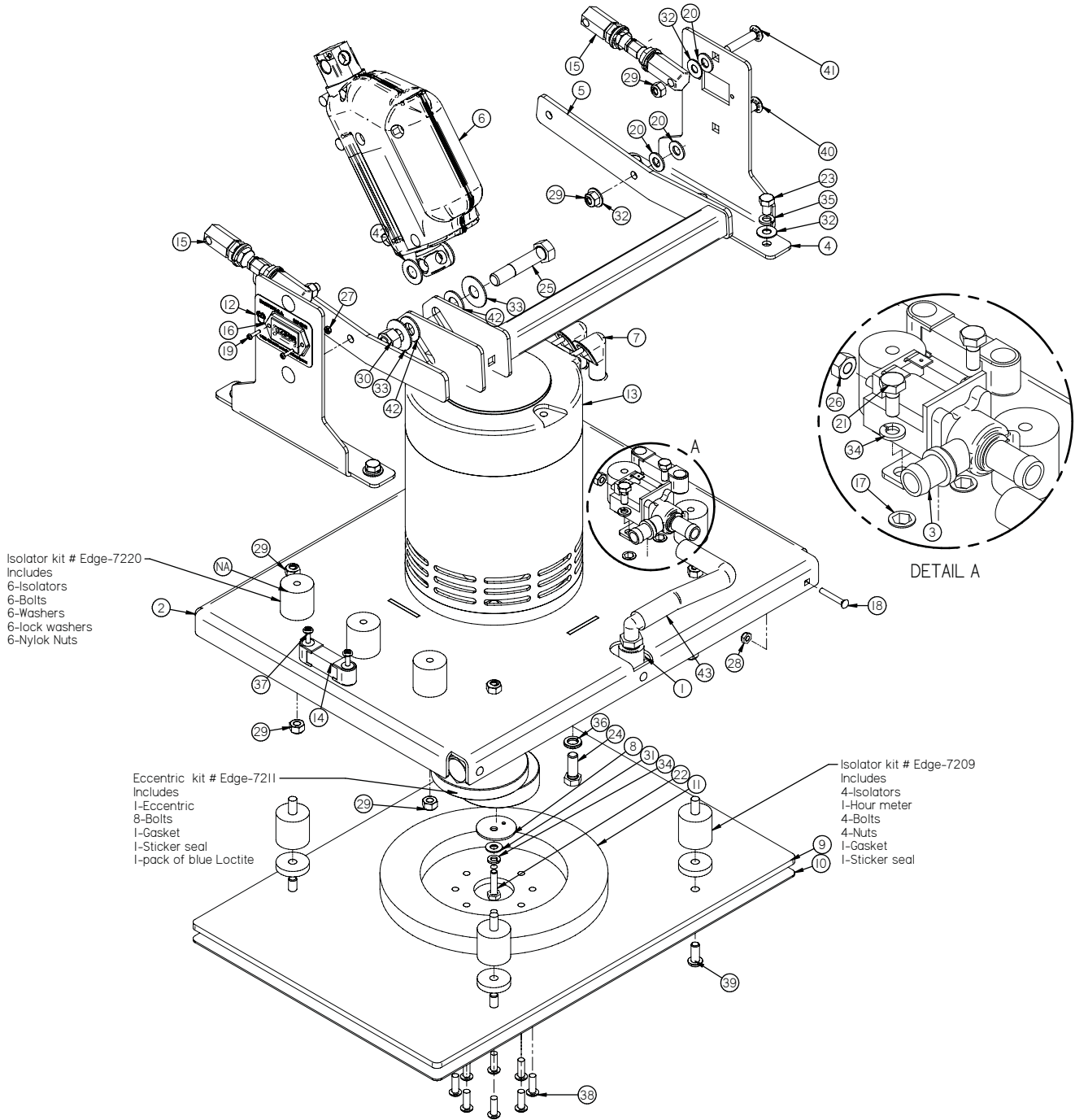

Item	Part No.	Part Description	Qty.	Item	Part No.	Part Description	Qty.
1	150-3015	20 INCH EDGE SOL. FEED TUBE	1	23	H-70051	HCS 5/16"- 18 X 1/2"	6
2	150-4020	20 INCH MICRO EDGE DECK	1	24	H-70105	HCS 3/8"- 16 X 1" SS	4
3	150-4500	ADJUSTABLE SOLUTION FLOW VALVE	1	25	H-70213	HCS 1/2"-13 X 2-1/2" SS	1
4	150-9070	MICRO EDGE DECK LIFTING BRACKET	2	26	H-70730	HN 1/4"- 28 SS	1
5	150-9587	MICRO EDGE LIFT ARM	1	27	H-70854	NYLOK #4-40 SS	2
6	253-2240	2" STROKE 24V ACTUATOR 450 LB LOAD	1	28	H-70858	NYLOK #10-32 SS	3
7	290-2780	TERMINAL BOOT, BLACK	2	29	H-70861	NYLOK 5/16"- 18 SS	12
8	300-01030Z	CRUSH WASHER	1	30	H-70864	NYLOK 1/2"-13 SS	1
9	300-01034Z	20 INCH ALUMINUM PAD DRIVER	1	31	H-71013	FW 1/4 ID X 5/8 OD SS	1
10	300-01037Z	GRIP FACE	1	32	H-71015	FW 5/16 ID X 3/4 OD SS	10
11	300-1070	3/4" BEARING GASKET	1	33	H-71021	FW 1/2 ID X 1-1/4 OD SS	2
12	300-2013	ISOLATOR STICKER	1	34	H-71063	LW 1/4" SS	3
13	300-2700	24V,1.2HP,2900 RPM	1	35	H-71065	LW 5/16" SS	6
14	300-4030	LEVEL	2	36	H-71067	LW 3/8" SS	4
15	300-8421	ADJUSTABLE LATERAL ARM	2	37	H-72398	PPH #8-32 X 1/2" S/S	4
16	8-262	HOUR METER	1	38	H-73754	BHSCS 1/4 - 20 X 3/4" SS	8
17	H-00918	HCN 1/4"-20 LG	2	39	H-73779	BHSCS 5/16-18 X 3/4"	4
18	H-0172522	CB #10-32 X 1-1/4" SS	3	40	H-74430	CB 5/16"- 18 X 1" SS	2
19	H-28679	PPH #4-40 X 1/2"	2	41	H-74432	CB 5/16"- 18 X 1-1/2" SS	2
20	H-4440024	FW 3/8" X 3/4" NYLON	6	42	H-76065	FW 1/2" NYLON	4
21	H-70002	HCS 1/4"- 20 X 5/8" SS	2	43	T-050R0700	VALVE TO ELBOW	1
22	H-70005	HCS 1/4"- 20 X 1" SS	1				

### 130 AH TROJANS 170-2109 USE CHARGER 150-2440

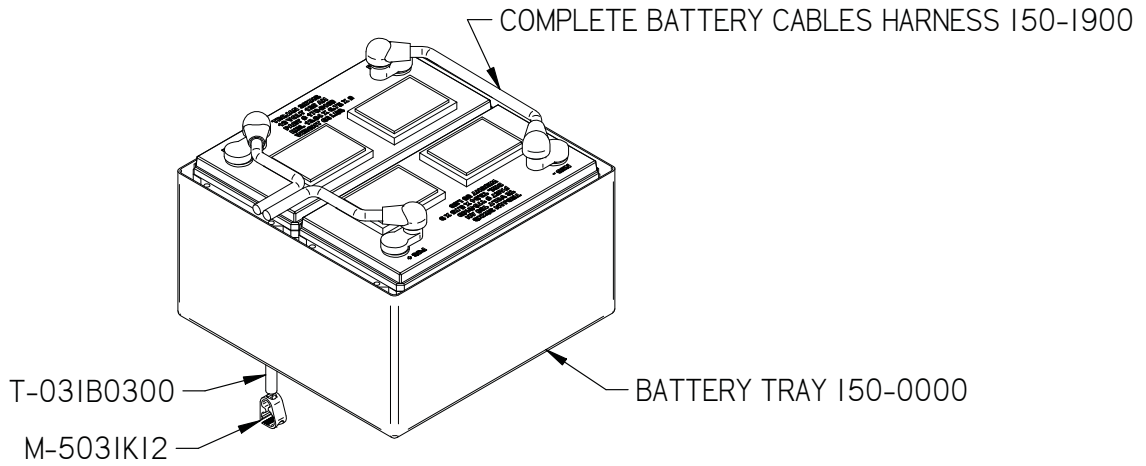

### 85 AH CROWNS 150-2110 USE CHARGER 150-2440

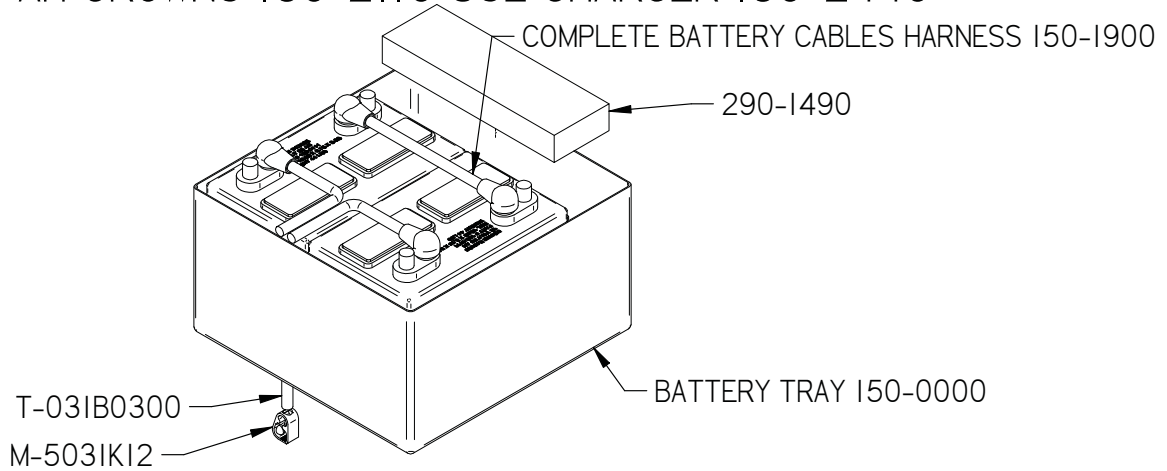

### 85 AH AGM 150-2120 USE CHARGER 170-2440

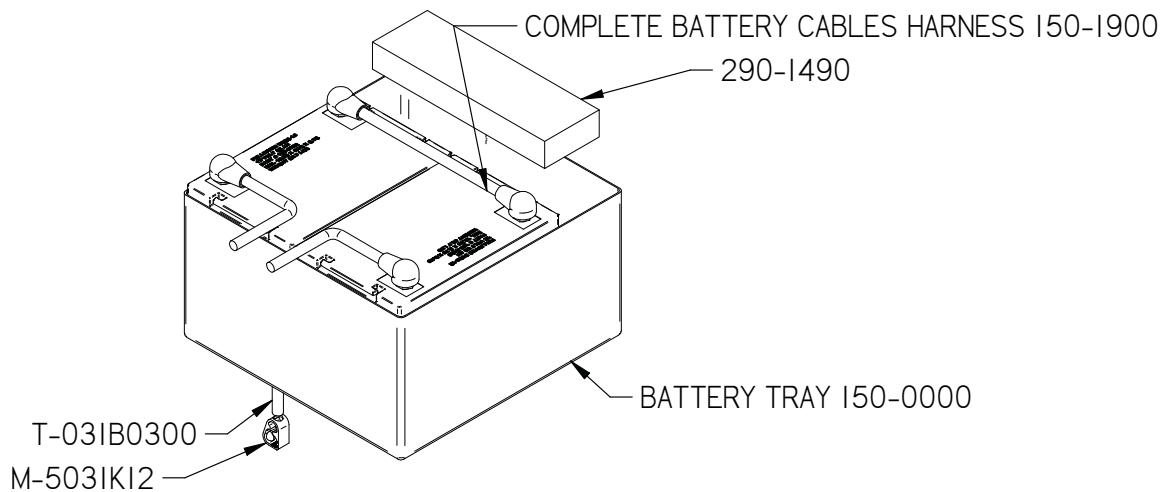



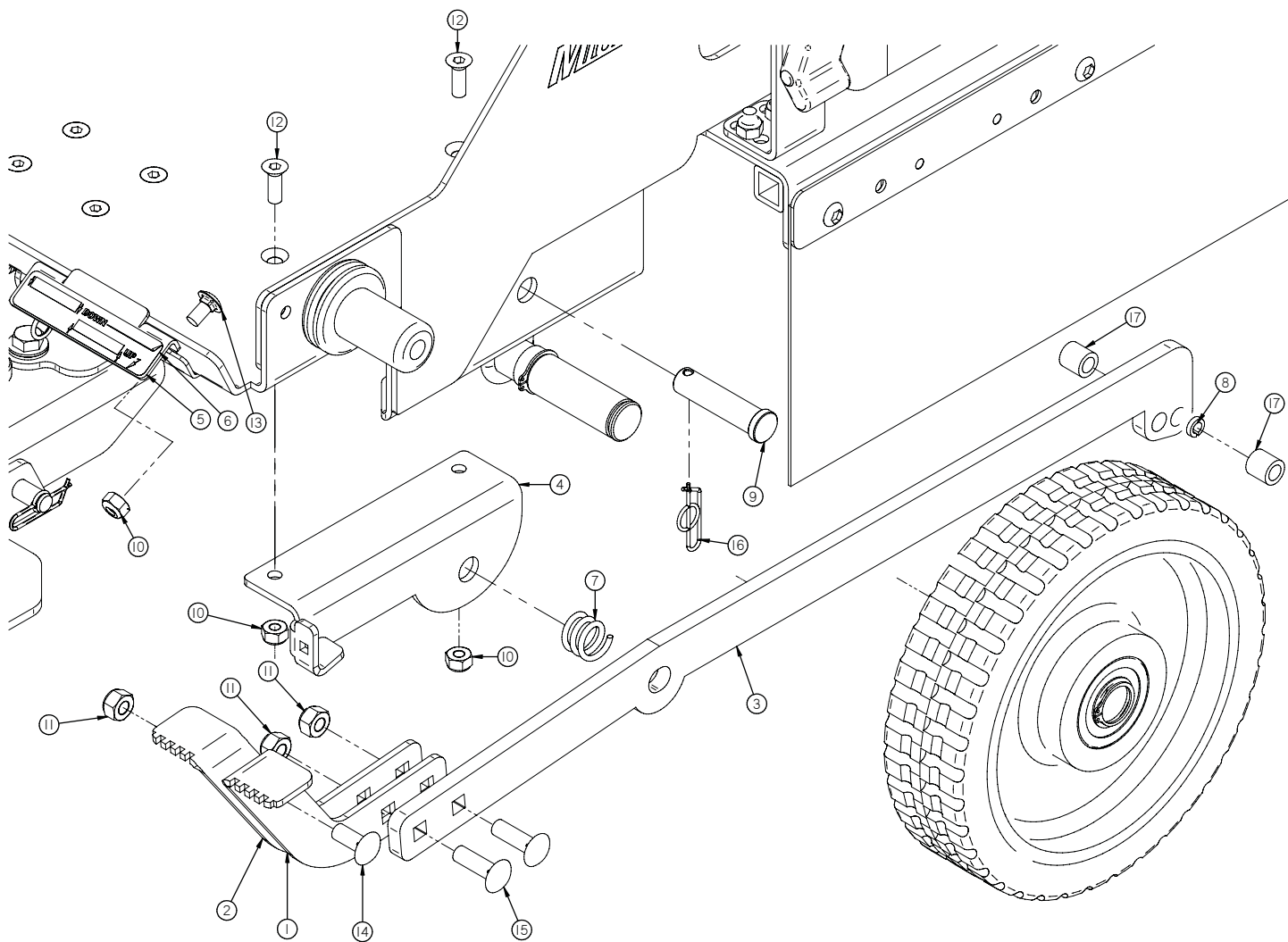

Item	Part No.	Part Description	Qty.
1	150-4508	RIGHT DECK LIFT ARM	1
2	150-4509	LEFT DECK LIFT ARM	1
3	150-4510	MAIN DECK LFT ARM	1
4	150-4511	LIFT ARM PIVOT LOCK	1
5	150-4512	STICKER BRACKET	1
6	150-4513	FOOT PEDAL STICKER	1
7	150-7240	SPRING, 1/2" ID X 5/8" LG	1
8	H-00105	3/8" X 1 1/4" SPRING PIN	1
9	H-0156771	CLEVIS PIN, 1/2" OD X 2" LG	1
10	H-70860	NYLOK 1/4" - 20 SS	3
11	H-70861	NYLOK 5/16" - 18 SS	3
12	H-73882	FHSCS 1/4" - 20 X 3/4" S/S	2
13	H-74417	CB 1/4" - 20 X 5" SS	1
14	H-74429	CB 5/16" - 18 X 3/4" SS	1
15	H-74430	CB 5/16" - 18 X 1" SS	2
16	H-RUE22	1/2" RUE RING COTTER	1
17	T-031C0050	5/16" X 1/2" CLEAR TUBING	2



# 16 Solution Flow Filter

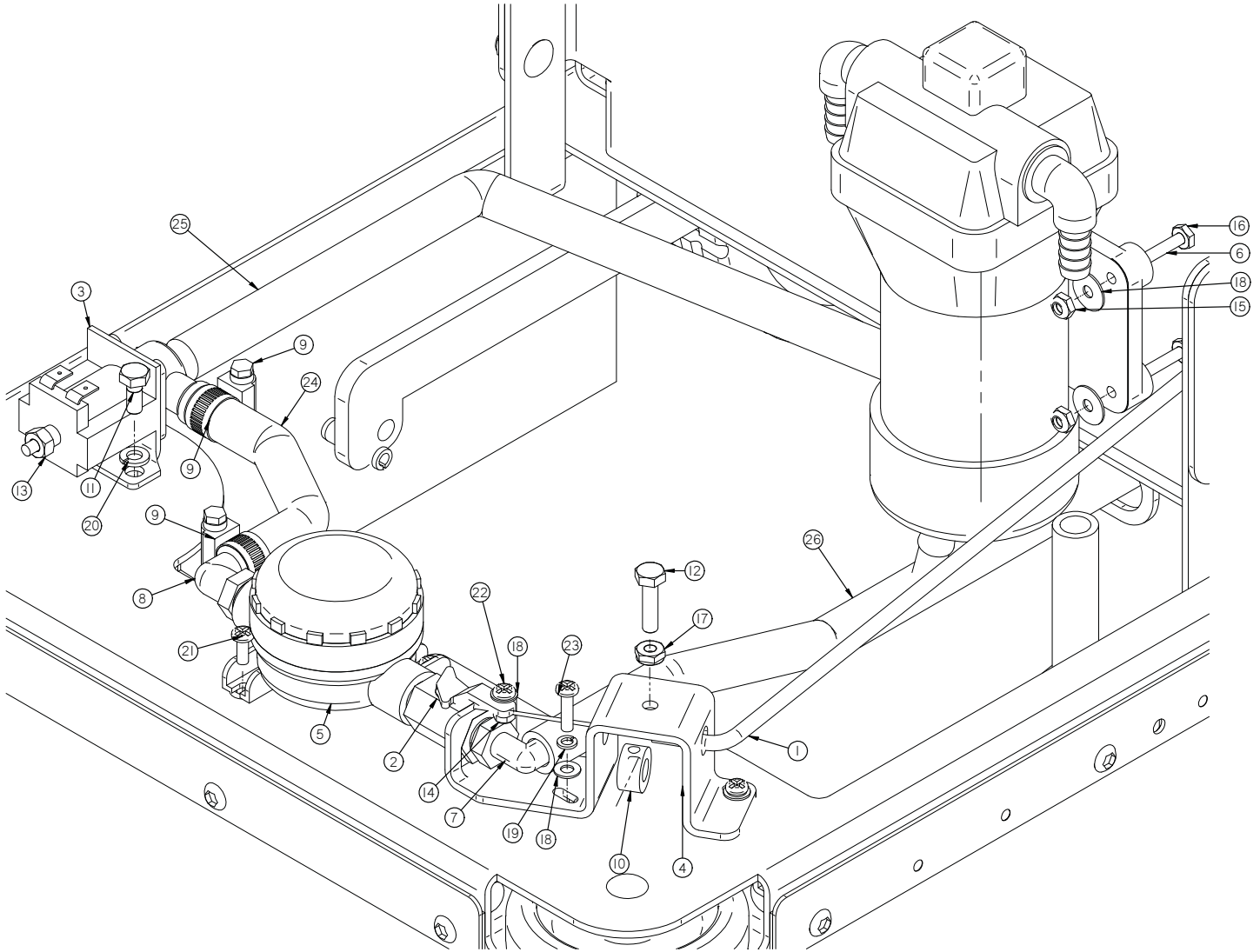

Item	Part No.	Part Description	Qty.
1	150-2014	SOLUTION FLOW CABLE	1
2	150-4158	BALL VALVE, 3/8"	1
3	150-4500	ADJUSTABLE SOLUTION FLOW VALVE	1
4	150-9130	VALVE CABLE GUIDE	1
5	370-9130	INLINE FILTER	1
6	H-0172522	CB #10-32 X 1-1/4" SS	4
7	H-04762	ELBOW, 90 DEG X 3/8" MNPT X 3/8" BARB, NYLON	1
8	H-04764	ELBOW, 90 DEG X 3/8" MNPT X 1/2" BARB, NYLON	1
9	H-081	HOSE CLAMP, 5/8"- 1-1/2" S/S	2
10	H-33372	SHAFT COLLAR, 3/8" ID	1
11	H-70002	HCS 1/4"-20 X 5/8" SS	2
12	H-70005	HCS 1/4"- 20 X 1" SS	1
13	H-70730	HN 1/4"- 28 SS	1
14	H-70855	NYLOK #6-32 SS	1
15	H-70858	NYLOK #10-32 SS	4
16	H-70923	KN #10-32 SS	4
17	H-70925	KN 1/4-20 S/S	1
18	H-71009	FW #10 SS	7
19	H-71059	LW #10, SS	2
20	H-71063	LW 1/4" SS	2
21	H-72515	PPH #10-32 X 1/2" S/S	2
22	H-72516	PPH #6-32 X 1/2" SS	1
23	H-72534	PPH #10-32 X 3/4" S/S	2
24	T-050R0550	1/2" ID HOSE X 5-1/2 LG	1
25	T-050R1700	VALVE TO DECK	1
26	T-375R1700	WYE TO VALVE	1

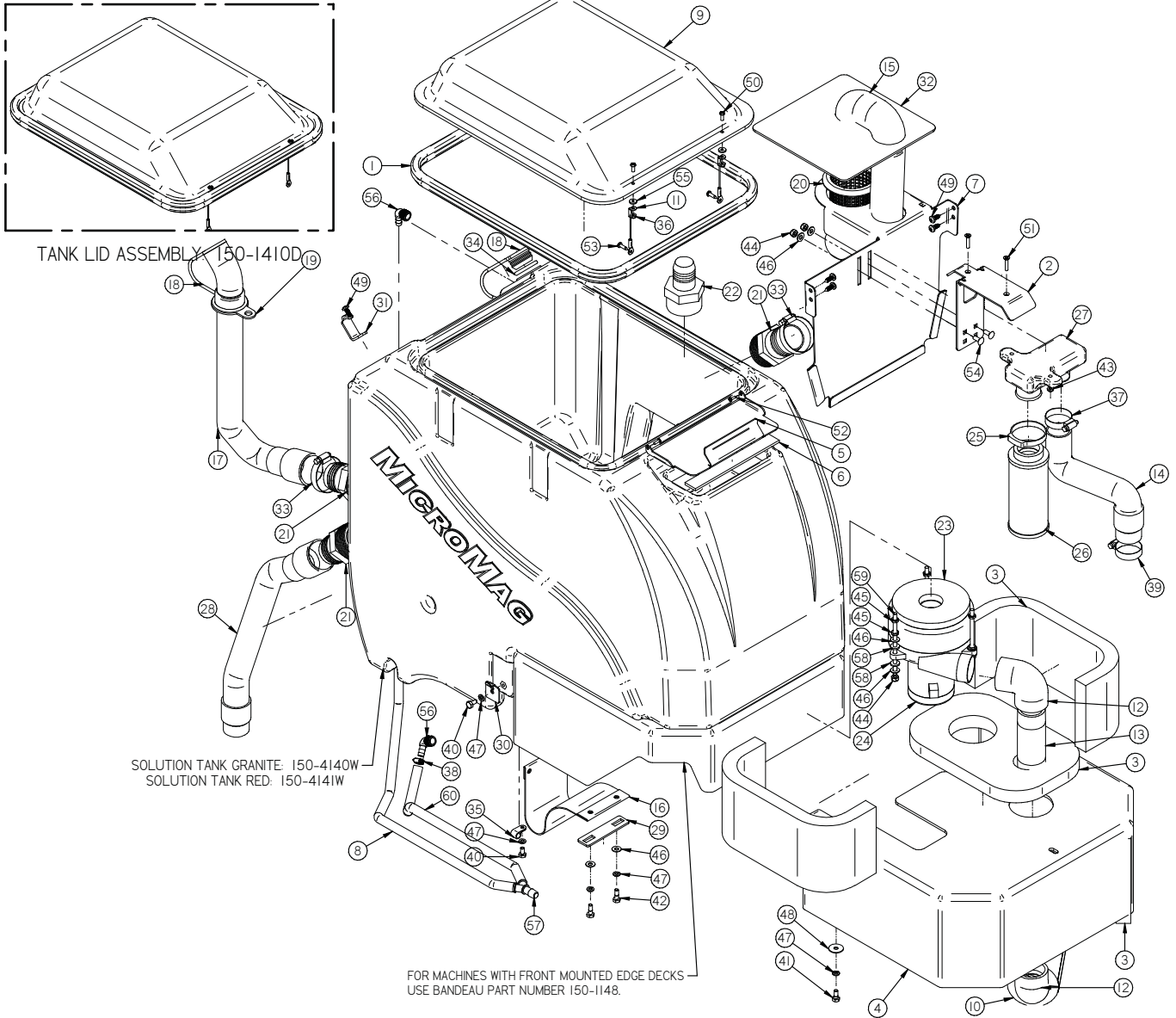

SOLUTION TANK GRANITE: 150-4140W  
 SOLUTION TANK RED: 150-4141W

FOR MACHINES WITH FRONT MOUNTED EDGE DECKS  
 USE BANDEAU PART NUMBER 150-1148.

Item	Part No.	Part Description	Qty.	Item	Part No.	Part Description	Qty.
1	150-1075	PUSH-ON RUBBER GASKET	1	31	253-9491	HOOK	1
2	150-1122	BALL, FLOAT HOLDER	1	32	370-1129	TANK BACK SPLASH	1
3	150-1137	VAC MOTOR INSULATION	1	33	5-719	CLAMP 1/916 - 2 1/2" SS	2
4	150-1147	BANDEAU COVER (DISK), PLASTIC	1	34	5-8290	O-RING, #324, 1.35" X 1.77" X .210" BUNA-N	1
5	150-1180	SOLUTION FILL LID	1	35	H-0127288	#6 3/8" RUBBER LOOP CLAMP	1
6	150-1190	SEAL	1	36	H-0129155	JNYL #10-32, 18-8 S/S	2
7	150-1230	BAFFLE	1	37	H-0427612	CLAMP 3/4"- 1-3/4" SS	1
8	150-1370	SIGHT TUBE	1	38	H-62002	HOSE CLAMP, #4 S/S	1
9	150-1410	VAC FORMED SMOKED COVER	1	39	H-62044	CLAMP 1.0" - 2.0" SS	1
10	150-2502	VACUUM FAN MUFFLER, 8" LG	2	40	H-70001	HCS 1/4"-20 X 1/2 SS"	3
11	150-4060	LANYARD	2	41	H-70002	HCS 1/4"-20 X 5/8" SS	3
12	150-7291	EXHAUST ELBOW	2	42	H-70003	HCS 1/4"-20 X 3/4" SS	2
13	150-7292	1-1/2" X 5" NIPPLE	1	43	H-70858	NYLOK #10-32 SS	2
14	170-0120	1-1/2" DIA. INNER VAC HOSE	1	44	H-70860	NYLOK 1/4"- 20 SS	5
15	170-0121	INNER SQUEEGEE HOSE	1	45	H-70925	KN 1/4-20 S/S	6
16	170-1045	TANK STRAP, 22" LG X 4" WIDE	1	46	H-71013	FW 1/4 ID X 5/8 OD SS	10
17	170-7210	1-1/2 INCH DIA. COMPLETE DRAIN HOSE	1	47	H-71063	LW 1/4" SS	8
18	170-7211	HOSE CAP	2	48	H-71212	FNW 1/4 ID X 1.0 OD SS	3
19	170-7212	STRAP, HOSE RETAINER, 2"	1	49	H-71893	1/4 X 3/4 SELF TAPPING SCREW	5
20	170-8911	SCREEN STRAINER, 4-1/4" LG	1	50	H-72515	PPH #10-32 X 1/2" S/S	2
21	190-1210	2.0" MNPT X 2.0" BARB, PVC	3	51	H-72685	FHP 10-32 X 1" SS	2
22	190-1215	2.0" MNPT X 1.50" BARB, PVC	1	52	H-72904	PPH SMS #6 X 1/2" SS	2
23	190-3002	VAC MOTOR GASKET	1	53	H-72916	PPH SMS #8 X 3/4" SS	2
24	190-5250	VAC MOTOR, 3/4 HP, TANGENTIAL	1	54	H-74418	CB 1/4"- 20 X 5/8" S/S	2
25	21-4028	SNAP GRIP CLAMP	1	55	H-90133	170 ID X .50 OD X .093 TH NEOPRENE WASHER	2
26	21-4085	VAC SCREEN	1	56	M-53525K18	ELBOW, 3/8" MNPT X 3/8" BARB, BRASS	3
27	21-7060	VAC BOX	1	57	M-5463K116	WYE, 3/8", NYLON	1
28	253-0111	SQUEEGEE HOSE	1	58	M-90130A029	.25" NEOPRENE WASHER	6
29	253-1040	TANK STRAP SUPPORT	1	59	M-95412A562	FTS 1/4"- 20 X 5" SS	3
30	253-1240	CLIP	2	60	T-038R1700	ELBOW TO WYE	1

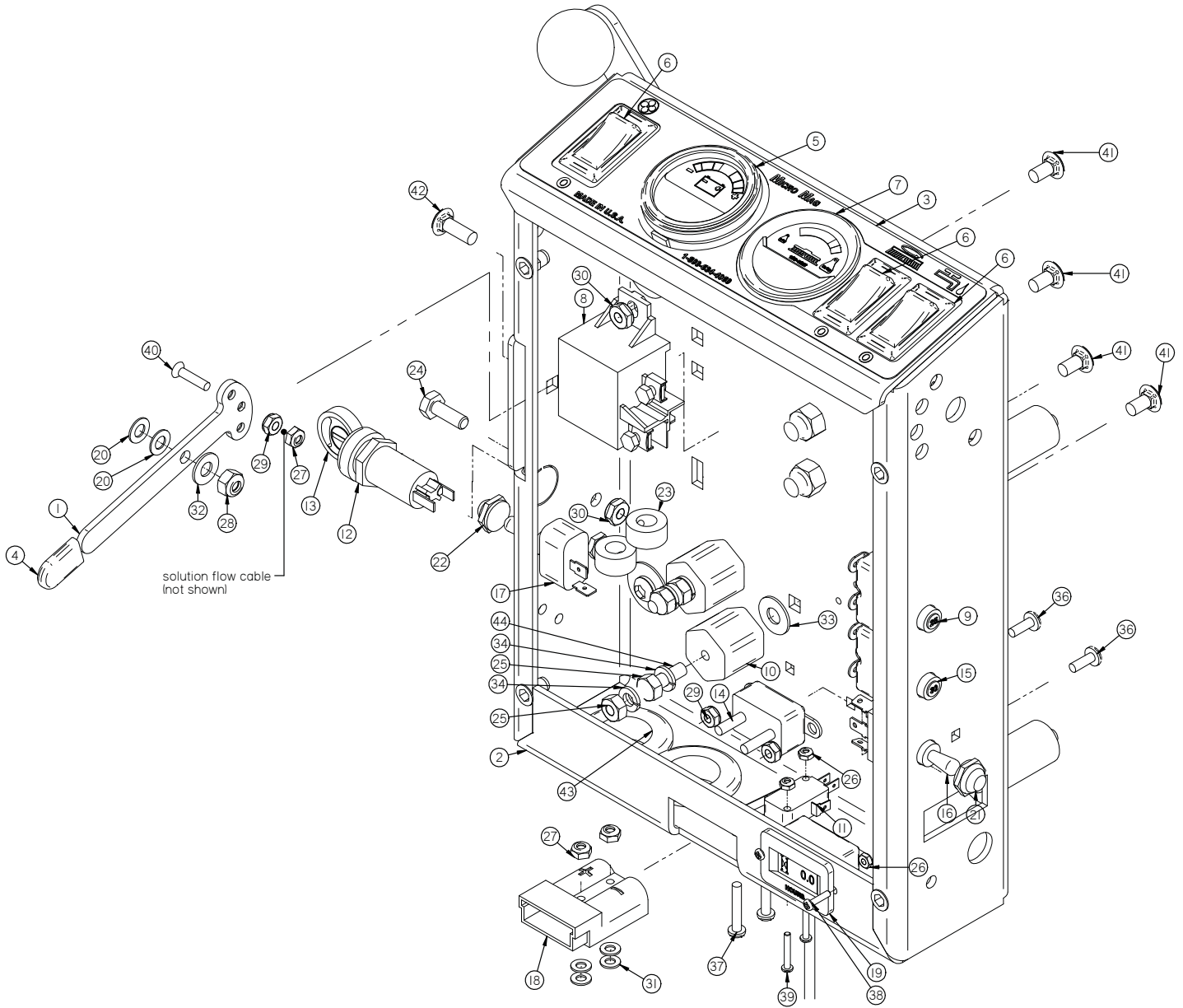

Item	Part No.	Part Description	Qty.	Item	Part No.	Part Description	Qty.
1	150-2003	VALVE LEVER	1	23	H-33372	SHAFT COLLAR, 3/8" ID	2
2	150-2010	CONTROL BOX	1	24	H-70003	HCS 1/4"-20 X 3/4" SS	2
3	150-2013	CONTROL PANEL STICKER	1	25	H-70710	HN 1/4"- 20 SS	4
4	150-4480	HANDLE GRIP (BLUE)	1	26	H-70854	NYLOK #4-40 SS	3
5	150-4855	METER, BATTERY, 24V	1	27	H-70856	NYLOK #8-32 SS	3
6	170-2340	SWITCH, ROCKER, DPDT, ON/ON	3	28	H-70860	NYLOK 1/4"- 20 SS	1
7	190-4852	BRUSH PRESSURE GAUGE, 40 AMP	1	29	H-70922	KN #8-32	3
8	190-8283	RELAY, 24V, 50 AMP	1	30	H-70925	KN 1/4-20 S/S	3
9	190-8370	FUSE RESETTABLE - 15A, 24V	1	31	H-71007	FW #8 SS	4
10	200-1011	SWITCHBOARD INSULATOR	2	32	H-71013	FW 1/4" ID X 5/8 OD SS	1
11	21-2230	MICRO SWITCH	1	33	H-71015	FW 5/16" ID X 3/4 OD SS	2
12	290-234	KEY SWITCH (WITH KEY)	1	34	H-71063	LW 1/4" SS	4
13	290-234A	KEY SET (REPLACE)	1	35	H-71212	FNW 1/4 ID X 1.0 OD SS	1
14	290-2815	CIR. BREAKER - 15A, 24V	1	36	H-72398	PPH #8-32 X 1/2" S/S	2
15	290-9609	FUSE, RESETTABLE, 30 AMP	1	37	H-72418	PPH #8-32 X 1" S/S	2
16	370-2830	SWITCH, TOGGLE, MOM/OFF/MOM (DPDT)	1	38	H-72486	PPH #4-40 X 1/2" S/S	2
17	370-8920	TOGGLE, ON-OFF SPST	1	39	H-72490	PPH #4-40 X 3/4" S/S	2
18	4-259	CONNECTOR, RED 50, HOUSING ONLY	1	40	H-72644	FHP #8-32 X 3/4"	1
19	8-262	HOUR METER	1	41	H-74417	CB 1/4"- 20 X .5" SS	4
20	H-00282	FW 1/4" NYLON	2	42	H-74419	CB 1/4"- 20 X .75" SS	1
21	H-11199	PROTECTIVE BOOT, TOGGLE SWITCH, (BLUE)	1	43	H-9307K74	GROMMET, 1" ID X 1-3/4" OD BUNA-N	2
22	H-11200	PROTECTIVE BOOT, TOGGLE SWITCH, (BLACK)	1	44	M-95412A544	STUD 1/4-20 X 1-1/4" SS	2

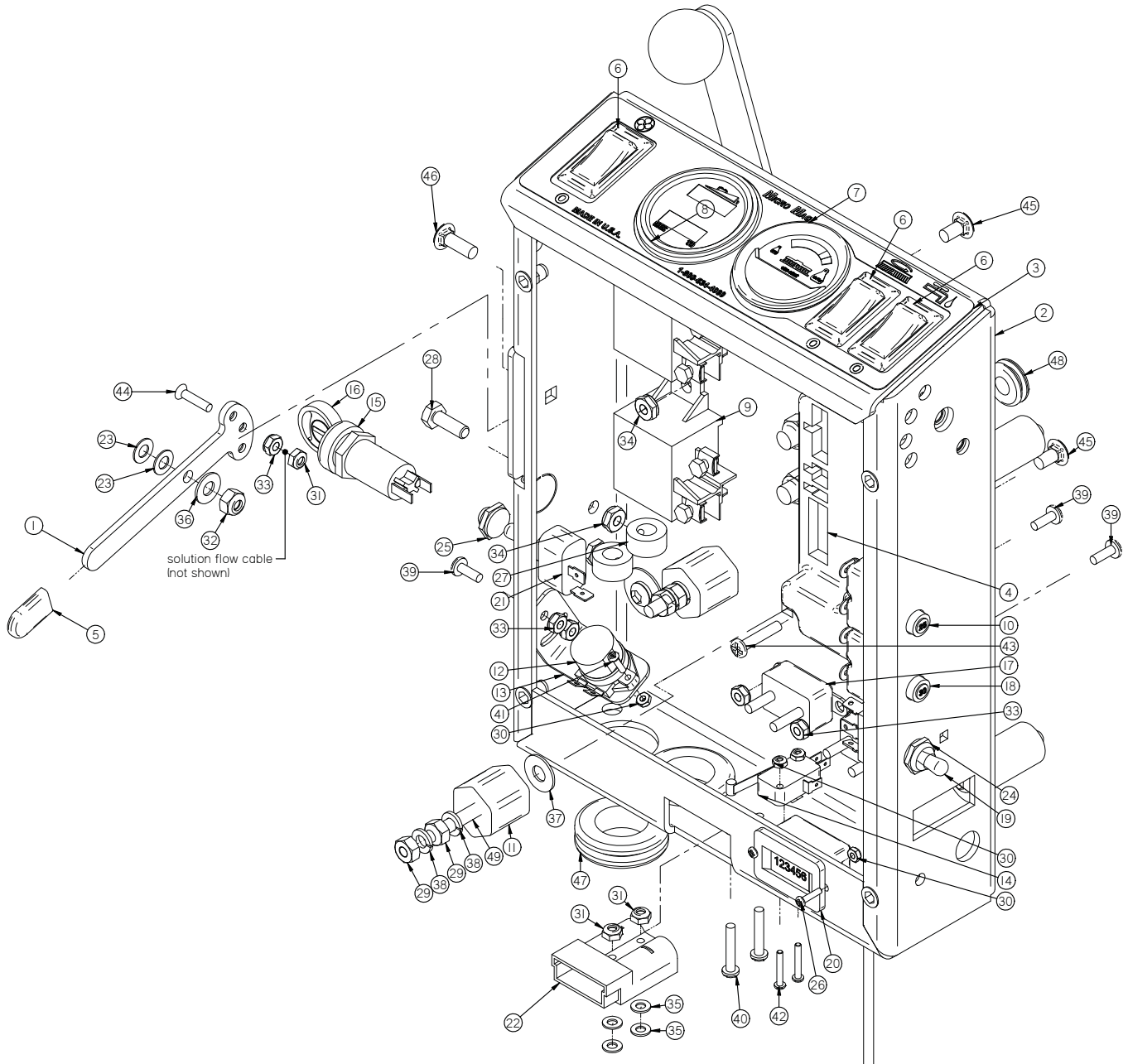

Item	Part No.	Part Description	Qty.	Item	Part No.	Part Description	Qty.
1	150-2003	VALVE LEVER	1	26	H-28679	PPH #4-40 X 1/2"	1
2	150-2010	CONTROL BOX	1	27	H-33372	SHAFT COLLAR, 3/8" ID	2
3	150-2013	CONTROL PANEL STICKER	1	28	H-70003	HCS 1/4"-20 X 3/4" SS	2
4	150-2899	IDRIVE 24V/36V, 70 AMP CONTROLLER	1	29	H-70710	HN 1/4"- 20 SS	4
5	150-4480	HANDLE GRIP (BLUE)	1	30	H-70854	NYLOK #4-40 SS	5
6	170-2340	SWITCH, ROCKER, DPDT, ON/ON	3	31	H-70856	NYLOK #8-32 SS	3
7	190-4852	BRUSH PRESSURE GAUGE, 40 AMP	1	32	H-70860	NYLOK 1/4"- 20 SS	1
8	190-4855	24V BATTERY AND HOUR METER	1	33	H-70922	KN #8-32	7
9	190-8283	RELAY, 24V, 50 AMP	1	34	H-70925	KN 1/4"-20 S/S	6
10	190-8370	FUSE RESETTABLE, 25 AMP	1	35	H-71007	FW #8 SS	4
11	200-1011	SWITCHBOARD INSULATOR	1	36	H-71013	FW 1/4 ID X 5/8 OD SS	1
12	200-1015	TILT SWITCH	1	37	H-71015	FW 5/16 ID X 3/4 OD SS	2
13	200-1016	TILT SWITCH BRACKET	1	38	H-71063	LW 1/4" SS	8
14	21-2230	MICRO SWITCH	1	39	H-72398	PPH #8-32 X 1/2" S/S	6
15	290-234	KEY SWITCH (WITH KEY)	1	40	H-72418	PPH #8-32 X 1" S/S	2
16	290-234A	KEY SET (REPLACE)	1	41	H-72486	PPH #4-40 X 1/2" S/S	2
17	290-2815	CIR. BREAKER - 15A, 24V	1	42	H-72490	PPH #4-40 X 3/4" S/S	2
18	290-9609	FUSE, RESETTABLE, 30 AMP	1	43	H-72536	PPH #10-32 X 1" S/S	2
19	370-2830	SWITCH, TOGGLE, MOM/OFF/MOM (DPDT)	1	44	H-72644	FHP #8-32 X 3/4"	1
20	370-8261	CHARGER COUNTER	1	45	H-74417	CB 1/4"- 20 X 5" SS	6
21	370-8920	TOGGLE, ON-OFF SPST	1	46	H-74419	CB 1/4"- 20 X 7.5" SS	1
22	4-259	CONNECTOR, RED 50, HOUSING ONLY	1	47	H-9307K74	GROMMET, 1" ID X 1-3/4" OD BUNA-N	2
23	H-00282	FW 1/4" NYLON	2	48	M-9307K23	GROMMET, 3/8 ID X 7/8 OD X 1/8 TH.	1
24	H-11199	PROTECTIVE BOOT, TOGGLE SWITCH, (BLUE)	1	49	M-95412A544	STUD 1/4"-20 X 1-1/4" SS	2
25	H-11200	PROTECTIVE BOOT, TOGGLE SWITCH, (BLACK)	1				

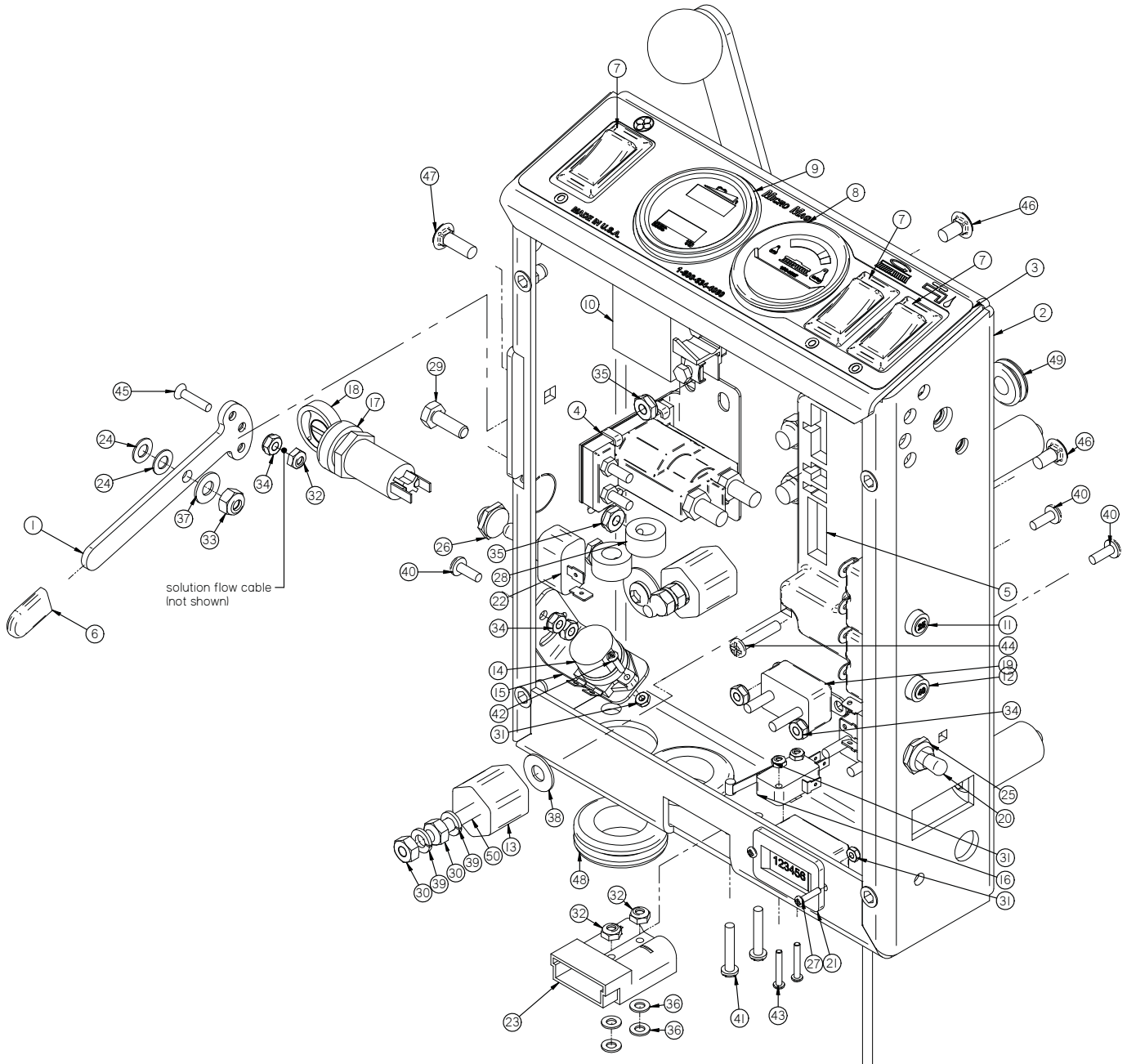

Item	Part No.	Part Description	Qty.	Item	Part No.	Part Description	Qty.
1	150-2003	VALVE LEVER	1	26	H-11200	PROTECTIVE BOOT, TOGGLE SWITCH, (BLACK)	1
2	150-2010	CONTROL BOX	1	27	H-28679	PPH #4-40 X 1/2"	1
3	150-2013	CONTROL PANEL STICKER	1	28	H-33372	SHAFT COLLAR, 3/8" ID	2
4	150-2331	RELAY, 24V, SMALL W/FLAT MTG PLATE	1	29	H-70003	HCS 1/4"-20 X 3/4" SS	2
5	150-2899	IDRIVE 24V/36V, 70 AMP CONTROLLER	1	30	H-70710	HN 1/4"-20 SS	4
6	150-4480	HANDLE GRIP (BLUE)	1	31	H-70854	NYLOK #4-40 SS	5
7	170-2340	SWITCH, ROCKER, DPDT, ON/ON	3	32	H-70856	NYLOK #8-32 SS	3
8	190-4852	BRUSH PRESSURE GAUGE, 40 AMP	1	33	H-70860	NYLOK 1/4"-20 SS	1
9	190-4855	24V BATTERY AND HOUR METER	1	34	H-70922	KN #8-32	7
10	190-8283	RELAY, 24V, 50 AMP	1	35	H-70925	KN 1/4"-20 S/S	6
11	190-8370	FUSE, RESETTABLE, 25 AMP	1	36	H-71007	FW #8 SS	4
12	190-9609	FUSE, RESETTABLE, 40 AMP	1	37	H-71013	FW 1/4 ID X 5/8 OD SS	1
13	200-1011	SWITCHBOARD INSULATOR	1	38	H-71015	FW 5/16 ID X 3/4 OD SS	2
14	200-1015	TILT SWITCH	1	39	H-71063	LW 1/4" SS	8
15	200-1016	TILT SWITCH BRACKET	1	40	H-72398	PPH #8-32 X 1/2" S/S	6
16	21-2230	MICRO SWITCH	1	41	H-72418	PPH #8-32 X 1" S/S	2
17	290-234	KEY SWITCH (WITH KEY)	1	42	H-72486	PPH #4-40 X 1/2" S/S	2
18	290-234A	KEY SET (REPLACE)	1	43	H-72490	PPH #4-40 X 3/4" S/S	2
19	290-2815	CIR. BREAKER - 15A, 24V	1	44	H-72536	PPH #10-32 X 1" S/S	2
20	370-2830	SWITCH, TOGGLE, MOM/OFF/MOM (DPDT)	1	45	H-72644	FHP #8-32 X 3/4"	1
21	370-8261	CHARGER COUNTER	1	46	H-74417	CB 1/4"-20 X .5" SS	6
22	370-8920	TOGGLE, ON-OFF SPST	1	47	H-74419	CB 1/4"-20 X .75" SS	1
23	4-259	CONNECTOR, RED 50, HOUSING ONLY	1	48	H-9307K74	GROMMET, 1" ID X 1-3/4" OD BUNA-N	2
24	H-00282	FW 1/4" NYLON	2	49	M-9307K23	GROMMET, 3/8 ID X 7/8 OD X 1/8 TH.	1
25	H-11199	PROTECTIVE BOOT, TOGGLE SWITCH, (BLUE)	1	50	M-95412A544	STUD 1/4"-20 X 1-1/4" SS	2

FOR TRACTION DRIVE MACHINES USE PART # 150-1044  
 FOR PAD ASSIST MACHINES USE PART # 150-1043

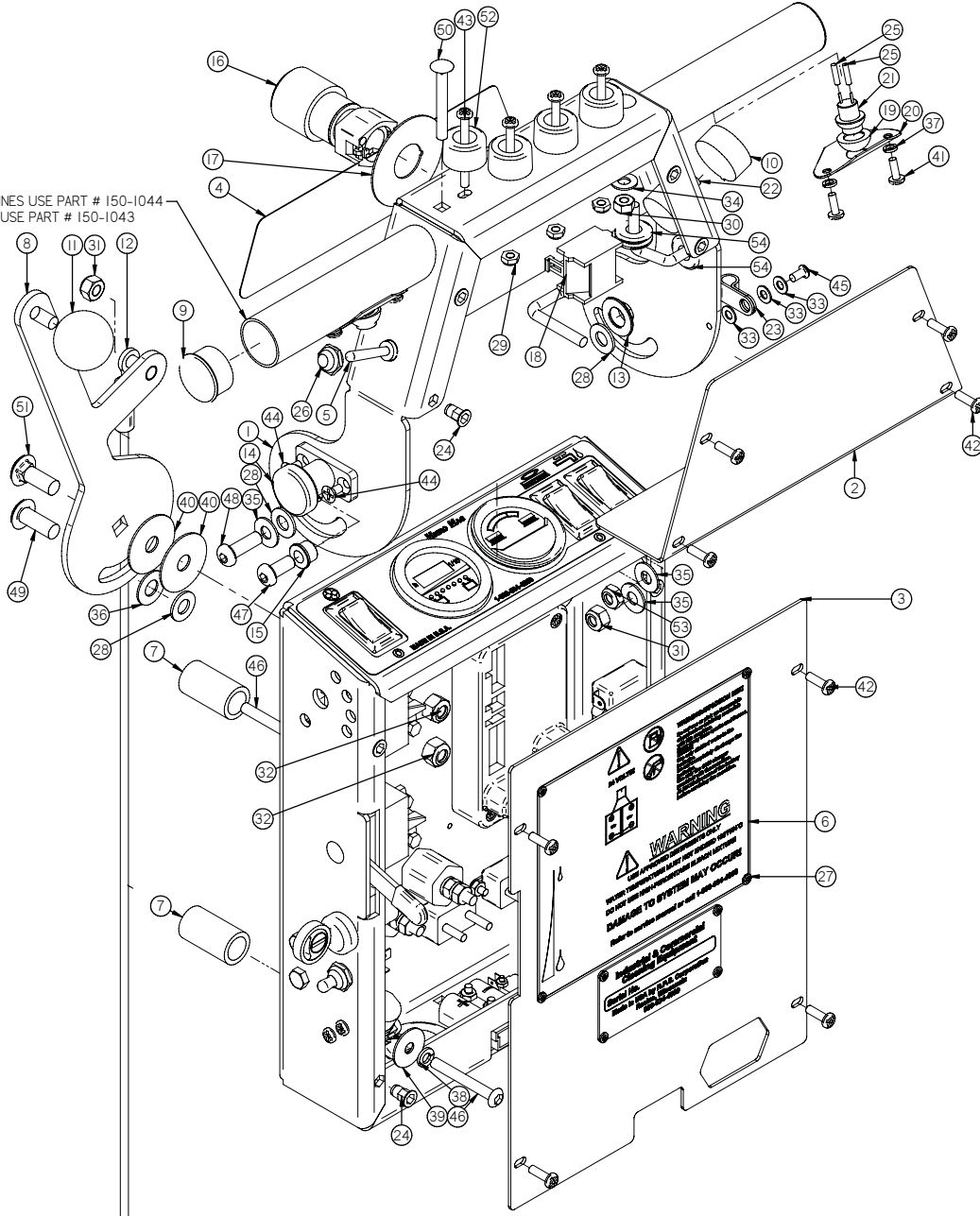

Item	Part No.	Part Description	Qty.	Item	Part No.	Part Description	Qty.
1	150-1040	ADJUSTABLE HANDLE BAR HOLDER	1	28	H-4440024	FW 3/8" X 3/4" NYLON	5
2	150-1042	HANDEL BAR COVER	1	29	H-70858	NYLOK #10-32 SS	4
3	150-2000	TRACTION CONTROL PANEL COVER	1	30	H-70860	NYLOK 1/4"- 20 SS	1
4	150-2016	MICRO MAG STICKER	1	31	H-70861	NYLOK 5/16" - 18 SS	3
5	150-2830	SWITCH, TOGGLE, MOM/OFF/MOM (DPDT)	1	32	H-70862	NYLOK 3/8"-16 SS	2
6	150-7281	EXPLOSION WARNING PLATE	1	33	H-71009	FW #10 SS	3
7	170-2700	SPACER, 1-1/2" LG	4	34	H-71013	FW 1/4 ID X 5/8 OD SS	2
8	170-7100	SQUEEGEE LIFT LEVER	1	35	H-71015	FW 5/16 ID X 3/4 OD SS	6
9	190-1390	END CAP	1	36	H-71017	FW 3/8 ID X 7/8 OD SS	1
10	21-4520	SPEED CONTROL KNOB, RED	1	37	H-71057	LW #8, SS	4
11	21-7101	LIFT KNOB	1	38	H-71063	LW 1/4" SS	1
12	253-7891	SQUEEGEE LIFT CABLE, 30"	1	39	H-71212	FNW 1/4 ID X 1.0 OD SS	1
13	290-1247	BRONZE THRUST BEARING, .50" ID X 1.0" OD X 1/16" TH	2	40	H-71217	FNW 3/8 ID X 1-1/2 OD SS	2
14	290-7050	INDEX PLUNGER	1	41	H-72398	PPH #8-32 X 1/2" S/S	4
15	370-1245	BUSHING	2	42	H-72517	PPH #10-32 X 5/8" SS	5
16	5-300	EMERGENCY SHUT OFF	1	43	H-72556	PPH #10-32 X 2" SS	4
17	5-301	EMERGENCY LEGEND PLATE	1	44	H-72681	FHP #10-32 X 3/8" SS	2
18	5-302	EMERGENCY CONTACT BLACK	1	45	H-73742	BHSCS 10-32 X 3/8" SS	1
19	7-227	BUTTON COVER	2	46	H-73759	BHSCS 1/4 - 20 X 2.0" SS	4
20	7-228	SWITCH MOUNT PLATE	2	47	H-73779	BHSCS 5/16-18 X 3/4"	2
21	7-229D	PUSH BUTTON SWITCH	2	48	H-73780	BHSCS 5/16-18 X 1	2
22	7-292	5K POTENTIOMETER	1	49	H-73815	BHSCS 3/8"- 16 X 1" SS	1
23	H-02239	3/8" VINYL LOOP CLAMP	1	50	H-74423	CB 1/4"- 20 X 2.0" SS	2
24	H-02309	HCN #10-32, LG CRIMP	8	51	H-74436	CB 3/8"- 16 X 1.0" SS	1
25	H-108	HEAT SHRINK	4	52	H-9540	RUBBER BUMPER, 25/32"	4
26	H-11196	PROTECTIVE BOOT, TOGGLE SWITCH, (RED)	1	53	H-NJ05C	JNYL 5/16"- 18 SS	2
27	H-41007	AB4-3A BLIND RIVET	8	54	M-9307K23	GROMMET, 3/8 ID X 7/8 OD X 1/8 TH.	2



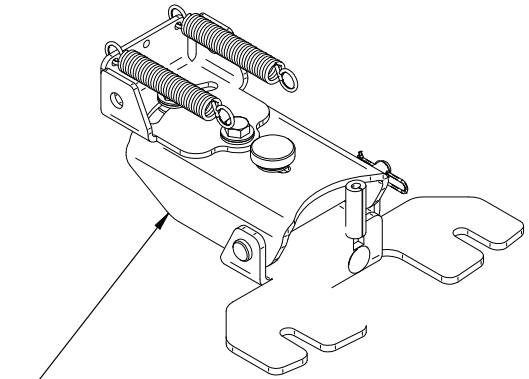
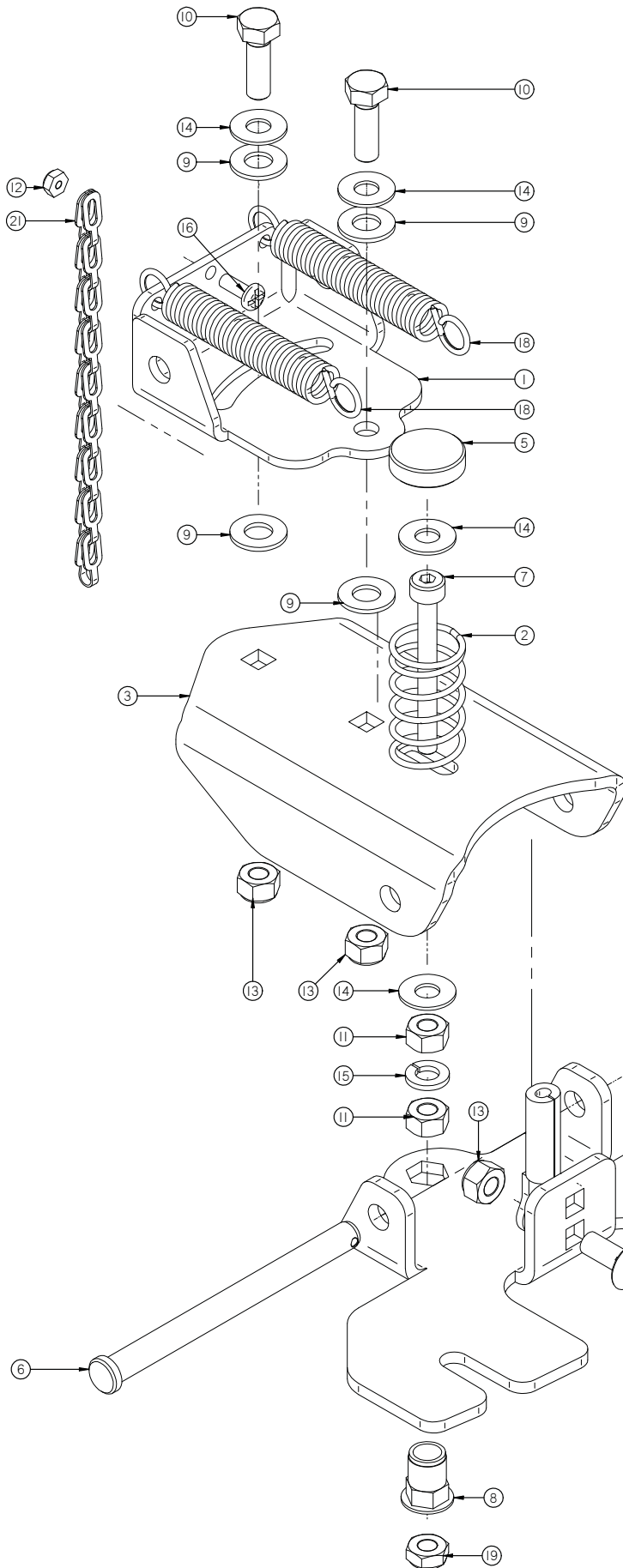

SQUEEGEE TRAIL ARM ASSEMBLY: 150-7155

Item	Part No.	Part Description	Qty.
1	150-7140	SQUEEGEE SWING PLATE	1
2	150-7241	SPRING 5/8" ID X 2.0" LG	1
3	150-7610	UPPER SQUEEGEE TRIANGLE PIVOT	1
4	150-7612	LOWER SQUEEGEE TRIANGLE PIVOT	1
5	4-457	ADJUSTMENT KNOB	1
6	H-00135	3/8" X 4-1/2" CLEVIS PIN	1
7	H-01205	SHCS 5/16-18 X 2-1/2 SS	1
8	H-312HCN	HCN 5/16"-18	1
9	H-4440024	FW 3/8" X 3/4" NYLON	4
10	H-70065	HCS 5/16"- 18 X 1" SS	2
11	H-70711	HN 5/16"- 18 SS	2
12	H-70855	NYLOK #6-32 SS	1
13	H-70861	NYLOK 5/16" - 18 SS	3
14	H-71015	FW 5/16 ID X 3/4 OD SS	4
15	H-71065	LW 5/16" SS	1
16	H-72516	PPH #6-32 X 1/2" SS	1
17	H-74429	CB 5/16"- 18 X 3/4" SS	1
18	H-96544	SPRING 4-1/8" LG X 9/16" OD I42EJ	2
19	H-NJ05C	JNYL 5/16"- 18 SS	1
20	H-RUE14	3/8" RUE RING COTTER	1
21	T-360824S0600	6" GOLD GRADING CHAIN	1



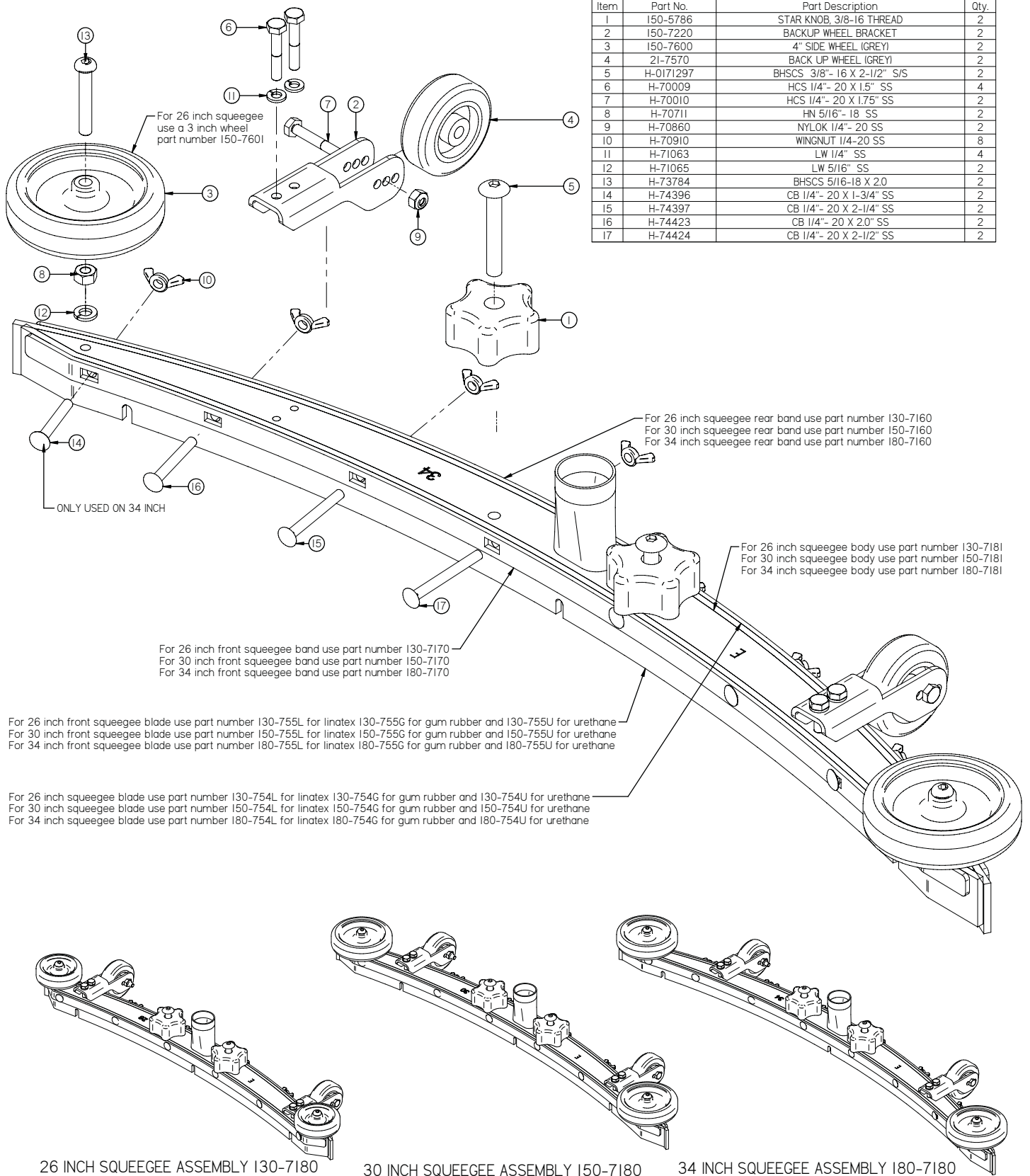

Item	Part No.	Part Description	Qty.
1	150-5786	STAR KNOB, 3/8-16 THREAD	2
2	150-7220	BACKUP WHEEL BRACKET	2
3	150-7600	4" SIDE WHEEL (GREY)	2
4	21-7570	BACK UP WHEEL (GREY)	2
5	H-0171297	BHSCS 3/8"- 16 X 2-1/2" S/S	2
6	H-70009	HCS 1/4"- 20 X 1.5" SS	4
7	H-70010	HCS 1/4"- 20 X 1.75" SS	2
8	H-70711	HN 5/16"- 18 SS	2
9	H-70860	NYLOK 1/4"- 20 SS	2
10	H-70910	WINGNUT 1/4-20 SS	8
11	H-71063	LW 1/4" SS	4
12	H-71065	LW 5/16" SS	2
13	H-73784	BHSCS 5/16-18 X 2.0	2
14	H-74396	CB 1/4"- 20 X 1-3/4" SS	2
15	H-74397	CB 1/4"- 20 X 2-1/4" SS	2
16	H-74423	CB 1/4"- 20 X 2.0" SS	2
17	H-74424	CB 1/4"- 20 X 2-1/2" SS	2

# 24 Clean Caddy

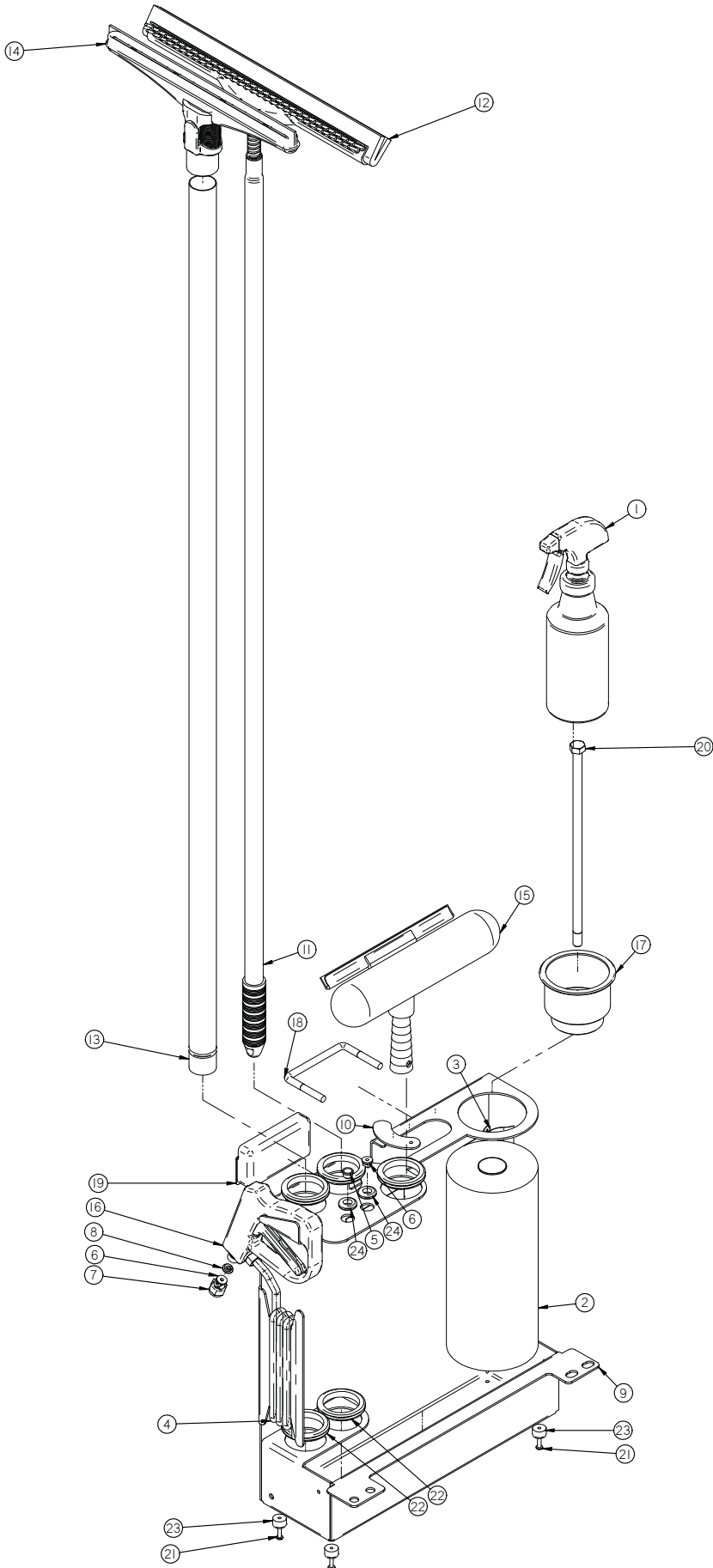

Item	Part No.	Part Description	Qty.
1		ROUND SOAP BOTTLE	1
2		PAPER TOWEL	1
3		BLADE	1
4		SPRAY HOSE	1
5		stream spray tip	1
6		40 deg spray tip	2
7		spray tip nut	1
8		spray tip seal	1
9	150-8810	CLEAN CADDIE	1
10	150-8814	HOSE LATCH	1
11	150-8850	SCRUB BRUSH STICK	1
12	150-8860		1
13	150-8870	TUBE, WAND, STRAIGHT, 59"	1
14	150-8890		1
15	150-8895		1
16	150-8950	SPRAY GUN	1
17	370-0014	CUP HOLDER	1
18	5-834	HOPPER HANDLE	1
19	5-849	RECESSED HANDLE	1
20	H-15237	HCS 1/2"- 13 X 13" GRADE 8	1
21	H-72534	PPH #10-32 X 3/4" S/S	4
22	H-9307K74	GROMMET, 2" ID X 2-5/8" OD	5
23	H-9540	RUBBER BUMPER, 25/32"	4
24	M-9307K22	GROMMET, RUBBER 3/8 ID X 7/8 OD X 5/16 TH.	2

**ROUND DISK BRUSHES:**

BRUSHES	MODEL 17" DISK	MODEL 20" DISK
Super Grit	17-421SS	20-421SS
Tough Grit	17-421S	20-421S
Midi Grit	17-421C	20-421C
Light Grit	17-421PS	20-421PS
Poly (.028)	17-421P	20-421P
Nylon (.016)	17-421N	20-421N
Tampico	17-421T	20-421T
Pad Driver	17-421D	20-421D
Diamond Driver	17-421DD	20-421DD
Pad Retainer #40-434		

**ROUND DISK PADS:**

<b>NOTICE</b>
The ## in Disk Column Denotes Desk Pad Size: 17" or 20"

DISK PADS	DISK	LEVEL	COLOR
Super Black	##-422BB	Very High	Black
Black	##-422B	High	Black
Brown	##-422BR	High	Brown
Green	##-422G	Medium	Green
Blue	##-422BL	Moderate	Blue
Red	##-422R	Moderate	Red
White	##-422W	Light	White

**EDGE PADS AND SCREENS:**

DESCRIPTION	20"×14" SCRUBDECK	13"×19"
White Pad	EDGE-4005	N/A
Red Pad	EDGE-4004	N/A
Blue Pad	EDGE-4003	N/A
Green Pad	EDGE-4002	N/A
Black Pad	EDGE-4001	N/A
White Driver Pad	EDGE-4025	EDGE-4019
60 Grit Sand Screen	EDGE-4026	EDGE-4020
80 Grit Sand Screen	EDGE-4027	EDGE-4021
100 Grit Sand Screen	EDGE-4028	EDGE-4022
120 Grit Sand Screen	EDGE-4029	EDGE-4023
150 Grit Sand Screen	EDGE-4030	EDGE-4024
20 Grit Sand Paper	EDGE-4031	N/A
36 Grit Sand Paper	EDGE-4032	N/A
60 Grit Sand Paper	EDGE-4033	N/A

80 Grit Sand Paper	EDGE-4034	N/A
100 Grit Sand Paper	EDGE-4035	N/A
100 Grit Diamond Polishing Pad	EDGE-4012	N/A
400 Grit Diamond Polishing Pad	EDGE-4013	N/A
800 Grit Diamond Polishing Pad	EDGE-4014	N/A
1500 Grit Diamond Polishing Pad	EDGE-4015	N/A
3000 Grit Diamond Polishing Pad	EDGE-4016	N/A
6000 Grit Diamond Polishing Pad	EDGE-4070	N/A
Tile/Grout Renovator Pad	EDGE-4018	N/A
Microfiber Pad	EDGE-4036	N/A
Abrader Plate	N/A	EDGE-4011
Dominator HD Strip Pad	EDGE-4006	N/A
Maroon ECO Prep Pad	EDGE-4007	N/A
Remover Burnishing Pad	EDGE-4008	N/A
Porko Burnishing Pad	EDGE-4017	N/A
Velcro Pad	300-4023	N/A

**EDGE/ORBITZ GRIP FACE:**

DESCRIPTION	PART#
20" Velcro Grip Face	300-1037
20" Mighty Lok Grip Face	300-01037Z

**SQUEEGEE BLADE KITS & SQUEEGEE ASSEMBLIES:**

SQUEEGEE SIZE	17" DECKS	20" DECKS
26" Squeegee	Optional	Optional
30" Squeegee	Standard	Optional
34" Squeegee	Optional	Standard

SQUEEGEE SIZE	GUM RUBBER BLADE KIT	LINATEX BLADE KIT	URETHANE BLADE KIT	COMPLETE SQUEEGEE ASSEMBLIES
26" Squeegee	130-770G	130-770L	130-770U	130-7180
30" Squeegee	150-770G	150-770L	150-770U	150-7180
34" Squeegee	180-770G	180-770L	180-770U	180-7180

**NOTICE**

Squeegee blade kits include (1) Rear Blade, (1) Front Blade, and (2) Backup Wheels with hardware.

**NOTICE**

Squeegee Assemblies (complete) listed above all come with Linatex blades.

**NOTICE**

Size is stamped into the top of the painted steel squeegee body on all squeegee's.

**NOTICE**

The 26" squeegee is designed for narrow aisles and may not have the same water control around tight turns as the large squeegees.

**BLANK**  
THIS PAGE WAS INTENTIONALLY LEFT BLANK



1711 South Street  
Racine, WI 53404  
[www.rpscorporation.com](http://www.rpscorporation.com)  
Tel. US: 800-634-4060  
Tel. Int: (001) 262-681-3583