



T5

Service Information Manual



NOTE: Refer to page iv for important information for machines with serial number date codes below DC1006 (October, 2006).

FaST
Foam Scrubbing Technology[®]
The Safe Scrubbing Alternative[®]

Hygenic[®] Fully Cleanable Tanks
QA Controls[™]

North America / International

www.tennantco.com

9002333
Rev. 02 (11-2007)



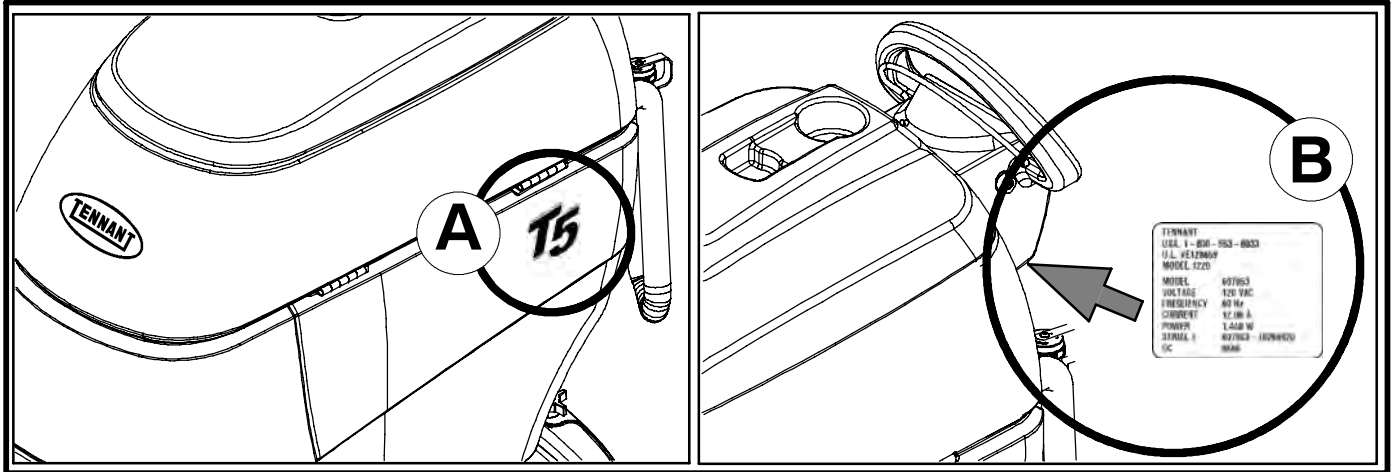

FOR REPLACEMENT PARTS

Identify machine model and serial number.

1. **(A)** Identify the machine model.
2. **(B)** Identify the machine serial number from the data plate.

Refer to the TENNANT Parts Manual.

NOTE: Only use TENNANT Company supplied or equivalent parts. Parts and supplies may be ordered online, by phone, by fax or by mail.

Tennant Company

PO Box 1452

Minneapolis, MN 55440

Phone: (800) 553-8033 or (763) 513-2850

www.tennantco.com

FaST-PAK is a US registered and unregistered trademark of Tennant Company.

Specifications and parts are subject to change without notice.

Copyright © 2006 TENNANT Company, Printed in U.S.A.

T5 Service Information Manual

Table of Contents

	page
MACHINE INFORMATION	
Component Locator.....	1
Machine Specifications.....	5
MAINTENANCE	
CHARGING BATTERIES	7
Battery Charger Specifications.....	7
On-Board Battery Charger Settings.....	7
Using the On-Board Battery Charger.....	7
Using an Off-Board Battery Charger.....	8
On-Board Battery Charger Error Codes.....	9
ADJUSTING SCRUB HEAD BRUSHES	10
Disk Brush Model.....	10
Cylindrical Brush Model.....	10
MACHINE MAINTENANCE	12
Daily Maintenance.....	12
Monthly Maintenance.....	14
Battery Maintenance.....	15
Squeegee Blades.....	15
Motor Maintenance.....	16
FaST System Maintenance.....	16
JACKING UP MACHINE	17
TRANSPORTING MACHINE	17
STORING MACHINE	17
FaST System Freeze Protection.....	17
RECOMMENDED STOCK ITEMS	18
BASIC TROUBLESHOOTING	20
CONTROL PANEL FAULT INDICATOR CODES	21
ELECTRICAL	
Electrical Schematic.....	22
Wiring Harness Detail.....	24
35 Pin Connector Detail.....	30
Control Panel LED Details.....	31
Electrical Symbols & Terms.....	32
Key OFF Power Distribution (Off-Board Charger Disconnected).....	33
Key OFF Power Distribution (Off-Board Charger Connected).....	34
Key OFF Power Distribution (On-Board Charger Disconnected).....	35
Key OFF Power Distribution (On-Board Charger Connected).....	36
Key OFF Propel System.....	37
Key ON Power Distribution.....	38
Propel Forward System.....	39
Propel Reverse System.....	40
Propel System Neutral.....	41
Scrub Brushes.....	42
Vacuum Fan System.....	43
Conventional Solution Solenoid Valve.....	44
FaST Water Pump.....	45
Hour Meter & Off-Aisle Wand Water Pump.....	46
Scrub Head Actuator LOWER (Extend).....	47
Scrub Head Actuator RAISE (Retract).....	48
Operational Modes & Interlocks.....	49
Diagnostic LED Codes.....	50
High Current Faults.....	50
Diagnostic & Configuration Modes.....	51
Display Software Revision Mode.....	52
Self Test Mode.....	54
Input Display Mode.....	55
Manual Mode.....	57
Propel Diagnostics Mode.....	59
Battery Select Mode.....	60
Supervisor Mode.....	61
Scrub Propel Speed Selection Mode.....	62
Scrub Head Selection Mode.....	63
Inputs & Outputs Table.....	64

T5 Service Information Manual



BEFORE CONDUCTING TESTS:



- Read and Follow ALL Safety Warnings and Precautions in Operator's Manual
- Always use an ESD (Electrostatic Discharge) strap when working near the Control Board
- Be cautious when working near Control Board – *Battery voltage is always present, even with Key OFF*
- Always Disconnect Batteries when removing or replacing components

DURING TESTS:

- Call Technical Services if Diagnostic Time Exceeds One Hour with Unknown Cause or Course of Action

IMPORTANT INFORMATION FOR MACHINES WITH SERIAL NUMBER DATE CODES PRIOR TO DC1006 (October, 2006)

Potential rolling hazard may exist when transporting the machine on a ramp or incline with key turned to the “off” position. The machine could roll at an undesirable speed creating the risk for potential injury or property damage.

To ensure operator safety and to prevent potential property damage, Tennant Company mandates that the existing control box assembly be replaced with the Control Box Kit (p/n 9003250). For more information, refer to Technical Service Bulletin # 130. To determine if the machine in question has been updated with the new Control Box Kit, refer to the picture below.

If the Brake Relay (CR2) is present in the Control Box, the machine has already been updated and no further action is required. If the Brake Relay (CR2) is NOT present in the Control Box, follow the instructions in Technical Service Bulletin # 130.

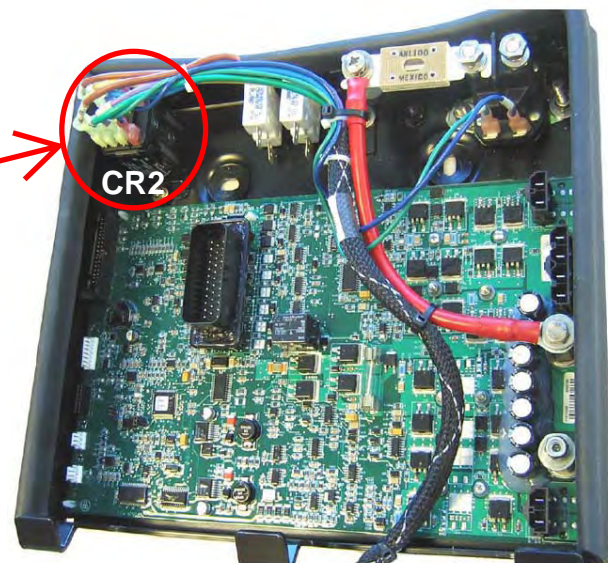

CONTROL BOX ASSEMBLY

T5 Component Locator

(Page 1 of 4)



TOUCH PANEL

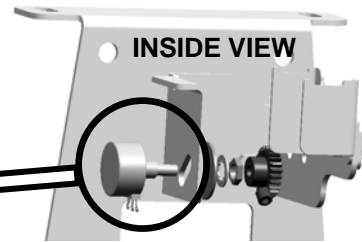
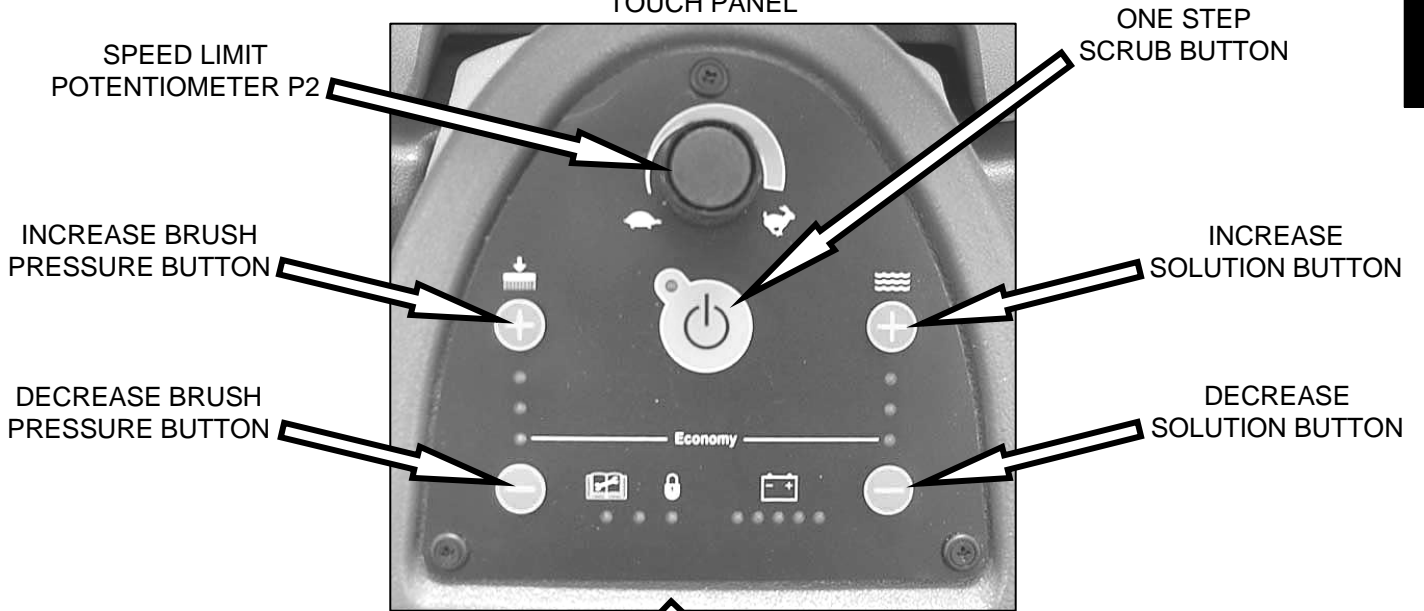

THROTTLE POSITION SENSOR P2 (POTENTIOMETER)

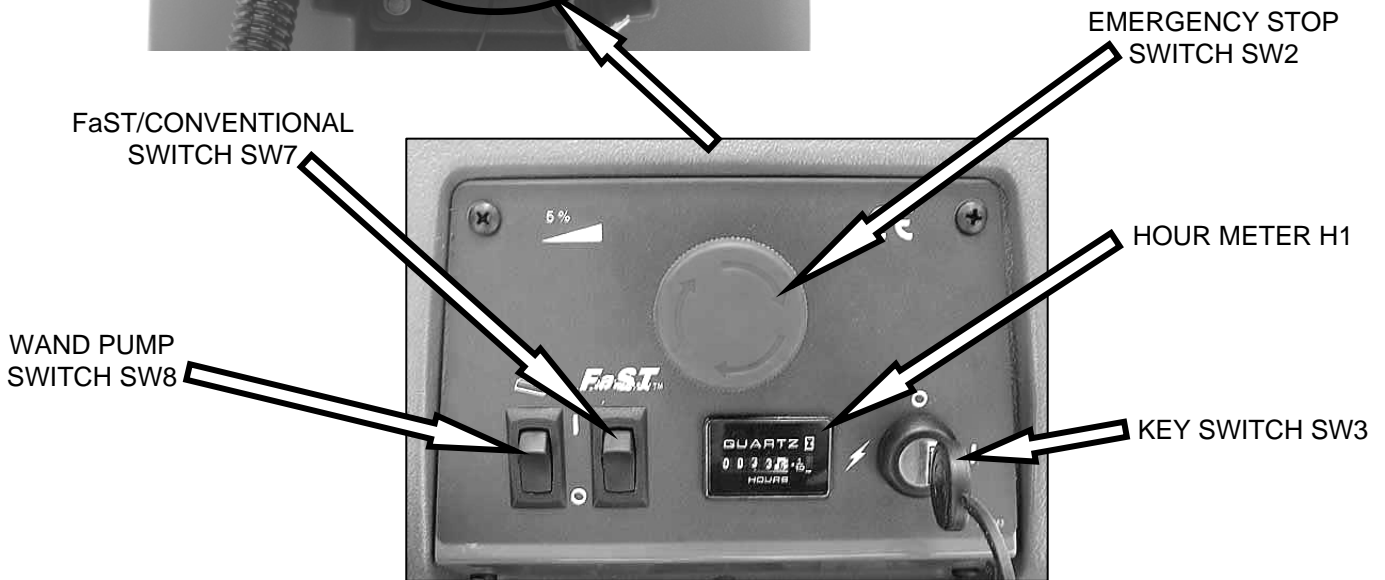

SWITCH PANEL

T5 Component Locator

(Page 2 of 4)

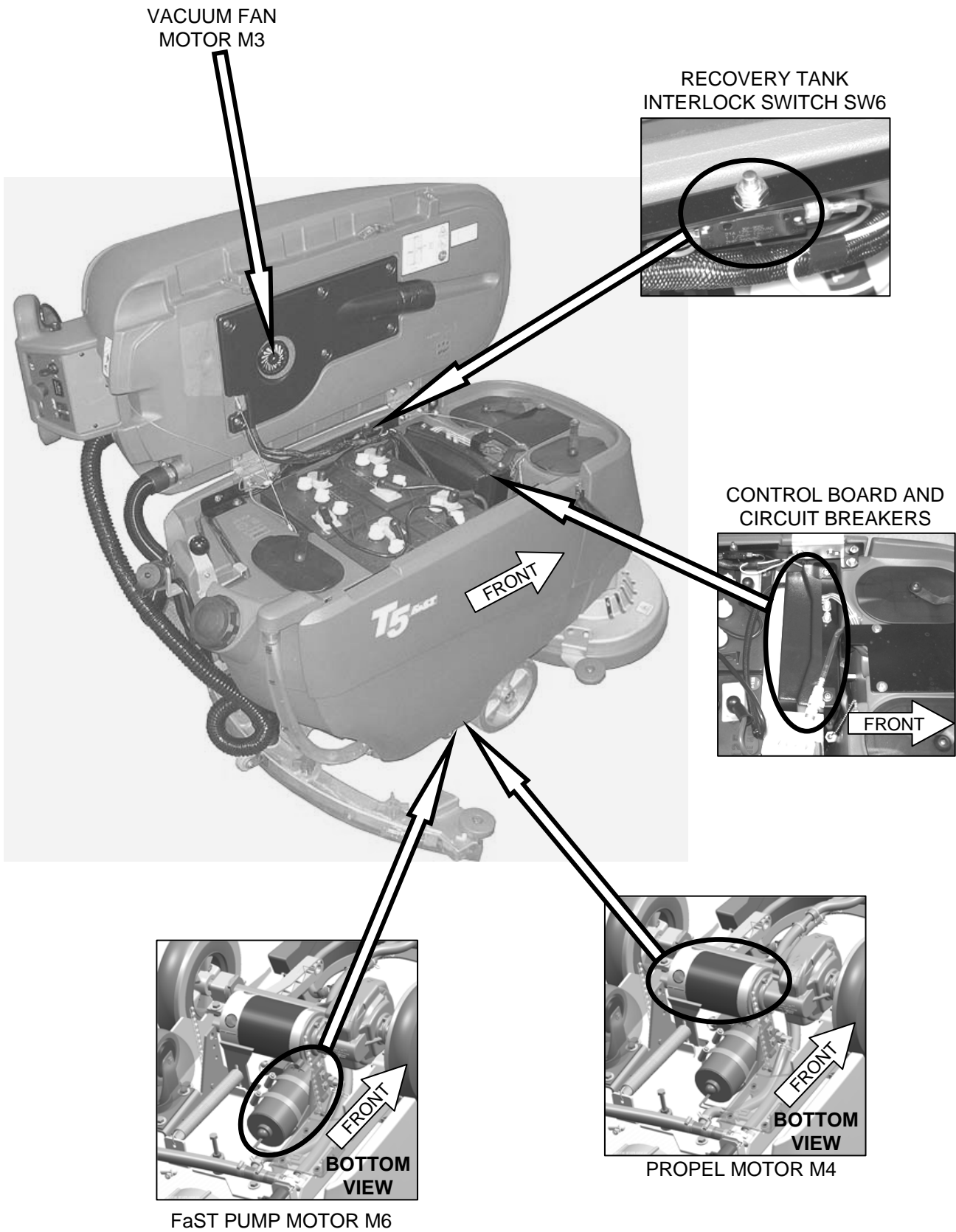

T5 Component Locator

(Page 3 of 4)

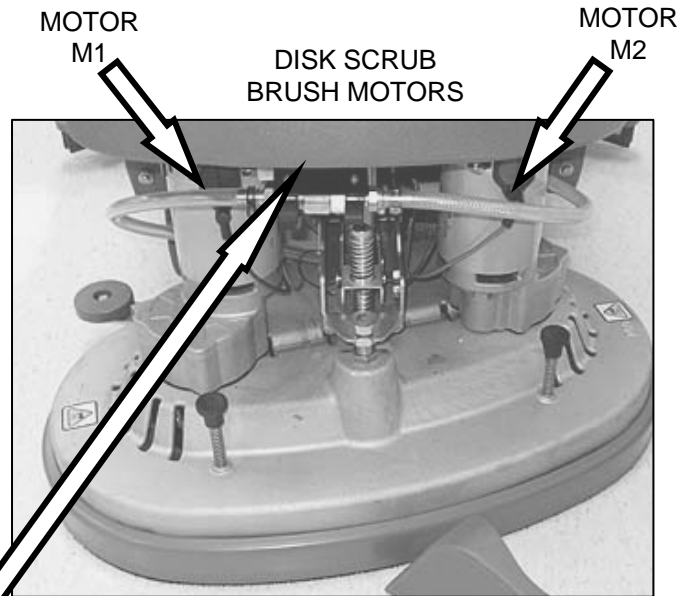
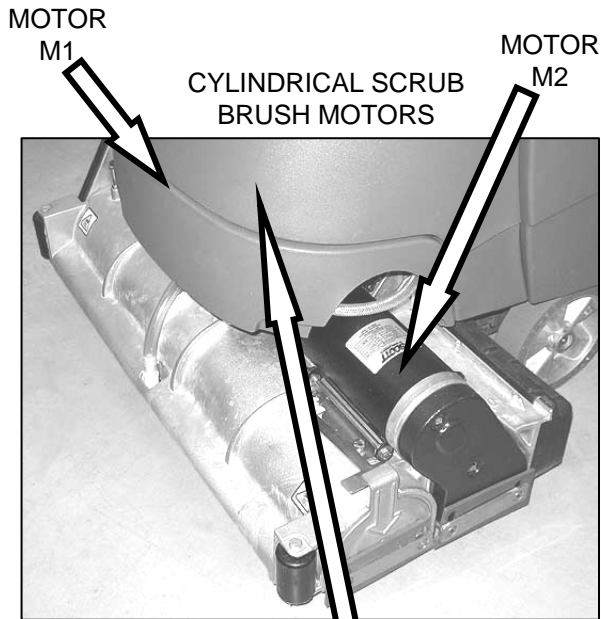

ACTUATOR MID-STROKE SWITCH SW5
ACTUATOR RETRACT SWITCH SW9
ACTUATOR EXTEND LIMIT SWITCH SW10

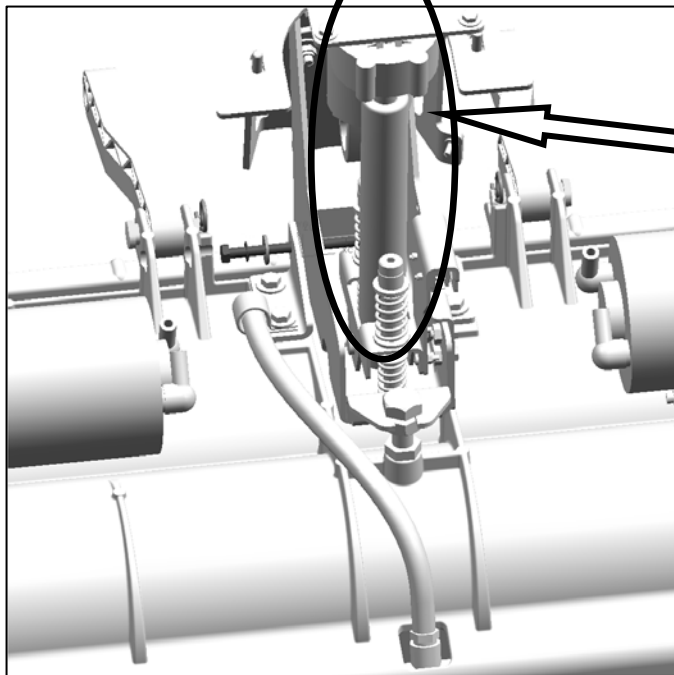

SCRUB HEAD ACTUATOR M5

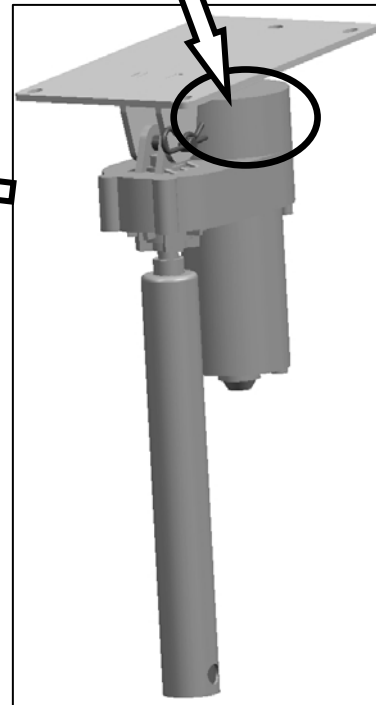

SCRUB HEAD ACTUATOR M5

T5 Component Locator

(Page 4 of 4)

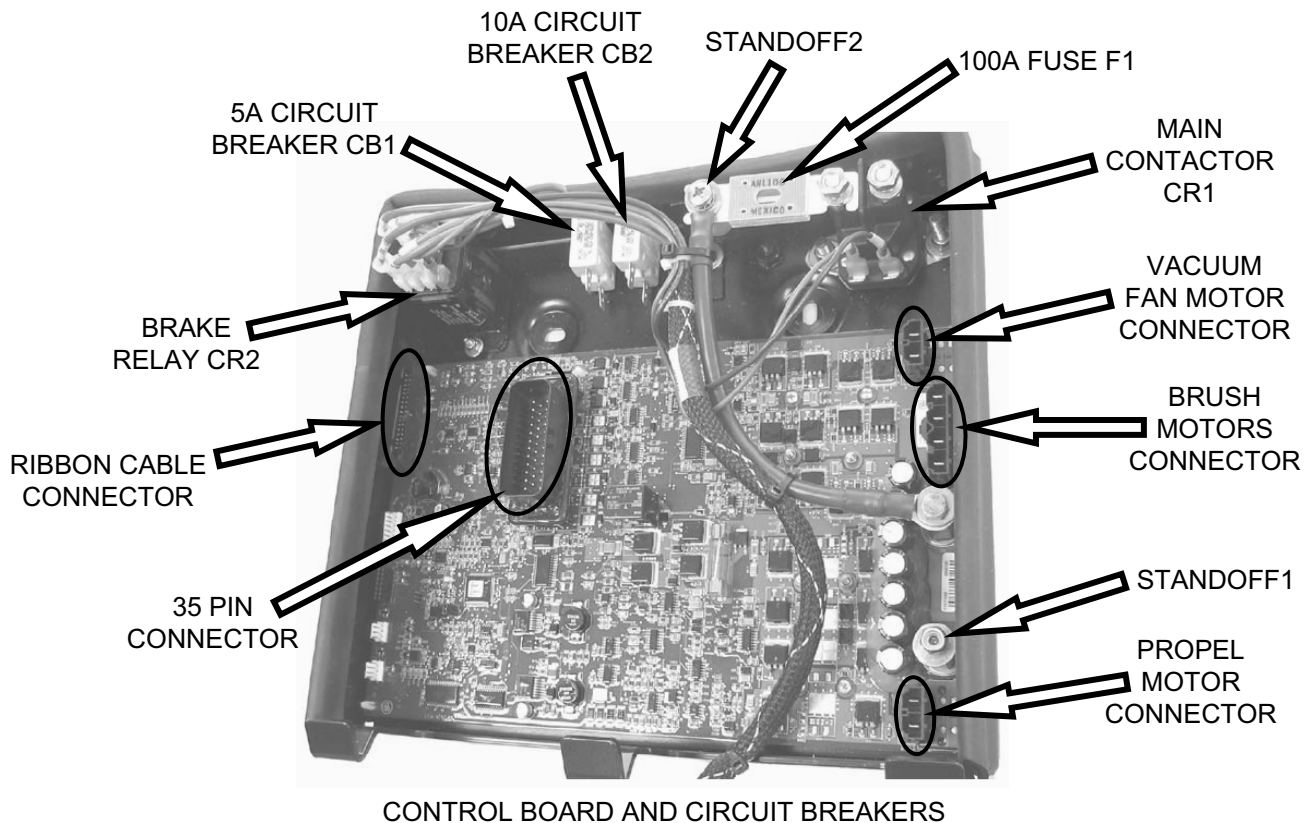
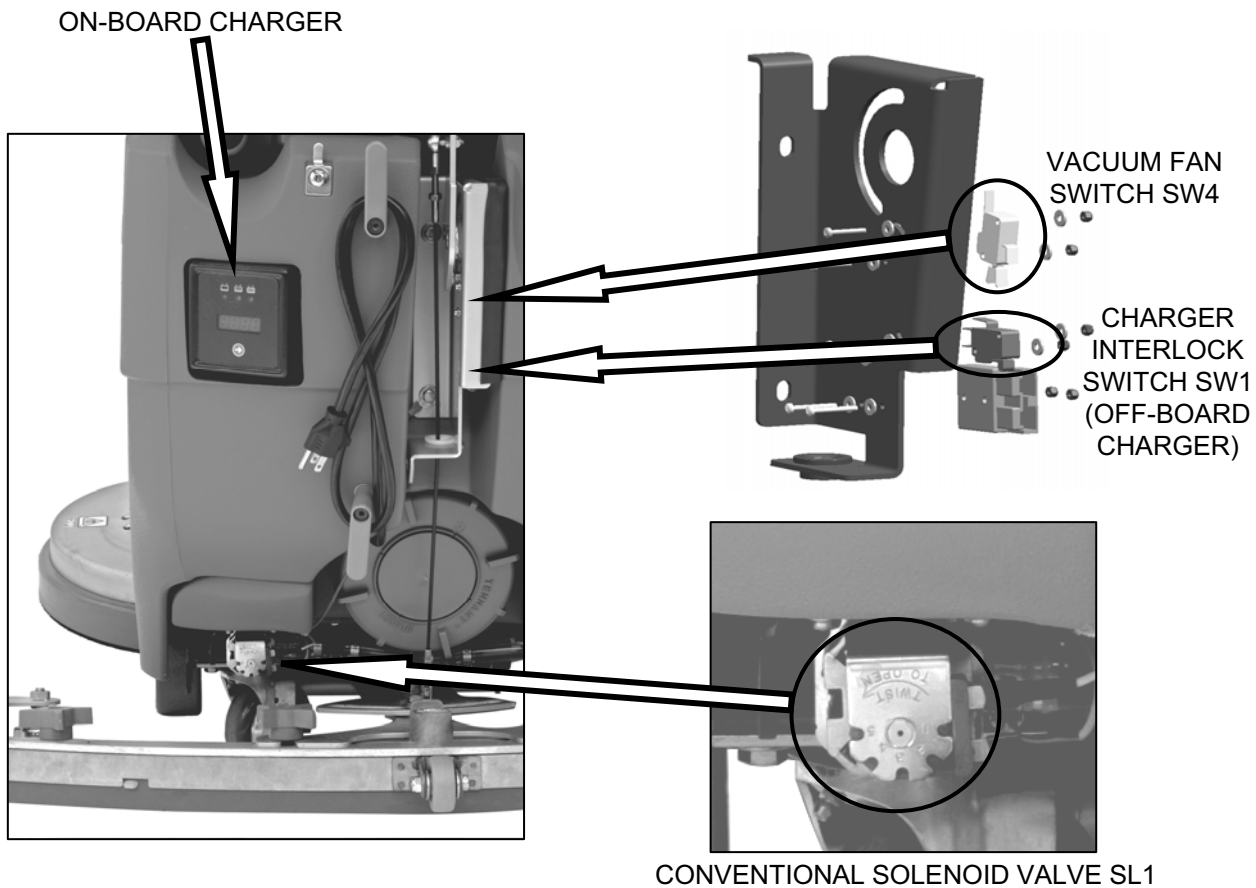



MACHINE SPECIFICATIONS

MODEL	Disk, 600mm	Disk, 700mm	Disk, 800mm	Cylindrical, 650mm	Cylindrical, 800mm
LENGTH	1350mm (53 in)				
WIDTH	580mm (23 in)				
HEIGHT	1120mm (44 in)				
MINIMUM AISLE TURN	1346mm (53 in)	1499mm (59 in)	1626mm (64 in)	1575mm (62 in)	1638mm (64.5 in)
WEIGHT	143 Kg (316 lbs)	165 Kg (365 lbs)	171 Kg (377 lbs)	162 Kg (357 lbs)	166 Kg (365 lbs)
WEIGHT WITH BATTERIES	263 Kg (580 lbs)	276 Kg (609 lbs)	282 Kg (621 lbs)	281 Kg (621 lbs)	285 Kg (629 lbs)
RECOVERY TANK CAPACITY	102 L (27 Gal)				
SOLUTION TANK CAPACITY	85 L (22.5 Gal)				
DRIVE SYSTEM	Transaxle, 24 V, .19 Kw (.25 hp)				
TRAVEL SPEED, MAXIMUM	Cleaning: 67 m/min (220 ft/min) Transporting: 72 m/min (235 ft/min)				
PRODUCTIVITY RATE Theoretical	2450m ² (26,400ft ²)/hr	2860m ² (30,800ft ²)/hr	3270m ² (35,200ft ²)/hr	2660m ² (28,600ft ²)/hr	3270m ² (35,200ft ²)/hr
PRODUCTIVITY RATE Estimated Actual	1660m ² (17,875ft ²)/hr	1930m ² (20,800ft ²)/hr	2230m ² (24,000ft ²)/hr	1785m ² (19,200ft ²)/hr	2230m ² (24,000ft ²)/hr
CLEANING PATH WIDTH	600mm (24 in)	700mm (28 in)	800mm (32 in)	650mm (26 in)	800mm (32 in)
BRUSH DIAMETER	302mm (11.9 in)	353mm (13.9 in)	404mm (15.9 in)	151mm (5.9 in)	151mm (5.9 in)
BRUSH PRESSURE	18/36/54 Kg (40/80/120 lbs)				
SOLUTION FLOW RATE - Low:	1.70 L (.45Gal)/min	1.90 L (.50Gal)/min		1.70 L (.45Gal)/min	1.90 L (.50Gal)/min
SOLUTION FLOW RATE - Med:	1.30 L (.35Gal)/min	1.51 L (.40Gal)/min		1.30 L (.35Gal)/min	1.51 L (.40Gal)/min
SOLUTION FLOW RATE - Max:	.95 L (.25Gal)/min	1.14 L (.30Gal)/min		.95 L (.25Gal)/min	1.14 L (.30Gal)/min
SQUEEGEE WIDTH	908mm (35.7 in) standard	1051mm (41.3 in) standard	1185mm (46.6 in) standard	1051mm (41.3 in)	1185mm (46.6 in)
	800mm (31.5 in)	908mm (35.7 in)	1051mm (41.3 in)		
BRUSH MOTOR	Qty 2, .55Kw (.75hp), 220rpm, 24V, 29A			Qty 2, .47Kw (.63hp), 1500rpm, 24V, 23A	
VACUUM MOTOR	640W (.85 hp), 3-stage 5.7, 24V, 26A				
WATER LIFT/AIR FLOW	55mm (62 in) H ² O/ 32.4 L ³ (69ft ³)/m				
BATTERIES	Qty 4, 6V				
RUN TIME PER CHARGE	Minimum 3.5 hrs / Maximum 4.75 hrs				
BATTERY CAPACITY	WET (lead Acid) = 235Ah/20hr rate Sealed (Gel)= 200Ah/20 hr rate				
ONBOARD CHARGER	120VAC, 10A, 50/60Hz, 24VDC, 20A output / 230VAC, 5A, 50/60Hz, 24VDC, 20A output				
TOTAL POWER CONSUMPTION	50 Amp nominal				
VOLTAGE DC	24 VDC				
PROTECTION GRADE	IPX3				
SOUND POWER LEVEL	79.5dB			81dB	
DECIBEL RATING AT OPERATOR'S EAR, INDOORS.*	67dB(A)			68dB(A)	
VIBRATION AT CONTROLS	<.1188m/s ² (<.39ft/s ²)			<.103m/s ² (<.34ft/s ²)	
ACCELERATION RATE ON OPERATOR - MAX.	.179m (.56ft) /s ²				
GRADE LEVEL, MAX.	Scrubbing 5% (3°), Transporting 8% (5°)				

* Sound pressure (ISO 11201) as recommended by the American Association of Cleaning Equipment Manufacturers (AACEM) and OSHA.

FaST SYSTEM	Disk, 600mm	Disk, 700mm	Disk, 800mm	Cylindrical, 650mm	Cylindrical, 800mm
PRODUCTIVITY RATE Estimated Actual	1865m ² (20,075ft ²)/hr	2115m ² (22,750ft ²)/hr	2440m ² (26,250ft ²)/hr	1950m ² (21,000ft ²)/hr	2440m ² (26,250ft ²)/hr
SOLUTION PUMP	24 Volt DC, 3.5 A, 5.6L (1.5 Gal)/min open flow, 4.13 Bar (60psi) bypass setting				
SOLUTION FLOW RATE	0.57 L (0.15 Gal) /min.	0.83 L (0.22 Gal) /min.		0.57 L (0.15 Gal) /min.	0.83 L (0.22 Gal) /min.
CONCENTRATE FLOW RATE	0.57CC (0.0193oz)/min.	0.83CC (0.028oz)/min.		0.57CC (0.0193oz)/min.	0.83CC (0.028oz)/min.
CONCENTRATE TO WATER DILUTION RATIO	1:1000				

MACHINE DIMENSIONS

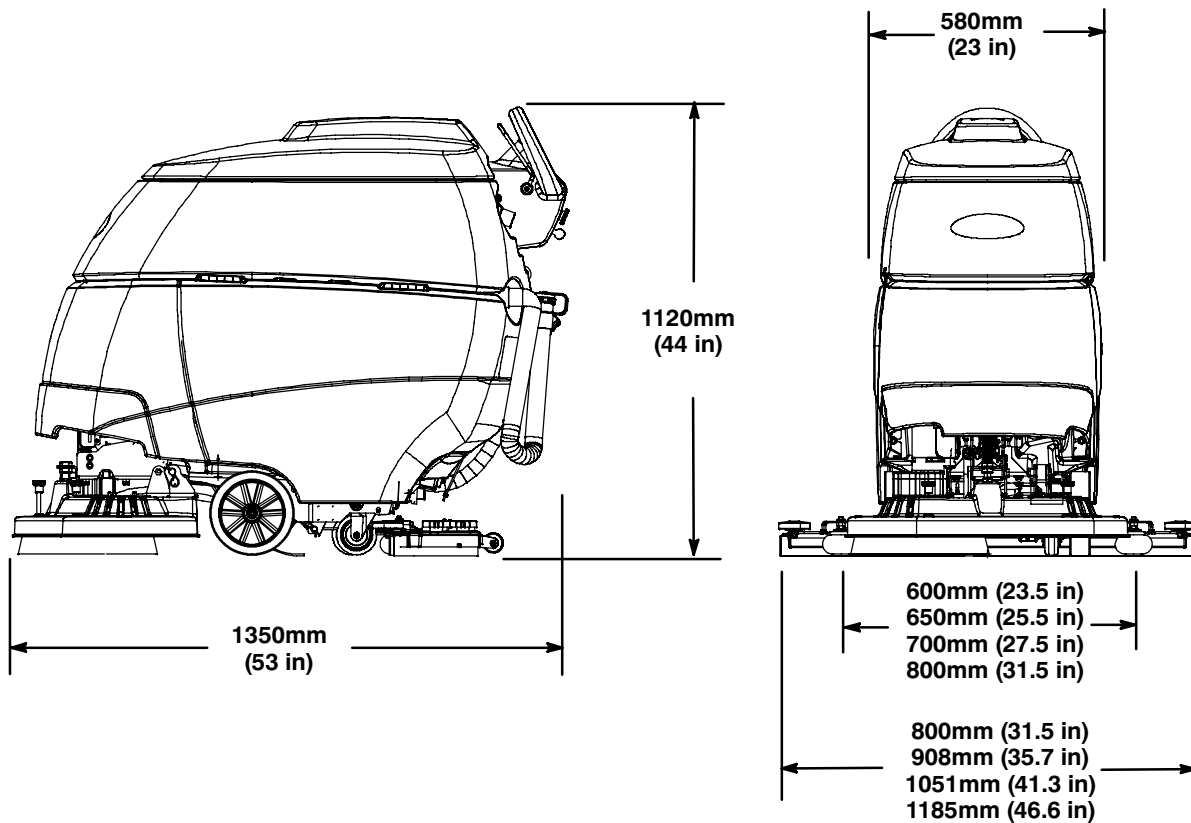

T5 –Maintenance

(Page 1 of 15)

CHARGING BATTERIES

ATTENTION: To prolong the life of the batteries only recharge the batteries if the machine was used for a total of 30 minutes or more. Do not leave batteries discharged for lengthy periods.

⚠ WARNING: Fire Or Explosion Hazard. Batteries Emit Hydrogen Gas. Keep Sparks And Open Flame Away. Keep Battery Compartment Open When Charging.

FOR SAFETY: When servicing batteries, wear protective gloves and eye protection when handling batteries and battery cables. Avoid contact with battery acid.

BATTERY CHARGER SPECIFICATIONS:

- CHARGER TYPE:
 - FOR SEALED (Gel) BATTERIES
 - FOR WET (Lead acid) BATTERIES
- OUTPUT VOLTAGE - 24 VOLTS
- OUTPUT CURRENT - 20 AMPS
- AUTOMATIC SHUTOFF CIRCUIT
- FOR DEEP CYCLE BATTERY CHARGING

ON-BOARD BATTERY CHARGER SETTINGS:

If your machine is equipped with the on-board charger, the charger settings must be set for your battery type before charging. Failure to properly set will result in battery damage.

To determine your battery type, see battery label. Contact your battery supplier if not specified.

To verify what the charger is currently for, connect the charger cord into an electrical receptacle. The charger will display a sequence of codes. One of the codes will either read "GEL" or "Acid" (Figure 40).

GEL = Set for sealed/maintenance free batteries
Acid = Set for wet/lead acid batteries



FIG. 40

To change the setting, unplug the charger, peel up the corner of the display label and set the switches accordingly (Fig. 41). The charger cord must be unplugged when resetting.



FIG. 41

USING THE ON-BOARD BATTERY CHARGER

IMPORTANT: Before charging, make sure that the charger setting is properly set for your battery type (See ON-BOARD CHARGER SETTINGS).

1. Transport the machine to a well-ventilated area.
2. Park the machine on a flat, dry surface. Turn the key off and set the parking brake, if equipped.
3. If charging wet (lead acid) batteries check the fluid level before charging (See BATTERY MAINTENANCE).
4. Prop up the recovery tank for ventilation (Figure 42).



FIG. 42

5. Connect the charger's AC power supply cord into a properly grounded receptacle (Figure 43).

NOTE: The machine will not operate when charging.

T5 –Maintenance

(Page 2 of 15)



FIG. 43

6. The charger will display a sequence of codes once the cord is connected (Figure 44).

Three-digits + the following code:

A = Charging current

U = Battery Voltage

h = Charging time

C = Charging ampere-hours [Ah]

E = Energy used [Kwh]

“GEL” or “Acid” = Battery type the charger is currently set for. Before charging make sure your battery type matches the display:

GEL=Sealed, Acid=WET (lead acid). To change setting, see ON-BOARD CHARGER SETTINGS.

Press the arrow button to review the codes.



FIG. 44

7. Once the charging cycle begins, the indicator lights will progress from red, yellow to green. When the green indicator light comes on, the charging cycle is done. Unplug the charger cord.

If the charger detects a problem, the charger will display an error code (See ON-BOARD BATTERY CHARGER ERROR CODES).

USING AN OFF-BOARD BATTERY CHARGER (OPTION)

1. Transport the machine to a well-ventilated area.
2. Park the machine on a flat, dry surface. Turn the key off and set the parking brake, if equipped.
3. If charging wet (lead acid) batteries, check the fluid level before charging (See BATTERY MAINTENANCE).
4. Prop up the recovery tank for ventilation (Figure 45).



FIG. 45

5. Connect the charger's DC cord into the machine's battery receptacle (Figure 46).
6. Connect the charger's AC power supply cord into a properly grounded receptacle (Figure 46).



FIG. 46

7. The supplied charger will automatically begin charging and shut off when fully charged.

NOTE: The machine will not operate when charging.

ATTENTION: Do not disconnect the charger's DC cord from the machine's receptacle when the charger is operating. Arcing may result. If the charger must be interrupted during charging, disconnect the AC power supply cord first.

T5 –Maintenance

(Page 3 of 15)

ON-BOARD BATTERY CHARGER ERROR CODES

DISPLAY CODE	FAULT	SOLUTION
bat	Loose or damaged battery cable	Check battery cable connections.
	Battery exceeded maximum voltage level.	No action necessary.
E01	Exceeded maximum battery voltage allowed.	No action necessary.
E02	Safety thermostat exceeded maximum internal temperature.	Check if the charger vents are obstructed.
E03	Exceeded maximum time for charging phase leaving the batteries undercharged due to a sulfated or faulty battery.	Repeat the charging cycle and if the error code E03 reappears check battery or replace it.
SCt	Safety timer exceeded maximum charging time. Interrupts charging cycle.	Replace battery.
Srt	Possible internal short circuit.	Contact Service Center.



T5 –Maintenance

(Page 4 of 15)

ADJUSTING SCRUB HEAD BRUSHES

To ensure optimum scrubbing performance periodically check the scrub head for proper adjustment.

FOR SAFETY: Before adjusting scrub head, stop machine on level surface, remove key and set parking brake if equipped.

DISK MODEL

Tools required: Measuring device, 27mm (1-1/16 in) wrench and 24mm (15/16 in) wrench

1. With brushes installed, lower the scrub head and apply medium brush pressure.
2. Turn machine off and remove key.
3. From the center front and back of scrub head, measure the distance from the top edge of scrub head to the floor (Figure 47).



FIG. 47

4. If scrub head is not level, loosen the lock nut and turn the scrub head leveling screw to level. Tighten down the lock nut once head is level (Figure 48).



FIG. 48

CYLINDRICAL BRUSH MODEL

After installing a new set of cylindrical brushes check the brush pattern to ensure proper brush adjustment. Brushes that are not properly adjusted will result in premature wear and poor scrubbing performance (Figure 49).

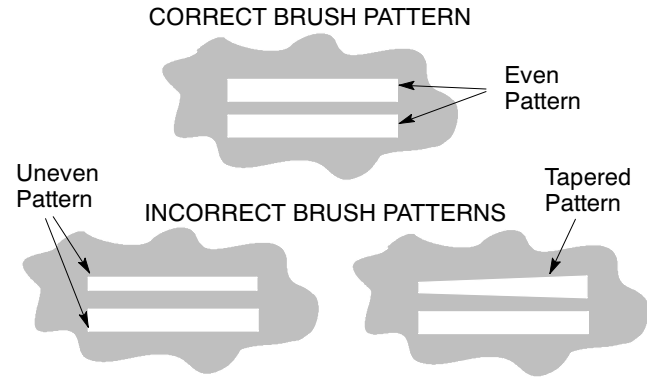

FIG. 49

To Inspect the Brush Pattern:

1. Position the machine on a dry dusty floor or apply a powdered substance, such as chalk.
2. Disconnect the drive motor wire connector to keep machine from moving forward (Figure 50).



FIG. 50

3. Lower the scrub head to the floor and apply maximum brush pressure.
4. Shut off the solution flow.
5. Pull the control handle bail to create a brush pattern on the floor.
6. Raise the scrub head and pull the machine away.
7. Observe the brush pattern on floor. If the brush pattern is uneven or tapered, adjustment is required.
8. Reconnect drive motor wire.

T5 –Maintenance

(Page 5 of 15)

To Adjust an Uneven Brush Pattern:

Tools required: Measuring device, 27mm (1-1/16 in) wrench and 24mm (15/16 in) wrench

1. Measure the distance from the front edge of the scrub head to the floor and from the back edge of the scrub head to the floor (Figure 51). The measurements should be the same.



FIG. 51

2. To level the scrub head, loosen the lock nut and turn the leveling screw clockwise to lower the rear of the scrub head or counter-clockwise to lower the front (Figure 52).



FIG. 52

3. Recheck brush pattern.

NOTE: Replace brushes when worn to 15mm (5/8”).

To Adjust a Tapered Brush Pattern:

Tools required: 10mm (3/8 in) wrench and 6mm hex wrench

1. Raise the scrub head off floor and remove key.
2. Remove the idler plate from the brush (Figure 53).



FIG. 53

3. Hold the brush plug shaft with a wrench and loosen the 6mm hex screw (Figure 54).

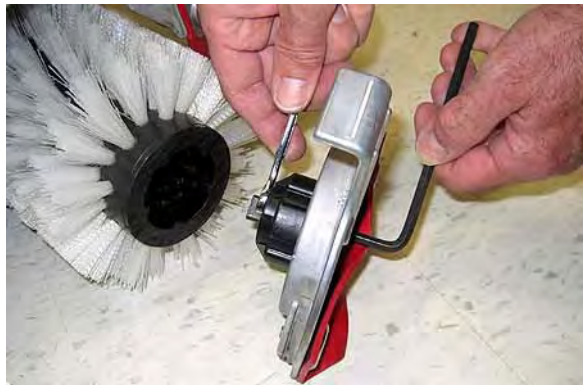

FIG. 54

4. To lower the brush end, turn the shaft clockwise for the front brush and counter-clockwise for the rear brush. Retighten hex screw (Figure 55).



FIG. 55

5. Recheck brush pattern.

NOTE: Replace brushes when worn to 15mm (5/8”).



T5 –Maintenance

(Page 6 of 15)

MACHINE MAINTENANCE

To keep the machine in good working condition, it's important that the following maintenance procedures are performed on a routine basis.

⚠ WARNING: Electrical Hazard. Disconnect Battery Cables Before Servicing Machine.

DAILY MAINTENANCE (After Every Use)

1. Drain the recovery tank (Figure 56).



FIG. 56

2. Rinse and clean out the recovery tank (Figure 57).



FIG. 57

3. Remove the recovery tank float shut-off screen and clean (Figure 58).



FIG. 58

4. Remove the debris tray and empty (Figure 59)



FIG. 59

5. Drain the solution tank (Figure 60).

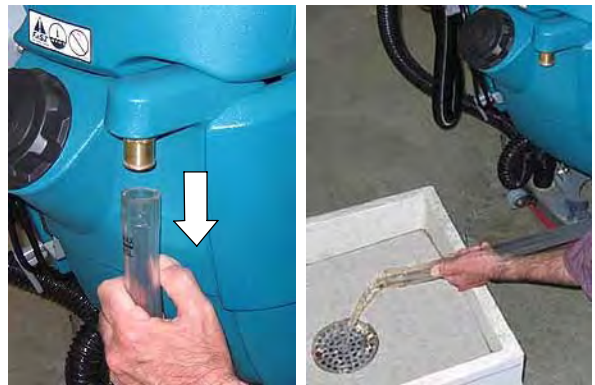

FIG. 60

6. Clean the solution tank filter (Figure 61).



FIG. 61

7. Rotate pad or replace when worn (Figure 62).

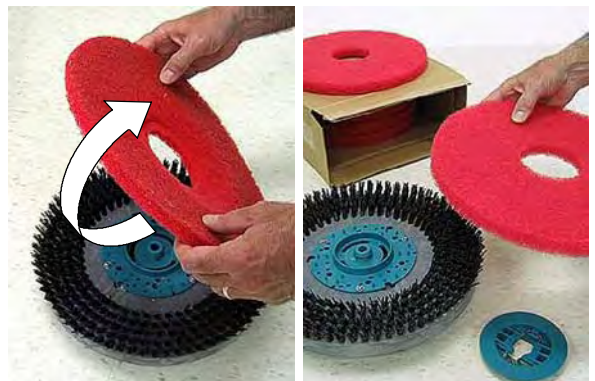

FIG. 62

T5 –Maintenance

(Page 7 of 15)

8. Empty and rinse out the debris trough (Figure 63).

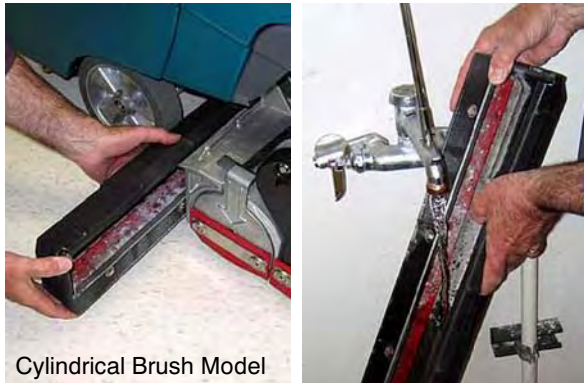

FIG. 63

9. Inspect the cylindrical brushes for wear. Rotate brushes from front-to-rear every 50 hours (Figure 64). Replace when worn to a length of 15mm (5/8").

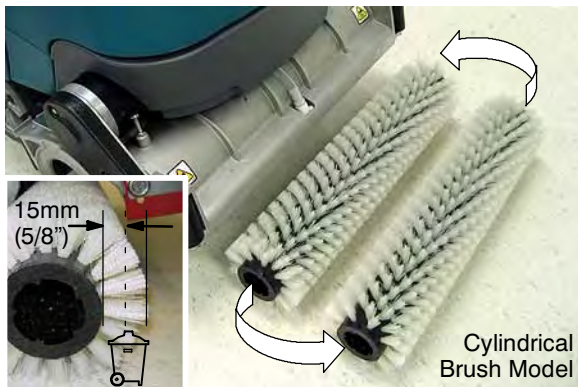

FIG. 64

10. Remove debris buildup from the underside of the cylindrical brush scrub head, including the idler plates and drive hubs (Figure 65).

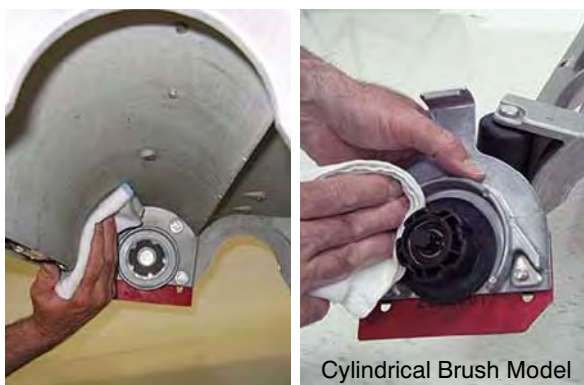

FIG. 65

11. Wipe the squeegee blades clean (Figure 66). Store the squeegee assembly in the raised position to prevent blade damage.



FIG. 66

12. Check the condition of the squeegee blade wiping edge (Figure 67). Rotate blade if worn (See SQUEEGEE BLADES).



FIG. 67

13. Clean the machine with an all purpose cleaner and damp cloth (Figure 68).

FOR SAFETY: When cleaning machine, do not power spray or hose off machine. Electrical malfunction may occur.



FIG. 68



T5 –Maintenance

(Page 8 of 15)

14. Inspect the condition of the scrub head skirt, replace if worn or damaged (Figure 69).

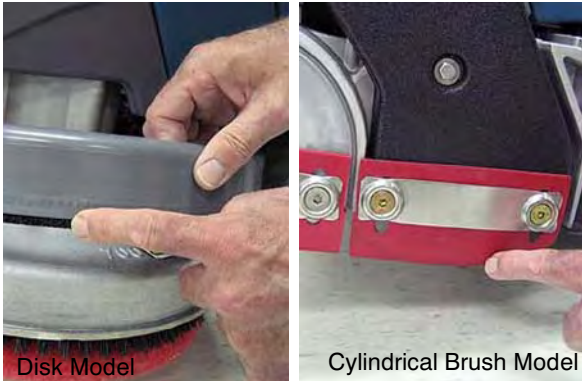

FIG. 69

- M 15. FaST Model: Connect the FaST-PAK supply hose to the storage plug when not in use (Figure 70). Remove any dried concentrate from the hose connector by soaking it in warm water.



FIG. 70

16. Clean wet/lead acid batteries to prevent corrosion and check for loose battery cable connections (See BATTERY MAINTENANCE).
17. Recharge the batteries (Figure 71). To prolong the life of the batteries, only recharge the batteries if the machine was used for a total of 30 minutes or more.



FIG. 71

MONTHLY MAINTENANCE

1. Check the cylindrical brush belt tension every 100 hours (Figure 72). Belt tension should flex 3mm (0.1 in) at midpoint, with 1.13–1.22 Kg (2.5–2.7 lbs) force.

⚠ WARNING: Electrical Hazard. Disconnect Battery Cables Before Servicing Machine.



FIG. 72

2. Inspect and clean the recovery tank cover seal (Figure 73). Replace if damaged.



FIG. 73

3. Lubricate all pivot points and rollers with a water resistant grease.
4. Lubricate the casters with a water resistant grease (Figure 74).



FIG. 74

T5 –Maintenance

(Page 9 of 15)

5. Clean the parking brake clamp with a cleaning solvent.
6. Check the machine for loose nuts and bolts.
7. Check the machine for leaks.

BATTERY MAINTENANCE (Wet/lead acid batteries)

1. Check battery fluid level frequently to prevent battery damage. The fluid should be at the level shown (Figure 75). Add distilled water if low. DO NOT OVERFILL, the fluid may expand and overflow when charging.



CORRECT BATTERY FLUID LEVEL:

Before Charging

After Charging

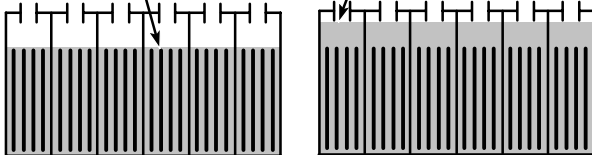

FIG. 75

⚠ WARNING: Fire Or Explosion Hazard. Batteries Emit Hydrogen Gas. Keep Sparks And Open Flame Away. Keep Battery Compartment Open When Charging.

2. Clean the batteries to prevent battery corrosion. Use a scrub brush with a mixture of baking soda and water (Figure 76).

FOR SAFETY: When cleaning batteries, wear protective gloves and eye protection. Avoid contact with battery acid.



FIG. 76

SQUEEGEE BLADES

When the blades become worn, simply rotate the blades end-for-end or top-to-bottom to a new wiping edge. Replace blades when all edges are worn.

The front blades on the 700mm/800mm squeegee assemblies have 12/14 slots on one edge and 6 slots on the opposite edge (Figure 77). If making sharp turns with the cylindrical brush models use the 12/14 slotted edge for maximum water pickup.

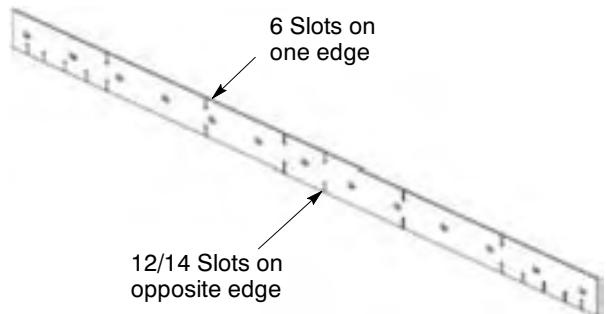

FIG. 77

Replacing Squeegee Blades:

1. Loosen the band clamp and remove the band from the squeegee assembly (Figure 78).

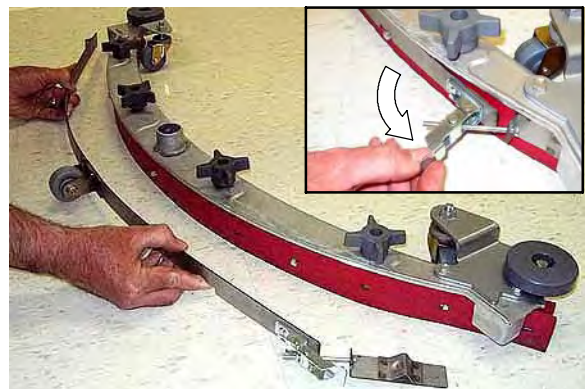

FIG. 78

T5 –Maintenance

(Page 10 of 15)

2. Replace or rotate the rear blade to a new wiping edge and replace band (Figure 79).

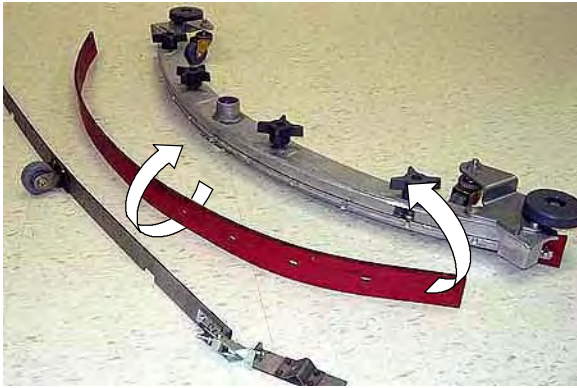

FIG. 79

3. To change the front blade, remove the band and loosen the four knobs. Replace or rotate the front blade to a new wiping edge (Figure 80)

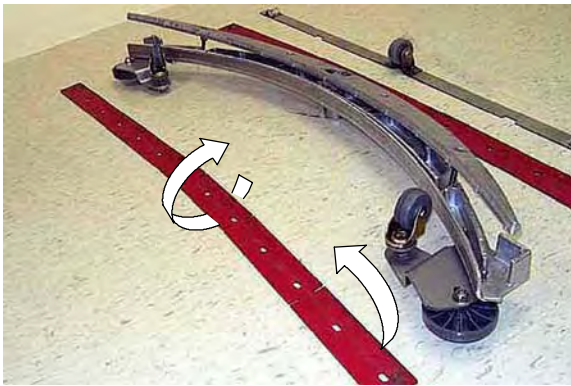

FIG. 80

MOTOR MAINTENANCE

Contact an Authorized Tennant Service Center for carbon brush replacement.

Carbon Brush Replacement	Hours
Drive Transaxle Motor	750
Vacuum Motor	
Disk Brush Motors	
Cylindrical Brush Motors	1000

⚠ WARNING: Electrical Hazard. Disconnect Battery Cables Before Servicing Machine.

FaST SYSTEM MAINTENANCE

Every 1000 hours replace the orifice plate and filter screen located inside the detergent injector assembly. Order service kit p/n 9001489.

1. To access the detergent injector assembly, lower the scrub head and remove the front shroud (Figure 81)

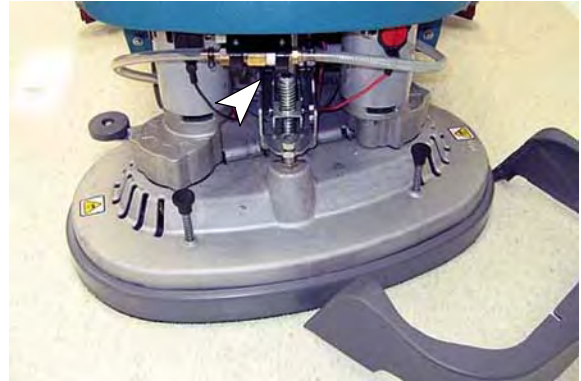

FIG. 81

2. Remove the injector assembly from clamps (Figure 82).



FIG. 82

3. Unthread the black plastic filter housing and replace the orifice plate and filter (Figure 83).

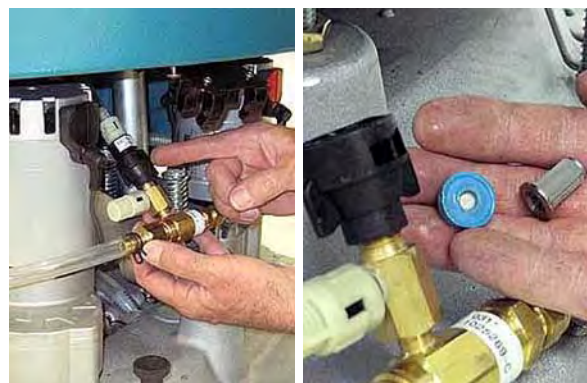

FIG. 83

T5 –Maintenance

(Page 11 of 15)

JACKING UP MACHINE

Use the designated locations to jack up the machine for service (Figure 84). Empty the recovery and solution tank and position the machine on a level before jacking.

FOR SAFETY: When servicing machine, jack machine up at designated locations only. Use jack or hoist that will support machine weight.

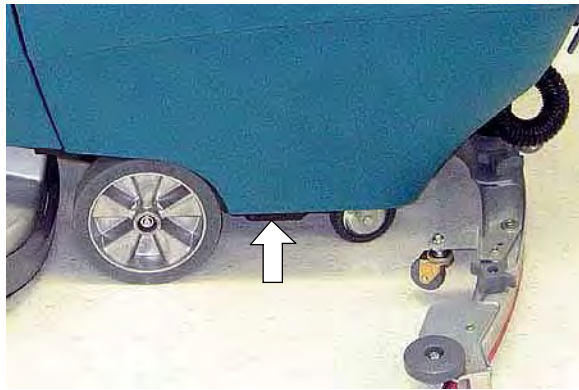

FIG. 84

TRANSPORTING MACHINE

When transporting the machine by trailer or truck, be certain to follow the transporting procedure below:

1. Drain machine tanks.
2. Load the machine using a ramp that can support the machine weight and person loading it. The maximum ramp incline should not exceed 11° at a ramp length of 3.7m (12 ft).
3. Position the front of machine up against the front of the trailer or truck. Lower the scrub head and squeegee.
4. Set the parking brake, if equipped, and place a block behind each wheel to prevent the machine from rolling.
5. Secure with tie-down straps as shown (Figure 85). It may be necessary to install tie-down brackets to trailer or truck.

FOR SAFETY: When loading/unloading machine onto/off truck or trailer, use a ramp that can support the machine weight and person loading it, do not exceed a 11° ramp incline at a ramp length of 3.7m (12 ft), use tie-down straps to secure machine and block machine wheels.

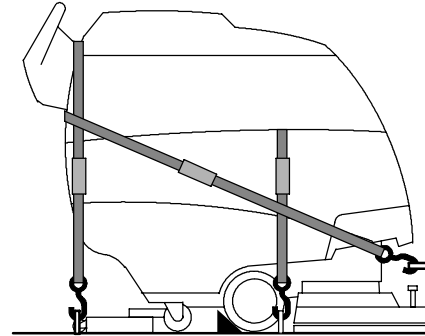

FIG. 85

STORING MACHINE

1. Charge the batteries before storing machine to prolong the life of the batteries.
2. Drain and rinse the tanks thoroughly.
3. Store the machine in a dry area with the squeegee and scrub head in the up position.
4. Open the recovery tank cover to promote air circulation.

ATTENTION: Do not expose machine to rain, store indoors.

5. If storing machine in freezing temperatures, make sure to drain machine of all water.

For models equipped with the FaST System, follow the FaST SYSTEM FREEZE PROTECTION procedure below.

FaST SYSTEM FREEZE PROTECTION

Valve Coupling #1002856 and 15 cm Hose #63182 are required (Purchased separately).

1. Remove the FaST-PAK carton and connect the valve coupling and 15cm hose (purchased parts) to the supply hose (Figure 86).

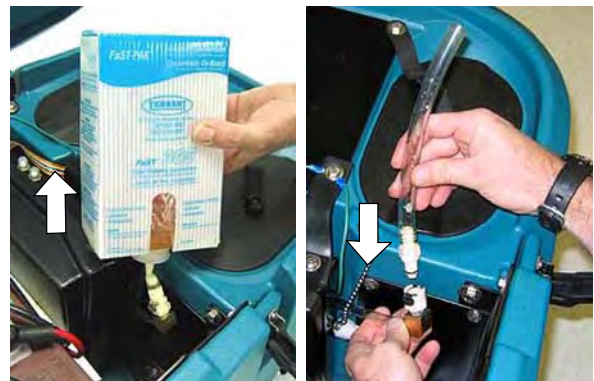

FIG. 86



T5 –Maintenance

(Page 12 of 15)

2. Disconnect the opposite end of the supply hose from the injector assembly and drain the supply hose (Figure 87). To access the injector assembly remove the front shroud.

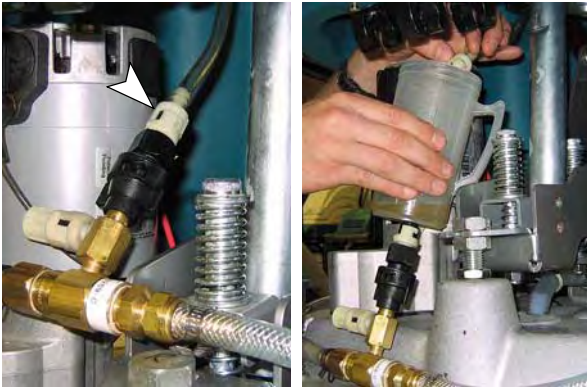

FIG. 87

3. Reconnect the supply hose to injector assembly and pour a recreational vehicle (RV) anti-freeze into the supply hose until full (Figure 88).



FIG. 88

4. Operate the FaST system as normal until the foaming stops. This step could take anywhere from 5-10 minutes.
5. Remove the valve coupling and connect the storage plug (Figure 89).



FIG. 89

6. Drain the recovery and solution tanks and store machine.

7. To drain the anti-freeze, repeat the draining process above and reconnect the supply hose to the FaST-PAK carton.

RECOMMENDED STOCK ITEMS

Refer to the Parts List Manual for recommended stock items. Stock Items are clearly identified with a bullet preceding the parts description. See example below:

26	1017380	(00000000-)	• Hose, Drain, Assy, 1.5d X 20.5, Blk, Flt
27	1026639	(00000000-)	• Hose, Drain, Assy
28	1019569	(00000000-)	• Strap, Drain Cap
29	1008637	(00000000-)	• O Ring, 1.49" Id, 1.76" Od

M

T5 –Maintenance

(Page 13 of 15)

TROUBLESHOOTING

PROBLEM	CAUSE	SOLUTION
Machine will not operate	Discharged batteries	Charge batteries
	Emergency-stop button activated	Turn button clockwise to reset
	Faulty battery(s)	Replace battery(s)
	Loose battery cable	Tighten loose cable
	Faulty control board	Contact Tennant Service 1-800-553-8033
	Faulty key switch	Contact Tennant Service 1-800-553-8033
	Machine fault detected.	See Control Panel Fault Indicator Codes
Onboard battery charger will not operate	Plug not connected to power supply	Check plug connection
	Faulty charger fuse	Replace charger fuse
	Faulty power supply cord	Replace cord
	Error detected.	See On-board Battery Charger Error Codes
Brush motor(s) will not operate	1-STEP scrub button is off	Turn on the 1-STEP scrub button
	Brush motor overload	See Control Panel Fault Indicator Codes
	Discharged batteries	Charge batteries
	Faulty control board	Contact Tennant Service 1-800-553-8033
	Faulty scrub head (up/down) switch	Contact Tennant Service 1-800-553-8033
	Faulty control handle bail switch	Contact Tennant Service 1-800-553-8033
	Faulty brush motor or wiring	Contact Tennant Service 1-800-553-8033
	Worn carbon brushes	Contact Tennant Service 1-800-553-8033
	Broken or loose belt (cylindrical brush model)	Replace or tighten belt
Machine will not propel	Parking brake is set	Release parking brake lever
	Machine fault detected	See Control Panel Fault Indicator Codes
	Faulty control board	Contact Tennant Service 1-800-553-8033
	Wheels raised off floor	Contact Tennant Service 1-800-553-8033
	Faulty transaxle motor or wiring	Contact Tennant Service 1-800-553-8033
	Worn carbon brushes	Contact Tennant Service 1-800-553-8033
	Exceeded maximum incline	Avoid steep inclines and reset key
Vacuum motor will not operate	Squeegee is raised off floor	Lower squeegee
	Discharged batteries	Charge batteries
	Faulty control board	Contact Tennant Service 1-800-553-8033
	Faulty vacuum motor or wiring	Contact Tennant Service 1-800-553-8033
	Worn carbon brushes	Contact Tennant Service 1-800-553-8033
Little or no solution flow	Solution tank is empty	Fill solution tank
	Clogged solution tank filter	Clean solution tank filter
	Discharged batteries	Charge batteries
	Clogged solution valve	Remove valve and clean
	Faulty control board	Contact Tennant Service 1-800-553-8033



T5 –Maintenance

(Page 14 of 15)

TROUBLESHOOTING - Continued

PROBLEM	CAUSE	SOLUTION
Poor water pickup	Recovery tank is full or excessive foam buildup	Drain recovery tank
	Loose drain hose cap	Tighten cap
	Clogged float shut-off screen located in recovery tank	Clean screen
	Clogged squeegee assembly	Clean squeegee assembly
	Worn squeegee blades	Replace or rotate squeegee blades
	Incorrect Squeegee blade deflection	Adjust Squeegee blade height
	Loose vacuum hose connections	Secure hose connections
	Clogged vacuum hose	Remove clogged debris
	Damaged vacuum hose	Replace vacuum hose
	Recovery tank cover not in place	Properly position cover
	Damaged recovery tank cover seal	Replace seal
	Faulty vacuum motor	Contact Tennant Service 1-800-553-8033
Poor scrubbing performance	Debris caught in brush	Remove debris
	Worn brushes/pads	Replace brushes/pads
	Incorrect brush pressure setting	Adjust pressure setting
	Wrong brush/pad type.	Use correct brush/pad
Reduced run time	Batteries not fully charged	Fully recharge batteries
	Defective batteries	Replace battery
	Batteries need maintenance	See BATTERY MAINTENANCE
	Faulty battery charger	Repair or replace battery charger
Solution flow and brush pressure buttons and FaST system switch are locked	Supervisor controls are activated (lock-out feature)	Contact your Supervisor
FaST Model: FaST System does not operate or operate correctly	FaST system switch is not turned on	Turn on FaST system switch
	FaST-PAK supply hose not connected	Connect supply hose
	Clogged FaST-PAK supply hose or connectors	Soak in warm water to unclog
	Empty FaST-PAK carton	Replace FaST-PAK carton
	Kink in FaST-PAK supply hose	Undo hose kink
	Clogged FaST solution system	Contact Tennant Service 1-800-553-8033
	Faulty FaST system on/off switch	Contact Tennant Service 1-800-553-8033
	Faulty pump	Contact Tennant Service 1-800-553-8033
	Clogged solution tank filter	Drain solution tank. remove solution tank filter, clean and reinstall
	Clogged detergent orifice/filter screen	Replace orifice/filter screen (See FaST SYSTEM MAINTENANCE)
	Clogged FaST solution inlet filter	Contact Tennant Service 1-800-553-8033
Faulty control board	Contact Tennant Service 1-800-553-8033	



T5 –Maintenance

(Page 15 of 15)

CONTROL PANEL FAULT INDICATOR CODES

The control panel fault indicator lights will display the following codes when the machine detects a fault.

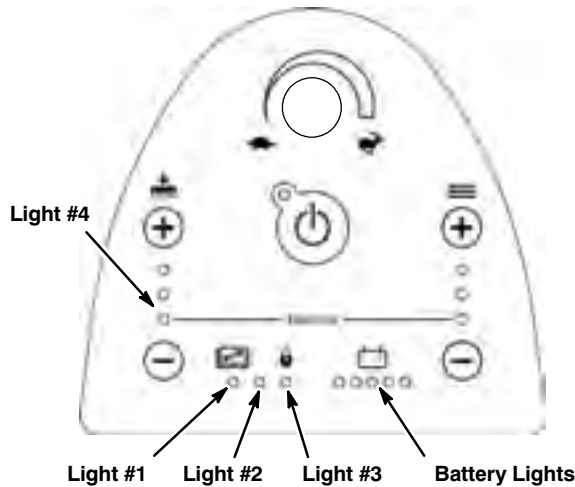

CODE	FAULT	SOLUTION
Light #1 blinks	Recovery tank is raised.	Lower recovery tank. Restart key to reset.
Lights #1, #2 and #3 ripple	Battery charger connected.	Disconnect battery charger. Restart key to reset.
Lights #1 and #4 blink	Left Brush motor overload.	Inspect brush for entangled debris, improper pad or contact service center. Restart key to reset.
Lights #3 and #4 blink	Right Brush motor overload.	Inspect brush for entangled debris, improper pad or contact service center. Restart key to reset.
Lights #2 and #3 blink	Propel motor overload. Exceeded maximum incline.	Avoid steep inclines or contact service center. Restart key to reset.
Lights #1 and #3 blink	Scrub head movement is obstructed or actuator motor malfunction.	Check scrub head for obstruction or contact service center. Restart key to reset.
Light #2 blinks	Vacuum motor malfunction.	Contact Tennant Service 1-800-553-8033
Lights #1 and #2 blink	Propel throttle malfunction.	Contact Tennant Service 1-800-553-8033
Light #3 blinks	FaST pump overload or malfunction.	Reset the 10A circuit breaker or contact service center. Restart key to reset.
Light #3 blinks when pressing the solution flow, brush pressure buttons and FaST system switch	Supervisor controls activated (lockout feature)	Contact your Supervisor.
Lights #1, #2 and #3 blink	Wand Pump overload or malfunction.	Reset the 10A circuit breaker button or contact service center. Restart key to reset.
All battery lights blink	Emergency-Stop button activated	Turn button clockwise to reset.
All battery lights ripple	Key turned on while bail was engaged.	Release the control handle start bail.



T5 –Electrical Schematic

(Page 1 of 2)

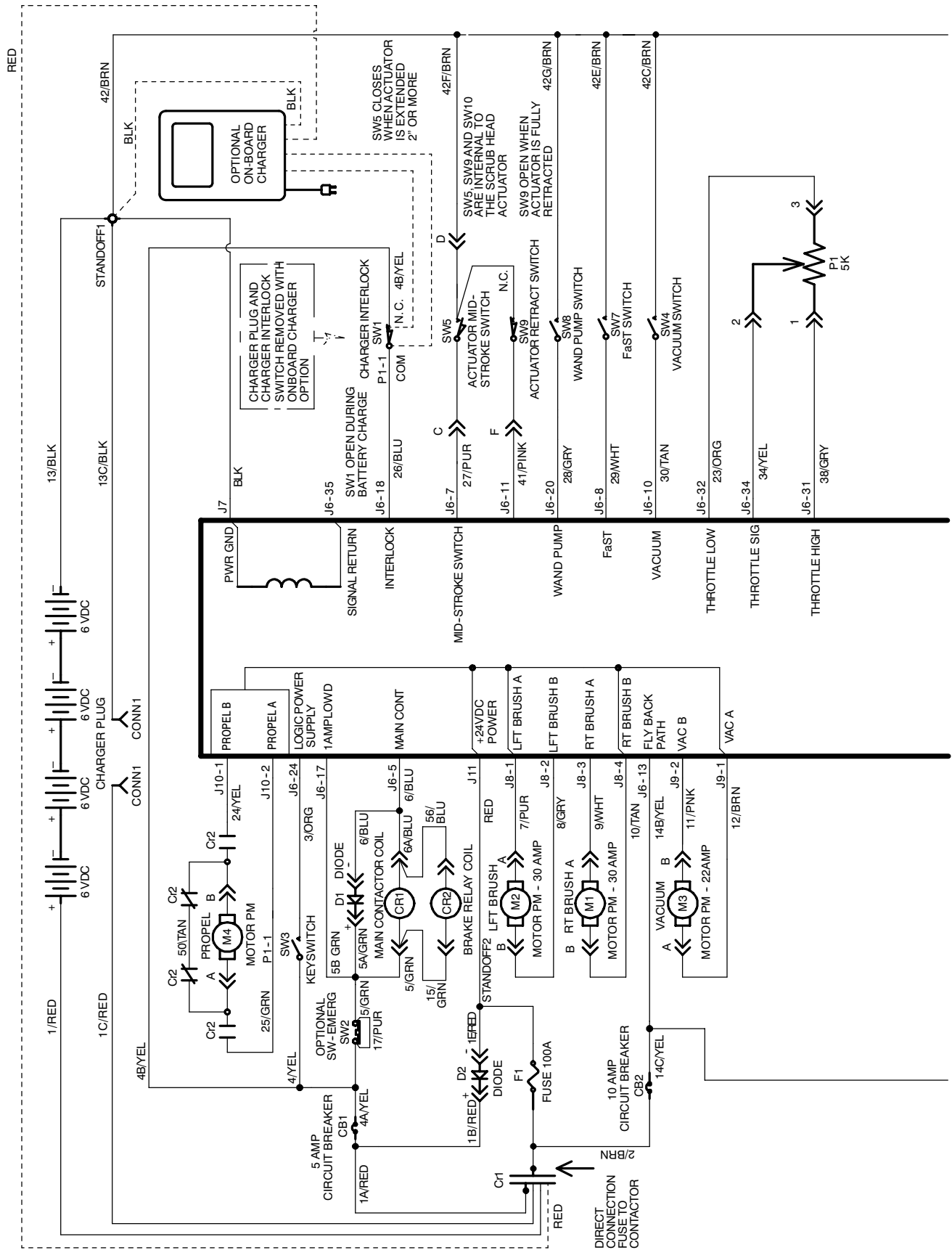

T5 –Electrical Schematic

(Page 2 of 2)

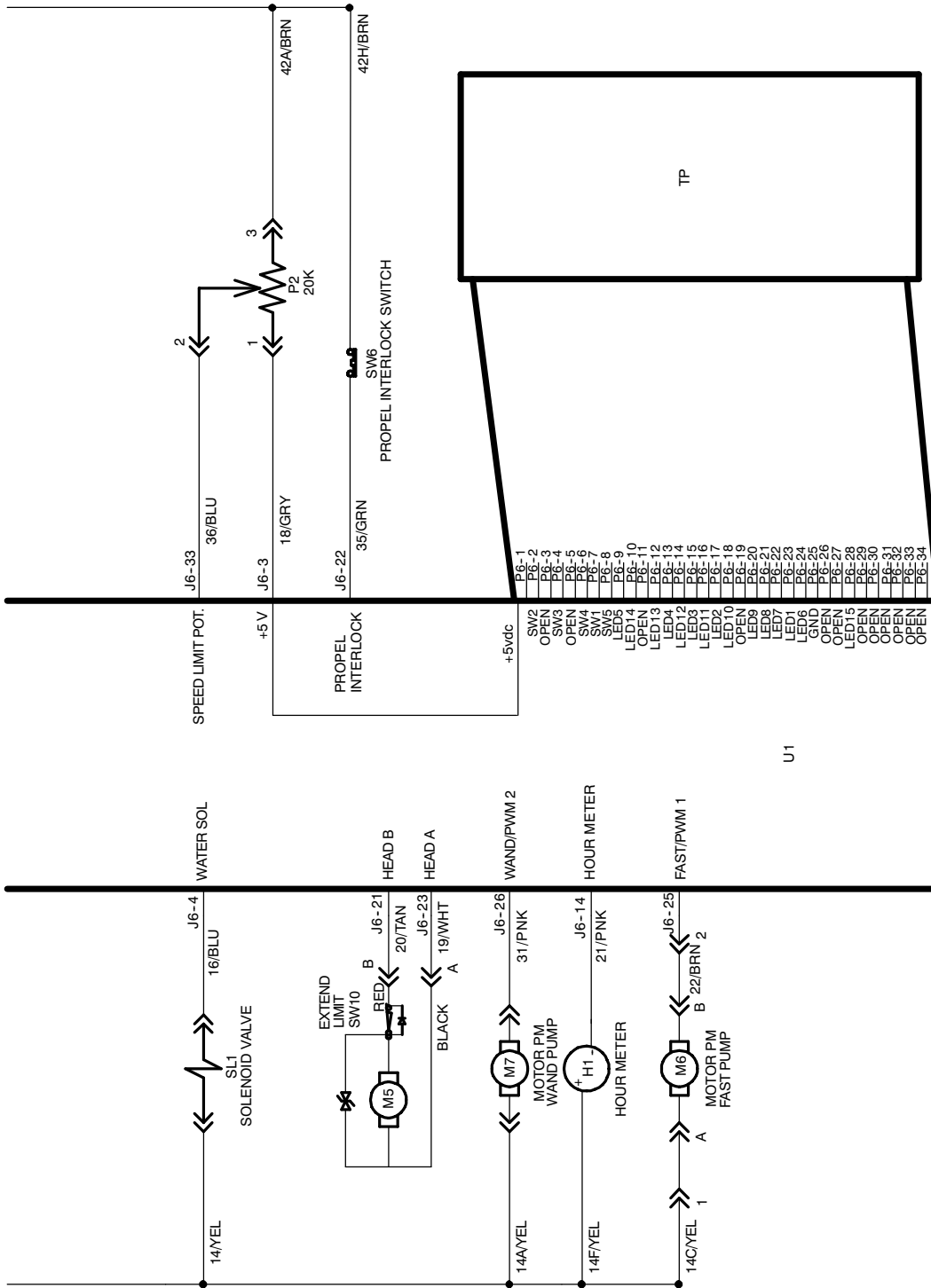

LEGEND

- | | | | | | |
|------|---|-------------------------------|------|---|-----------------------------------|
| CB1 | = | CIRCUIT BREAKER 5A #383720 | SW3 | = | SWITCH KEY #1011402 |
| CB2 | = | CIRCUIT BREAKER 10A #383721 | SW4 | = | SWITCH VACUUM #1012568 |
| CR1 | = | MAIN CONTACTOR COIL #1011086 | SW5 | = | SWITCH ACTUATOR MID STROKE |
| CR2 | = | BRAKE RELAY COIL #1001219 | SW6 | = | SWITCH PROPEL INTERLOCK #606292AM |
| C-r1 | = | CONTACT RELAY #1011086 | SW7 | = | SWITCH FAST #130787 |
| C-r2 | = | CONTACT RELAY #1001219 | SW8 | = | SWITCH WAND PUMP #130787 |
| D1 | = | DIODE #222290 | SW9 | = | SWITCH ACTUATOR RETRACT |
| D2 | = | DIODE #222290 | SW10 | = | SWITCH ACTUATOR EXTEND |
| F1 | = | FUSE 100A #86379 | TP | = | TOUCH PANEL #1020677 |
| H1 | = | HOUR METER #1011282 | U1 | = | CIRCUIT BOARD #1022812 |
| M1 | = | MOTOR BRUSH RT | | | |
| M2 | = | MOTOR BRUSH LFT | | | |
| M3 | = | MOTOR VACUUM FAN | | | |
| M4 | = | MOTOR DRIVE | | | |
| M5 | = | MOTOR SCRUB HEAD ACTUATOR | | | |
| M6 | = | MOTOR PUMP FAST | | | |
| M7 | = | MOTOR PUMP WAND | | | |
| P1 | = | POTENTIOMETER 5K #1021853 | | | |
| P2 | = | POTENTIOMETER 20K #1022706 | | | |
| SL1 | = | SOLENOID VALVE #1013599 | | | |
| SW1 | = | SWITCH SAFETY CHARGER #611005 | | | |
| SW2 | = | SWITCH E-STOP #1011735 | | | |



T5 –Wiring Harness Detail

(Page 1 of 6)

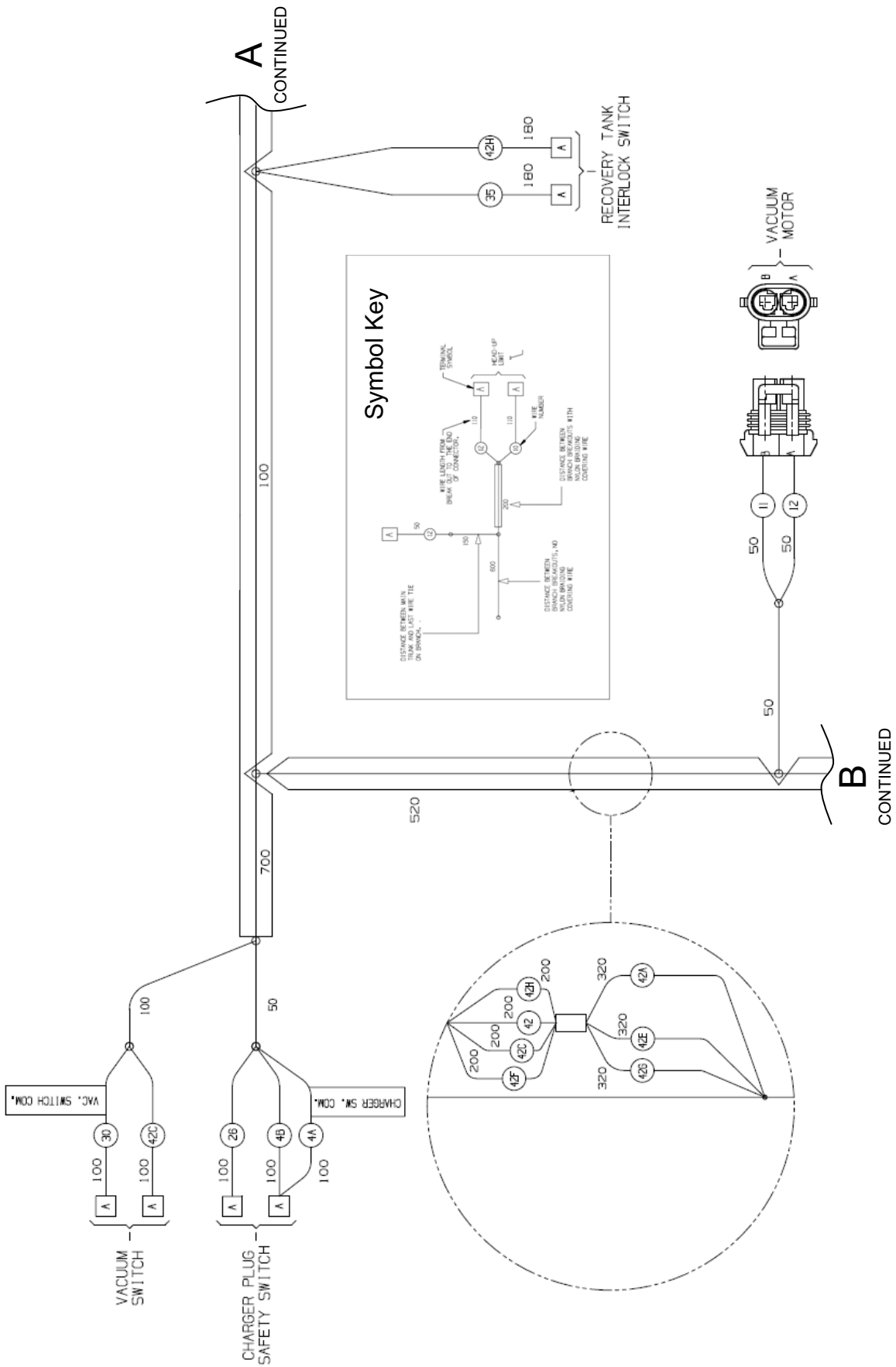

T5 –Wiring Harness Detail

(Page 2 of 6)

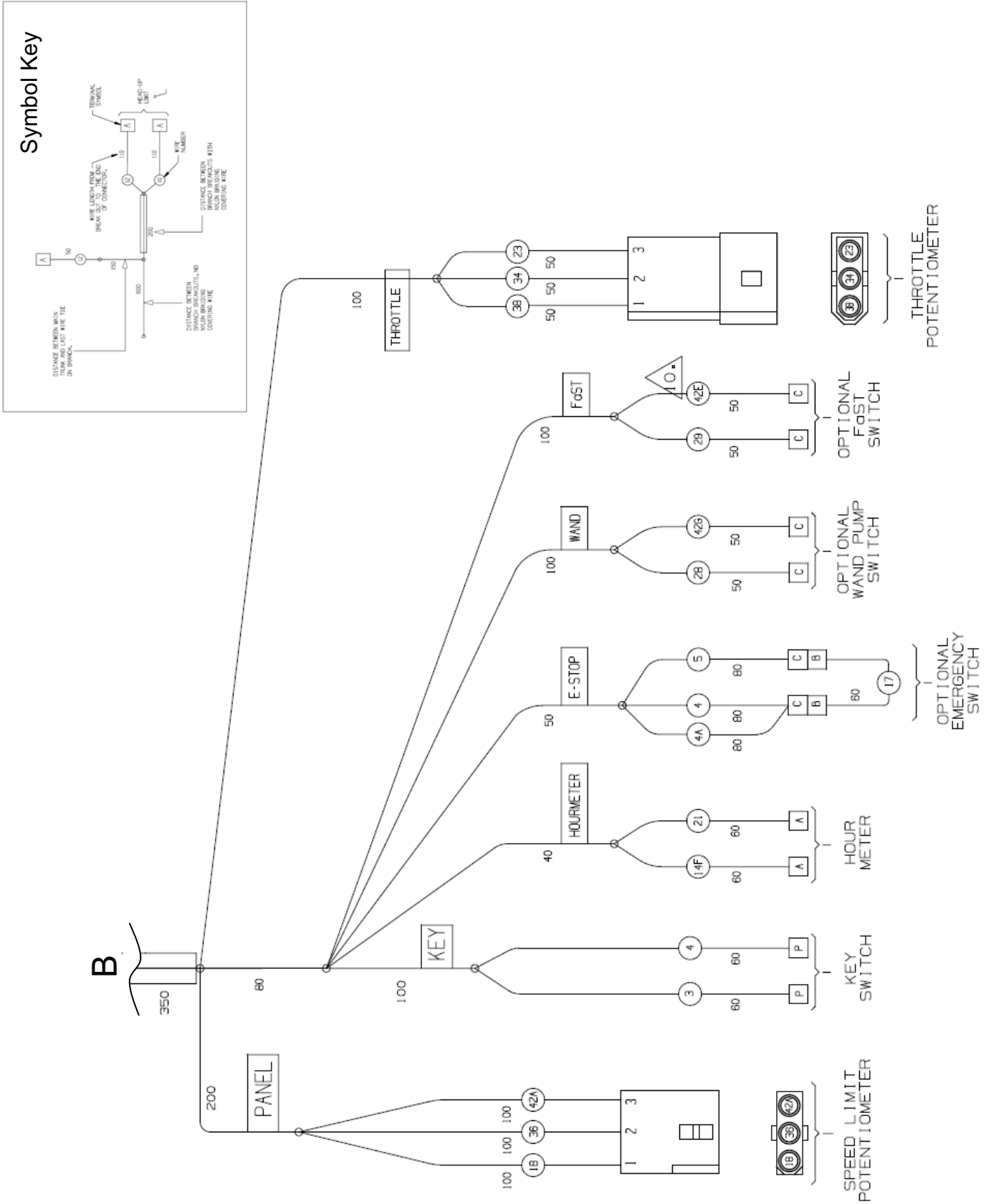

T5 –Wiring Harness Detail

(Page 3 of 6)

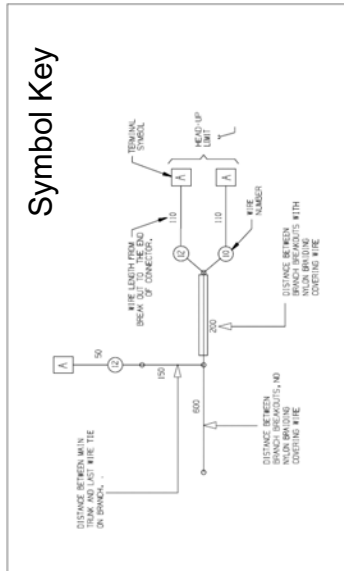
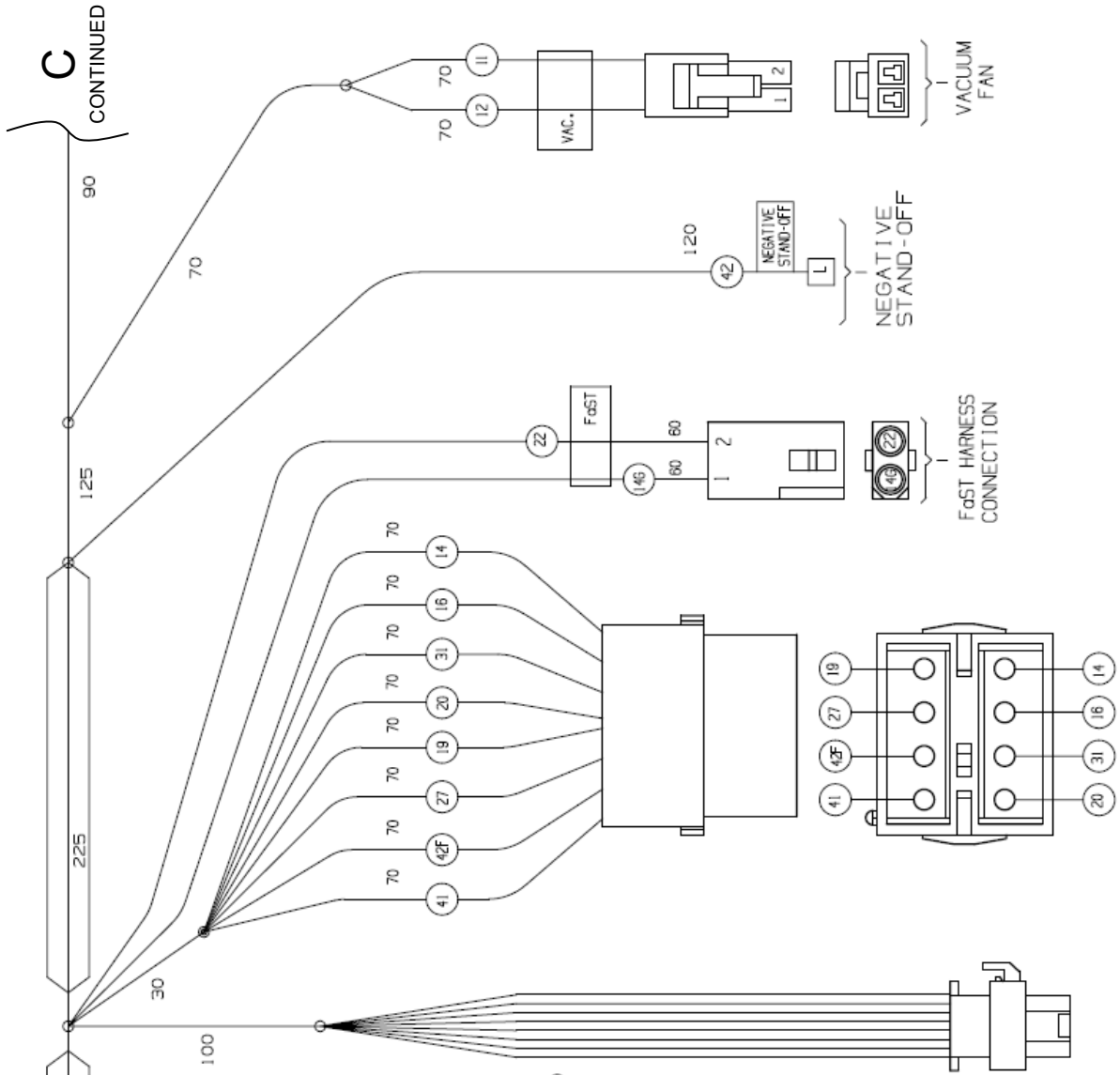

T5 –Wiring Harness Detail

(Page 4 of 6)

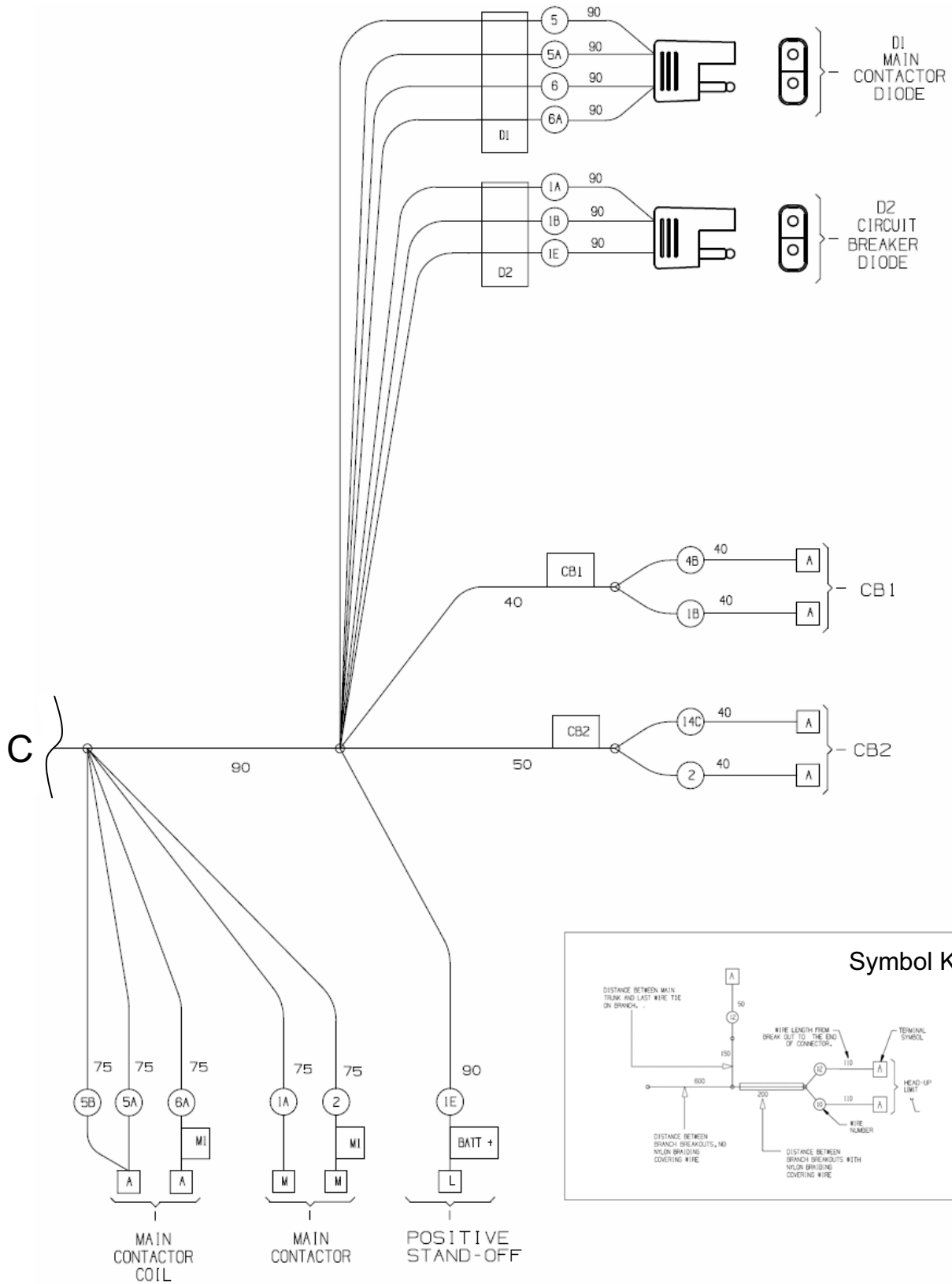

T5 –Wiring Harness Detail

(Page 5 of 6)

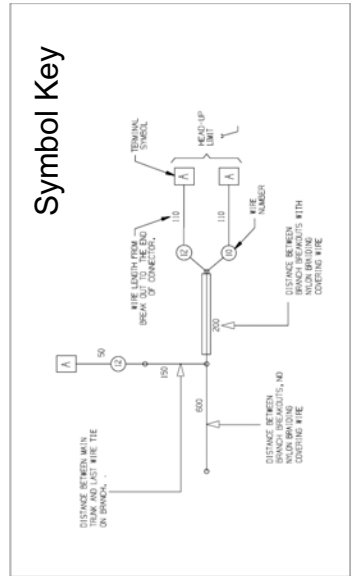
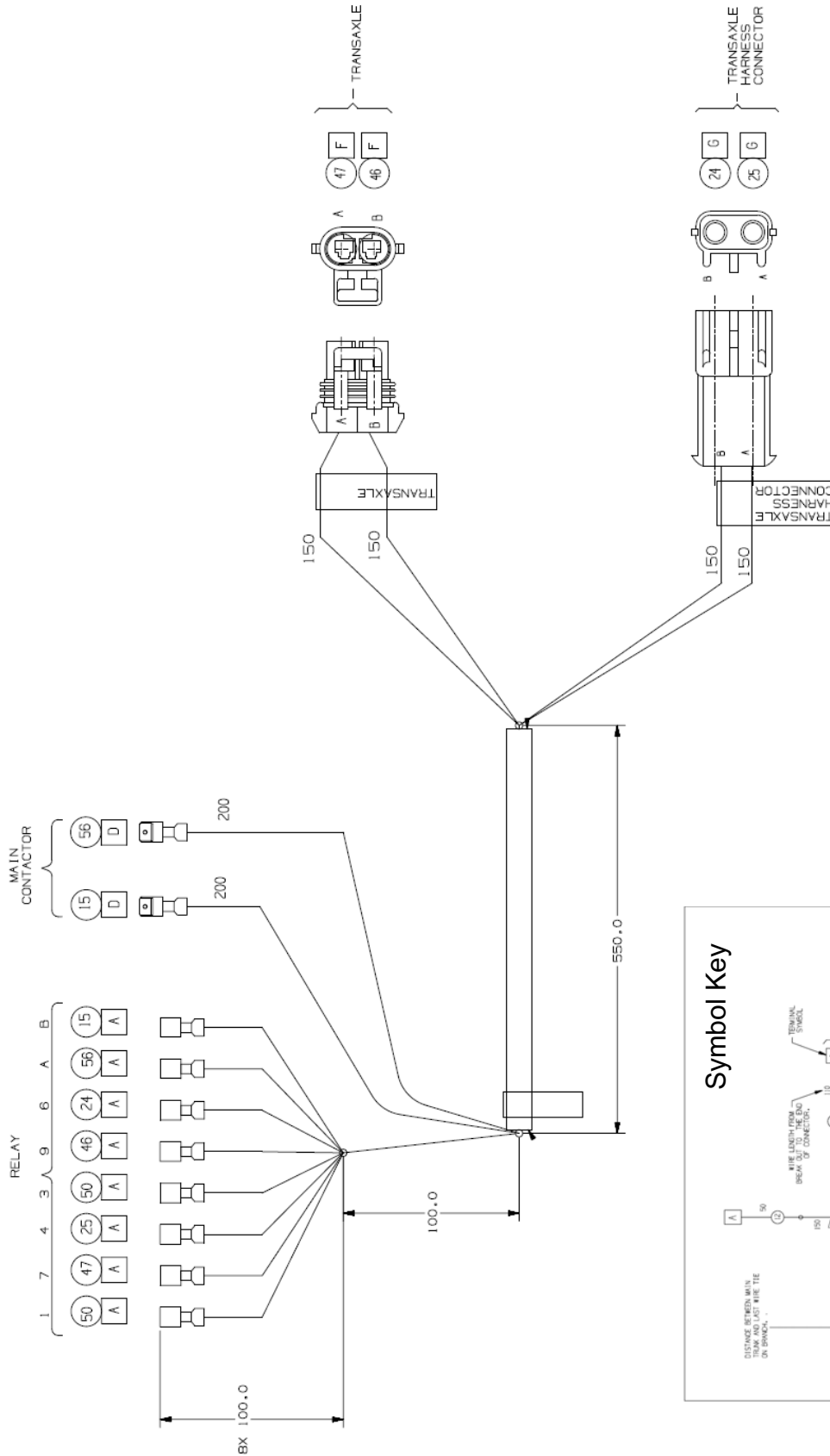

T5 –Wiring Harness Detail

(Page 6 of 6)

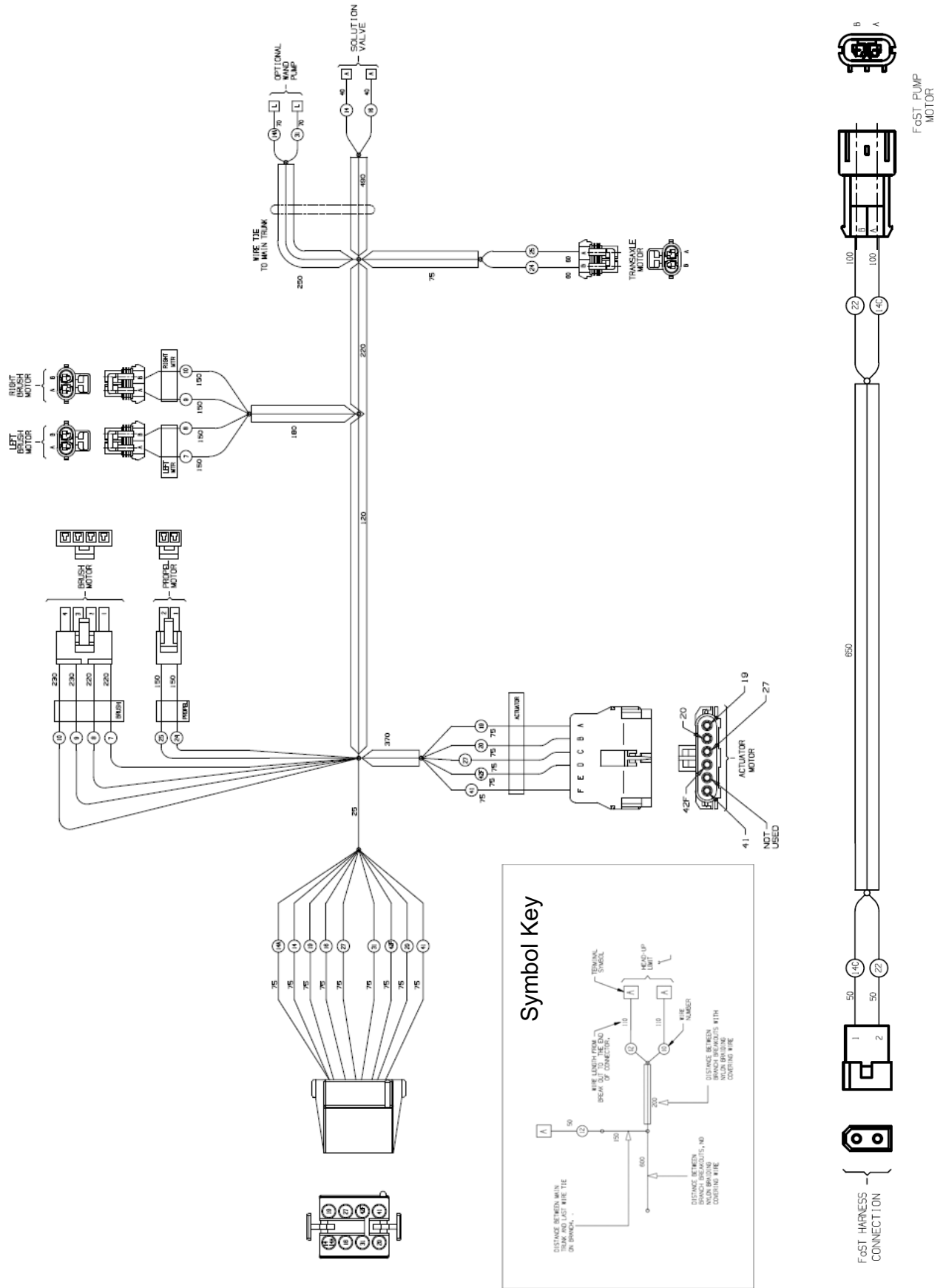

T5 – Main Harness to Control Board 35 Pin Connector Detail

pin #	wire #	input or output	active voltage	inactive voltage	function/component controlled
1	empty	x	x	x	x
2	empty	x	x	x	x
3	18	output	5v	x	P2 Speed limit sensor sensor logic high
4	16	output	B-	B+	SL1 Conventional solenoid valve
5	6	output	B-	B+	CR1 Main contactor
6	empty	x	x	x	x
7	27	input	B-	open	SW5 Actuator mid-stroke switch
8	29	input	B-	open	SW7 FaST pump switch
9	empty	x	x	x	x
10	30	input	B-	open	SW4 Vacuum fan switch
11	41	input	open	B-	SW9 Actuator retract switch
12	empty	x	x	x	x
13	14B	input	B+	open	Fly back path
14	21	output	B-	B+	H1 Hour meter
15	empty	x	x	x	x
16	empty	x	x	x	x
17	5B	input	B+	open	Battery positive power supply
18	26	input	open	B+	SW1 Battery charger interlock switch
19	empty	x	x	x	x
20	28	input	B-	open	SW8 Wand pump switch
21	20	output	B+ or B-	open	M5 Scrub head actuator
22	35	input	B-	open	SW6 Recovery tank interlock switch
23	19	output	B+ or B-	open	M5 Scrub head actuator
24	3	input	B+	open	Battery positive power supply
25	22	output	B-	B+	M6 FaST pump motor
26	31	output	B-	B+	M7 Wand pump motor
27	empty	x	x	x	x
28	empty	x	x	x	x
29	empty	x	x	x	x
30	empty	x	x	x	x
31	38	output	5v	x	P1 Throttle position sensor logic high
32	23	output	0v	x	P1 Throttle position sensor logic low
33	36	input	0v to 5v	x	P2 Speed limit sensor logic input
34	34	input	0v to 2.4v & 2.6v to 5v	2.4v to 2.6v	P1 Throttle position sensor logic input
35	empty	x	x	x	x



Wiring Color Codes
(Unless otherwise marked)

Right Most Digit of Wire Number	Color of Wire
0	Tan
1	Pink
2	Brown
3	Orange
4	Yellow
5	Green
6	Blue
7	Purple
8	Gray
9	White

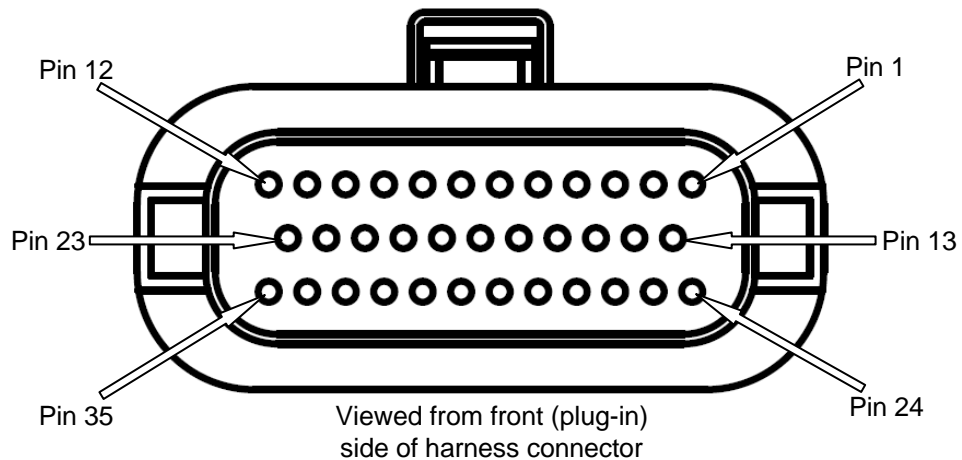

T5 – Control Panel LED Details

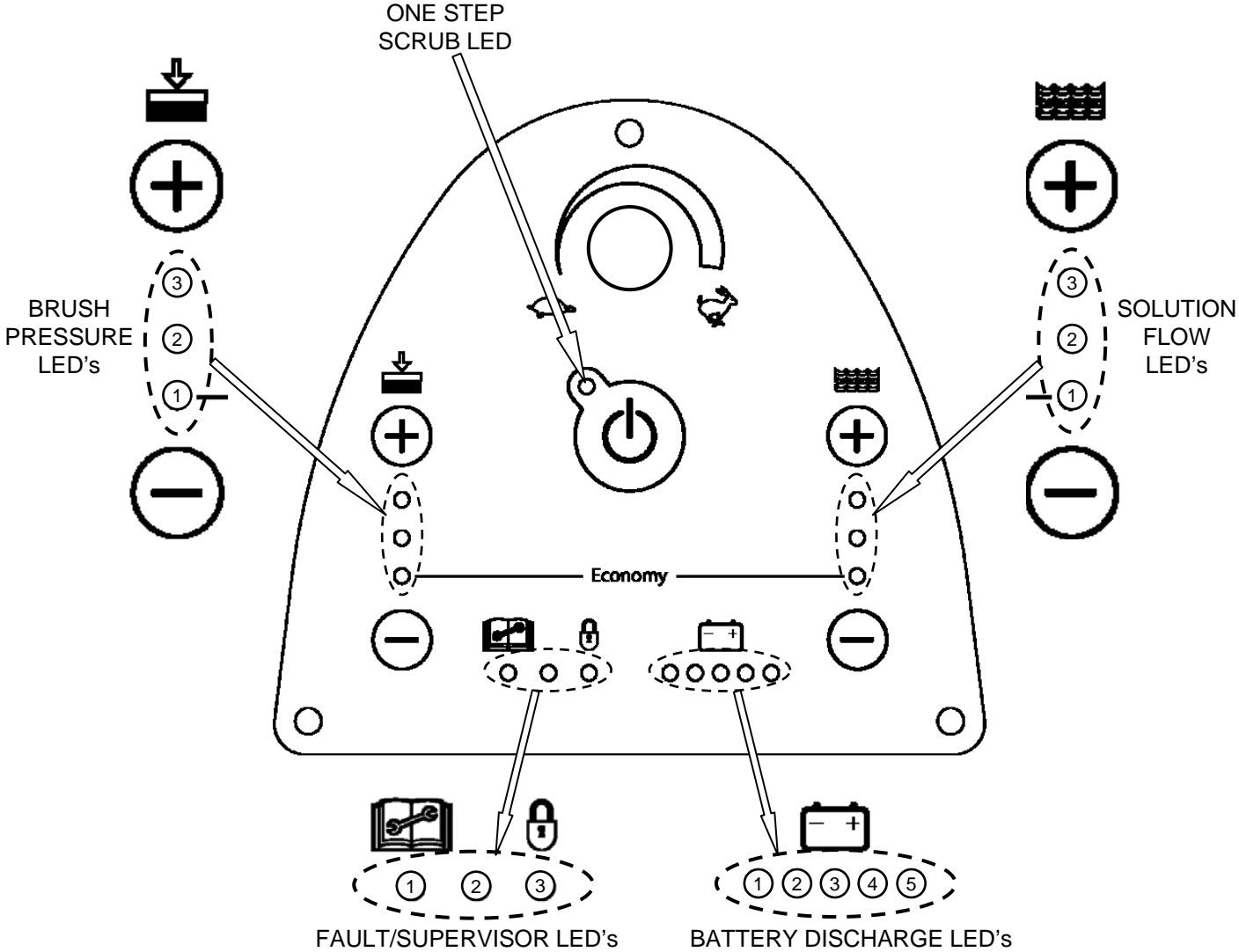

LED #	COLOR
1	RED
2	YELLOW
3	GREEN
4	GREEN
5	GREEN



Commonly Used Electrical Symbols & Terms

NOTE: The term "NORMALLY" refers to the components' "at rest" or "de-energized" position

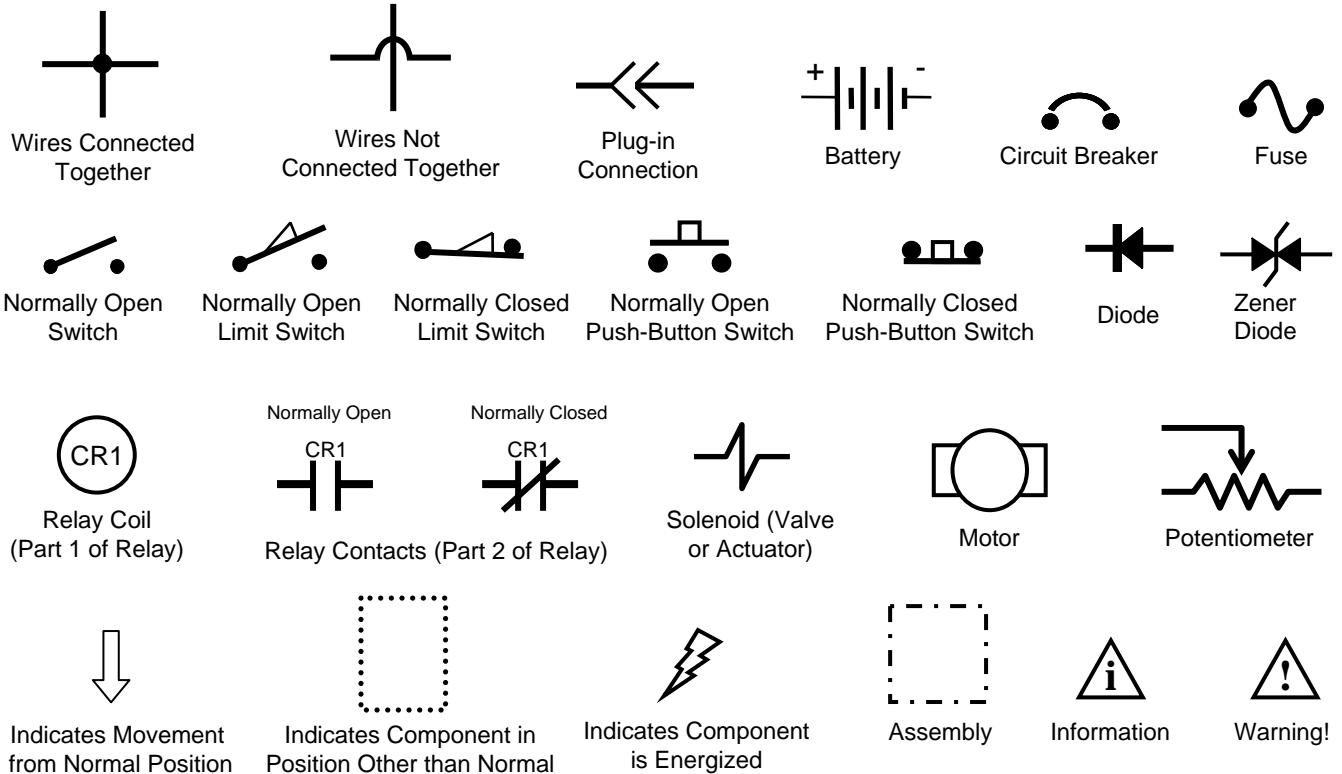

Terms & Abbreviations

BDI – Battery Discharge Indicator

LED – Light Emitting Diode

PM – Permanent Magnet

PWM (Pulse Width Modulation) – A method of using controlled on/off times to regulate voltage and current to an electrical device

Standoff – A common connecting point for multiple wires

Zener Diode – A device used in an electrical circuit to prevent high voltage spikes

Example of Wiring Numbers & Colors:

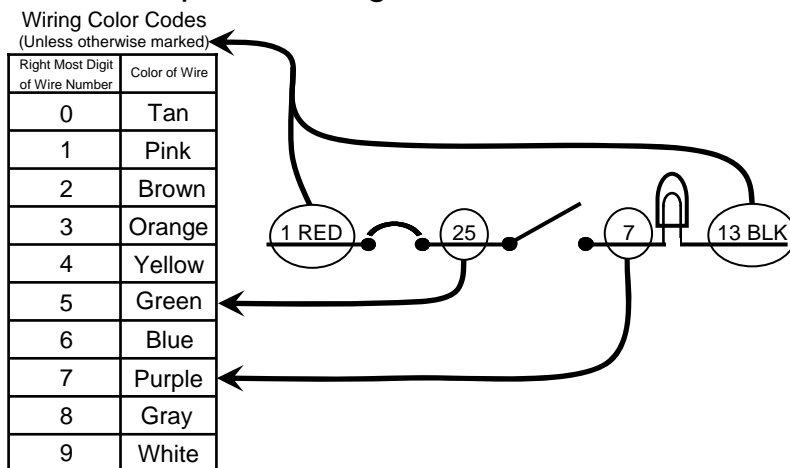

T5 - Key OFF Power Distribution (With Standard Off-Board Battery Charger)

CONDITIONS: Key OFF, off-board battery charger **NOT CONNECTED** to charger plug

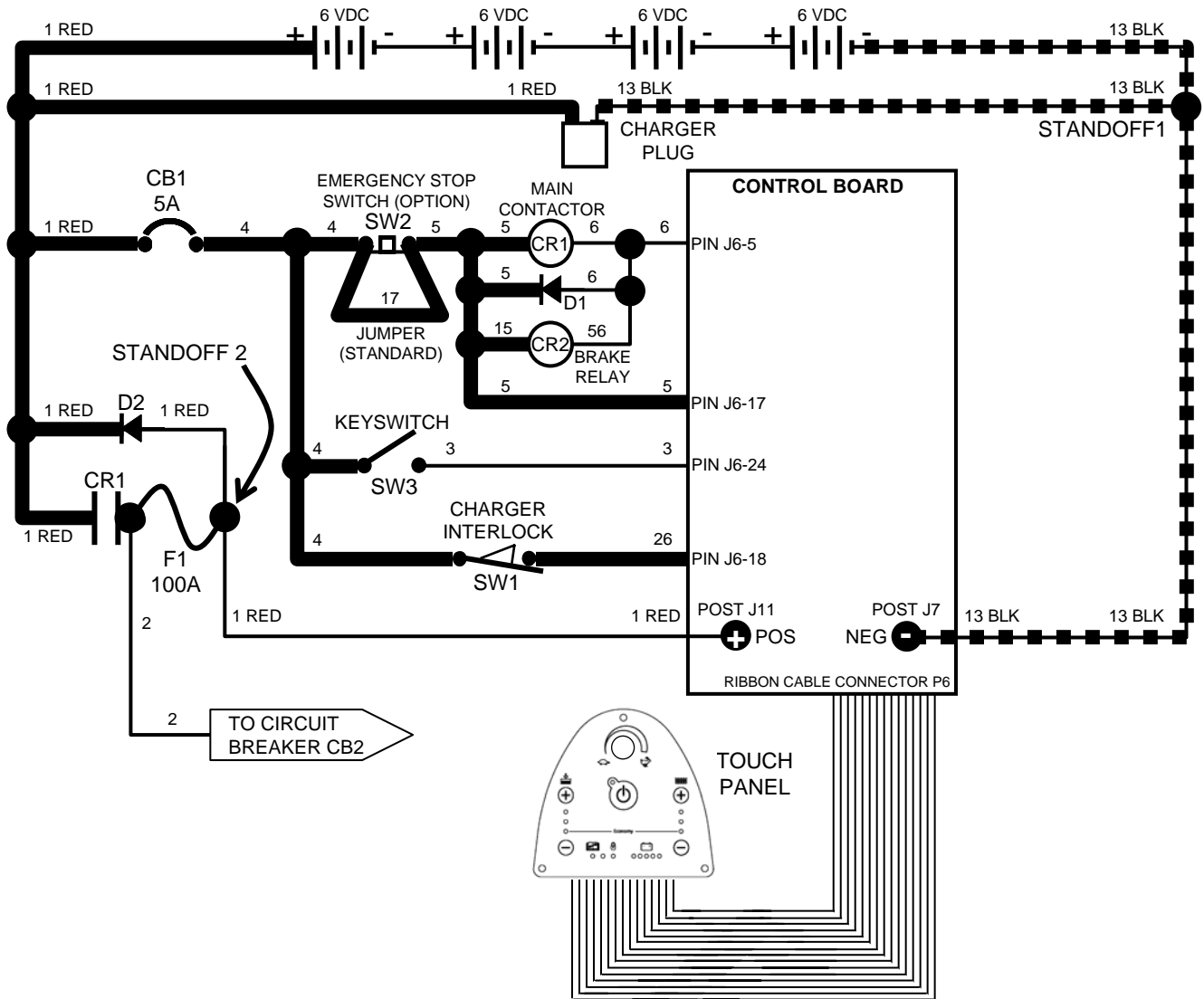

Wiring Color Codes
(Unless otherwise marked)

Right Most Digit of Wire Number	Color of Wire
0	Tan
1	Pink
2	Brown
3	Orange
4	Yellow
5	Green
6	Blue
7	Purple
8	Gray
9	White

--- = Battery Negative or Logic Ground

— = Battery Positive or Logic High

! Be cautious when working near Control Board - *Battery voltage is always present, even with Key OFF*

i If Charger Plug is connected to battery charger, ALL machine functions will be disabled when Key Switch is turned ON

i If machine is not equipped with optional Emergency Stop Switch, jumper wire 17/Purple will replace SW2



T5 - Key OFF Power Distribution (With Standard Off-Board Battery Charger)

CONDITIONS: Key OFF, off-board battery charger **CONNECTED** to charger plug

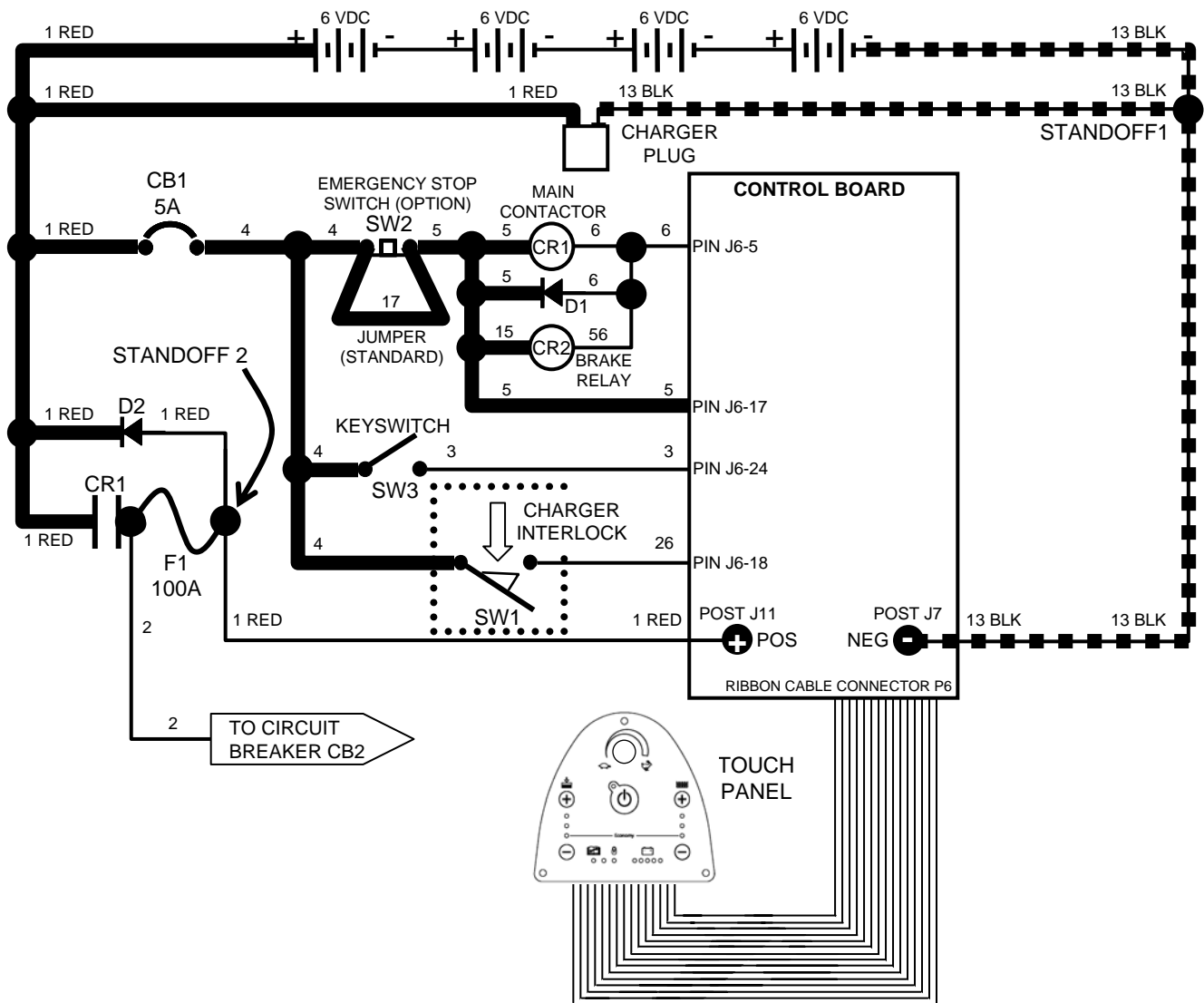

Wiring Color Codes
(Unless otherwise marked)

Right Most Digit of Wire Number	Color of Wire
0	Tan
1	Pink
2	Brown
3	Orange
4	Yellow
5	Green
6	Blue
7	Purple
8	Gray
9	White

--- = Battery Negative or Logic Ground

— = Battery Positive or Logic High

 **Be cautious when working near Control Board - Battery voltage is always present, even with Key OFF**

 **If Charger Plug is connected to battery charger, ALL machine functions will be disabled when Key Switch is turned ON**

 **If machine is not equipped with optional Emergency Stop Switch, jumper wire 17/Purple will replace SW2**

T5 - Key OFF Power Distribution (With Optional On-Board Battery Charger)

CONDITIONS: Key OFF, On-Board battery charger **NOT** CONNECTED to AC power

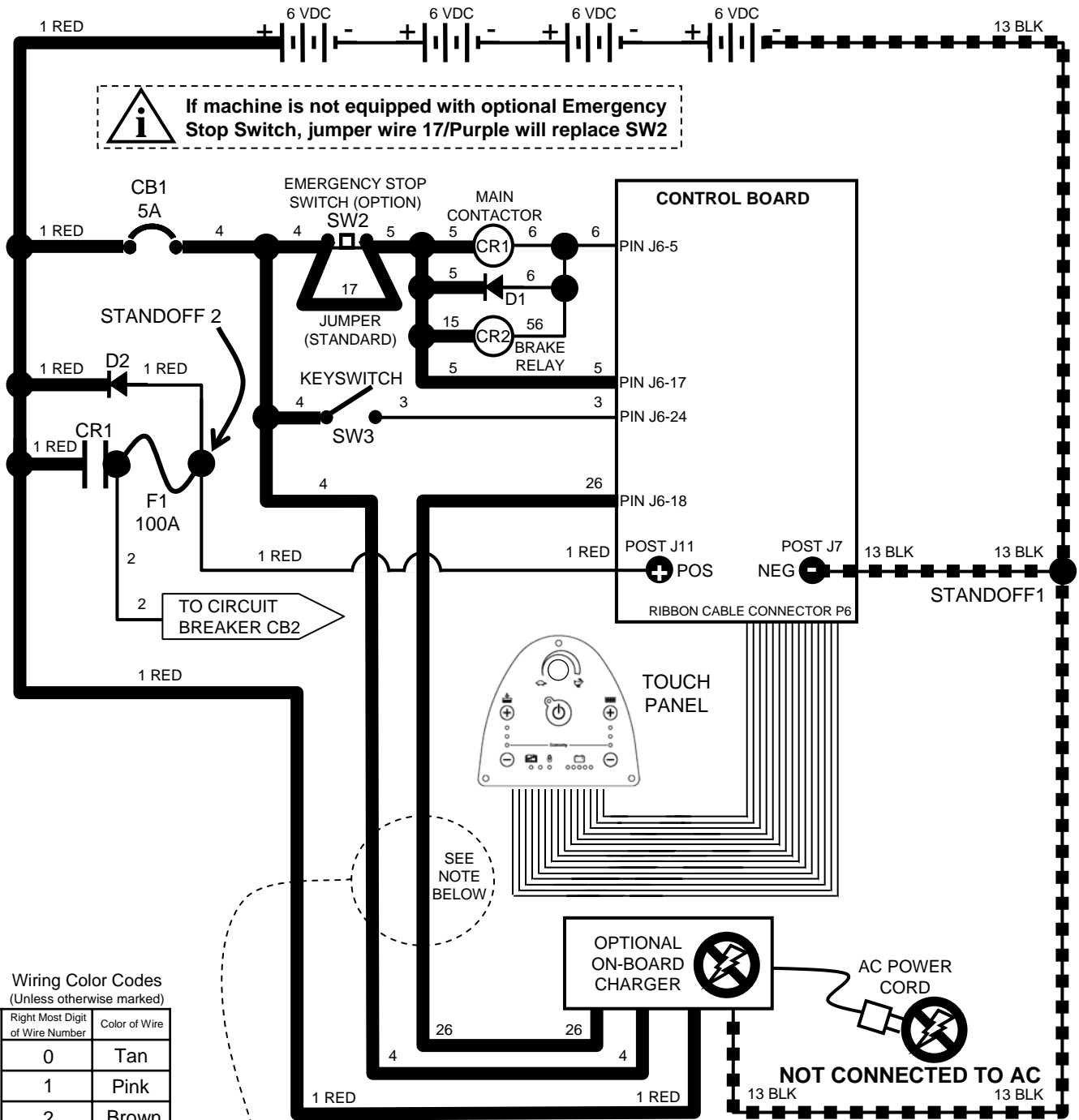

! If machine is not equipped with optional Emergency Stop Switch, jumper wire 17/Purple will replace SW2

! Be cautious when working near Control Board - Battery voltage is always present, even with Key OFF

! The battery charger uses a normally closed relay to send a signal to the control board – the relay opens when the charger is plugged in to AC power

! If On-Board Charger is connected to AC power, ALL machine functions will be disabled when Key Switch is turned ON

Wiring Color Codes (Unless otherwise marked)

Right Most Digit of Wire Number	Color of Wire
0	Tan
1	Pink
2	Brown
3	Orange
4	Yellow
5	Green
6	Blue
7	Purple
8	Gray
9	White

= Battery Negative or Logic Ground
 = Battery Positive or Logic High



T5 - Key OFF Power Distribution (With Optional On-Board Battery Charger)

CONDITIONS: Key OFF, On-Board battery charger **CONNECTED** to AC power

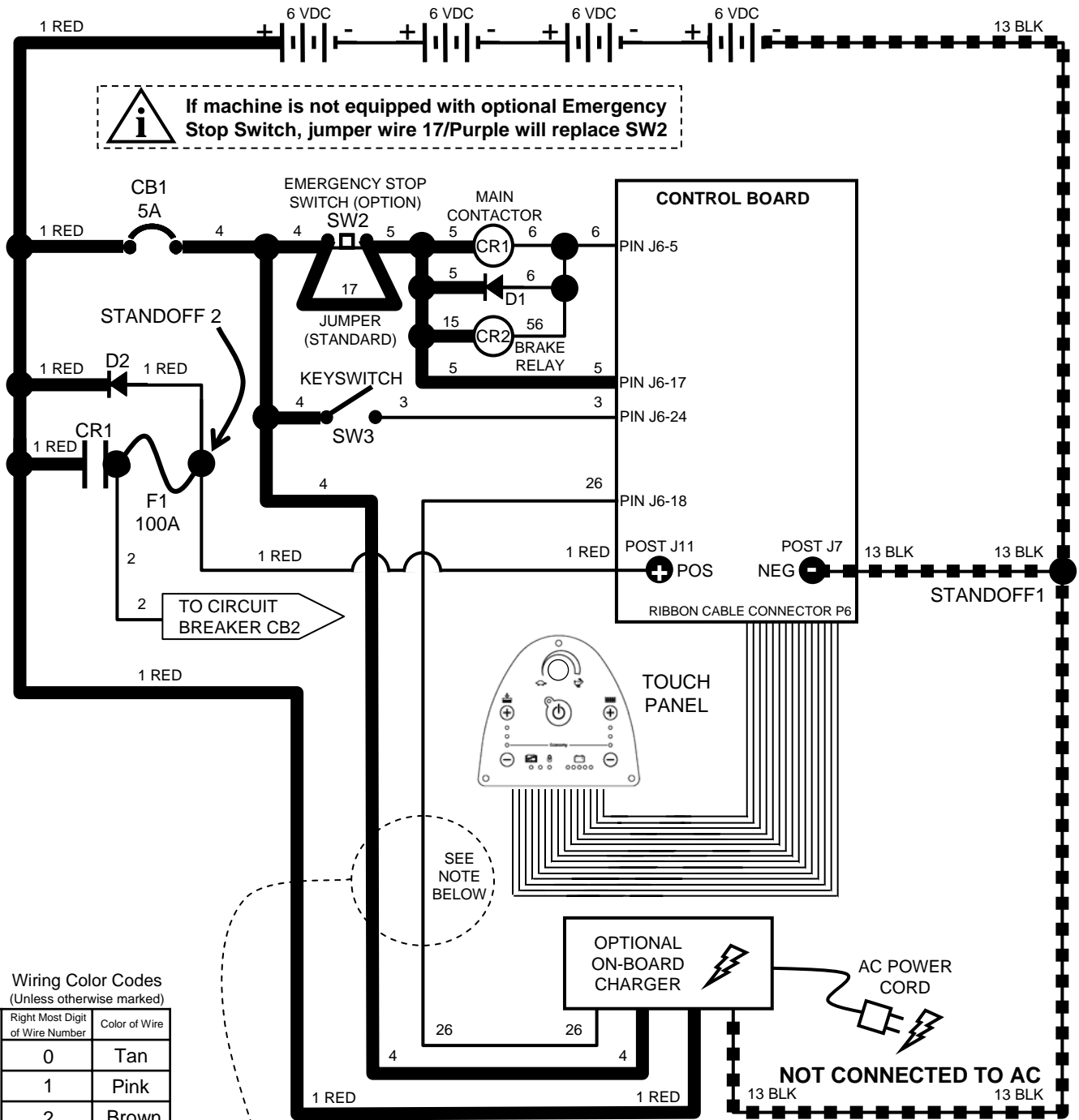

! If machine is not equipped with optional Emergency Stop Switch, jumper wire 17/Purple will replace SW2

! Be cautious when working near Control Board - Battery voltage is always present, even with Key OFF

! The battery charger uses a normally closed relay to send a signal to the control board – the relay opens when the charger is plugged in to AC power

! If On-Board Charger is connected to AC power, ALL machine functions will be disabled when Key Switch is turned ON

Wiring Color Codes (Unless otherwise marked)

Right Most Digit of Wire Number	Color of Wire
0	Tan
1	Pink
2	Brown
3	Orange
4	Yellow
5	Green
6	Blue
7	Purple
8	Gray
9	White

= Battery Negative or Logic Ground
 = Battery Positive or Logic High

E

T5 – Key OFF Propel System

CONDITIONS: Key OFF

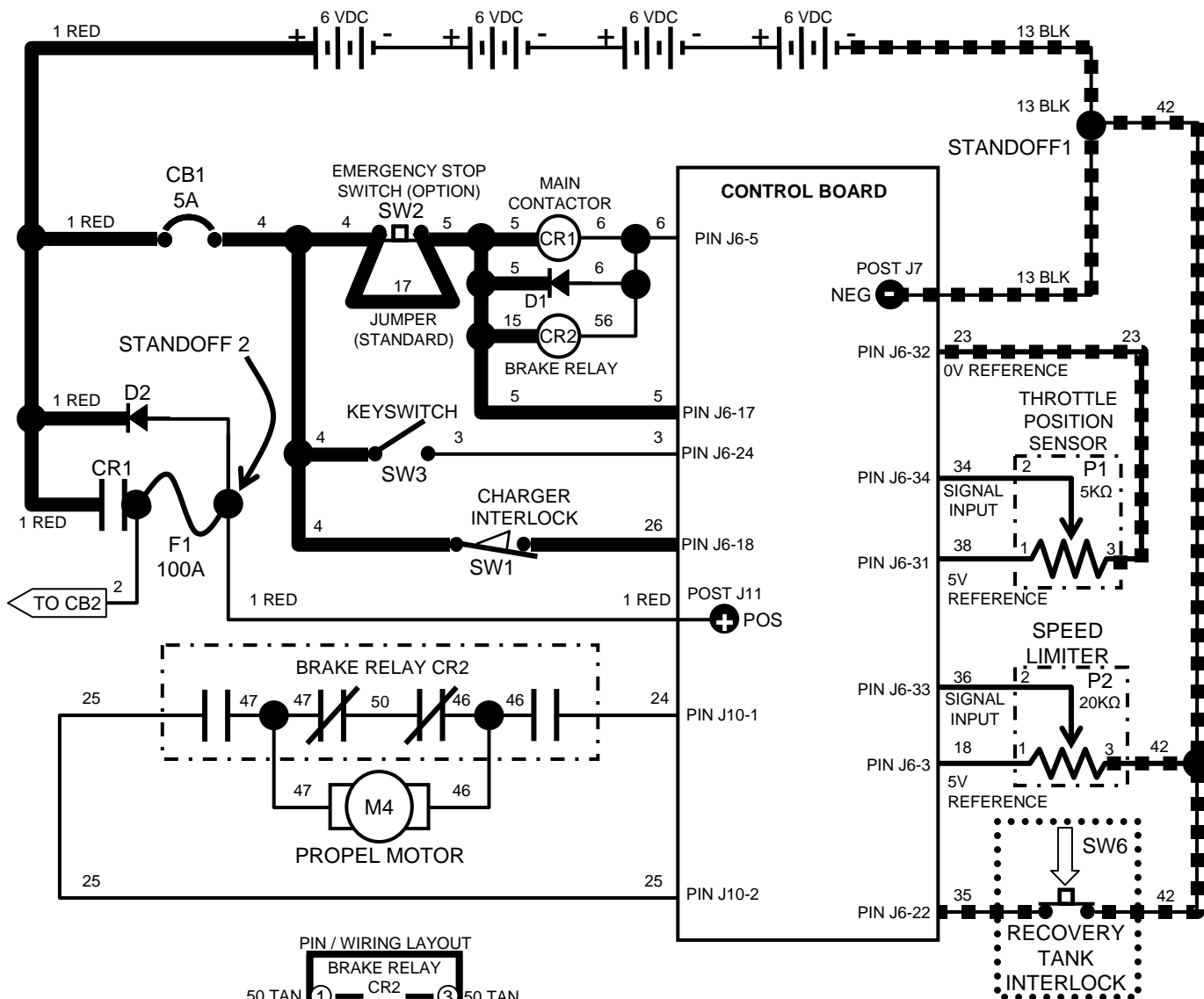

PIN / WIRING LAYOUT

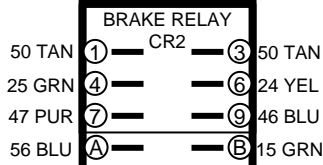

Wiring Color Codes (Unless otherwise marked)

Right Most Digit of Wire Number	Color of Wire
0	Tan
1	Pink
2	Brown
3	Orange
4	Yellow
5	Green
6	Blue
7	Purple
8	Gray
9	White

- = Battery Negative or Logic Ground
- = Battery Positive or Logic High

The Brake Relay (CR2) is used to provide braking when the Key Switch (SW3) is turned OFF.

Be cautious when working near Control Board - *Battery voltage is always present, even with Key OFF*

The Recovery Tank Interlock will prevent propelling of the machine when the Recovery Tank is raised; If the Recovery Tank Interlock switch is OPEN (tank raised), Fault LED # 1 will flash.

T5 - Key ON Power Distribution

CONDITIONS: Key ON, all machine functions OFF

The troubleshooting information from this page forward applies to machines with On-Board or Off-Board Chargers unless otherwise noted

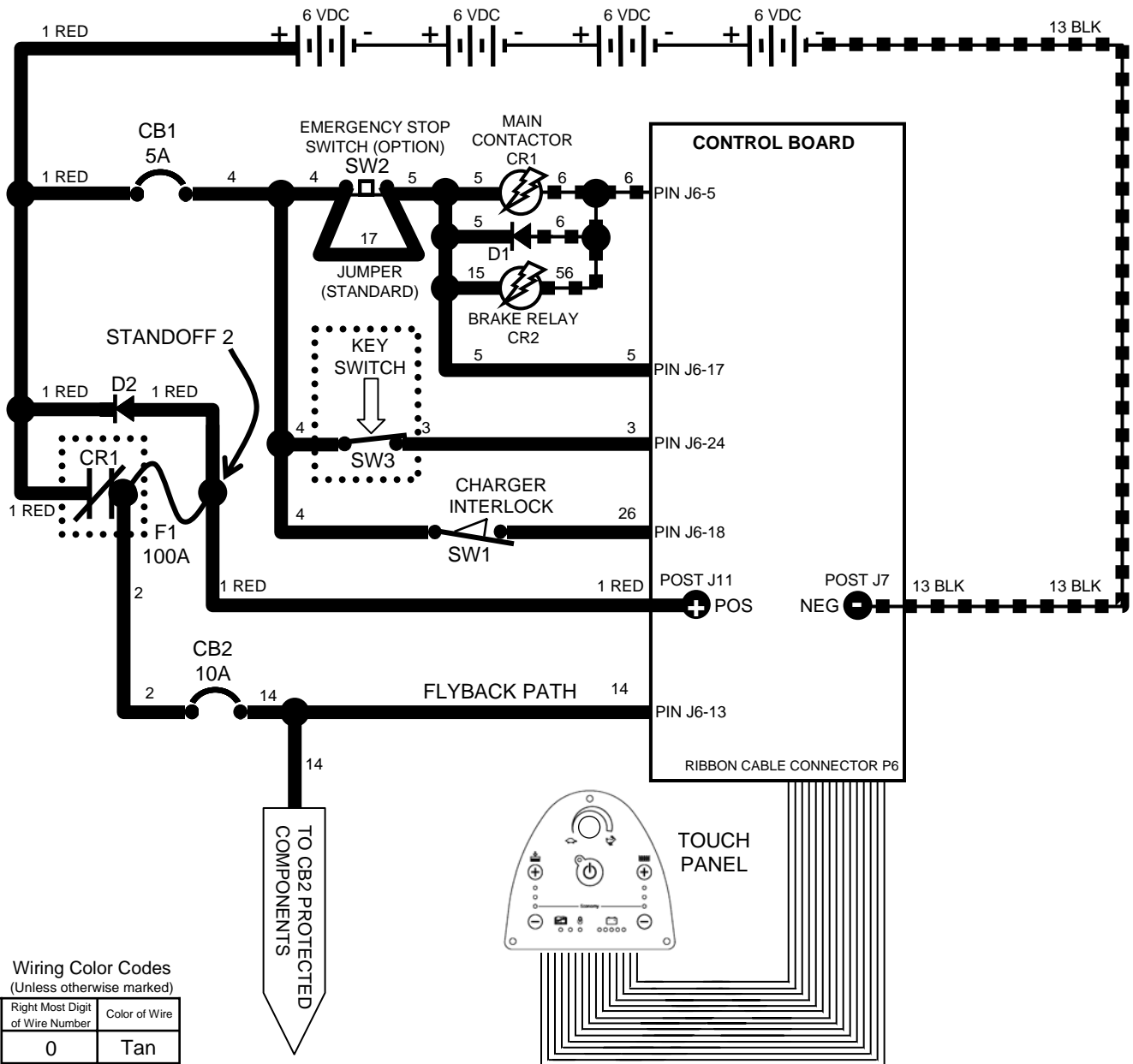

Wiring Color Codes
(Unless otherwise marked)

Right Most Digit of Wire Number	Color of Wire
0	Tan
1	Pink
2	Brown
3	Orange
4	Yellow
5	Green
6	Blue
7	Purple
8	Gray
9	White

= Battery Negative or Logic Ground
 = Battery Positive or Logic High

TO CB2 PROTECTED COMPONENTS

Be cautious when working near Control Board - Battery voltage is always present, even with Key OFF

If Charger Plug is connected to battery charger, ALL machine functions will be disabled when Key Switch is turned ON

The Flyback Path prevents high voltage spikes when a component is turned OFF

If machine is not equipped with optional Emergency Stop Switch, jumper wire 17/Purple will replace SW2

T5 – Propel Forward System

CONDITIONS: Key ON, forward propel engaged, all other machine functions OFF

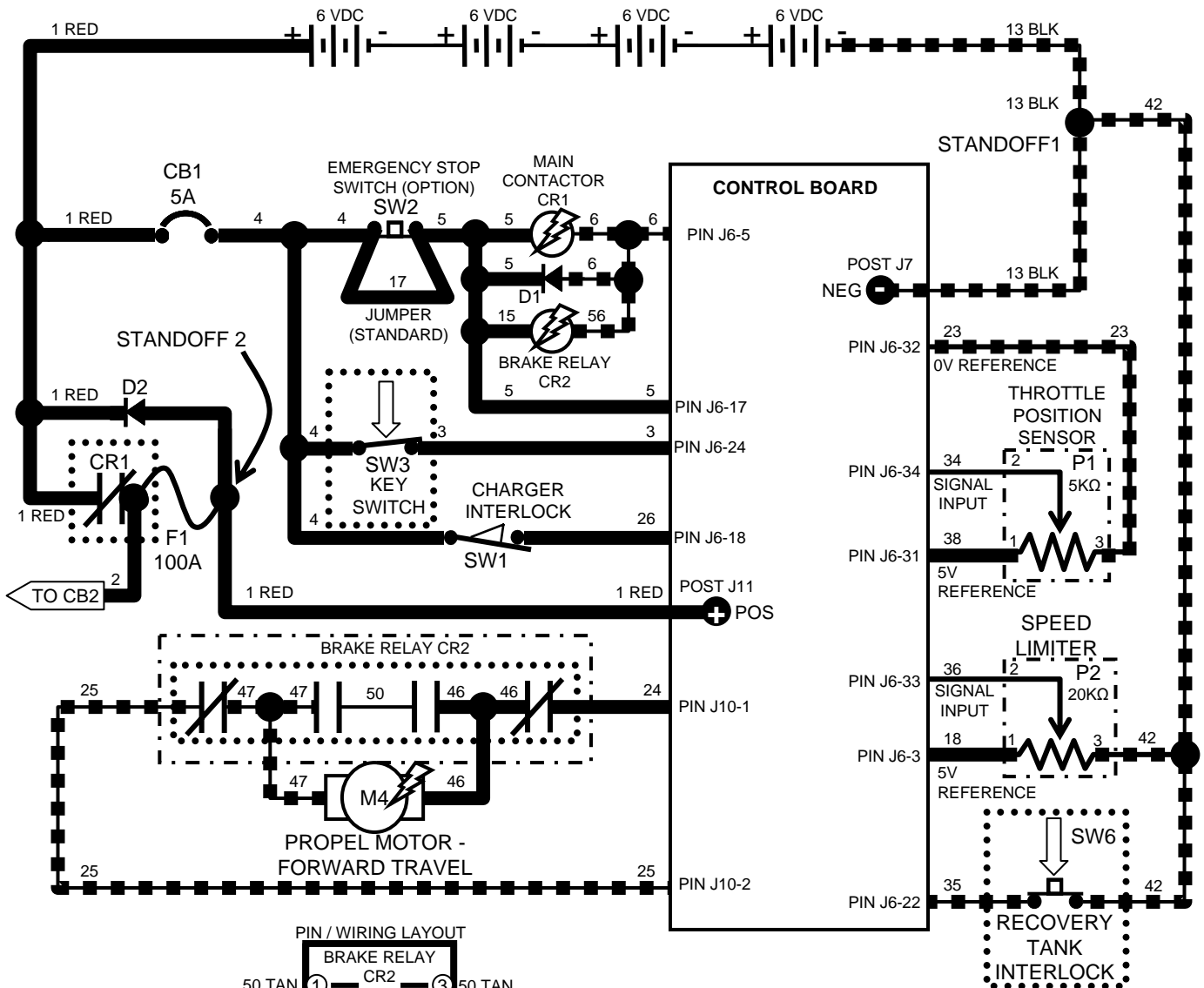

PIN / WIRING LAYOUT

BRAKE RELAY	
50 TAN	① — CR2 — ③ 50 TAN
25 GRN	④ — — ⑥ 24 YEL
47 PUR	⑦ — — ⑨ 46 BLU
56 BLU	⑩ — — ⑪ 15 GRN

Wiring Color Codes
(Unless otherwise marked)

Right Most Digit of Wire Number	Color of Wire
0	Tan
1	Pink
2	Brown
3	Orange
4	Yellow
5	Green
6	Blue
7	Purple
8	Gray
9	White

= Battery Negative or Logic Ground
 = Battery Positive or Logic High

The Brake Relay (CR2) is used to provide braking when the Key Switch (SW3) is turned OFF.

Be cautious when working near Control Board - *Battery voltage is always present, even with Key OFF*

The Throttle Position Sensor input signal will vary from 0v to 5v – voltages between 2.4v and 2.6v indicate neutral (machine stationary)

The Propel Motor (M4) is controlled by PWM; A higher duty cycle will result in higher travel speed

The Recovery Tank Interlock will prevent propelling of the machine when the Recovery Tank is raised; If the Recovery Tank Interlock switch is OPEN (tank raised), Fault LED # 1 will flash.



T5 – Propel Reverse System

CONDITIONS: Key ON, reverse propel engaged, all other machine functions OFF

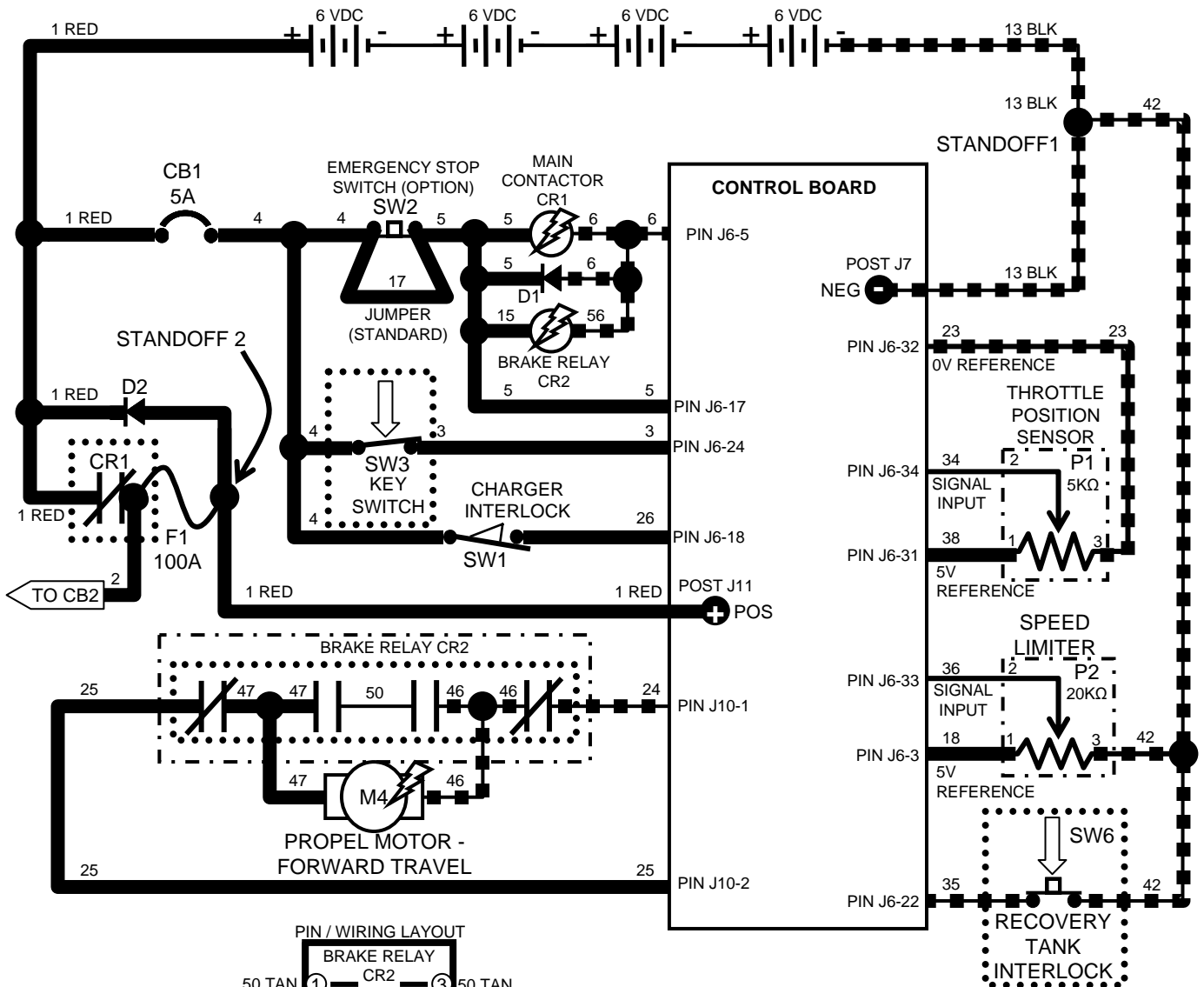

PIN / WIRING LAYOUT

BRAKE RELAY	
50 TAN	① — CR2 — ③ 50 TAN
25 GRN	④ — — ⑥ 24 YEL
47 PUR	⑦ — — ⑨ 46 BLU
56 BLU	⑩ — — ⑪ 15 GRN

Wiring Color Codes
(Unless otherwise marked)

Right Most Digit of Wire Number	Color of Wire
0	Tan
1	Pink
2	Brown
3	Orange
4	Yellow
5	Green
6	Blue
7	Purple
8	Gray
9	White

= Battery Negative or Logic Ground
 = Battery Positive or Logic High

The Brake Relay (CR2) is used to provide braking when the Key Switch (SW3) is turned OFF.

Be cautious when working near Control Board - *Battery voltage is always present, even with Key OFF*

The Throttle Position Sensor input signal will vary from 0v to 5v – voltages between 2.4v and 2.6v indicate neutral (machine stationary)

The Propel Motor (M4) is controlled by PWM; A higher duty cycle will result in higher travel speed

The Recovery Tank Interlock will prevent propelling of the machine when the Recovery Tank is raised; If the Recovery Tank Interlock switch is OPEN (tank raised), Fault LED # 1 will flash.

T5 – Propel System Neutral (no travel)

CONDITIONS: Key ON, propel NOT engaged, all other machine functions OFF

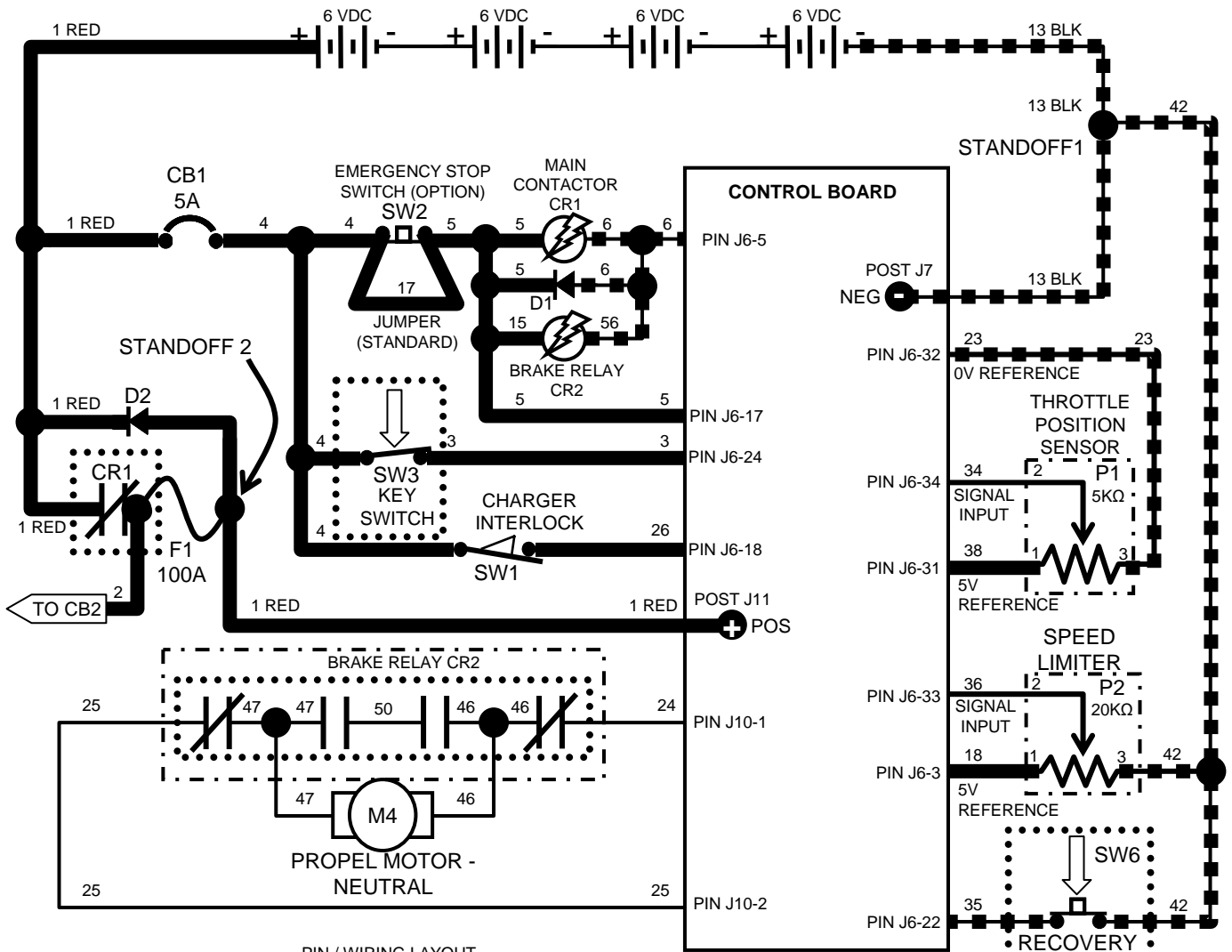

PIN / WIRING LAYOUT

BRAKE RELAY	
50 TAN	① — CR2 — ③ 50 TAN
25 GRN	④ — — ⑥ 24 YEL
47 PUR	⑦ — — ⑨ 46 BLU
56 BLU	⑩ — — ⑪ 15 GRN

Wiring Color Codes
(Unless otherwise marked)

Right Most Digit of Wire Number	Color of Wire
0	Tan
1	Pink
2	Brown
3	Orange
4	Yellow
5	Green
6	Blue
7	Purple
8	Gray
9	White

= Battery Negative or Logic Ground
 = Battery Positive or Logic High

The Brake Relay (CR2) is used to provide braking when the Key Switch (SW3) is turned OFF.

Be cautious when working near Control Board - Battery voltage is always present, even with Key OFF

The Throttle Position Sensor input signal will vary from 0v to 5v – voltages between 2.4v and 2.6v indicate neutral (machine stationary)

The Propel Motor (M4) is controlled by PWM; A higher duty cycle will result in higher travel speed

The Recovery Tank Interlock will prevent propelling of the machine when the Recovery Tank is raised; If the Recovery Tank Interlock switch is OPEN (tank raised), Fault LED # 1 will flash.

T5 – Scrub Brushes

CONDITIONS: Key ON, propel engaged, One Step switch activated

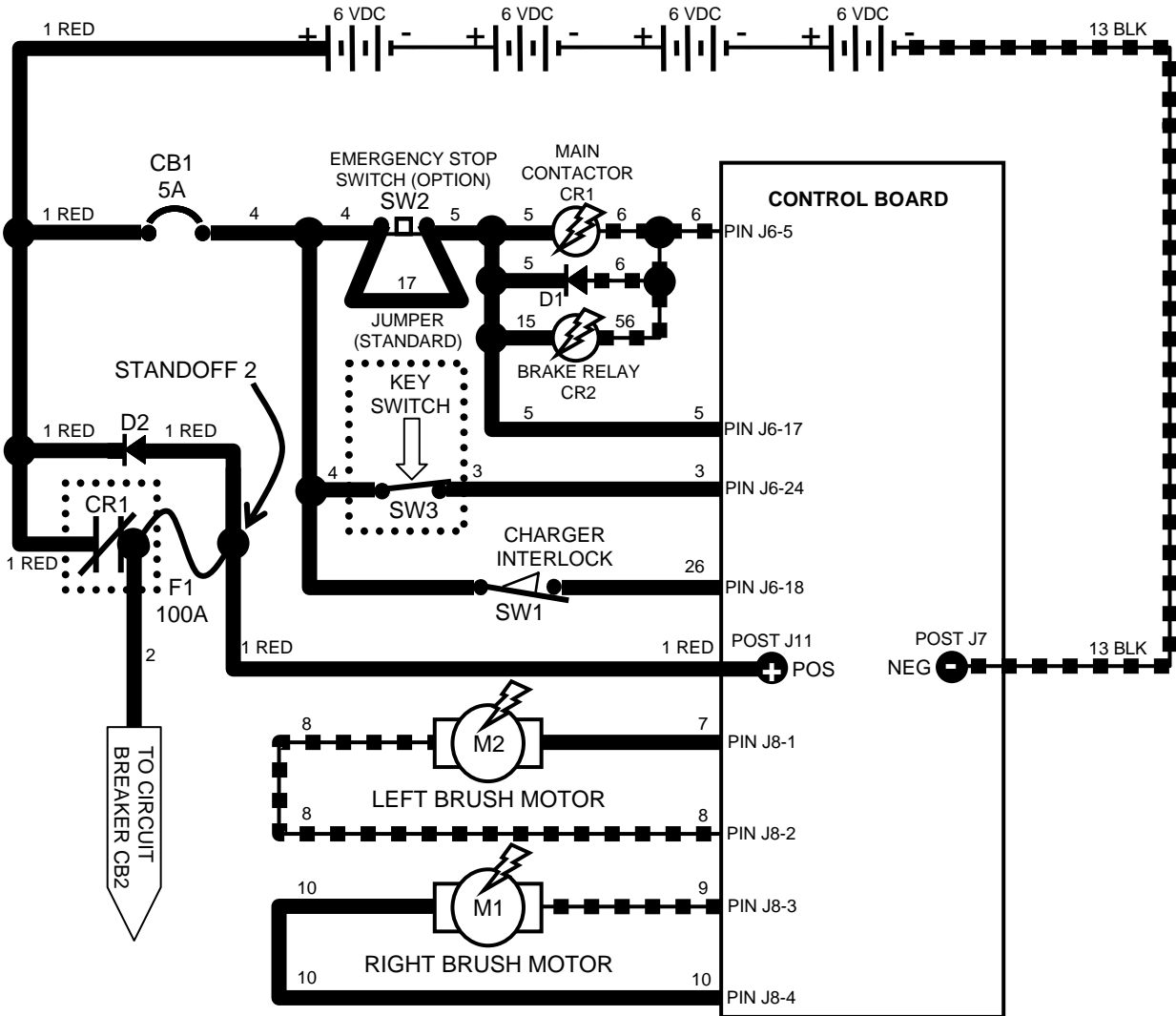

Wiring Color Codes
(Unless otherwise marked)

Right Most Digit of Wire Number	Color of Wire
0	Tan
1	Pink
2	Brown
3	Orange
4	Yellow
5	Green
6	Blue
7	Purple
8	Gray
9	White



**Be cautious when working near Control Board -
Battery voltage is always present, even with Key OFF**



**The Brush Motors (M1 & M2) are speed controlled
by PWM; As the batteries are discharged, the
Control Board will reduce the motor speed**

- = Battery Negative or Logic Ground
- = Battery Positive or Logic High

T5 – Vacuum Fan System

CONDITIONS: Key ON, squeegee lowered

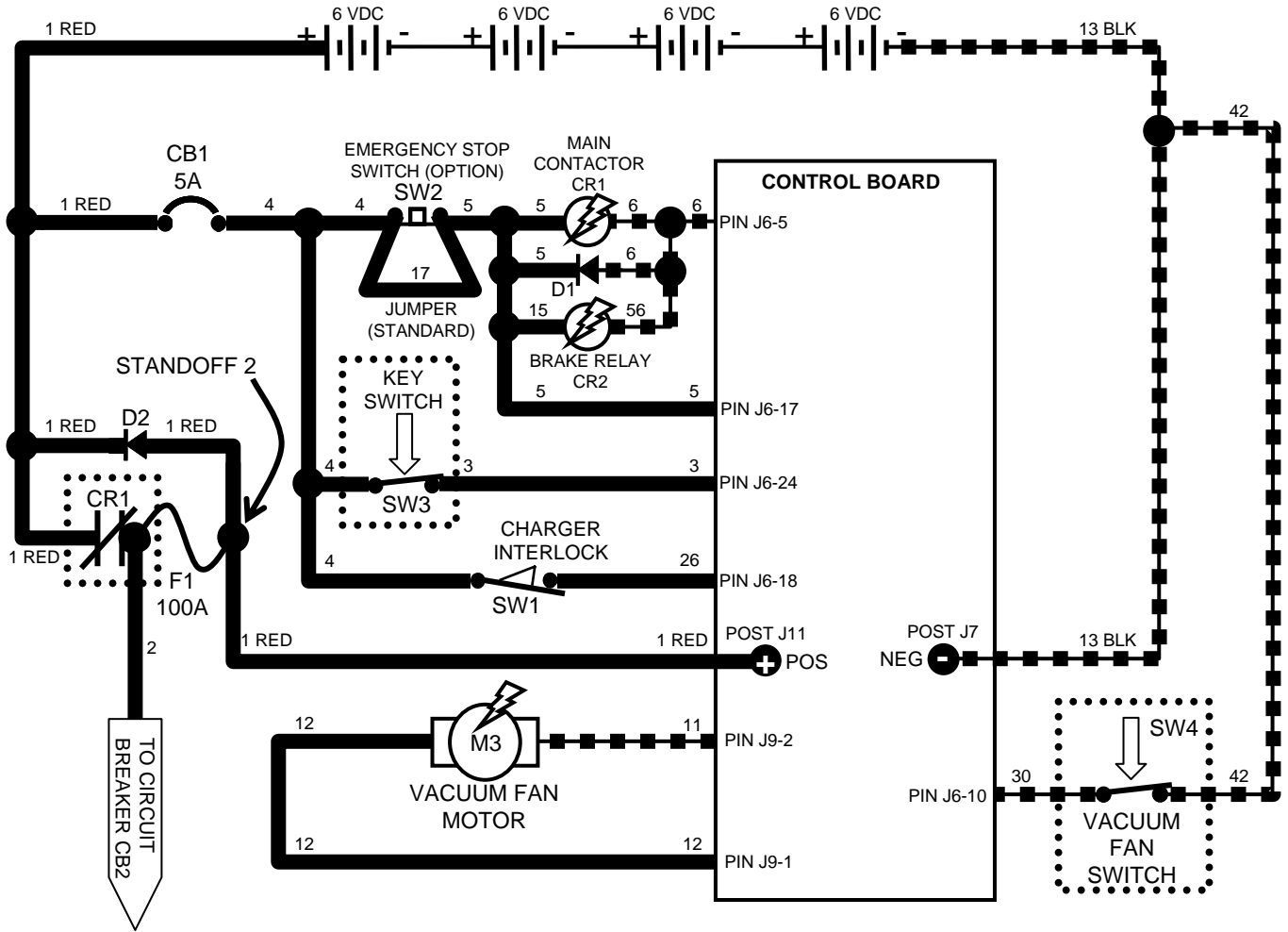

Be cautious when working near Control Board - Battery voltage is always present, even with Key OFF

The Vacuum Fan Motor (M3) is controlled by PWM; The "Economy" setting will reduce the duty cycle to conserve battery energy and reduce noise when the scrub system is activated

**Vacuum Fan Voltages:
Economy Mode – 21 volts
Standard Mode – battery voltage**

Wiring Color Codes (Unless otherwise marked)

Right Most Digit of Wire Number	Color of Wire
0	Tan
1	Pink
2	Brown
3	Orange
4	Yellow
5	Green
6	Blue
7	Purple
8	Gray
9	White

= Battery Negative or Logic Ground
 = Battery Positive or Logic High

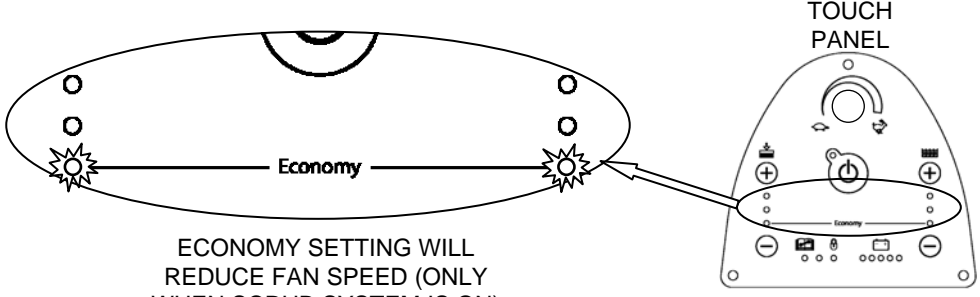

ECONOMY SETTING WILL REDUCE FAN SPEED (ONLY WHEN SCRUB SYSTEM IS ON)

T5 – Conventional Solution Solenoid Valve

CONDITIONS: Key ON, propel engaged, One Step switch activated, FaST switch OFF

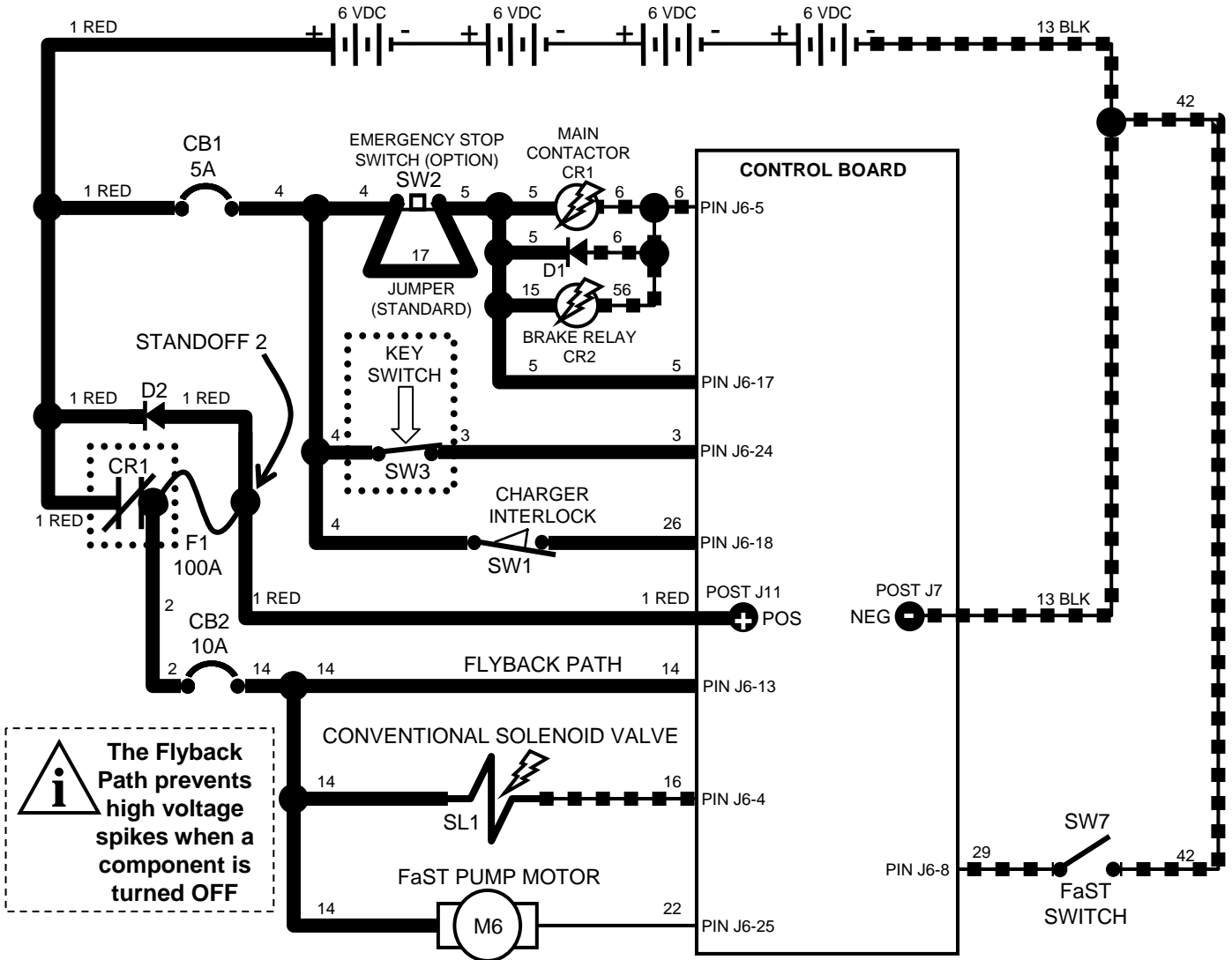

The Flyback Path prevents high voltage spikes when a component is turned OFF

Be cautious when working near Control Board - Battery voltage is always present, even with Key OFF

The Conventional Solenoid Valve (SL1) is controlled by PWM; As more Solution LED's are lit, the duty cycle is increased, and more solution is applied to the floor.

Wiring Color Codes (Unless otherwise marked)

Right Most Digit of Wire Number	Color of Wire
0	Tan
1	Pink
2	Brown
3	Orange
4	Yellow
5	Green
6	Blue
7	Purple
8	Gray
9	White

--- = Battery Negative or Logic Ground
 — = Battery Positive or Logic High

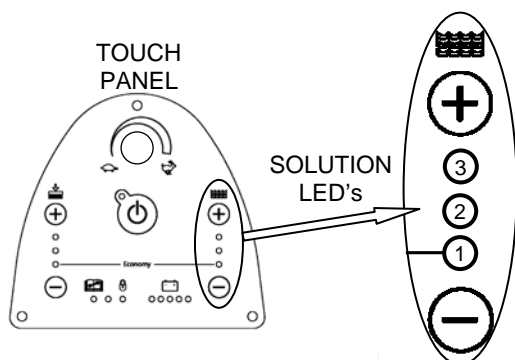

CONVENTIONAL MODE



T5 – FaST Water Pump

CONDITIONS: Key ON, propel engaged, One Step switch activated, FaST switch ON

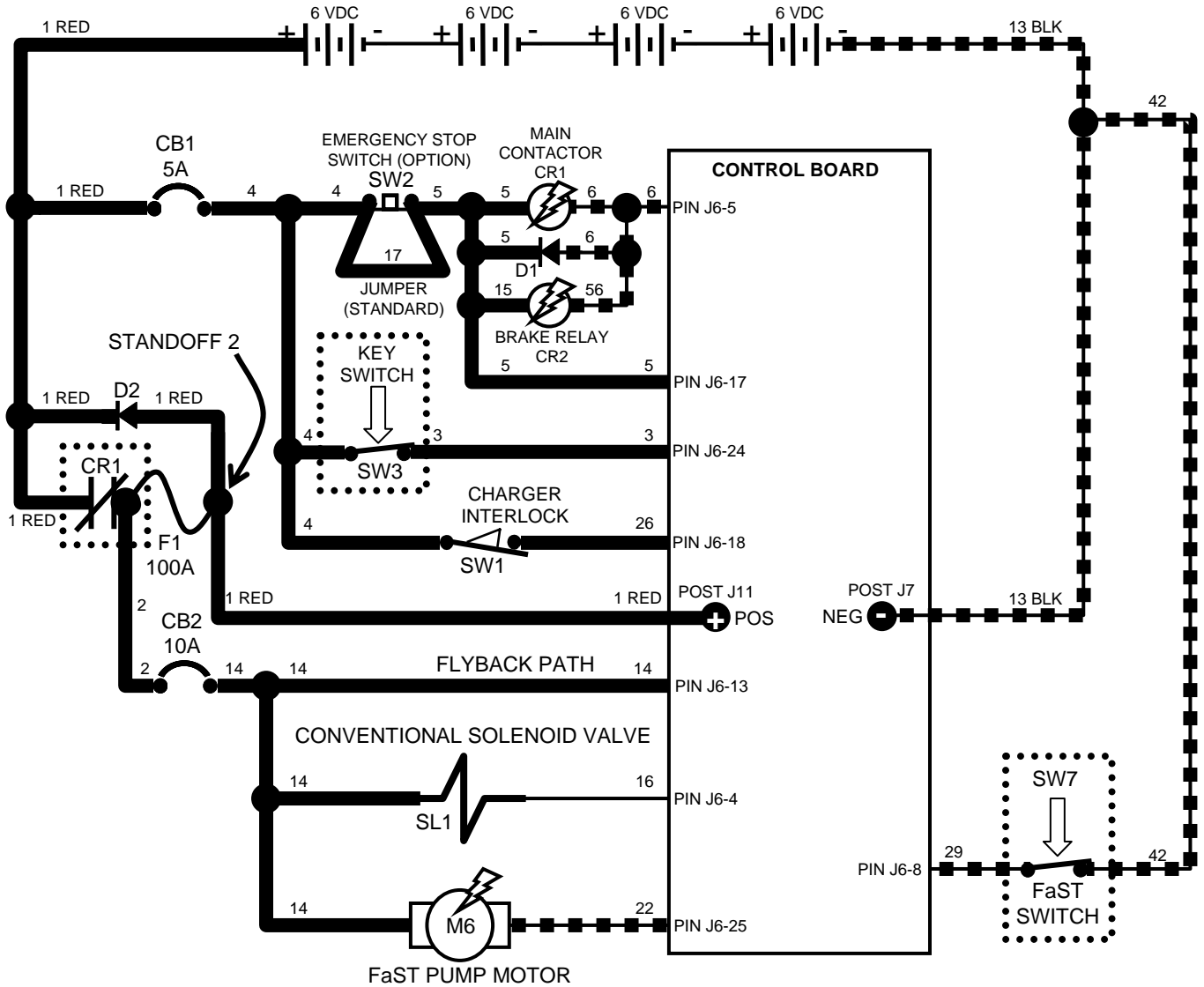

Wiring Color Codes
(Unless otherwise marked)

Right Most Digit of Wire Number	Color of Wire
0	Tan
1	Pink
2	Brown
3	Orange
4	Yellow
5	Green
6	Blue
7	Purple
8	Gray
9	White

- = Battery Negative or Logic Ground
- = Battery Positive or Logic High

Be cautious when working near Control Board - Battery voltage is always present, even with Key OFF

The Flyback Path prevents high voltage spikes when a component is turned OFF



T5 – Hour Meter & Off-Aisle Wand Water Pump

CONDITIONS FOR HOUR METER OPERATION: Key ON, propel engaged AND/OR vacuum fan ON

CONDITIONS FOR OFF-AISLE WAND WATER PUMP: Key ON, wand switch ON

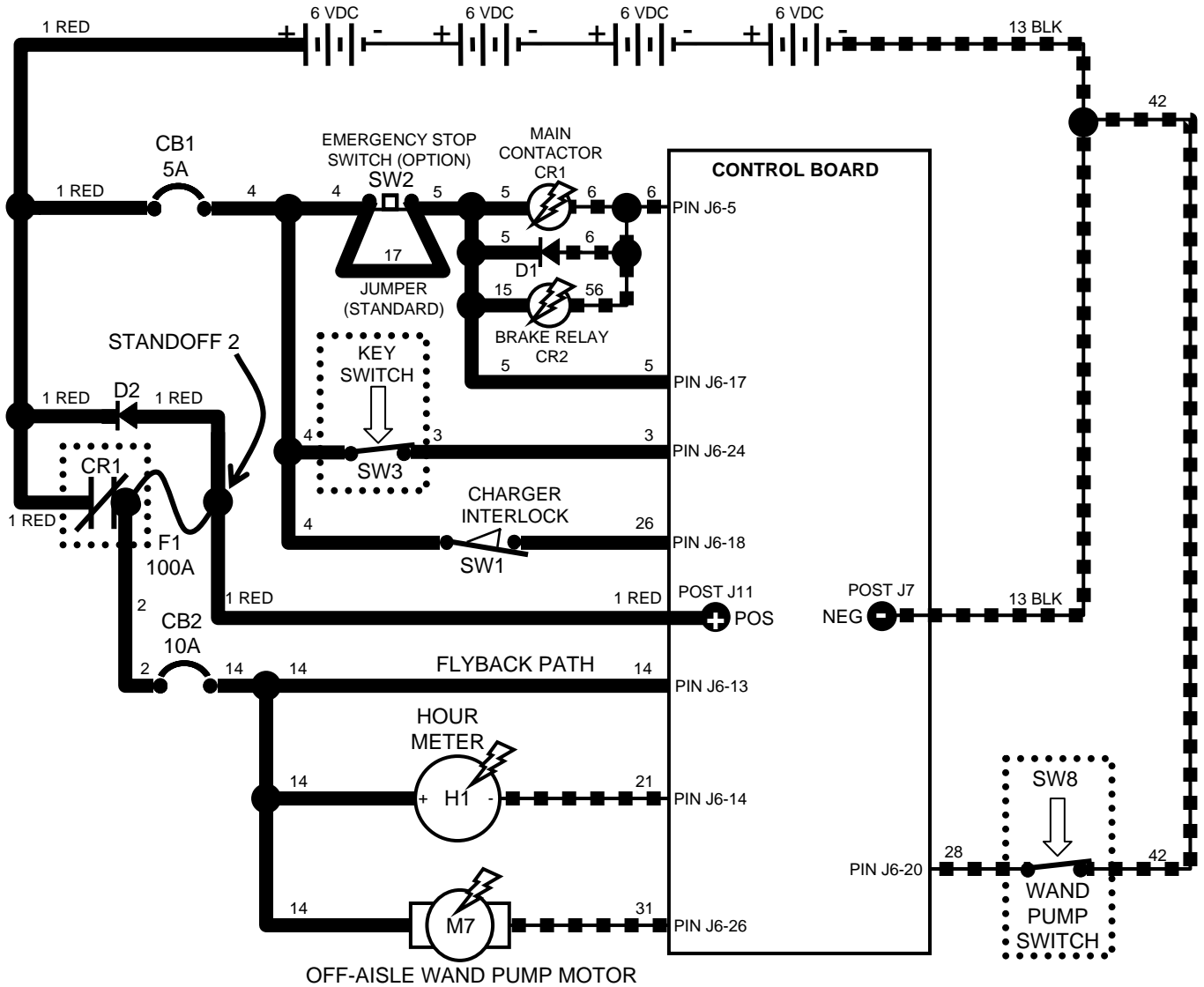

Wiring Color Codes
(Unless otherwise marked)

Right Most Digit of Wire Number	Color of Wire
0	Tan
1	Pink
2	Brown
3	Orange
4	Yellow
5	Green
6	Blue
7	Purple
8	Gray
9	White

- = Battery Negative or Logic Ground
- = Battery Positive or Logic High

! Be cautious when working near Control Board - *Battery voltage is always present, even with Key OFF*

i The Flyback Path prevents high voltage spikes when a component is turned OFF

OFF-AISLE WAND MODE

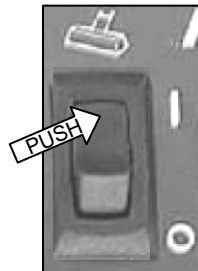

T5 – Scrub Head Actuator LOWER (Extend)

CONDITIONS: Key ON, One Step switch activated

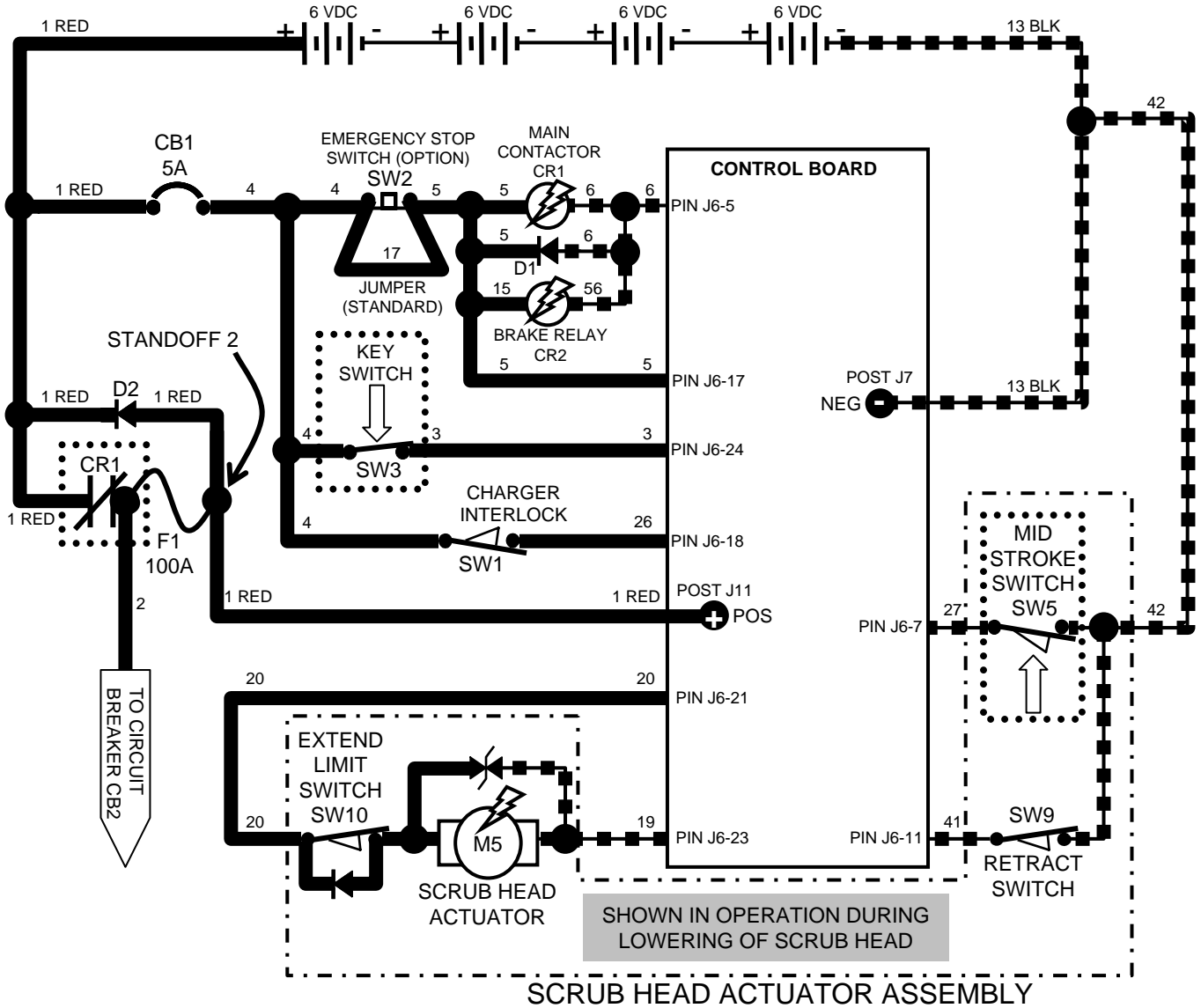

Wiring Color Codes
(Unless otherwise marked)

Right Most Digit of Wire Number	Color of Wire
0	Tan
1	Pink
2	Brown
3	Orange
4	Yellow
5	Green
6	Blue
7	Purple
8	Gray
9	White

= Battery Negative or Logic Ground
 = Battery Positive or Logic High

Be cautious when working near Control Board - Battery voltage is always present, even with Key OFF

The Extend Limit Switch SW10 is an additional safety device to prevent over-extension of the actuator; The actual length of extension is based upon the current draw of the scrub brush motors

Scrub Head Actuator Switches Logic Chart

condition \ switch	SW5	SW9	SW10
Fully Retracted (UP)	OPEN	OPEN	CLOSED
Fully Extended (DOWN)	CLOSED	CLOSED	OPEN
Retracting (RAISING)	*	CLOSED	CLOSED
Extending (LOWERING)	*	CLOSED	CLOSED

* SW5 closes when actuator is extended 2" (50mm) or more

T5 – Scrub Head Actuator RAISE (Retract)

CONDITIONS: Key ON, One Step switch deactivated

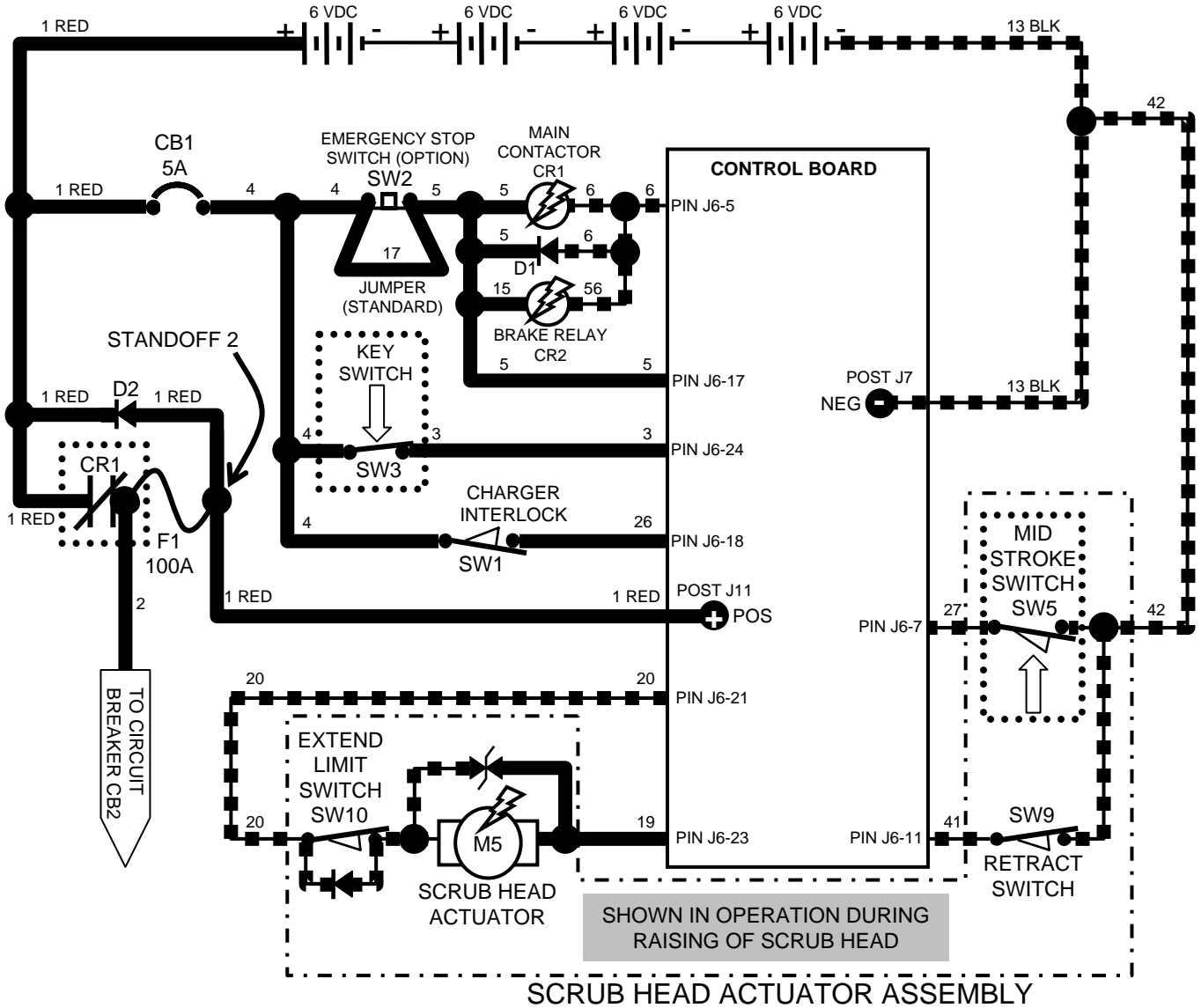

Wiring Color Codes
(Unless otherwise marked)

Right Most Digit of Wire Number	Color of Wire
0	Tan
1	Pink
2	Brown
3	Orange
4	Yellow
5	Green
6	Blue
7	Purple
8	Gray
9	White

= Battery Negative or Logic Ground
 = Battery Positive or Logic High

Be cautious when working near Control Board - Battery voltage is always present, even with Key OFF

The Extend Limit Switch SW10 is an additional safety device to prevent over-extension of the actuator; The actual length of extension is based upon the current draw of the scrub brush motors

Scrub Head Actuator Switches Logic Chart

condition \ switch	SW5	SW9	SW10
Fully Retracted (UP)	OPEN	OPEN	CLOSED
Fully Extended (DOWN)	CLOSED	CLOSED	OPEN
Retracting (RAISING)	*	CLOSED	CLOSED
Extending (LOWERING)	*	CLOSED	CLOSED

* SW5 closes when actuator is extended 2" (50mm) or more

T5 – Operational Modes & Interlocks

Mode	Entry Sequence	Indicator	Function
Forward	-Bail Engaged in Forward Direction	-Decal and Position of Bail	Forward movement of machine
Reverse	-Bail Engaged in Reverse Direction	-Decal and Position of Bail	Reverse movement of machine
Scrub Mode	-Press One-Step Scrub Button ON -Lower Squeegee to Floor	-One Step Scrub LED ON -Vacuum Fan Running	Activate Scrub Brushes, Vacuum Fan & Solution Flow operations; Maximum propel speed is limited to 220 ft/min
FaST Mode	-Press One Step Scrub Button ON -Press FaST Switch ON	-One Step Scrub LED ON -FaST Switch ON & Solution Flow LED's OFF	Activate FaST foam solution flow when scrub and propel are engaged
Conventional Solution Mode	-Press One Step Scrub Button ON -Press FaST Switch OFF	-One Step Scrub LED ON -FaST Switch OFF & Solution Flow LED(s) ON	Activate Conventional solution flow when scrub and propel are engaged
Double Scrub (no water pickup)	-Press One Step Scrub Button ON -Raise Squeegee	-One Step Scrub LED ON -Vacuum Fan OFF	Activate Scrub Brushes, apply cleaning solution with no water pickup
Water pickup (no Scrub)	-Lower Squeegee to Floor	-One Step Scrub LED OFF -Vacuum Fan ON	Collect solution on floor with squeegee without scrubbing floor
Economy Mode	-Press Brush Pressure Decrease (-) to one LED -Press Solution Flow Decrease (-) to one LED	-Lower Brush Pressure (#1) LED ON; Middle (#2) & Upper (#3) LED's OFF -Lower Solution Flow (#1) LED ON; Middle (#2) & Upper (#3) LED's OFF	Reduce Scrub Brush and Fan speeds (to prolong battery life, reduce noise, lower water usage)
Economy Mode w/ FaST	-Press Brush Pressure Decrease (-) to one LED -Press FaST Switch ON	-Lower Brush Pressure (#1) LED ON; Middle (#2) & Upper (#3) LED's OFF -FaST Switch ON & Solution Flow LED's OFF	Reduce Scrub Brush and Fan speeds (to prolong battery life, reduce noise, lower water usage)
Battery Discharged	-Battery voltage at or below full discharge voltage	-Red (#1) LED (on Battery Gauge) flashing	Disable Scrub and Vacuum functions (Additional operating time available by re-engaging scrub system or squeegee)
Propel Interlock or Motor Over Current Fault	-Controller sensed a propel interlock fault or an Over Current condition in a motor	-Various LED's "rippling" or flashing	Prevent movement of machine or prevent damage to motors; Refer to appropriate chart for more information



T5 – Diagnostic & Fault Alarms

Diagnostic LED Codes

Fault	Entry Sequence	Indicator	Function	Possible Solutions
High Throttle Disable	Key switch turned ON with propel engaged	Battery Gauge LED's continuously "ripple" UP and Down	Prevents movement of machine if propel is engaged before key is switched ON	Release propel bail before turning Key Switch ON; Adjust Throttle Position Sensor neutral voltage (2.4v to 2.6v)
Charger Connected	Battery charger connected to machine and/or AC power with Key Switch ON	Fault LED's continuously "ripple" UP and DOWN	Prevents operation of the machine with charger plugged in	Plug in Battery Charger only when machine is not in use
Throttle	Controller sensed an out-of-range Throttle signal	Fault LED's #1 and #2 flashing	Prevents movement of machine with invalid throttle voltage. Scrub function shuts off.	Repair throttle wiring; Repair or replace machine Control Board
Recovery Tank	Controller sensed an open circuit - Recovery Tank is raised	Fault LED #1 flashing	Prevents movement of the machine when Recovery Tank is raised	Lower Recovery Tank when operating machine
Emergency Stop Switch	Controller sensed an open circuit - Emergency Stop Switch activated	All Battery Gauge LED's flashing	Turns OFF all machine functions	Reset Emergency Stop Switch
Scrub Head Actuator Motor	Scrub Head Actuator motor stalled or actuator position unknown	Fault LED's #1 and #3 flashing	Notify operator of actuator fault	Examine Scrub Head Actuator or linkage for binding; Repair or replace Scrub Head Actuator
FaST Pump	FaST Pump circuit OPEN or SHORTED	Fault LED #3 flashing	Notify operator of FaST Pump fault	Repair FaST Pump wiring; Repair or replace FaST Pump
Wand Pump	Wand Pump circuit OPEN or SHORTED	Fault LED's #1, #2 and #3 flashing	Notify operator of Wand Pump fault	Repair Wand Pump wiring; Repair or replace Wand Pump
High Current	Controller sensed an Over Current condition in a motor	Various LED's flashing	Prevent damage to motors; Refer to appropriate chart for more information	Repair motor wiring; Repair or replace motor



High Current Faults

Fault	Description	Indicator	Function
Excessive Propel current	- more than 24A for 10 minutes - more than 35A for 1 minute - more than 45A for 30 seconds - more than 60A for 5 seconds	Fault LED's #2 and #3 flashing	Prevents movement of the machine; Turn Key Switch OFF/ON to propel for another time period.
Excessive Left Brush Motor current	Disk Heads - more than 30A for 1 minute - more than 35A for 2 seconds	Fault LED #1 and Lower Brush Pressure (#1) LED flashing	Turns OFF all Scrub functions
	Cylindrical Heads - more than 30A for 1 minute - more than 35A for 2 seconds		
Excessive Right Brush Motor current	Disk Heads - more than 30A for 1 minute - more than 35A for 2 seconds	Fault LED #3 and Lower Brush Pressure (#1) LED flashing	Turns OFF all Scrub functions
	Cylindrical Heads - more than 30A for 1 minute - more than 35A for 2 seconds		
Excessive Vacuum Fan Motor current	- more than 27A for 30 seconds - more than 30A for 5 seconds	Fault LED #2 flashing	Turns OFF all Scrub functions

T5 – Diagnostic & Configuration Modes

Mode	Entry Sequence	Indicator	Function
Display Software Revision Mode	Press and hold One Step Button, turn key switch ON, wait 10 seconds, release One Step Button	Upper Brush Pressure LED blinks Tens of days of month, Upper Solution Flow LED blinks Single day of month	Blinking Brush Pressure and Solution Flow LED's indicate revision date (Refer to Display Software Revision Mode page for more information)
		Middle Brush Pressure LED blinks Tens of month, Middle Solution Flow LED blinks Single month	
		Lower Brush Pressure LED blinks Tens of year, Lower Solution Flow LED blinks out Single year	
Self Test Mode	Press and hold Increase Solution Flow (+) and Decrease Brush Pressure (-) Buttons, turn key switch ON, wait 10 seconds, release buttons	<u>Start of test</u> - Both Scrub Brush motors run <u>End of test</u> - LED's indicate system pass or fail	Solid lit One Step LED indicates OK, A Flashing LED indicates an OPEN Fault, A Solid lit LED (other than One Step) indicates a SHORT Fault (Refer to Self Test Mode page for more information)
Input Display Mode	Press and hold Decrease Solution Flow (-) Button, turn key switch ON, release button after forth battery LED starts to blink	LED's will indicate the the state of the control board inputs	Shows state of control board inputs from various switches and sensors (Refer to Input Display Mode pages for more information)
Manual Mode	Press and hold Decrease Brush Pressure (-) Button, turn key switch ON, release after Lowest Brush Pressure LED starts to blink.	Lowest down pressure LED will blink	Allows operation of individual functions without the safety interlocks affecting or controlling them (Refer to Manual Mode pages for more information)
Propel Diagnostics Mode	Press and hold Decrease Solution Flow (-) and Increase Brush Pressure (+) Buttons, turn key switch ON, release after One Step LED starts to blink	Battery Gauge LED's indicate position of throttle	Provides information regarding throttle input signal and propel motor current (Refer to Propel Diagnostics Mode page for more information)
Battery Select Mode	Press and hold the Increase Solution Flow (+) Button, turn key switch ON, release after one Battery LED starts to blink	Any one of lower 4 Battery Gauge LED's blinks	Allows selection of battery type (Refer to Battery Select Mode page for more information)
Supervisor Mode	Press and hold Increase Solution Flow (+) and Increase Brush Pressure (+) Buttons, turn key switch ON, release after battery LED 1 or 3 starts to blink	Battery LED #3 (Green) flashing - Supervisor mode enabled	Toggle Supervisor Mode. When enabled, the scrub mode settings are disabled and Fault LED #3 is lit. If Solution Flow or Brush Pressure buttons are pressed, Fault LED #3 will blink. (Refer to Supervisor Mode page for more information)
		Battery LED #1 (Red) flashing - Supervisor mode disabled	
Scrub Propel Speed Selection Mode	Press and hold Increase Brush Pressure (+) Button, turn key switch ON, release after selecting desired Brush Pressure LED setting	Brush Pressure Lower, Middle, and Upper LED's represents LOW, MEDIUM and HIGH maximum Forward Scrubbing Propel Speed selection	Allows selection of maximum forward speed during scrubbing LOWER (#1) LED = 150 ft/min MIDDLE (#2) LED = 200 ft/min UPPER (#3) LED = maximum speed (Refer to Scrub Propel Speed Selection Mode page for more information)
Scrub Head Selection Mode	Press and hold Decrease Solution Flow (-) and Decrease Brush Pressure (-) Buttons, turn key switch ON, release after one Brush Pressure LED and one Solution Flow LED is lit. To change setting, press & hold One Step Button until it blinks, then press the Brush Pressure (+) Button or Solution Flow (+) Button to change setting.	<u>Lower Brush Pressure LED (#1) – Disk</u> -Lower Solution Flow LED (#1) – 24" -Middle Solution Flow LED (#2) – 28" -Upper Solution Flow LED (#3) – 32" <u>Middle Brush Pressure LED (#2) – Cylindrical</u> -Lower Solution Flow LED (#1) – 26" -Upper Solution Flow LED (#3) – 32"	Allows machine to be configured for various scrub heads (Refer to Scrub Head Selection Mode page for more information)





T5 – Display Software Revision Mode

(Page 1 of 2)

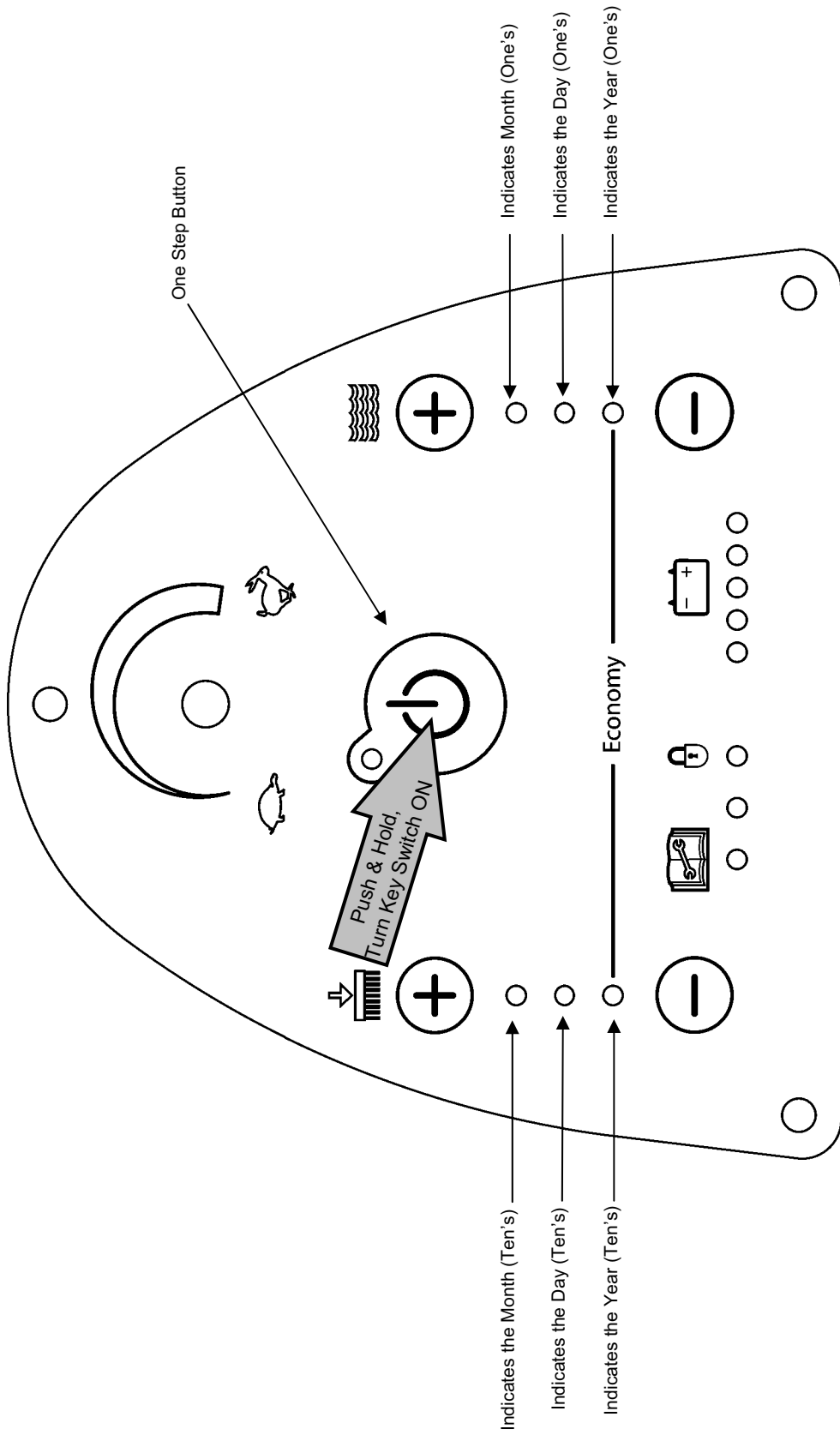

Holding the One Step button on Power-up puts you into the software revision display mode. The number of blinks by the Down Pressure and Water level LED's represents the software revision.

1. The Highest Pressure (ten's) & water level (one's) numbers blinking together represents the month.
 2. The Middle Pressure (ten's) & water level (one's) numbers blinking together represents the day.
 3. The Low Pressure (ten's) & water level (one's) numbers blinking together represents the year.
- No blinking of an LED means zero. For example if the high pressure LED does not blink and the high water LED blinks six times, that means the month is JUNE. Also if the Middle Pressure LED blinks twice and the Middle water blinks once, that means the day is the 21st.

Note: The software revision LED will continue to blink until the machine is turned off.

T5 – Display Software Revision Mode

(Page 2 of 2)

EXAMPLE

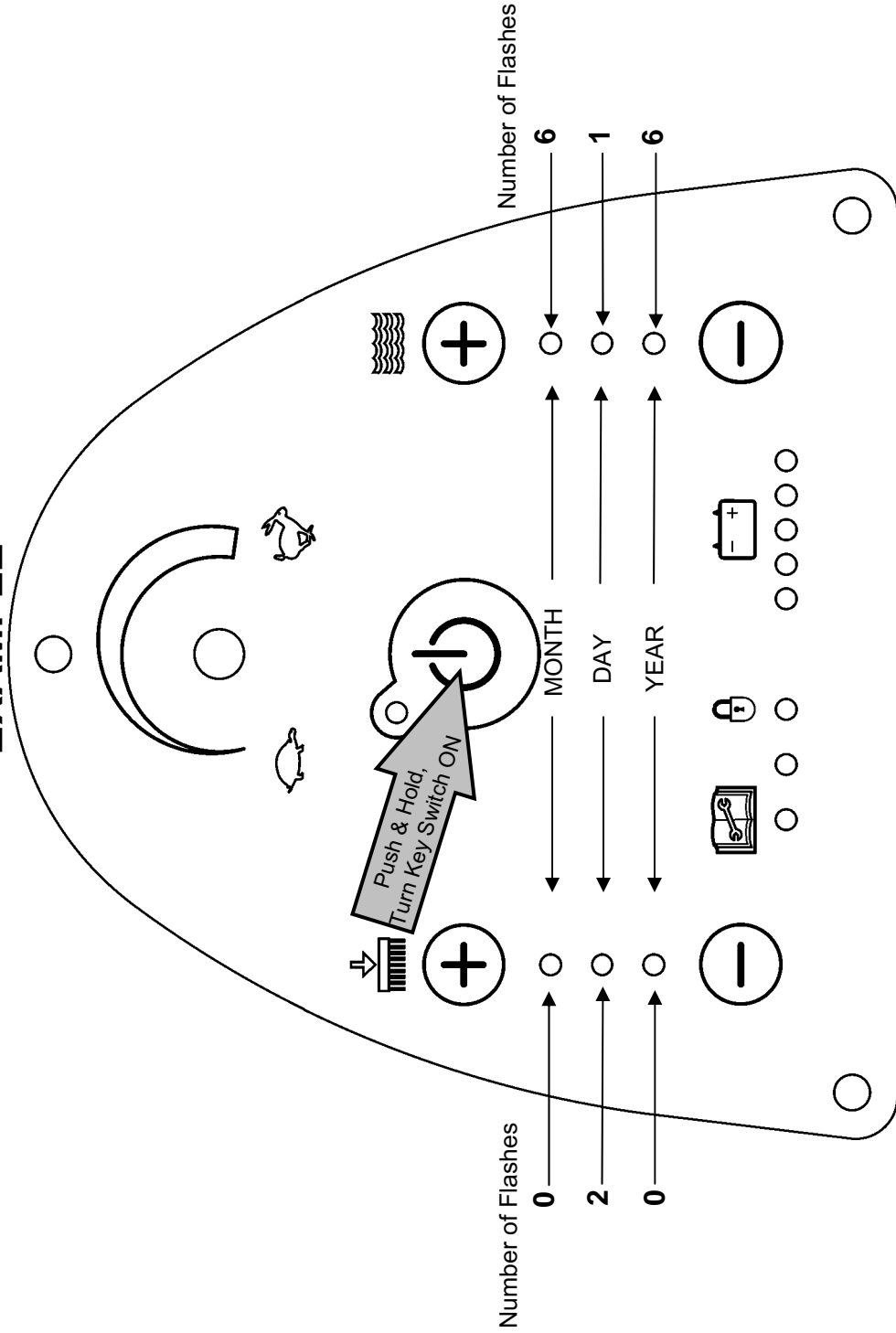

T5 – Self Test Mode

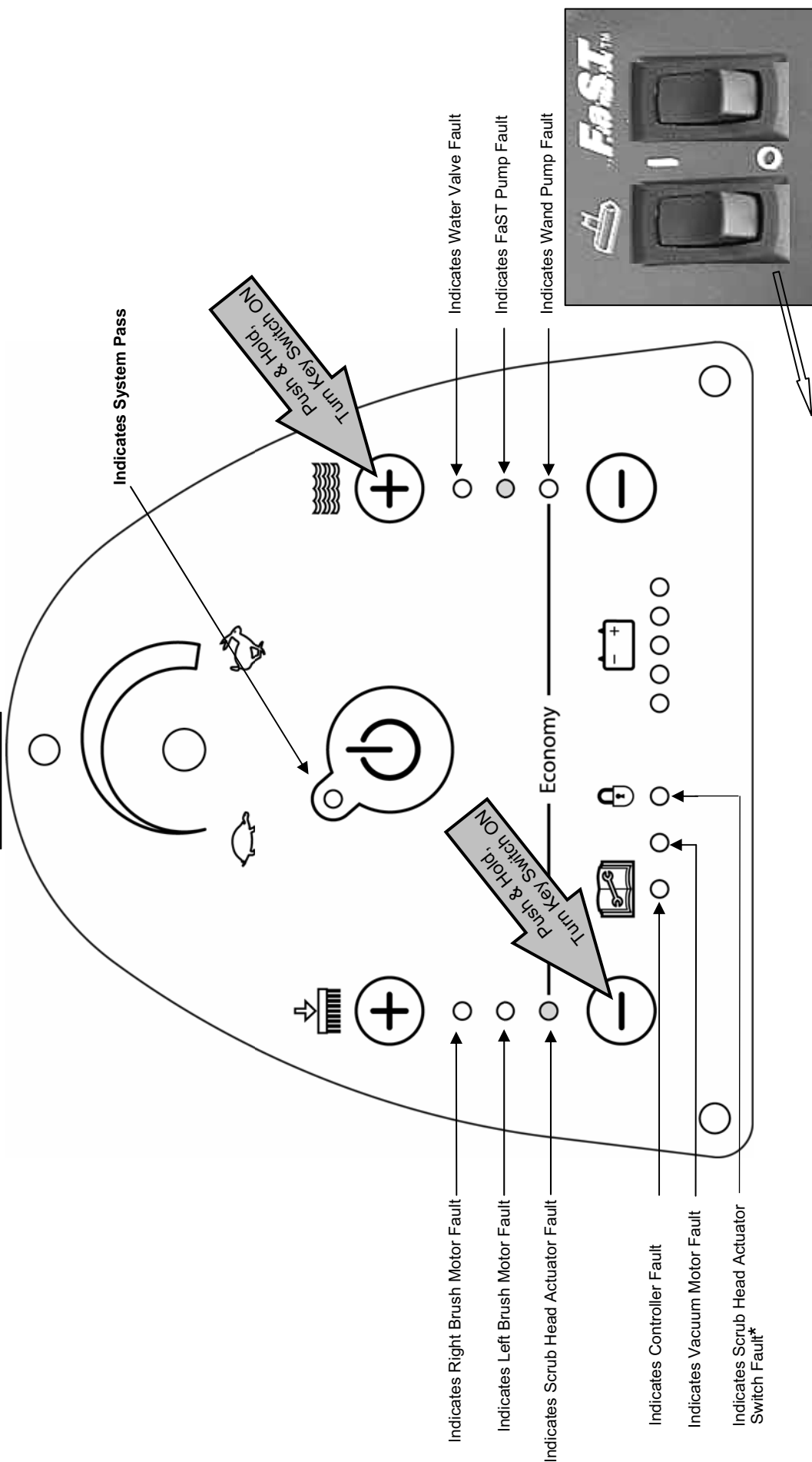

Note: If Optional FaST and/or Wand Pump are installed, each switch must be in the ON position before entering Self-Test Mode. If FaST or Wand Pump switches are in the OFF position when entering Self-Test Mode, that circuit will not be tested.

1. Hold the (-) Down pressure and (+) Increase Water buttons simultaneously on start-up. Machine will perform Self-Test for about 30-40 seconds.
2. After the self-test, either the One-Step Button LED will be lit solid to indicate system OK, or another panel LED will be flashing (which means OPEN fault) or solid lit LED (which means a SHORT fault) to indicate a system failure.

* **FAULT LED # 3:** Flashing indicates an actuator stall during retract. Solid LED on indicates a retract timeout error, or a mid-stroke switch fault.

In the example above, a blinking Low Down Pressure LED would indicate an open in the Scrub Head Actuator circuit. A solid Medium Solution LED would indicate a short in the FaST Pump circuit.

T5 – Input Display Mode

(Page 1 of 2)

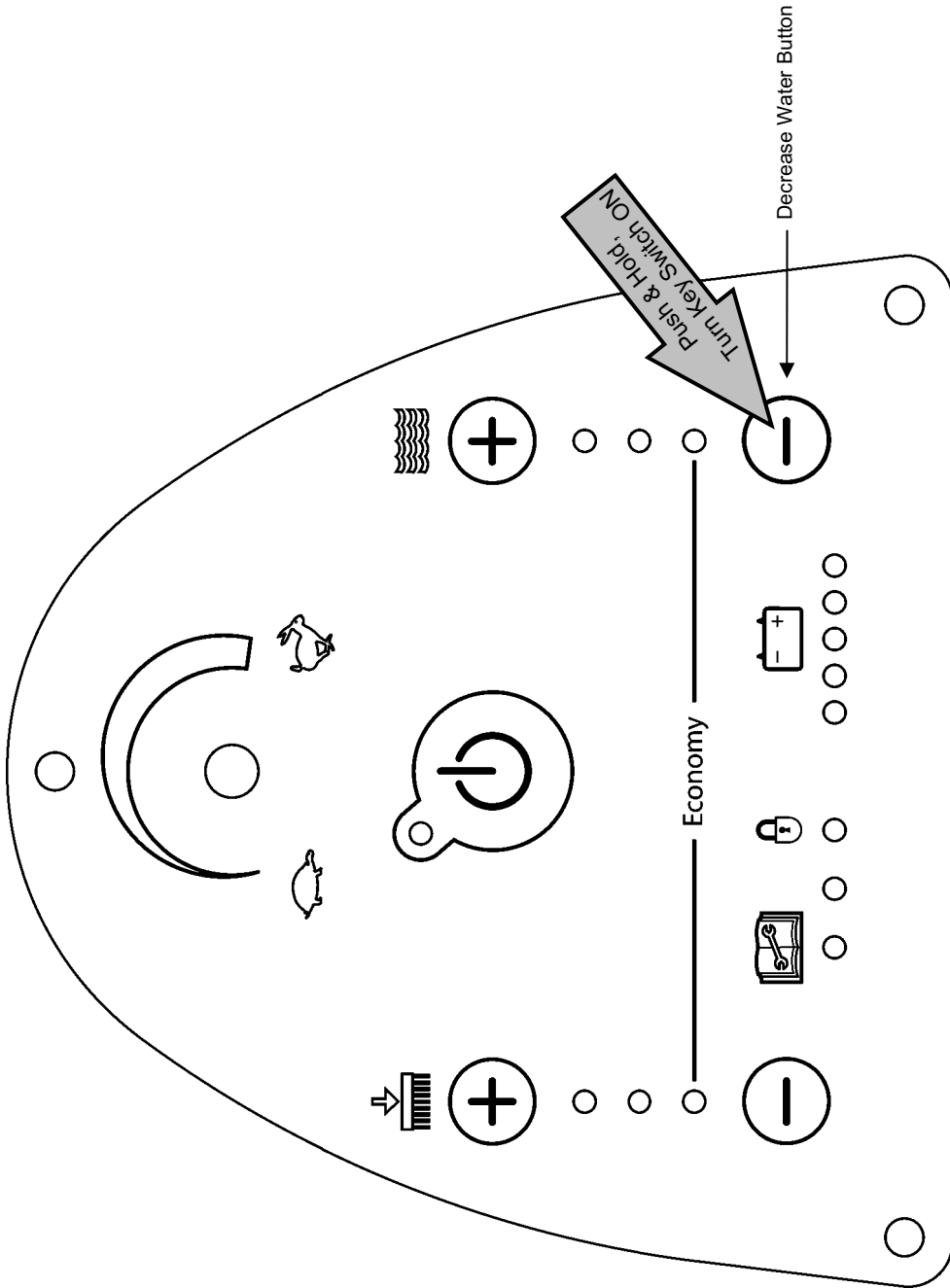

The purpose of the Input Display Mode is to show the condition of the different control board inputs. A description of the machine's operation in Input Display Mode is described below.

To enter the Input Display Mode:

Press and hold the Decrease Water (-) button and then turn on the key switch.





T5 – Input Display Mode

(Page 2 of 2)

When in the Input Display Mode, the following input conditions will be associated with the following LED's:

- One Step LED is on. = One Step Button on; scrub is active.
- Fault LED 1 is on. = E-stop Switch is open.
- Fault LED 2 is on = Vacuum Fan is active.
- Fault LED 3 is on. = Charger Interlock Switch is closed; charger is not plugged-in.
- Battery LED # 1 is on. = Actuator Retract Switch is closed; actuator is not in the retract (parked) position.
- Battery LED #2 is on. = Actuator Mid-Stroke Switch is closed; actuator has been extended at least two inches.
- Battery LED 3 is on. = FaST Switch is closed.
- Battery LED 4 is on. = Propel Interlock Switch is closed; recovery tank is down.
- Battery LED 5 is on. = Wand Pump Switch is closed.
- Brush Down Pressure LED's = Left Scrub Brush Pressure. Scrub Brush Down Pressure LED's indicate low, medium, & high pressure.
- Water Flow LED's = Right Scrub Brush Pressure. Water Flow LED's indicate low, medium, & high pressure.

T5 – Manual Mode

(Page 1 of 2)

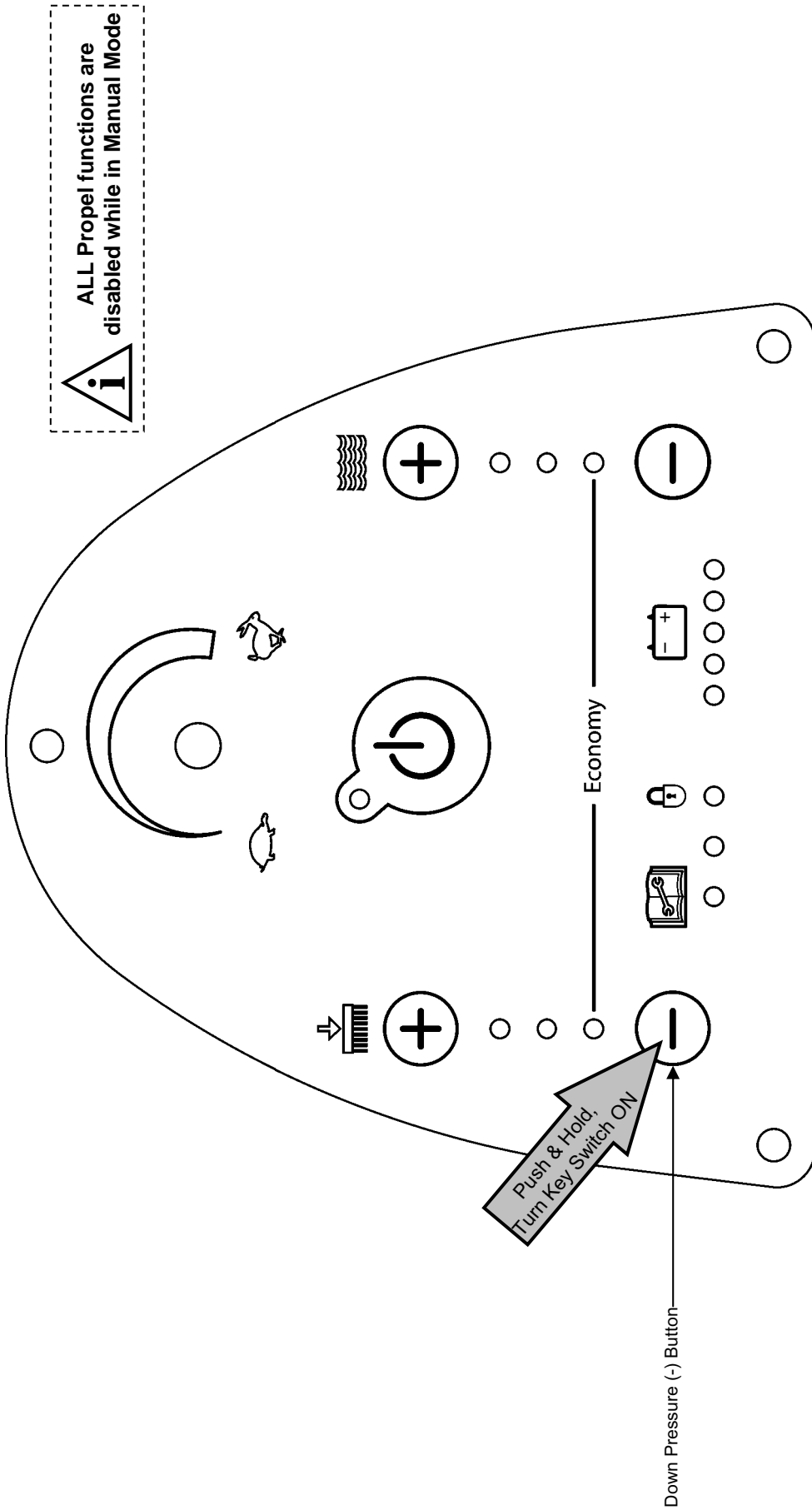

In Manual Mode, all of the Normal mode interlocks except for E-stop, and charger interlock are disabled. **All Propel functions are disabled in Manual Mode.** The purpose of the Manual Mode is to allow the technician to exercise individual scrub functions on the machine. **Extreme care must be exercised when operating the machine in this mode. (Note: there is no brush head pressure control in this mode)**

To enter the Manual Mode:

- Press and hold the Down Pressure (-) button and then turn on the key switch. Hold the button until the lowest brush pressure LED starts to blink, indicating that you're in Manual Mode.





T5 – Manual Mode

(Page 2 of 2)

While in Manual Mode:

- Pressing and holding the (+) Down Pressure button will lower the scrub head. The scrub head will continue to lower as long as the button is pressed, or until the actuator lower limit switch is opened. **(Note: there is no brush head pressure control in this mode)**
- Pressing and holding the (-) Down Pressure button will raise the scrub head. The scrub head will continue to rise as long as the button is pressed, or until the actuator upper limit switch is opened.
- Pressing and releasing the One Step button will toggle the brush motors on and off. When the One Step button is on, the One Step LED will light and both brush motors will turn on. When the One Step button is off, the One Step LED and both brush motors will turn off. **Caution: if you hold the (+) down pressure button on too long with the One Step button on, the Scrub Head assembly may make excessive contact with the floor, possibly damaging the floor surface.**
- Lowering the squeegee lift lever will activate the vacuum fan switch and turn on the vacuum fan.
- Raising the squeegee lift lever will deactivate the vacuum fan switch and turn off the vacuum fan after a 12 second delay.
- Turning on the FAST switch, will turn the FAST pump on, and disable the solution valve.
- Turning off the FAST switch, will turn the FAST pump off, and enable the solution valve.
- Pressing and releasing the (+) Water Flow button will increase the flow rate from the Solution valve. The Solution Flow LED's will indicate the solution valve setting (Off, Low, Medium, or High).
(Note: in this mode the Water-Flow-Auto-Off/On interlock is disabled)
- Pressing and releasing the (-) Water Flow button will decrease the flow rate from the Solution valve. The Solution Flow LED's will indicate the solution valve setting (Off, Low, Medium, or High).
- Turn key switch off to exit Manual Mode.

 **Do NOT hold the Increase Brush Pressure (+) too long – the Scrub Head may make excessive contact with the floor, possibly damaging the floor surface, Scrub Head actuator, or brush motors.**

 **ALL Propel functions are disabled while in Manual Mode**

T5 –Propel Diagnostics Mode

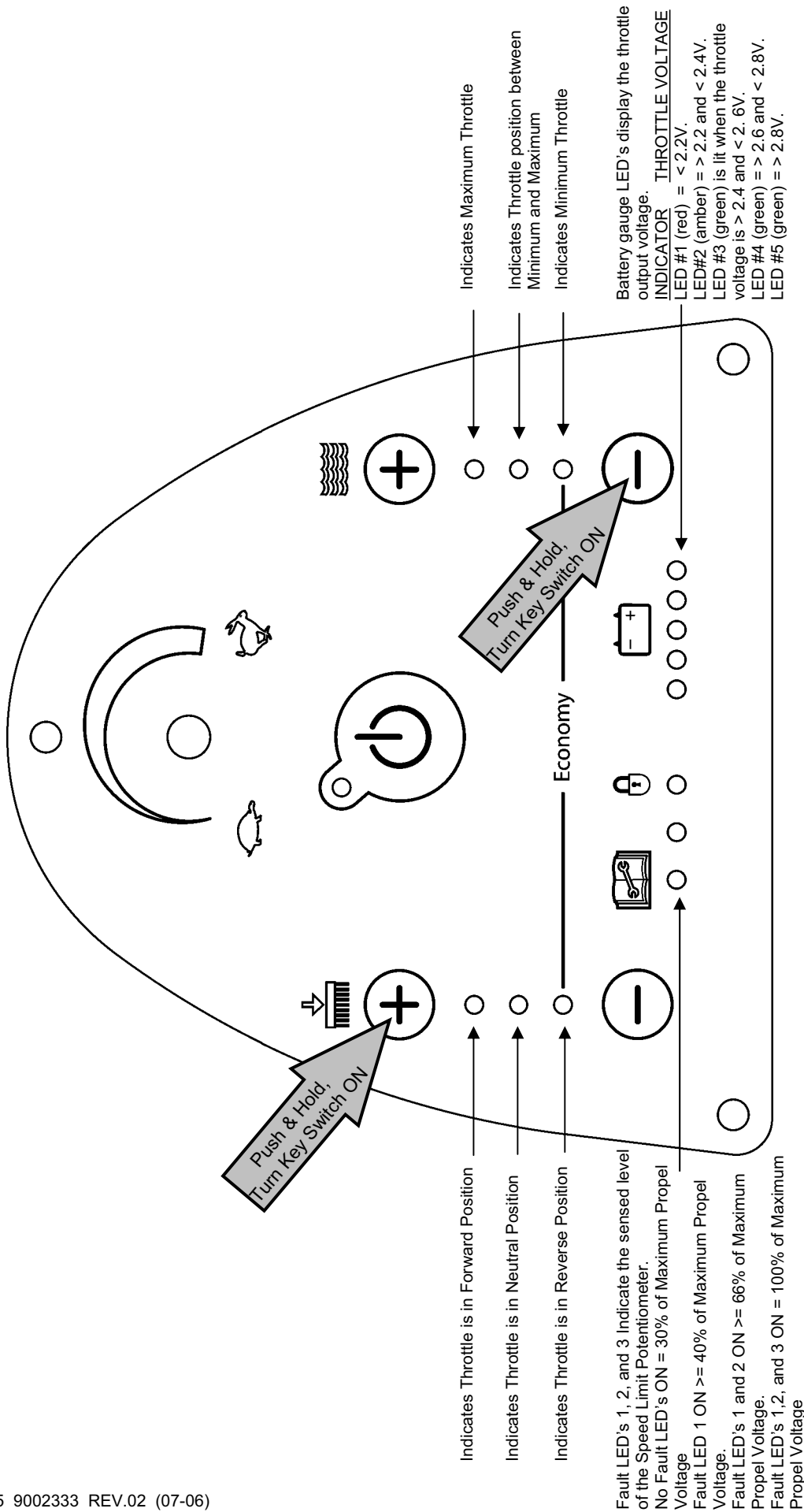

To Enter Propel Diagnostics Mode, simultaneously hold the (-) Decrease Water and (+) Increase Down Pressure buttons on power up. **Note: The Propel Motor is disabled in Propel Diagnostics Mode.**

The Down Pressure LED's indicate the throttle position, reverse, neutral, or forward. When the bail is not activated, Down Pressure LED #2 and Battery LED #3 (green) should be lit. This indicates that the throttle is in the center position and that the controller is sensing Neutral.

The Solution Level LED's indicate the sensed position of the throttle potentiometer between Min and Max in forward or reverse.

The Fault LED's indicate the sensed position of the Speed Limit Potentiometer (the speed control on the panel).



T5 – Battery Select Mode

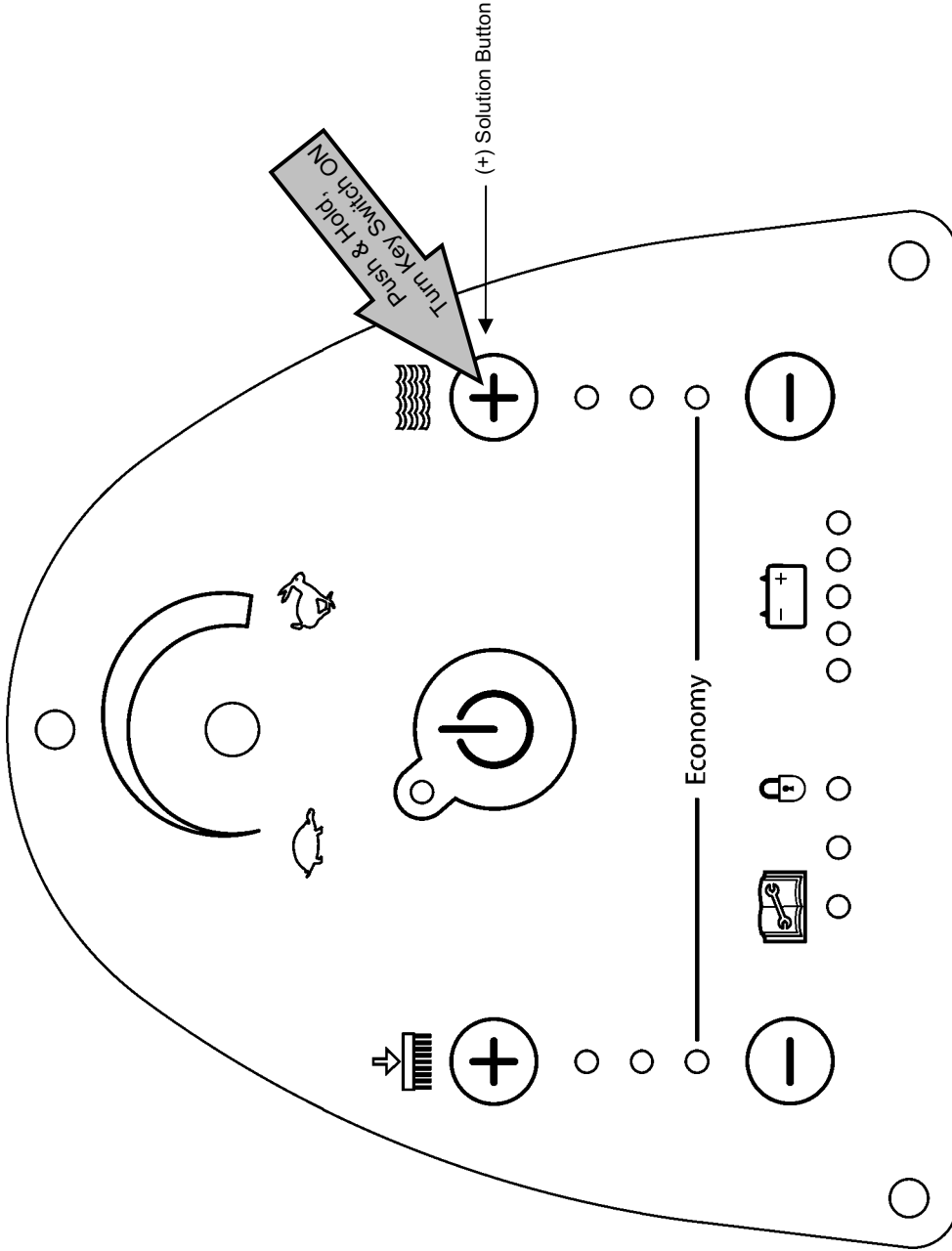

1. Power up holding the **SOLUTION (+)** key. Hold until one of the battery gauge LED's flashes.
2. Push the **SOLUTION (-)** key to select battery type. Matching this selection to the batteries in your machine is crucial for longest battery life.

First battery gauge LED (red) flashing	==	USA levels (default)
Second battery gauge LED (yellow) flashing	==	EU levels
Third battery gauge LED (green) flashing	==	TNV levels
Fourth battery gauge LED (green) flashing	==	GEL levels

3. Shut off machine, setting is stored.

T5 –Supervisor Mode

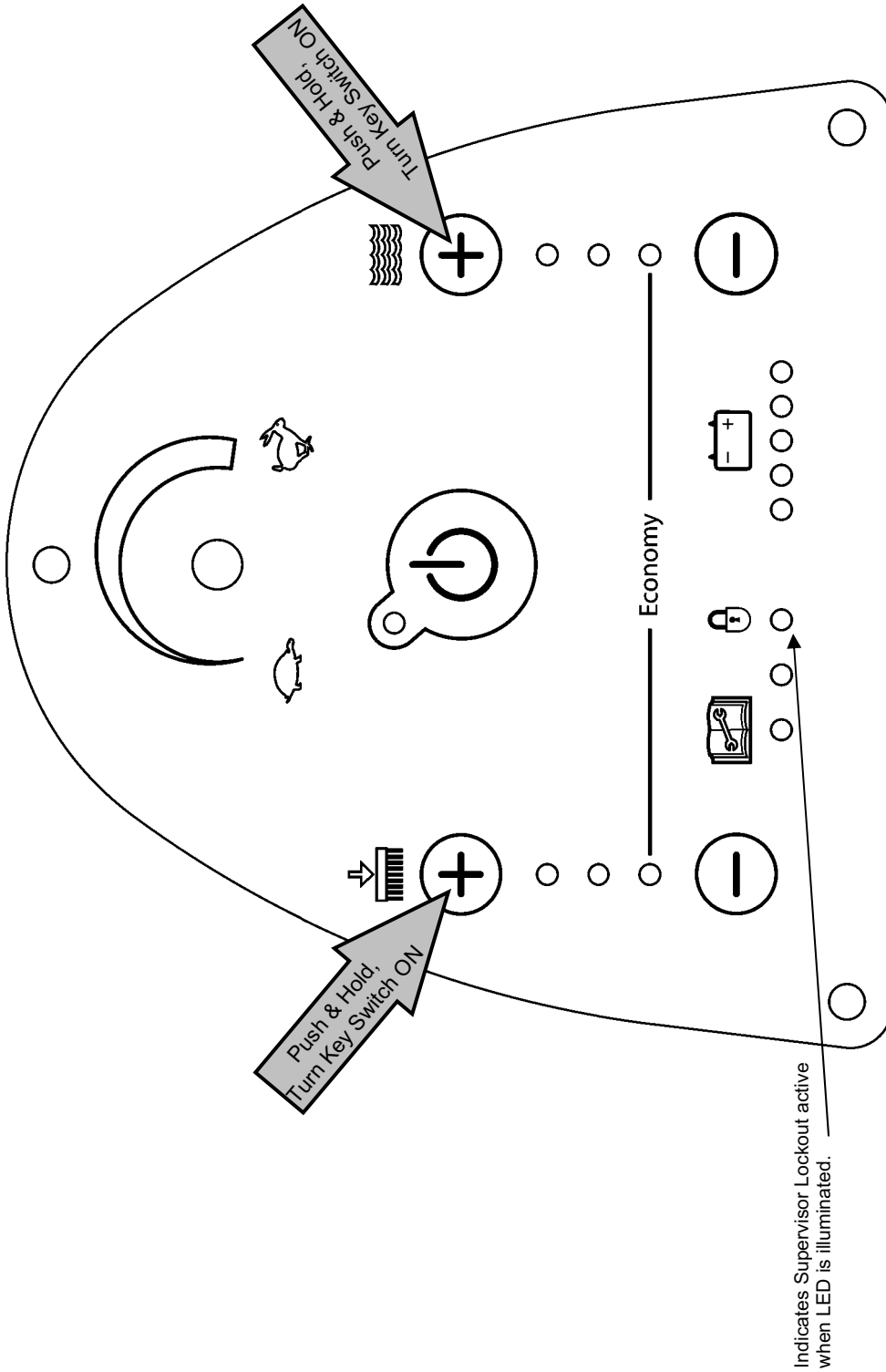

In Supervisor Mode the machine will function normally, but the Scrub Head Down Pressure, Solution Flow and FaST controls are locked out from the operator. Scrub Head Down Pressure, Solution Flow and FaST settings may be preset and locked into the machine. Once the setting is locked into memory it cannot be changed until the machine is toggled back out of Supervisor Mode.

1. Activate Supervisor Mode by holding both the Increase Down Pressure (+) button and the Increase Water (+) button down simultaneously during power up until battery LED 1 or 3 blinks four times.
 Battery LED 3 (Green) indicates that supervisor mode has been enabled. This will lock in the current Scrub Head Down Pressure, Solution Flow, and FaST settings.
 Battery LED 1 (Red) indicates that supervisor mode has been disabled. This will unlock the current Scrub Head Down Pressure, Solution Flow, and FaST settings, and allow the settings to be changed in Normal Mode.
2. Cycle the key switch to return to Normal Mode and observe Fault LED #3 (below padlock symbol).
 Fault LED 3 on indicates Supervisor Mode enabled. The LED will flash if a locked out button is pressed.
 Fault LED 3 off indicates Supervisor Mode disabled.



T5 – Scrub Propel Speed Selection Mode

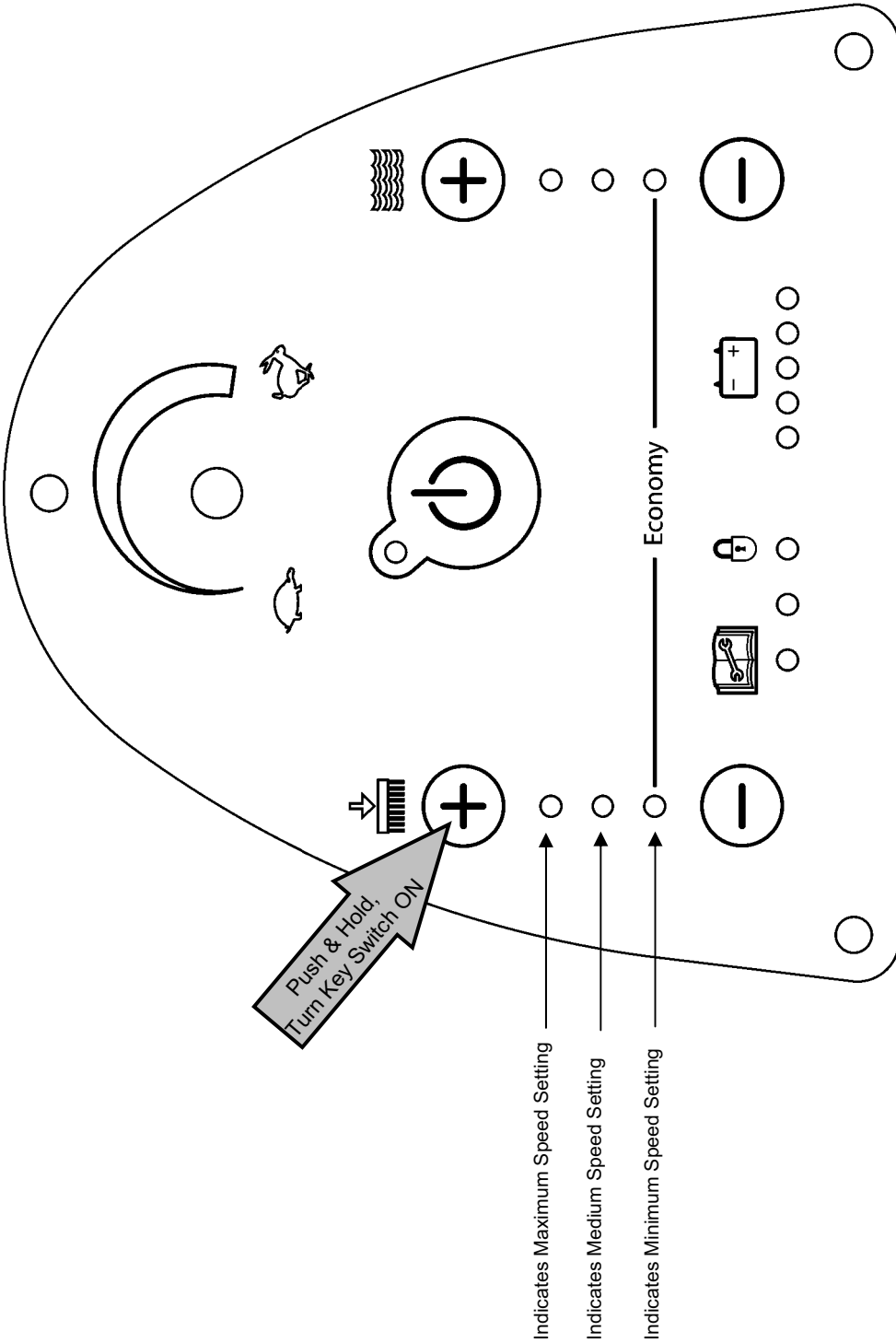

Enter Scrub Propel Speed Select Mode by holding down the Increase Down Pressure (+) button on Start up till you see the Down Pressure LED's illuminate. The Increase Down Pressure (+) and Decrease Down Pressure (-) buttons may be used to change the speed setting. Turn the key switch off to exit Scrub Propel Speed Select Mode. After the setting is changed it is maintained in non-volatile memory until changed.

Low Pressure LED represents Low Scrub Propel Speed Selection.

Medium Pressure LED represents Medium Scrub Propel Speed Selection.

High Pressure LED represents High Scrub Propel Speed Selection.

T5 – Scrub Head Selection Mode

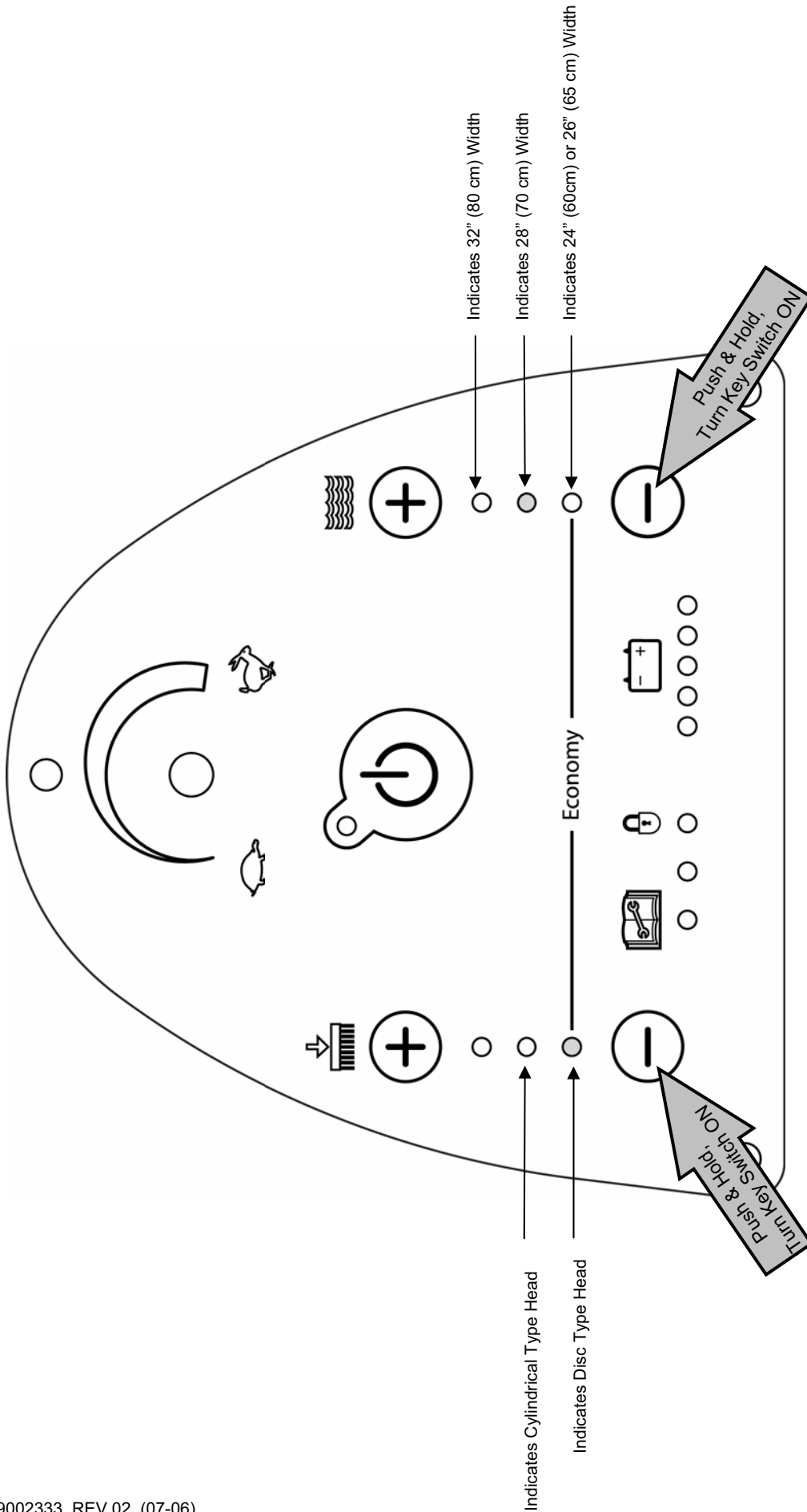

1. To enter Scrub Head Select Mode simultaneously hold down the Decrease Down Pressure (-) button and the Decrease Water (-) button when turning on the key switch. Hold the buttons until a Down Pressure LED and a Solution LED are illuminated. The current machine configuration is displayed. In the example above, the shaded LED's indicate that the machine is configured for a 28" (70cm) Disc Scrub Head. To exit Scrub Head Select Mode without changing the scrub head setting, turn the key switch off.
2. To change the scrub head setting, press and hold the One-Step button for five seconds until the One-step button starts to blink. Now, the Increase Down Pressure (+) button may be used to change the Scrub Head Type. The Increase Water (+) button may be used to change the Scrub Head Size. Each button press will increment the setting up to the next setting. Note: Only valid values will be allowed.
3. Turn the key switch off to lock the setting into memory.



T5 – Inputs & Outputs Table

Inputs and the Outputs they Control	Inputs											
	Key Switch (ON)	Throttle Input (Forward or Reverse)	Vacuum Switch (ON)	One Step Scrub Button (ON)	Low Voltage Interrupt	Charger Switch (Charger plugged in to machine)	Emergency Stop Switch (Pressed)	Recovery Tank Interlock Switch (Tank UP)	Supervisor Lockout	FaST Switch (ON)	FaST Switch (OFF)	Wand Switch (ON)
Main Contactor & Brake Relay	✓					X	X					
Propel Forward	✓	✓				X	X					
Propel Reverse	✓	✓				X	X					
Scrub Brush Motors	✓	✓		✓	X	X						
Scrub Head Pressure Control	✓	✓		✓	X	X		X**				
Vacuum Motor	✓		✓		X***	X						
FaST Pump	✓	✓		✓	X	X		X**	✓	X		
Conventional Solenoid Valve	✓	✓		✓	X	X			X	✓		
Solution Flow Control	✓	✓		✓	X	X		X**	X	✓		
Battery Charge Indicator	✓					X						
Wand Pump	✓					X						✓
Hour Meter	✓	✓*	✓*			X						



= Input that will ENABLE Output



= Input that will DISABLE Output

* Vacuum Fan and/or Propel will enable the Hour Meter

** Activated by pressing a combination of buttons on Touch Panel

*** Cycle Vacuum switch OFF/ON for an additional minute of vacuum motor operation