



Sidewinder BP 30

36.00.28

- ① USA Spare parts catalogue
- ② E Catalogo repuestos
- ③ F Catalogue des pièces de rechange
- ④ D Ersatzteilkatalog
- ⑤ I Catalogo parti di ricambio







Sidewinder BP30



- USA** Spare parts catalogue
- E** Catalogo repuestos
- F** Catalogue des pièces de rechange
- D** Ersatzteilkatalog
- I** Catalogo parti di ricambio



Specifications for ordering spare parts

- 1- SERIAL NUMBER AND MOTORSWEEPER TYPE.
- 2- NUMBER OF THE SPARE PARTS TABLE.
- 3- PART IDENTIFICATION CODE.
- 4- QUANTITY ORDERED.

EXAMPLE:

SIDEWINDER BP30

Table: 1

Item: 1 (6297271 - carbon brushes kit)

Q.ty: 1 Pcs.

Especificaciones por pedir piezas de repuesto

- 1- NÚMERO DE SERIE Y TIPO DE MOTOESCOBA.
- 2- NÚMERO DE LA MESA DE LAS PIECES DE REPUESTO.
- 3- CÓDIGO DE IDENTIFICACIÓN DE PARTE.
- 4- CANTIDAD PEDIDA.

EJEMPLO:

SIDEWINDER BP30

Mesa: 1

Artículo: 1 (6292071 - serie carbonillo)

Q.ty: 1 Pcs

Données à indiquer pour la commande des pièces de rechange

- 1 -NUMERO DE MATRICULE ET TYPE DE LA BALAYEUSE.
- 2 -NUMERO DE LA TABLE DES PIECES DE RECHANGE.
- 3 -NUMERO DE REFERENCE DE LA PIECE.
- 4 -QUANTITÉ COMMANDEE.

EXEMPLE:

SIDEWINDER BP30

Table: 1

Ligne: 1 (6297271 - jeu de balais au carbon)

Q.té: 1 Pièce.

Bei der Bestellung von Ersatzteilen unbedingt anzugeben

- 1 -FABRIKNUMMER UND KEHRMASCHINENTYP.
- 2 -NUMMER DER ERSATZTEILTAFEL.
- 3 -BEZUGSNUMMER DES ERSATZTEILES.
- 4 -BESTELLTE MENGE.

BEISPIEL:

SIDEWINDER BP30

Tafel: 1

Zeile: 1 (6297271 - kohlenbürstensatz)

Menge: 1 Pièce.

Norme da osservare per l'ordinazione delle parti di ricambio

- 1 -NUMERO DI MATRICOLA E TIPO DI MOTOSCOPIA
- 2 -NUMERO DELLA TAVOLA RICAMBI.
- 3 -NUMERO DI RIFERIMENTO DEL PARTICOLARE.
- 4 -QUANTITÀ RICHIESTA.

ESEMPIO:

SIDEWINDER BP30

Tavola: 1

Voce: 1 (6297271 - serie carboncini)

Q.tà: 1 Pz.

Name plate
Typeplate del motor-barrendero
Plaque d'identification du type de la balayeuse
Typenschild der Kehrmaschine
Targhetta riassuntiva del tipo di motoscopa

NSS Enterprises, Inc. 3115 FRENCHMENS ROAD, TOLEDO, OH 43607-2968			
SWEEPER			
MODEL	SIDEWINDER BP 30	WEIGHT	131
SERIAL N°	142627	YEAR	2001
37 A	12 V.DC		440 W
			FILTER TYPE U
HEAVY DUTY MACHINES FOR COMMERCIAL OR INDUSTRIAL USE.			

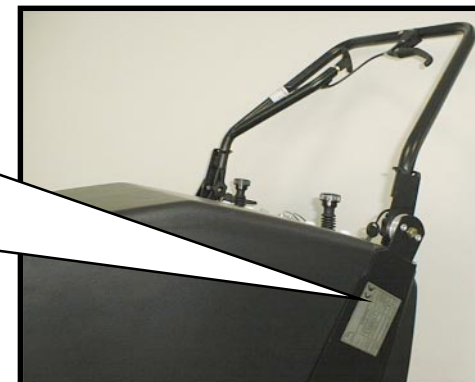



Table list

Lista de la mesa

Liste des tables

Tafelverzeichnis

Elenco delle tavole

<i>Table 1 Chassis, refuse container and bonnets</i>	<i>Mesa 1 Chasis, cajón portadesecho, cofre</i>	<i>Table 1 Chàssis, bac a déchets et capot</i>	<i>Tafel 1 Rabmengestell, Abfallbehälter, Haube</i>	<i>Tavola 1 Telaio, cassetto porta rifiuti, cofano</i>
<i>Table 2 Wheels and drive</i>	<i>Mesa 2 Ruedas y tracción</i>	<i>Table 2 Roues et traction</i>	<i>Tafel 2 Räder und Antrieb</i>	<i>Tavola 2 Ruote e trazione</i>
<i>Table 3 Main brush</i>	<i>Mesa 3 Cepillo central</i>	<i>Table 3 Balai central</i>	<i>Tafel 3 Hauptbürste</i>	<i>Tavola 3 Spazzola centrale</i>
<i>Table 4 Side brush</i>	<i>Mesa 4 Cepillo lateral</i>	<i>Table 4 Balai latéral</i>	<i>Tafel 4 Seltenbürste</i>	<i>Tavola 4 Spazzola laterale</i>
<i>Table 5 Suction filter, fan and flap</i>	<i>Mesa 5 Filtro de aspiración, ventilador, alerón</i>	<i>Table 5 Filtre d'aspiration, ventilateur et flap</i>	<i>Tafel 5 Ansaugfilter, Ventilator und Flap</i>	<i>Tavola 5 Filtro aspirazione, ventola e flap</i>
<i>Table 6 Electric motor and controls</i>	<i>Mesa 6 Motor eléctrico y mandos</i>	<i>Table 6 Moteur électrique et commandes</i>	<i>Tafel 6 Elektromotor und Steuer-elemente</i>	<i>Tavola 6 Motore elettrico e comandi</i>



Sidewinder BP30

Chassis, refuse container and bonnets
Chasis, cajón portadesecho, cofre
Châssis, bac à déchets et capot
Rabmengestell, Abfallbehälter, Haube
Telaio, cassetto porta rifiuti, cofano

Table
Tabla
Table
Tafel
Tavola

1

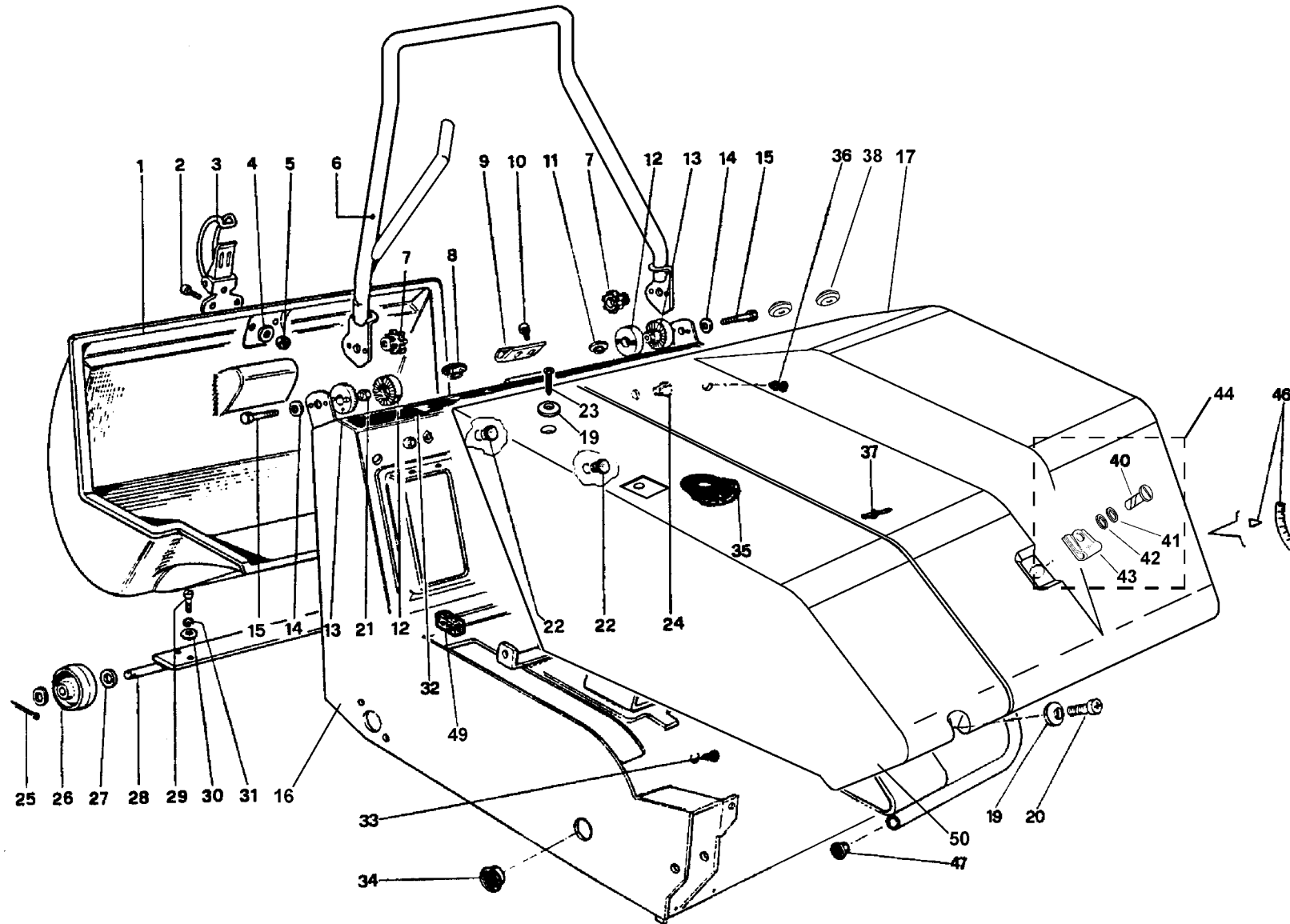

Item#	Part n°	Quantity	Description	Descripción	Description	Benennung	Descrizione	Remarks
Part n°	Código n°	Cantidad						Notas
N° piece	Code n°	Quantité						Notes
Stück Nr.	Code Nr.	Anzahl						Bemerkungen
Part. n°	Codice n°	Quantità						Note
1	6296481	1	refuse bin	cajón portadesecho	bac à déchets	Abfallbehälter	cassetto porta rifiuti	
2	6295621	2	allen head screw M5x16	tornillo T.C. M5x16	vis à tête cylindrique M5x16	Zylinderkopfschraube M5x16	vite T.C. M5x16	
3	6296281	1	lever closing	cierre de leva	levier de fermeture	Hebelverschluß	chiusura a leva	
4	6295451	2	washer ø 5	arandela ø 5	rondelle ø 5	Scheibe ø 5	rondella ø 5	
5	6295091	2	nut M5	tuerca M5	écrou M5	Mutter M5	dado M5	
6	6297261	1	handlebar	manillar	guidon	Lenkstange	manubrio	
7	6296371	2	handwheel	volante	volant	Handrad	volantino	
8	6296421	1	cap	tapón	bouchon	Stopfen	tappo	
9	6296991	1	hook	gancho	crochet	Haken	gancio	
10	6295631	2	self-tapping screw	tornillo autorroscante	vis autotaraudeuse	selbstschneidende Schraube	vite autofilettante	
11	6296461	1	cap	tapón	bouchon	Stopfen	tappo	
12	6297121	2	disk	plato	disque	Scheibe	disco	
13	6297131	2	disk	plato	disque	Scheibe	disco	
14	6295061	2	washer ø 8	arandela ø 8	rondelle ø 8	Scheibe ø 8	rondella ø 8	
15	6295511	2	Socked head screw M8x40	tornillo con cabeza curvada M8x40	vis à tête ronde M8x40	Rundkopfschraube M8x40	vite T.B.E.I M8x40	
16	6297281	1	chassis	chasis	châssis	Rahmengestell	telaio	
17	6296641	1	left motor hood	cofre izquierdo	capot gauche	linke Haube	cofano sinistro	
18	6297201	1	protection	protección	protection	Schutzstück	protezione	
19	6296561	2	washer	arandela	rondelle	Scheibe	rondella	
20	6295501	1	countersunk screw M6x16	tornillo T.S. M6x16	vis à tête fraisée M6x16	Senkschraube M6x16	vite T.S. M6x16	
21	6295131	2	nut M8	tuerca M8	écrou M8	Mutter M8	dado M8	
22	6296591	2	cap	tapón	bouchon	Stopfen	tappo	
23	6295491	1	countersunk screw M6x20	tornillo T.S. M6x20	vis à tête fraisée M6x20	Senkschraube M6x20	vite T.S. M6x20	
24	6296451	1	cap	tapón	bouchon	Stopfen	tappo	
25	6295231	2	split pin	clavija	goupille	Splint	copiglia	
26	6295811	2	wheel	rueda	roue	Rad	ruota	
27	6295061	4	washer ø 8x18x2	arandela ø 8x18x2	rondelle ø 8x18x2	Scheibe ø 8x18x2	rondella ø 8x18x2	
28	6297101	1	axle	eje	essieu	Achse	assale	
29	6295671	6	allen head screw M4x10	tornillo T.C. M4x10	vis à tête cylindrique M4x10	Zylinderkopfschraube M4x10	vite T.C. M4x10	
30	6295291	6	washer ø 4x9x1	arandela ø 4x9x1	rondelle ø 4x9x1	Scheibe ø 4x9x1	rondella ø 4x9x1	
31	6295271	6	spring washer ø 4	roseta ø 4	rondelle ø 4	Federscheibe ø 4	rosetta ø 4	
32	6296711	1	adhesive plate	plaquita adhesiva	plaque adhésive	Klebeschild	targhetta adesiva	
32	6296731	1	adhesive plate	plaquita adhesiva	plaque adhésive	Klebeschild	targhetta adesiva	
33	6296601	1	cap	tapón	bouchon	Stopfen	tappo	
34	6296441	1	cap	tapón	bouchon	Stopfen	tappo	
35	6296721	1	vacuum on/off label	plaquita adhesiva	plaque adhésive	Klebeschild	targhetta adesiva	
36	6296601	1	cap	tapón	bouchon	Stopfen	tappo	
37	6295591	3	rivet ø 4.8x12	remache ø 4.8x12	rivet ø 4.8x12	Niete ø 4.8x12	rivetto ø 4.8x12	
38	6297351	4	washer	arandela	rondelle	Scheibe	rondella	



Sidewinder BP30

Table
Tabla
Table
Tafel
Tavola

1



Sidewinder BP30

Chassis, refuse container and bonnets
Chasis, cajón portadesecho, cofre
Châssis, bac à déchets et capot
Rabmengestell, Abfallbehälter, Haube
Telaio, cassetto porta rifiuti, cofano

Table
Tabla
Table
Tafel
Tavola

1

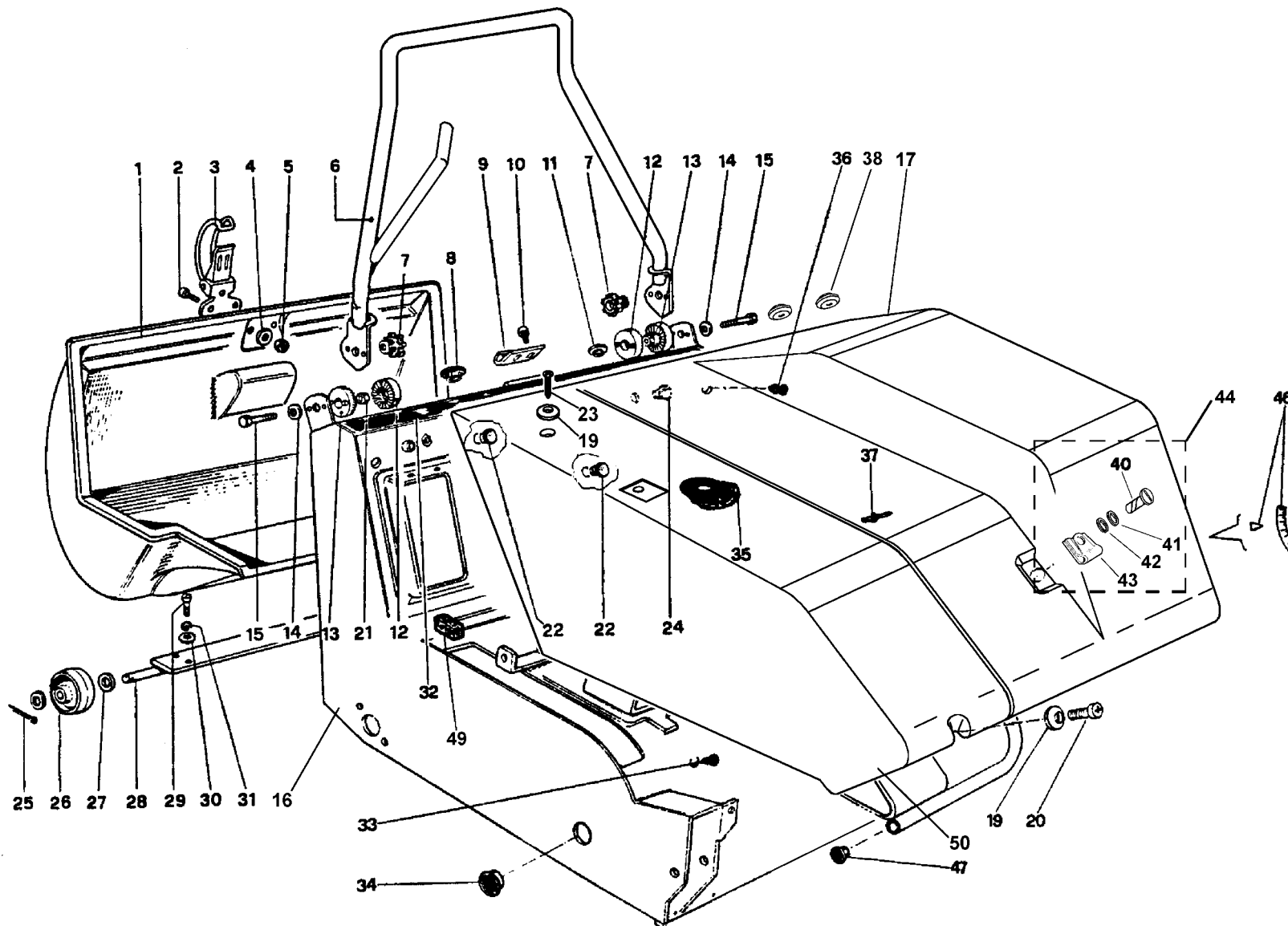

Item#	Part n°	Quantity	Description	Descripción	Description	Benennung	Descrizione	Remarks
Part#	Código n°	Cantidad						Notes
N° pièce	Code n°	Quantité						Notes
Stück Nr.	Code Nr.	Anzahl						Bemerkungen
Part. n°	Codice n°	Quantità						Note
39								
40	6297461	1	pin	pasador	pivot	Bolzen	perno	
41	6297491	1	washer	arandela	rondelle	Scheibe	rondella	
42	6297481	1	split-washer	arandela elástica	rondelle élastique	Federscheibe	rondella elastica	
43	6297471	1	plate, pin locking	placa que bloquea	plat de fermeture	Verriegelungsplatte	ricettacolo	
44	6296611	1	locking pin assembly	pasador completo	ensemble pivot	Komplett- bolzen	assieme perno	
45								
46	6296741	1	main brush label	plaquita adhesiva	plaquette adhésive	Klebeschild	adesivo	
47	6296461	1	cap	tapón	bouchon	Stopfen	tappo	
48	6295841	0,7"	rubber section	prefil engomado	profil en caoutchouc	Gummiprofil	profilo in gomma	
49								
50	6296631	1	right motor hood	cofre dierecho	capot droit	rechte Haube	cofano destro	



Sidewinder BP30

Table
Tabla
Table
Tafel
Tavola



Sidewinder BP30

Wheels and drive
Ruedas y tracción
Roues et traction
Räder und Antrieb
Ruote e trazione

Table
Tabla
Table
Tafel
Tavola

2

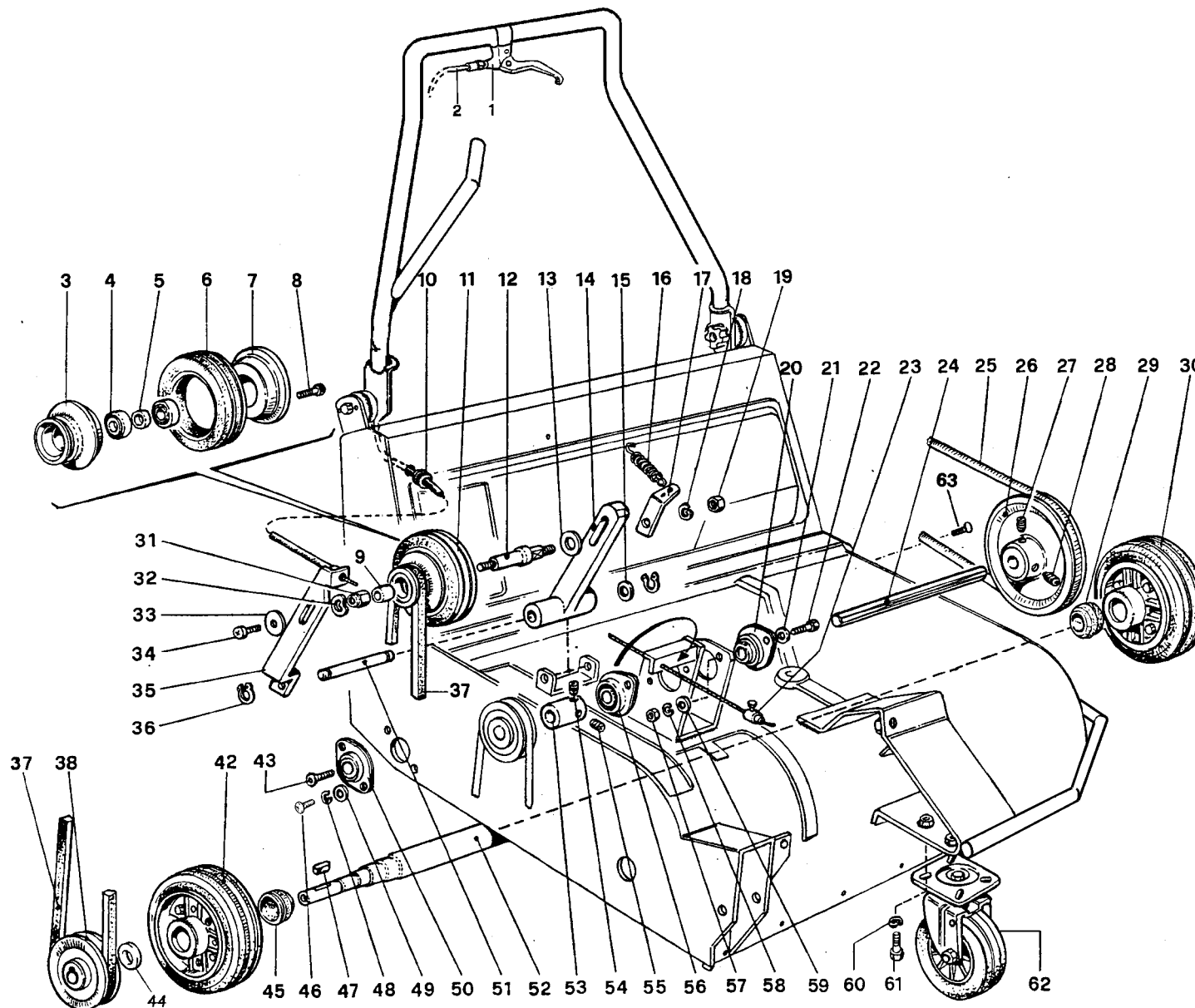

Item#	Part n°	Quantity	Description	Descripción	Description	Benennung	Descrizione	Remarks
Part n°	Código n°	Cantidad						Notas
N° piece	Code n°	Quantité						Notes
Stück Nr.	Code Nr.	Anzahl						Bemerkungen
Part. n°	Codice n°	Quantità						Note
1	6296341	1	drive handle	manilla de tracción	poignée traction	Antriebsgriff	maniglia trazione	
2	6296321	1	drive cable	cable de tracción	câble traction	Antriebskabel	cavo trazione	
3	6296401	1	pulley	polea	poulie	Riemenscheibe	puleggia	
4	6296221	2	bearing 10x30x9	rodamiento 10x30x9	roulement 10x30x9	Lager 10x30x9	cuscinetto 10x30x9	
5	6296681	1	spacer	separador	entretoise	Abstandhalter	distanziale	
6	6295781	1	rubber ring	anillo engomado	anneau en caoutchouc	Gummiring	anello gommato	
7	6296861	1	semi-disk	semitrato	demi-disque	Halbscheibe	semidisco	
8	6295211	4	allen-head screw M5x25	tornillo T.C. M5x25	vis à tête cylindrique M5x25	Zylinderkopfschraube M5x25	vite T.C. M5x25	
9	6296691	1	spacer	separador	entretoise	Abstandhalter	distanziale	
10	6295831	1	cable guide	anillo guíahilo	bague de guidage fil	Kabeldurchgang	anello passafilo	
11	6296821	1	drive wheel assembly	conjunto rueda de tracción	ensemble roue de traction	Antriebsrad, komplett	assieme ruota trazione	
12	6296801	1	shaft	eje	arbre	Welle	albero	
13	6295251	1	washer ø 12x24x2.5	arandela ø 12x24x2,5	rondelle ø 12x24x2,5	Scheibe ø 12x24x2,5	rondella ø 12x24x2,5	
14	6296781	1	rocker arm	balancear	culbuteur	Kipphebel	bilanciere	
15	6295121	1	washer ø 10	arandela ø 10	rondelle ø 10	Scheibe ø 10	rondella ø 10	
16	6296251	1	spring	resorte	ressort	Feder	molla	
17	6297181	1	plate	placa	plaque	Plättchen	piastrino	
18	6295321	1	spring washer ø 10	roseta ø 10	rondelle ø 10	Federscheibe ø 10	rosetta ø 10	
19	6295021	1	nut M10	tuerca M10	écrou M10	Mutter M10	dado M10	
20	6296241	1	support	soporte	support	Halterung	supporto	
21	6295041	4	washer ø 6	arandela ø 6	rondelle ø 6	Scheibe ø 6	rondella ø 6	
22	6295071	4	hexagonal head screw M6x16	tornillo T.E. M6x16	vis à tête à six pans M6x16	Sechskantschraube M6x16	vite T.E. M6x16	
23	6295391	1	clamp	terminal	collier	Klemme	morsetto	
24	6297011	1	shaft	eje	arbre	Welle	albero	
25	6295871	1	belt	correa	courroie	Riemen	cinghia	
26	6297041	1	pulley	polea	poulie	Riemenscheibe	puleggia	
27	6295201	1	flat end set screw	pasador (P.P.)	ergot à bout plat	Gewindestift mit Flachende	grano (P.P.)	
28	6295401	1	tapered end set screw	pasador (P.C)	ergot à bout conique	Gewindestift mit Spitzende	grano (P.C)	
29	6295761	1	V-ring	anillo	anneau en V	V-Ring	anello V-ring	
30	6295971	1	LH wheel assembly	conjunto rueda izquierda	ensemble roue gauche	linkes Rad, komplett	assieme ruota sx.	
31	6296771	1	nut	tuerca	écrou	Mutter	dado	
32	-	1	wave washer ø 10.5	arandela ondulata ø 10,5	rondelle ondulée ø 10,5	gewellte Scheibe ø 10,5	rondella ondulata ø 10,5	
33	6295101	1	washer ø 6x18x1.5	arandela ø 6x18x1,5	rondelle ø 6x18x1,5	Scheibe ø 6x18x1,5	rondella ø 6x18x1,5	
34	6295221	1	allen-head screw M6x8	tornillo T.C. M6x8	vis à tête cylindrique M6x8	Zylinderkopfschraube M6x8	vite T.C. M6x8	
35	6296831	1	lever	leva	levier	Hebel	leva	
36	6295431	2	stop ring e.ø 10	anillo de seguridad øe. 10	anneau d'arrêt øe. 10	Sperring e.ø 10	anello d'arresto øe. 10	
37	6295801	1	belt	correa	courroie	Riemen	cinghia	
38	6296761	1	pulley	polea	poulie	Riemenscheibe	puleggia	
39								
40								



Sidewinder BP30

Table
Tabla
Table
Tafel
Tavola



Sidewinder BP30

Wheels and drive
Ruedas y tracción
Roues et traction
Räder und Antrieb
Ruote e trazione

Table
Tabla
Table
Tafel
Tavola

2

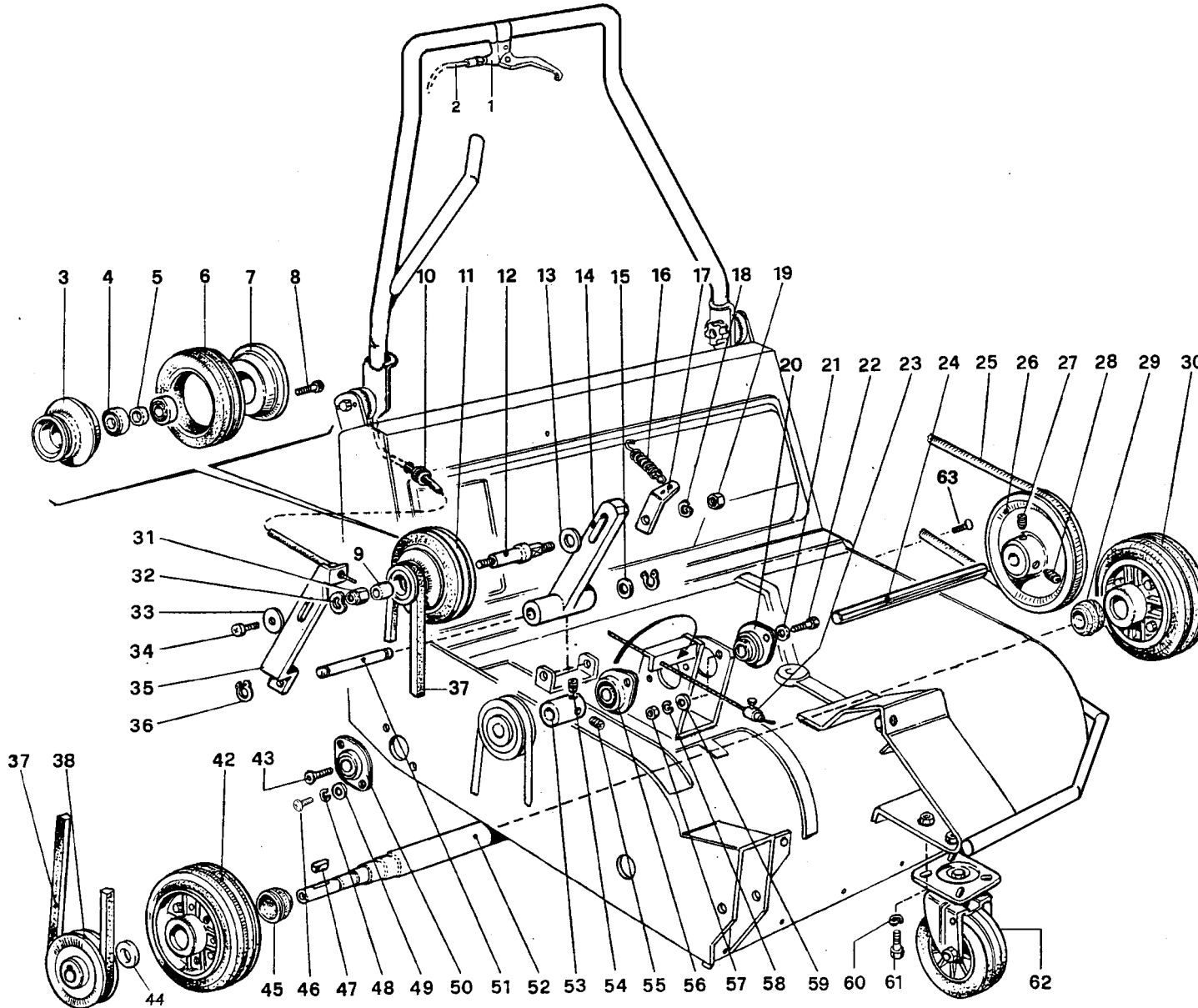

Item#	Part n°	Quantity	Description	Descripción	Description	Benennung	Descrizione	Remarks
Part n°	Código n°	Cantidad						Notes
N° pièce	Code n°	Quantité						Notes
Stück Nr.	Code Nr.	Anzahl						Bemerkungen
Part. n°	Codice n°	Quantità						Note
41								
42	6295961	1	RH wheel assembly	conjunto rueda derecha	ensemble roue droite	rechtes Rad, komplett	assieme ruota dx.	
43	6295751	1	countersunk screw M10x20	tornillo T.S. M10x20	vis à tête fraisée M10x20	Senkschraube M10x20	vite T.S. M10x20	
44	6296811	1	spacer	separador	entretoise	Abstandhalter	distanziale	
45	6295761	1	V-ring	anillo V-ring	anneau en V	V-Ring	anello V-ring	
46	6295071	4	socket head screw M6x18	tornillo con cabeza curvada. M6x18	vis à tête ronde M6x18	Rundkopfschraube M6x18	vite T.B.E. I M6x18	
47	6295241	1	key 6x6x12	lengueta 6x6x12	languette 6x6x12	Federkeil 6x6x12	lingueta 6x6x12	
48	6295111	4	spring washer ø 6	roseta ø 6	rondelle ø 6	Federscheibe ø 6	rosetta ø 6	
49	6295041	4	washer ø 6	arandela ø 6	rondelle ø 6	Scheibe ø 6	rondella ø 6	
50	6296211	2	wheel support	soporte ruedas	support roues	Radhalterung	supporto ruote	
51	6296791	1	spindle	eje	axe	kleine Welle	alberino	
52	6297091	1	shaft	eje	arbre	Welle	albero	
53	6296841	1	drive roller	rodillo tracción	rouleau de traction	Antriebsrolle	rullo trazione	
54	6295401	1	tapered end set screw	pasador (P.C.)	ergot à bout conique	Gewindestift mit Spitzende	grano (P.C.)	
55	6295201	1	flat end set screw	pasador (P.P.)	ergot à bout plat	Gewindestift mit Flachende	grano (P.P.)	
56	6296241	1	support	soporte	support	Halterung	supporto	
57	6295011	4	nut M6	tuerca M6	écrou M6	Mutter M6	dado M6	
58	6295111	4	spring washer ø 6	roseta ø 6	rondelle ø 6	Federscheibe ø 6	rosetta ø 6	
59	6295041	4	washer ø 6	arandela ø 6	rondelle ø 6	Scheibe ø 6	rondella ø 6	
60	6295151	4	spring washer ø 8	roseta ø 8	rondelle ø 8	Federscheibe ø 8	rosetta ø 8	
61	6295191	4	hexagonal head screw M8x16	tornillo T.E. M8x16	vis à tête à six pans M8x16	Sechskantschraube M8x16	vite T.E. M8x16	
62	6295821	4	front wheel	rueda anterior	roue avant	Vorderrad	ruota anteriore	
63	6295681	1	countersunk screw M10x20	tornillo T.S M10x20	vis à tête fraisée M10x20	Senkschraube M10x20	vite T.S M10x20	
64								
65								
66								
67								



Sidewinder BP30

Table
Tabla
Table
Tafel
Tavola



Sidewinder BP30

Main brush
Cepillo central
Balai central
Hauptbürste
Spazzola centrale

Table
Tabla
Table
Tafel
Tavola

3

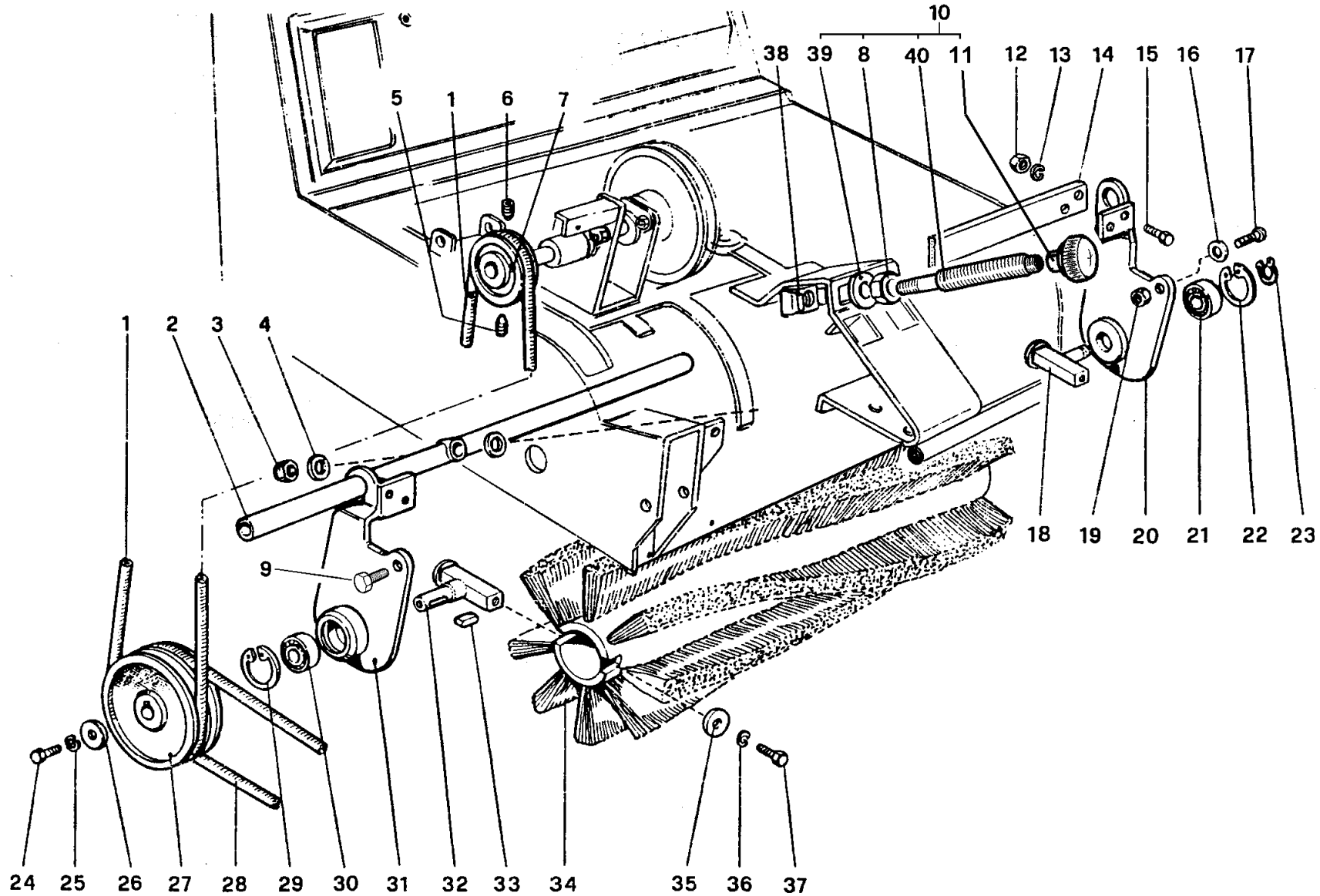

Item#	Part n°	Quantity	Description	Descripción	Description	Benennung	Descrizione	Remarks
Pezn#	Código n°	Cantidad						Notes
N° piece	Code n°	Quantité						Notes
Stück Nr.	Code Nr.	Anzahl						Bemerkungen
Part. n°	Codice n°	Quantità						Note
1	6295921	1	belt ø 10x800	correa ø 10x800	courroie ø 10x800	Riemen ø 10x800	cinghia ø 10x800	
2	6297271	1	adjusting pipe	tubo de registro	tuyau de réglage	Einstellrohr	tubo registro	
3	6295351	1	self-locking nut M8	tuerca de seguridad M8	écrou de sûreté M8	Sperrnut M8	dado autobloccante M8	
4	6295061	1	spring washer ø 8x18x2	arandela ø 8x18x2	rondelle ø 8x18x2	Scheibe ø 8x18x2	rondella ø 8x18x2	
5	6295201	1	flat end set screw M6x10	pasador M6x10 (P.P)	ergot M6x10 à bout plat	Gewindestift mit Flachende M6x10	grano M6x10 (P.P)	
6	6295401	1	tapered end set screw M6x10	pasador M6x10 (P.C.)	ergot M6x10 à bout conique	Gewindestift mit Spitzende M6x10	grano M6x10 (P.C.)	
7	6296851	1	pulley	polea	poulie	Riemenscheibe	puleggia	
8	6295311	1	nut M12	tuerca M12	écrou M12	Mutter M12	dado M12	
9	6296711	1	hexagonal head screw M8x18	tornillo T.E. M8x18	vis à tête à six pans M8x18	Sechskantschraube M8x18	vite T.E. M8x18	
10	6297221	1	brush adjustment with knob	ajuste del cepillo	réglage	Einstellung	registro spazzola	
11	6297391	1	knob	pomo	poignée	Knopf	volantino	
12	6295011	4	nut M6	tuerca M6	écrou M6	Mutter M6	dado M6	
13	6295111	4	spring washer ø 6	roseta ø 6	rondelle ø 6	Federscheibe ø 6	rosetta ø 6	
14	6297081	1	cross member	crucero	traverse	Querträger	traversa	
15	6295411	4	hexagonal head screw M6x20	tornillo T.E. M6x20	vis à tête à six pans M6x20	Sechskantschraube M6x20	vite T.E. M6x20	
16	6295061	2	washer ø 8x18x2	arandela ø 8x18x2	rondelle ø 8x18x2	Scheibe ø 8x18x2	rondella ø 8x18x2	
17	6295481	1	Socketed head screw M8x18	tornillo con cabeza curvada. M8x18	vis à tête ronde M8x18	Rundkopfschraube M8x18	vite T.B.E.I M8x18	
18	6296941	1	LH shaft	eje izquierdo.	arbre gauche	linke Welle	albero sx.	
19	6295351	2	self-locking nut M8	tuerca de seguridad M8	écrou de sûreté M8	Sperrnut M8	dado autobloccante M8	
20	6296891	1	LH side panel	costado izquierdo	flanc gauche	linkes Seitenstück	fianchetto sx.	
21	6296231	1	bearing ø 17x40x12	rodamiento ø 17x40x12	roulement ø 17x40x12	Lager ø 17x40x12	cuscinetto ø 17x40x12	
22	6295531	1	stop ring I.ø 40	anillo de seguridad øi. 40	anneau d'arrêt øi. 40	Sperring i.ø 40	anello di arresto øi. 40	
23	6295641	1	stop ring E.ø 17	anillo de seguridad øe. 17	anneau d'arrêt øe. 17	Sperring e.ø 17	anello di arresto øe. 17	
24	6295381	1	hexagonal head screw M8x12	tornillo T.E. M8x12	vis à tête à six pans M8x12	Sechskantschraube M8x12	vite T.E. M8x12	
25	6295151	1	spring washer ø 8	roseta ø 8	rondelle ø 8	Federscheibe ø 8	rosetta ø 8	
26	6295141	1	washer ø 8	arandela ø 8	rondelle ø 8	Scheibe ø 8	rondella ø 8	
27	6296961	1	pulley	polea	poulie	Riemenscheibe	puleggia	
28	6295881	1	belt ø 8x900	correa ø 8x900	courroie ø 8x900	Riemen ø 8x900	cinghia ø 8x900	
29	6295531	1	stop ring I.ø 40	anillo de seguridad øi. 40	anneau d'arrêt øi. 40	Sperring i.ø 40	anello di arresto øi. 40	
30	6296231	1	bearing ø 17x40x12	rodamiento ø 17x40x12	roulement ø 17x40x12	Lager ø 17x40x12	cuscinetto ø 17x40x12	
31	6296881	1	RH side panel	costado derecho	flanc droit	rechtes Seitenstück	fianchetto dx.	
32	6296951	1	RH shaft	eje derecho.	arbre droit	rechte Welle	albero dx.	
33	6295421	1	key 5x5x15	chaveta 5x5x15	clavette 5x5x15	Federkeil 5x5x15	chiavetta 5x5x15	
34	6296501	1	brush (white P.P.L. bristle ø 0.5)	cepillo (cerdas en P.P.L. blanche ø 0,5)	balai (soie blanche en P.P.L. ø 0,5)	Bürste (weiße Borsten aus P.P.L. ø 0,5)	spazzola (setole in P.P.L. bianche ø 0,5)	
34	6296511	1	brush (natural fiber)	cepillo	balai (fibre naturelle)	Bürste (Naturfaser)	spazzola (tampico)	
34	-							
34	6296531	1	brush (Nylon bristle)	cepillo (cerdas en nylon)	balai (soie Nylon)	Bürste (Borsten aus Nylon)	spazzola (setole in Nylon)	



Sidewinder BP30

Table
Tabla
Table
Tafel
Tavola



Sidewinder BP30

Main brush
Cepillo central
Balai central
Hauptbürste
Spazzola centrale

Table
Tabla
Table
Tafel
Tavola

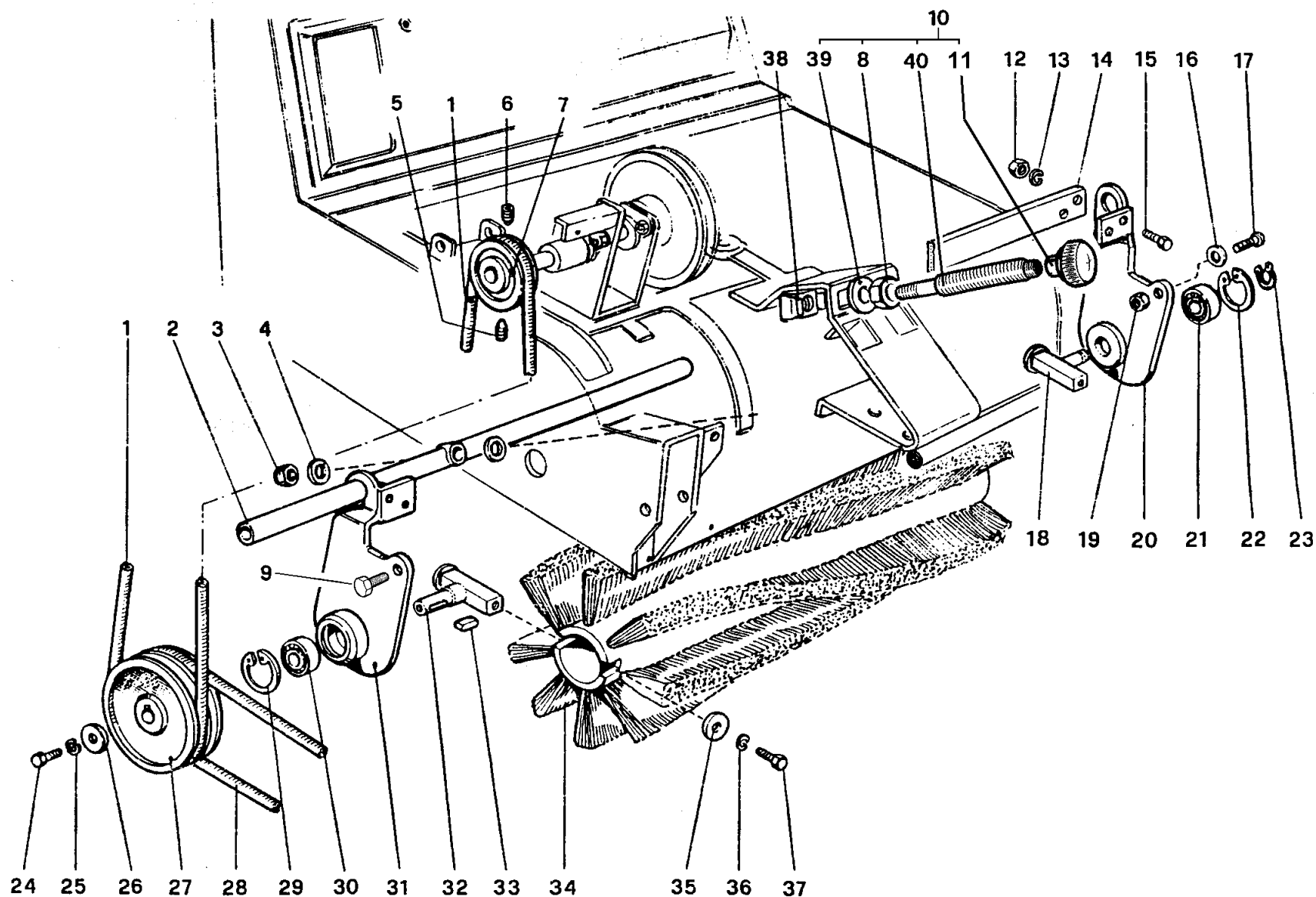



Sidewinder BP30

Side brush
Cepillo lateral
Balai latéral
Seltenbürste
Spazzola laterale

Table
Tabla
Table
Tafel
Tavola

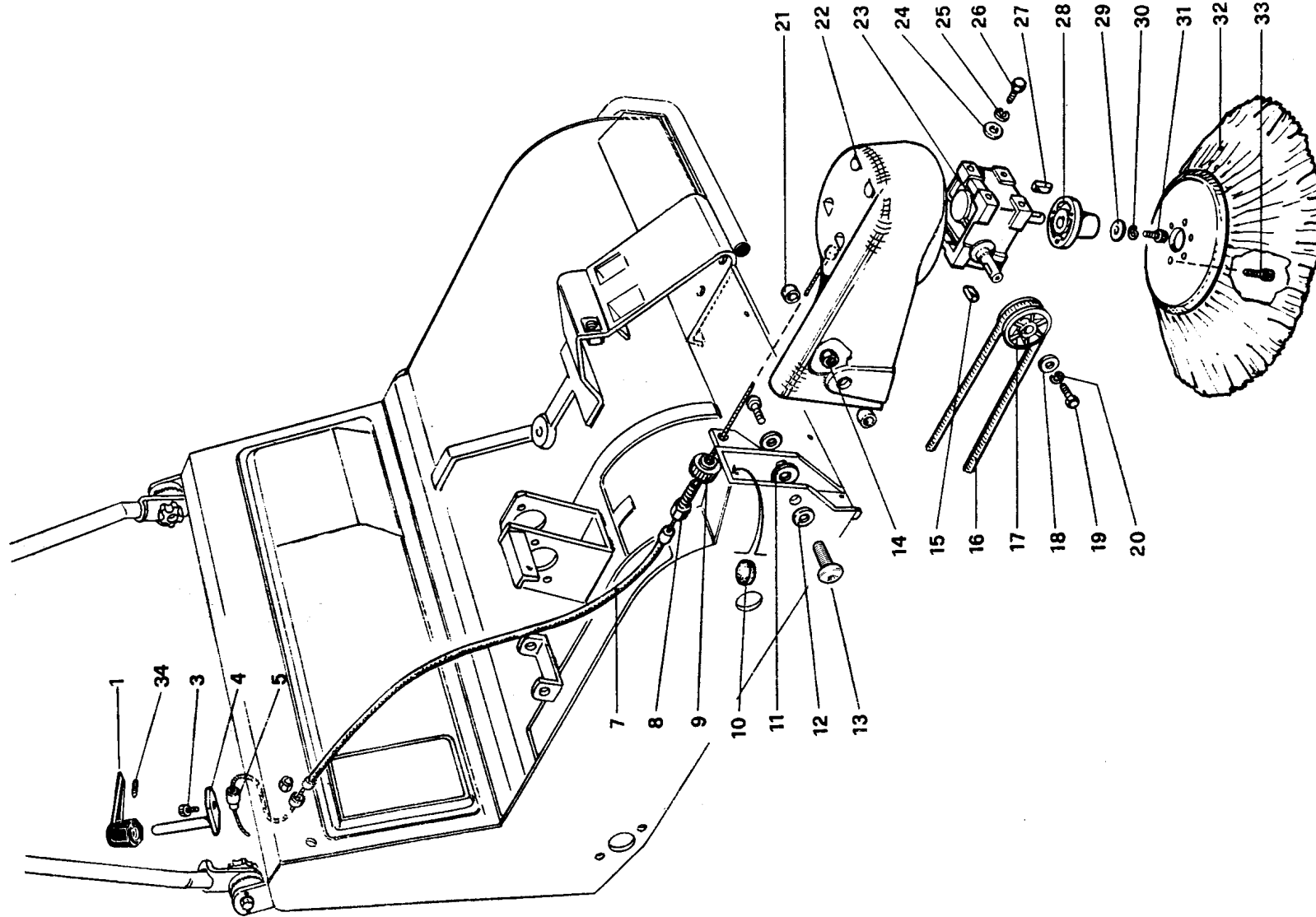

Item#	Part n°	Quantity	Description	Descripción	Description	Benennung	Descrizione	Remarks
Pieza n°	Código n°	Cantidad						Notas
N° pièce	Code n°	Quantité						Notes
Stück.Nr.	Code Nr.	Anzahl						Bemerkungen
Part.n°	Codice n°	Quantità						Note
1	6296651	1	handle	manilla	poignée	Handgriff	maniglia	
2	-							
3	6295581	1	hexagonal head screw M5x10	tornillo T.E. M5x10	vis à tête à six pans M5x10	Sechskantschraube M5x10	vite T.E. M5x10	
4	6297231	1	pin	tornillo	pivot	Bolzen	perno	
5	6295361	1	cable clamp	parado para cable	collier pour câble	Klemme	fermo per cavo	
6	-							
7	6296311	1	flexible cable	cable flexible	câble flexible	Bowdenkabel	cavo flessibile	
8	6295571	1	cable adjuster	registro para cable	pièce de réglage câble	Kabeleinstellung	registro cavo	
9	6297031	1	ring nut	casquillo	collier de serrage	Nutmutter	ghiera	
10	6295901	1	rubber stop	parado	butée en caoutchouc	Gummianschlag	fermo	
11	6295121	2	washer ø 10	arandela ø 10	rondelle ø 10	Scheibe ø 10	rondella ø 10	
12	6295061	2	washer ø 8x18x2	arandela ø 8x18x2	rondelle ø 8x18x2	Federscheibe ø 8x18x2	rondella ø 8x18x2	
13	6295051	2	socked head screw M8x20	tornillo con cabeza curvada. M8x20	vis à tête ronde M8x20	Rundkopfschraube M8x20	vite T.B.E.I M8x20	
14	6295351	2	nut M8	tuerca M8	écrou M8	Mutter M8	dado M8	
15	6295601	1	key 4x4x18	lengueta 4x4x18	languette 4x4x18	Federkeil 4x4x18	lingueta 4x4x18	
16	6295881	1	belt ø 8x900	correa ø 8x900	courroie ø 8x900	Riemen ø 8x900	cinghia ø 8x900	
17	6296381	1	pulley	polea	poulie	Riemenscheibe	puleggia	
18		1	washer ø 4x21x1	arandela ø 4x21x1	rondelle ø 4x21x1	Scheibe ø 4x21x1	rondella ø 4x21x1	
19	6295281	1	allen-head screw M4x10	tornillo T.C. M4x10	vis à tête cylindrique M4x10	Zylinderkopfschraube M4x10	vite T.C. M4x10	
20	6295271	1	spring washer ø 4	roseta ø 4	rondelle ø 4	Federscheibe ø 4	rosetta ø 4	
21	6297051	2	spacer	separador	entretoise	Abstandhalter	distanziale	
22	6296871	1	brush holder arm	brazo portacepillo	bras porte-balai	Bürstenhalter	braccio porta spazzola	
23	6296291	1	gear box	reductor	réducteur de vitesse	Untersetzungsgetriebe	riduttore	
24	6295041	4	washer ø 6	arandela ø 6	rondelle ø 6	Scheibe ø 6	rondella ø 6	
25	6295111	4	spring washer ø 6	roseta ø 6	rondelle ø 6	Federscheibe ø 6	rosetta ø 6	
26	6295071	4	hexagonal head screw M6x16	tornillo T.E. M6x16	vis à tête à six pans M6x16	Sechskantschraube M6x16	vite T.E. M6x16	
27	6295461	1	key 5x5x20	lengueta 5x5x20	languette 5x5x20	Federkeil 5x5x20	lingueta 5x5x20	
28	6296411	1	hub	cubo	moyeu	Nabe	mozzo	
29	6295101	1	washer ø 6	arandela ø 6	rondelle ø 6	Rondelle ø 6	rondella ø 6	
30	6295111	1	spring washer ø 6	roseta ø 6	rondelle ø 6	Unterlegscheibe ø 6	rosetta ø 6	
31	6295031	1	hexagonal head screw M6x12	tornillo T.E. M6x12	vis à tête à six pans M6x12	Sechskantschraube M6x12	vite T.E. M6x12	
32	6296391	1	side brush	cepillo lateral	balai latéral	Seitenbürste	spazzola laterale	
33	6295611	3	allen-head screw M6x18	tornillo T.C. M6x18	vis à tête cylindrique M6x18	Zylinderkopfschraube M6x18	vite T.C. M6x18	
34	6295731	1	set screw M4x14	pasador M4x14	ergot M4x14	Gewindestift M4x14	grano M4x14	



Sidewinder BP30

Table
Tabla
Table
Tafel
Tavola



Sidewinder BP30

Suction filter, fan and flap
Filtro de aspiración, ventilador, alerón
Filtre d'aspiration, ventilateur et flap
Ansaugfilter, Ventilator und Flap
Filtro aspirazione, ventola e flap

Table
Tabla
Table
Tafel
Tavola

5

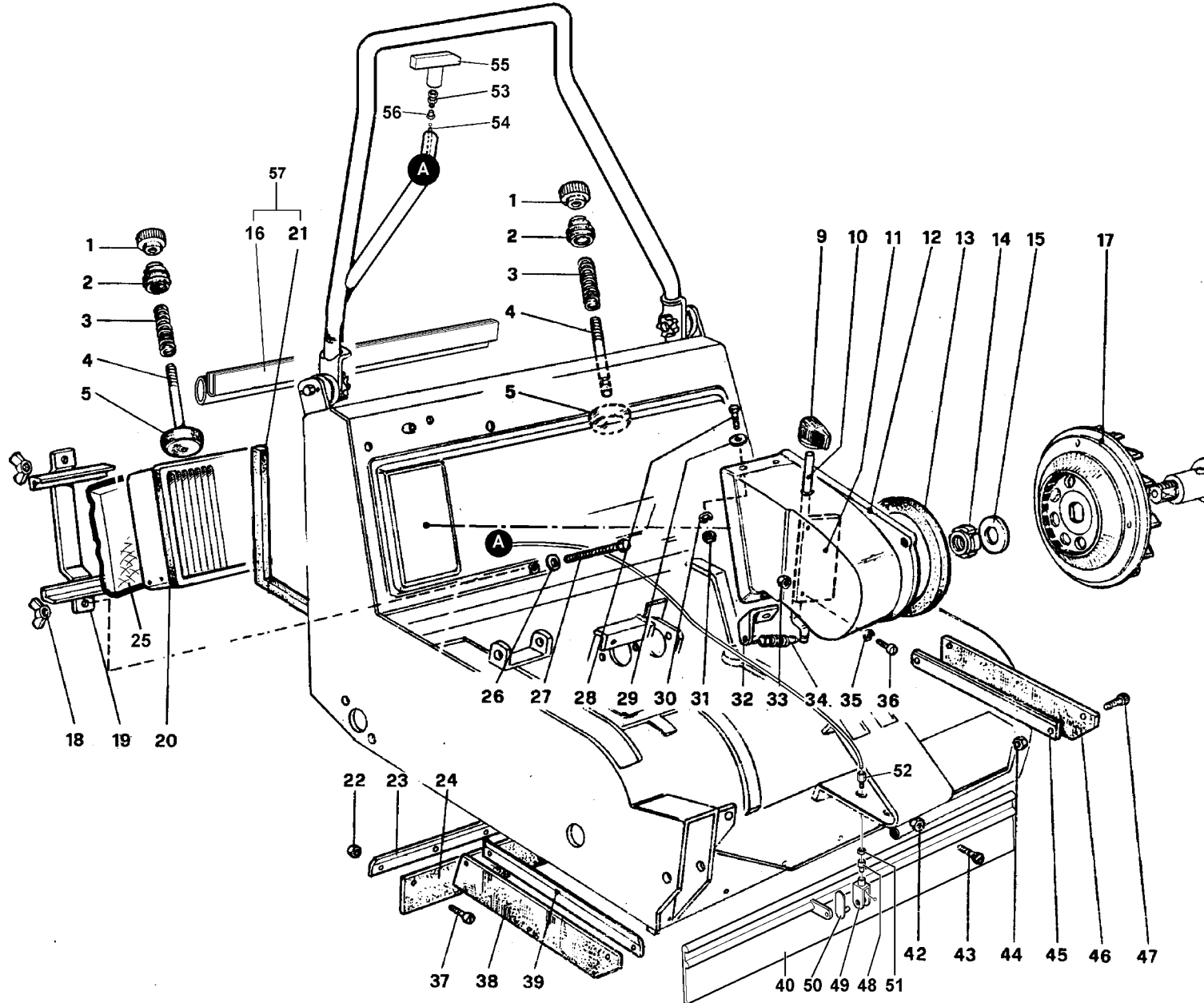

Item n°	Part n°	Quantity	Description	Descripción	Description	Benennung	Descrizione	Remarks
Pieza n°	Código n°	Cantidad						Notas
N° pièce	Code n°	Quantité						Notes
Stück Nr.	Code Nr.	Anzahl						Bemerkungen
Part. n°	Codice n°	Quantità						Note
1	6296431	2	knob	botón esférico	molette	Griff	pomello	
2	6295931	2	bellows	fuelle	soufflet	Faltenbalg	soffietto	
3	6296301	2	spring	resorte	ressort	Feder	molla	
4	6297001	2	tie-rod	tirante	tirant	Zugbolzen	tirante	
5	6296981	2	hammer	brazo de roptura	marteau	Hammer	martelletto	
6								
7								
8								
9	6296551	1	knob	empuñadura	poignée	Griff	manopola	
10	6297111	1	rod	asta	tige	Stab	asta	
11	6297241	1	plate	chapa	tôle	Blech	lamiera	
12	6296621	1	air sleeve	transportador aire	manchon à air	Luftleitkuppe	convogliatore aria	
13	6295951	1	rubber ring	anillo engomado	anneau en caoutchouc	Gummiring	anello gommato	
14	6295341	1	ring nut	casquillo	collier	Nutmutter	ghiera	
15	6295331	1	washer	arandela	rondelle	Scheibe	rondella	
16	6297431	mt 0,67	rubber section	profil de goma	profil en caotchouc	Gummiprofil	profilo in gomma	
17	6296141	1	suction fan	ventilador aspiración	ventilateur d'aspiration	Ansaugventilator	ventola aspirazione	
18	6295301	2	wing nut M6	tuerca de mariposa M6	écrou papillon M6	Fügelmutter M6	galletto M6	
19	6296921	1	filter fixing bracket	reten por filtro	bride de fixation filtre	Filterbügel	fermo per filtro	
21	6297421	1	sealing rubber 8x10x2020	goma adhesiva 8x10x2020	joint caoutchouc adhésif 8x10x2020	klebriger Gummistreifen 8x10x2020	gomma adesiva 8x10x2020	
22	6295091	6	nut M5	tuerca M5	écrou M5	Mutter M5	dado M5	
23	6297061	1	rubber section securing strip	placa de parada goma	bande fixation profil caotch.	Leiste Befest. Gummiprofil	piastrino ferma gomma	
24	6295911	1	rear rubber section	goma posterior	profil caoutchouc arrière	hinteres Gummiprofil	gomma posteriore	
25	6297451	1	prefilter	pre-filtro	pré-filtre	Vorfilter	velcro	
26	6295041	2	washer ø 6	arandela ø 6	rondelle ø 6	Scheibe ø 6	rondella ø 6	
27	6295691	2	hexagonal head screw M6x80	tornillo T.E. M6x80	vis à tête à six pans M6x80	Sechskantschraube M6x80	vite T.E. M6x80	
28	6295071	4	hexagonal head screw M6x16	tornillo T.E. M6x16	vis à tête à six pans M6x16	Sechskantschraube M6x16	vite T.E. M6x16	
29	6295041	4	washer ø 6	arandela ø 6	rondelle ø 6	Scheibe ø 6	rondella ø 6	
30	6295111	4	spring washer ø 6	roseta ø 6	rondelle ø 6	Federscheibe ø 6	rosetta ø 6	
31	6295011	4	nut M6	tuerca M6	écrou M6	Mutter M6	dado M6	
32	6297021	1	plate	placa	plaque	Plättchen	piastrino	
33	6295261	2	nut M4	tuerca M4	écrou M4	Mutter M4	dado M4	
34	6296251	1	spring	resorte	ressort	Feder	molla	
35	6295271	2	spring washer ø 4	roseta ø 4	rondelle ø 4	Federscheibe ø 4	rosetta ø 4	
36	6295521	2	allen-head screw M4x16	tornillo T.C. M4x16	vis à tête cylindrique M4x16	Zylinderkopfschraube M4x16	vite T.C. M4x16	
37	6295081	6	allen-head screw M5x12	tornillo T.C. M5x12	vis à tête cylindrique M5x12	Zylinderkopfschraube M5x12	vite T.C. M5x12	
38	6295861	1	side rubber section	goma lateral	profil caoutchouc latéral	seitliches Gummiprofil	gomma laterale	
39	6296971	1	rubber section securing strip	placa de parada goma	bande fixation profil caotch.	Leiste Befest. Gummiprofil	piastrino ferma gomma	



Sidewinder BP30

Table
Tabla
Table
Tafel
Tavola

5



Sidewinder BP30

Suction filter, fan and flap
Filtro de aspiración, ventilador, alerón
Filtre d'aspiration, ventilateur et flap
Ansaugfilter, Ventilator und Flap
Filtro aspirazione, ventola e flap

Table
Tabla
Table
Tafel
Tavola

5

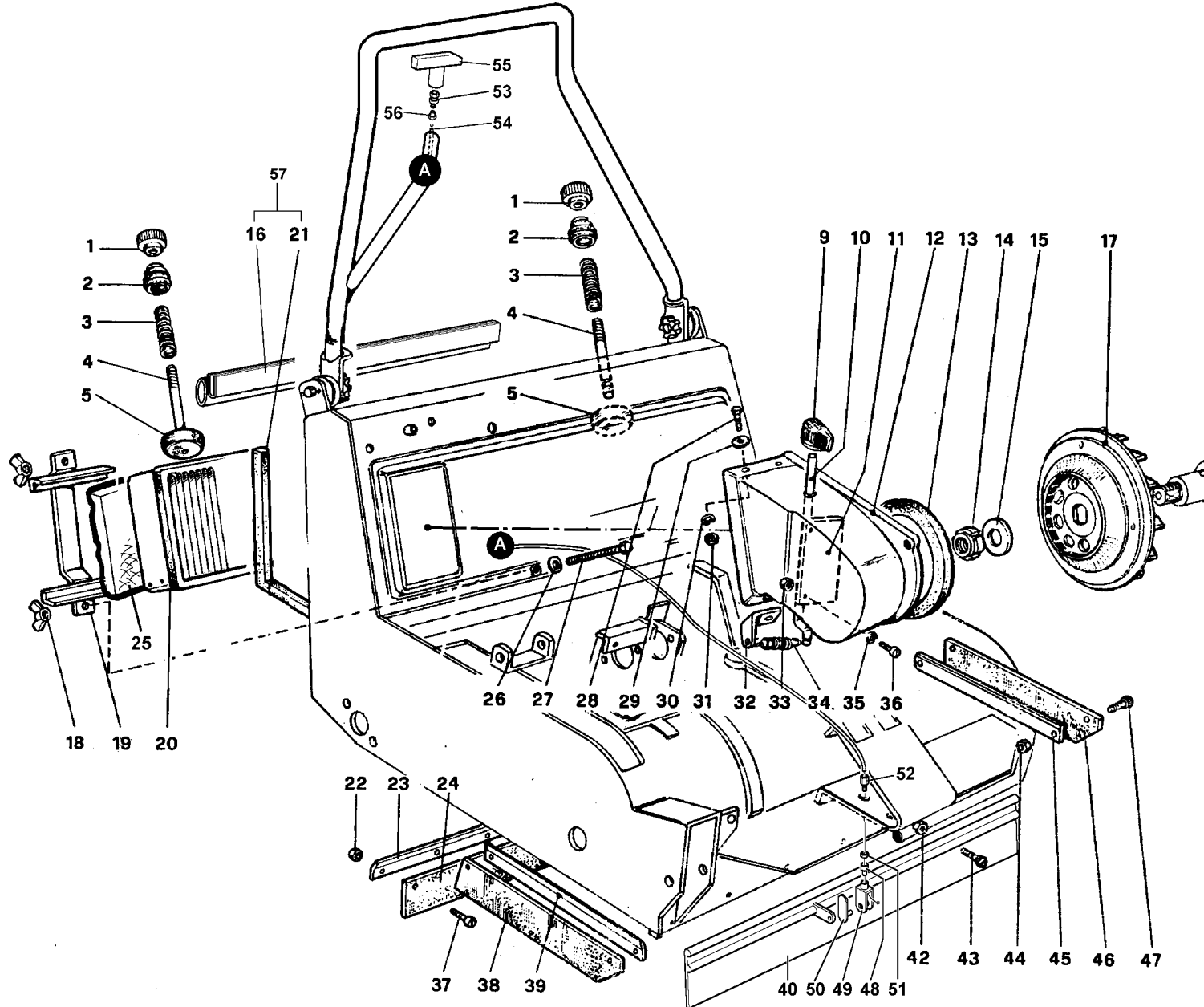

Item n°	Part n°	Quantity	Description	Descripción	Description	Benennung	Descrizione	Remarks
Bezn°	Código n°	Cantidad						Notas
N° pièce	Code n°	Quantité						Notes
Stück Nr.	Code Nr.	Anzahl						Bemerkungen
Part. n°	Codice n°	Quantità						Note
40	6295981	1	front rubber section	alerón anterior	profil en caoutchouc avant	vorderes Gummiprofil	flap anteriore	
41	6297061	1	rubber section securing strip	placa de parada goma	bande de fixation du profil en caoutchouc	Leiste Befestigung Gummiprofil	piastrino ferma gomma	
42	6295091	6	nut M5	tuerca M5	écrou M5	Mutter M5	dado M5	
43	6295081	6	allen-head screw M5x12	tomillo T.C. M5x12	vis à tête cylindrique M5x12	Zylinderkopfschraube M5x12	vite T.C. M5x12	
44	6295091	2+2	nut M5	tuerca M5	écrou M5	Mutter M5	dado M5	
45	6296971	1	rubber section securing strip	placa de parada goma	bande de fixation du profil en caoutchouc	Leiste Befestigung Gummiprofil	piastrino ferma gomma	
46	6295861	1	side rubber section	goma lateral	profil en caoutchouc latéral	seitliches Gummiprofil	gomma laterale	
47	6295081	2+2	allen-head screw M5x12	tomillo T.C. M5x12	vis à tête cylindrique M5x12	Zylinderkopfschraube M5x12	vite T.C. M5x12	
48	6296271	1	pin	tornillo	pivot	Bolzen	perno	
49	6296261	1	fork	horquilla	fourche	gabel	forcella	
50	6297141	1	clamp	parado	arrêt	Sicherung	fermo	
51	6295011	1	nut M6	tuerca M6	écrou M6	Mutter M6	dado M6	
52	6295661	1	adjuster	registro	reglage	Regler	registro	
53	6295741	1	adjuster	registro	reglage	Regler	registro	
54	6296361	1	flexible cable	cable flexible	câble flexible	Bowdenkabel	cavo flessibile	
55	6296471	1	handle	manilla T	poignée	Handgriff	maniglia T	
56	6297161	1	screw	tornillo perforada	vis	schraube	vite forata	
57	6295941	1	hopper gasket kit	kit profil de goma	ens.profil en caotchouc	Kit Gummiprofil	kit profili in gomma	
20	6296491	1	paper panel filter with prefilter	filtro de brocha con pre-filtro	filtre en panneau avec pré-filtre	Flachfilter mit Vorfilter	filtro a pannello con velcro	
20	6296521	1	polyester panel filter 20µ	filtro de brocha en poliésterin poliesterre 20µ	filtre en panneau en polyester 20µ	Flachfilter aus Polyester 20µ	filtro a pannello in poliesterre 20µ	optional



Sidewinder BP30

Table
Tabla
Table
Tafel
Tavola



Sidewinder BP30

Electric motor and controls
Motor eléctrico y mandos
Moteur électrique et commandes
Elektromotor und Steuerelemente
Motore elettrico e comandi

Table
Tabla
Table
Tafel
Tavola

6

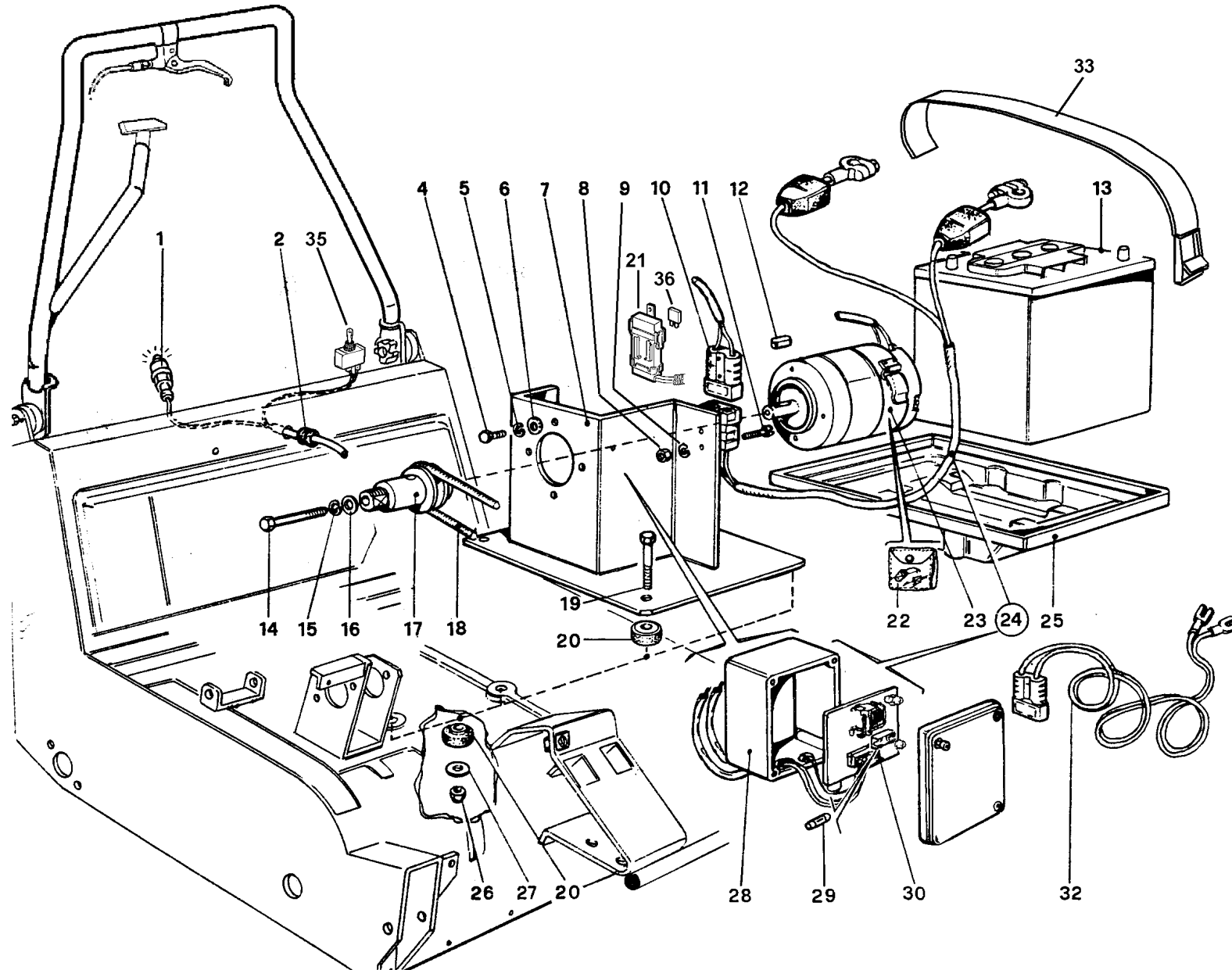

Item n°	Part n°	Quantity	Description	Descripción	Description	Benennung	Descrizione	Remarks
Pieza n°	Código n°	Cantidad						Notas
N° pièce	Code n°	Quantité						Notes
Stück Nr.	Code Nr.	Anzahl						Bemerkungen
Part. n°	Codice n°	Quantità						Note
1	6296021	1	battery charger indicator 12V	luz carga de batería 12 V	témoin charge batterie 12V	Ladestromkontrolleuchte 12V	spia carica batteria 12 V	
2	6295771	1	cable guide	anillo guía hilo	bague de guidage fil	Kabeldurchgang	anello passafilo	
3								
4	6295071	4	hexagonal head screw M6x16	tornillo T.E. M6x16	vis à tête à six pans M6x16	Sechskantschraube M6x16	vite T.E. M6x16	
5	6295111	4	spring washer ø 6	roseta ø 6	rondelle ø 6	Federscheibe ø 6	rosetta ø 6	
6	6295041	4	washer ø 6x13x1.5	arandela ø 6x13x1,5	rondelle ø 6x13x1,5	Scheibe ø 6x13x1,5	rondella ø 6x13x1,5	
7	6297251	1	motor support	soporte motor	support moteur	Motorhalterung	supporto motore	
8	6295261	2	nut M4	tuerca M4	écrou M4	Mutter M4	dado M4	
9	6295271	2	spring washer ø 4	roseta ø 4	rondelle ø 4	Federscheibe ø 4	rosetta ø 4	
10	6297401	2	plug	chaveta	fiche	Stecker	spina	
11		2	allen-head screw M4x20	tornillo T.C. M4x20	vis à tête cylindrique M4x20	Zylinderkopfschraube M4x20	vite T.C. M4x20	
12	6295461	1	key 5x5x20	lengueta 5x5x20	languette 5x5x20	Federkeil 5x5x20	linguetta 5x5x20	
13	6296101	1	battery 12V	batería 12V	batterie 12V	Batterie 12V	batteria 12V	
14	6295651	1	hexagonal head screw M6x70	tornillo T.E. M6x70	vis à tête à six pans M6x70	Sechskantschraube M6x70	vite T.E. M6x70	
15	6295111	1	spring washer ø 6	roseta ø 6	rondelle ø 6	Federscheibe ø 6	rosetta ø 6	
16	6295041	1	washer ø 6	arandela ø 6	rondelle ø 6	Scheibe ø 6	rondella ø 6	
17	6297151	1	pulley	polea	poulie	Riemenscheibe	puleggia	
18	6295871	1	belt ø 10 x L 600	correa ø 10 x L 600	courroie ø 10 x L. 600	Riemen ø 10 x L. 600	cinghia ø 10 x L 600	
19	6295161	4	hexagonal head screw M8x40	tornillo T.E. M8x40	vis à tête à six pans M8x40	Sechskantschraube M8x40	vite T.E. M8x40	
20	6295851	8	shock absorber	anillo amortiguador	amortisseur	Stoßdämpfer	anello ammortizzatore	
21	6297351	1	fuse box	caja de fusible	support de fusible	Sicherunghalter	portafusibile	
22	6296091	1	set of carbon brushes	serie carboncillo	jeu de balais	Kohlebürstensatz	serie carboncini	
23	6296151	1	electric motor 12V - 400W	motor eléctrico 12V - 400W	moteur électrique 12V-400W	Elektromotor 12V - 400W	motore elettrico 12V - 400W	
24	6296201	1	electric system assembly	conjunto instalación eléctrica	ensemble installation élect.	elektrische Anlage, komplett	assieme impianto elettrico	
25	6296541	1	battery housing	cubeta baterías	logement batteries	Batteriehalterung	vaschetta batterie	
26	6295351	4	self-locking nut M8	tuerca de seguridad M8	écrou de sûreté M8	Sperrnut M8	dado autobl. M8	
27	6295141	4	washer ø 8x24x2	arandela ø 8x24x2	rondelle ø 8x24x2	Scheibe ø 8x24x2	rondella ø 8x24x2	
28	6296171	1	box and cover	caja	boîtier	Dose	scatola	
29	6296041	1	fuse 2A - 250V	fusible 2A - 250V	fusible 2A - 250V	Sicherung 2A - 250V	fusibile 2A - 250V	
30	6296191	1	complete electric board	placa eléctrica completa	carte électrique complète	elektrische Karte, komplett	scheda elettrica completa	
31								
32	6297401	1	plug and cable	chaveta con cable	fiche avec câble	Stecker mit Kabel	spina con cavo	
33	6297301	1	belt	Correa	courroie	Gurt	cintura	
34								
35	6291541	1	toggle switch	interruptor	interrupteur	Schalter	interruttore	
36	6297361	1	fuse 50A	fusible 50A	fusible 50A	Sicherung 50A	fusibile 50A	



Sidewinder BP30

Table
Tabla
Tafel
Tavola

6

SIDEWINDER

SIDEWINDER

NSS ® Enterprises, Inc.

3115 Frenchmens Road, Toledo, Ohio 43607

PHONE (419) 531-2121 FAX (419) 531-3761

NSS ® Enterprises, Inc. European Distribution Centre

Unit II, Pinfold Trading Estate * 55 Nottingham Road
STAPLEFORD, NOTTINGHAM NG9 8AD ENGLAND U.K.

PHONE: (44) 0115 939 1568 * FAX: (44) 0115 949 0615