

DOMINATOR™

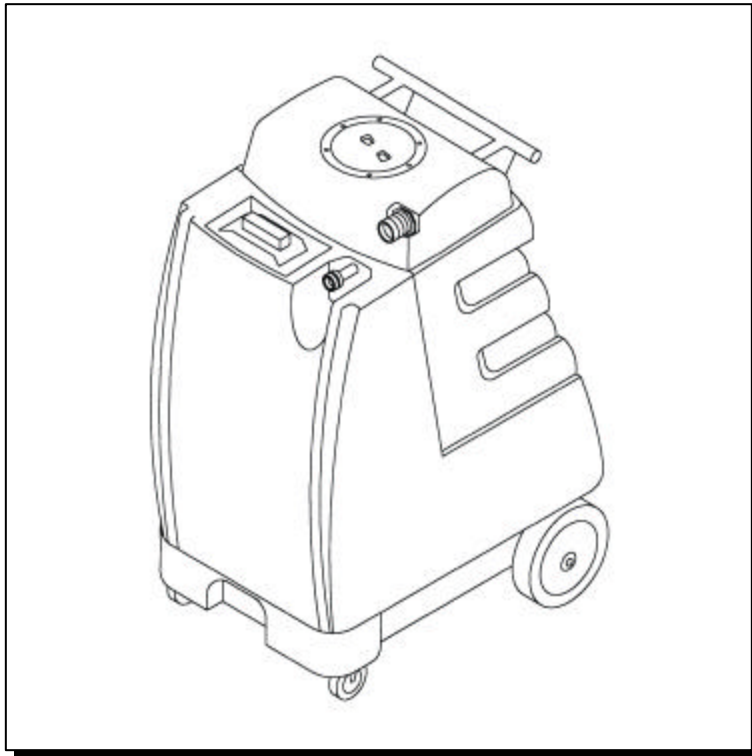

CARPET EXTRACTOR



Operating Instructions (ENG)

MODEL: D100

QUEST® ... for Continuous Improvement.
Windsor's Quality Management System is Certified ISO 9001.

Read these instructions before operating the machine

R

MACHINE DATA LOG

MODEL _____

DATE OF PURCHASE _____

SERIAL NUMBER _____

SALES REPRESENTATIVE # _____

DEALER NAME _____

OPERATIONS GUIDE NUMBER _____

PUBLISHED _____

YOUR DEALER

Name: _____

Address: _____

Phone Number: _____

TABLE OF CONTENTS

<i>Machine Data Log</i>	2
<i>Table of Contents</i>	3

HOW TO USE THIS MANUAL

<i>How to use this Manual</i>	1-1
-------------------------------------	-----

SAFETY

<i>Important Safety Instructions</i>	2-1
<i>Hazard Intensity Level</i>	2-2
<i>Grounding Instructions</i>	2-3

OPERATIONS

<i>Technical Specifications</i>	3-1
<i>Carpet Inspection</i>	3-2
<i>Accessories</i>	3-2
<i>General Information</i>	3-2
<i>Equipment Set-Up</i>	3-2

MAINTENANCE

<i>Daily Maintenance</i>	4-1
<i>Periodic Maintenance</i>	4-1
<i>Vacuum Motor Replacement</i>	4-2
<i>Pump Replacement</i>	4-3
<i>Machine Troubleshooting</i>	4-4
<i>Wiring Diagram</i>	4-5
<i>Service Schedule</i>	4-6

GROUP PARTS LIST

<i>Recovery Tank Assembly</i>	5-1
<i>Solution Tank Assembly</i>	5-3
<i>Suggested Spare Parts</i>	5-5
<i>Warranty</i>	5-6

HOW TO USE THIS MANUAL

This manual contains the following sections:

- HOW TO USE THIS MANUAL
- SAFETY
- OPERATIONS
- MAINTENANCE
- PARTS LIST

The HOW TO USE THIS MANUAL section will tell you how to find important information for ordering correct repair parts.

Parts may be ordered from authorized Windsor dealers. When placing an order for parts, the machine model and machine serial number are important. Refer to the MACHINE DATA box which is filled out during the installation of your machine. The MACHINE DATA box is located on the inside of the front cover of this manual.

MODEL _____
DATE OF PURCHASE _____
SERIAL NUMBER _____
SALES REPRESENTATIVE # _____
DEALER NAME _____
OPERATIONS GUIDE NUMBER _____
PUBLISHED _____

The model and serial number of your machine is on the bottom back-end of the machine.

The SAFETY section contains important information regarding hazard or unsafe practices of the machine. Levels of hazards is identified that could result in product or personal injury, or severe injury resulting in death.

The OPERATIONS section is to familiarize the operator with the operation and function of the machine.

The MAINTENANCE section contains preventive maintenance to keep the machine and its components in good working condition. They are listed in this general order:

- Daily Maintenance
- Periodic Maintenance
- Vacuum Motor Replacement
- Pump Replacement
- Machine Troubleshooting
- Service Schedule

The PARTS LIST section contains assembled parts illustrations and corresponding parts list. The parts lists include a number of columns of information:

- **REF** – column refers to the reference number on the parts illustration.
- **PART NO.** – column lists the part number for the part.
- **QTY** – column lists the quantity of the part used in that area of the machine.
- **DESCRIPTION** – column is a brief description of the part.
- **SERIAL NO. FROM** – column indicates the first machine the part number is applicable to. When the machine design has changed, this column will indicate serial number of applicable machine. The main illustration shows the most current design of the machine. The boxed illustrations show older designs. If column has an asterisk (*), call manufacturer for serial number.
- **NOTES** – column for information not noted by the other columns.

NOTE: If a service or option kit is installed on your machine, be sure to keep the KIT INSTRUCTIONS which came with the kit. It contains replacement parts numbers needed for ordering future parts.

NOTE: The 98# on the lower left corner of the front cover is the part number for this manual.

SAFETY INSTRUCTIONS

IMPORTANT SAFETY INSTRUCTIONS

When using an electrical appliance, basic precaution must always be followed, including the following:

READ ALL INSTRUCTIONS BEFORE USING THIS MACHINE.

This machine is for commercial use.



To reduce the risk of fire, electric shock, or injury:

Connect to a **properly grounded outlet**. See Grounding Instructions.

Do not leave the machine unattended. Unplug machine from outlet when not in use and before maintenance or service.

Use only indoors. Do not use outdoors or expose to rain.

Do not allow machine to be used as a toy. **Close attention** is necessary when used by or near children.

Use only as described in this manual. Use only manufacturer's recommended components and attachments.

Do not use damaged electrical cord or plug. Follow all instructions in this manual concerning grounding the machine. If the machine is **not working properly**, has been dropped, damaged, left outdoors, or dropped into water, return it to an authorized service center.

Do not pull or carry machine by electrical cord, use as a handle, close a door on cord, or pull cord around sharp edges or corners.

Do not run machine over cord. **Keep** cord away from heated surfaces.

Do not unplug machine by pulling on cord. To unplug, grasp the electrical plug, not the electrical cord.

Do not handle the electrical plug or machine with wet hands.

Do not operate the machine with any openings blocked. Keep openings free of debris that may reduce airflow.

This machine is intended for cleaning carpet only.

Do not vacuum anything that is burning or smoking, such as cigarettes, matches, or hot ashes.

This machine is not suitable for picking up health endangering dust.

Turn off all controls before unplugging.

Machine can cause a fire when operating near flammable vapors or materials. Do not operate this machine near flammable fluids, dust or vapors.

This machine is suitable for commercial use, for example in hotels, schools, hospitals, factories, shops and offices for more than normal housekeeping purposes.

Maintenance and repairs must be done by qualified personnel.

If foam or liquid comes out of machine, switch off immediately.

SAVE THESE INSTRUCTIONS

HAZARD INTENSITY LEVEL

The following symbols are used throughout this guide as indicated in their descriptions:

HAZARD INTENSITY LEVEL

There are three levels of hazard intensity identified by signal words -**WARNING** and **CAUTION** and **FOR SAFETY**. The level of hazard intensity is determined by the following definitions:

! WARNING

WARNING - Hazards or unsafe practices which COULD result in severe personal injury or death.

! CAUTION

CAUTION - Hazards or unsafe practices which could result in minor personal injury or product or property damage.

FOR SAFETY: To identify actions which must be followed for safe operation of equipment.

Report machine damage or faulty operation immediately. Do not use the machine if it is not in proper operating condition. Following is information that signals some potentially dangerous conditions to the operator or the equipment. Read this information carefully. Know when these conditions can exist. Locate all safety devices on the machine. Please take the necessary steps to train the machine operating personnel.

FOR SAFETY:

DO NOT OPERATE MACHINE:

Unless Trained and Authorized.

Unless Operation Guide is Read and understood.

In Flammable or Explosive areas.

In areas with possible falling objects.

WHEN SERVICING MACHINE:

Avoid moving parts. Do not wear loose clothing; jackets, shirts, or sleeves when working on the machine. Use Windsor approved replacement parts.

GROUNDING INSTRUCTIONS

THIS PRODUCT IS FOR COMMERCIAL USE ONLY.

ELECTRICAL:

In the USA this machine operates on a standard 15 amp 115V, 60 hz, A.C. power circuit . The amp, hertz, and voltage are listed on the data label found on each machine. Using voltages above or below those indicated on the data label will cause serious damage to the motors.

GROUNDING INSTRUCTIONS:

This appliance must be grounded. If it should malfunction or break down, grounding provides a path of least resistance for electric current to reduce the risk of electric shock. This appliance is equipped with a cord having an equipment-grounding conductor and grounding plug. The plug must be inserted into an appropriate outlet that is properly installed and grounded in accordance with all local codes and ordinances. This appliance is for use on a nominal 115-volt circuit, and has a grounded plug that looks like the plug in "Fig. A". A temporary adaptor that looks like the adaptor in "Fig . C" may be used to connect this plug to a 2-pole receptacle as shown in "Fig. B", if a properly grounded outlet is not available. The temporary adaptor should be used only until a properly grounded outlet (Fig. A) can be installed by a qualified electrician. The green colored rigid ear, lug, or the like extending from the adaptor must be connected to a permanent ground such as a properly grounded outlet box cover. Whenever the adaptor is used, it must be held in place by a metal screw.

⚠ WARNING:

Improper connection of the equipment-grounding conductor can result in a risk of electric shock. Check with a qualified electrician or service person if you are in doubt as to whether the outlet is properly grounded. Do not modify the plug provided with the appliance - if it will not fit the outlet, have a proper outlet installed by a qualified electrician.

PROPER GROUNDING

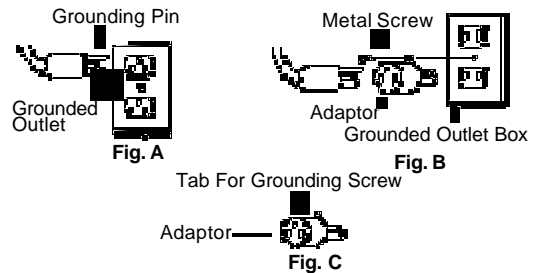

NOTE: In Canada, the use of a temporary adaptor is not permitted by the Canadian Electrical Code

CHEMICALS

Suitable Chemicals

*Alkalis
Detergents
Hydroxides
Soaps
Vinegar*

Non-Compatible

*Aldehydes
Aromatics Hydrocarbons
SP Butyls
Carbon Tetrachloride
Clorox*
Chlorinated Bleaches
Chlorinated Hydrocarbons
Lysol*
Methyl Ethel Ketone (MEK)
Perchorethylene (perc)
Phenolics
Trichlorethylene
D-Limonene*

Warning:

Using the incompatible chemicals listed above will damage the machine. Damages of this type are not covered under the warranty. Carefully read ingredients on manufacturer's label before using any product in this machine.

TECHNICAL SPECIFICATIONS

ITEM	DIMENSION/CAPACITY
Electrical	115V, 60Hz, 15A
Electric Vacuum Motor	2HP, 3 Stage
Waterlift	137" (348 cm)
Solution Pump	100 psi
Solution Capacity	17 gallons (64.3 l)
Recovery Capacity	15 gallons (56.75 l)
Dimensions - Weight	69 lbs. (31.4 kg)
Dimensions – Length	20" (50.80 cm)
Dimensions - Height	36" (91.44 cm)
Dimensions - Width	16" (40.64 cm)
Power Cable	2-25' (6.35m)

OPERATIONS

CARPET INSPECTION:

Determine precisely what areas you are going to clean. Note problem areas in the carpet or tack strip. Look for loose carpet, heavily damaged areas, discolored stains, or grease spots that will require prespotting. Note the carpet type. Check the availability of hot water, drains, and suitable electrical outlets. If the carpet is loose or worn, have it repaired **before** attempting to clean it.

Plan the cleaning route, work from the most remote area towards the exit. Try not to travel over the cleaned areas when getting fresh water or dumping old. Furniture should be moved out away from the walls before cleaning. If furniture is moved back in place before carpet is completely dry, place plastic or foil protectors under the legs to prevent possible carpet staining. When possible use a Windblower (WB3) and open all windows and doors to speed carpet drying.

ACCESSORIES:

The D100 can be used with the following Windsor equipment: Deluxe Hand Tool (DHT), Pile Jogger(PJ2A), Standard Floor Wands(SFW, SW, SW-PRO, PROW), & Wind Blower carpet dryer(WB3). Contact an authorized Windsor dealer for assistance in choosing the right equipment .

GENERAL INFORMATION:

On heavily soiled carpets, or on areas of high foot traffic, it may be necessary to use a prespray or traffic lane cleaner applied with a Pro-Spray. Do not add presprays to the machine's solution tank. If a spotter is used, follow the manufacturer's instructions exactly as printed on the label. Remove the spotter with the floor tool when done, spotter left in the carpet may bleach or brown it permanently.

As the carpet is being cleaned, check to see if there is foam building up in the recovery bucket. Add a little defoaming compound to the recovery tank but never to the solution tank.

For infrequent use or long periods of storage, flush the system with a neutralizing solution of 1 quart white vinegar mixed with 2 gallons hot water. Flush the system with clean hot water after neutralizing.

For hose fitting lubrication, use a light silicone lubricant which will not damage o-rings.

PROTECT THIS MACHINE FROM FREEZING.

EQUIPMENT SET-UP:

- 1.) Plug power cable from machine into properly grounded wall outlet.
- 2.) Turn vacuum motor switch on and off to make sure there is electrical power at machine.
- 3.) Connect vac hose to machine. Slide the swivel cuff over the outlet on the tank.
- 4.) Connect the hose set to your machine and wand. Pull back the knurled collar on the quick disconnect coupler and push onto the connection on the chassis. To avoid leaks, check to be sure a positive connection was made.
- 5.) Using a clean container, fill the solution tank with clean, hot water. Mix in a non-foaming cleaning concentrate for use in hot water extraction machines following the manufacturer's instructions, as printed on the container. **When using a powder cleaner, premix with hot water in a clean container before adding to the solution tank.**
- 6.) Turn pump and vacuum switch to the on position.
- 7.) Start cleaning.

MAINTENANCE

DAILY MAINTENANCE:

(At the end of each working day) :

- 1.) Flush the entire system, including floor tool, hand tool, etc., with 1 to 3 gallons of clean, hot water.
- 2.) Vacuum out the solution tank .
- 3.) Rinse tank with fresh water. Periodically inspect the recovery tank and decontaminate if necessary, using a Hospital Grade Virucide or a 1-10 bleach to water solution. Waste water should be disposed of properly.
- 4.) Remove lint build-up from the float shut-off screen in the recovery tank . (Occasionally check filter screen at the bottom of the solution tank and rinse clean with hot water if necessary).
- 5.) Inspect hoses for wear. Frayed or cracked hoses should be replaced to avoid vacuum or solution pressure loss.
- 6.) Inspect power cord for wear or damage. This cable will lay on wet carpet. To prevent electrical shock replace cords that are frayed or have cracked insulation immediately.
- 7.) Ensure automatic shut-off ball is working properly.
- 8.) Clean all dirt and obstructions from drain valve and gaskets to prevent possible leakage and premature wear.
- 9.) Run clean water through solution pump when work is complete.
- 10.) Empty both tanks and rinse, run vacuum (s) for at least one minute to dry motor(s).
- 11.) Store with access covers removed to allow tanks to dry.

PERIODIC MAINTENANCE

- 1.) Twice a month, flush a white vinegar solution (One quart vinegar to two gallons of water) or anti-browning solution (mixed as directed) through the extractor, turning pump switch on/off several times, flush with clean water. This will prevent build-up of alkaline residue in the system.
- 2.) Check hoses for wear, blockages, or damage. Frayed or cracked hoses should be repaired or replaced to eliminate vacuum or solution pressure loss.
- 3.) Check all handles, switches, knobs, electrical cables and connections on your machine for damage. If the cable insulation is broken or frayed, repair or replace it immediately. Don't take chances with electrical fire or shock.
- 4.) Clean out solution tank and remove and clean solution screen.
- 5.) Clean outside of all tanks and check for damage.

Monthly Maintenance

- 1.) Check all bearings for noise and wear.
- 2.) Check all gaskets for wear and leakage.
- 3.) Check pump pressure; observe spray pattern and check with gauge if necessary.
- 4.) Check overall performance of machine.

SEMI-ANNUALLY

- 1.) Check vacuum motor brushes.



WARNING

ONLY QUALIFIED MAINTENANCE PERSONNEL ARE TO PERFORM THE FOLLOWING REPAIRS.

VACUUM MOTOR REPLACEMENT

1. Turn off all switches and unplug machine.
2. Remove recovery tank.
3. Locate the vacuum motor wires and disconnect at the connector.
4. Remove the vacuum motor.
5. Reverse process to install vacuum motor.

Vac Motor Carbon Brushes Replacement

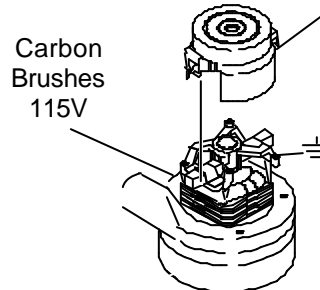

WARNING: The green ground wire must be attached for safe operation. See wiring diagram.

Note: When replacing carbon vac motor brushes loosen wire terminal **BEFORE** removing screws on bracket.

If armature commutator is not concentric, extremely pitted, or grooved the motor will need to be replaced or sent to a qualified service center to restore vac performance.

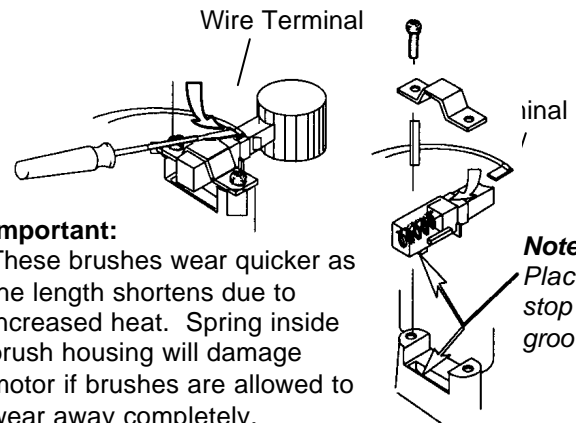

Important: These brushes wear quicker as the length shortens due to increased heat. Spring inside brush housing will damage motor if brushes are allowed to wear away completely.

Note: Place stop in groove.

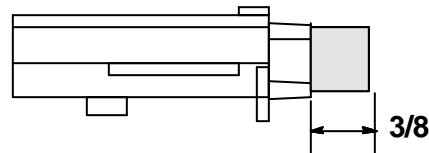

Periodically check the length of the carbon brushes. Replace both carbon brushes when either is less than 3/8" long.

MAINTENANCE



WARNING:

ONLY QUALIFIED MAINTENANCE PERSONNEL ARE TO PERFORM THE FOLLOWING REPAIRS.

PUMP REPLACEMENT PARTS FOR FLOJET 100 PSI (65219)

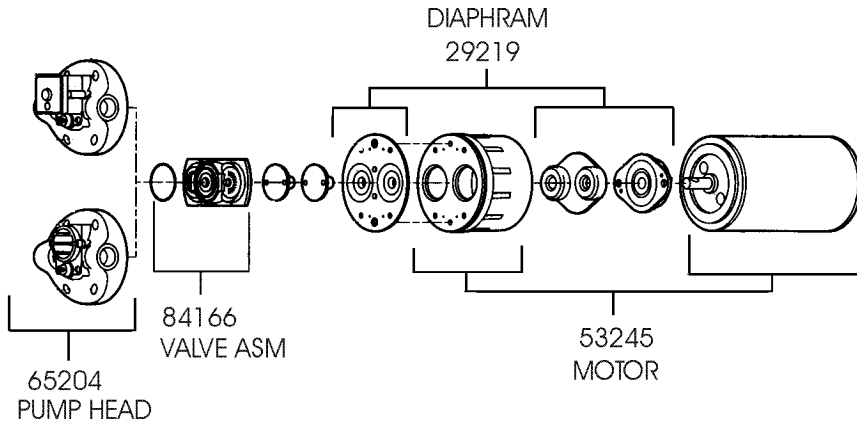

SOLUTION PUMP REPLACEMENT

1. Turn off all switches and unplug the machine.
2. Remove recovery tank.
3. Remove solution hoses from fittings in pump.
4. Remove the (2) screws that fasten the pump to the frame.
5. Reverse process to install pump.

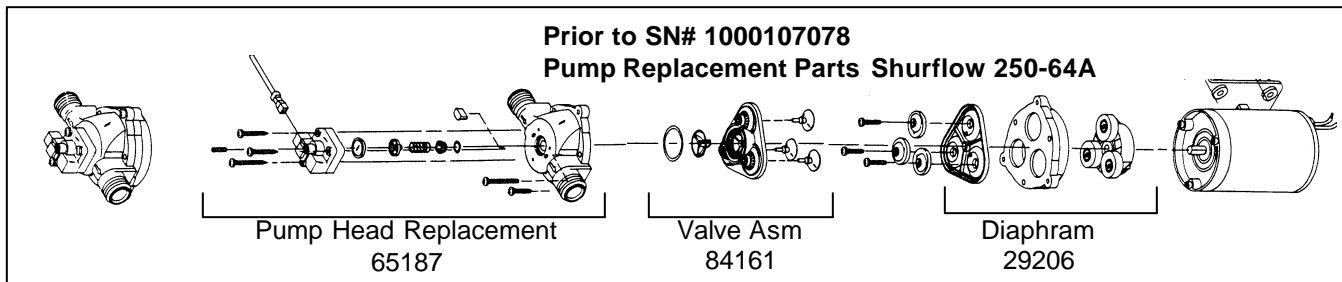

TROUBLESHOOTING

PROBLEM.	CAUSE	SOLUTION
No power to machine.	Faulty power cord.	Replace.
	Dead electrical circuit.	Check building circuit breaker or fuse box.
Electrical shock.	Equipment not grounding.	Follow grounding instructions exactly.
	Receptacle not grounded.	Contact an electrician to check building's wiring.
Vac motor speed varies or doesn't run.	Internal wiring problem.	Have a trained service technician check machine's wiring.
	Worn motor brushes.	Replace.
	Motor worn out.	Replace.
Loss of vacuum.	Faulty switch.	Replace.
	Loose vacuum dome.	Center and seal dome over tank.
	Crack in dome or poor joint.	Replace or repair using acrylic plastic cement only.
	Lint or dirt clogging vacuum screen.	With power off, clean screen.
	Loose cuffs on vacuum hose.	Tighten cuffs turning counterclockwise.
	Vac motor seals leaking.	Replace.
	Floor tool vac chamber clogged.	Wash out with hose. Pick lint out with a wire.
	Vac motor, hose or gasket.	Replace.
Solution hose fitting hard to connect.	Corrosion on fittings.	Clean with steel wool. Soak in acetic acid (white vinegar). Lubricate lightly with silicone base lubricant.
Carpet not getting clean.	Severe soil conditions.	Make several passes at right angles to each other. Use a prespray.
Carpet too wet.	Over saturation.	Adjust solution pressure to lower settings. Make several passes with spray.
Carpet browning.	Leaving carpet too wet.	Check for loss of vac pressure.
	Too much chemical in.	Check label for correct solution concentration.
Solution not flowing properly.	Light carpet with no brown prevention.	Go over carpet with browning prevent only.
	Solution hose connection.	Check for positive connection.
	Faulty pump.	Repair or replace.
	Faulty floor tool valve.	Repair or replace.
	Faulty pump switch.	Repair.

SERVICE SCHEDULE

MAINTENANCE	DAILY	WEEKLY	QUARTERLY
Check machine for cord damage	*		
Check recovery dome and gasket for damage and cleanliness	*		
Check hoses for wear, blockages, or damage	*		
Check handles, switches, and knobs for damage	*		
Check vac motor intake filter and clean	*		
Run one gallon of water through system	*		
Clean out recovery tank and check float valve to make sure it moves freely	*		
Clean out solution tank and remove and clean vacuum intake screen	*		
Clean outside of all tanks and check for damage	*		
Run vac motor for at least one minute to allow motor to dry	*		
Store with dome off tank to allow the tank to dry	*		
Check all gaskets for wear and leakage		*	
Check vacuum intake screen for damage; replace if necessary		*	
Check pump pressure; observe spray pattern and check with gauge if necessary		*	
Check and clean solution screen		*	
Check cables for fraying		*	
Check overall performance of machine		*	
Check vac motor carbon brushes			*

RECOVERY TANK ASSEMBLY

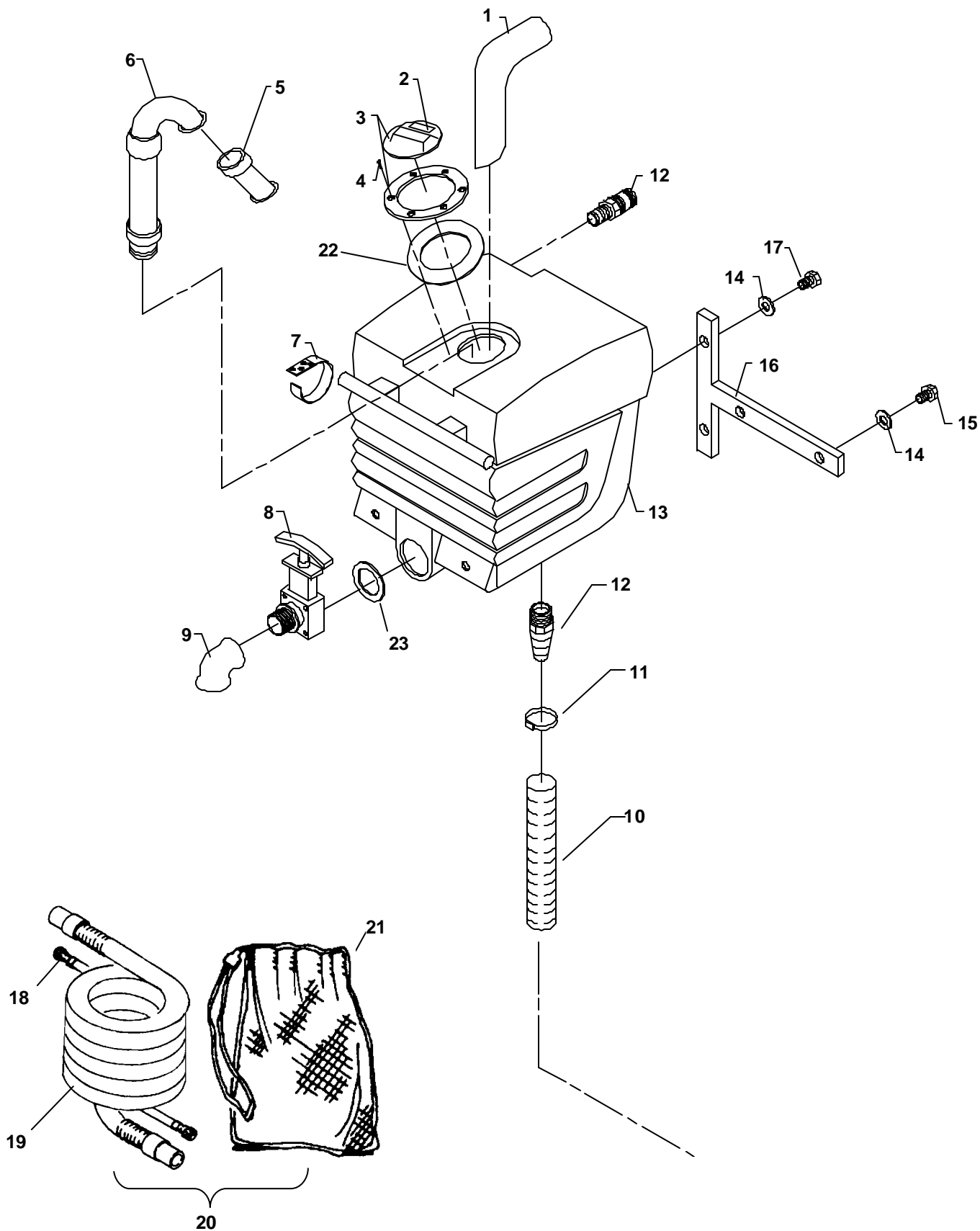

RECOVERY TANK ASSEMBLY

REF	PART NO.	QTY	DESCRIPTION	SERIAL NO. FROM	NOTES:
1	05151	1	TUBE ASM, RECOVERY TANK		
2	500009	1	LABEL, WARNING		
3	260-64A	1	ACCESS COVER CLEAR 6" W/RIM		
4	70546	6	SCR, 8 X 3/4 PFHT/S BLK ZINC		
5	090-12A	1	FLOAT CAGE ASSY COMPLETE SLIP		
6	78475	1	VAC STACK ASM, 17 GAL PORTABLES		
7	320-05	1	VELCRO STRAPS		
8	15-808123	1	DUMP VALVE 2"		
9	11-800444	1	ELBOW, 1.5 2" 45D PVC SCH40		
10	39276	1	HOSE, 1.5 BLK VAC X 14"		
11	20063	1	CLAMP, 1.75" WORM GEAR X .312		
12	40001R	2	HOSEBARB, 1.5MPT X 1.5		
13	75358	1	TANK, RECOVERY DOM 100		
14	87013	4	WASHER, 1/4 ID X 5/8 OD SS		
15	70015	2	SCR, 1/4-20 X 3/4 HHCS SS DL		
16	065-25	1	TANK BRACE ASM, D/B		
17	70020	2	SCR, 1/4-20 X 1/2 HHCS SS NP		
18	39573	1	HOSE ASM, 3/8 LP SLTN 16.5 FT		
19	150-44A	1	VAC HOSE 16-1/2' W/CUFFS 1-1/2		
20	47357	1	KIT, HOSE ASM W/BAG DOM100		
21	150-65	1	HOSE BAG 24" X 36"		
22	35255	1	GASKET, TANK LID		
23	35256	2	GASKET, DUMP VALVE		

SOLUTION TANK ASSEMBLY

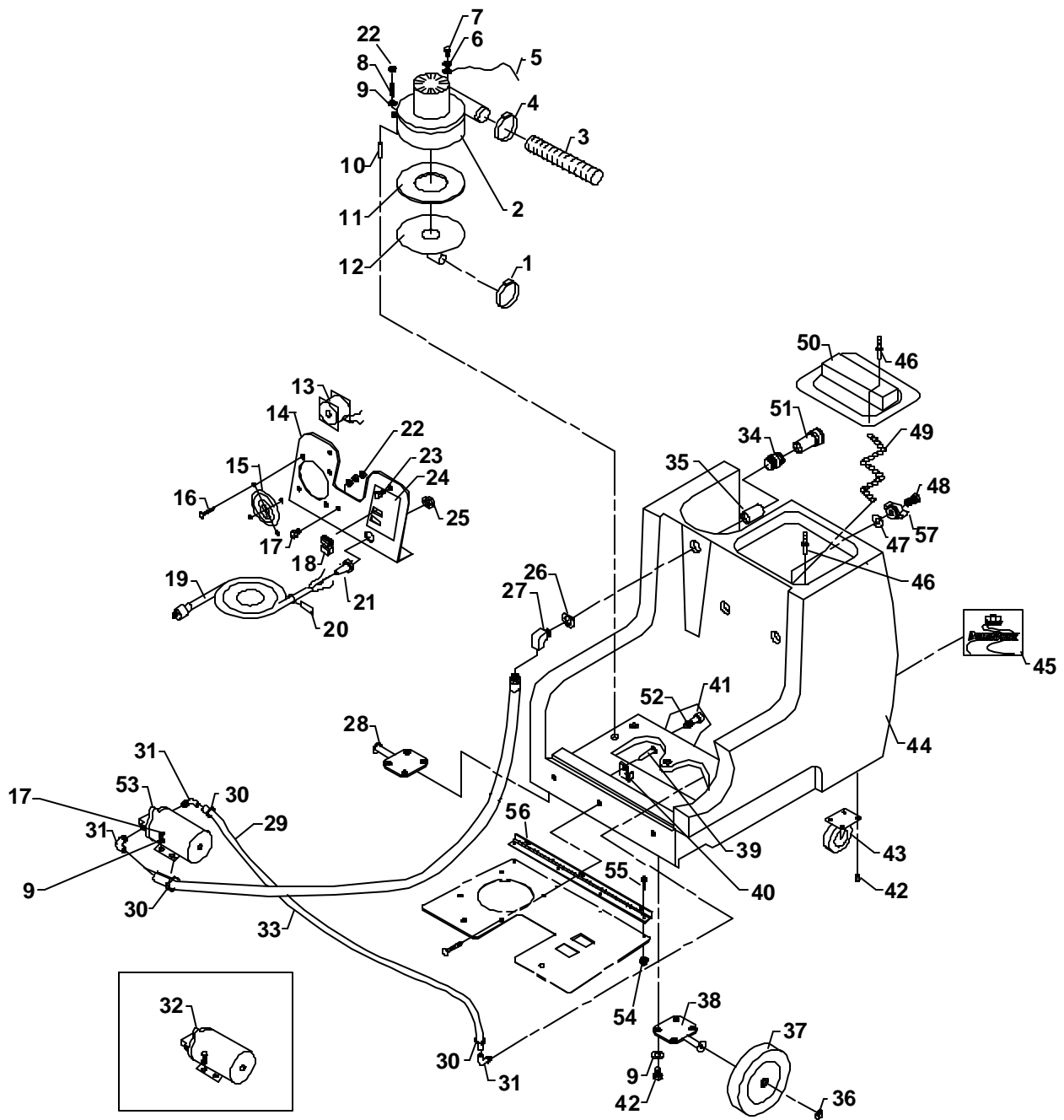

SOLUTION TANK ASSEMBLY

REF	PART NO.	QTY	DESCRIPTION	SERIAL NO. FROM	NOTES:
1	20063	1	CLAMP, 1.75" WORM GEAR X .312		
2	85049	1	VAC MTR ASM, D/B SLTN 115V 3ST		
3	39582	1	HOSE, VAC EXHAUST X 9"		
4	20046	1	CLAMP, 2.25" WORM GEAR		
5	880292	1	WIRE, 4" GRN/14 76010 X 76014		
6	87016	1	WASHER, #10 LOCK EXT STAR SS		
7	70335	1	SCR, 10-32 X 1/2 PHTR GRN/GRND		
8	70814	3	STUD, 1/4-20 X 4.5 SS		
9	87013	13	WASHER, 1/4 ID X 5/8 OD SS		
10	065-24E	3	VAC SPACER 3 1/8 III STAGE		
11	35166	1	GASKET, VAC MTR		
12	360-24A	1	PLATE ASM, VAC 90 DEG		
13	070-08	1	FAN 105 CFM AXIAL		
14	065-91A	1	ACCESS PANEL WINDSOR DOM SGL-V		
15	070-08A	1	FAN FINGER GUARD		
16	70626	4	SCR, #10 X 3/4 PPHST HI-LO BLK		
17	70018	3	SCR, 1/4-20 X 1 HHCS SS		
18	72142	2	SWITCH, SPST 15A EURO ROCKER		
19	060-04A	1	CORD 25' BLK 14/3 SJTW/A PLUG		
20	170-41	1	LABEL CIRCUIT INTERRUPTER		
21	73195	1	STRAIN RELIEF, 1/2 NPT (.48 ID)		
22	57105	6	NUT, 1/4-20 HEX W/ STAR WASHER		
23	140-11	1	KNOB RT/TANK		
24	170-43B	1	WINDSOR SWITCH LABEL		
25	57040	1	NUT, 1/2 NPT CONDUIT		
26	87217	1	WASHER, 9/16 ID MCHD		
27	030-16	1	ELBOW, 1/4 NPT STREET LONG 90D		
28	010-02	1	AXLE ASM, RIGHT		
29	39036	1	HOSE, 3/8 NYLOBRAID X 12"		
30	20042	3	CLAMP, 3/8 HOSE (D-SLOT)		
31	40043	3	HOSEBARB, 3/8MPT X 3/8 90D		
32	250-64A	1	SHURFLO 100PSI PUMP DEMAND		
33	151-48B	1	HOSE, 52.5 GRY 3/8 1/4 MPTXCUT		
34	56014	1	NIPPLE, 1/4 FPT QD		
35	22014	1	COUPLER, 1/4F HEX		
36	57196	2	NUT, 1/2 PUSH-ON DOME CAP		
37	040-06	2	WHEEL 8" BLK CENTERED HUB		
38	010-01	1	AXLE ASM, LEFT		
39	70232	4	SCR, 10-32 X 3/8 PPHMS SS		
40	20008	1	CLAMP, 5/8 NYLON UL/USA		
41	290-08	1	SOL SCREEN (ACORN) W/RUB BASE		
42	70020	16	SCR, 1/4-20 X 1/2 HHCS SS NP		
43	040-03	2	CASTER SWIVEL 4" SWIVEL		
44	75337	1	TANK, SOLUTION DOM 100 DK BLU		
45	500378	1	LABEL, DOMINATOR		
46	280-02	2	RIVIT AL. 3/16 X 1/2 CLOSED		
47	390-74	2	WASHER 1/4 X 5/8 BONDED NEOPRN		
48	70619	1	SCR, 1/4-20 X 2.0 HHMS SS F/T		
49	27912	1	CHAIN ASM, #10 BEAD S/S W/EVES		
50	260-71	1	SOLUTION COVER D/B		
51	56012	1	NIPPLE, 1/4 FPT QD		
52	250-15	1	HOSEBARB, 3/8 NPT X 3/8 H		
53	65219	1	PUMP, 115V 100PSI BYPASS W/SW	1000107078	
54	57187	4	NUT, 6-32 ACORN, ZINC		
55	70127	4	SCR, 6-32 X 1/4 PPHMS SS		
56	41393	1	HINGE, ACCESS PANEL		
57	48100	1	KNOB, HEX PRESS LOC WING		
58	57037	1	NUT, 1/4-20 WING SS		NOT SHOWN

SUGGESTED SPARE PARTS

PART NO.	DESCRIPTION	SERIAL NO. FROM	NOTES
140370	CARBON BRUSHES		
85049	VAC MOTOR ASM, 115 3ST D/B		
65215	PUMP ASM, 100 PSI		
330-02	ROCKER SWITCH		
040-06	8" GRAY RUBBER WHEEL		
57196	WHEEL CAP ½		
040-03	4" CASTER		
370-08	SEAL, DUMP VALVE		
140-11	SWITCH PLATE KNOB		
260-64A	ACCESS COVER		
290-08	STRAINER		
65204	KIT, PUMP HEAD REPLACEMENT		
84166	KIT, VALVE ASM PUMP		
29219	KIT, PUMP DIAPHRAGM		

NOTES:



WINDSOR INDUSTRIES

New Machine Warranty

Limited Warranty

Windsor Industries, Inc. warrants new machines against defects in material and workmanship under normal use and service to the original purchaser. Any statutory implied warranties, including any warranty of merchantability or fitness for a particular purpose, are expressly limited to the duration of this written warranty. Windsor will not be liable for any other damages, including but not limited to indirect or special consequential damages arising out of or in connection with the furnishing, performance, use or inability to use the machine. This remedy shall be the exclusive remedy of the buyer. The warranty period is subject to the conditions stated below.

6 / 3 / 1 Warranty: 6 Years Polyethylene (PE) Housings, 3 Years Parts, and 1 Year Service Labor

Subject to conditions outlined below, Windsor Industries warrants rotationally molded PE housings and parts on all of its machines to be free from defects in material and workmanship, under normal use and service for six (6) years to the original owner.

Under this warranty we guarantee the performance of non-polyethylene parts and components to be free from defects and for up to three (3) years to the original end user. Parts replaced or repaired under this warranty are guaranteed for the remainder of the original warranty period. (See table below)

Service labor charges are covered for up to one (1) year from the date of purchase through authorized Windsor service provider. No travel coverage is extended for cord-electric models. See table below for each general product model warranty coverage.

Product	PE Housing & Parts	Non- PE Parts	Service Labor	Travel
Rider Scrubbers	6 years	3 years	1 years	6 Months
Rider Sweepers	6 years	1 year	1 years	6 Months
Walk Behind Scrubbers	6 years	3 years	1 years	6 Months
Walk Behind Sweepers	6 years	1 year	1 years	6 Months
Extractors	6 years	3 years	1 years	-
Polishers / Elec. Burnishers / GH	6 years	3 years	1 years	-
Wide Areas Vacuums	6 years	3 years	1 years	-
VacPak Vacuums	6 years	1 year	1 year	-
Air Movers / Dri-matic / TITAN™	1 year	1 year	1 year	-
Propane Burnishers / Strippers	-	2 year	1 year	-
Tracer/Flex Sweepers/Scrubbers	6 years	2 year	6 months	90 days

VERSAMATIC®	Brush motor, Vacuum motor, Belts – 3 years	All other parts – 1 year
SENSOR®	Vacuum motor, Belts – 2 years	All other parts – 1 year

Product exceptions and Exclusions:

- Extractor brush motors, pump motors, **ALL** PC boards and electronics, **ALL** Vacuum motors (other than VERSAMATIC® and SENSOR®), **ALL** pumps, and FLEXSOL™ diaphragms carry a one (1) year parts and service labor warranty.
- The Onan® engines have three (3) year manufacturer’s warranty. The Honda® and Kawasaki® engines have two (2) year manufacturer’s warranty. **NOTE:** The engine warranty is administered through the engine manufacturer and must be repaired at an authorized service center.

Normal wear items and accessories including, but not limited to, belts, brushes, capacitors, carbon brushes, casters, clutches, cords, filters, finishes, gaskets, hoses, light bulbs, rectifiers, switches, squeegees, bearings, pulleys, relays, actuating cables, wheels, tires, propane tanks, and batteries will be warranted for manufacturing defects for 90-days from the purchase date.

The warranty commences on the purchase date by the original end user from an authorized Windsor agent, subject to proof of purchase. The Machine Registration Card must be completed and returned immediately at the time of purchase. If proof of purchase cannot be identified, the warranty start date is 90 days after the date of sale to an authorized Windsor distributor. Parts replaced or repaired under warranty are guaranteed for the remainder of the original warranty period.



WINDSOR INDUSTRIES New Machine Warranty

90 Day Warranty Extension Available

Upon receipt of the Machine Registration Card, Windsor will extend by 90 days, from the date of purchase, all items included under the one-year provision. This applies only to one-year items and does not include 90-day wear items.

This Warranty Shall Not Apply To:

1. Any product that has been subject to abuse, misuse, neglect or unauthorized alteration (including the use of incompatible or corrosive chemicals or overloading of capacity).
2. Products that have experienced shipping or freight damage.
3. Repairs necessary to correct any failure due to improper pre-delivery service and inspection by the selling dealer.
4. Excessive time for cleaning units in preparation for repair.
5. Any repairs resulting from poor initial service work or improper diagnosis.
6. Tune-up parts such as plugs, plug wires and condensers.
7. Any design alterations performed by an organization not authorized or specified by Windsor.
8. Battery and charger warranties are handled directly with the manufacturer (Trojan® batteries and Lester® chargers).
9. High-pressure washing.
10. Electrical components exposed to moisture.

If difficulty develops during the warranty period, contact the authorized Windsor agent from whom the product was purchased. Windsor Industries, Inc. may elect to require the return of components to validate a claim. Any defective part to be returned must be shipped freight prepaid to an authorized Windsor Distributor/Service Center or to the Windsor factory.

Use Of Parts Not Approved By Windsor Industries, Inc. Will Void All Warranties

This warranty is valid only for all products sold after July 1, 1995. A product sold before that date shall be covered by the limited warranty in effect at the date of sale to the original purchaser.