

FACTORY CAT

Model 40 & 40 HD Industrial Rider Scrubber

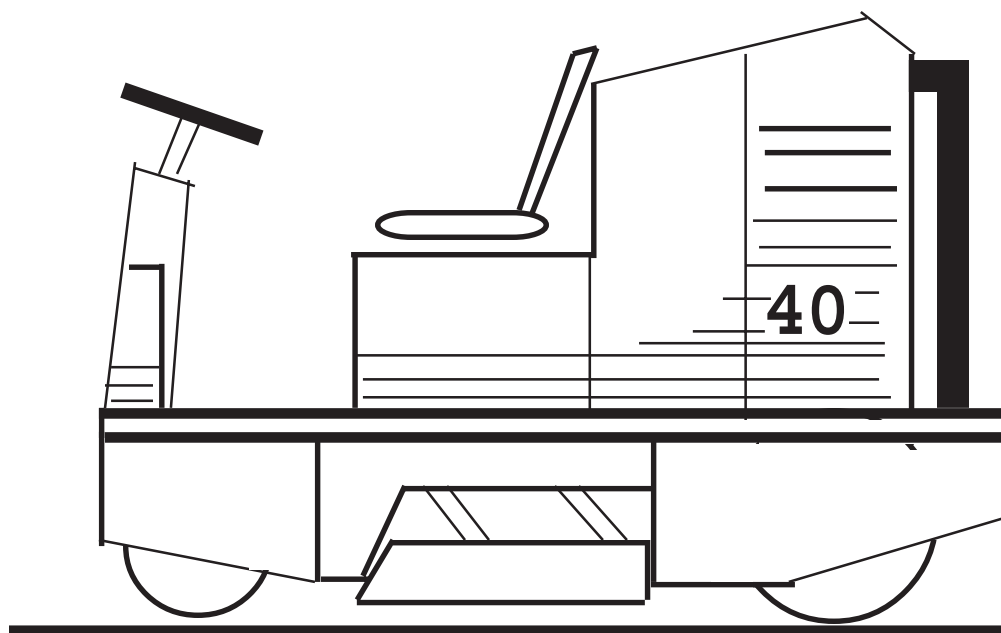

Operator 's Manual Parts & Service Book

PS-40.6-ENG

EDITION 6

FACTORY CAT MODEL 40 RIDER SCRUBBER

Operator's Manual & Parts Book: Edition 6

TABLE OF CONTENTS

READ THIS FIRST!

| | |
|-------------------------------|-----------|
| Safety Warnings: | Pages 2&3 |
| Short List of Do's and Don'ts | Page 4&5 |

OPERATING YOUR MACHINE

| | |
|--------------------------------|---------|
| Identifying the Controls | Page 7 |
| How It Works | Page 9 |
| General Operating Instructions | Page 10 |
| Cylindrical Brush System | Page 15 |
| Spray Jet and Vac Wand | Page 17 |
| Recycling | Page 19 |

SPECIAL OPERATING TIPS

| | |
|--------------|---------|
| How to Scrub | Page 22 |
|--------------|---------|

MAINTAINING YOUR MACHINE

| | |
|--------------------------------------|---------|
| Daily Pre-Check | Page 25 |
| Daily Clean-up | Page 26 |
| Squeegee & Vac System Adjustments | Page 27 |
| Cylindrical Brush System Maintenance | Page 28 |
| About Batteries | Page 29 |
| General Machine Maintenance | Page 30 |

TROUBLESHOOTING AND REPAIR

| | |
|-----------------------|------------|
| Central Command | Page 33 |
| Troubleshooting Guide | Page 35 |
| Electrical Schematics | After P 40 |

SPARE PARTS SECTION

Begins Page 41

Spare parts section has its own Index on Page 42

SAFETY WARNINGS!

THESE WARNINGS ARE NOT MEANT TO BE A COMPLETE LIST AND ONLY THE OPERATOR'S INTELLIGENCE, GOOD SENSE AND CARE OF UNIT WILL ASSURE THAT MOST HAZARDS WILL BE AVOIDED.

1. **READ THIS MANUAL CAREFULLY AND COMPLETELY BEFORE OPERATING, ADJUSTING OR REPAIRING THIS MACHINE.**
If you have a question concerning the machine or its operation, or would like extra copies of this book, you may call the Factory at 1- (800) -634-4060, or Fax your questions to us at 1- (414) - 632-3335. (Factory is on U.S. Central Time).
2. **CHARGING THE BATTERIES WILL PRODUCE EXPLOSIVE HYDROGEN GAS.**
Do not smoke or allow open flame near a charging battery. Do not smoke while working around the machine. Do not charge battery with the hood (lid) of the machine closed or hydrogen gas may accumulate within.
3. **TO AVOID ACCIDENTALLY STARTING UP THE MACHINE, ALWAYS TURN OFF THE KEY SWITCH BEFORE GETTING ON OR OFF UNIT. OTHERWISE BUMPING THE FOOT CONTROL COULD CAUSE UNIT TO START UP.**
A green warning light on the right-hand control panel shows when power is on.
4. **WHEN YOU LEAVE THE MACHINE UNATTENDED, ALWAYS SHUT OFF THE UNIT AND TAKE THE KEY.**
5. **DRESS SAFELY**
Do not wear rings or metal wrist watches while working on this machine. They can cause an electrical short, which, in turn, can cause burns.

Do not work on this machine while wearing a tie, scarf or other dangling neckware. These can tangle in rotating machinery and cause serious injury or even death.
6. **DO NOT USE THE MACHINE AS A STEP LADDER OR CHAIR.**
7. **IF YOU MUST LIFT UNIT OFF OF GROUND, DO NOT WORK ON UNDERSIDE OF MACHINE WITHOUT PROPERLY SUPPORTING UNIT.**
8. **NO RIDERS!** Model 40 was meant to carry only the operator.
9. **NO TIGHT, FAST TURNS!** While negotiating turns, reduce speed, steering in a smooth motion. *Do not turn around while on a ramp!*
10. **NOT INTENDED FOR USE ON STREETS OR SIDEWALKS.** Common sense dictates that driving in traffic is dangerous to the operator of a slow vehicle, while operation on sidewalks can endanger pedestrians.
11. **WARNING: DO NOT USE OR VACUUM UP FLAMMABLE CLEANING CHEMICALS. VACUUMING UP FLAMMABLE CHEMICAL FROM THE FLOOR CAN CAUSE AN EXPLOSION.** The vacuum motors can create sparks that will set off volatile chemicals.

12. **WARNING: 24 VOLT POWER CAN CAUSE BURNS. DO NOT DROP TOOLS ON LIVE CONNECTIONS. DO NOT WEAR JEWELRY WHILE WORKING ON ELECTRICALS.** Your machine is equipped with rubber covers over the battery terminals. Be sure these stay in good condition and continue to cover the terminals.
13. **BEFORE WORKING ON THE MACHINE, TURN THE KEY OFF, REMOVE KEY, AND DISCONNECT THE BATTERY.** Be aware that the brush and vacuum motors can start if someone else pushes on the foot pedal while the key is turned on, even though the machine makes no noise, and appears "off". **Do not work on machine while someone else is sitting in operator's seat. They could accidentally turn on the power while you work.** Be aware that when brushes are operating (cylindrical or disk) that whirling machinery could catch a necktie or scarf.
14. **ALWAYS UNPLUG CENTRAL COMMAND FROM BATTERIES BEFORE USING AN EXTERNAL CHARGER.** A power surge from a "dumb" charger could damage Central Command's electronics. This could destroy Central Command's ability to control traction motor speed, and could lead to a "runaway" machine. ***We do not recommend the use of a "dumb" (non-electronic) charger!*** If you must use one, you must be sure the battery pack is disconnected from the Central Command module before connecting the charger.
15. **STOPPING: UNDERSTAND THE AUTOMATIC BRAKING SYSTEM BEFORE YOU OPERATE THE MACHINE ON SLICK RAMPS.** Machine does not coast. Releasing pedal applies braking force. You control the amount of braking by the suddenness (or smoothness) with which you release the floor pedal. After you stop, the parking brake will set automatically.
16. **PARKING: MAKE SURE THE PARKING BRAKE IS WORKING PROPERLY BEFORE PARKING MACHINE. WE DO NOT RECOMMEND PARKING MACHINE ON RAMPS OR SLOPES.**
17. **TO AVOID TIPOVER, DO NOT MAKE TIGHT TURNS SIDEWAYS ON A RAMP. TURN AROUND ON FLAT GROUND OR FLOOR ONLY. DO NOT MAKE SHARP TURNS AT HIGH SPEED.**
18. **WHILE WORKING ON THE SQUEEGEE SYSTEM, BE SURE KEY IS REMOVED FROM KEYSWITCH.** Inadvertent operation by another person of the powerful squeegee lift mechanism while hands or fingers are in the way could pinch.
18. **DO NOT OPERATE THE MACHINE IF ANY PARTS HAVE BEEN REMOVED FROM IT.** Do not remove or paint over Warning decals. If Warning decals are damaged, they must be replaced.
19. **AUTHORIZED , TRAINED OPERATORS ONLY.** This machine should only be operated by a trained operator. As part of his training, he/she must read this manual thoroughly. If extra copies are needed, contact your local dealer, or the Factory directly at 1-800-634-4060.
20. **DO NOT OPERATE MACHINE IF IT IS IN UNSAFE CONDITION.**
If the machine is in need of repair or is in any way unsafe or contributes to an unsafe condition, the matter should be reported immediately to the shift supervisor. Do not operate the machine until it is returned to proper operating condition.

Model 40: SHORT LIST OF DO'S AND DONT'S

1. **AUTOMATIC OPERATION:** Key Switch must be on. When "Override" switch is in automatic mode, stepping on foot pedal will automatically:
 1. Release brake.
 2. Turn on brush motors (if brush head is down)
 3. Turn on vacuum blowers (if vacuum squeegee is down)
 4. Turn on the solution flow.
 5. Accelerate you forward.

2. **TO GO:** Step on the foot pedal. **Go Easy!** As with any electric vehicle, hard acceleration wastes power, and will run the batteries down sooner.

TO STOP: Let go of the foot pedal. The faster you release the pedal, the faster you will stop. Practice stopping smoothly.

When machine comes to a complete stop, parking brake will automatically set. **Go slow until you get accustomed to the automatic braking. Allow at least one machine length to come to a stop on level ground, more on hills.**

3. **DO NOT "SLAM-SHIFT" OR "PLUG".** This machine has dynamic braking. Always come to a full stop before shifting from forward to reverse, or from reverse to forward.

4. **TO SCRUB:** The brushhead has to be lowered, and the brushes on the ground. Brushes will start and stop with the foot pedal (in automatic mode). You can build pressure on the brushes with the brushhead switch. **REMEMBER THAT EXCESS BRUSH PRESSURE WASTES BATTERY POWER AND WILL GREATLY LOWER RUN TIME ON A CHARGE.**

5. **TO SQUEEGEE** Lower the squeegee. Vacuum will start when you step on the foot pedal (in automatic mode), and will stop 21 seconds after you release the pedal. Squeegee will automatically lift when you select reverse.

6. **DON'T RUN BATTERIES ALL THE WAY DOWN!** Machine will begin to slow down--a lot--as batteries near the end of their charge. It is a bad idea to run the battery this far down. Watch the battery gauge on the left side of the operator's seat. Stop before "Empty".

7. **TO RECHARGE:** To recharge battery, be sure the key switch is off. Open the hood, and plug in the external charger supplied with the machine. A green light will come on. When the light goes out, battery is charged. **LEAVE THE BATTERY BOX COVER OPEN WHILE THE BATTERY IS CHARGING.**

8. **CLEAN OUT THE MACHINE AT END OF DAY.** You can inspect the recovery (pick-up) tank's condition by opening the door on top and looking in. If after you flush it out there is still dirt on the bottom, open the clean-out door and clean out using water. If your machine is equipped with Cylindrical Brushes, remove hopper and wash it out.
9. **NEVER USE FLAMMABLE OR EXPLOSIVE CHEMICALS IN THE MACHINE.** Sparks from the vacuum motor will ignite flammable fluids kept in the tank. This could cause an explosion. Such chemicals include, but are not limited to cleaning fluid, gasoline, kerosene or other petroleum-based products. If in doubt about flammability, refer to the chemical product's M.S.D.S. sheet before using.
10. **DO NOT DRIVE MACHINE OVER BUMPS MORE THAN 2" HIGH UNDER ANY CIRCUMSTANCES.** If in doubt, get off the machine to check clearance with the brushhead of the unit.
11. **USE ONLY LOW-FOAMING DETERGENT.** Foam shortens the life of vacuum motors. Use of high foam detergent may eliminate warranty coverage of the vac motors. If in doubt, call **Factory Cat** at 800 634-4060 for advice.
12. **MUST SCRUB GREAT.** No kidding, Model 40 is the world's best compact rider scrubber. If your scrubber isn't scrubbing really well, or seems hard to use, or is making funny noises, something is wrong. Here's what to do:
 - A. **Read this book.**
 - B. **Then call your dealer for info or service.**
Or you can call us at the Factory toll free: 1-800-634-4060.
We'll talk you through the problem.

OPERATING YOUR MACHINE

CONTROLS & FUNCTIONS

1. **Foot Pedal:** Controls Forward speed and braking. Also turns on and shuts off solution, brushes, and vacuum when "Auto/Manual" switch is in "automatic" mode.
2. **Yellow "Low Solution" Light:** Glows when Solution tank is nearly empty. (Option--not on all machines).
3. **Red "Recovery Tank Full" Light.** Glows when Recovery Tank is full. (Option--not on all machines).
4. **Brush Downpressure Indicator.** Shows relative pressure on the brushes by vertical LED readout.
5. **Squeegee Lift Switch.** Lifts and lowers squeegee and turns the recovery tank's vacuum on and off automatically.
6. **Brush Downpressure Switch.** Pushing on the front edge of this switch lowers the brushes, and, when they reach the floor, increases pressure. Pushing on the back reduces pressure and then raises the brushes off the floor.
7. **Vac "On" Switch.** Normally, the vacuum will work only when the squeegee down, and after the foot pedal has been depressed. When the Vac switch is "on" however, the vac motors will run constantly, so that the remote vac hose (an option) can be used.
8. **Solution Flow Control. *On early machines.*** Varies the amount of solution that is laid down on the brushes. Pull up on the knob to increase solution flow.
- 8A & 8B **Solution Flow Control. *On new machines,*** switch permits cutting off solution flow. Turn knob counter-clockwise to increase flow. Adjust flow knob only after turning off switch.
9. **Power-On Light.** Glows green when the key is on and battery power is available.
10. **Forward-Reverse Switch.** Push the forward edge of the switch to go forward, and the back to reverse. In reverse mode the squeegee will automatically lift. ***Do not shift from forward to reverse unless you are stopped!!!***
11. **Key Switch.** Insert key and turn either direction to turn power on.
12. **Battery Indicator.** Shows relative battery strength with an LED readout--like a fuel gauge. Note that this gauge will reset to "full" whenever you unplug the batteries, whether or not the batteries are recharged. ***When light flashes, you must stop to recharge!***
13. **Hour Meter.** Runs when keyswitch is on.

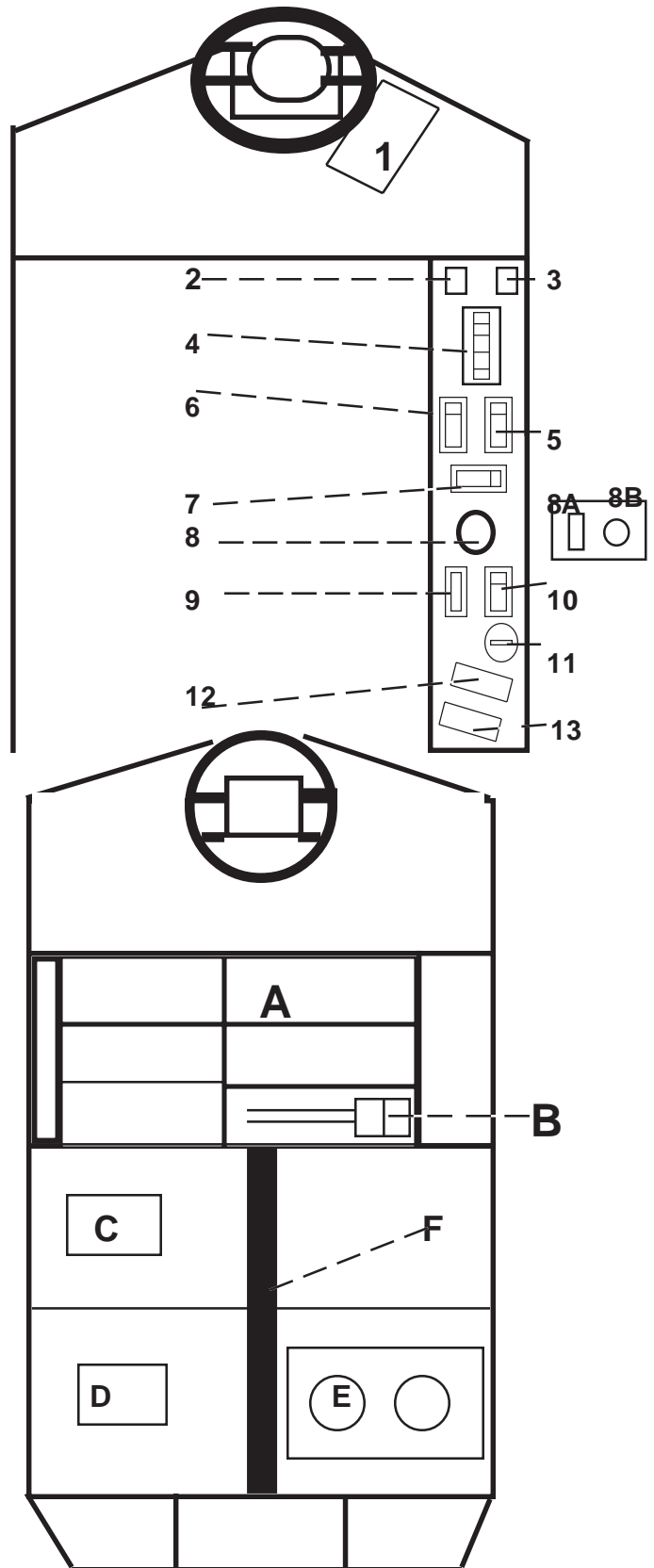

COMPONENT LOCATIONS

- A. **Batteries.** (Under the Operator's Seat. Check water every two weeks. Read battery section of this book.
- B. **Battery Connector** (Red 175 Connector). Disconnect this from the Central Command control panel, and connect to the charger to recharge batteries.
Leave the battery box door open during recharging!
- C. **Solution Tank Door.** Add detergent and water here.
- D. **Recovery Air-Out Door.** Used for daily clean-up and flushing out of the Recovery Tank.
- E. **Vac Motor Housing.** Vacuum motors for recovery are kept here. Open the box for access.
- F. **Tank Retaining Strap.** This black polypropylene strap keeps the solution and recovery tanks (which are removable) in place. The strap tensioner, which is at the base of the rear bumper, is adjustable.
- G. **Recovery Drain Hose.** Drain and flush out the recovery tank every evening. If necessary, clean out the tank using H.
- H. **Recovery Cleanout Door.** Gives access to tank interior. Do not open until tank is first drained. Be sure you clean the sealing surface before clamping the door back on or door may leak.
- I. **Recovery Hose.** Connects between squeegee and recovery tank. Hose is easily removed if clog occurs. Clog will generally occur at the squeegee.
- J. **Squeegee.**
- K. **Squeegee Pitch Adjustment.** Adjust for maximum effectiveness. Moves front of squeegee up and down.

In general, back blades of squeegee must touch the floor in the corners. If squeegee trails in the middle--it is pitched too far forward. If it trails at the edges, it is pitched too far back.

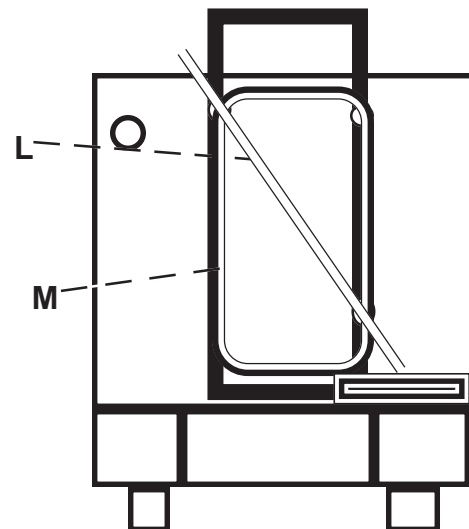
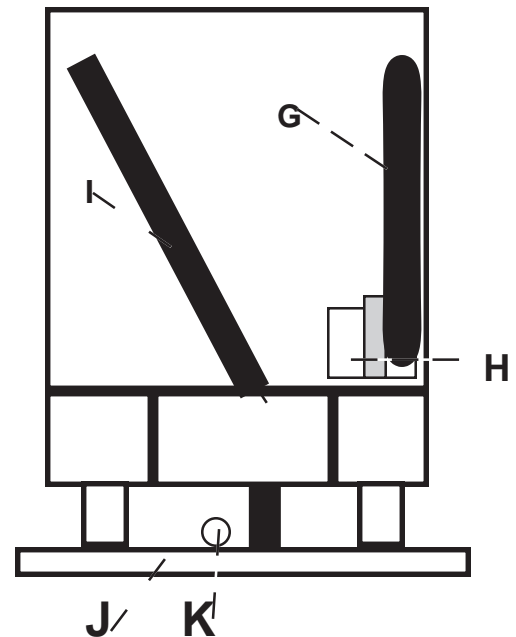
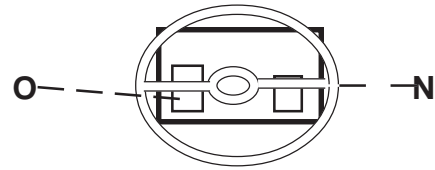

- L. **Optional Vac Wand.** Unplug (I.) Recovery Hose, and plug in this wand for remote cleaning. Stores as shown on bumper-mounted bracket.
- M. **Optional Vac Wand Solution Hose** Black solution flow hose for wand starts Behind left corner of bumper.
- N. **Pump Switch for Optional Vac Wand.** Turn on for solution flow. Found under steering wheel. **Be sure to turn the pump off when it is no longer needed!**
- O. **Switch for Optional Side Brooms.** Switch lowers brooms and turns them on.

HOW IT WORKS

1. **Disk Scrub brushes**, under machine, rotate toward center of machine. Pressure is applied to them by the operator down pressure control. *If your machine is equipped with **cylindrical brushes**, see section on them that follows. **Disk brushes** are flat, round disks used for scrubbing only. **Cylindrical brushes** are long tubes with short fiber on them. Machines so equipped can sweep at the same time they scrub.*
2. **Solution** (detergent and water) flows from the solution tank just behind the operator, via plumbing to the brushes.
3. The solution and brushing clean the floor.
4. **The squeegee**, at rear of machine, picks up the dirty water from the floor.
5. **The recovery tank** stores the dirty water for later dumping.
6. **The rear wheel drive system** uses a variable speed motor. The motor drives a transaxle, and through it, the two rear tires. The motor's speed, rate of acceleration and deceleration are controlled through the "Central Command" system located in the control panel on the operator's right-hand side.
7. When the operator lets up on the foot pedal, Central Command brings the machine to a smooth stop, and then automatically sets the parking brake on the transaxle.

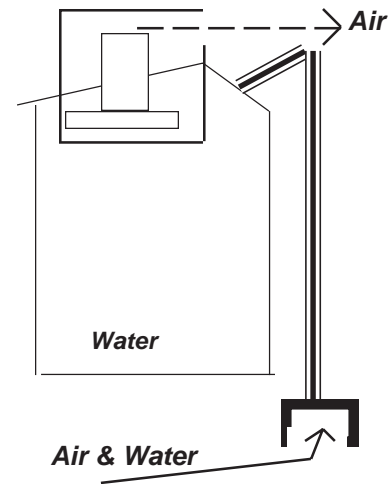
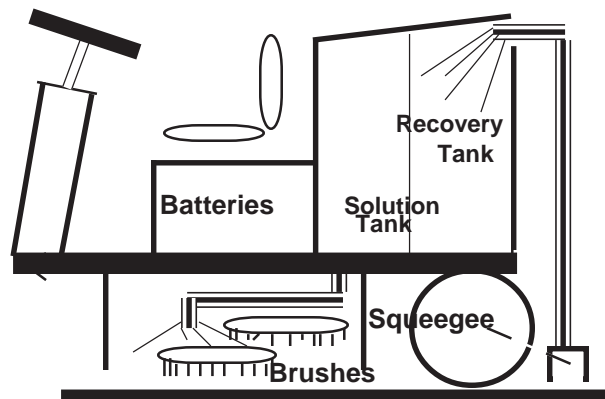

Motors in the top of the tank create vacuum, which pulls through the squeegee.

8. Power for the brushes and vacuum impellers come from individual motors.
9. Central Command turns these motors on whenever the foot pedal is depressed, and turns them off after the scrubber comes to a stop (in "Auto" mode only).
10. All motors take their energy from a 24-Volt deep-cycle battery set.

OPERATING INSTRUCTIONS

- PLEASE READ WARNINGS ON PAGE TWO OF THIS MANUAL CAREFULLY.**
Refer to Page 4 for Location of Controls.
- To make the machine move under its own power--without scrubbing**
--Turn on Key Switch.
--Make sure brush head is off ground.
(See Steps 5 & 6 Below)
--Gently step on foot pedal.
- To stop: Let go of foot pedal.**
Machine will automatically come to a stop. At this time, the parking brake will be automatically set by the machine's Central Command unit.
- Solution:**
To save expense, use the least amount of solution that will do the job.
New Machines: Turn the dial counterclockwise for more. Turn switch off when making a tight turn to avoid leaving water.
If you would like more or less solution on the floor than the system now provides with the dial, remove the setscrew from the dash board, and turn the dial past it. Then put screw back. Dial has total of eight turns available from fully closed to fully open; one of these eight turns is selected for each application. However, do not use system with screw missing because an operator could twist the knob too hard for the cable to overcome.
Older Machines: Pull out the solution flow knob until you have the desired amount.
- To scrub:**
Be sure you have solution in the solution tank. While driving forward slowly, push on the brush up/down control until you read the desired brush pressure on the LED readout.

SPECIAL NOTE: The more down pressure you use, the faster you will consume battery power. Use the LEAST AMOUNT of pressure that will do the job.
- To vacuum up the solution:**
Turn on the squeegee and vacuum with the squeegee switch.
Note that when you turn this switch off, the squeegee will quickly raise, but the vacuum will continue to operate for about 21 seconds. This is to clear the pickup hose of solution.

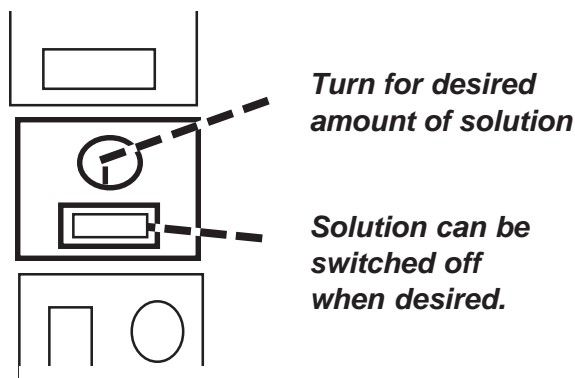

Turn for desired amount of solution

Solution can be switched off when desired.

SCRUBBING TIP 1: Save Battery Power!

The main consumer of power on your scrubber is the scrub brushes. The more pressure you use in scrubbing the faster the batteries will wear down. Use the least amount of scrub pressure that will do your job, and you will be able to scrub more on a charge.

SCRUBBING TIP 2: Save the Juice!

The solution that flows through your scrubber can cost more than the scrubber itself over time. Do not overmix solution--don't use more detergent than necessary. Often, using too little water with your detergent will lower the effectiveness of its cleaning.

Limit the solution flow to the minimum needed. Generally speaking, the less solution you use, the faster the vac system can pick up what's on the floor.

SCRUBBING TIP No. 3: Save the Brushes

The brushes used for scrubbing are plenty tough, but plenty expensive as well. The less pressure you use, and the less aggressive the solution, the longer the brushes will last.

Reverse the brushes daily!

It is a good idea to rinse off the brushes at the end of the day, and to remove accumulated wire and thread that may be caught in them. They are easy to remove.

OPERATING INSTRUCTIONS

6 To Double Scrub

Especially when you first start using your new scrubber, you may find the floor of your building especially dirty. It may be necessary to "double scrub" to really clean the floor. To double scrub, simply turn off the vacuum system (raise the squeegee), and slowly scrub back-and-forth over the same area several times. Once you have laid down solution, you can shut off the solution flow with the black knob. All you need is "enough" solution. Too much just wastes money.

7. Vac Switch

The Vac Switch allows the vac motors to run constantly--instead of only after the foot pedal is pushed--so that the remote vac wand can be used.

When this switch is in the on mode, vacuum will run continuously until switch or key switch are turned off.

8 Watch Out For Low Battery.

NOTE: The Central Command unit will cut power back when battery voltage gets too low. Low voltage could otherwise damage the motors.

Don't let this happen to you. Return back to base for a recharge as soon as the battery gauge shows you nearing empty. Depending upon the batteries your machine has on board, and how hard you work the machine, you should have between three and eight hours of run time on a charge.

9 Safety Motor Stop

The Central Command unit will turn off the brush motors momentarily if one of them is overloaded. The brushes will turn on by themselves if you raise the brush head, and wait 30 seconds before continuing to scrub. This Safety Stop is most likely to occur if you start scrubbing on a dry floor with too much down pressure.

To Clean the Recovery Tank:

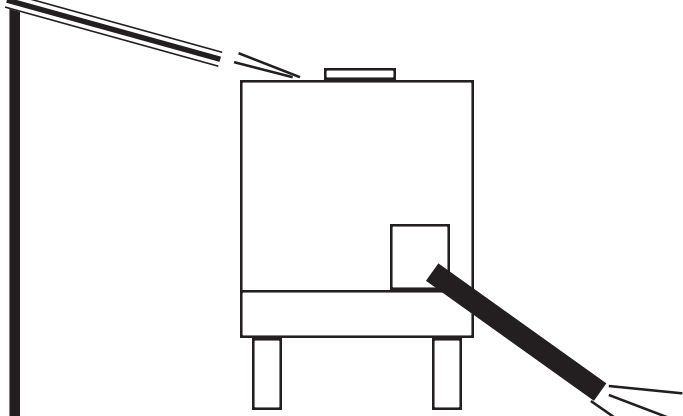

Use the drain hose at the rear of the machine to empty the tank, then, with the drain hose still in place, use the "flush-out" door on top of the tank to rinse out the tank. Inspect the tank through the airtight door. If necessary, you can scrape out the tank through the cleanout door.

RECHARGING: SAFETY TIP

- 1 To charge the batteries, you must turn the Key Switch off and disconnect the Batteries from the machine. Otherwise you could damage the Central Command.
- 2 Always Leave the Hood (Lid) open when recharging. Otherwise, explosive hydrogen gas could build up inside the battery box.

Battery Condition Meter

See Page 4, Item 3.

This gauge shows the relative condition of the battery, and reads like a fuel gauge in a car. Stay above empty!!!

PLEASE NOTE This meter shows *relative* charge. If you unplug the batteries while the batteries are low, and then replug them into Central Command, you will "fool" the battery gauge into thinking they are fully charged.

To correct the gauge, recharge the batteries, then unplug and replug the battery set's Grey 50 connector.

OPERATING INSTRUCTIONS

10. Recharging Battery

Using the Factory Cat Supplied Console-Type Charger:

- *Turn off the machine
- *Open the battery box.
- *Unplug the Red 175 connector between Central Command and the batteries.
- *Plug the charger's Red 175 terminal into the battery pack.
- *Leave the battery box lid open during charging.
- *Plug in the charger to a wall outlet with the correct voltage.
- *The charger's charge gauge will show a positive reading.

In North America, our chargers are usually equipped for single-phase 110 Volt, 60 Hz. operation, the same power as used in houses. The three prong-plug requires a grounded outlet. Do not use without grounding. This Factory Cat charger is completely automatic. Its electronic circuitry will tell it when the battery is charged, and to shut itself off.

NOTE, however, that if the batteries are allowed to run down to below **18 volts**, the automatic charger will not start its charge cycle. You must then bring the battery voltage back to 18 or more volts. You can normally do this by running the charger through **TWO** complete charge cycles without using the machine until the second cycle is complete. In this process, the first cycle will bring the voltage up to 18 or 20 volts, and the second charging will bring it back up to system voltage (about 26.4 volts).

USING AN EXTERNAL BATTERY CHARGER:

If, for some reason, you must use an external charger, **disconnect the batteries** using the "Red 175" connector provided. **Otherwise you can seriously damage the Central Command module.**

NOTE: Some battery chargers are not automatic, and will not shut off when the battery is charged. You can seriously damage a battery by overcharging it.

NOTE 2: Non-automatic chargers generally have a dial on the front where you can select the amount of time for the charge. If you **MUST** use a manual charger, always select a low setting. Battery warranty will be voided if you overheat the batteries through use of such a charger.

BATTERY SAFETY WARNING!

Charging a battery produces explosive hydrogen gas.

Leave the battery box lid open while the battery is charging to avoid buildup of gas inside machine.

Do not smoke or expose open flame or spark to area around battery during charging.

Follow the instructions that came with your charger. Factory Cat chargers are automatic, However many chargers are not automatic and can over-heat the battery if not properly set. *Such overcharging will void the warranty on the batteries.*

Watch for battery acid! If acid gets in the eye, wash out with water for twenty minutes and call a physician.

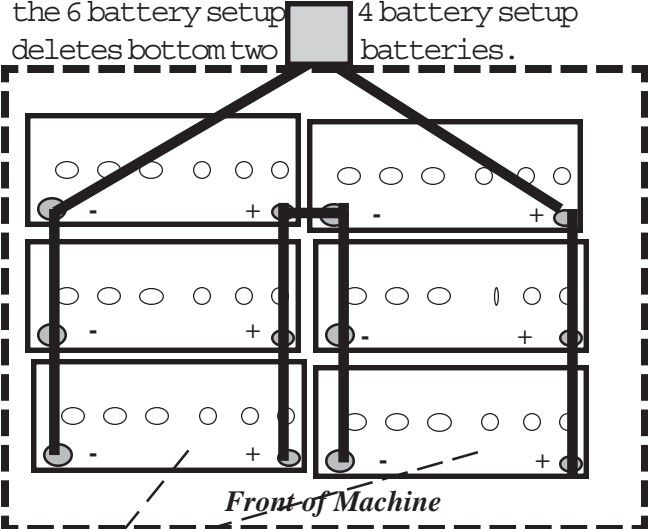
Battery Layouts: Battery posts must face as shown. System is 24 Volts. This shows the 6 battery setup  4 battery setup deletes bottom two batteries.

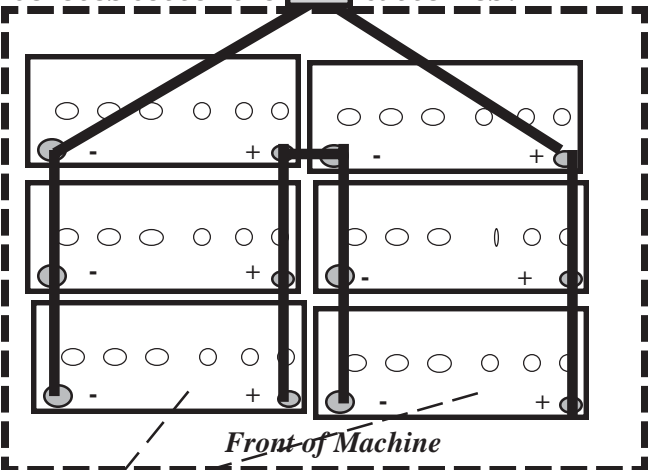

Four battery setup is missing these two batteries.

TECH TALK: The top two batteries are in series, while the bottom four (bottom two on some machines) are in parallel with the first two.

OPERATING INSTRUCTIONS

Brake System:

Model 40 has two separate braking systems:

For Normal Stopping:

Model 40 stops quickly and smoothly when the operator lifts his foot from the foot pedal. The faster he lifts his foot, the faster the machine stops.

For Emergency Stops and Parking:

In addition an automatic emergency & parking brake is provided. This brake operates directly on the transmission, and affects both the rear wheels. The emergency/parking brake will engage automatically under any of these three conditions:

1. About 3/4 second after the operator releases the foot pedal and the machine comes to a stop.
2. About 1/4 second after the key switch is turned off.
3. If a power failure occurs.

This automatic emergency & parking brake is spring-engaged. It is released by an electric solenoid. The solenoid is operated by the *Central Command* energy management system.

To Check the Brake System:

Never park on a ramp without being absolutely certain that the automatic parking brake works properly. You can check the emergency parking brake by trying to push the machine on level ground when the key is off. If you can push it, then the brake system needs checking.

Releasing the Automatic Brake

Since the parking brake is automatic, Model 40 cannot and should not be pushed by hand.

If you need to move the machine, and it cannot move under its own power (for example if the batteries are discharged) you must first release the parking brake. This is done by pulling on the **brake release lever** as shown in the right column. (Note the difference between early and late machines).

DO NOT push the machine without first releasing the brake. Do not drive the machine under power with the emergency/parking brake disengaged.

TO RELEASE THE AUTOMATIC EMERGENCY & PARKING BRAKE:

On Machines built after April 1, 2000:

Manual brake release is inside lefthand portion of bumper. Pull lever out and twist to lock open. **BE SURE TO RELEASE LOCK OR PARKING BRAKE WILL NOT WORK.**

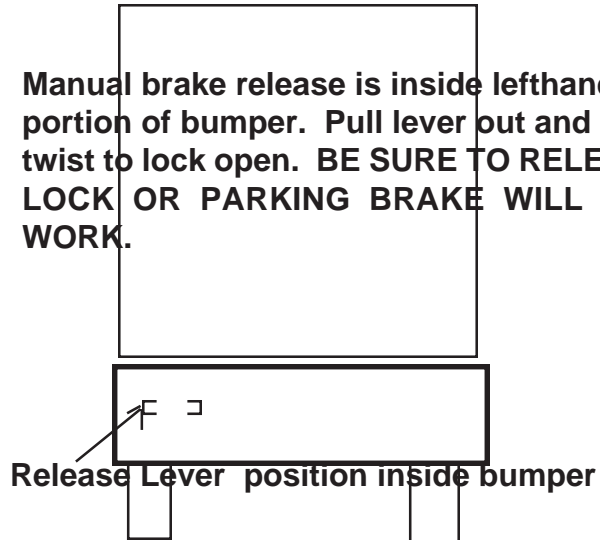

On Machines built before 4/1/2000:

Pull the Brake Release Handle outward as shown.

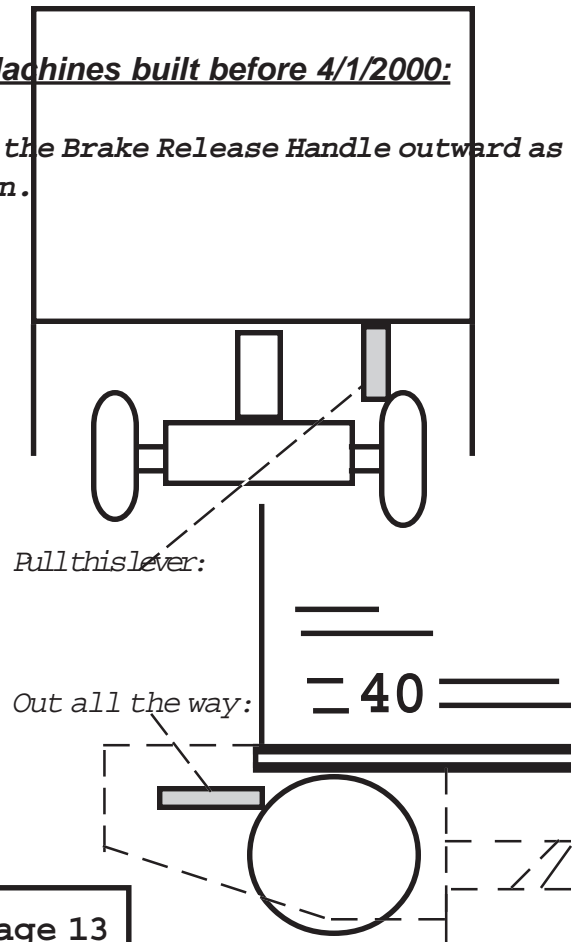

TRANSAXLE SHIFTING

Most units built before April, 2000, are equipped with a multi-speed transaxle. Use of the transaxle shift lever permits increasing climbing ability of the machine.

(Units built after April, 2000 have a single speed).

TO INCREASE CLIMBING ABILITY and/or TO LIMIT SPEED:

Push the shift lever IN as shown.

Top speed will be about 3.0 MPH

TO INCREASE TOP SPEED

Pull the shift lever OUT as shown.

Top Speed will be about 4.5 MPH.

NOTES:

1. **Turn off the key switch before shifting gears, and take the key out of the switch.**

(Otherwise someone else could inadvertently turn the machine on while you are shifting gears behind the machine. If they hit the squeegee or reverse switch, the powerful squeegee lift system could catch your hand or arm and pinch it).

2. Never attempt to shift gears while machine is running.
3. Never attempt to shift gears while machine is on an incline.

Machines built before 4/2000 have a two speed rear axle.

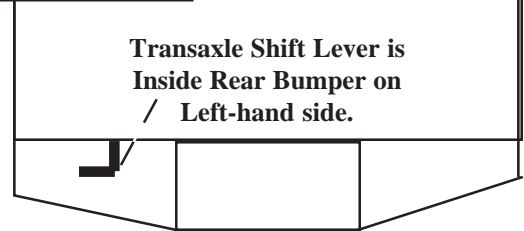

↑ Push *in* For Low Range



↓ Pull *out* For High Range

CYLINDRICAL BRUSH SYSTEM

The Optional Cylindrical Brush system sweeps and scrubs simultaneously. The "C.B.S." brush head replaces the disk brush system. It includes one motor, two cylindrical brushes, and a dirt hopper.

OPERATION:

The Cylindrical Brush Head operates like our conventional disk brush head. Pushing down on the front edge of the brush pressure button raises pressure. Pushing down on the back lowers pressure, and will eventually raise the brushhead off the floor.

Too much pressure can cause the system to shut down automatically because of overload. In this case, back off on the pressure. Use the gauge as a relative indicator.

The brushes can only turn when you step on the foot pedal. It is important that you make sure the machine is always moving when the brushes run.

Brushes and soap solution flow will both stop when the machine stops.

You should periodically empty the dirt hopper and clean it out. To do this, open the righthand door, and twist the handle in the hopper until the back of the hopper moves toward the rear of the machine. Then slide the hopper out of the machine.

Clean the hopper at the end of the machine's work cycle--whether or not it is full. Wash it out carefully. If you let dirt harden inside it will be much harder to clean out next time.

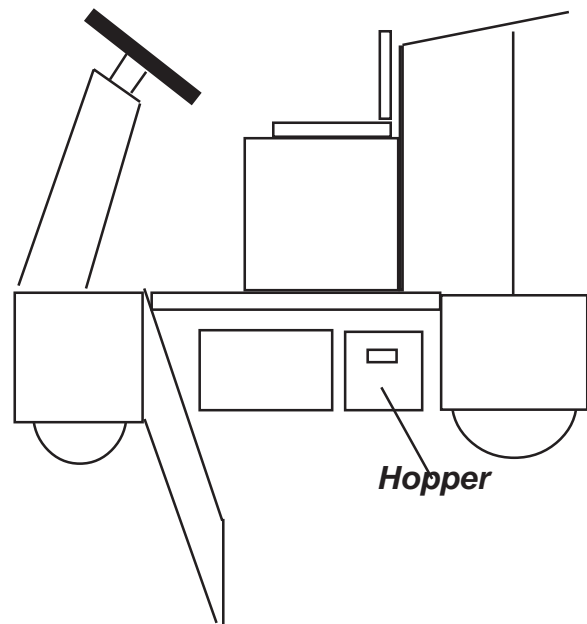

Twist handle counterclockwise, then pull

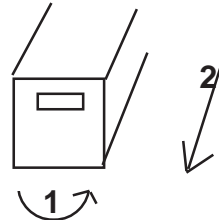

To change cylindrical brushes:

Open righthand door on machine.

Remove inner door, which is held on with four wing nuts. Do not lose the fasteners!

Pull the brushes out.

Put new brushes in place. Push against driver on other side of machine with tube and rotate tube slowly with your hand. If need be, go to other side of machine and reach around bottom of brushhead to seat brush on mount.

BRUSHES TO USE

The cylindrical system offers three brush types

1. **Soft Nylon** for use on finished floors. Bristles are clear or white in color.
2. **Grey Grit**, for general purpose cleaning on concrete and other less sensitive surfaces. **BE CAREFUL AS GREY GRITS MAY DAMAGE SOME SENSITIVE SURFACES.**
3. **Green Grit**, for very heavy cleaning in industrial settings. **THESE WILL DAMAGE A SENSITIVE SURFACE.**

If your cleaning conditions are harsh enough to need green grit brushes, we recommend you first try using just one green grit--for the front brush, followed by a grey grit. This combination will sweep much better than two green grits. The green grits are too stiff to "flick" many light objects into the hopper.

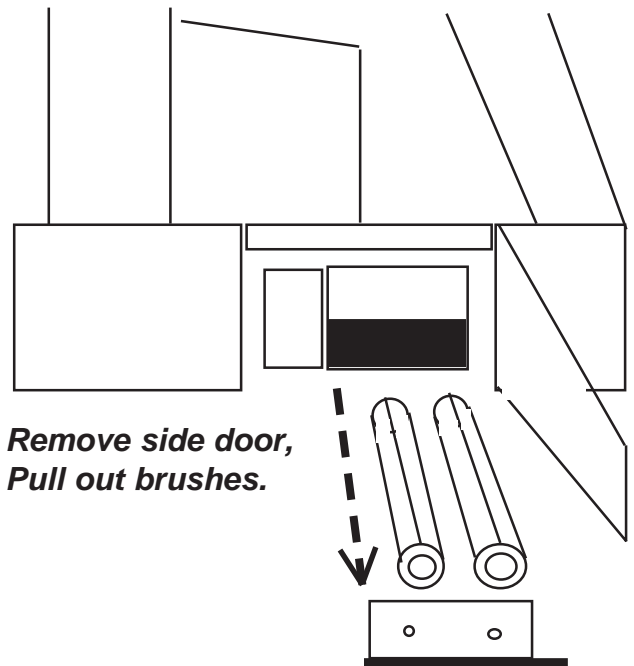

**Remove side door,
Pull out brushes.**

CYLINDRICAL BRUSH SYSTEM MAINTENANCE:

Please also see Page 30

DAILY:

1. Empty and wash out the dirt hopper every day.
2. If you scrub hard, the brushes will last longer if every day you move the front brush to the back and the back brush to the front.

This brush rotation is not appropriate if you are using a combination of brushes, such as green grit in front and grey in the back.

WEEKLY:

1. Measure brush length. Bristle must be 1/2" long or longer. (New brush fiber is one inch long). Replace brushes as needed.

MONTHLY:

1. Remove black side cover on lefthand side of cylindrical unit.
2. Inspect chain. Chain is lubricated, with special silocone grease and is maintained in place by non-adjustable sprockets and a spring-loaded tensioner.

SPRAY JET & VAC WAND

Model 40 is available with either the **Spray Jet**--a pump powered system that permits spraying solution into remote areas--or a **Vac Wand** that permits pickup in remote areas--or both together.

Both systems are options. Either system includes a rack mounted on the back bumper.

SPRAY JET: System comes with 12 foot hose, and an automatic pump that responds to pressure in the system. It pulls solution from Model 40's solution tank. Pulling on the "trigger" on the spray nozzle will automatically turn on the pump--when the pump switch is on.

To operate:

1. Turn pump switch on. It is located under the steering wheel.
2. Pull the black solution flow knob up all the way.
3. Aim carefully.
4. Pull the trigger.
5. Be sure to turn steering column switch off after you are done.
6. **Never run system dry!** You could destroy the pump!
7. **Never let water in pump freeze!** If machine must be stored in freezing temperature, add antifreeze to solution tank and let flow through the system.

SAFETY WARNING: *Never spray at or near co-workers. The solution in your Model 40's solution tank could be harmful to people.*

Pump Switch is here

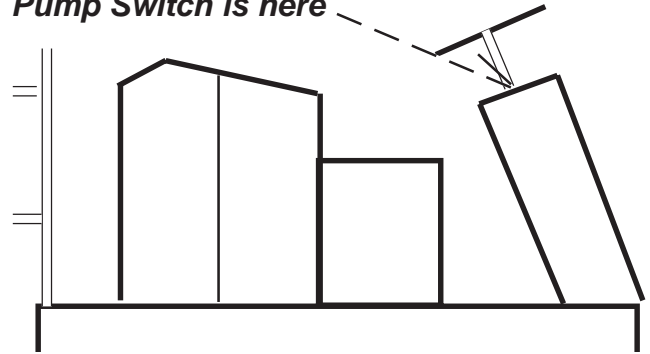

RACK STORAGE:

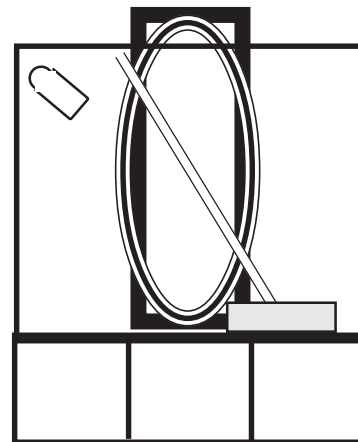

Vac hose and/or spray jet hose store on same rack. A nylon strap at the top holds items in place.

Clamps are supplied to hold the vac wand in place. Its nozzle mounts toward bumper.

VAC HOSE

The vac hose plugs into the recovery tank and uses system vacuum. The tool furnished with the system squeegees up water efficiently.

The first time you use the wand, you must adjust the squeegee wheels. Use the knob on the base of the vac nozzle. Set properly, wheels are set a bit below base of squeegee blade. Try it and adjust. Should vacuum perfectly both pushing and pulling the wand.

To operate vac wand:

1. Unplug Model 40's red vac hose where it plugs into recovery tank.
2. Plug in the black vac hose to the tank--and the other end to the wand.
3. Auto manual switch must be in manual mode.
4. Squeegee must be lowered (to turn on vac motors).
5. Put tools back neatly after use. Tie hose at top with nylon buckle and belt provided. Clamp wand securely into its two clamps.
6. Plug red hose back into tank.

To use Remote Vac Wand, disconnect Squeegee's hose, then plug vac hose in here

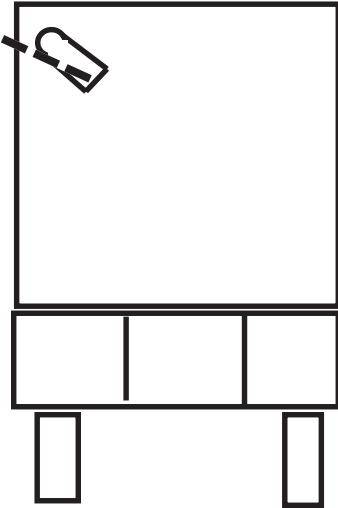

Adjust Nozzle Wheels so Squeegee works efficiently both pushing and pulling.

Knob at rear of nozzle tool adjusts tool wheels so squeegee rubbers touch floor properly.

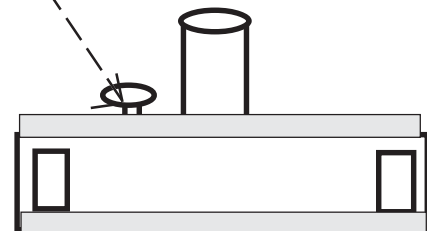

RECYCLING SYSTEM

This system is optional on Model 40. It can be field installed as well as Factory installed.

WHAT IT IS

The recycling system is intended to extend the time the machine can operate on a tank fill by reusing solution.

This system is intended for use in relatively clean environments. Dirty water is not as effective a cleaning agent as clean water.

HOW IT WORKS

When switched on, it pumps solution from the recovery tank, and adds it to the solution tank. A filter inside the recovery tank removes most of the grit in the water.

An automatic switch in the recovery tank switches on the pump when the tank is about three-fourths full. An automatic switch in the solution tank switches the pump off when the solution tank is about three-quarters full.

TO OPERATE THE SYSTEM

Fill solution tank as you normally would. The recycling system's cover acts as the door to both tanks. Unscrew clamps and raise the lid.

You can also, at your option, fill the recovery tank no more than half full.

Switch on the switch on the outside of the housing.

When you notice that the machine no longer cleans satisfactorily, change the water in both tanks.

TO MAINTAIN THE SYSTEM

Very important: The filter in the recovery tank must be cleaned after every day of use. **You must never operate the recycling system with the filter missing.**

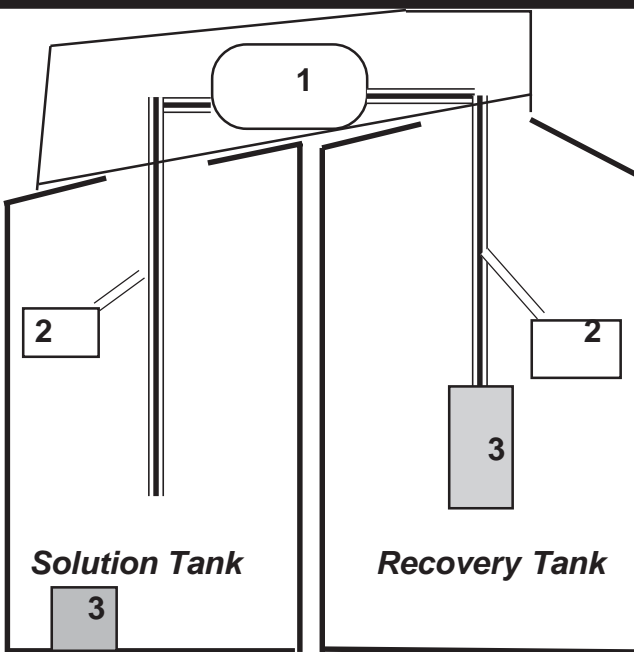
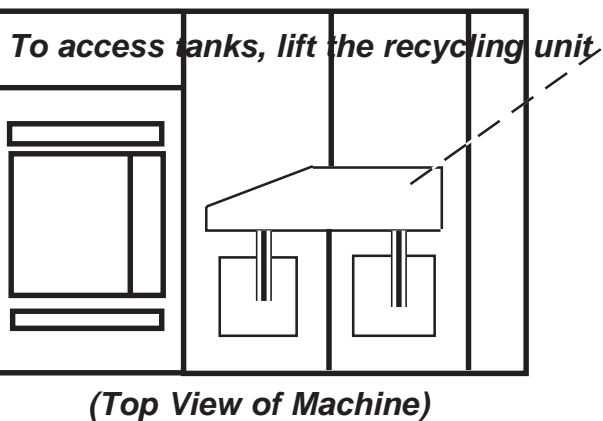
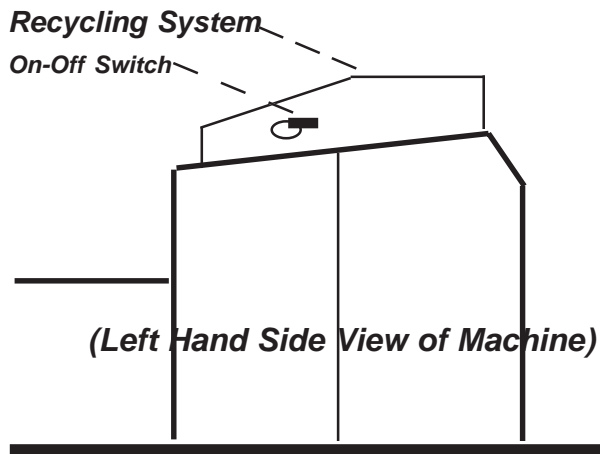

Explanation: 1 = pump; 2 = magnetic float switches; 3 = filter

RECYCLING (Continued)

To remove filter for cleaning:

1. Pull the two levers in the recovery tank hose mount down to release the hose.
2. Hose can now be withdrawn from top of tank.
3. At your option, you can also unscrew the filter from the hose.
4. Filter is to be washed with clean water. If necessary, brush filter screen with light brush, such as a tooth brush.
5. Never use a filter that is visibly damaged!

CLEANING OUT THE SOLUTION TANK

What goes in must come out. The grit that is fed into the solution tank will eventually build up.

The solution tank's filter is arranged so that about an inch of grit can build up in the bottom of the tank before the filter is affected.

Before the grit reaches this filter, you should clean out the tank as follows:

1. Remove the solution tank filter.
2. Open the solution tank dump valve (directly underneath the tank on the lefthand side).
3. Flush out the tank with a hose.
4. **Put filter back in tank before using machine again!** Otherwise you can clog the brush system's electro-valve.

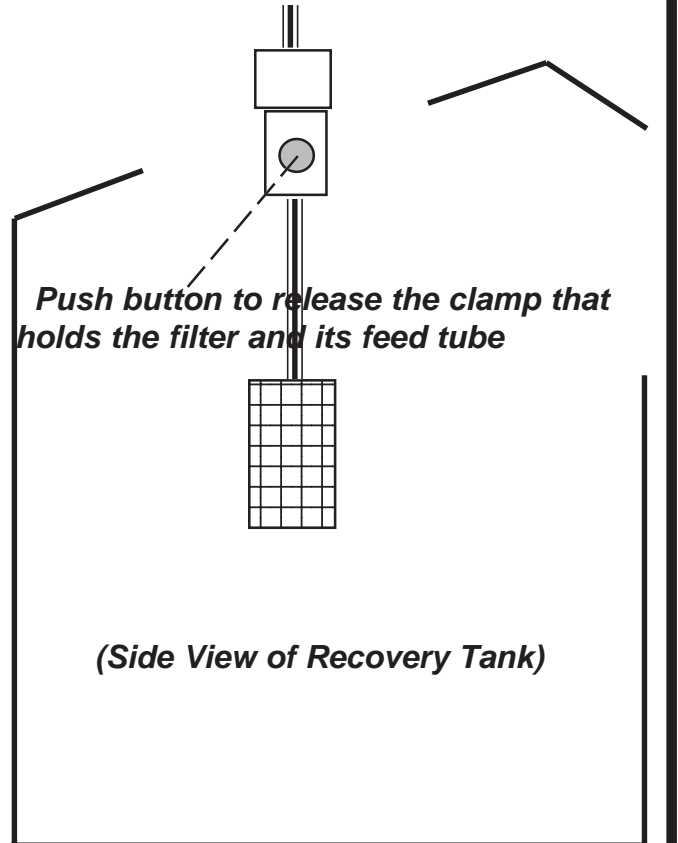

OPERATING SYSTEM WITH FILTER OFF COULD VOID YOUR WARRANTY

Never operate recycling system with filter off. Doing so will clog all downstream plumbing, and possibly damage the machine's flow valves.

Take care of the filter, and the system will work well for you. Don't take care of it, and you'll have problems.

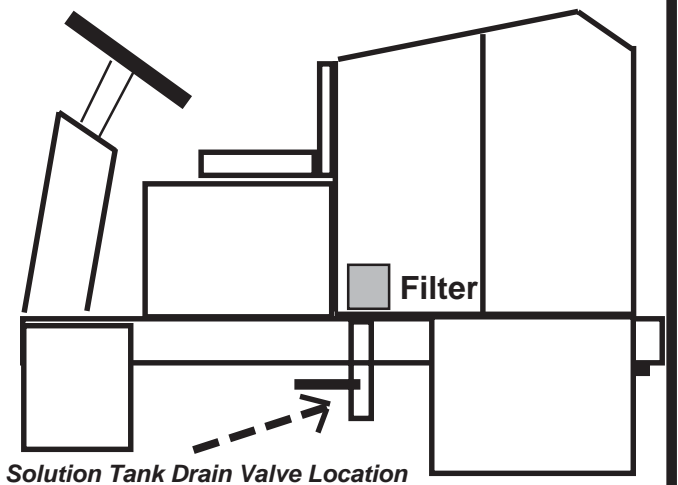

SPECIAL OPERATING TIPS

HOW TO SCRUB

Good Scrubbing Requires:

1. **Knowledge of your floor surface.** What is it sensitive to? Be careful not to use chemicals that will hurt the floor surface, or to apply too much brush pressure or use the wrong kind of brush on your floor.
2. **The right chemical.** The chemical does most of the work. There are chemical formulas made specially for General Cleaning, Emulsification & Removal of Oil, Polishing, Removal of Tire Marks and others.

Maintain the "M.S.D.S." sheet that comes with the chemical you use in a specific place in your plant. that is known to others on your own and other work shifts.

For safety's sake, you must never use flammable chemicals in the scrubber. Arcing inside the vacuum motors could create an explosion.

For safety's sake, you should not use chemicals with potassium hydroxide in the formulas if you will be picking up aluminum particles. This material mixes with aluminum to form hydrogen, an explosive gas.

3. **The right brushes.** Factory Cat can supply you with many different brush types to suit your application. Four of the most popular brushes are:
 1. **Nylon.** Soft, and long lasting, but can't scrub hard.
 2. **Poly.** Scrubs harder than nylon. Still pretty soft.
 3. **Nylogrit.** Flexible bristles combined with grit.
 4. **Stratogrit.** Tough, non-flexing bristles, combined with grit. Recommended for tough, industrial applications. Best for removing build-up.

Brushes are very expensive, but, treated right can have a long service life. We strongly recommend that you remove your brushes from the machine after each day's work. Clean them off with cold water. Remove entangled wire, and etc, from them. Then install them on the opposite side to reverse the wear pattern on the bristles. This greatly extends brush life, while improving scrubber performance.

4. **Brush pressure.** You can vary the pressure on Model 40 with the dash board button. Use as little pressure as will do the job. Excessive pressure will shorten the machine's run time on a battery charge, can shorten the life of your brushes, and could even damage some floors.
5. **Chemical Residence Time on the Floor.** Scrubbing slowly may improve the scrubbing job you do. By scrubbing slowly, the brushes stay longer over each square yard of surface, and so scrub more, and the chemical stays longer on the floor before being picked up by the squeegee.

For especially bad spots, you can "double-scrub". To double-scrub, leave the vacuum squeegee up and off. Scrub back-and-forth several times until the grit and grime on the floor has been loosened. Then vacuum it and the solution up.

6. **Adjust that Squeegee!** When your machine was new, it scrubbed and picked up perfectly--the best in the business. How's it picking up now? Not so hot? Then you should check the following:
 - A. **Blades in good shape?** The rear blade on the squeegee is especially important. It can be reversed front to back and from top to bottom, and so can be rotated four times. Look at the condition of the rear rubber's leading edge. If still sharp, it should work well for you. If worn flat, it will smear like an old windshield wiper blade. (See squeegee section of this manual for info on how to rotate the blades).
 - B. **Pitch angle?** The rear corners of the back blade of the squeegee must both touch the floor. Otherwise, the squeegee will only pick up in the middle of its path. To adjust, turn the knob. (See Squeegee Section of this manual).
 - C. **All Clear?** Scrubbers pick up strange stuff, and lots of it. Is your recovery tank cleaned out? Is the path clear inside the squeegee? In the hose? In the inlet to the tank? Remove the vac motors and check the foam filters under them.
7. **STILL NEED HELP? Please call your local dealer. If you have forgotten his name, please call the Factory at 800 634-4060 to reestablish contact with him.**

MAINTAINING YOUR MACHINE

DAILY PRE-CHECK AND INSPECTION

Before each shift (every eight hours of operation), It is the operator's responsibility to carry out the following checks and inspections before beginning operation of the sweeper:

- * **WARNING DEVICES:** Battery condition gauge. Green "ignition-on" light.
And on units so equipped: backup alarm, horn, rotating beacon, headlight.
- * **BATTERIES:** Visually inspect connections. Look for spills & Wipe Them Up. Use baking soda to neutralize spilled acid.
- * **AUTOMATIC PARKING BRAKE:** This machine has "dynamic braking" which slows the machine until it stops. After it stops, a separate parking brake is set by a spring. This parking brake will automatically set, as well, if there is a power failure.

If you can push machine when it is stopped, the parking brake needs adjustment.
If machine lacks pep, and appears to drag, the parking brake may not be releasing. Check manual for inspection procedure, in this case.

If brake fails to release, automatic release mechanism may have an object jammed in it, or may need repair or adjustment. A dragging brake will result in :
 - A. Damage to brake linings.
 - B. Possible damage to traction motor.
- * **STEERING:** Should have no play, and should turn freely without binding.
- * **CLEAN THE RECOVERY TANK.** Drain it completely every day through the drain hose. Hose out and check condition by looking in the flush-out door on top of the tank. If still full of debris, open the cleanout door (at back of the tank) and clean out the floor of the tank.
- * **CLEAN OFF MACHINE:** If dusty, clean machine with compressed air. To maintain paint, use S.C. Johnson's "Pledge" furniture polish and soft cloth, or an equivalent product.
We do not recommend washing, and especially do not recommend pressure washing this machine as misdirected water could damage electricals.

IF THE MACHINE IS IN NEED OF REPAIR OR IN ANY WAY UNSAFE OR CONTRIBUTES TO AN UNSAFE CONDITION, THE MATTER MUST BE REPORTED IMMEDIATELY TO THE SHIFT SUPERVISOR. DO NOT OPERATE THE MACHINE UNTIL IT IS RESTORED TO PROPER OPERATING CONDITION.

MONTHLY INSPECTION

In addition to shift inspections, perform the following each month:

- * Check battery charge with an external volt meter. If "fully-charged" battery does not attain at least 24 volts, further investigation is required.
- * Grease front wheel; two "zerk" fittings are provided for this.

DAILY CLEAN-UP

After you're done for the day, please lift the brush head with the dashboard switch, lift the squeegee with the vacuum switch, and push the solution control button all the way down. Drive to your service area and stop.

Before you turn off the key, lower the brush head a half inch from the top. Turn off and remove the key. Lift the side wiper on one side of the machine. While lifting it, open the side door. Once the door opens, then turn the brush on that side until you see the "scissors handles" control. Push the scissors together to release the brush.

Remove the drain hose from its bracket. Carefully lower the hose to the drain. **WATCH OUT--MOVE TOO FAST AND YOU'LL GET WET.** You can squeeze the hose shut with your hand until you position it where you want it.

Drain the tank. Open the door on top of the recovery tank (the back one), and using cold water and a spray nozzle, wash the dirt that has accumulated in the tank out toward the drain hose. If you succeed in cleaning the tank well enough, you do not need to use the cleanout door.

If the machine is still full of debris, open the cleanout door after the tank has drained its water. You can use the tool provided with the machine to help scoop out debris. Rinse again with the hose if necessary.

Rinse off the brushes. Remove any debris that may have gotten caught in them. Remember to reverse the brushes daily.

Rinse squeegee with water. Wipe off the edges of the blades with a cloth.

If machine needs washing, use a regular garden hose to wash it, not a pressure washer. Do not spray the dashboard or the batteries. Wipe dry with a soft towel. Do not use paper towels or dirty shop towels, or you will scratch the powder paint finish. We recommend you wipe down your machine each day with a dry cloth and a liberal dose of Johnson Wax's **Pledge** furniture wax. This will keep the "paint", (it's really a baked-on plastic coating that encases the steel structure to prevent rust), lustrous and scratch free for years.

Store the machine in a clean dry place.

To recharge batteries, leave the box open, and unplug the machine from the batteries. Plug the red connector from the batteries into the charger provided with the machine. **Use only the charger provided or an equivalent "smart" charger. Do not use a "dial type".**

SQUEEGEE AND VAC SYSTEM

The vacuumized squeegee drags on the floor constantly while in use, and so is the most sensitive part of an automatic scrubber. Lucky for you, Factory Cat Model 40's squeegee and vacuum system are simple, straight-forward and easy to access.

GENERAL MAINTENANCE: Squeegees pick up all kinds of stuff. When the rubber blades are dirty, they streak. If you have a wad of newspaper stuck in the squeegee, it may not work at all. If the squeegee isn't performing right, raise the squeegee (while going forward slowly), and drop it on the floor again. This may dislodge whatever is stuck in it, and may help clean off the blade. Still streaking? Inspect the blade. If it is coated with tar or some other industrial goo, you may have to wash it off or replace it.

ADJUSTMENT: Model 40's squeegee is self-adjusting except for the "pitch" the angle the squeegee's blades make with the floor. This pitch adjustment is very sensitive. One eighth turn left or right can make a difference. Your machine's squeegee should be adjusted to your floor at delivery. Thereafter, readjustment is seldom necessary. To adjust properly,:

Loosen the two locknuts at back of squeegee adjusting screw.

Drop squeegee to floor.

With vacuum running, drive machine forward so rubber of squeegee flares out.

Turn the Adjustment Knob until the rear squeegee blade touches the floor evenly across the entire width. At this point the wheels at rear should just start to touch floor.

Test results on floor.

From this point, adjust squeegee knob clockwise to improve performance on squeegee edges, and counterclockwise to improve performance in middle.

If squeegee is properly adjusted from a pickup standpoint, but your squeegee fishtails left to right, try changing the squeegee's trailing wheels. Normally these are changed when blade rubbers are changed.

REVERSING OR CHANGING THE BLADES: Bad blades don't work. Inspect the blade edge where it touches the floor. Is it still sharp, or is it blunt and frayed. If worn, you'll have to change it. Both blades are important. You can reposition Model 40's squeegee blades four times. The back one is easy: just undo the buckle on the steel strap, and remove the two wing nuts. Turn the blade upside down for the first change out. For the second one, flip it around front-to-back. For the third change out, turn it upside down again. For the front blade, there are some nuts to undo. Better to remove the squeegee from the machine for this one. **When the time comes to replace the blades, order Factory Cat's "Blade Kit" for Model 40. This includes the two rear blades, one front blade, and two replacement wheels for the back of the squeegee.**

Squeegees are normally supplied with **Gum Rubber**, a tan-colored material. If your application requires that the machine run in oil, you might want to try **Neoprene** seals instead. Neoprene does not wipe as well as Gum, to our experience, but it is much more oil resistant than Gum. For speciality applications, we can supply **Linatex** rubber seals. Linatex is super abrasion-resistant, and squeegees well too, but is about as sensitive as gum rubber to oil.

SQUEEGEE AND VAC SYSTEM (Continued)

Vac Motors, Filter & Compartment. After cleaning the tank, lift the lid that houses the twin vac motors. You can unplug this lid if you want at the connector located inside the housing.

Check the filter screen by lifting it out of the housing and wash it off. A dirty screen will cause the ball to lift, turning off air flow before the tank is full.

Be sure the "pingpong" ball, located in the filter screen, is in position. This ball rises in response to solution level or foam in the tank, and shuts off air flow to the vac motors. If this ball is missing, you could damage the vac motors. Be sure the gaskets on either side of the filter are in good shape--or air leaks will rob your machine of vac pickup performance.

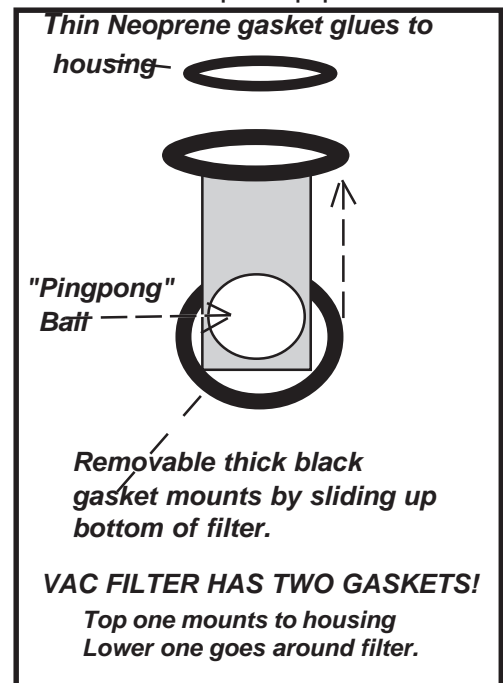
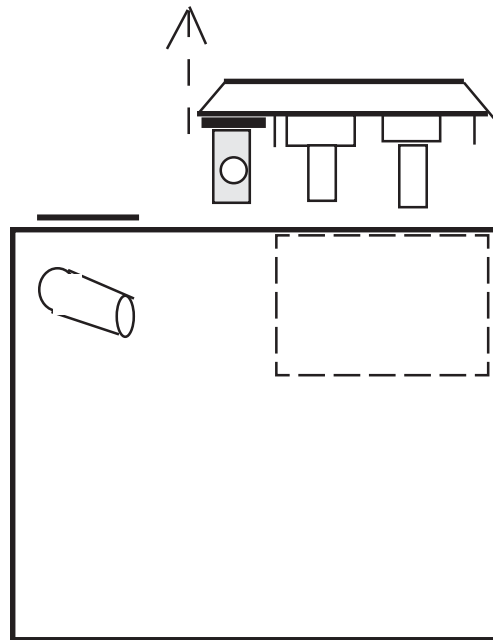

In returning the "lid" to the vac motor compartment, be sure the flanges are placed inside the box as shown:

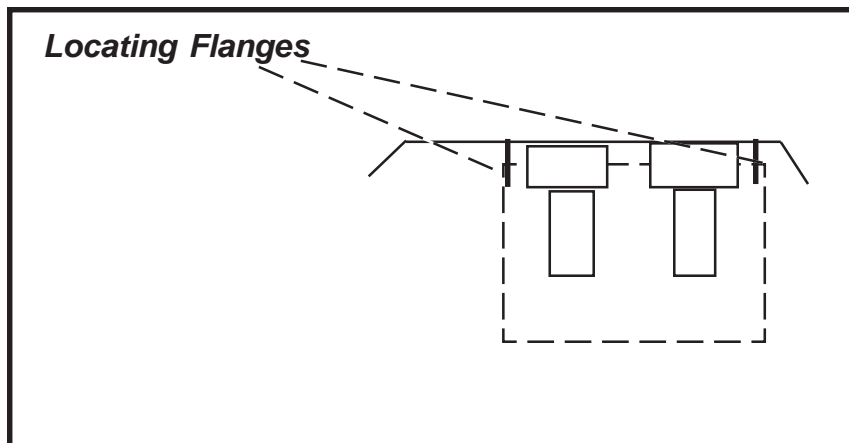

GENERAL MACHINE MAINTENANCE

BATTERIES: The highest maintenance item on your machine will be its storage batteries. Please read the "About Batteries" section of this book.

BRUSHES: Replace the brushes when they stop scrubbing to your standards. Note that choice of the proper brush fiber is very important to good scrubbing. There are several different fibers available. Rotate brushes often (every 8 hours of use).

Fibers include: Polypropylene, Nylon, Tough-Grit, and Light-Grit. Please ask your dealer for his brush recommendation for your application.

We recommend Factory Cat brushes. They are designed specifically for your machine. Their fiber is high quality and long-lasting, and use plastic cores that are tougher than the wood cores some "will-fit" makers provide. Finally, we believe you will find them reasonably priced.

REMOVING AND REPLACING DISK BRUSHES

1. Raise or Lower the Brushhead (using the dashboard control) until it is about halfway between the floor and the top position.
2. Release the latch on the side panel. (Push the bottom of the latch and the top portion springs out.)
3. Lift the Wiper blade. It is hooked to the brush head.
4. Swing the door open.
5. Turn the brush until you see the "scissors" on top of the brushhead.
6. Push the "scissors" together, and brush will drop to floor.
7. To replace brushes, hold the brush by its center.

Push the brush into position onto its "driver" under the brushhead. The scissors will automatically latch.

(If the brush is hard to push on, you can hold the scissors "open" to make pushing the brush on easier).

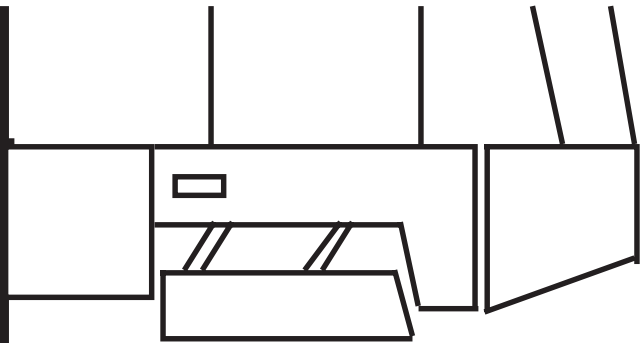

TO OPEN THE BRUSH ACCESS DOORS

Be sure the brush-head is mid-point off the floor.

Then open the latch on the door.

Then raise the Wiper off the floor so it unhooks from the scrubhead.

Then open the door.

Looking Down on the Brush Head

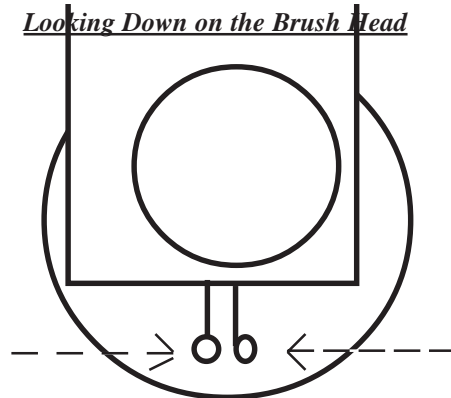

Push "Scissors" Together to Release

REMOVING DISK BRUSHES:

Turn the brush until you see the "scissors handles".

Then push the scissors handles together, and brush will fall to floor.

CYLINDRICAL BRUSH SYSTEM MAINTENANCE

DAILY:

1. Empty and wash out the dirt hopper every day.
2. If you scrub hard, the brushes will last longer if every day you move the front brush to the back and the back brush to the front.
This brush rotation is not appropriate if you are using a combination of brushes, such as green grit in front and grey in the back.

To remove brushes remove door on righthand side of scrubhead (Please see also Page 16)

WEEKLY:

1. Measure brush length. Bristle must be 1/2" long or longer. (New brush fiber is one inch long). Replace brushes as needed.

MONTHLY:

1. Remove black side cover on lefthand side of cylindrical unit.
2. Inspect chain.
Chain compartment is about half filled with one pound of special hi-temperature teflon grease. The chain is automatically adjusted for wear with an automatic chain tensioner. When tensioner runs out of spring tension replace chain and grease.

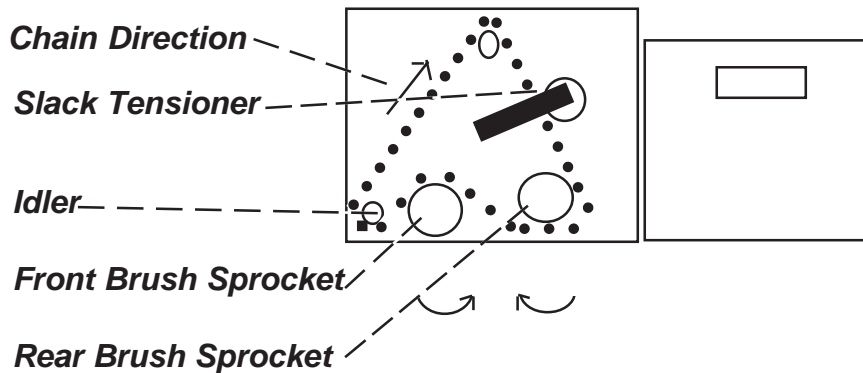

| | |
|----------------------------|----------------|
| Chain: | Part No. 5-830 |
| Special Grease (1 lb can): | Part No 5-796 |

ABOUT BATTERIES:

We do not recommend use of anything but deep-cycle batteries, made to run a long time between recharging. Automotive batteries, designed to be recharged (by the car's alternator) right after short use, will give poor service.

Your unit came with a "smart" electronic external charger. If for some reason you use another charger, do not use a "dumb" or dial-type charger. Do not use an external charger of any type without first disconnecting the batteries from the Central Command unit!

Always leave the battery box open when recharging. Otherwise hydrogen gas could build up inside the battery box.

GENERAL RULES FOR BATTERY CARE:

1. KEEP THE BATTERY CLEAN. Dirt on the battery transmits electricity and can cause quicker discharge.
2. KEEP THE BATTERY WATER AT THE CORRECT LEVEL. The correct level is above the plates-- just to the bottom of the "ring" found inside each of the six cell caps.

A low water level can ruin the battery very quickly. Water should always cover the plates inside the battery. (You see the tops of them when you remove the cap). Many batteries have "rings" that are visible inside the cell holes. In these batteries, fill to ring. We recommend you use only distilled water. The minerals in ordinary water can coat the lead plates, shortening battery life.

3. CHARGE THE BATTERY WITH THE CAPS IN PLACE. Do not remove the caps for a normal charge. These caps include proper venting, and will keep the charging process from projecting a thin layer of acid on surrounding machine parts.

EXCEPTION: Quick-Charging. Follow the instructions that came with the quick charger. You may be asked to remove the battery caps. Note that quick-charging is not a good idea; it can lower battery life.

4. ACID! Batteries contain corrosive sulfuric acid. As mentioned above, leave the vented caps in place when charging, so acid will not bubble out of the battery. Take care that acid does not fall on the steel surfaces of the machine; eventually it will cause the machine to rust.

Treat acid spills with water to dilute the acid. To clean up: use solution of water and baking soda, applied with a small brush. Keep using the solution until the fizzing stops. This will neutralize the acid.

5. MAKE SURE CONNECTIONS TO THE BATTERY ARE TIGHT. Loose connections will cause arcing, which will eat into and destroy the battery terminals.
6. WATCH THE GREASE. Never put grease on the **inside** of the connector. The grease will cause arcing and deterioration of the connector. You can put grease on the **outside** of the terminal after it is mounted to the battery.
7. DO NOT HAMMER ON THE BATTERY OR ITS CONNECTORS: Batteries are heavy but fragile. Hammering on the posts on the battery can break the connectors inside. Use a puller to remove connectors, not a hammer or a screwdriver.

TROUBLESHOOTING GUIDE

CENTRAL COMMAND

Model 40 Rider Scrubber is very simple mechanically. This simplicity is possible in large part, because of the sophisticated "Central Command" control unit. This unit, which forms the righthand control panel, directly controls the brushes, the recovery vacuum blowers, the traction motor, and the dynamic and parking brakes. To conserve battery reserve power, Central Command turns motors off when they are not needed, and controls them so as to minimize strain and maximize component life.

Do not attempt to service the Central Command unit during the warranty period without written permission of the Factory or of your Authorized Factory Cat Dealer. Doing so will void the warranty.

In general, if a fault is traced to the Central Command module, the entire module will be exchanged under warranty with a Factory-tested replacement.

After warranty expiration, you may wish to repair the Central Command module yourself. We strongly recommend that you obtain our "Central Command Testing and Repair Manual" before doing this, however. In North America, please call 1-800-634-4060 to obtain a copy.

You can also send in your Central Command unit for repair or exchange at the Factory. To do this, call your Authorized Factory Cat dealer.

Central Commands can be removed within a few minutes from the machine. To do this, you first disconnect the batteries from the Central Command (unplug the Red 175 plug inside the battery box), then disconnect the quick-connect cables that are found under the Central Command, in the wire channel, under the frame, accessed through the righthand brush door.

You must also disconnect the flow control's cable from the flow valve (in brush head area, behind brush head).

**When Servicing Central Command,
Always Disconnect the Battery Cable
(Item 4) First, and Reconnect It Last**

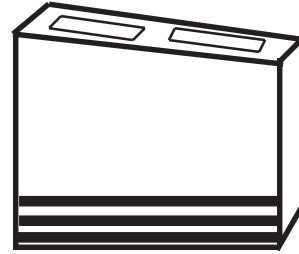

Wiring Connections for Central Command:

In replacing Central command, the installer will have to match harnesses. To simplify troubleshooting, the system uses 10 independent number-coded harnesses, each with color-coded wires. These harnesses are as follows:

| <u>CODE:</u> | <u>FUNCTION & WIRES:</u> |
|--------------|-------------------------------------------------------------------------------------------------------------------------------------------------------------------------------------------|
| 1 | To Traction Motor Red 50 Connector. 6 Gauge cables. |
| 2 | To Scrub Motors Red 50 Connector. 6 Gauge cables. |
| 3 | To Vacuum Motors Grey 50 connectors. 6 Ga. Cables. |
| 4 | From Batteries Red 175 Connector, large (I/O) cables. |
| 5 | Auxiliary Harness 4 Thin Wires Together; 4 prong "Molex" Connector. This is for accessories. Your machine may not use this harness. Wire colors are blue, red, black and white. |
| 6 | Foot Pedal Harness 3 Wires with black outer insulation; 3 prong Molex. Colors, green, white and black. |
| 7 | Brake Solenoid and Cooling Motor Harness 4-Pin Molex. Colors are blue, black, red, black. |
| 8 | Solution Valve & Overflow Switch Harness. Four-pin Molex with Green, Yellow, black and orange wires. |
| 9 | Squeegee Harness: 4-pin Molex. Colors: pink, orange, green and white. |
| 10 | Scrub Head Actuator Harness. Four pin molex, wires colored yellow, blue, white, pink. |

ACCESS TO EXTERNAL WIRE CONNECTIONS

If a wiring fault occurs, chances are greater it is in the wiring leading to the Central Command unit than in the Central Command itself.

To make your Central Command unit easy to service, we have made all harnesses that lead to the Central Command so they are easy to disconnect.

But scrubbers do their work in dirt and water and corrosive chemicals, all of which are harmful to electrical connections.

These connections are therefore housed in a "channel" found directly under the Central Command unit, and protected by a frame rail and the floor on two sides, and by a cover on the other two sides.

Should you need to, you can access the connections in the channel by removing the cover.

Be careful when reinstalling this cover that you do not cut any wires. Each harness inside is numbered as shown on the previous page.

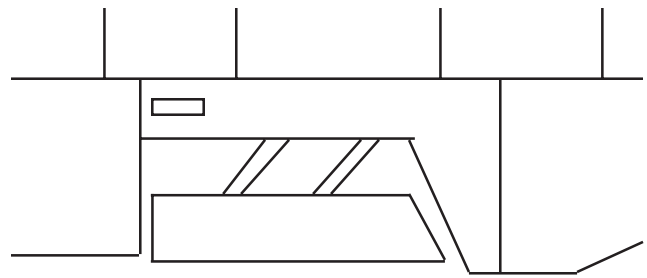

**To Access the Wire Trough
Open the Right-Hand Brush Access Door**

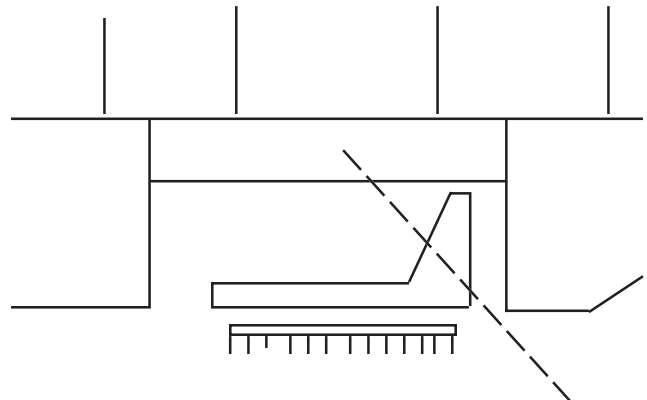

**Wire Connections are Behind This
Frame Section and Are Accessed
From Behind**

(Cut-Away View From Front)

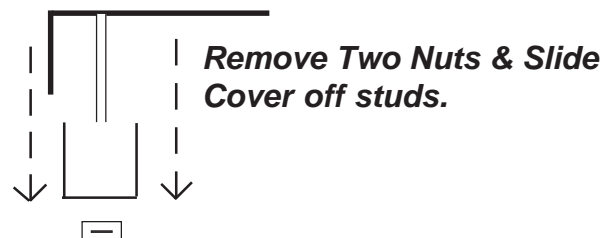
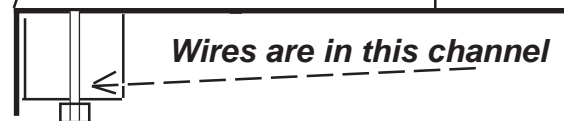

MODEL 40: Troubleshooting Guide

GENERAL: Model 40 is mechanically simple, but has a sophisticated "brain" to operate it in the form of the Central Command unit. This unit should be as reliable as the microprocessor for a modern automobile.

In most cases, the big question is to determine if the problem is :

- A. Mechanical, or
- B. Electrical, but in the wires or devices.
- C. Electrical, inside the Central Command.

If your problem is not easily solvable, please call us at **1-800-634-4060**. We can put you in touch with your local dealer, who can provide you with repair service or perhaps just telephone advice.

During the Warranty Period, if the problem is inside the Central Command unit, the entire unit must be replaced. After the Warranty Period, you may choose to repair the Central Command unit, and spare parts are available for it. **Please call us at 1-800-634-4060** for a copy of the "Central Command Testing and Repair Manual" for information pertaining to this device.

ELECTRICAL PROBLEMS

1. Key On, But Nothing Happens: No Noise, No Action--Nothing!

- A. Operator is familiar with machine and knows that you have to step on the foot pedal before anything will operate.
- B. Battery Set is properly connected, and puts out at least 20 Volts.

NOTE: Central Command is extremely fussy about wire connections from the battery into it. A half-loose connection is sensed by the electronics and will not allow the machine to operate. Check and double check the battery connections!

- C. All Following Wires are Connected, Unbroken and Tight.
 - 1. Wires From Central Command to Traction Motor. (Inside wire trough)
 - 2. Battery Cables To Central Command. (Inside battery box).
 - 3. Foot Pedal Three Wire Cable to Central Command. (Inside wire trough).
- D. Unplug the Battery Pack (Red 175 connector inside battery box). Then, carefully remove Rear Control Panel from Central Command. Reconnect battery box. Check for voltage to and from the keyswitch.

MODEL 40: Troubleshooting Guide

For each symptom, run through steps in order shown.

Electrical Problems

2. Key On Gets "Click", and Green Light Comes On, But Stepping on Pedal gets No Action.

- A. Be sure pedal wiring is tight and unbroken. This is the three-wire set going into the Central Command. The wire is integral with the foot pedal. (Connection is in the wire channel).

Note that the pedal will need periodic cleaning in some work environments. To do this, use "**Contact Cleaner**" only, the kind used to clean radio and TV tuners. Take apart the pedal, remove the foam rubber "dust cover" on units so equipped, and spray some carefully down the shaft of the rheostat inside the pedal. Replace dust cover. **Cleaning almost always solves a pedal problem.**

If you think the pedal is defective, please call your dealer for the test procedure to verify its condition.

3. Machine Runs Fine in Forward, But Cannot Be Shifted Into Reverse.

- A. Remove Rear Control Panel from Central Command and Check Connection to Forward-Reverse Switch. This switch receives power from the key switch, and sends it back to Central Command's microprocessor. No power = forward; power on = reverse.
- B. Check Switch Output.
- C. Verify reverse wire is plugged into Curtis control. This 16 pin "Molex" must fit properly into the Curtis'es socket.

4. Traction Motor Overheats or Smells Hot

The traction motor, located in a recess underneath the two tanks, is cooled by an internal fan. A supplemental fan on top of the motor runs whenever the key switch is on. Air is pulled down from the vent holes on top of the recovery tank. The supplemental fan was provided to keep the motor cool if the machine is run in a hot environment (Arizona in Summer) or if hot water is used in the solution tank.

- A. Check that vent passage from top of tank to motor is clear. You can look through the holes. The top of the tank is removable.
- B. Make sure the supplemental cooling fan is running whenever the key is on. It is very quiet, but it is audible in a quiet room. Wiring for the fan passes through the wire trough.

Electrical Problems

5. Traction Circuit Runs Fine, And one or more, but not all of the Following Work Properly: Vacuum Motors; Brush Motors; Parking Brake Release.

Check each defective circuit as follows:

A. Vacuum Motors.

1. **Is the tank full?**
2. **High Solution Tank Shutoff.** There is a shutoff inside the tank so that when the tank is full the motors will not blow solution out the top of the machine. The shutoff uses a mercury float switch. It can be accessed by removing the top of the recovery tank.
3. **MicroSwitches.** The vac motors shut off when the squeegee is raised. The squeegee has two microswitches on it, one of which turns the vac motors on. This one is mounted on the far right rear of the machine, and is operated by the squeegee actuator's movement. Bend the switch's soft metal actuating tab, if necessary.
4. **Wiring from Central Command.** Check continuity between the motors and the Central Command's output to the vac motors. Connection is made inside the Wire Trough. Wires then go through the air duct inside the solution tank to the vac motor housing atop the solution tank.
5. **Call your dealer for advice.**

B. Brush Motors.

Check first to be sure the problem is electrical. It is possible the plastic "clutch plate" on the brush is damaged.

Note too that if there is too much pressure applied to the brushhead on an abrasive or dry surface, the motors will not have enough power to start, and so will kick off the circuit breaker inside Central Command. This will reset itself when power to the brushes is turned off for more than 30 seconds. Just raise the brushhead.

1. **Microswitch.** There is a microswitch on the brushhead that turns the motors on when the brushhead is lowered. It must be checked out. It is situated just above the actuator's "head", and is operated by the movement of the actuator at its front pivot point. Access it through the righthand brush access door.
2. **Grey 50 Connector.** This is between the twin motors and the wire "channel". Sometimes soap deteriorates the plastic, causing a short or leading to a bad connection. Check the connector and replace the plastic if necessary.

Electrical Problems

6. Traction Circuit Runs Fine... (Continued)

- C. **Parking Brake System. Units built AFTER April, 2000.** Parking brake on new units is very powerful. Driving through it will create a pronounced "burned brake" smell and could lead to overheating the traction motor.

Sticking brake would be caused by broken circuit to brake system or by failed six amp automatic circuit breaker located inside the Central Command.

The parking brake system on April, 2000 units is located on the left hand side of the drive motor. It is accessed by removing the machine's left hand rear quarter panel. The unit is mounted on the end of the motor shaft.

A cable release located inside the rear bumper allows brake to be released to push unit. Pull handle and twist.

Parking Brake Solenoid-- Units built BEFORE 4/2000

This solenoid, accessed by removal of the machine's right hand rear side panel, is mounted to the transmission. The transmission's disk brake is spring applied; the solenoid pulls the brake lever against the spring into released position--straight up and down.

The solenoid is a two-speed solenoid, which draws lots of power in "Pull" position to permit movement of the brake arm. Once the solenoid is in "Hold" position, that is, when the shaft is all the way inside the solenoid, the solenoid shifts into "hold" position, which draws little power. The solenoid cannot run in Pull position for more than a few minutes without overheating and damaging itself. It can run in Hold position indefinitely.

The cause of a burned-out solenoid is almost always incorrect adjustment of the brake linkage, so that the solenoid cannot shift into "hold" position.

The solenoid has two wires coming to it--a plus and a minus. Both wires come from Central Command.

1. Check that the wires to the solenoid provide 24 Volt power when the key is on and the pedal is depressed. (To do this, you will need to jack up one of the rear wheels off the ground and remove the right hand rear side panel).
2. If power is OK, check the solenoid.
3. If power is not OK, the problem is most likely in the 6 amp breaker inside the Central Command.

7. Machine Works Well Otherwise, But Insufficient Tractive Power.

- A. Is operator used to the machine? Is it developing its normal power?
- B. Note that if a normally-performing machine has insufficient climbing power or speed, the final drive ratios of the transmission can be changed quickly and easily. See Pages 12 and 30 of this Manual.
- C. Machine has lost most of its power--power loss came on very suddenly.

Batteries are down. Central Command will automatically reduce available power when battery voltage drops below 18 to 20 volts. Recharge Immediately.

Electrical Problems

8 Charger Does Not Charge

The automatic, electronic, console-type charger responds to the battery's condition. It rarely fails.

We note that: If the battery is already charged, the charger will switch on for only a few minutes before stopping the charging cycle.

If the battery is very discharged (below 18 volts at time the charger is turned on) the charger will not "see" that batteries are connected, and will not charge.

The biggest problem with battery chargers is that the batteries are run down so low the automatic charge cycle cannot take place. If this occurs, you can "charge" the battery twice--let it run through its complete cycle two times.

This will work because, every time you turn on the charger, the charge cycle finishes with a three-hour "de-gassing" cycle, in which dissonant wave frequency current is introduced at high voltage (about 29 volts) and low amperage (about 3 Amps). The degassing cycle does not add much "charge" to the battery, and should not be confused with charging. But it is capable of bringing up battery voltage to the 18 volt critical point. Then when you recharge a second time, the charger will give the batteries a real charge (which will take about 14 hours).

Preliminary System Checkouts:

1. Are batteries full of water?
2. Are all connections tight?
3. Check system voltage: Above 18 Volts?
4. Remove harness from batteries. Check voltage. Do all batteries have voltage above 9 volts?
5. Are batteries two years old or newer? If not, then check out with resistance load check.
6. Do you have proper electricity to the charger? Is this power source uninterrupted, or is it shut off accidentally at night when the lights are shut off? This big charger needs a 17 amp, dedicated circuit running at 115 volts. The charger will not run right if the circuit is shared with some other big draw item.

Please Call Your Local Dealer For Further Info. If you have lost contact with your dealer, please call the Factory At 800-634-4060, so that we can reestablish contact between you.

TROUBLESHOOTING GUIDE

Non-Electrical Problems:

THE FOLLOWING APPLIES TO UNITS BUILT
WITH MULTIPLE-SPEED REAR AXLES ONLY
(Units built before April, 2000.)

1. **TRACTION MOTOR RUNS, BUT MACHINE WILL NOT SELF-PROPEL**
Is the problem in the coupling between the transaxle and the motor, between the wheels and the axles, or inside the transaxle?
 - A. Check coupling and alignment: to access it remove left or right side panel. (Coupling usually does not break, but "slam-shifting", repeated shifting under power between forward and reverse, could cause upper piece to move upward, up the motor shaft so the two halves are no longer connected.)
 - B. If coupling is OK, and is securely mounted to both transaxle and motor, then check that both wheels are securely mounted to the axle half shafts. (Is axle turning inside the wheel hub?)
 - C. Be sure transaxle is in gear. Normal gear is third range. To engage it, pull the rear-mounted shift lever all the way out (this is second range), and then push in one click.
 - D. If you are certain the problem is in the transaxle, please call the Factory (1-800-634-4060) for further troubleshooting advice.

SHIFT PATTERN ON TRANSAXLE:

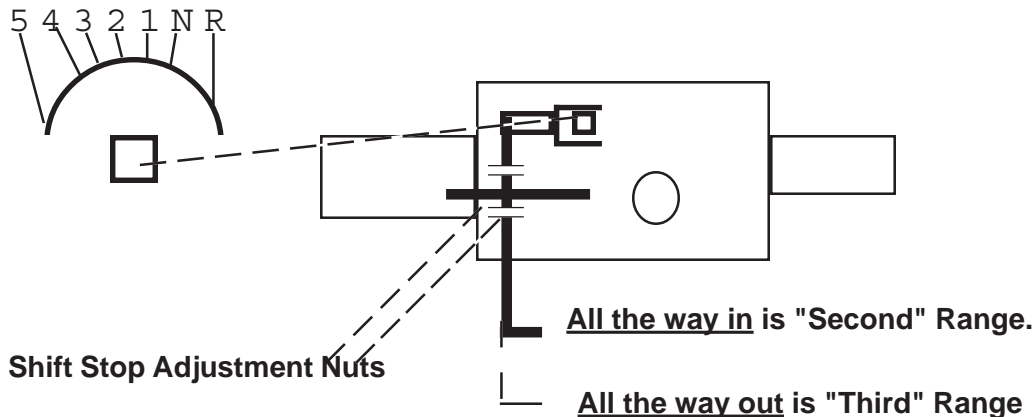

The shift linkage works on a 3/8" square shifting "peg" atop the transaxle. If your machine runs too fast or too slow, it is possible the linkage is out of adjustment.

Model 40 Rider Scrubber

Edition 6

Factory Cat spare parts are sold through Factory Cat Dealers. If you have forgotten your dealer's name, or have moved the machine to a new location, please call us at **1- (800) 634-4060**, **FAX us at 1 (414) 632-3335**, or E-mail us at **fcsupport@factorycat.com** and we will re-establish dealer contact for you.

TO ORDER PARTS:

Please give Machine Serial Number with your order. Normally, ordinary parts orders are shipped out the same day received.

EMERGENCY ORDERS:

Within the Continental United States, Factory Cat can supply any part that weighs under 70 pounds within 3 workdays, not counting weekends or National Holidays.

However, if parts are ordered on an "emergency" basis, this means that R.P.S. will ship them by fastest means, generally by air courier service.

The emergency service is for breakdowns only. Please do not use it to order stock items.

FREIGHT:

Within the United States, normal shipments are shipped by customer choice of shipment method, while emergency shipments are by Factory's choice--normally by fastest means. This means that emergency orders will generally cost the customer more than normal ones.

In both cases, the customer is responsible for payment for freight.

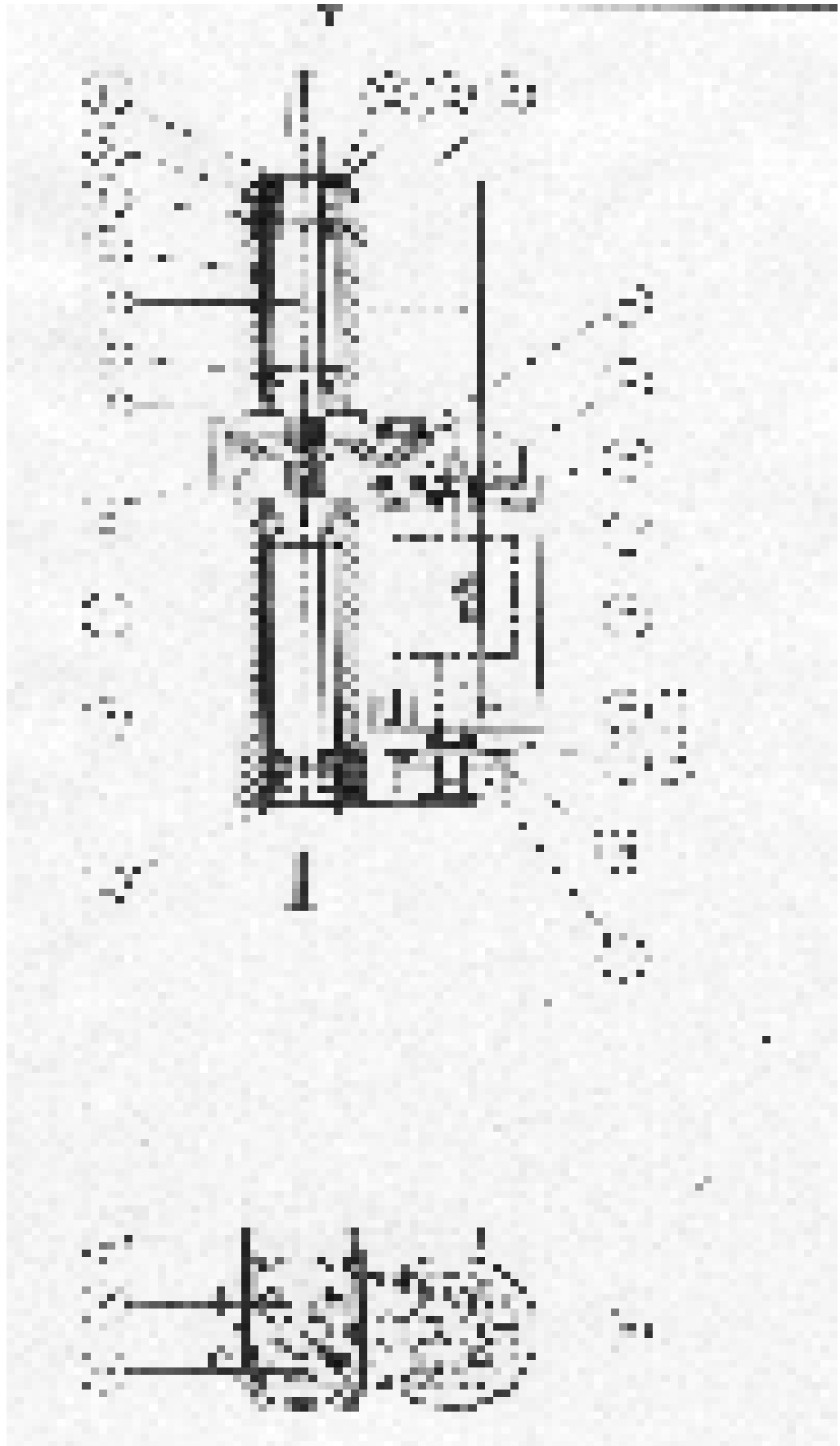

RED

WIRES

PAGE 1

40-CC1

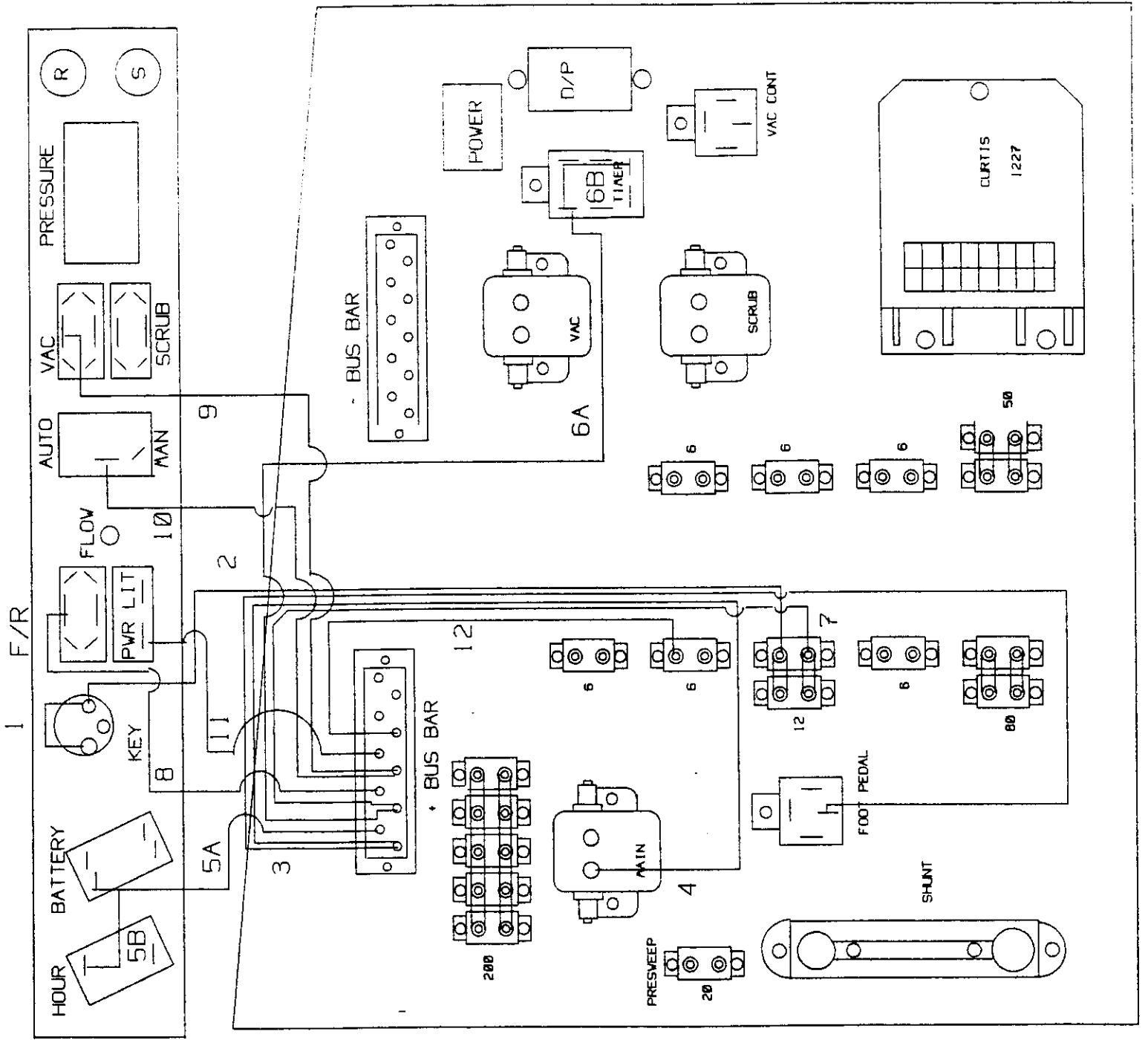

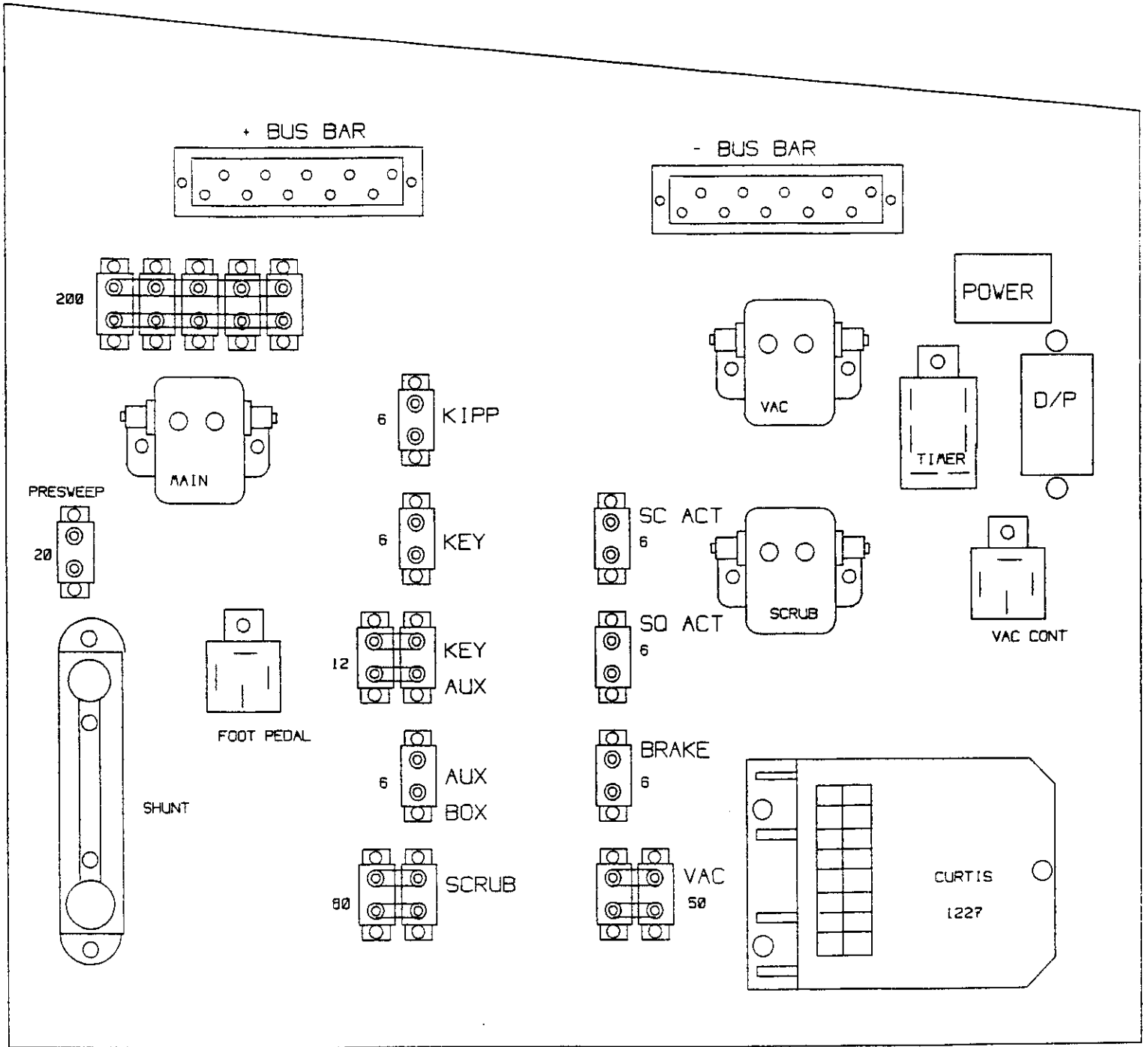
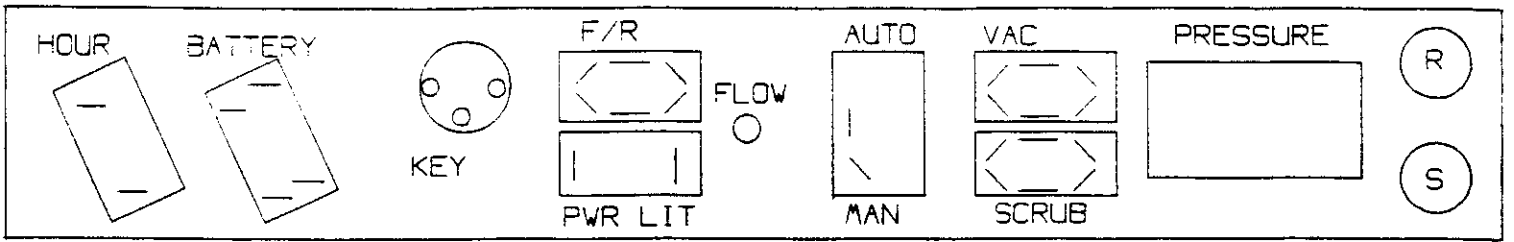

22C

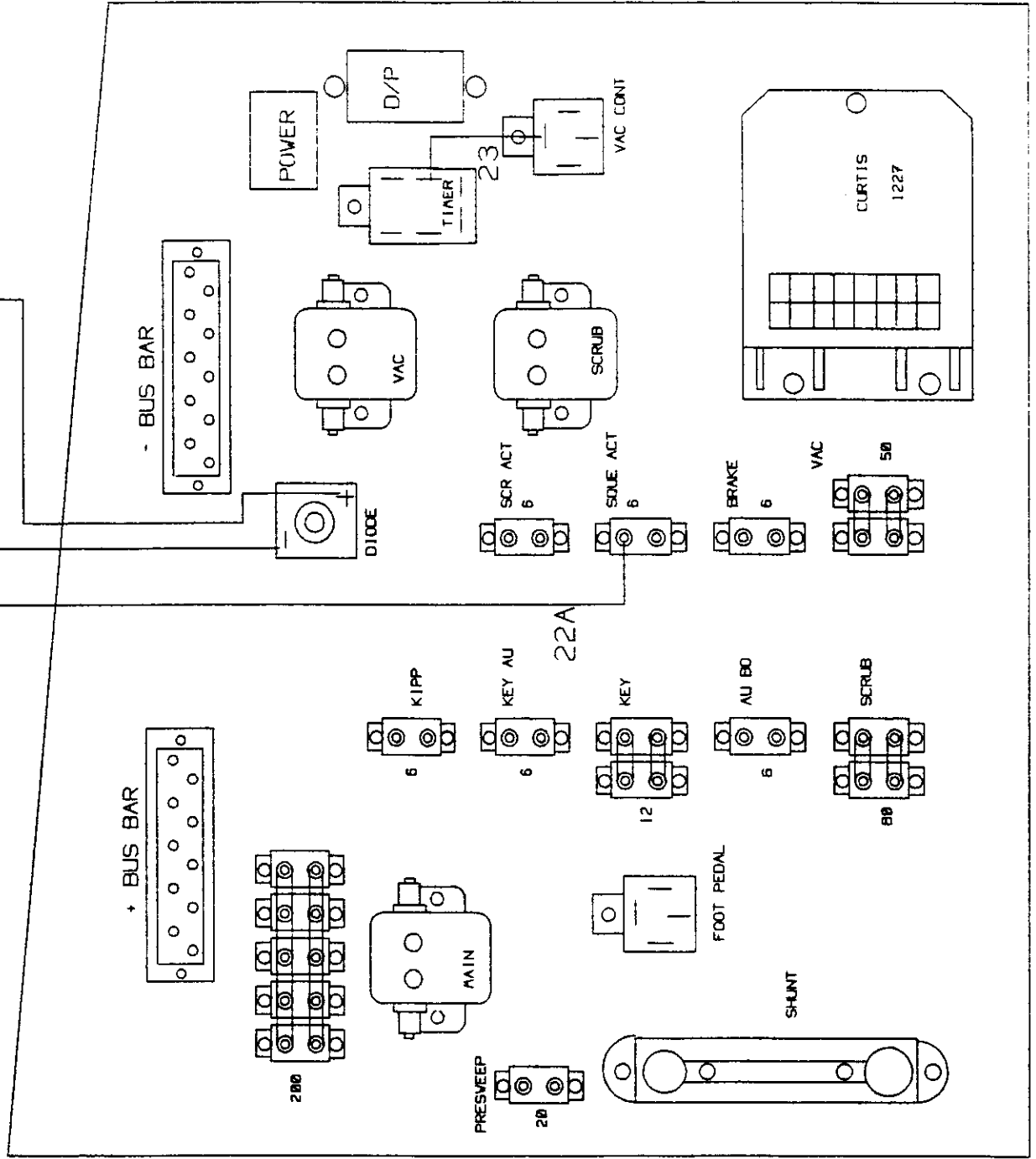
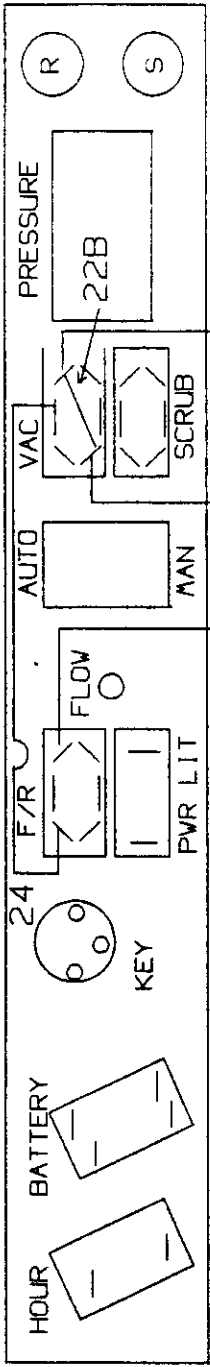

WHITE
WIRES
PAGE 3

40-CC3

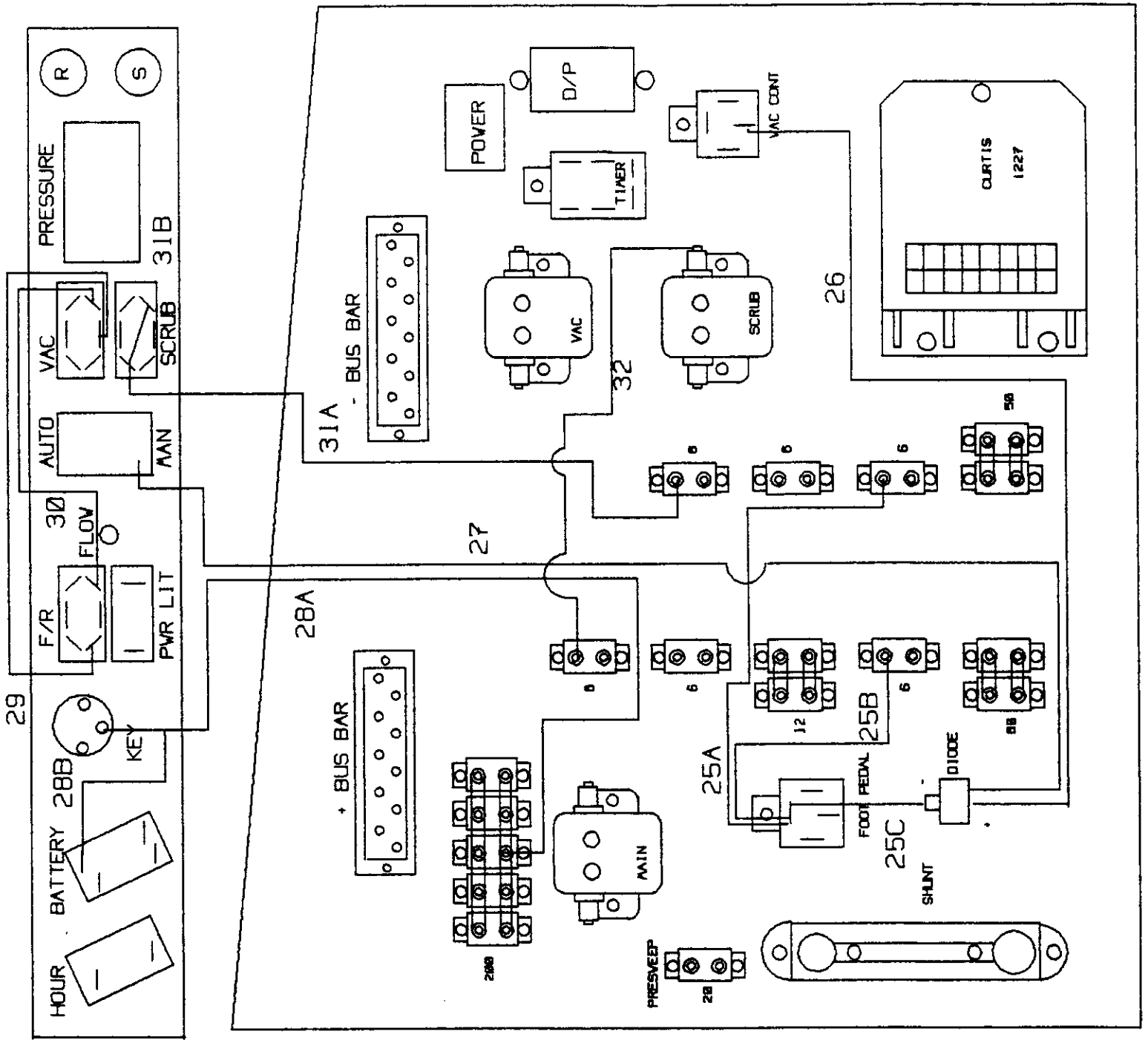

WIRES
PAGE 4

4B-CC4

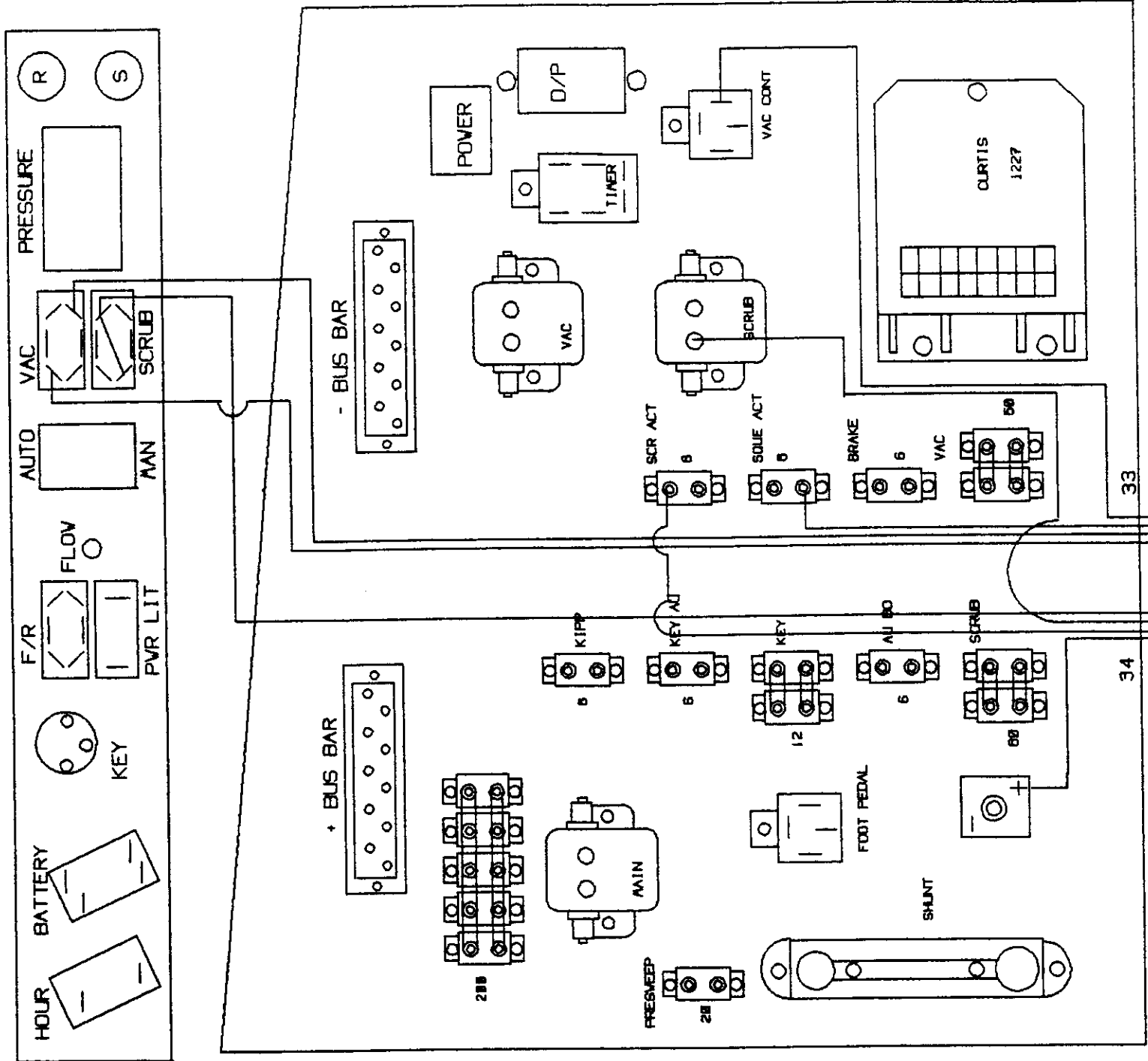

WIRES PAGE 5

40-CC5

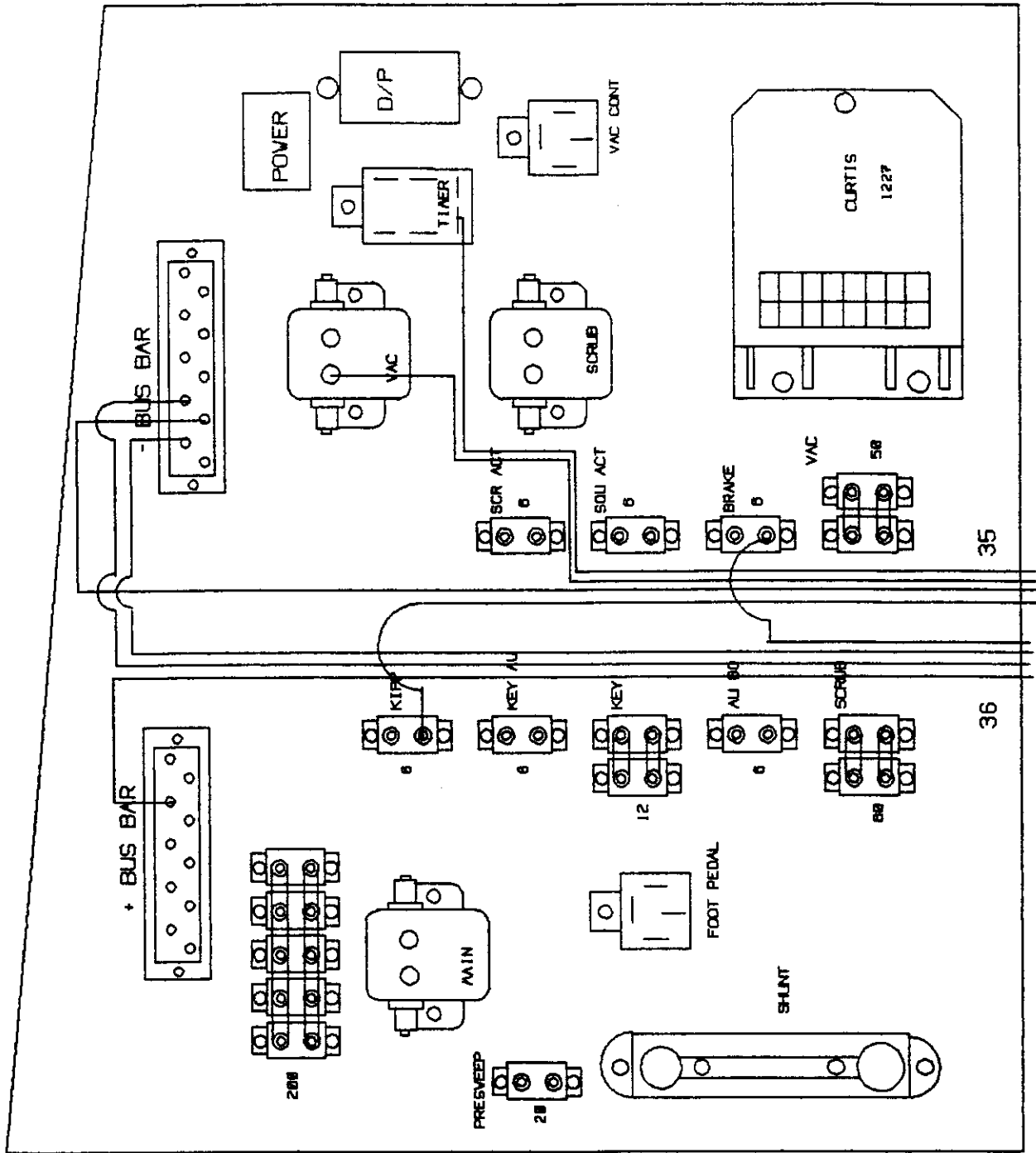
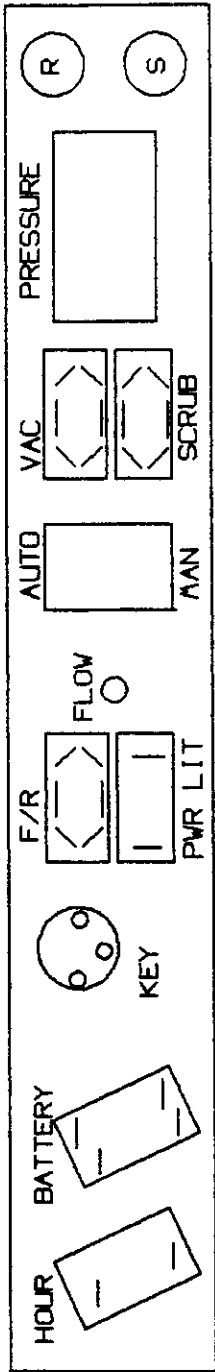

WIRES
PAGE 6

40-CC6

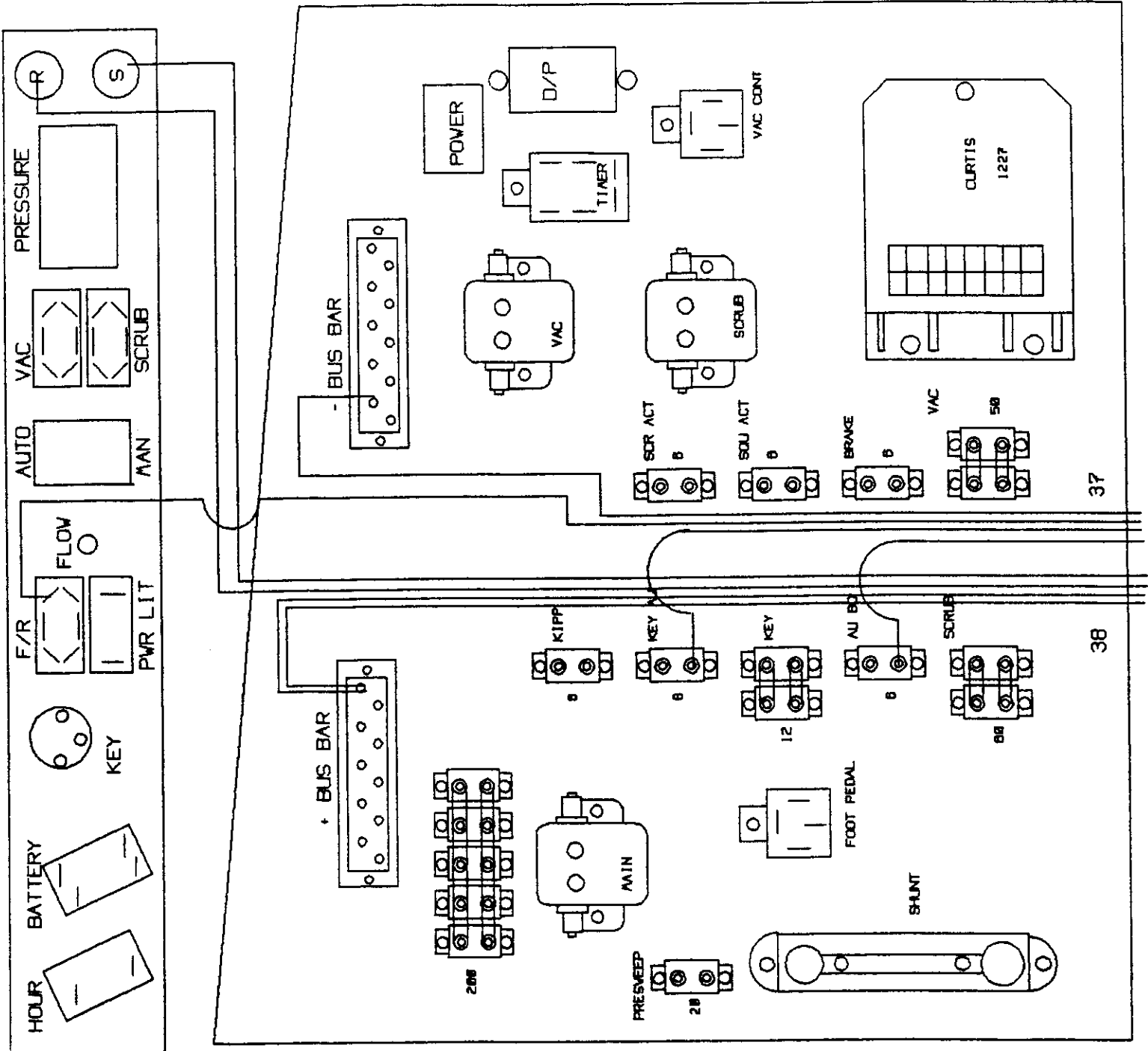

WIRES
PAGE 7

40-CC7

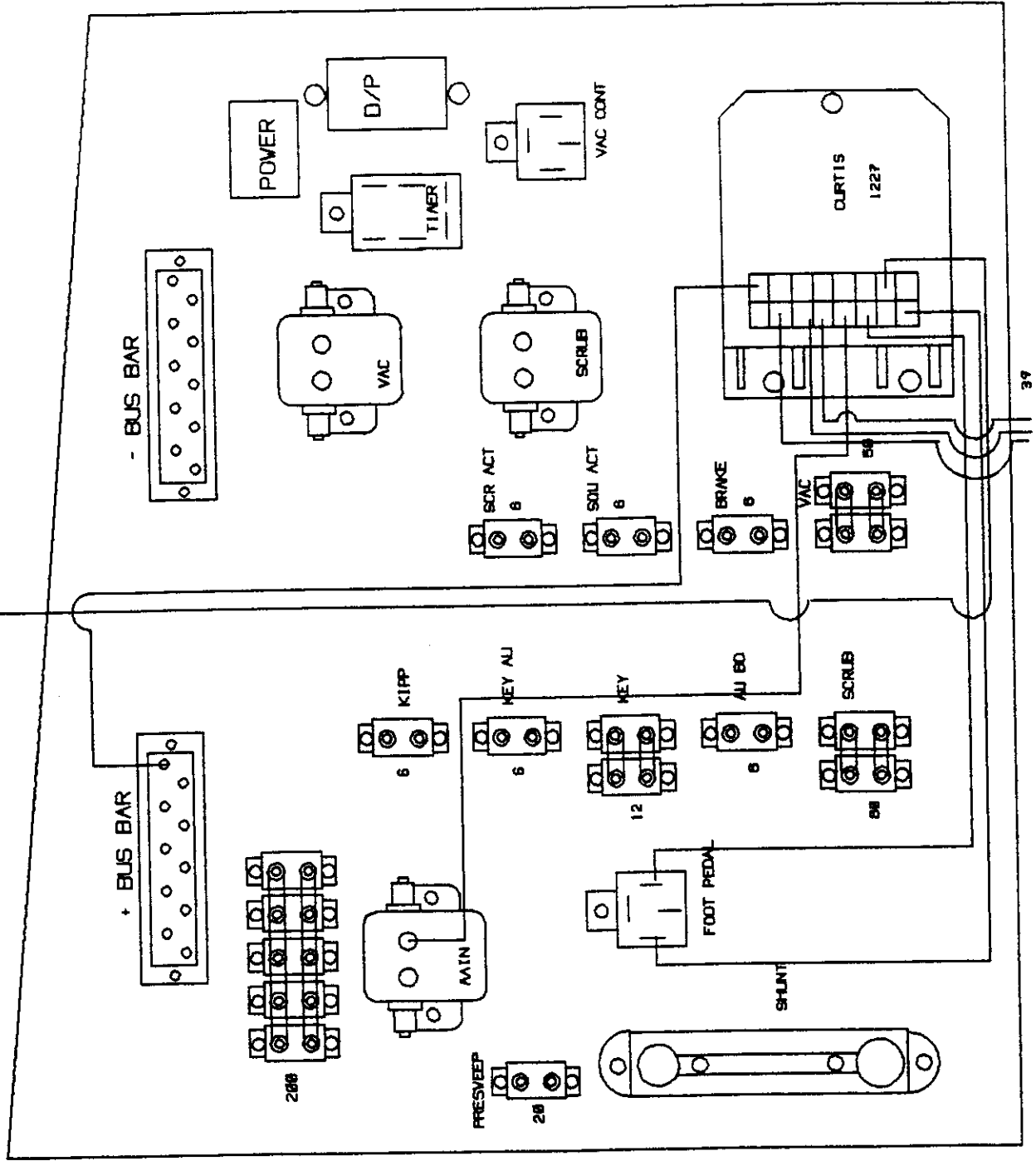
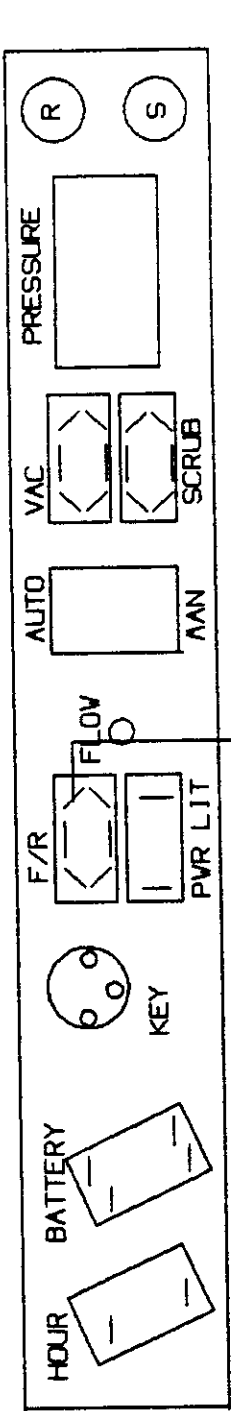

WIRES
PAGE 8

40-CCB

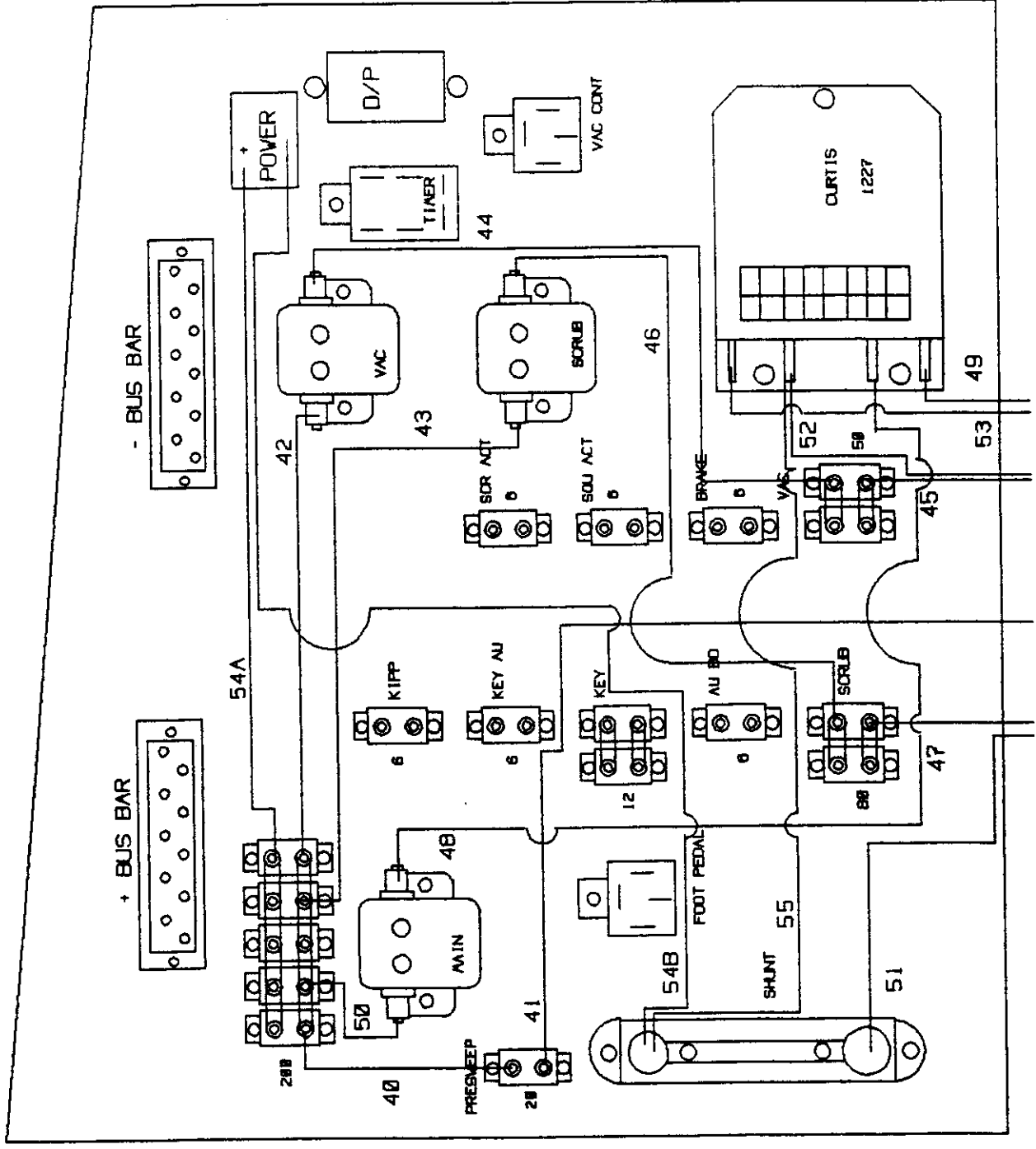
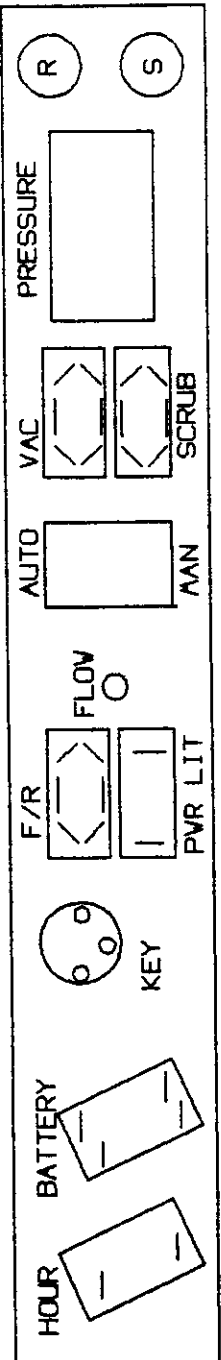

WIRES
 PAGE 9

40-CC9

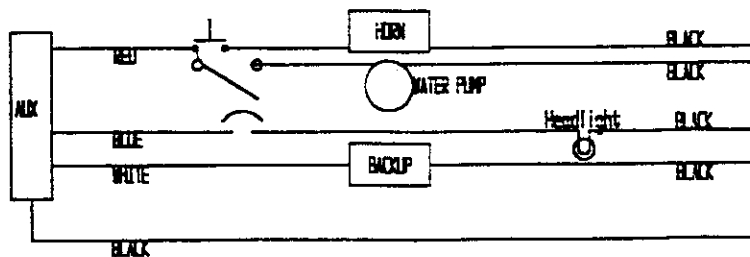
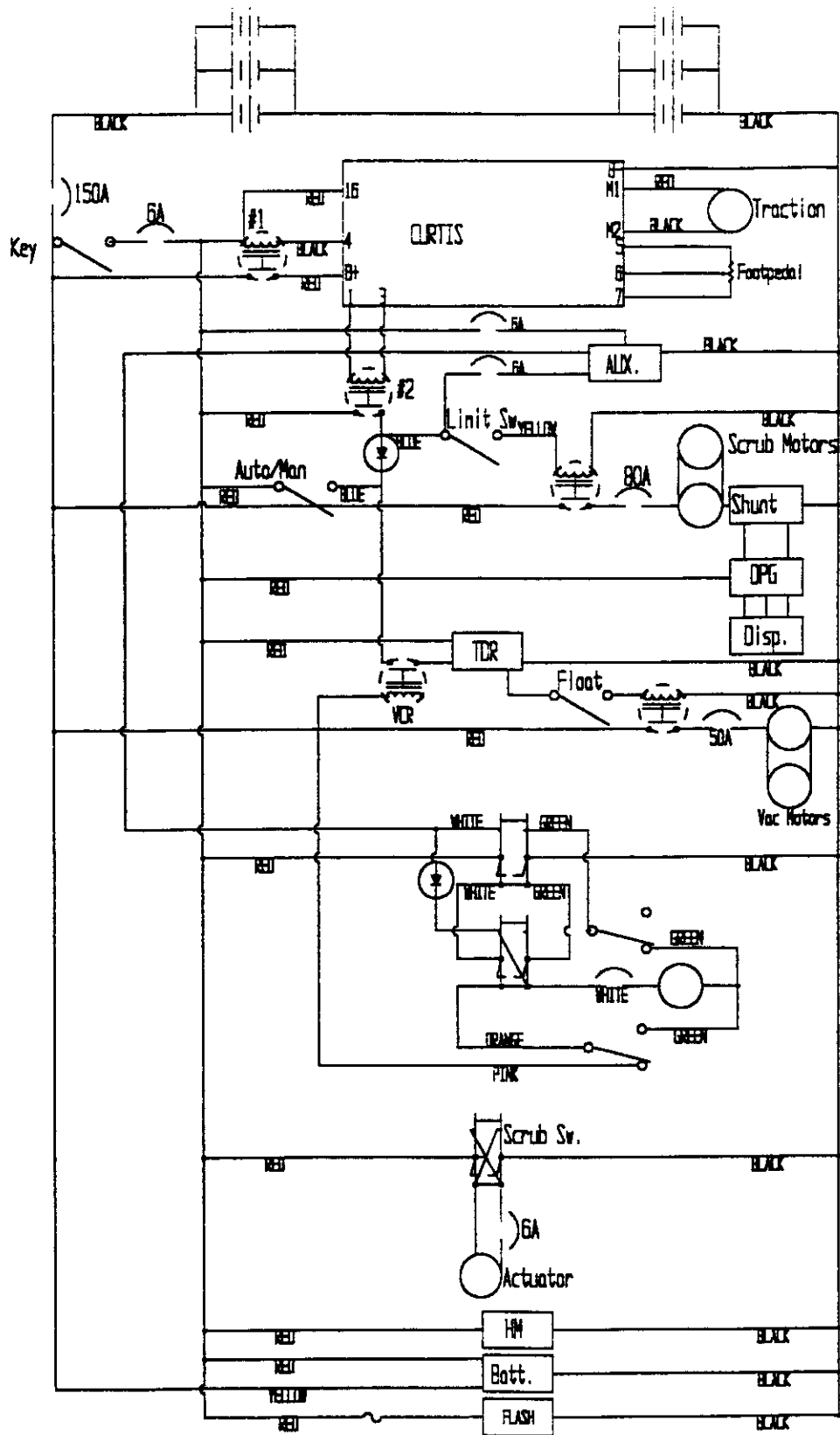

Models 38 & 40
 Broom Lift System Wiring
 on Cylindrical Machines
 With This Option.

40brn lift.dwg

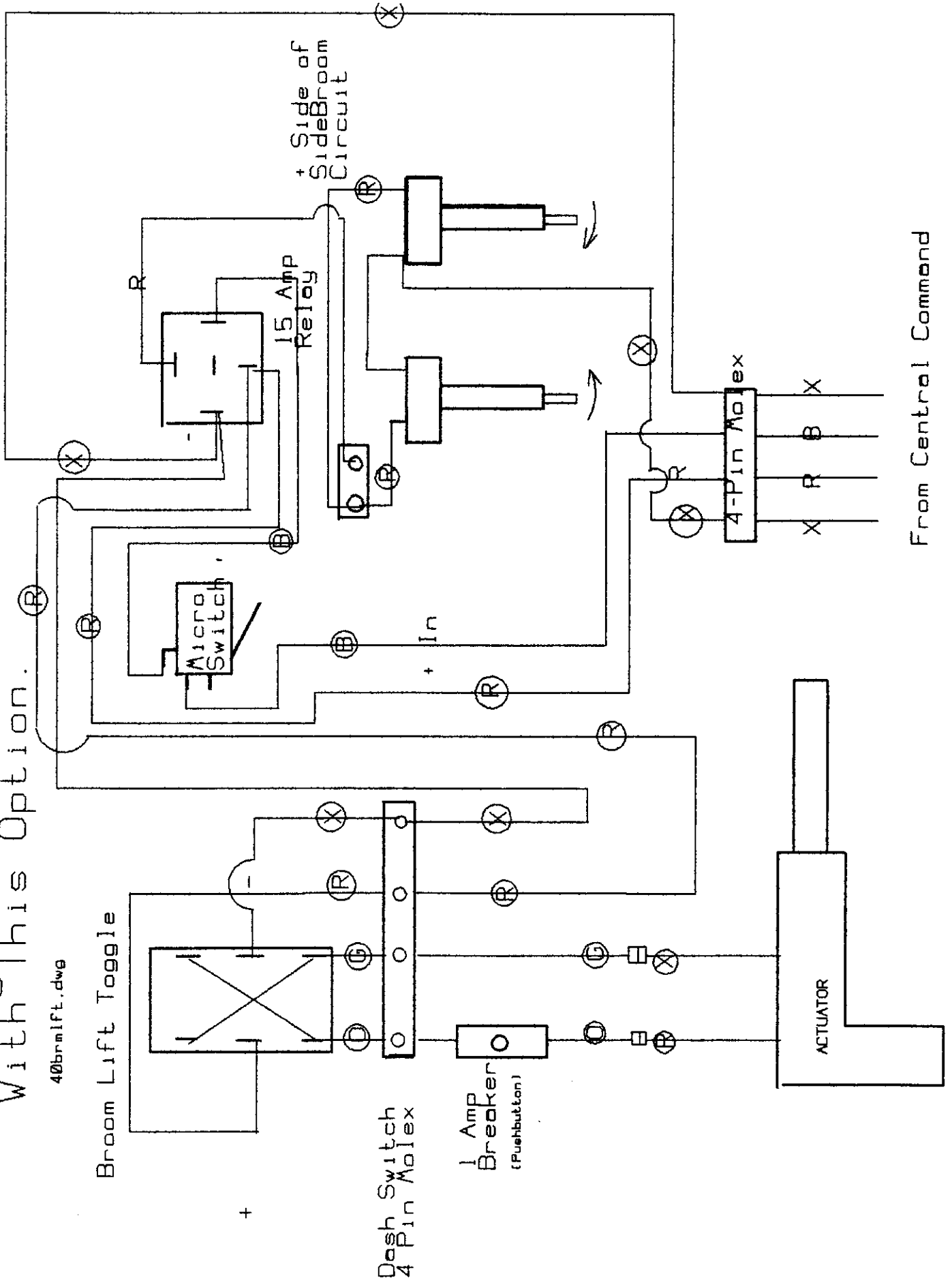

From Central Command

Model 40 Rider Scrubber
Edition 6

Factory Cat spare parts are sold through Factory Cat Dealers. If you have forgotten your dealer's name, or have moved the machine to a new location, please call us at **1-(800) 634-4060**, **FAX us at 1(414) 632-3335**, or E-mail us at **fcsupport@factorycat.com** and we will re-establish dealer contact for you.

TO ORDER PARTS:

Please give Machine Serial Number with your order. Normally, ordinary parts orders are shipped out the same day received.

EMERGENCY ORDERS:

Within the Continental United States, Factory Cat can supply any part that weighs under 70 pounds within 3 workdays, not counting weekends or National Holidays.

However, if parts are ordered on an "emergency" basis, this means that R.P.S. will ship them by fastest means, generally by air courier service.

The emergency service is for breakdowns only. Please do not use it to order stock items.

FREIGHT:

Within the United States, normal shipments are shipped by customer choice of shipment method, while emergency shipments are by Factory's choice--normally by fastest means. This means that emergency orders will generally cost the customer more than normal ones.

In both cases, the customer is responsible for payment for freight.



| GENERAL INDEX FOR PARTS BOOK | | |
|-------------------------------------|----------------------------------------------------|---------------|
| ITEM | PARTS BOOK SECTION | Page # |
| 1 | Wear parts | 3 |
| 2 | Body--Upper | 5 |
| 3 | Body-- Lower | 7 |
| 4 | Electrical | 8 |
| 5 | Central Command | 10 |
| 6 | Scrub Deck, Disk Brush system | 12 |
| 7 | Scrub Deck, Cylindrical Brush System | 14 |
| 8 | Side Broom System (for cylindrical Brush machines) | 18 |
| 9 | Solution System (before HF 40-3100) | 19 |
| 10 | Solution System (After HF 40-3100) | 20 |
| 11 | Recovery System (before HI 40-3803) | 21 |
| 12 | Recovery System (after HI 40-3803) | 23 |
| 13 | Squeegee Lift System | 25 |
| 14 | Squeegee and Squeegee's Suspension | 26 |
| 15 | Steering Column | 27 |
| 16 | Steering Yoke Assembly | 28 |
| 17 | Traction System--Old Style (Before 4/2000) | 29 |
| 18 | Traction System--New Style (4/2000 and beyond) | 30 |
| 19 | Transaxle--New Style, Parts List | 31 |
| 20 | Recycling System | 32 |
| 21 | Battery Box, Removable | 33 |
| 22 | Vac Wand & Water Jet System | 34 |

WEAR PARTS

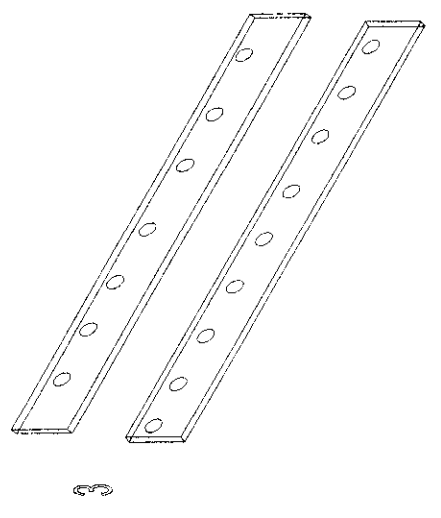
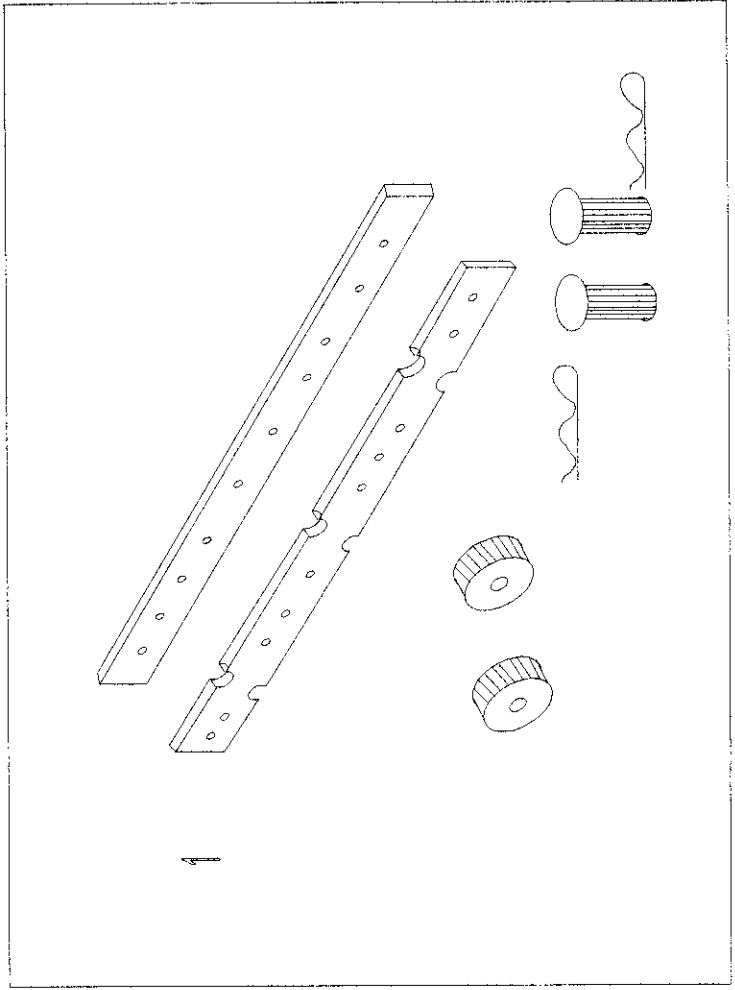
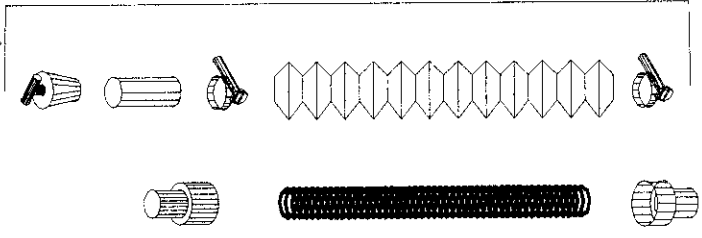
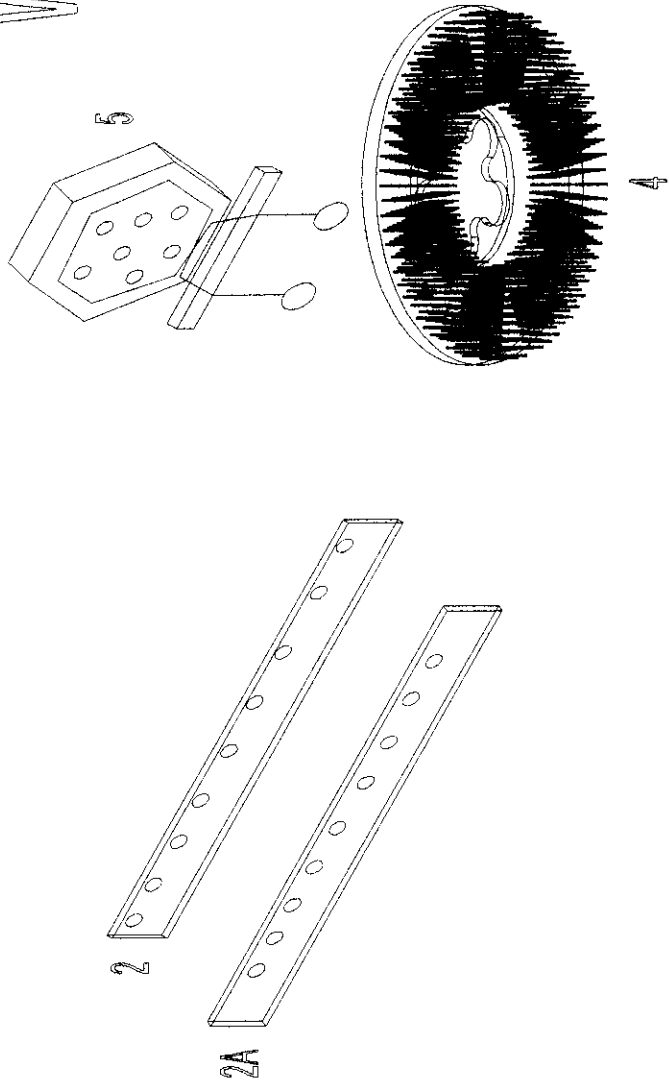

| Reference | DESCRIPTION | Part No. | Qty Req'd. |
|------------------------------------------------------------------------------------------------------------------------------------------------------------------------------------------------------|--------------------------------------------------------------------------------------|-----------|------------|
| Popular Wear Items | | | |
| NOTE: | Squeegee Kits include 2 rear blades, 1 front blade, 2 wheels, 2 wheel pins 2 keepers | | |
| FOR MODEL 40 ONLY (HD and Standard 40 have different squeegees!) | | | |
| 1 | Squeegee Rebuild Kit--Standard Gum Rubber | 7-790G | 1 |
| | Front Squeegee Blade | 7-756G | 1 |
| | Rear Squeegee Blade | 7-753G | 1 |
| | Squeegee Backup Wheels--2, with axles & lockpins | 5-757 | 1 Set of 2 |
| 1A | Squeegee Rebuild Kit--Optional Neoprene Rubber | 7-790N | 1 |
| | Front Squeegee Blade | 7-756N | 1 |
| | Rear Squeegee Blade | 7-753N | 1 |
| | Squeegee Backup Wheels--2, with axles & lockpins | 5-757 | 1 Set of 2 |
| FOR MODEL 40 HD ONLY (HD and Standard 40 have different squeegees!) | | | |
| 1 | Squeegee Rebuild Kit--Standard Gum Rubber | 5-770G | 1 |
| | Front Squeegee Blade | 5-755G | 1 |
| | Rear Squeegee Blade | 5-754G | 1 |
| | Squeegee Backup Wheels--2, with axles & lockpins | 5-757 | 1 Set of 2 |
| 1A | Squeegee Rebuild Kit--Optional Neoprene Rubber | 5-770N | 1 |
| | Front Squeegee Blade | 5-755N | 1 |
| | Rear Squeegee Blade | 5-754N | 1 |
| | Squeegee Backup Wheels--2, with axles & lockpins | 5-757 | 1 Set of 2 |
| 2 | Side Wiper Blades--Set of Two: Gum Rubber (Standard on Machine) | 5-402G | 1 Set of 2 |
| | Side Wiper Blades --Set of Two: Neoprene | 5-402N | 1 Set of 2 |
| 3 | Front & Rear Anti-Splash Curtains | 5-127 | 1 Set of 2 |
| 4 | DISK BRUSHES 18" blocks Listed in order from soft to hard | | |
| NOTE: All brushes with 40- numbers have improved eight point drivers. If you would like to convert your machine from old-style 6 point drivers, the new drivers are free of charge with brush order. | | | |
| | Disk Brush Driver | 21-5000 | 2 |
| A | Tampico (natural fiber) Brush | 40-421T | 2 |
| B | Soft Nylon Brush | 40-421N | 2 |
| C | Polypropylene Brush | 40-421P | 2 |
| D | Light-Grit Brush | 40-421PS | 2 |
| E | Mid-Grit Brush | 40-421C | 2 |
| F | Tuff-Grit Brush | 40-421S | 2 |
| G | Super-Grit Brush | 40-421SS | 2 |
| H | Butcher Wire Brush | 40-421-BW | 2 |

WEAR PARTS

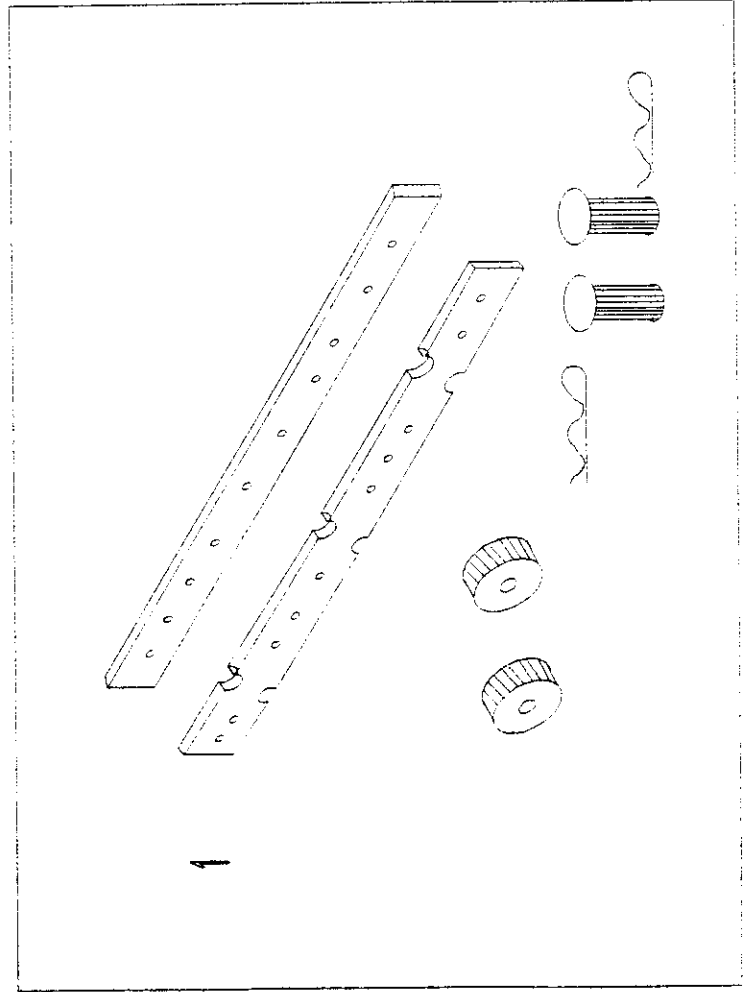
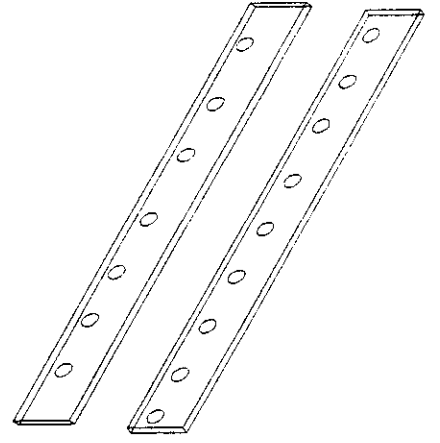
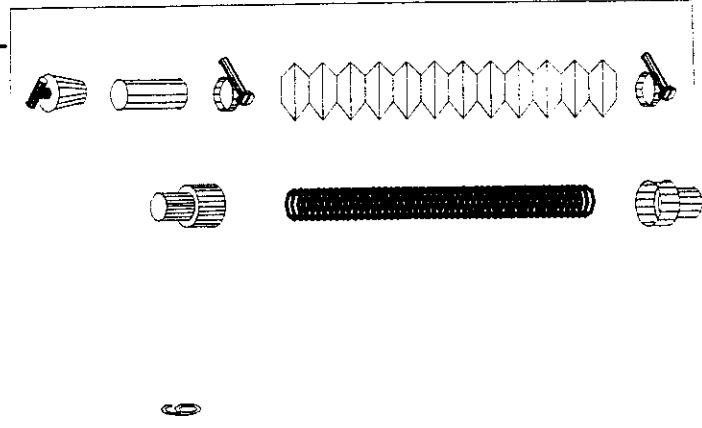
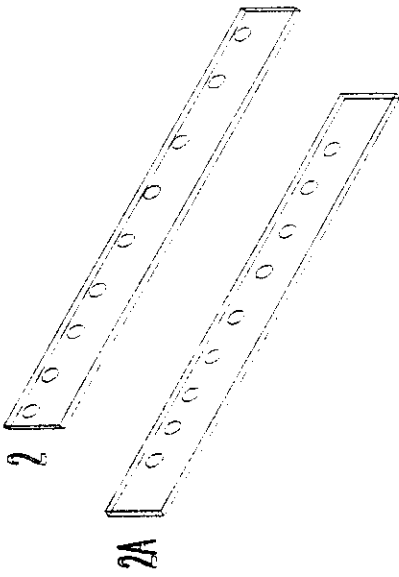
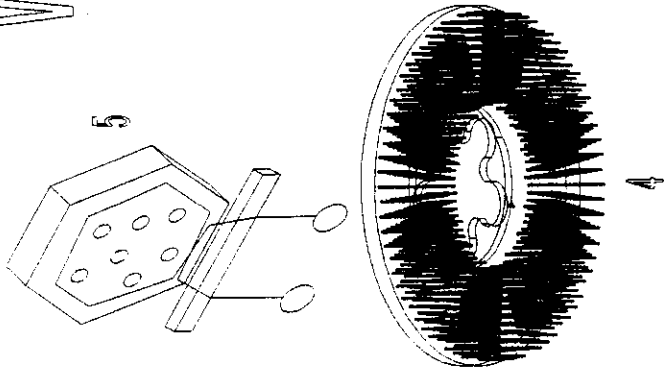

| Reference | DESCRIPTION | Part No. | Qty Req'd. |
|--------------------------------------------------------------|------------------------------------------------------------------------------------------|----------|------------|
| Popular Wear Items (Continued) | | | |
| 4 | Brushes (Continued) | | |
| 1 | Pad Driver (requires pads) | 40-421D | 2 |
| 5 | Disk Brush Repair Kit includes "Scissor" handle, clutch plate, and mounting hardware. | 40-423 | 2 |
| NOTE: Models 40 & 40 HD have different vac hoses! | | | |
| 6 | Vacuum Hose: Complete with Cuffs--For Model 40 ONLY | 38-741 | 1 |
| | Vac Hose Cuff | | 2 |
| | Vacuum Hose: Complete with Cuffs--For Model 40 HD ONLY | 5-705 | 1 |
| | Vac Hose Cuff | | 1 |
| 7 | Drain Hose, complete Includes stopper, clamps and stainless steel tube. | 5-730 | |
| 8 | Cylindrical Brushes (Not illustrated) (From softest to harshest) | | |
| | Tampico (Tan) | 5-521T | |
| | Soft nylon (White) | 5-521N | |
| | Light Grit (Grey) | 5-521PS | |
| | Mid Grit (Blue) | 5-521C | |
| | Tough Grit (Green) (formerly 5-521G) | 5-521S | |
| | Side Broom Brushes (optional) | | |
| | Polypropylene fiber 17" diameter | 4-402 | |
| | Nylon fiber 17" diameter | 4-402N | |
| 9 | Squeegee wheel pin (2 pins with keepers) | 4-403 | |

UPPER BODY

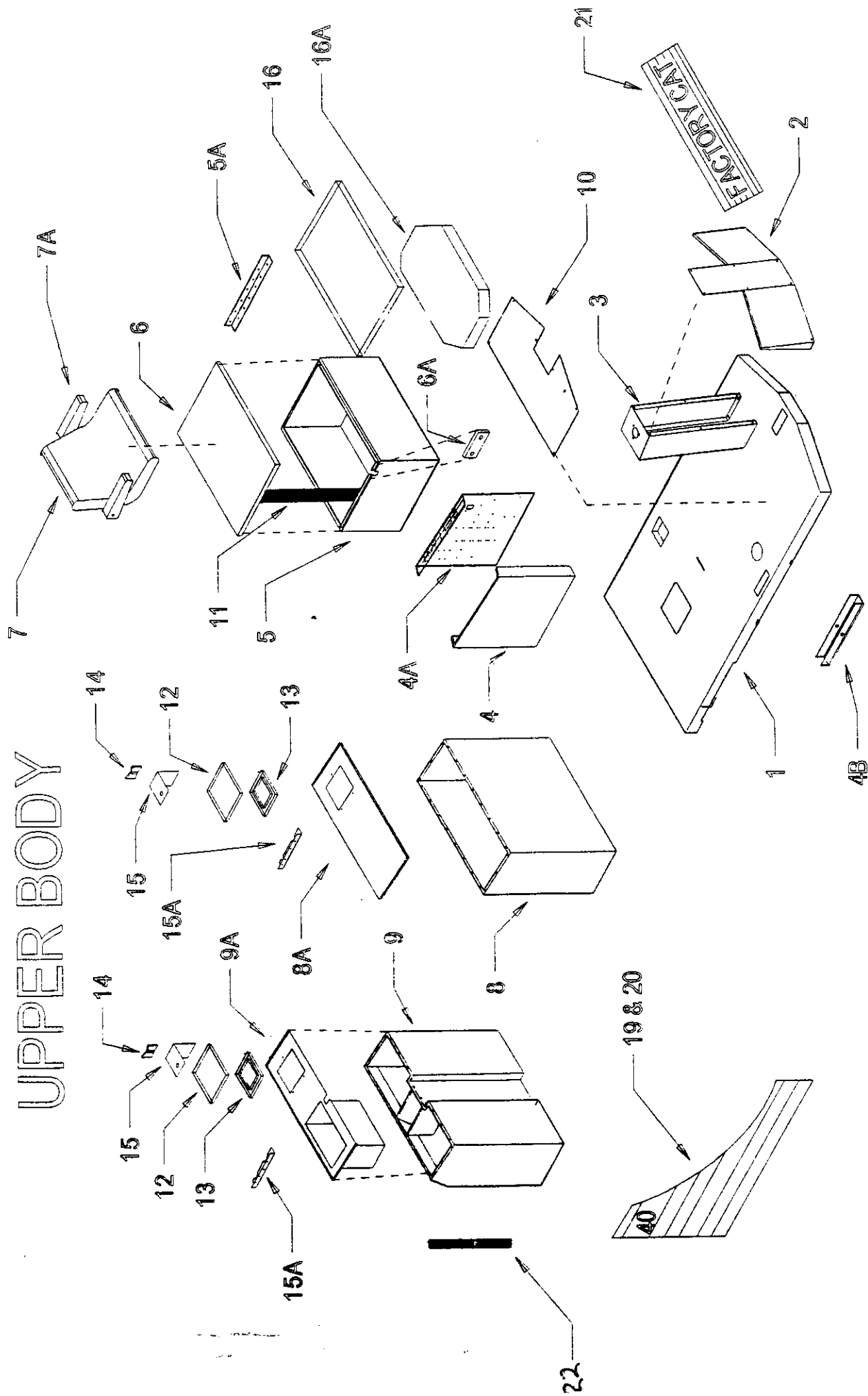

| Reference | DESCRIPTION | Part No. | Qty Req'd. |
|-----------------------------------|------------------------------------------------------------------------|----------|------------|
| BODY PARTS (Upper Section) | | | |
| 1 | Mainframe | 5-110 | 1 |
| 2 | Front Apron | 8-118 | 1 |
| 3 | Steering Pedestal | 8-117 | 1 |
| 4 | CENTRAL COMMAND HOUSING | | |
| | <i>SEE ALSO BREAKDOWN IN CENTRAL COMMAND SECTION"</i> | | |
| 4 | Old Style Central Command Box (before 3/99) Includes front only | 5-112 | 1 |
| 4A | Old Style Central Command Rear Plate (before 3/99) (holds electricals) | 5-292 | 1 |
| 4 | Box Cover (New style: flat piece of steel) | 5-114 | 1 |
| 4A | Box New Style (5 sided box; holds electricals) | 5-113 | 1 |
| 4B | Wiring Channel | 5-147 | 1 |
| 5 | Battery Box | 5-129 | 1 |
| 5A | Battery Box Hinge | 5-128 | 1 |
| 6 | Battery Box Lid | 5-146 | 1 |
| 7 | Adjustable Seat | 8-142 | 1 |
| 7A | Armrest Set for seat | 8-143A | 1 |
| 8 | Solution Tank, Complete for Model 40 (Polyethylene) | 5-687 | 1 |
| | Solution Tank, Complete for Model 40 HD (Stainless Steel) 52 Gallon | 5-401 | 1 |
| | Solution Tank Complete for Model 40HD (Stainless) 70 Gallon Capy | 5-914 | 1 Opt |
| 9 | Recovery Tank, Complete for Model 40 (Polyethylene) | 5-689 | 1 |
| | Recovery Tank, Complete for Model 40 HD (Stainless Steel) 55 Gal | | 1 |
| | See breakdown in Recovery Section | 5-701 | 1 |
| | Serial HI40-3802 & Before | 5-699 | 1 |
| | Serial HI40-3803 & After | | |
| | Recovery Tank, Complete for Model 40 HD (Stainless) 70 Gallon | 5-915 | 1 Opt |
| 10 | Nonskid floor plate | 8-161 | 1 |
| 11 | Battery Box Lid Strap | 5-133 | 1 |
| 12 | Tank Fill Door Stainless Steel (Model 40 HD only) | 5-411 | 2 |
| | Tank Fill Door Plastic porthole (Model 40 only) Complete with frame | 7-425 | 2 |
| 13 | Tank Fill Door Gasket (Model 40 HD Only) | 5-412N | 2 |
| 14 | Knob, tank door (Model 40 HD Only) | 5-418 | 2 |
| 15 | Clip, Tank Fill Door, Stainless steel (Model 40 HD Only) | 5-417 | 2 |
| 16 | Battery tray, poly | 5-134 | 1 |
| 16A | Plywood battery underlayment | 5-138 | 1 |
| 17 | Battery tray drain hose/ Not Shown | 5-137 | 1 |
| 19 | RH "40 Decal" For Model 40 | 5-153 | 1 |
| | RH "40 Decal" For Model 40 HD | 5-150 | 1 |

UPPER BODY

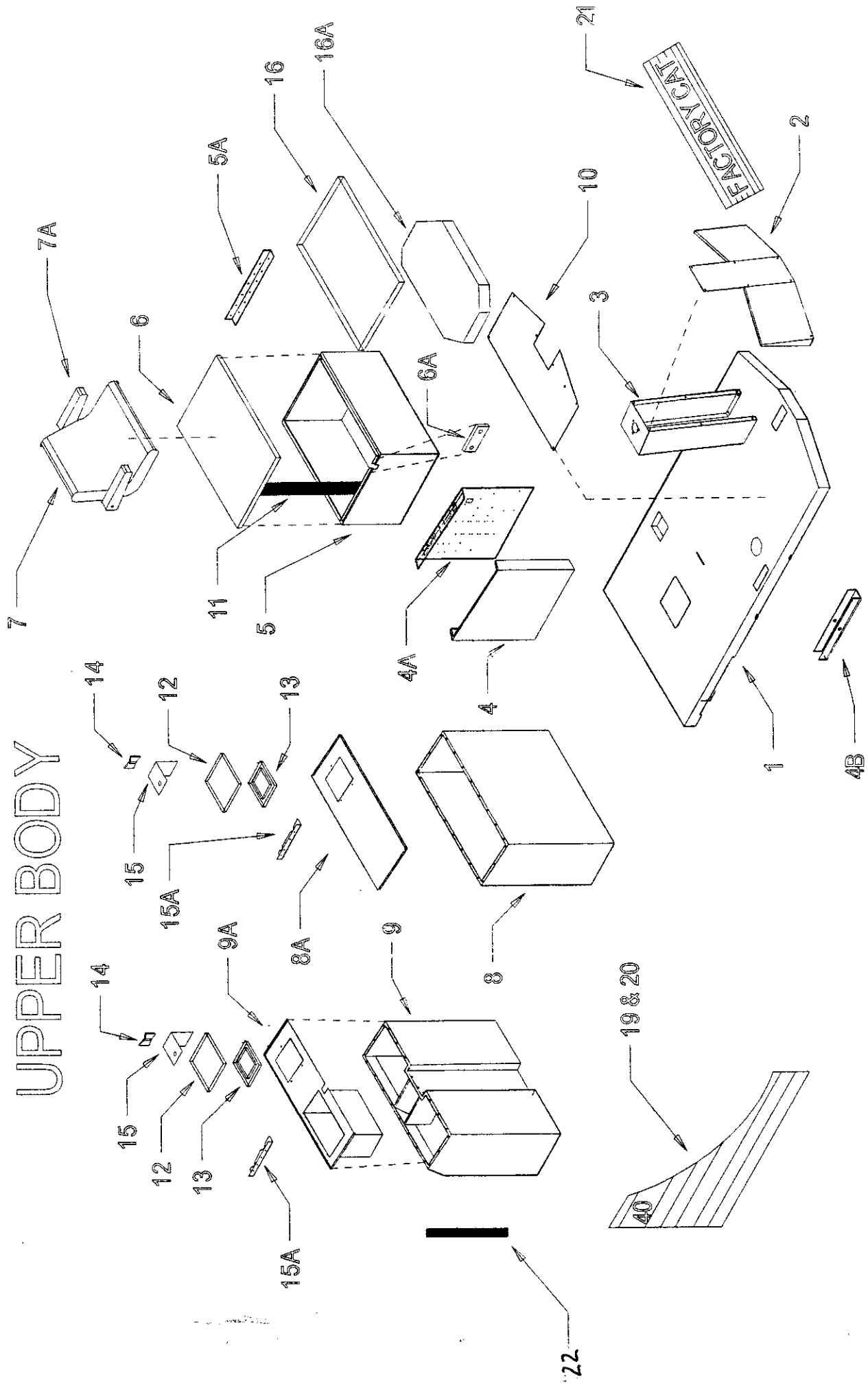

| Reference | DESCRIPTION | Part No. | Qty Req'd. |
|-----------------------------------------------|-------------------------------------------------------------------|----------|------------|
| BODY PARTS (Upper Section) (continued) | | | |
| 20 | LH "40" Decal for Model 40 | 5-153 | 1 |
| | LH "40" Decal for Model 40 HD | 5-151 | 1 |
| 21 | Factory Cat" front Decal | 8-152 | 1 |
| 22 | Tank holddown strap for 50 Gal poly and 52/55 Gal Stainless tanks | 5-722 | 1 |
| | Tank holddown strap for 70 gal stainless tanks. | 5-722B | 1 opt |
| | Clamp rear | 5-724 | 1 |
| | Clamp front | 5-725 | 1 |
| | Tie down hook | 5-723 | 1 |
| Not Illustrated | Antisplash curtain clamp set (not shown) | 5-131 | 1 |

LOWER BODY

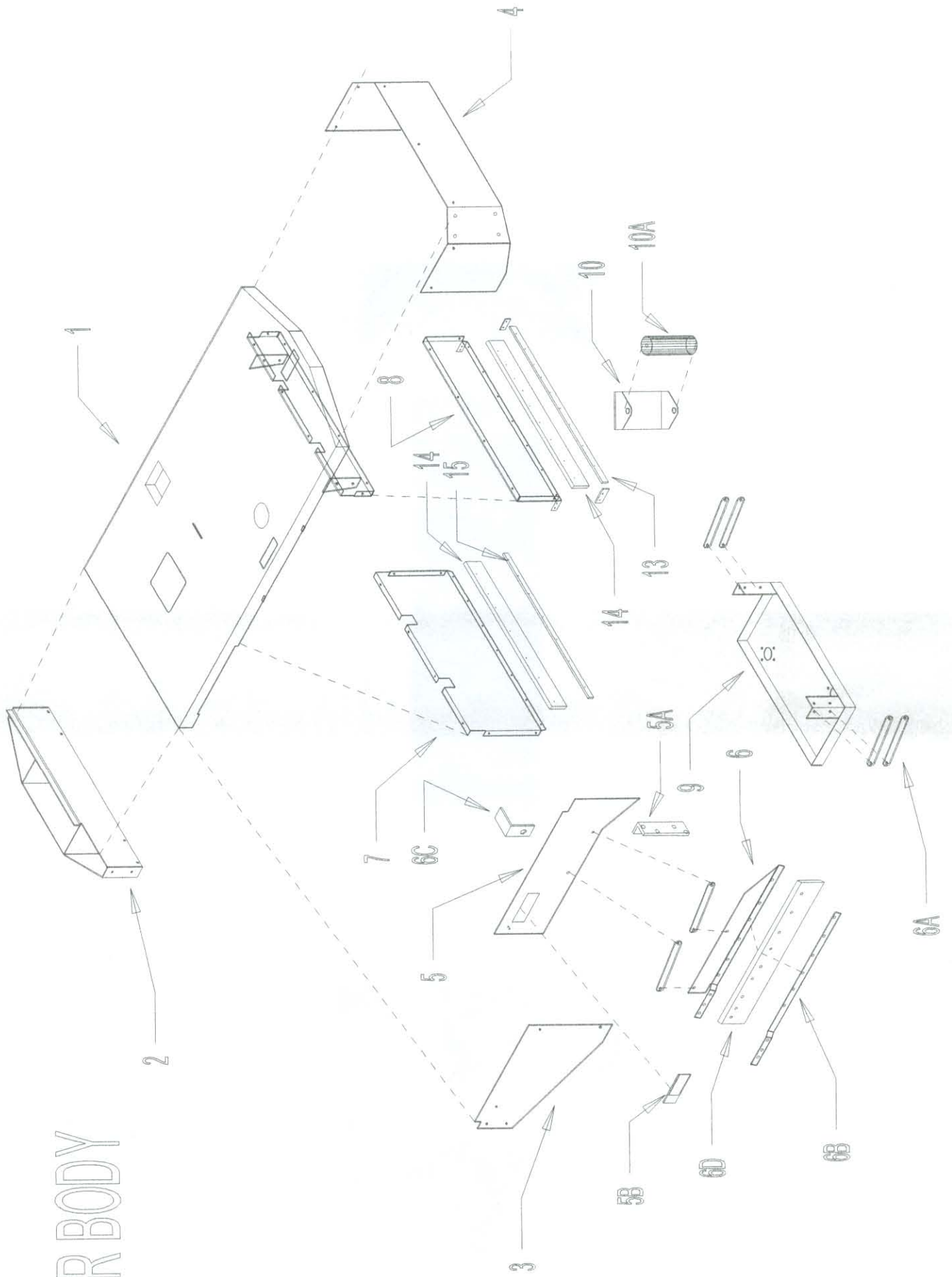

| Reference | DESCRIPTION | Part No. | Qty Req'd. |
|-----------------------------------|--------------------------------------------------------------------|----------|-------------|
| BODY PARTS (Lower Section) | | | |
| 1 | Mainframe | 5-110 | 1 |
| 2 | Rear Bumper | 5-119 | 1 |
| 3 | Quarter panel (left or right) | 5-120 | 2 |
| 4 | Front bumper (New style fits all machines, cyl & disk; Subs 5-135) | 5-844 | 1 |
| 5 | Righthand Door | 5-121R | 1 |
| | Lefthand door (not shown) | 5-121L | 1 |
| 5A | Door Hinge | 5-122 | 2 |
| 5B | Door Latch | 5-130 | 2 |
| 6 | Righthand wiper | 5-123R | 1 |
| | Lefthand wiper (Not shown) | 5-123L | 1 |
| 6A | Lateral arm, scrubhead | 5-124 | 4 |
| 6B | Wiper blade mounting strip | 5-403 | 2 |
| 6C | Wiper Lifting Bracket | 5-123B | 2 |
| 6D | Wiper Blade (Gum Rubber = Standard; Color brown) | 5-402G | 2 |
| | Wiper Blade (Neoprene = Optional; Color Black) | 5-402N | 2 |
| 6E | Wiper Blade mounting strip bolt (not shown) 1 set of 20 | 5-419 | 1 set of 20 |
| 7 | Rear Splash Panel | 5-125 | 1 |
| 8 | Front Splash Panel | 5-126 | 1 |
| 9 | Scrubhead (disk machines only) | 5-402 | 1 |
| 10 | Roller & Bracket Assy Complete | 7-125 | |
| | Roller bracket (part of roller option) | 7-126 | 2 |
| | Roller (part of roller option) | 7-125A | 2 |
| 13 | Front Splash Curtain Holddown Bar Set | 5-131 | 1 |
| | Long Bar | 5-131L | 1 |
| | Short Bar | 5-131S | 2 |
| 14 | Splash Curtain Set (front + rear curtains) | 5-127 | 1 Set |
| 15 | Rear Splash Curtain Holddown Bar | 8-578 | 1 |
| Not illustrated | 1" Wide Bumper strip--sold by the foot (not shown) | 8-130 | 8 Feet |
| Not illustrated | Complete Warning & Instruction Label Set (not illustrated) | 5-150D | 1 |

ELECTRICAL PARTS

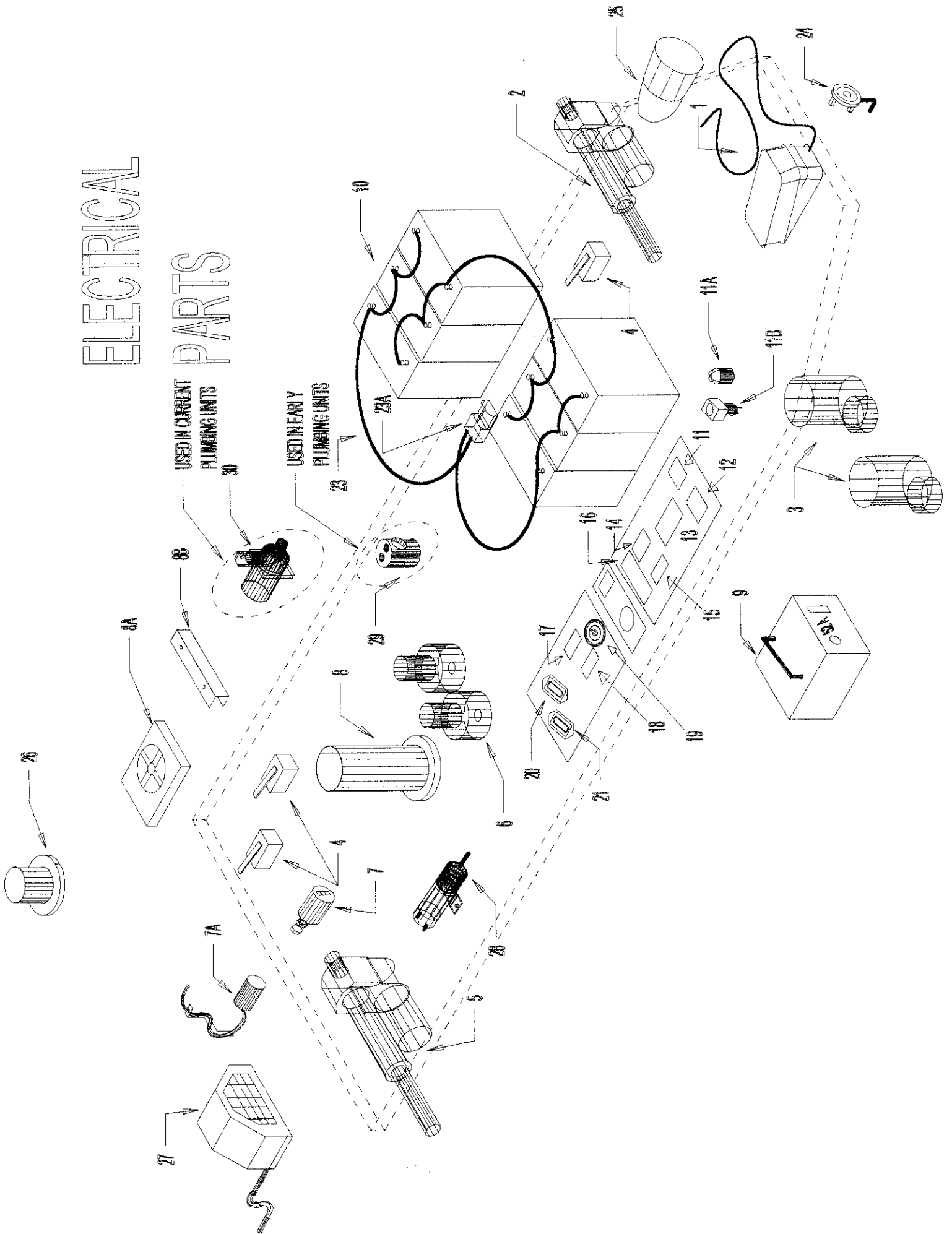

| Reference | DESCRIPTION | Part No. | Qty Req'd. |
|--------------------|------------------------------------------------------------------------------------------------------------------------------------|----------------------|------------|
| Electricals | | | |
| 1 | Foot pedal <i>Includes wiring kit; Molex connector to be field installed</i> | 5-275 | 1 |
| 2 | Scrubhead Lift/Lower Actuator | 5-221 | 1 |
| 3 | Gear Motor for Disk Brush Machines: 200 RPM ; 1 HP | 5-222 | 2 |
| | Gear Motor for Disk Brush Machines: 350 RPM; 1 HP | 38-222 | 2 Opt |
| Not Illustrated | Scrub Motor for Cylindrical Brush Machines | 8-211 | 1 |
| Not Illustrated | Cooling Fan for Cylindrical Brush Machines | 5-214 | 1 |
| 4 | Scrubhead & Squeegee Lift Limit Switch | 5-223 | 3 |
| 5 | Squeegee Lift Electric Actuator | 5-224 | 1 |
| 6 | Vac Motor <i>Note: 2 vac motors are standard on Model 40HD; 1 std & 1 opt. on 40</i> | 5-225 | 1 or 2 |
| Not Illustrated | Vac motor cap (plastic protective top to vac motor) | 5-225A | |
| 7 | Recovery Tank Float Switch (Units built before 6/98) | 5-226 | 1 |
| 8 | Traction Motor (Units built before 4/2000) | 8-211 | 1 |
| | <i>See Traction Drive Section for units built after 4/2000. Motor on new production is in the axle</i> | | |
| 8A | Traction Motor's Supplemental Cooling Fan (Units built before 4/2000) | 5-212 | 1 |
| 8B | Traction Motor's Fan Bracket (Units built before 4/2000) | 5-213 | 1 |
| 9 | Charger--Console Type, 36 Amp, Automatic (for 4 battery machines) | 7-244 | 1 |
| 9a | Deluxe Charger--Console Type, 52 Amp, Automatic <i>Above is used on 6 battery machines (6 X 185 AH or 6 X 205 AH)</i> | 5-246 | 1 |
| 10 | 12 Volt, 185 Amp Hour Battery (Standard) <i>Four batteries are standard, six optional on 40; six batteries standard on 40HD</i> | 4-271 | 6 |
| 11 | Solution Empty Light (Yellow Lens) (Model 40 HD only) | 5-230 | 1 |
| | | Bulb | |
| 12 | Recovery Full Light (Red Lens) (40 HD) | 5-231 | 1 |
| | | Bulb | |
| 13 | Downpressure Gauge including control module | 5-236 | 1 |
| 14 | Brush Switch--Up & Down & Pressure | 5-233 | 1 |
| 15 | Squeegee Switch --Up and Down | 5-234 | 1 |
| 16 | Switch on-off. <i>Above switch used for vac wand on/off and for solution flow on/off</i> | 8-231 | 1 |
| 17 | Green Indicator Light | 8-232 | 1 |
| 18 | Forward/Reverse Switch (Red) | 5-237 | 1 |
| 19 | Key Switch (All keyswitches keyed alike) | 8-234 | 1 |
| | | Spare Key (set of 2) | |
| 20 | Battery Condition Meter | 8-261 | 1 |

ELECTRICAL PARTS

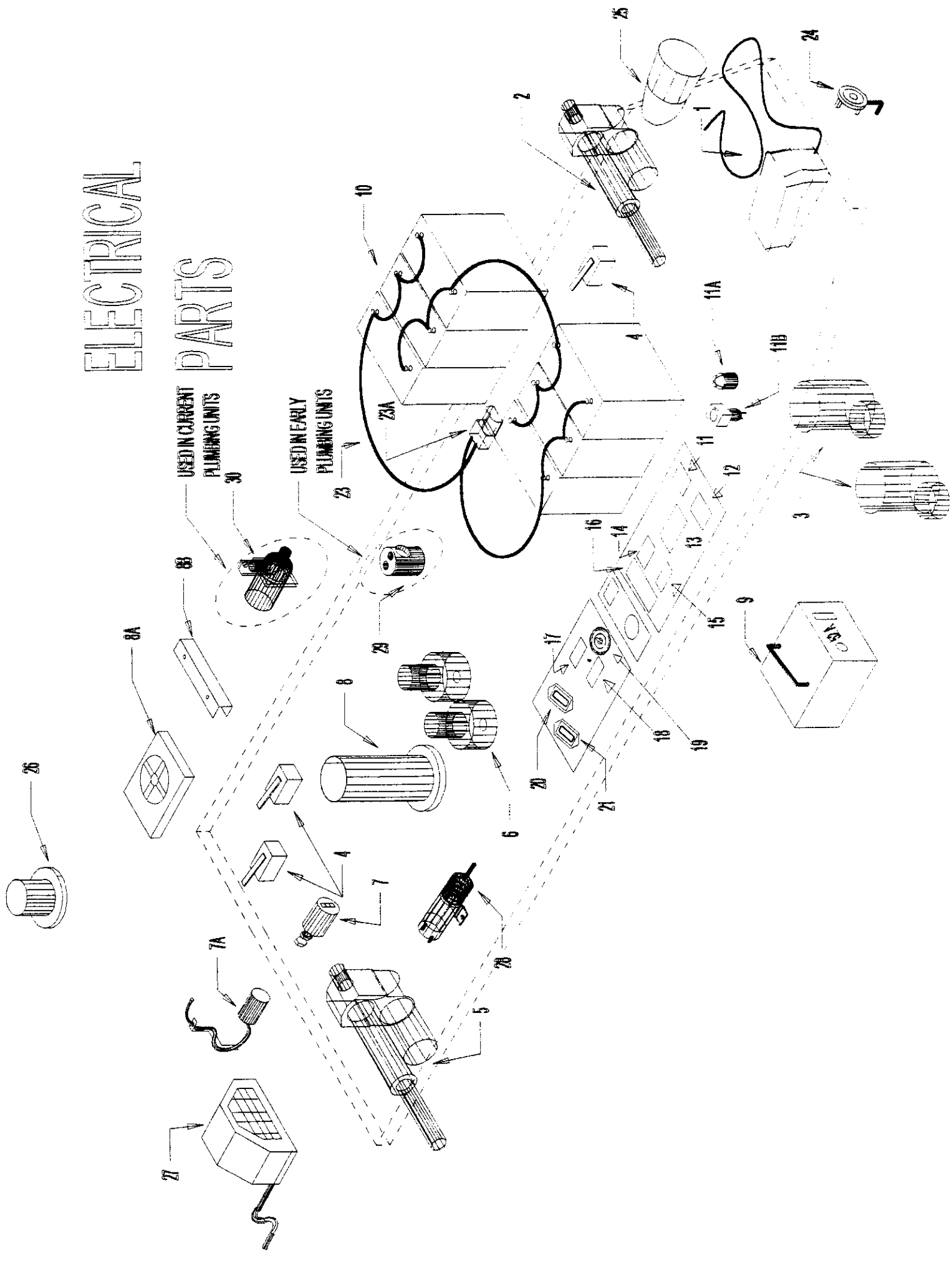

| Reference | DESCRIPTION | Part No. | Qty Req'd. |
|-----------------|--------------------------------------------------------------------------------------------------------------------------------------------------------------------------------|----------|-----------------|
| | Electricals (Continued) | | |
| 21 | Hour Meter | 8-262 | 1 |
| 22 | Label Set for Controls (Units built before 10/98 with removable top panels) <i>Includes Front & Rear Control Panels and Downpressure Gauge Readout</i> | 5-156 | 1 Set |
| 23 | Label Set for Controls (1 piece label; current units with removable side panel) | 5-150D | 1 |
| 23A | Wiring Harness for Battery Set--Complete | 5-252 | 1 |
| 23B | Red 175 Connector | 5-260 | 1 |
| 24 | Set of Rubber Terminal Covers | 5-261 | Set of 12 |
| | Horn | 8-294 | 1 |
| Not Illustrated | Horn Button | 8-294B | 1 |
| 25 | Headlight (optional on 40) | 8-291 | Opt |
| 26 | Strobe Light (optional on 40) | 8-293 | Opt |
| | 1 amp fuse | 8-293F | |
| 27 | Backup Alarm | 8-292 | Opt |
| 28 | Parking Brake Solenoid (Applies only to units built before 4/2000) <i>For units after 4/2000, see Traction Drive Section in this book; brake is integral with new units</i> | 8-295 | 1 |
| 29 | Solution Tank Electrovalve (Old style; brass; used prior to 1998) | 5-244 | 1 |
| 30 | Solution Tank Electrovalve (New; Clear cover; used currently) | 7-245 | |
| Not Illustrated | Shunt see Central Command | 5-295 | 1 |
| Not Illustrated | Diode see Central Command | 5-296 | 2 |
| | HARNESSES SET: Includes All of the Following: | 5-253 | 1 |
| Not Illustrated | Parking Brake harness (For units built before 4/2000) | 5-254 | 1 |
| | Parking Brake harness (For units built AFTER 4/2000) | 5-254A | 1 |
| Not Illustrated | Central Command to Brushhead | 5-255 | 1 |
| Not Illustrated | Central Command to Traction Motor (Units built before 4/2000) | 5-256 | 1 |
| | Central Command to Traction Motor (Units built AFTER 4/2000) | 5-614 | |
| Not Illustrated | Central Command to Vacuum motors and tank stop switch | 5-257 | 1 |
| Not Illustrated | Central Command to Squeegee Contact Switches | 5-258 | 1 |
| Not Illustrated | Central Command to Horn | 5-259 | 1 |
| Not Illustrated | Central Command to Foot Pedal | N.S.S. | <i>In Pedal</i> |
| Not Illustrated | <i>Note: This is integral with Foot Pedal, Part No. 8-290</i> | | |
| Not Illustrated | Central Command to Solution Tank Solenoid Valve | 5-262 | 1 |
| Not Illustrated | Central Command to Strobe (Option) | 5-263 | Opt 1 |
| Not Illustrated | Central Command to Reverse Alarm (Option) | 5-264 | Opt 1 |
| Not Illustrated | Central Command to Headlight (Option) | 5-265 | Opt 1 |

CENTRAL COMMAND

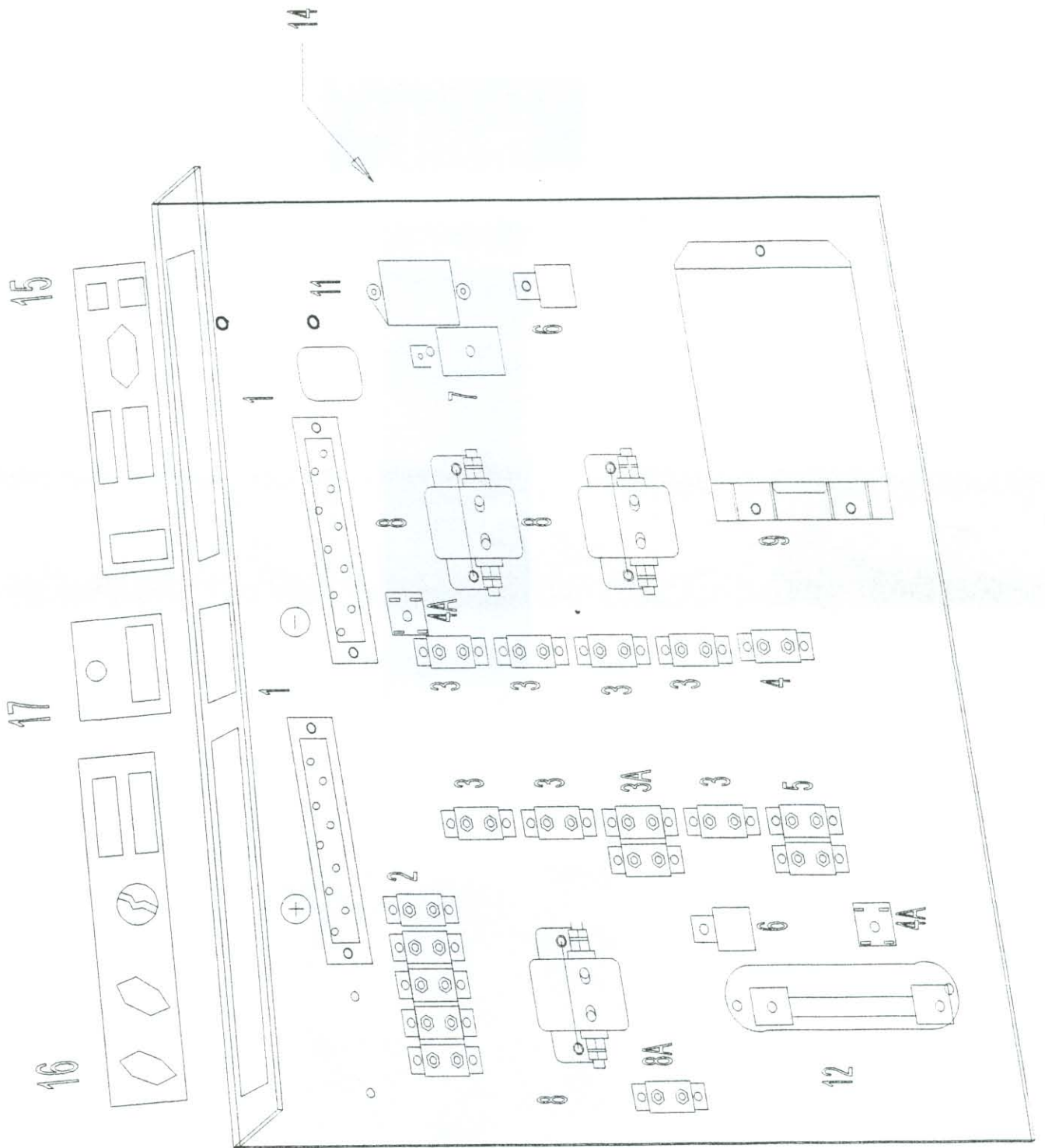

| Reference | DESCRIPTION | Part No. | Qty Req'd. |
|-----------------|---------------------------------------------------------------------------------------------------------------------------------------------------------------------------------------------|----------|------------|
| | Central Command | | |
| Not Illustrated | Complete Central Command Assembly, <i>Ready to install on machine, including all parts below, and box, and switches and gauges. Brand New. Current style box w/removable door</i> | 5-280 A | 1 |
| Not Illustrated | Complete Central Command Assembly <i>Same as above, but rebuilt and fully tested by Factory.</i> | 5-281A | 1 |
| | <i>When ordering above, state: (1) turn type or pull type solution flow control, (2) 40 or 40 HD, (3) Cylindrical or Disk Type brushes.</i> | | |
| | <i>Note that Central Commands now supplied are of "NEW STYLE" with removable side panel. These units will fit old style machines.</i> | | |
| 1 | Buss Bar | 5-287 | 2 |
| 2 | 200 Amp Main Breaker | 5-288 | 1 |
| 3 | 6 Amp Circuit Breaker | 8-284 | 6 |
| 3A | 12 Amp Circuit Breaker | 5-284A | 2 |
| 4 | 50 Amp Circuit Breaker (Vac Motors; Model 40 HD, and 40 with dual option) | 5-289 | 1 |
| | 25 Amp Circuit Breaker (Single Vac Motor; standard on Model 40) | 7-286 | 1 |
| 4A | Diode Bridge | 5-296 | 2 |
| 5 | 80 Amp Circuit Breaker (Dual Disk Scrub Motors) | 5-298 | 1 |
| | 60 Amp Circuit Breaker (Cylindrical Scrub System) | 7-285A | 2 |
| 6 | 15 Amp Relay | 5-293 | 2 |
| 7 | Vacuum System Timer | 5-294 | 1 |
| 8 | 80 Amp Relay | 8-283 | 3 |
| Not Illustrated | EMF Suppression diode | 5-270 | 2 |
| | <i>Do not use diode on Vac Relay! Always install diode with mark toward +</i> | | |
| 9 | Computer Control (NEW Model 1227 for units prior to 4/2000, 150 amp) | 5-285 | 1 |
| | Computer Control (Model 1227 150 amp REBUILT) | 5-285R | 1 |
| | Computer Control (NEW Model 1227 for units After 4/2000, 200 amp) | 5-2852 | 1 |
| | <i>Control update kit: for mounting 1227 to unit with Old Style Model 1213 Control</i> | Kit T-62 | 1 |
| 10 | For Dashboard Switches & Instruments, see Electrical Section | | |
| Not Shown | Complete Wiring Harness for Central Command | 5-286 | 1 |

CENTRAL COMMAND

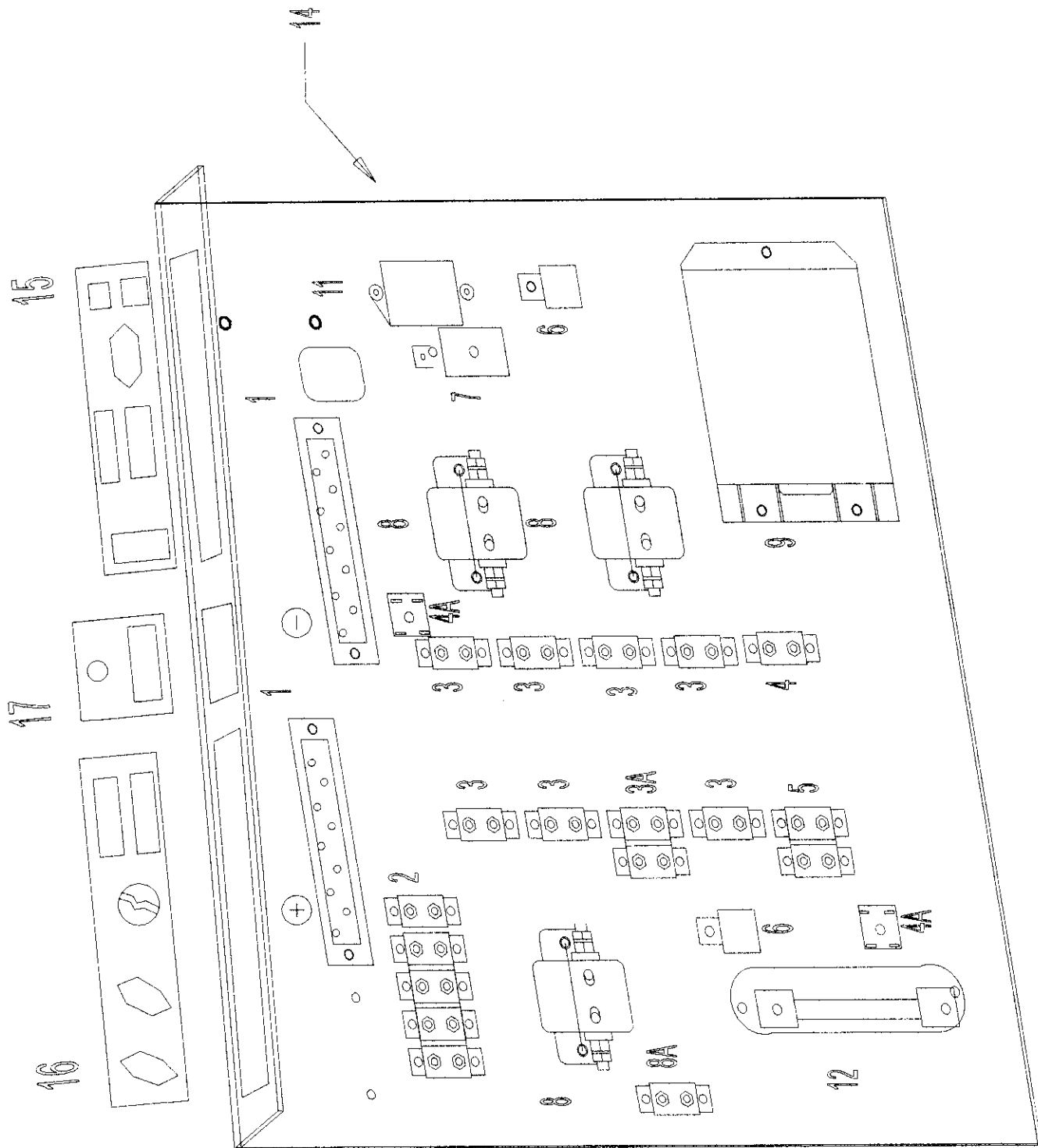

| Reference | DESCRIPTION | Part No. | Qty Req'd. |
|-----------------|-------------------------------------------------------------------------|----------|------------|
| | Central Command (Continued) | | |
| 11 | Downpressure Gauge Module | 5-236 | 1 |
| 12 | Shunt | 5-295 | 1 |
| 13 | Central Command Box (Old Style) | 5-112 | 1 |
| | Central Command Box (New Style with Removable cover; holds electronics) | 5-113 | 1 |
| 14 | Central Command Cover (Old Style) Holds Electricals | 5-292 | 1 |
| | Central Command Cover (New Style; flat piece of steel) | 5-114 | 1 |
| 15 | Front Switchpanel (Old Style Units only) | 5-290 | 1 |
| 16 | Rear Switchpanel (Old Style Units Only) | 5-291 | 1 |
| 17 | Middle Switchpanel (Old Style Units Only) | 5-299 | 1 |
| Not Illustrated | Red 175 Amp Connector with crimp-on Contacts | 5-260 | 2 |
| | Red 50 Amp Connector with Crimp-on Contacts | 4-257 | 2 |
| | Grey 50 Amp Connector with Crimp-on Contacts | 4-256 | 2 |
| | White 50 Amp Connector with Crimp-on Contacts | 5-219 | 2 |

SCRUB DECK PARTS

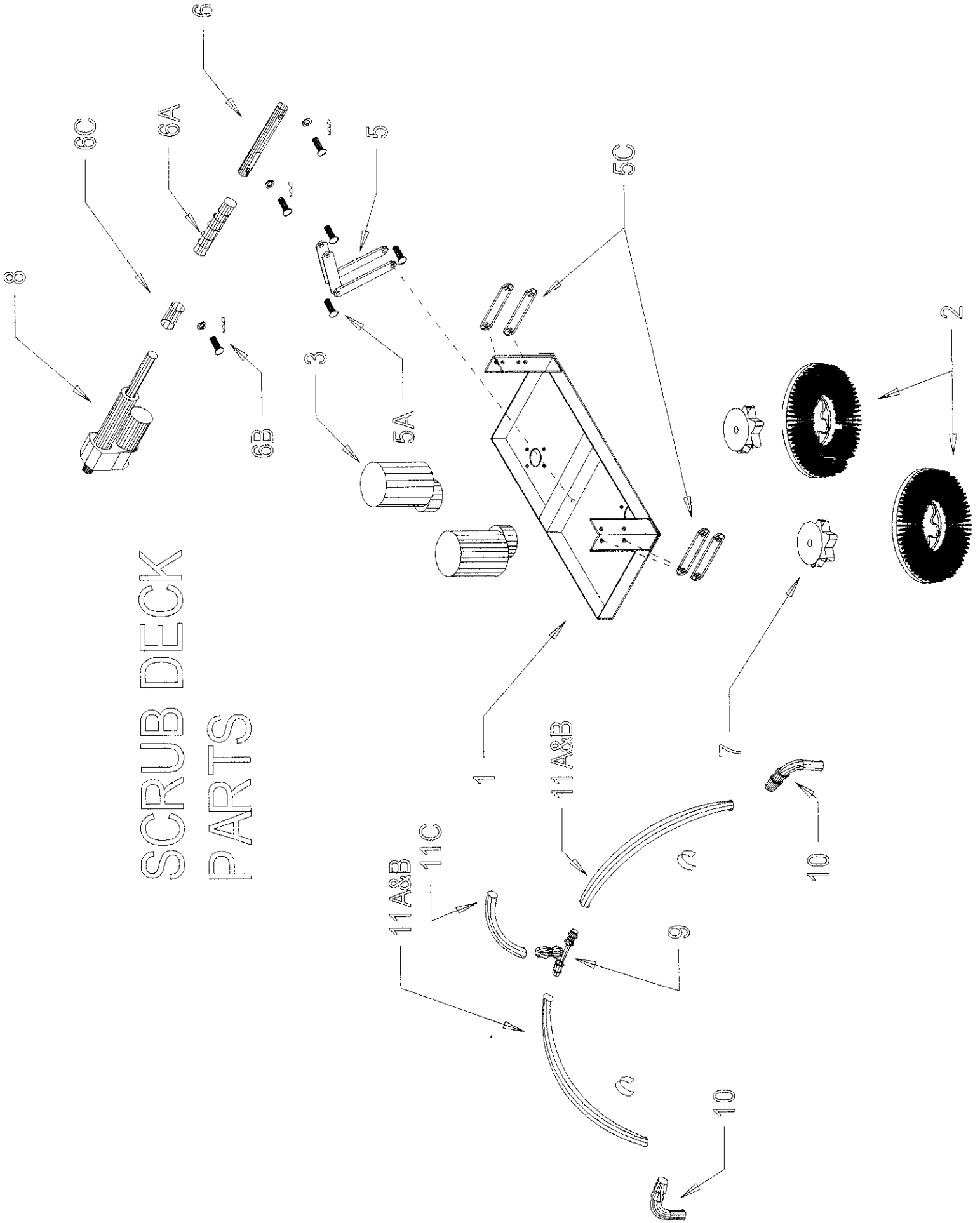

| Reference | DESCRIPTION | Part No. | Qty Req'd. |
|-------------------------------------------------------------------------------------------------------------------------------------------------------------------------------------------------------------|---------------------------------------------------------------------------------------|----------------|------------|
| SCRUB DECK PARTS: For Disk Brush Machines Only | | | |
| 1 | Scrubhead | 5-402 | 1 |
| 2 | DISK BRUSHES 18" blocks Listed in order from soft to hard | | |
| <i>NOTE: All brushes with 40- numbers have improved eight point drivers. If you would like to convert your machine from old-style 6 point drivers, the new drivers are free of charge with brush order.</i> | | | |
| | Disk Brush Driver | 21-5000 | 2 |
| A | Tampico (natural fiber) Brush | 40-421T | 2 |
| B | Soft Nylon Brush | 40-421N | 2 |
| C | Polypropylene Brush | 40-421P | 2 |
| D | Light-Grit Brush | 40-421PS | 2 |
| E | Midi-Grit Brush | 40-421C | 2 |
| F | Tuff-Grit Brush | 40-421S | 2 |
| G | Super-Grit Brush | 40-421SS | 2 |
| H | Butcher Wire Brush | 40-421-BW | 2 |
| I | Pad Driver (requires pads) | 40-421D | 2 |
| 2A | | 40-433 | 2 |
| 2B | | 40-423 | 2 |
| <i>Kit includes "scissors" handle, clutch plate and mounting hardware also fits driver 5-421D</i> | | | |
| 3 | Scrub Motor, 1 HP, 200 RPM | 5-222 | 2 |
| 3A | Scrub Motor, 1 HP, 350 RPM | 38-222 | 2 |
| 4 | Clevis Pin 1/2" x 3" & Ring | 5-405 | 1 |
| 5 | Scissorlift Assembly | 5-404 | 1 |
| 5A | Arm Mount Hardware Set includes 1 shoulder bolt, 2 nylon washers, 1 nylock nut | 5-145 | 1 |
| | Scissorlift Link | 5-404A | |
| 5C | Scrubhead Lateral Arm | 5-124 | 4 |
| 6 | Spring Tube | 5-406 | 1 |
| 6A | Scrubhead Down Pressure Spring (standard strength) | 5-408 | 1 |
| 6B | Spring Tube Pin (1/2" X 1-3/4") | 5-407 | 1 |
| 6C | Spring Retainer | 5-409 | 1 |
| Not Illustrated | Spring Cap | 5-409A | 1 |
| 7 | Scrub Brush Driver (brush or pad driver mounts to it) | 5-430 | 2 |
| 7A | Brush Driver Key | 5-431 | 2 |
| 7B | Driver Mounting Bolt and Washers | 5-432 | 2 |
| 8 | Electric Actuator (1000#) | 5-221 | 1 |
| 9 | 1/2" Plastic Barb Tee | 5-446 | 1 |
| 9A | 5/8" Plastic Barb Tee | 7-247 | 1 |
| 9B | 1/2" Barb to 1/2" NPT Elbow | 5-447 | 1 |

SCRUB DECK PARTS

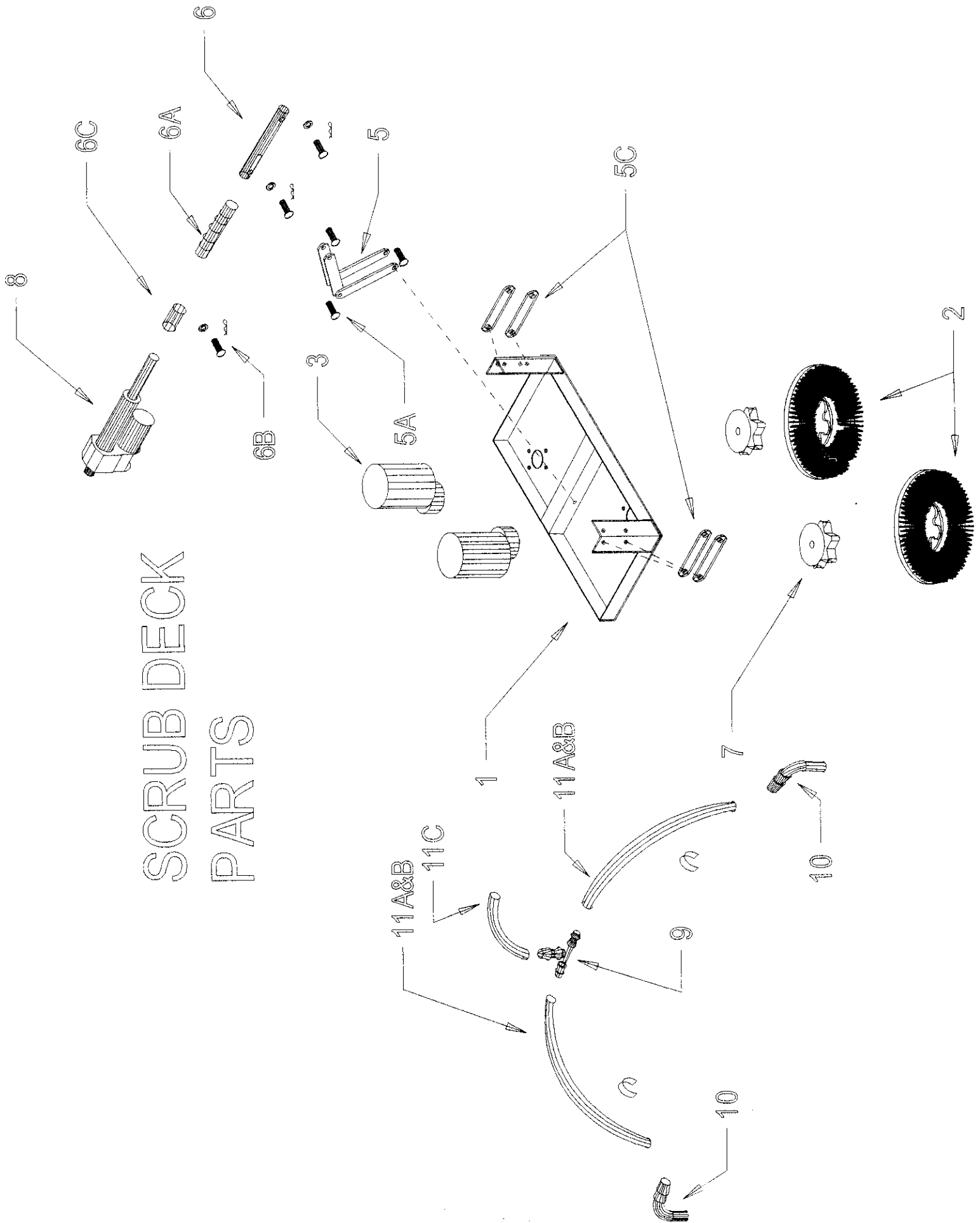

| Reference | DESCRIPTION | Part No. | Qty Req'd. |
|-------------------------------------------------------|-----------------------------|----------|--------------|
| SCRUB DECK PARTS: For Disk Brush Machines Only | | | |
| 10 | 5/8" Barb to 1/2" NPT Elbow | 7-248 | 2 |
| 11A | 5/8" Hose, nylon reinforced | 5-460 | Sold by foot |
| 11B | 1/2" Hose, nylon reinforced | 5-440 | Sold by foot |
| 11C | 5/8" Clear PVC Hose | 5-465 | Sold by foot |

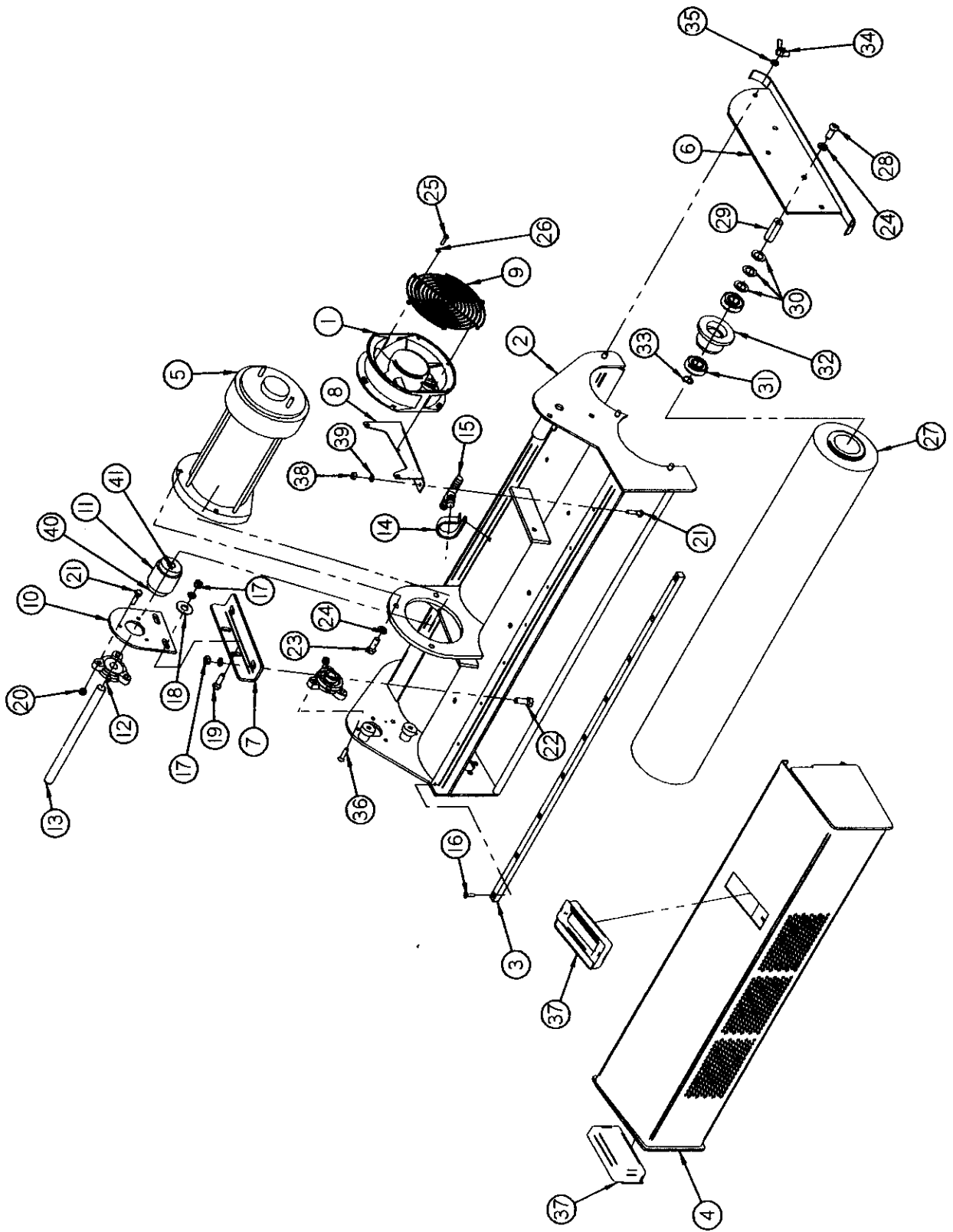

| Reference | DESCRIPTION | Part No. | Qty Req'd. |
|--------------------------------------------------------|--------------------------------------------------------------------------------------------|----------|------------------|
| SCRUB DECK PARTS: For Cylindrical Machines Only | | | |
| FIRST PAGE | | | |
| 1 | 24V Cooling Fan | 5-214 | 1 |
| 2 | Cylindrical body | 5-800 | 1 |
| 3 | Hopper Slide | 5-832 | 1 |
| 4 | Hopper | 5-802 | 1 |
| 5 | Motor, 24V, 2HP | 8-211 | 1 |
| Not Illustrated | Wire harness for above (Red 50 connector to motor) | | |
| Not Illustrated | Motor Terminal Cover, Red | | |
| 6 | Brush Idler Door | 8-278 | 1 |
| 7 | Bearing Plate Mount | 5-801 | 1 |
| 8 | Fan Mount | 5-8101 | 1 |
| 9 | Fan Guard | 5-8100 | 1 |
| 10 | Bearing Plate | 5-214A | 1 |
| 11 | Coupling | 5-8102 | 1 |
| | <i>This flex coupling replaces old rigid coupling 5-835. Call service dept for details</i> | 8-613 | 1 |
| 12 | Driveshaft Bearing | 5-829 | 2 |
| 13 | Driveshaft | 5-836 | 1 |
| 14 | Loop clamp | H-3225T5 | 1 |
| 15 | 5/8" Plastic Barb | 7-247 | 1 |
| Not Illustrated | Hose 5/8" Clear PVC | H-017 | Sold by the foot |
| 16 | FHP#10-32 X 3/4 SS | H-72684 | 9 |
| 17 | NH 5/16" - 18 SS | H-70711 | 4 |
| 18 | FW 5/16" | H-33080 | 4 |
| 19 | HCS 5/16" - 18 X 1" SS | H-70055 | 2 |
| 20 | Nylok 1/4" -20 SS | H-70860 | 3 |
| 21 | HCS 1/4"-20 X 1" SS | H-70005 | 3 |
| 22 | HB 5/16"-18 X 1 SS | H-70055 | 2 |
| 23 | HCS 3/8"-16 X 1" SS | H-70105 | 3 |
| 24 | Lockwasher 3/8 SS | H-71067 | 3 |
| 25 | RPH#10-32 X 3/4 SS | H-72565 | 2 |
| 26 | LW # 10 | H-33614 | 2 |

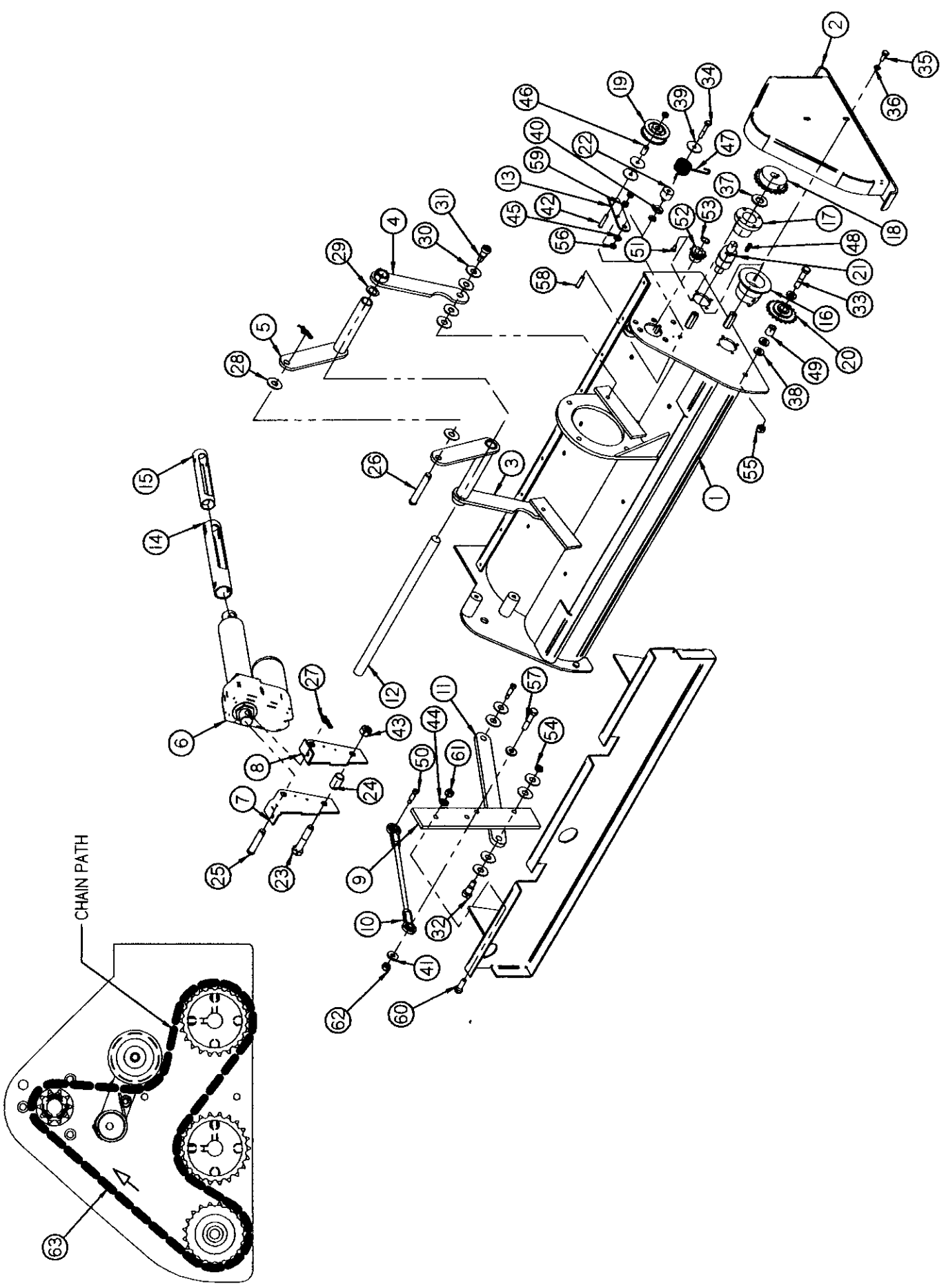

| Reference | DESCRIPTION | Part No. | Qty Req'd. |
|--------------------------------------------------------|-----------------------------------------------------------------------------------------------|----------|------------|
| SCRUB DECK PARTS: For Cylindrical Machines Only | | | |
| FIRST PAGE (continued) | | | |
| 27 | Cylindrical Scrub Brush <i>Chose to suit application: from softest to most aggressive:</i> | | 2 |
| | Tampico (Tan) | 5-521T | |
| | Soft nylon (White) | 5-521N | |
| | Light Grit (Grey) | 5-521PS | |
| | Mid Grit (Blue) | 5-521C | |
| | Tough Grit (Green) (formerly 5-521G) | 5-521S | |
| 28 | BH SCHS 3/8-16 X 1" SS | H-73815 | 1 |
| 29 | Idler Shaft | 5-858 | 1 |
| 30 | FW 17mm Nylon | H-17002 | 6 |
| 31 | Idler Bearing | 1-421 | 2 |
| 32 | Brush Idler | 5-838 | 2 |
| 33 | 17 mm Snap Ring | H-35313 | 2 |
| 34 | Wingnut 5/16" -18 SS | H-70911 | 3 |
| 35 | LW 5/16" SS | H-71065 | 3 |
| 36 | FHP 1/4" - 20 X 1" | H-72710 | 3 |
| 37 | Hopper Handle | 5-849 | 2 |
| 38 | HN 1/4"-20 SS | H-70710 | 9 |
| 39 | LW 1/4" SS | H-71063 | 9 |
| 40 & 41 | Key 3/16" X 3/4" long | H-00270 | 2 |

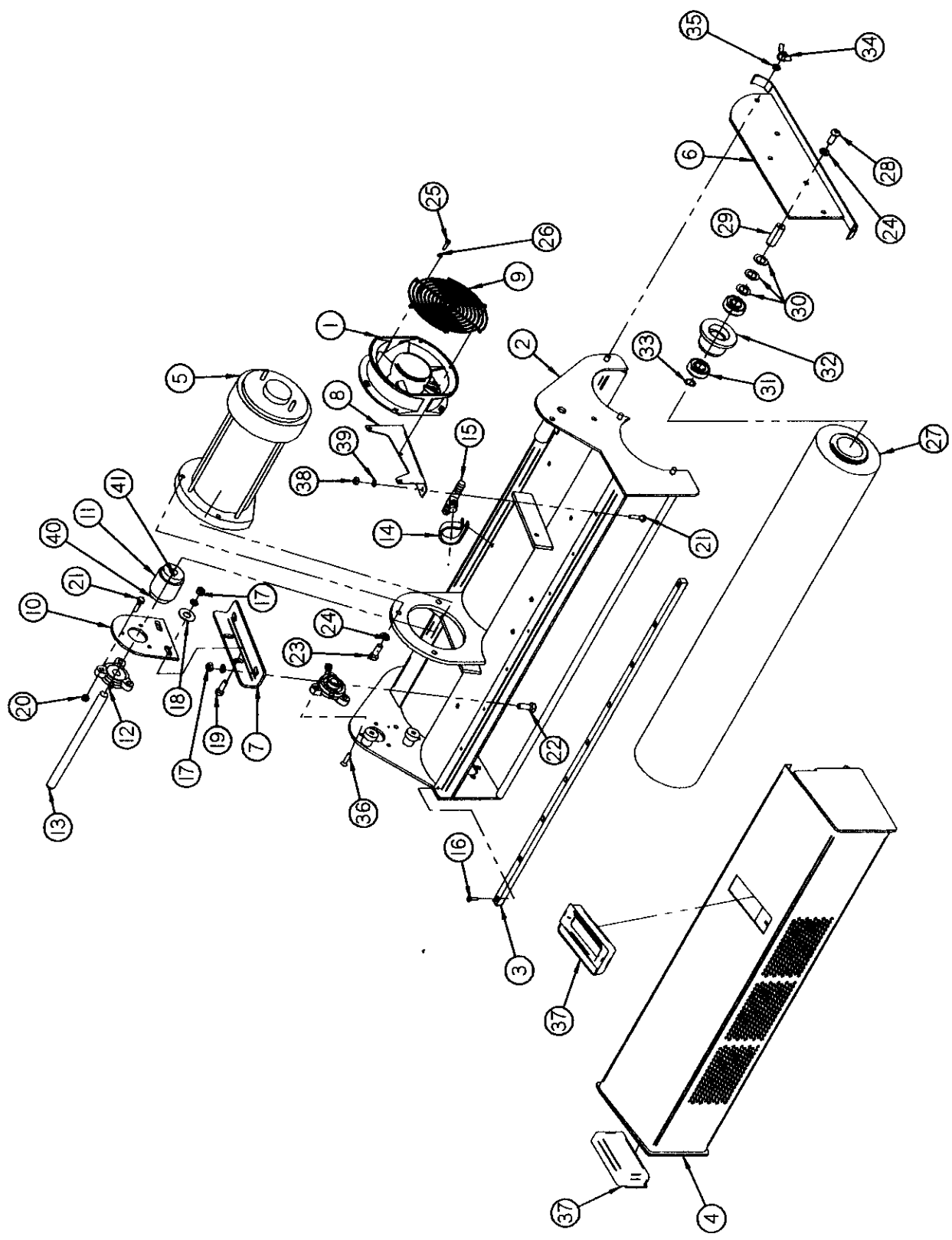

| Reference | DESCRIPTION | Part No. | Qty Req'd. |
|--------------------------------------------------------|-------------------------------------------------------|----------|------------|
| SCRUB DECK PARTS: For Cylindrical Machines Only | | | |
| Second Page | | | |
| 1 | Cylindrical body | 5-800 | 1 |
| 2 | Chain Guard Plastic (Old Style) | 5-845 | 1 |
| | Chain Guard Steel with integral steel ski (New Style) | 5-9021 | 1 |
| Not illustrated | Chain Guard Seal (Sold by the foot) | 5-845A | 2 feet |
| 3 | Left Lower Link | 5-804 | 1 |
| 4 | Right Lower Link | 5-805 | 1 |
| 5 | Upper Link | 5-803 | 2 |
| 6 | Actuator | 5-221 | 1 |
| 7 | Right Actuator Adapter | 5-806 | 1 |
| 8 | Left Actuator Adapter | 5-807 | 1 |
| 9 | Forward Link Mount | 5-810 | 2 |
| 10 | Adjustable Link | 5-843 | 2 |
| 11 | Lower Parallel Arm; Set of 2 arms | 5-809 | 1 set of 2 |
| 12 | Shaft, 3/4" X 15" | 5-840 | 1 |
| 13 | Movable Chain Idler Arm | 5-797 | 1 |
| 14 | Spring Tube, Outer (replaces old 5-841) | 5-1101 | 1 |
| 15 | Spring Tube, Inner (replaces old 5-841) | 5-1102 | 1 |
| 16 | Cylindrical Brush Driver | 5-837 | 2 |
| 17 | Drive Bearing Housing | 1-305 | 2 |
| 18 | 22 Tooth Sprocket | 5-828 | 2 |
| 19 | Idler Pulley W/Bearing | 4-317 | 1 |
| 20 | Fixed Idler Sprocket w/ bearing (20 tooth) | 5-827 | 1 |
| 21 | Brush Driver Bearing | 5-824 | 2 |
| 22 | Idler Spacer (.687 dia., .375 OD, .25 ID) | 5-822 | 1 |
| 23 | HCS 1/2-13 X 2.5" | H-13213 | 2 |
| 24 | Spacer (.75 OD X .625 ID X 1.125 Wide) | 5-821 | 1 |
| 25 | Clevis Pin 1/2 X 2.25" | 5-509 | 1 |
| 26 | Clevis Pin 1/2" X 3" | 5-405 | 2 |
| 27 | 1/2" Rue Ring Cotter | H-RUE22 | 2 |
| 28 | Washer, PVC 3/4 ID | H-95611 | 4 |
| 29 | Washer, 3/4 ID Nylon | H-90295 | 4 |
| 30 | Washer, SS, 1/2" | H-71021 | 12 |
| 31 | Shoulder Bolt, 1/2" SS | H-25452 | 2 |
| 32 | Shoulder Bolt, 3/8" SS | 7-412A | 2 |

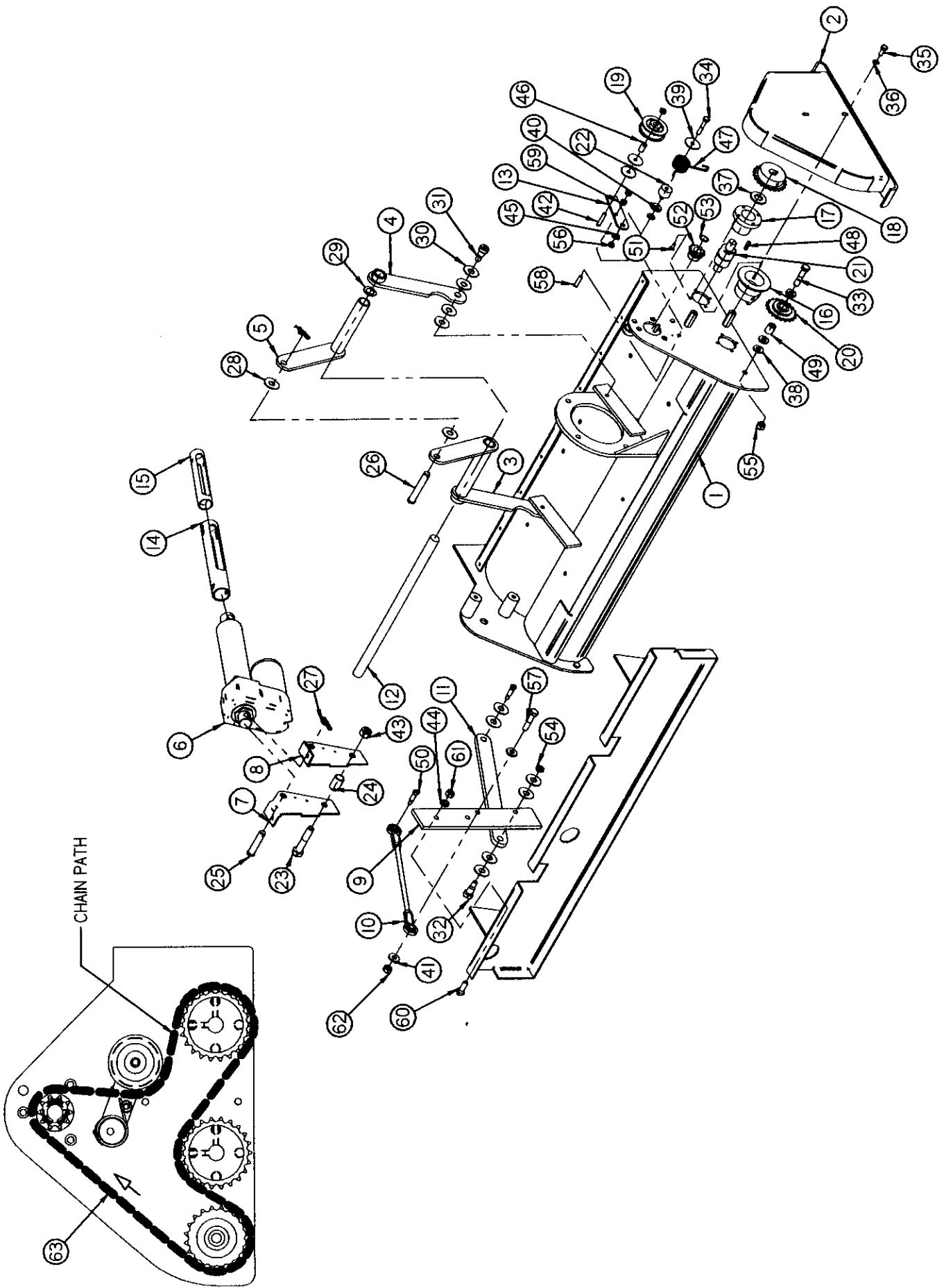

| Reference | DESCRIPTION | Part No. | Qty Req'd. |
|--------------------------------------------------------|-------------------------------------------------------------------|----------|------------|
| SCRUB DECK PARTS: For Cylindrical Machines Only | | | |
| Second Page (continued) | | | |
| 33 | Bolt HCS 3/8-24 X 1.75" SS | H-70145 | 1 |
| 34 | Shoulder Bolt, 3/8" SS | 7-412A | 1 |
| 35 | HCS 1/4-20 X 3/4" SS | H-70003 | 2 |
| 36 | LW 1/4 SS | H-71063 | 2 |
| 37 | Washer, Teflon 5/8" | H-00279 | 2 |
| 38 | Washer 3/8 Grade 8 | H-98025 | 3 |
| 39 | FW 1/4 X 1-1/4 | H-33208 | 1 |
| 40 | Washer, Nylon 3/8" | H-76063 | 2 |
| 41 | Washer Grade 8 3/8" | H-98025 | 4 |
| 42 | SCS 1/4"-20 X 1 1/4" | H-93580 | 1 |
| 43 | Nut, Nyllok 1/2-13 SS | H-37030 | 1 |
| 44 | LW 1/4" | H-71063 | 4 |
| 45 | FW 3/8 Nylon | H-76063 | 4 |
| 46 | Pulley Spacer | 5-822 | 1 |
| 47 | Tension Spring | 4-319 | 1 |
| 48 | Key, 3/16 X 1/2" | H-K1432 | 2 |
| 49 | Idler Spacer | 5-793 | 1 |
| 50 | HCS 3/8-16 X 1" SS | H-70105 | 4 |
| 51 | FHP 10-32 X 1/2" SS | H-72682 | 8 |
| 52 | 10 Tooth Sprocket | 5-826 | 1 |
| 53 | Snap Ring 5/8 | H-68013 | 1 |
| 54 | Nut, Nyllok 5/16 SS | H-70861 | 1 |
| 55 | HN 3/8-24 SS | H-70732 | 1 |
| 56 | Jam Nyllok Nut | H-NJ04C | 1 |
| 57 | HCS 3/8-24 X 1.75 SS | H-70145 | 2 |
| 58 | Self Clinch Stud 1/4-20 X 1 | H-00272 | 1 |
| 59 | HN 1/4-20 SS | H-70710 | 13 |
| 60 | HCS 3/8-16 X 1" SS | H-70105 | 2 |
| 61 | FHN 3/8-16 SS | H-36306 | 4 |
| 62 | FHN 3/8-24 | H-70732 | 2 |
| Not Illustrated | Lockwasher 3/8 (Fits under item 62) | H-71067 | 2 |
| 63 | Chain | 5-830 | 1 |
| | Master Link | 5-831 | 1 |
| | Half Link | 5-830A | 1 |
| Not Illustrated | Cylindrical Drive Teflon Grease; Factory Cat Hi-Pressure Lube # 1 | 5-796 | 1 |

SIDEBROOM

OPTION

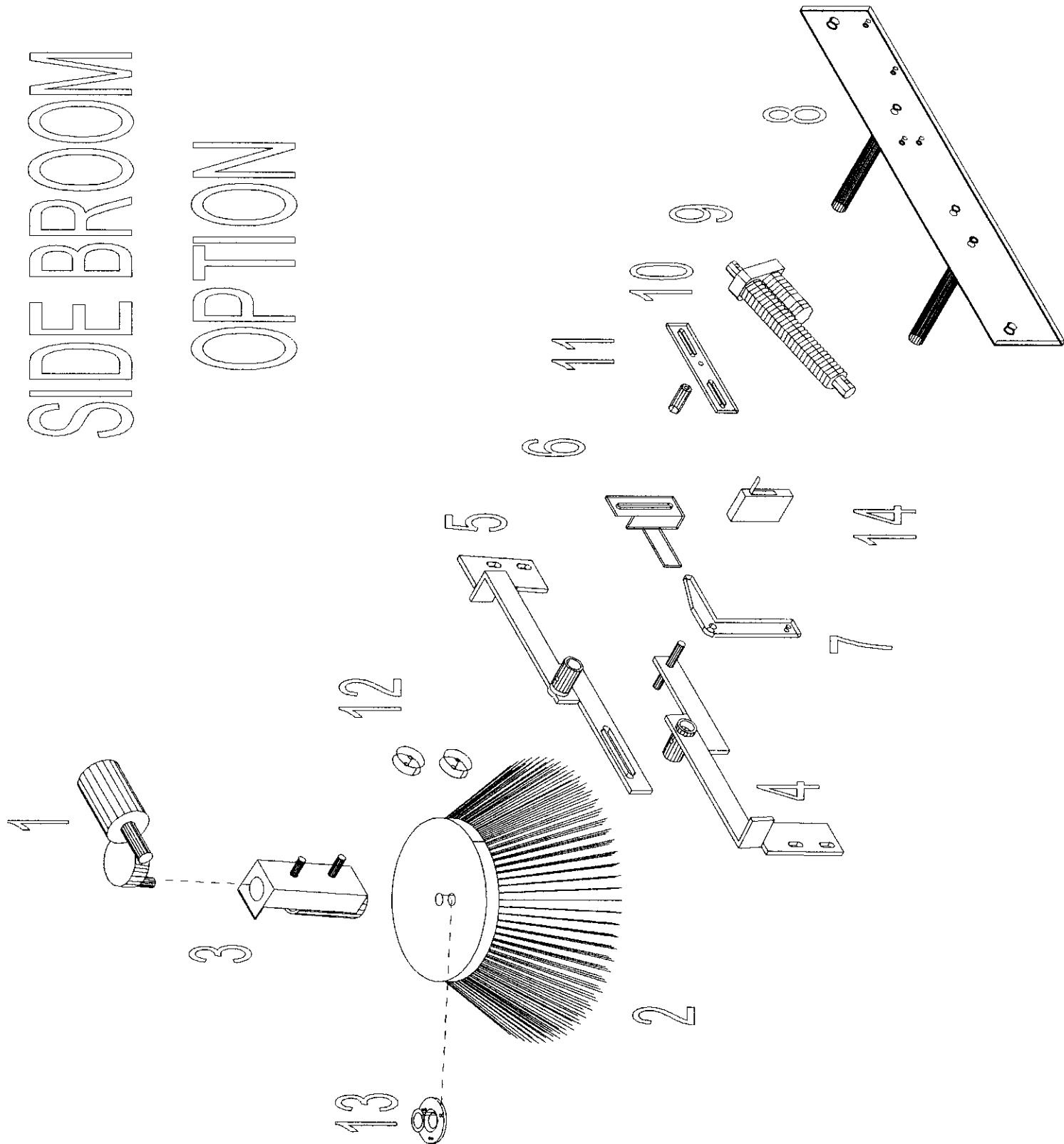

| Reference | DESCRIPTION | Part No. | Qty Req'd. |
|-----------------|------------------------------------------------------------------------------------------------------------------------------------------------------------------------------------|----------|------------|
| | SIDE BROOM SYSTEM | | |
| | <i>Available as Option on Cylindrical-Brush System Equipped Units Only</i> | | |
| | Sidebroom System Complete (Optional) | 5-814 | 1 Opt. |
| 1 | Side Broom Motor, 24V | 8-220 | 2 |
| 2 | Side Broom | | 2 |
| | | 4-402 | |
| | | 4-402N | |
| 3 | Side broom Drive Tube with Bearings, & Shaft | 4-445 | 2 |
| | <i>On new machines, shorter tube system than old with better ground clearance. new style fits all However, you must order short drive tube and short shaft in combination.</i> | | |
| | Side Broom Drive Tube (short) | 5-875 | 2 |
| | Shaft (short) | 5-876 | 2 |
| | Bearing | 4-445C | 4 |
| 4 | Broom Arm, Lefthand | 5-437 | 1 |
| 5 | Broom Arm, Righthand | 5-438 | 1 |
| 6 | Cylindrical Sidebroom Stop Set | 5-818 | 1 |
| 7 | Bell Crank | 5-820 | 1 |
| 8 | Plate | 5-819 | 1 |
| 9 | Actuator | 7-224 | 1 |
| 10 | Actuator Adjustment Slide | 5-817 | 1 |
| 11 | Actuator Slide Standoff | H-92230 | 1 |
| 12 | Sidebroom Shock Mount | 4-446 | 4 |
| 13 | Sidebroom Clutch Plate | 4-404 | 2 |
| | Sidebroom Clevis Pin (with keeper) | 4-403 | 2 |
| 14 | Micro Switch (used on early machines) | 7-820 | 1 |
| Not Illustrated | Diode bridge (Used instead of 7-821 after 5/2000) | 5-296 | 1 |
| Not Illustrated | Toggle Switch DPDT (on/off/on); Mounts on steering column | 7-821 | 1 |
| Not Illustrated | Wire harness, Complete Old Style Uses Omron switch | 5-307 | 1 |
| Not Illustrated | Wire harness, Complete New Style; uses Diode Bridge | 5-308 | 1 |

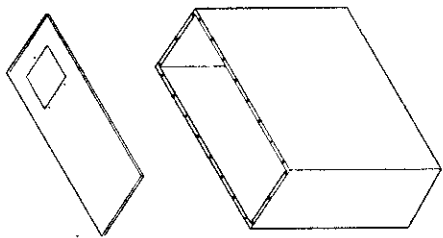

SOLUTION PLUMBING SYSTEM
BEFORE HF40-3100

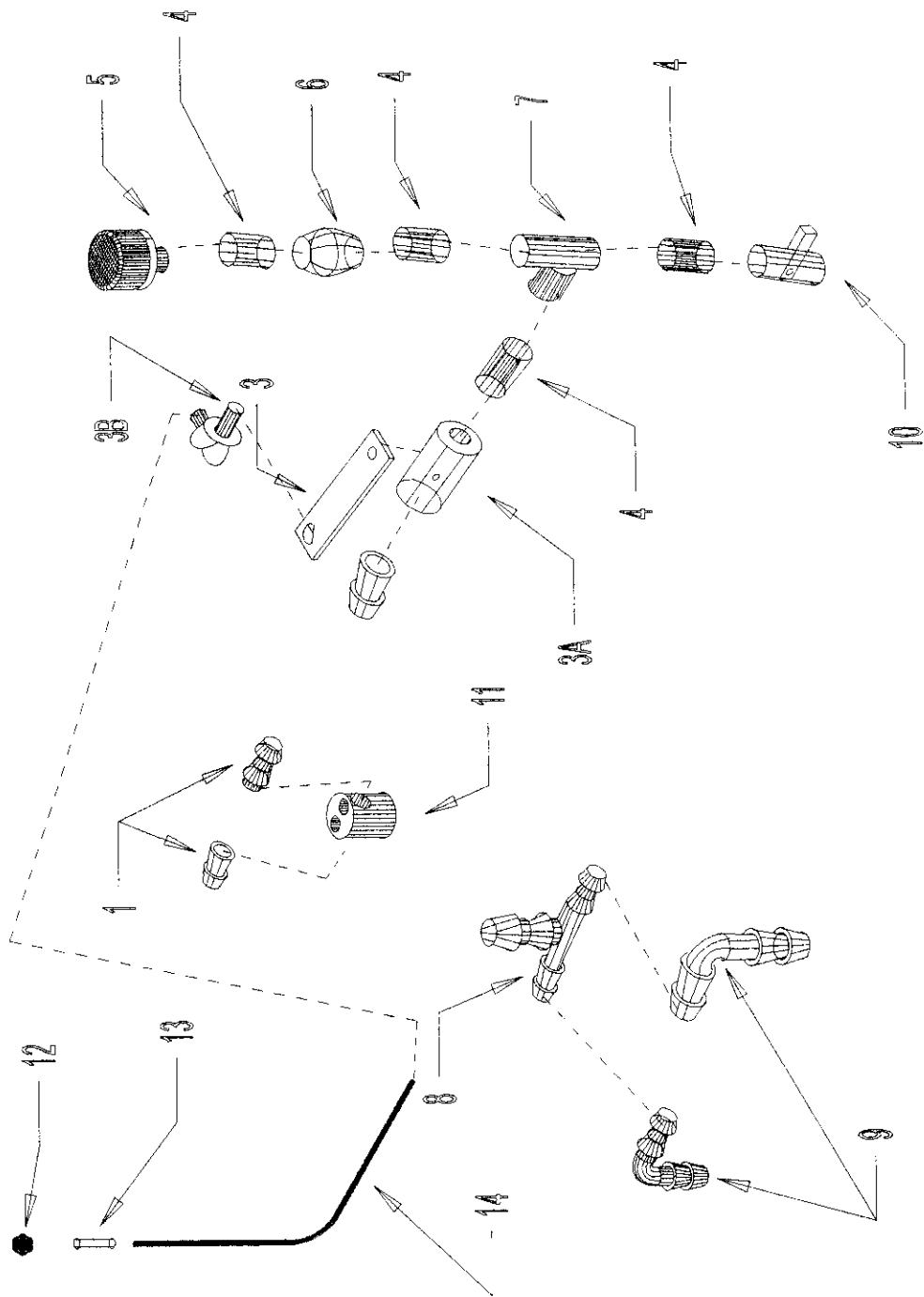

| Reference | DESCRIPTION | Part No. | Qty Req'd. |
|--------------------------------------------------------------------|---------------------------------------------------------------------|----------|--------------|
| SOLUTION PLUMBING SYSTEM, UNITS BEFORE Serial No. HF40-3100 | | | |
| 1 | Plastic Barb Fitting: 3/8" NPT to 1/2" barb | 5-441R | 2 |
| 2 | Plastic Barb Fitting: 3/4" NPT to 1/2" barb | 5-441A | 1 |
| 3 | Flow Control Gate Lever | 5-439 | 1 |
| 3A | Flow Control Gate Valve | 5-445B | 1 |
| 3B | Threaded End Fitting and Link (not shown) | 8-453A | 1 |
| 4 | Steel Nipple, 3/4" NPT | 5-442 | 4 |
| 5 | Solution Intake Screen | 5-415 | 1 |
| 6 | Steel Union, 3/4" NPT | 5-444 | 1 |
| 7 | Steel Tee, 3/4" NPT | 5-443 | 1 |
| 8 | 5/8" Plastic Barb Tee (goes to 18A on scrub deck page) | 7-247 | 1 |
| 8A | 1/2" Plastic Barb Tee (goes to 18A on scrub deck page) | 5-446 | 1 |
| 9 | Plastic Water Jet Elbow: 1/2" NPT to 1/2" Barb Elbow | 5-447 | 2 |
| 10 | Solution Tank Dump Valve | 5-445 | 1 |
| 11 | Solution Tank Electrovalve | 5-244 | 1 |
| 12 | Solution Flow Cable Knob | 5-451 | 1 |
| 13 | Solution Flow Cable Knob Mount | 5-449 | 1 |
| 13A | Solution Flow Cable Clip (not shown) | 5-448A | 1 |
| 14 | Solution Flow Control Cable | 5-448 | 1 |
| 15 | Nylon-Reinforced Hose (1/2" diameter) not shown | 5-440 | Sold by foot |
| 16 | Nylon-Reinforced Hose (5/8" diameter) not shown | 5-466 | Sold by Foot |
| Not Illustrated | Solution Tank, Complete for Model 40 HD (Stainless Steel) 52 Gallon | 5-401 | 1 |
| | Solution Tank Top | 5-410 | 1 on SS |
| | Solution Tank Gasket (Tank to top) | 5-400 | 1 on SS |
| | Solution Tank Fill Door | 5-411 | 1 |
| | Solution Tank Fill Door Gasket set of 2 | 5-412N | 1/2 of set |
| | Door Hinge | 5-413 | 1 |
| | Flush-Out Door Knob | 5-418 | 1 |
| | Flush-Out Door Clip | 5-417 | 1 |

SOLUTION PLUMBING SYSTEM HF 40-3100 & AFTER

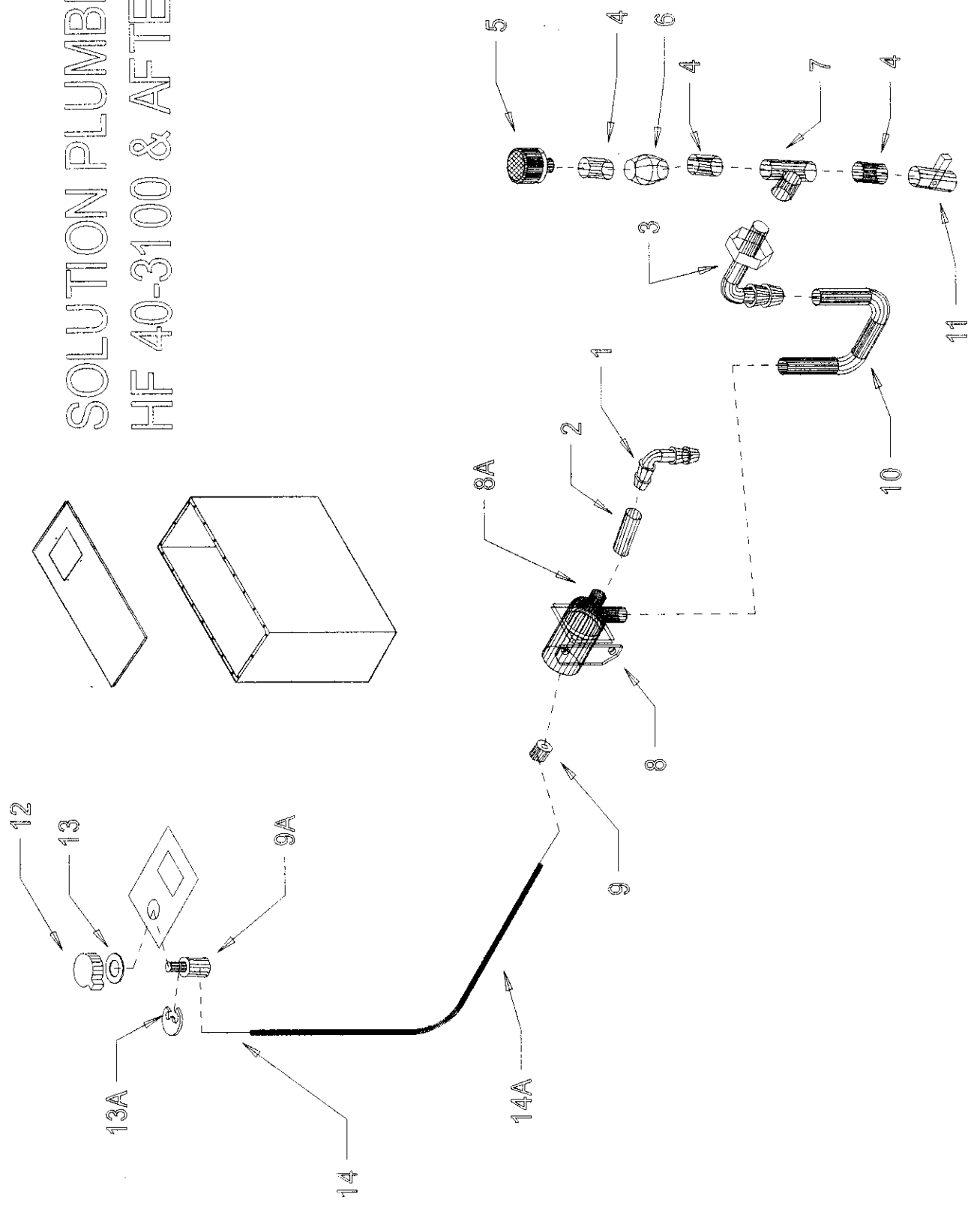

| Reference | DESCRIPTION | Part No. | Qty Req'd. |
|------------------------------------------------------------------|-------------------------------------------------------------------------------------|----------|------------|
| SOLUTION PLUMBING SYSTEM Serial No. HF40-3100 & AFTER | | | |
| 1 | 5/8 to 5/8 Barb Elbow | 5-459 | 1 |
| 2 | 5/8 Hose (valve to Barb Elbow) | 5-460 | 1 |
| 3 | 5/8 Barb to 3/4 NPT Elbow | 5-462 | 1 |
| 4 | Steel Nipple, 3/4" NPT | 5-442 | 3 |
| 5 | Solution Intake Screen (in tank) used on 50 gal tanks prior to 4/2000 | 5-415 | 1 |
| Not Illustrated | Solution Intake filter (under tank) all 70 gallon, and on 50 gallon starting 4/2000 | 5-913 | |
| 6 | Steel Union, 3/4" NPT | 5-444 | 1 |
| 7 | Side Outlet Tee (4 outlets) | 5-443A | 1 |
| 8 | Adjustable Solution Flow Valve | 7-245 | 1 |
| 8A | Polysulfone Face for Detroit valve | 7-245F | 1 |
| 9 | Solution Flow Lower Cable Coupler | 7-447 | 1 |
| 9A | Solution Flow Upper Cable Coupler | 7-446 | 1 |
| 10 | 5/8" Nylon Reinforced Hose (connects to 5/8" barb elbow to waterjet pump) | 5-461 | 1 |
| 11 | Solution Tank Dump Valve | 5-445 | 1 |
| 12 | Solution Flow Adjustment Knob | 7-451B | 1 |
| 13 | Washer | 7-451A | 1 |
| 13A | E Clip | 7-455 | 1 |
| 14 | Solution Flow Control Cable (inner core) | 5-467 | 1 |
| 14A | Solution Flow Cable (outer tubing) | 5-468 | 1 |
| 15 | Nylon Reinforced Hose (1/2" Diameter) Not Shown | 5-440 | 1 |
| 15A | Nylon Reinforced Hose (5/8" Diameter) Not Shown | 5-466 | 1 |
| 16 | Steel Tee, 3/4" NPT, old style (not shown) used before Serial HJ-XXXX | 5-443 | 1 |
| | Steel Tee, 3/4" NPT, New style (not shown) used on SN HJ-XXXX & after | 5-443A | 1 |
| Not Illustrated | Solution Tank, Complete for Model 40 (Polyethylene) | 5-687 | 1 |
| Not Illustrated | Solution Tank, Complete for Model 40 HD (Stainless Steel) 52 Gallon | 5-401 | 1 |
| Not Illustrated | Solution Tank Complete for Model 40HD (Stainless) 70 Gallon Capy | 5-914 | 1 Opt |
| | Solution Tank Top | 5-410 | 1 on SS |
| | Solution Tank Gasket (Tank to top) | 5-400 | 1 on SS |
| | Solution Tank Fill Door | 5-411 | 1 |
| | Solution Tank Fill Door Gasket set of 2 | 5-412N | 1/2 of set |
| | Door Hinge | 5-413 | 1 |
| | Flush-Out Door Knob | 5-418 | 1 |
| | Flush-Out Door Clip | 5-417 | 1 |

RECOVERY SYSTEM BEFORE HI40-3803

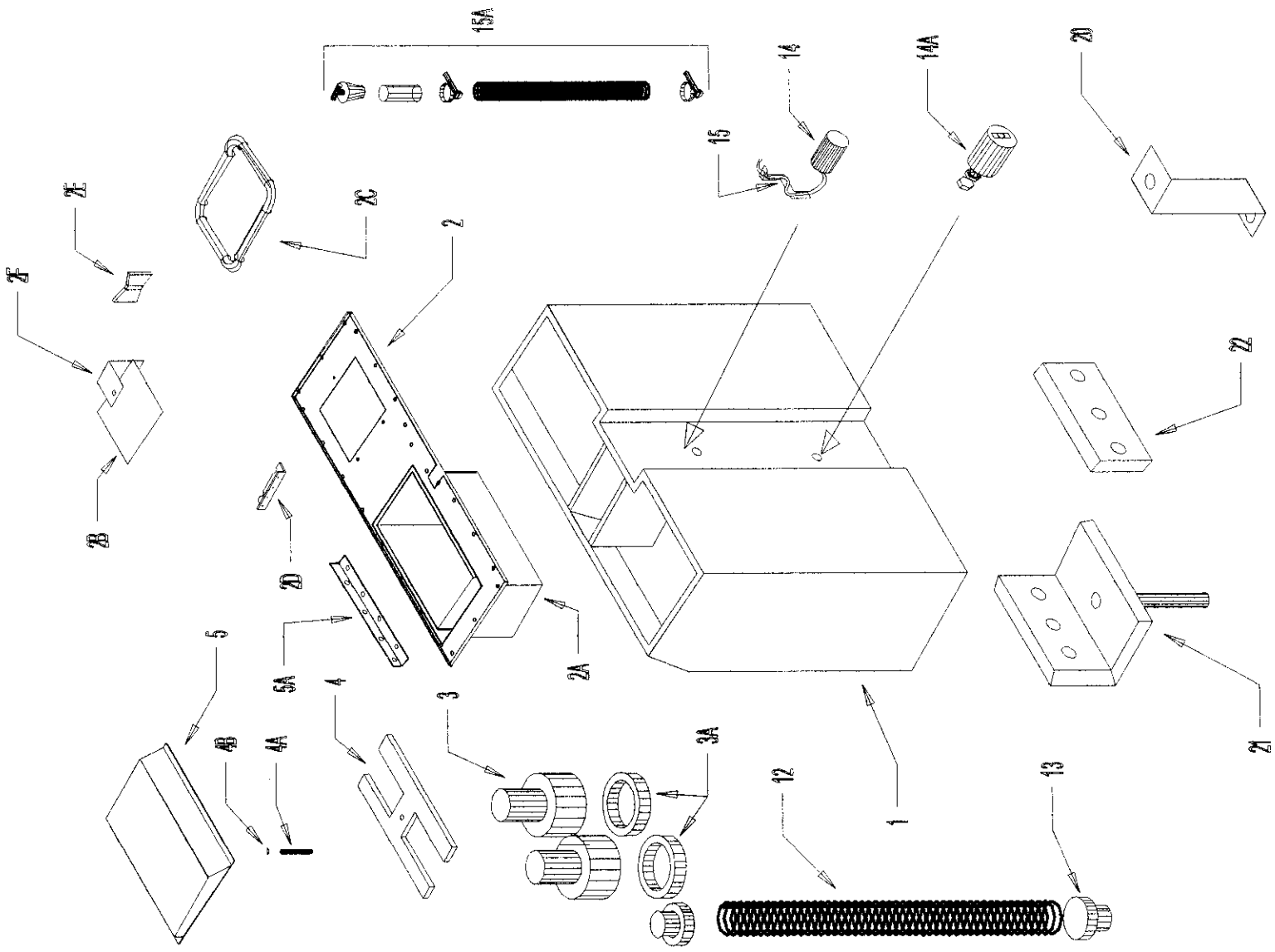
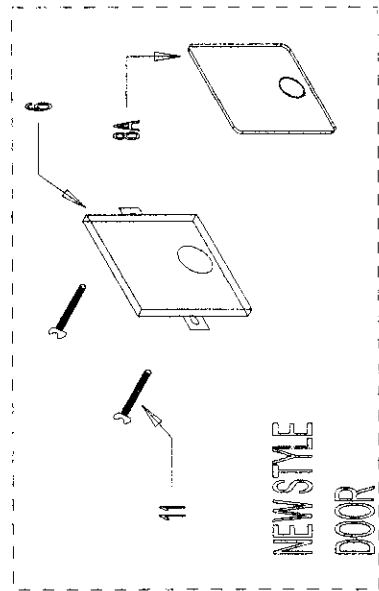
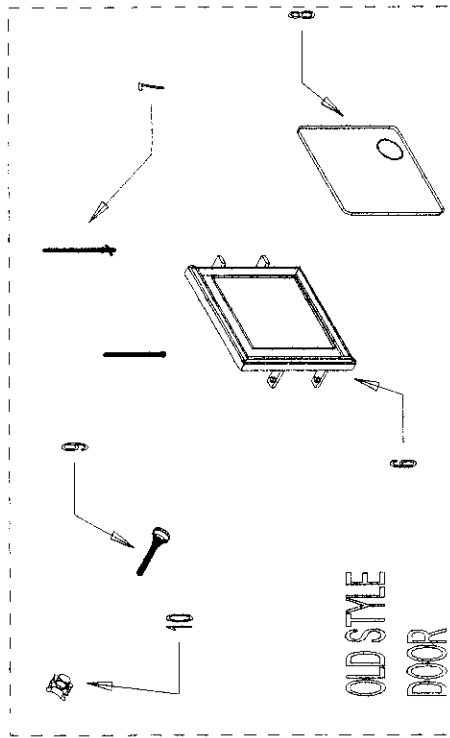

RECOVERY SYSTEM BEFORE HI40-3803

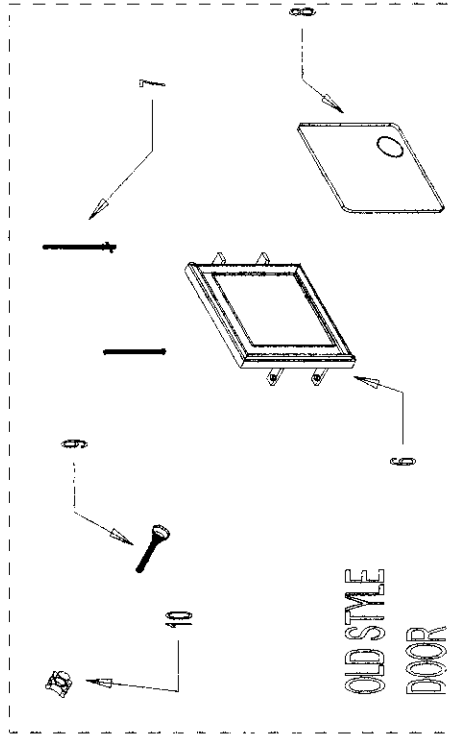

OLD STYLE
DOOR

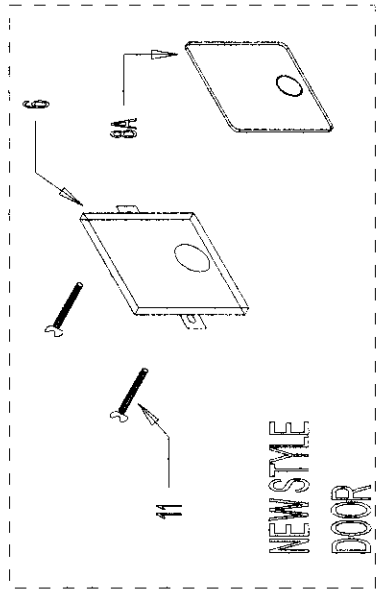

NEW STYLE
DOOR

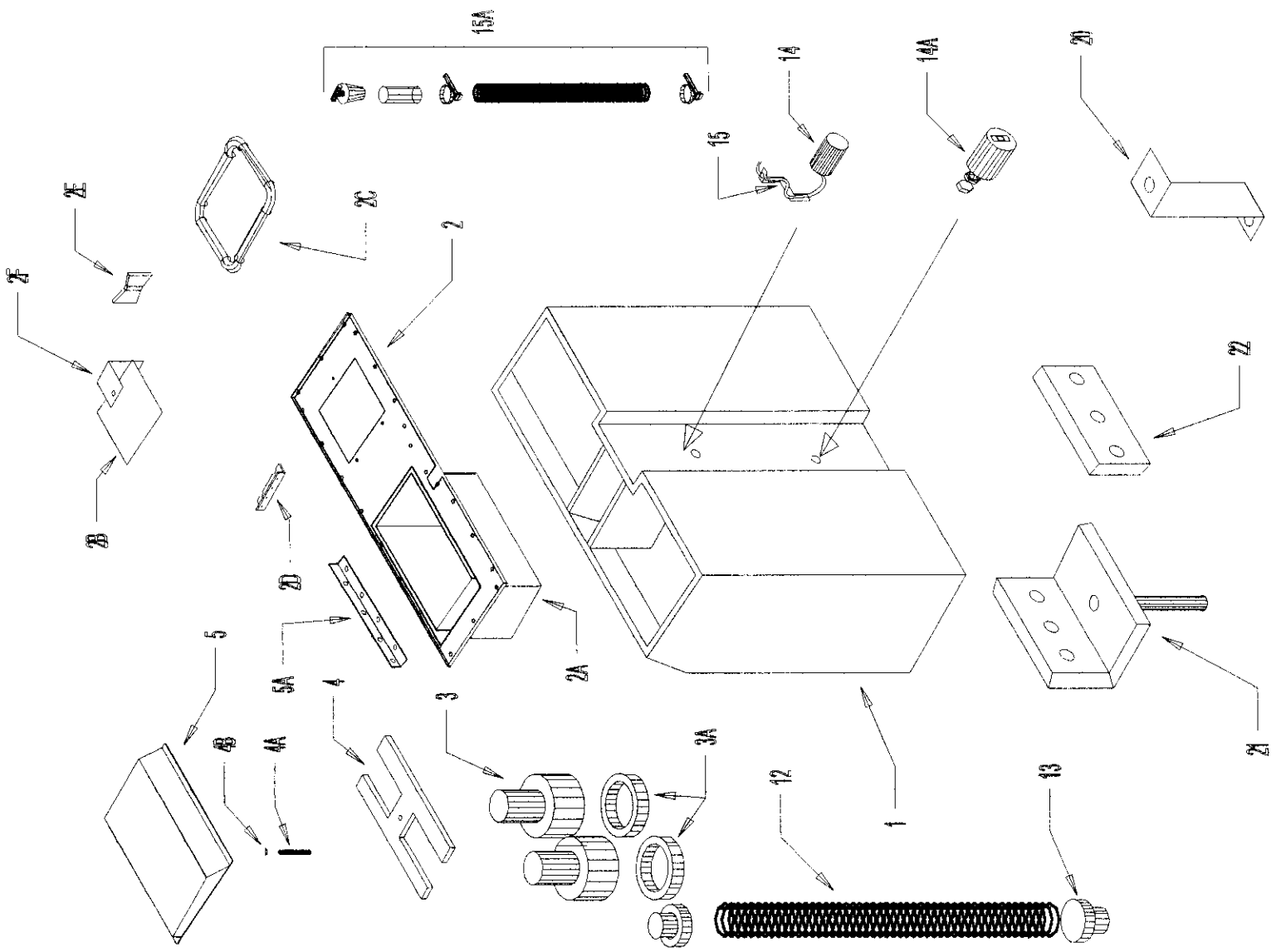

| Reference | DESCRIPTION | Part No. | Qty Req'd. |
|-----------------|---------------------------------------------------------------------------------------------|--------------|------------|
| | RECOVERY SYSTEM BEFORE HI40-3803 (Electric vac motor shutoff) | | |
| | <i>Note Old system uses different tank top, and features electric shutoff of vac motors</i> | | |
| | <i>New Style uses "pingpong ball" shutoff. Update Kit K-106 updates old style to new</i> | | |
| 1 | Recovery Tank, stainless steel | 5-701 | 1 |
| 2 | Top For Recovery Tank, stainless steel | 5-707 | 1 |
| | <i>NOTE Update Kit K-106 converts old style tank to new style system, costs less!</i> | K-106 | update |
| | Gasket for Top | 5-694 | 1 |
| 2B | Flush-Out Door | 5-411 | 1 |
| 2C | Flush-Out Door Gasket (new style) | 5-412N | 1 |
| 2D | Flush-Out Door Hinge | 5-413 | 1 |
| 2E | Flush-Out Door Knob | 5-418 | 1 |
| 2F | Flush-Out Door Clip | 5-417 | 1 |
| 3 | Vac Motor, complete with gasket | 5-225 | 2 |
| 3A | Vac Motor Gasket | 5-708 | 2 |
| 4 | Vac Motor Hold Down Clamp Set | 5-710 | 1 Set |
| | Vac Motor Hold Down Bolt Set (includes 13 & 14) | 5-711 | 1 Set |
| 4A | Hold Down Bracket Stud | 5-710A | 1 |
| 4B | Wing Nut | H-70910 | 1 |
| 5 | Vac Motor Compartment Door | 5-713 | 1 |
| 5A | Vac Motor Compartment Door Hinge | 5-712 | 1 |
| | Cleanout Door System For units built prior to March, 1997 | | |
| 6 | Cleanout Door Set NOT CURRENT | Call Factory | |
| 7 | Cleanout Door Release Pin | NSS | 1 |
| 8 | Cleanout Door Gasket (new style) | NSS | 1 |
| 9 | Cleanout Door Rod | NSS | 1 |
| 10 | Cleanout Door Knob | NSS | 1 |
| | Cleanout Door System for Current Units (After 3/97) | | |
| | Cleanout Door Set | 5-702B | 1 |
| 6 | Cleanout door | NSS | 1 |
| 8 | Gasket | 5-703 | 1 |
| 11 | Wingbolt | 5-715 | 2 |
| Not illustrated | O-Ring --retains wingbolt | 5-715A | 2 |
| 12 | Vac Hose, complete | 5-705 | 1 |
| 13 | Cuff for vac hose | 5-706 | 2 |
| 14 | Float Switch (turns vac motors off when tank is full) | 5-226 | 1 |
| 14A | Float Switch (tank warming light) | 5-226 | 1 |

| | | | |
|-----------------|----------------------------------------------------------|-------|---|
| 15 | Float Switch Mount (Stainless steel) | 5-729 | 1 |
| 15A | Drain Hose Assembly: complete | 5-730 | 1 |
| | Drain Hose Plug | 5-727 | 1 |
| | Drain Hose | 5-721 | 1 |
| | Drain Hose Clamp | 5-719 | 2 |
| | Drain Hose End Tube (stainless steel) | 5-720 | 1 |
| Not Illustrated | Tank Tie Down Strap, complete | 5-722 | 1 |
| | Tank Tie Down Strap Hook | 5-723 | 1 |
| 21 | Tank Tie-Down Strap Belt Attachment, rear | 5-724 | 1 |
| 22 | Tank Tie-Down Strap Belt Attachment, front | 5-725 | 1 |
| | Tank Tie-Down Strap Belt (polypropylene weave) not shown | 5-726 | 1 |

RECOVERY SYSTEM HI40-3803 & AFTER

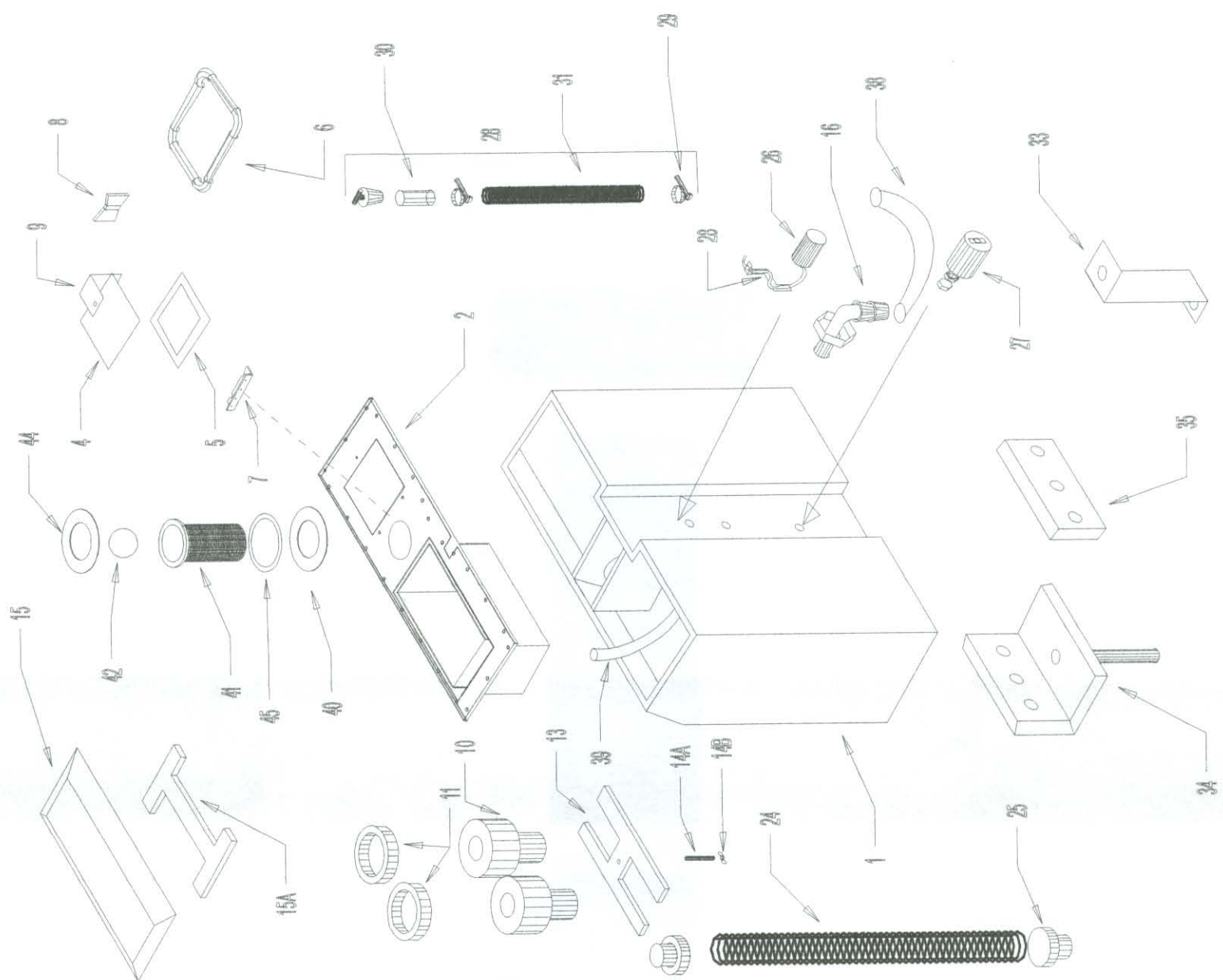
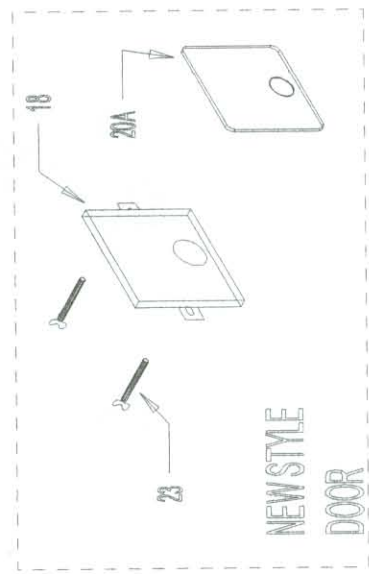
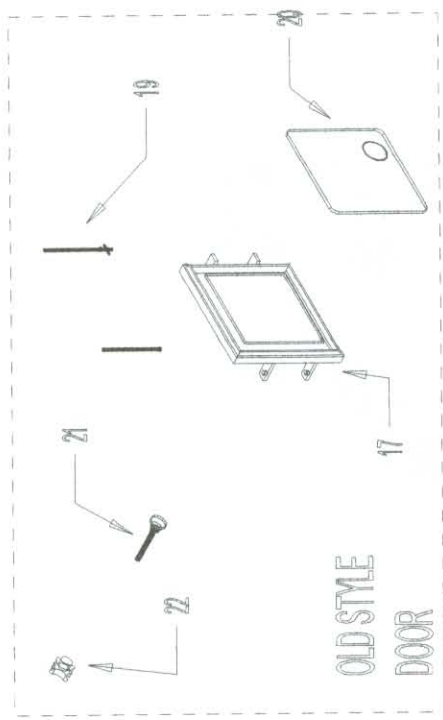

| Reference | DESCRIPTION | Part No. | Qty Req'd. |
|------------------------|--------------------------------------------------------------------------|----------|------------|
| RECOVERY | SYSTEM HI40-3803 & AFTER | Part No. | Qty Req'd. |
| 1 | Recovery Tank, stainless steel 55 Gallon Capacity (Standard; 40 HD only) | 5-699 | 1 |
| | 70 Gallon Recovery Tank (Optional on 40 HD Only) | 5-915 | 1 Opt |
| | Recovery Tank, poly, 50 gallon capacity (Model 40) | 5-689 | 1 |
| 2 | Top For Recovery Tank, stainless steel (HD Only) | 5-700 | 1 |
| <i>Not illustrated</i> | Gasket top.-to-tank. | 5-694 | 1 |
| 3 | 1/2" Female NPT to 1/2" Barb (not shown) | 5-695 | 1 |
| 4 | Flush-Out Door Stainless steel tanks | 5-411 | 1 |
| | Flush-Out Door, Poly Tank (Clear "porthole") (includes mounting ring) | 7-425 | 1 |
| | Mounting gasket | 7-426 | 1 |
| 6 | Flush-Out Door Gasket: Fits all Stainless steel tanks Set of 2 | 5-412N | 1 set of 2 |
| 7 | Flush-Out Door Hinge Stainless steel tanks | 5-413 | 1 |
| 8 | Flush-Out Door Knob (Stainless steel tanks) | 5-418 | 1 |
| 9 | Flush-Out Door Clip (Stainless steel tanks) | 5-417 | 1 |
| 10 | Vacuum Motor | 5-250 | 2 |
| 11 | Vac Motor Gasket (one gasket) | 5-708A | 2 |
| 13 | Vac Motor Hold Down Clamp Set . Stainless tank dual vac motor units only | 5-710 | 1 Set |
| 14A&B | Vac Motor Hold Down Bolt Set | 5-711 | 1 Set |
| 14A | Hold Down Bracket Stud | 5-710A | 1 |
| 14B | Wing Nut | H-70910 | 1 |
| 15 | Vac Motor Compartment Door, Poly (for Model 40) | 5-688 | 1 on 40 |
| | Vac Motor Compartment Cover (upper Section) Stainless steel tanks | 5-697 | 1 on 40 HD |
| 15A | Vac Motor Compartment Cover (lower Section) Stainless steel tanks | 5-698 | 1 on 40 HD |
| 16 | Elbow, vac box drain system | 5-695 | 1 |
| 18 | Cleanout Door (Model 40 HD Stainless Steel Tank only) | 5-702B | 1 |
| | Cleanout Door (Model 40; Poly tank) with gasket 7-416 | 7-415 | 1 |
| 20A | Cleanout Door Gasket (Stainless Steel Tank only) | 5-703 | 1 |
| | Cleanout Door Gasket (Poly tank) | 7-416 | 1 |
| | Cleanout Door Gasket Stainless STEEL Tanks | 5-703 | 1 |
| 23 | 5/16"-.18 x 3" Wing Bolts | 5-715 | 2 |
| | O'Rings to retain wingbolts | 5-715A | 2 |
| 24 | Vac Hose with Cuffs: 70 Gal Stainless Steel Tank only | 5-705B | 1 |
| | Vac Hose with Cuffs: 55 Gal Stainless Steel Tank Only | 5-705 | 1 |

RECOVERY SYSTEM HI40-3803 & AFTER

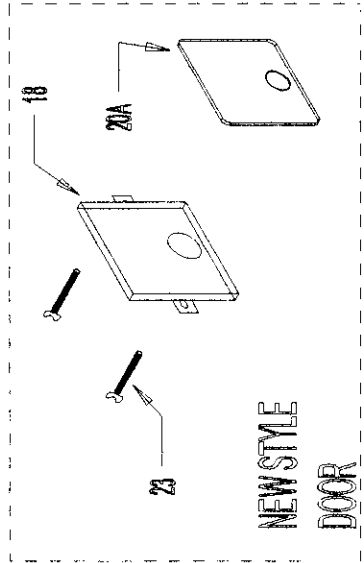
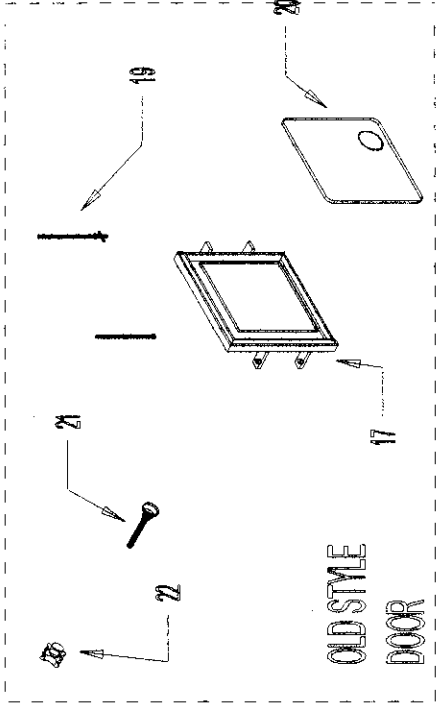
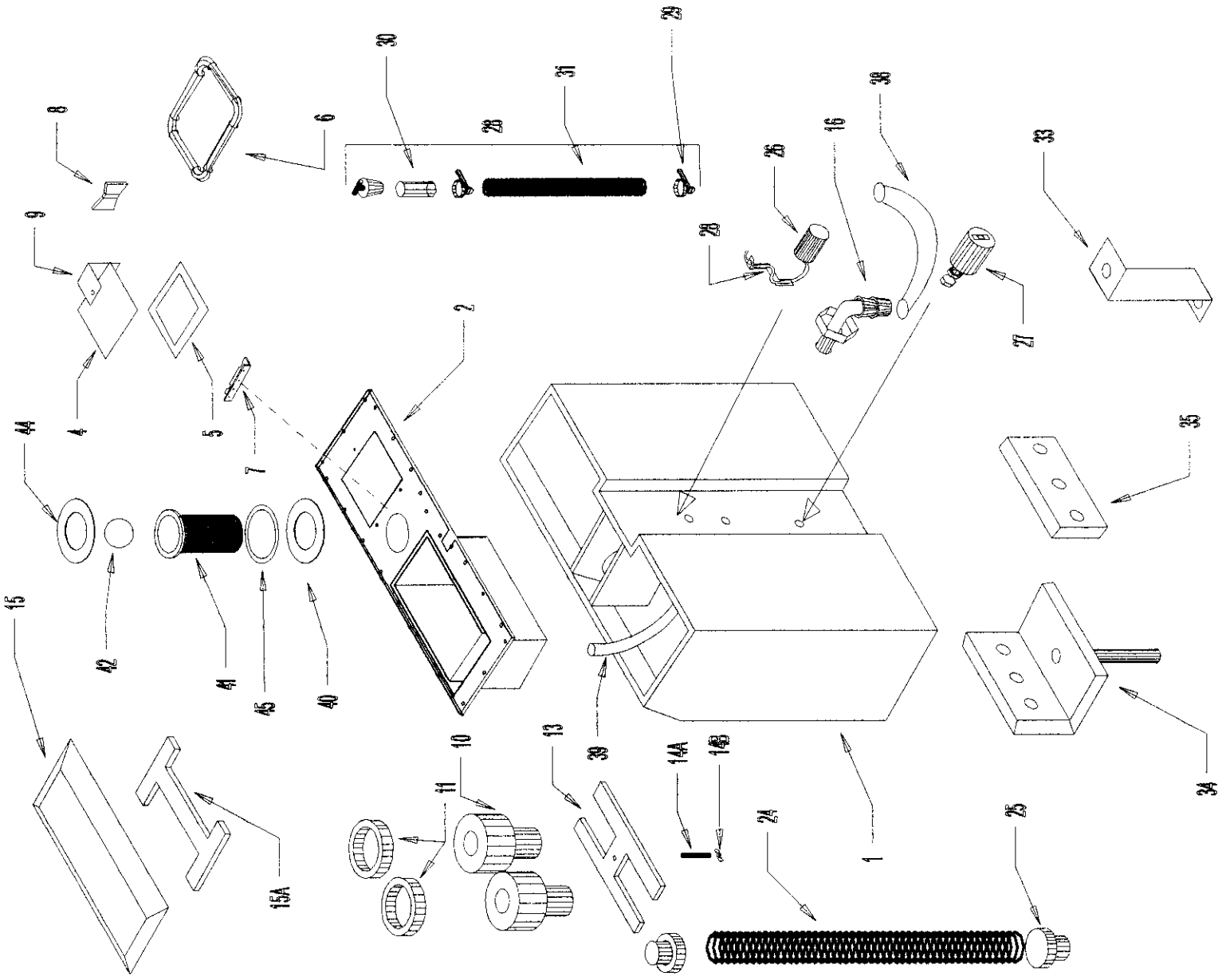

| Reference | DESCRIPTION | Part No. | Qty Req'd. |
|-----------------|-----------------------------------------------------------------|----------|------------|
| | RECOVERY SYSTEM H140-3803 & AFTER (Continued) | | |
| 24 | Vac Hose with Cuffs: 50 Gal Poly Tank Only | 38-741 | 1 |
| 25 | 1.5" to 2" | 38-740 | 1 |
| 25 | 1.5" to 1.5" | 7-710 | 1 |
| 28 | Drain Hose Assembly: complete for Poly Tank & 55 Gal SS Tank | 5-730 | 1 |
| 29 | Hose Clamp | 5-719 | 2 |
| 30 | Drain Hose End Tube for Poly Tank and 55 gal stainless steel | 5-720 | 1 |
| 31 | Drain Hose | 5-721 | 1 |
| Not Illustrated | Drain Hose Plug | 5-727 | 1 |
| 28 | Drain Hose Assembly: complete for 70 Gal Stainless Steel Tank | 5-730A | 1 |
| 29 | Hose Clamp | 5-719 | 2 |
| 30 | Drain Hose End Tube for Poly Tank and 55 gal stainless steel | 5-920 | 1 |
| 31 | Drain Hose | 5-721 | 1 |
| Not Illustrated | Drain Hose Plug | 5-727 | 1 |
| Not Illustrated | Tank Tie Down Strap, complete for 50 gal poly & 55 Gal SS Tanks | 5-722 | 1 |
| 33 | Tank Tie Down Strap Hook | 5-723 | 1 |
| 34 | Tank Tie-Down Strap Belt Attachment, rear | 5-724 | 1 |
| 35 | Tank Tie-Down Strap Belt Attachment, front | 5-725 | 1 |
| Not Illustrated | Tank Tie-Down Strap Belt (polypropylene weave) not shown | 5-726B | 1 |
| Not Illustrated | Tank Tie-Down Strap, complete for 70 gal SS Tank | 5-722B | optional |
| 33 | Tank Tie Down Strap Hook | 5-723 | 1 |
| 34 | Tank Tie-Down Strap Belt Attachment, rear | 5-724 | 1 |
| 35 | Tank Tie-Down Strap Belt Attachment, front | 5-725 | 1 |
| Not Illustrated | Tank Tie-Down Strap Belt (polypropylene weave) not shown | 5-726B | 1 |
| 38 | Vac Box Drain Hose (lower half) (Stainless tanks only) | 5-692 | 1 |
| 39 | Vac Box Drain Hose (upper half) (Stainless tanks only) | 5-696 | 1 |
| 40 | Vac Box Filter Screen Gasket | 38-738 | 1 |
| 41 | Filter Screen | 8-911 | 1 |
| 42 | Overflow Shutoff Ball | 38-712 | 1 |
| Not Illustrated | Vac Box Drain Hose Washer Set (stainless tanks only) | 5-693 | 1 set |
| Not Illustrated | Vac Cover Gasket (Goes between tank and top) SS tanks only | 38-739 | 1 |

SQUEEGEE LIFT

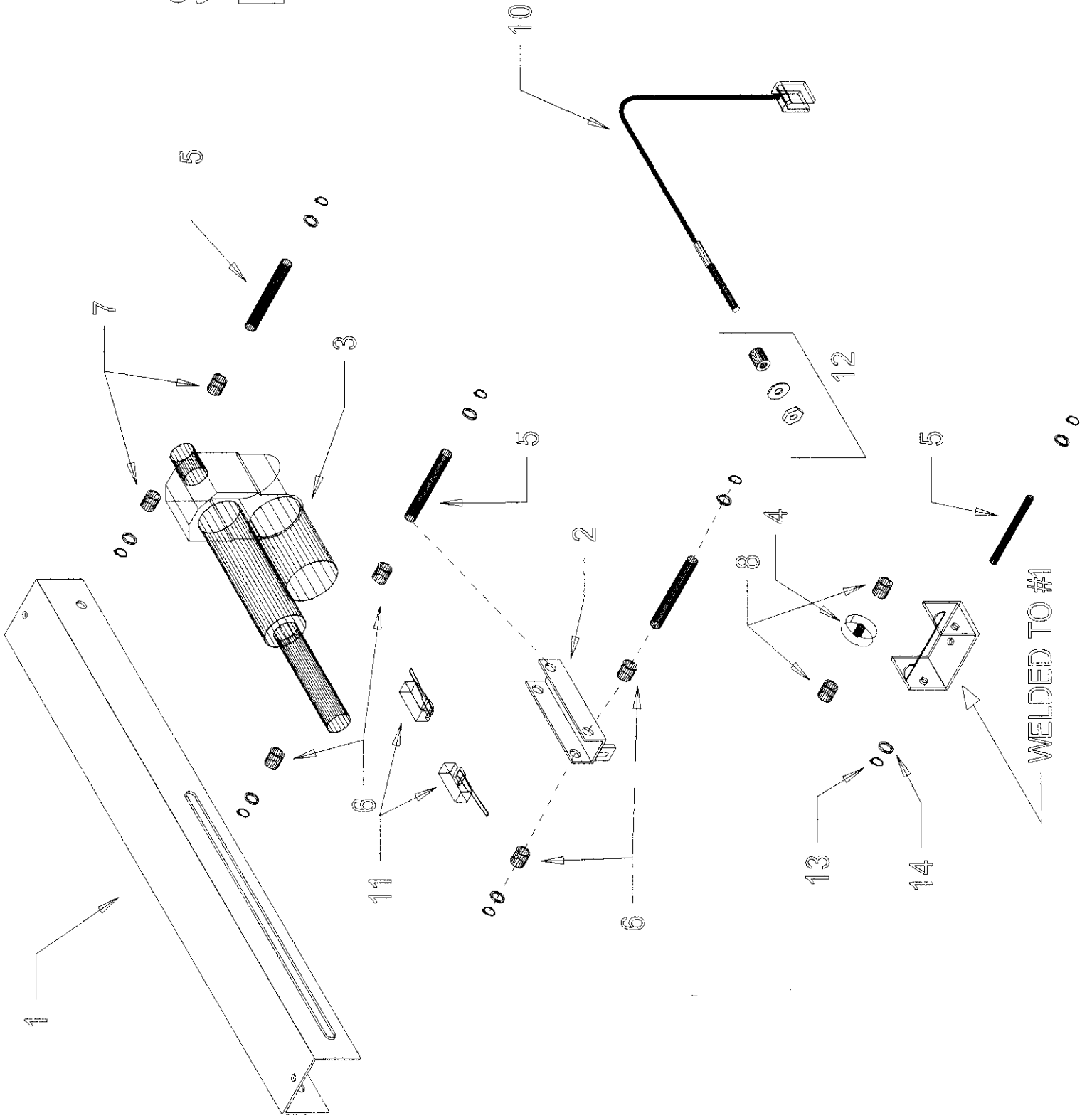

| Reference | DESCRIPTION | Part No. | Qty Req'd. |
|-----------------------------|---------------------------------------------------------------------|----------|------------|
| SQUEEGEE LIFT SYSTEM | | | |
| 1 | Channel, squeegee lift | 5-766 | 1 |
| 2 | Squeegee Lift Carriage | 5-771 | 1 |
| 3 | Squeegee Lift Actuator | 5-224 | 1 |
| 4 | Pulley, nylon | 5-772 | 1 |
| 5 | Pin, squeegee lift | 5-773 | 4 |
| 6 | Bushing, squeegee actuator .844" | 5-774 | 4 |
| 7 | Bushing, squeegee actuator 1.03" | 5-775 | 2 |
| 8 | Bushing, cable pulley, 1.36" | 5-776 | 2 |
| 10 | Squeegee Lift Cable (Includes item 12 below) | 5-769 | 1 |
| 11 | Lift Limit Switch | 5-223 | 2 |
| 12 | Polymmer Spring w/ Washer and Nuts (comes with squeegee lift cable) | 5-769A | 1 |
| 13 | Pin Retaining Snap Ring | 8-740 | 8 |
| 14 | Nylon Washer | H-76065 | 8 |

SQUEEGEE & SUSPENSION

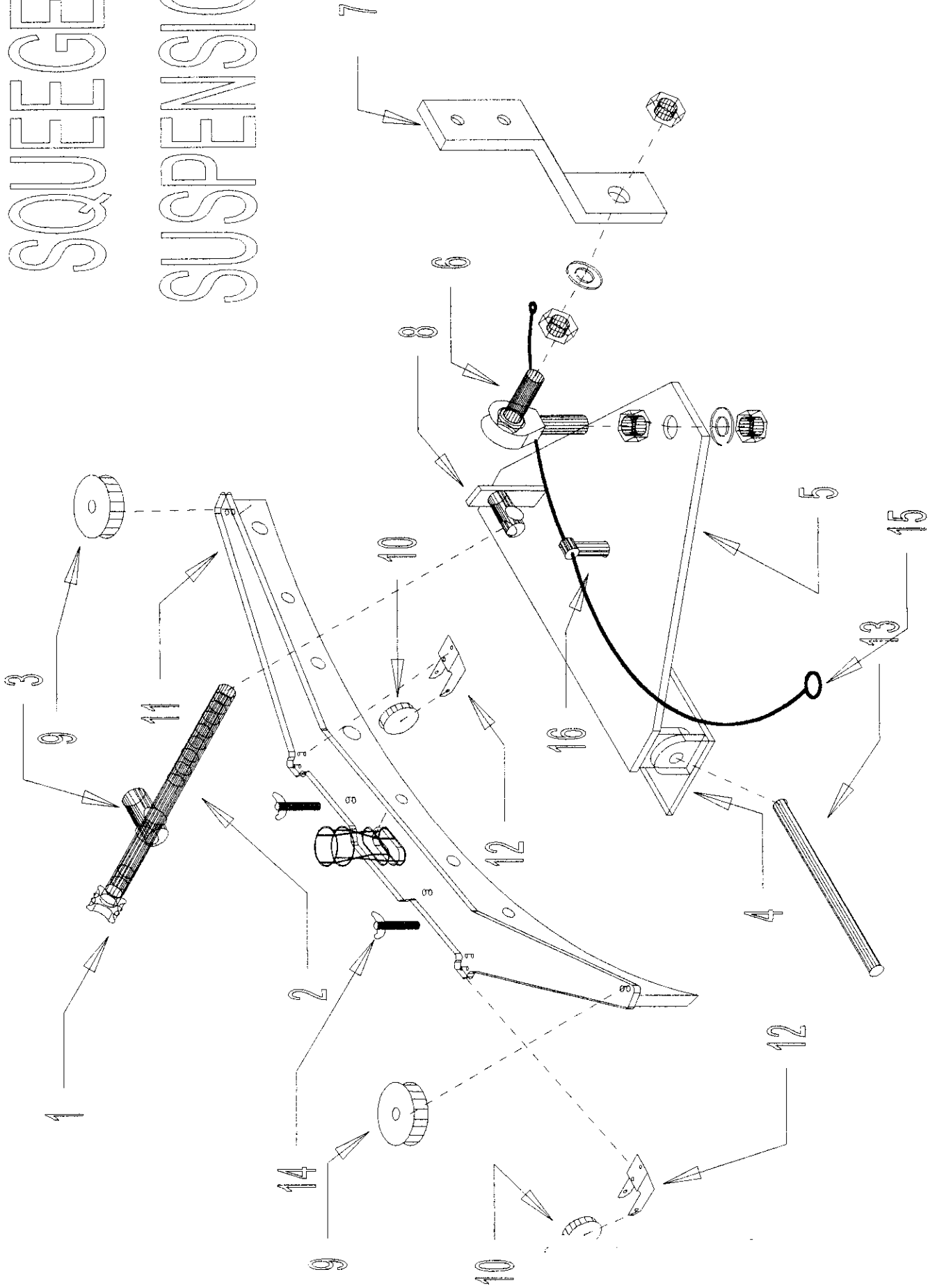

| Reference | DESCRIPTION | Part No. | Qty Req'd. |
|-----------|---------------------------------------------------------------------------------|----------|-------------|
| | <u>SQUEEGEE AND SQUEEGEE SUSPENSION SYSTEM:</u> | | |
| | <u>SQUEEGEE WEAR & REBUILD PARTS (40 & 40 HD are Different!)</u> | | |
| | <u>For Model 40:</u> | | |
| | Kit for Model 40 (Includes 1 front & 2 rear blades and 2 wheels) Gum rubber | 7-790G | |
| | Kit for Model 40 (Includes 1 front & 2 rear blades and 2 wheels) Neoprene | 7-790N | |
| | Front Squeegee Blade Mounting Strap (not shown) for Model 40 | 7-772 | |
| | Rear Squeegee Mounting Strap w/Latch (not shown) for 40 | 7-774 | |
| | <u>For Model 40 HD:</u> | | |
| | Kit for Model 40HD (Includes 1 front & 2 rear blades and 2 wheels) Gum rubber | 5-770G | |
| | Kit for Model 40HD (Includes 1 front & 2 rear blades and 2 wheels) Neoprene | 5-770N | |
| | Front Squeegee Blade Mounting Strap (not shown) for Model 40 HD | 5-756 | 2 |
| | Rear Squeegee Mounting Strap w/Latch (not shown) for 40 HD | 5-753 | 1 |
| 1 | Squeegee Pitch Adjusting Knob | 5-761 | 1 |
| 2 | Squeegee Angle Adjustment Rod | 5-762 | 1 |
| 3 | Squeegee Pivot Lug: not threaded | 5-778 | 1 |
| 4 | Squeegee Pitch Angle Adjustment Plate | 5-763 | 1 |
| 5 | Squeegee Triangle Plate | 5-764 | 1 |
| 6 | Squeegee Ball-Joint | 5-768 | 1 |
| 7 | Squeegee Hitch (on units built before 4/2000) W/Multispeed transaxle | 5-767 | 1 |
| | Squeegee Hitch (4/2000 and after) | 5-3101 | 1 |
| 8 | Squeegee Pivot Lug: threaded | 5-779 | 1 |
| 9 | Wall Rolling Wheels (with axle and washer) | 5-760 | 1 Set of 2 |
| 10 | Squeegee Wheels including axles and lockpins | 5-757 | 1 Set of 2 |
| 11 | Squeegee Body Model 40 | 7-758 | 1 for 40 |
| | Squeegee Body Model 40 HD | 5-759 | 1 for 40 HD |
| 12 | Squeegee Wheel Mounting Brackets | 5-758 | 2 |
| 13 | Squeegee Pivot Rod | 5-765 | 1 |
| 14 | Old Style Squeegee Hold Down System | 5-780 | 1 |
| | Belleville Washer | NSS | 2 |
| | Wingbolt | NSS | 2 |
| | Buno-O Ring | NSS | 2 |
| | NSS | NSS | |
| | <u>New Style Squeegee Hold Down System uses following parts:</u> | | |
| | Rubber Mounting Pad | 5-751 | 1 |
| | Wing Nut | 5-786 | 2 |

SQUEEGER & SUSPENSION

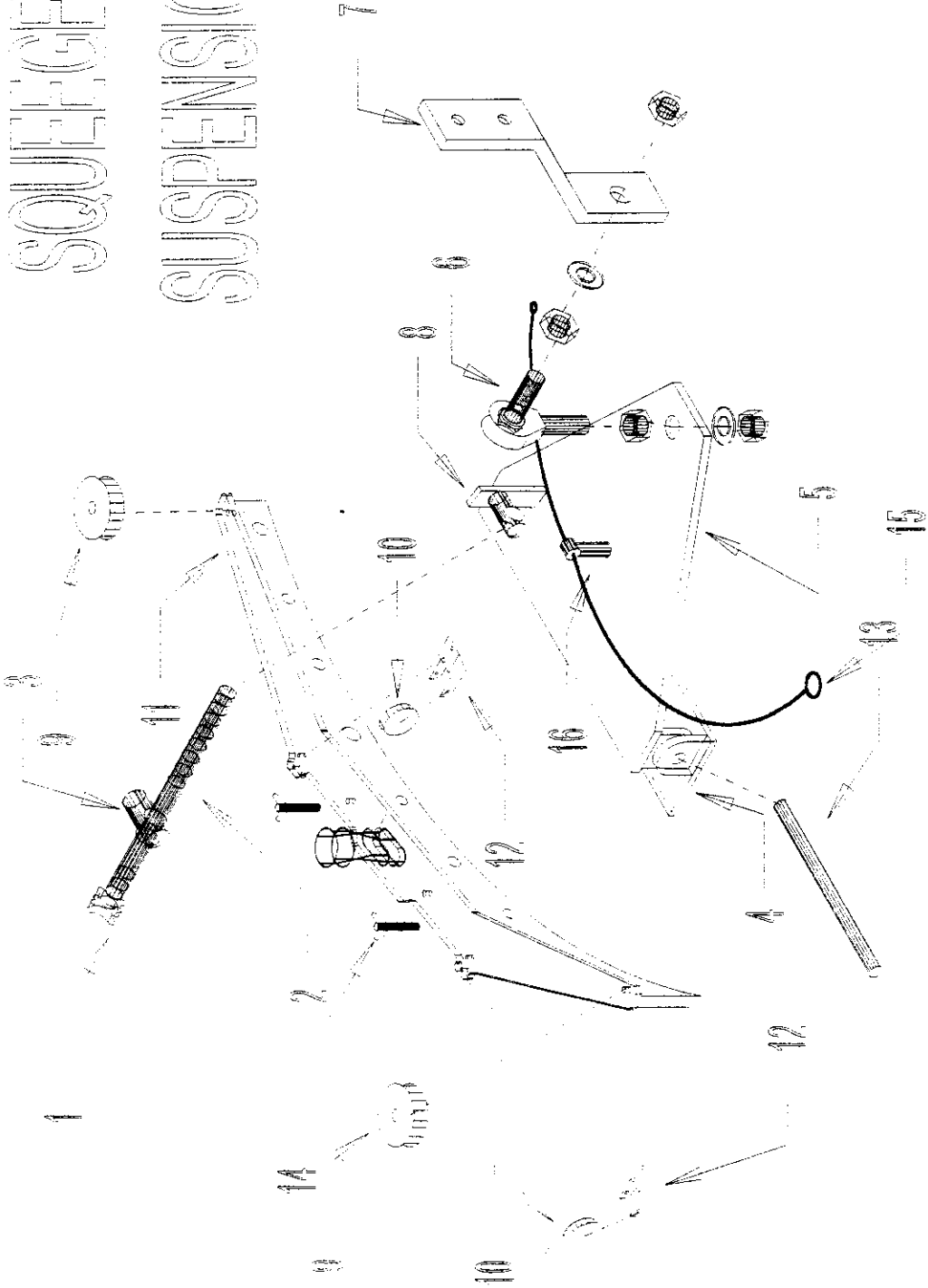

| | | | |
|----------------|--------------------------------------------------------------------------------|---------|---|
| | 3/8-16 Stud (Loktited into squeegee back) | H-95412 | 2 |
| 15 | Squeegee Swing Limit Cable W/Stop Collars & eyebolt (Before 4/2000: old trans) | 5-790 | 1 |
| | Squeegee Swing Limit Cable W/Stop Collars (Units after 4/2000: new trans) | 5-7900 | 1 |
| See Trans Page | Squeegee Limit Cable Mounting Clamp (New trans Units 1/2000 thru 3/2000 only) | 5-3106 | 2 |
| See Trans Page | Squeegee Limitation Cable Mounting Clamp (New trans Units after 4/2000 only) | 5-3104 | 2 |
| 16 | Squeegee Limitation Cable Eyebolt (Fits all) | 5-792 | 1 |

STEERING COLUMN

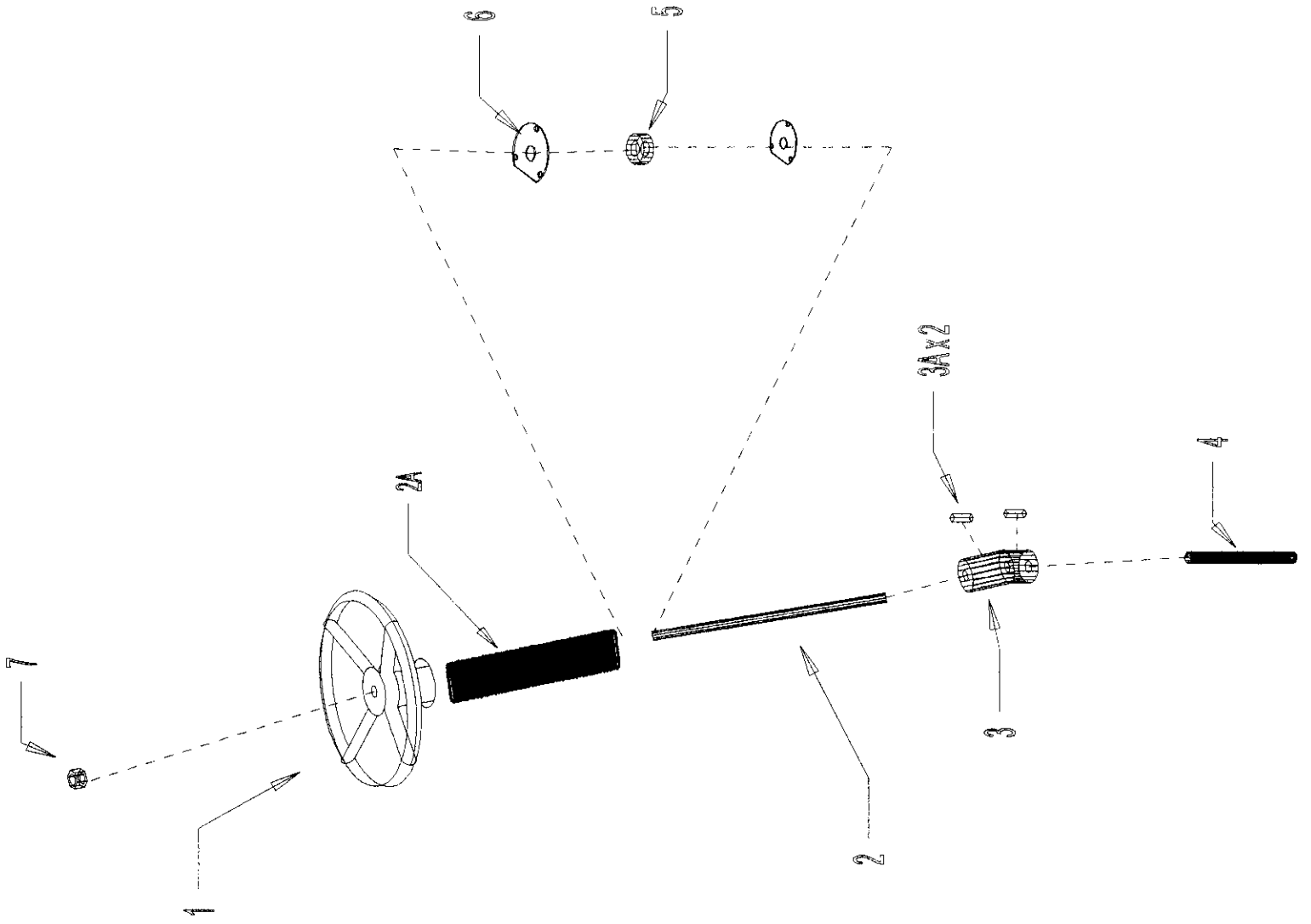

| Reference | DESCRIPTION | Part No. | Qty Req'd. |
|------------------------|-----------------------------------------|----------|------------|
| STEERING COLUMN | | | |
| 1 | Steering Wheel | 8-701 | 1 |
| 2 | Steering Upper Shaft | 8-710 | 1 |
| 2A | Steering Column Cover (black plastic) | 8-710A | 1 |
| 3 | Steering Universal Joint | 8-711 | 1 |
| 3A | Steering Shaft Key | 4-357 | 2 |
| 4 | Steering Lower Shaft | 8-712 | 1 |
| 5 | Bearing: upper steering | 4-352 | 1 |
| 6 | Bearing Mount Flange (set of 2 flanges) | 4-364 | 1 set of 2 |
| 7 | Steering Wheel Nut | 8-735 | 1 |

STEERING YOKE ASSEMBLY

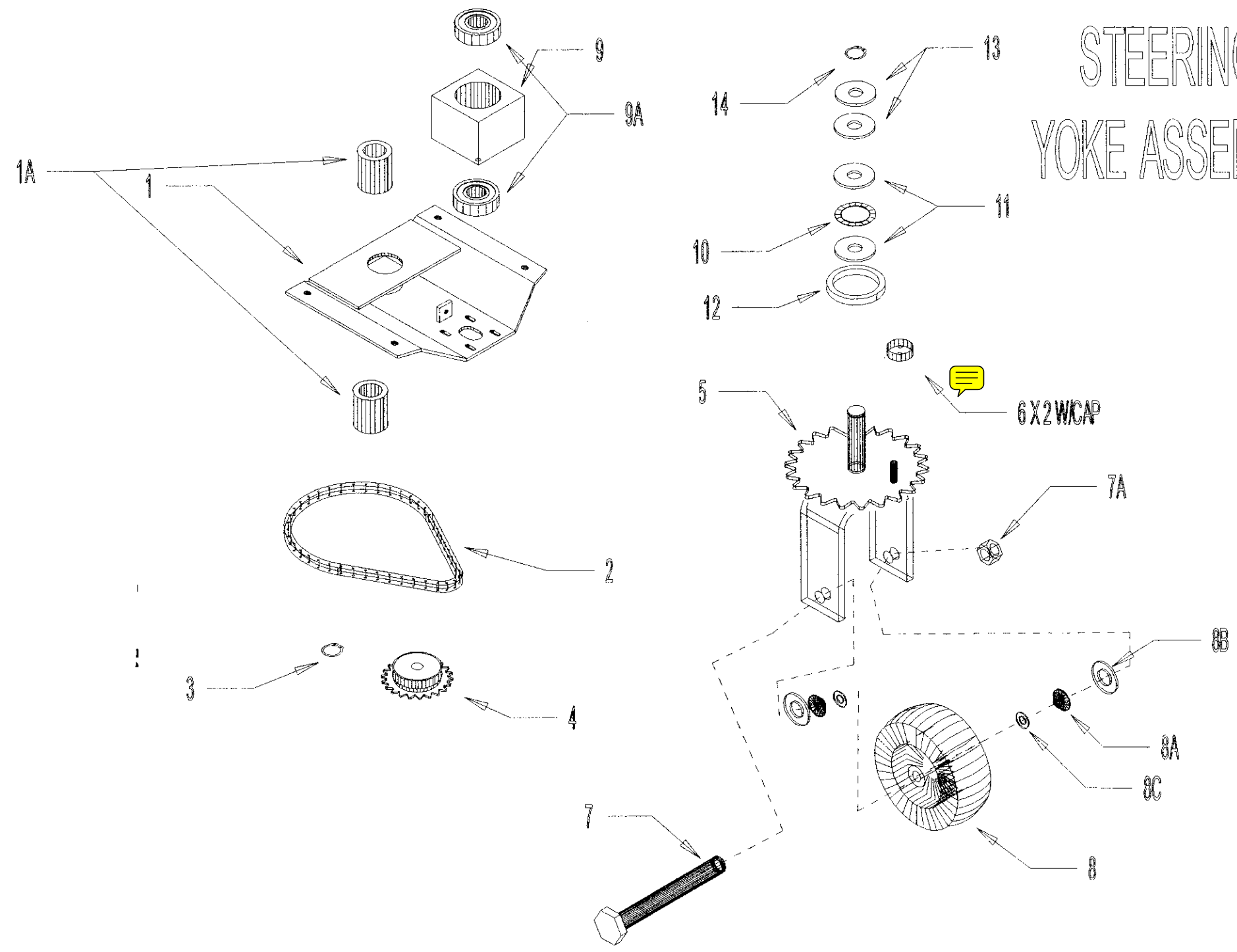

| Reference | DESCRIPTION | Part No. | Qty Req'd. |
|----------------------|------------------------------------------------------------------|----------|------------|
| STEERING YOKE | | | |
| 1 | Yoke Bearing Plate (with bearing set) | 8-720 | 1 |
| | Yoke Bearing Plate (no bearing set) | 8-720A | 1 |
| 1A | Yoke Plate Bearing Set (installation requires pressing-in) | 8-726 | 1 |
| 2 | Steering Chain including master link | 8-721 | 1 |
| 3 | Steering Yoke Retaining Snap Ring 5/8" | H-68013 | 1 |
| 4 | Steering Small Sprocket (has 9 teeth) | 8-722 | 1 |
| 5 | Steering Yoke and Big Sprocket Assembly | 8-730 | 1 |
| 6 | Steering Stop Grommet | 4-446 | 2 |
| 6A | Cap (not shown) | 4-510 | 1 |
| 7 | Wheel Axle | 8-734 | 1 |
| 7A | Wheel Axle Nut | 8-733 | 1 |
| 8 | Front Wheel with special "P-7" tire inc. bearings, seal & washer | 5-731 | 1 |
| | Optional Grey non marking wheel and tire set | 8-702 | 1 Opt |
| 8A | | 8-736A | 2 |
| 8B | | 8-737 | 2 |
| 8C | | 5-738 | 2 |
| 9 | Wheel Bearing Thrust Tube | 8-723A | 1 |
| | Steering Bearing Block: with bearings included | 8-723B | 2 |
| 9A | Steering Block Bearings | 8-714 | 1 |
| 10 | Steering Yoke/Sprocket Roller bearing | 8-713 | 1 set of 2 |
| 11 | Thrust Washer Set (for above bearing) Set of 2. | 8-715 | 1 |
| 12 | O Ring | 7-355 | 1 set of 4 |
| 13 | Space Washer Set (set of 4) | H-68019 | 1 |
| 14 | Snap Ring | | |

TRACTION SYSTEM

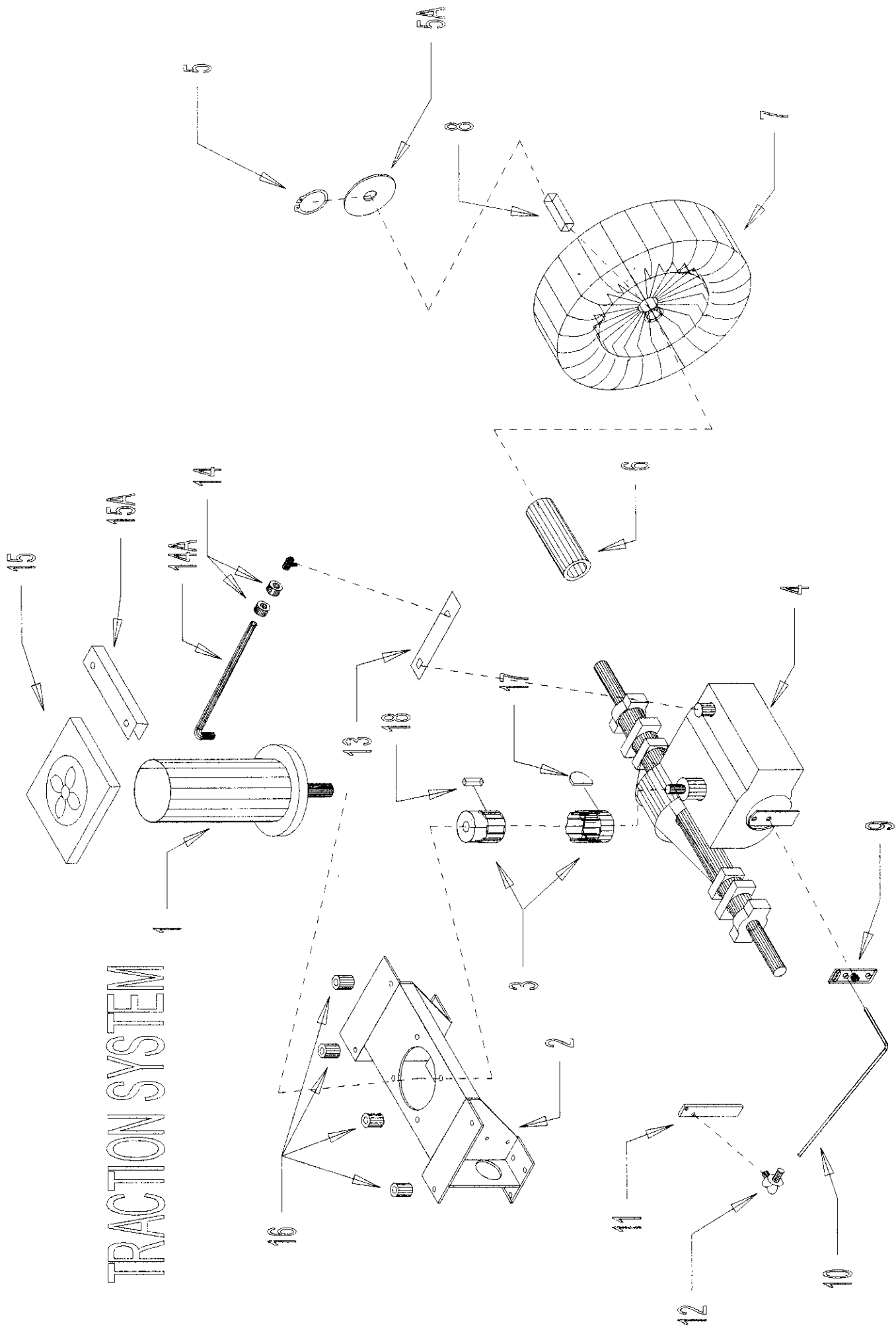

| Reference | DESCRIPTION | Part No. | Qty Req'd. |
|-------------------------------------------------------------------------|--------------------------------------------------|----------|------------|
| TRACTION SYSTEM: Units built Prior to 4/2000 | | | |
| <i>Note that Model 40HD with tall tanks used new system from 1/2000</i> | | | |
| <i>Note that Kit 113 allows retrofitting new transaxle to old units</i> | | | |
| 1 | Traction Motor (See also Electrical Page) | 8-211 | 1 |
| 2 | Traction Motor Cradle | 8-602 | 1 |
| 3 | Coupling, Motor to Transaxle (replaces pn 8-603) | 8-613 | 1 |
| Not Illustrated | Coupling Neoprene Center Spacer | 8-612S | 1 |
| 4 | Transaxle, New | 8-604 | 1 |
| | Transaxle, Rebuilt | 8-604R | 1 |
| 5 | Snap Ring | 8-611 | 1 |
| 5A | Washer | 7-355 | 2 |
| 6 | Stop Collar | 8-614 | 2 |
| 7 | Wheel, foam filled tire | 5-617 | 2 |
| 8 | Axle key 1/4 X 1/4 | 8-625 | 2 |
| 9 | Brake Lever Extension | 8-630 | 1 |
| 10 | Brake Release Extension Rod | 8-631 | 1 |
| 11 | Brake Release Lever | 8-632 | 1 |
| 12 | Treaded end fitting and link | 8-453A | 1 |
| 13 | Transaxle Shift Lever | 5-630 | 1 |
| 14 | Transaxle Shift Lever Limiting Collar | 5-631 | 2 |
| 14A | Transaxle Shift Lever Link | 5-632 | 1 |
| 15 | Traction Motor's Supplemental Cooling Fan | 5-212 | 1 |
| 15A | Transmission Cooling Fan Bracket | 5-213 | 1 |
| 16 | Transmission Cradle Mounting Spacer | 8-618 | 4 |
| 17 | Transmission Coupling Key (Half-Moon Shape) | 8-627 | 1 |
| 18 | Motor Coupling Key (3/16 X 3/16 X 3/4" long) | H-00270 | 1 |

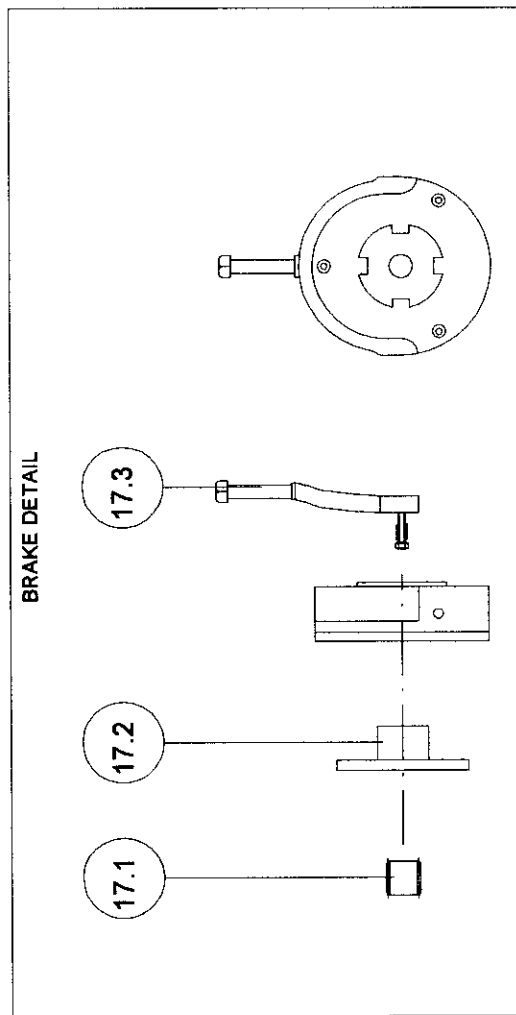
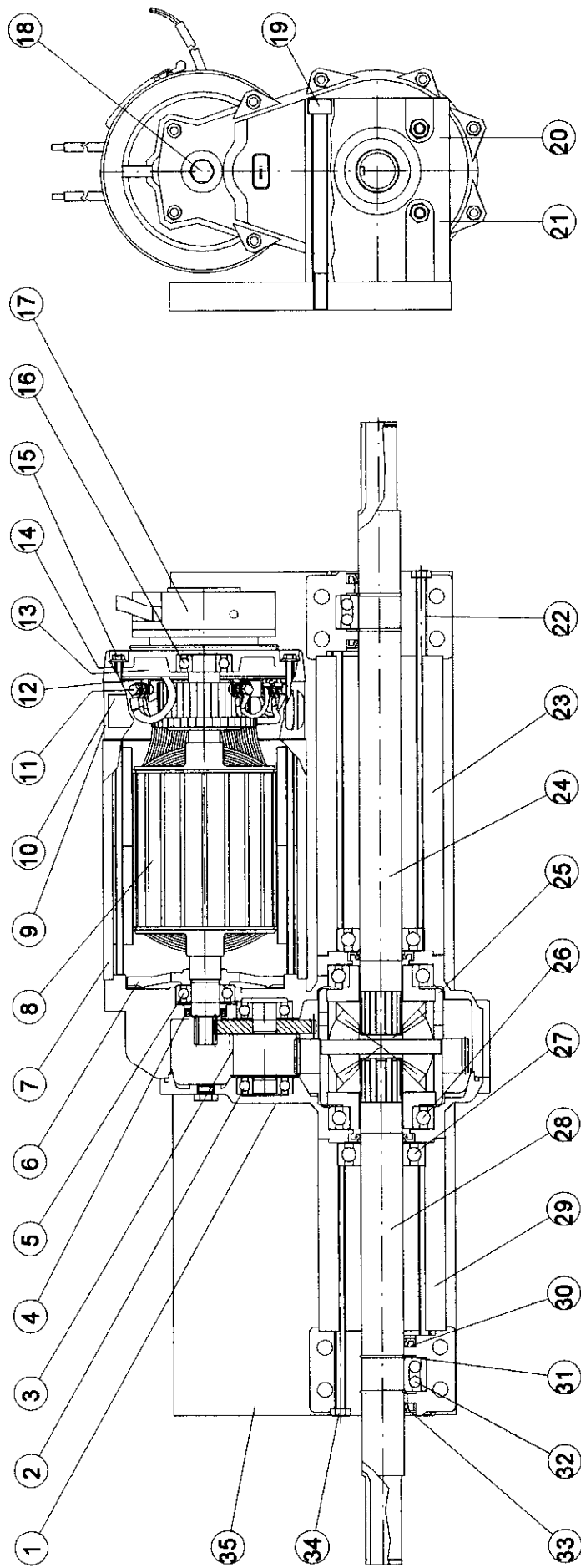

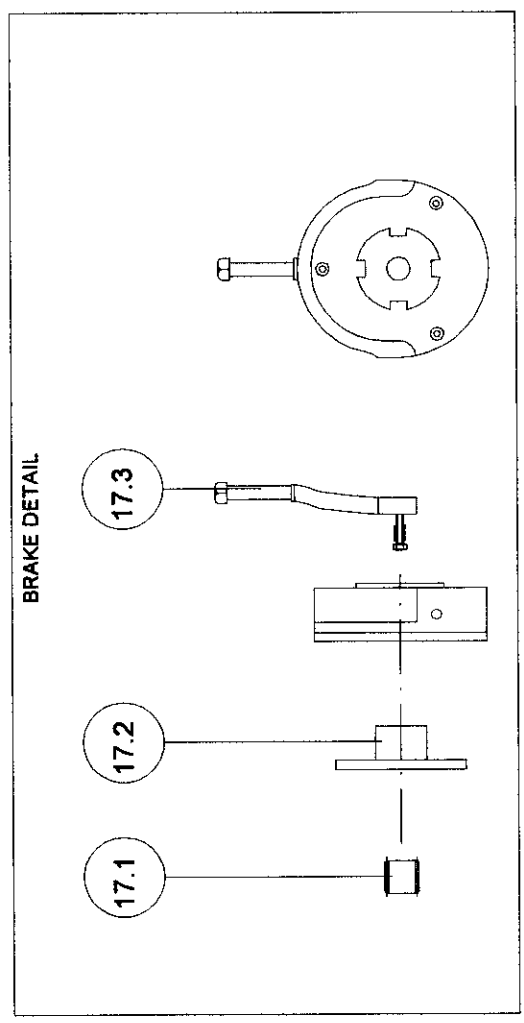
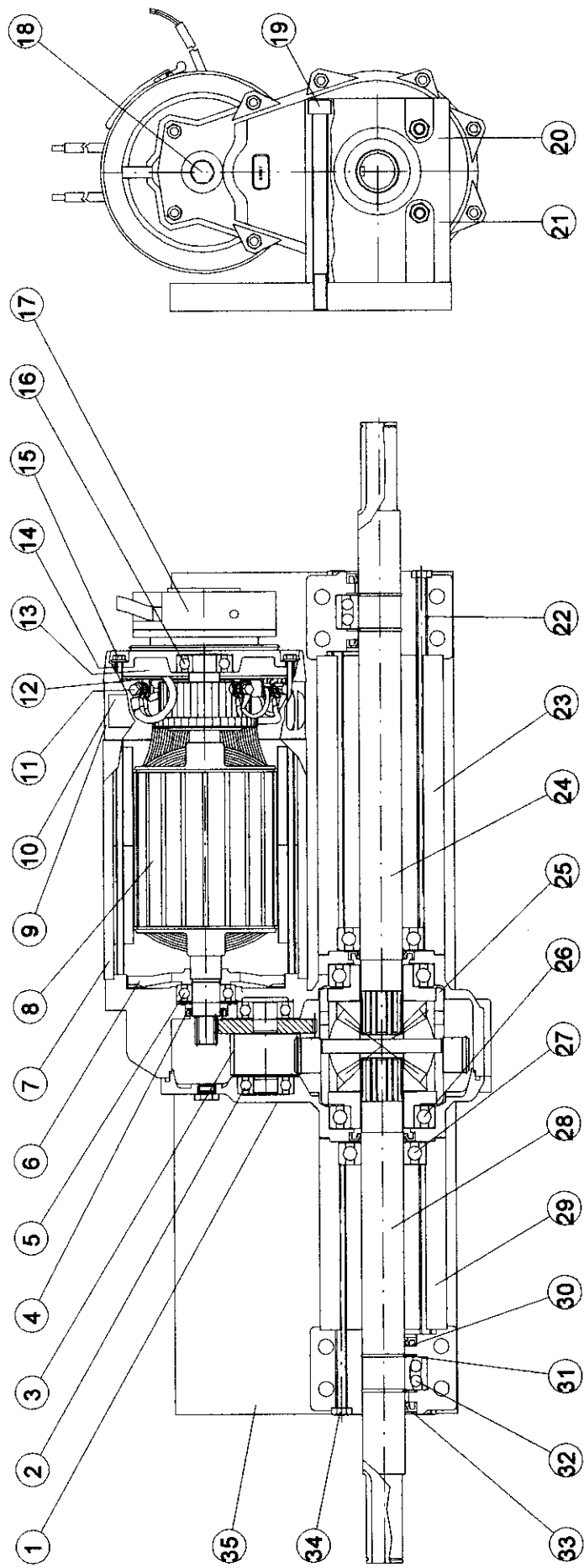

TRANSAXLE PARTS

Note: This Motor/Axle Unit fitted to standard units after 4/1/2000

Also mounted on 70 Gallon tank version of HD units after 1/1/2000

| Reference | DESCRIPTION | PART No. | Qty Req'd |
|-----------------|------------------------------------------------------|----------|-----------|
| 25 | Differential assembly, complete | 5-939 | 1 |
| 26 | Differential bearing | 5-954 | 2 |
| 27 | Bearing single race ball (inside) | 5-941 | 2 |
| 28 | Axle shaft righthand (short side) | 5-942 | 1 |
| 29 | Righthand axle housing tube (short side) | 5-943 | 1 |
| 30 | Inside bearing bracket seal | 5-955 | 4 |
| 31 | Shaft stop ring (set of 4) | 5-971 | 1 |
| 32 | Bearing double race ball (outside) | 5-945 | 2 |
| 33 | Outside bearing bracket seal | 5-957 | 2 |
| 34 | Axle thrubolt righthand (short side) | 5-948 | 4 |
| 35 | Heavy steel back plate | 5-949 | 1 |
| Not illustrated | Oil: Use FINA Giran 220 or equivalent 90 Wt Gearlube | 5-950 | 1.5 lbs |

RECYCLING SYSTEM

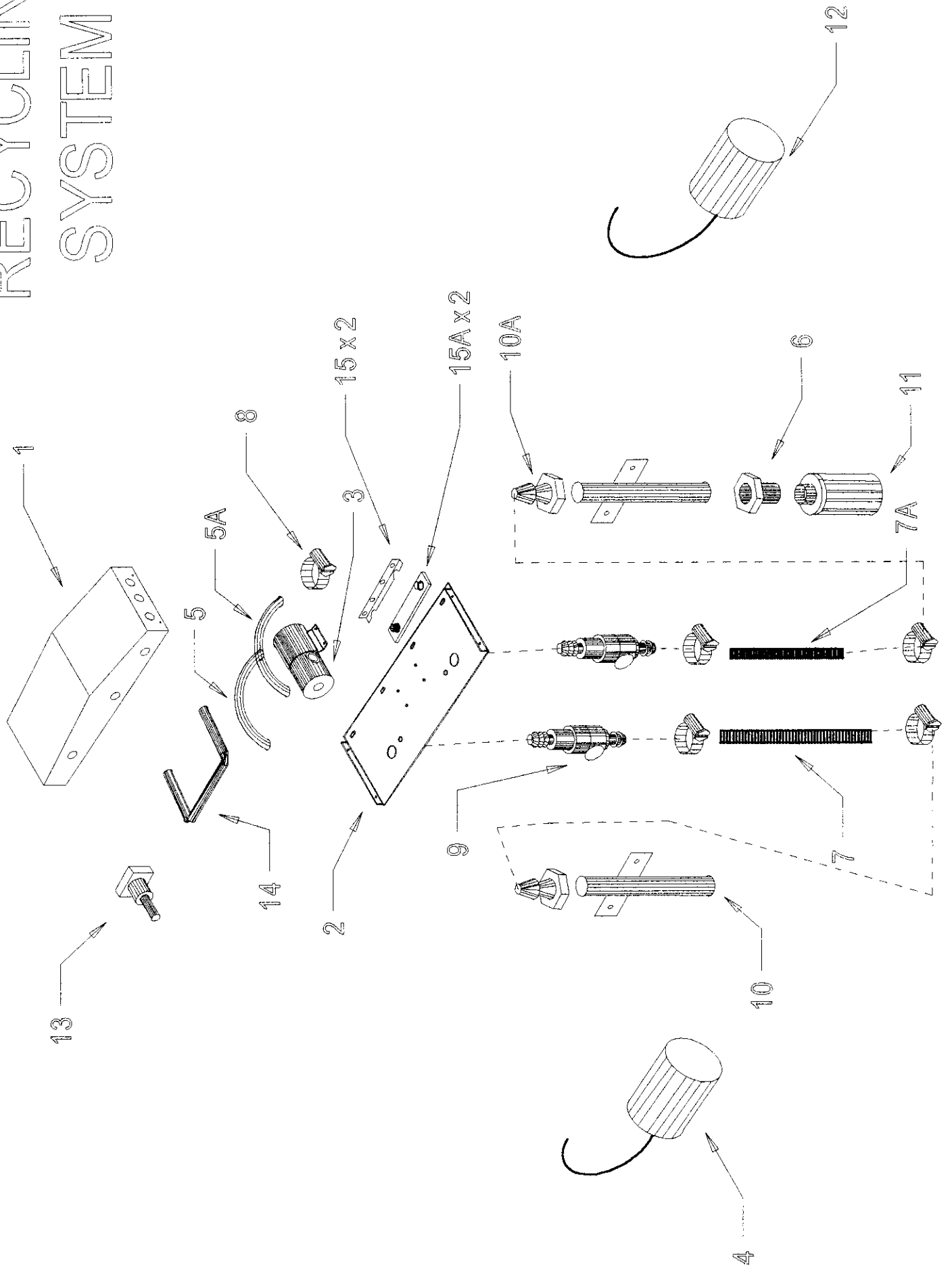

| Reference | DESCRIPTION | Part No. | Qty Req'd. |
|-------------------------|----------------------------------------------------------------|----------|------------|
| RECYCLING SYSTEM | | | |
| | <i>Recycling System is Optional--Not Found on all Machines</i> | | |
| | <i>Complete System--Sold as Field Installation Kit</i> | | |
| 1 | Cover | 5-850 | 1 (Opt) |
| 2 | Base | 5-852 | 1 |
| 3 | Pump | 5-851 | 1 |
| 4 | Recovery Shutoff Switch (Shuts off when tank level is low) | 5-870 | 1 |
| 5 | Hose: Solution Tank to Pump | 5-227 | 1 |
| 5A | Hose: Pump to Recovery Tank | 5-855 | 1 |
| 6 | Bushing (1/2 to 3/4) | 5-855A | 1 |
| 7 | Hose: 1/2" Solution Tank to Quick Disconnect | 5-862 | 1 |
| 7A | Hose: 1/2" Recovery Tank to Quick Disconnect | 5-856 | 1 |
| 8 | Clamp | 5-857 | 1 |
| 9 | Quick Disconnect | 5-848 | 10 |
| 10 | Stainless Tube | 5-859 | 2 |
| 11 | Recovery Filter | 5-860 | 2 |
| 12 | Solution Shutoff Switch (Shuts off when tank level is high) | 5-861 | 1 |
| 13 | On-Off Toggle Switch | 5-854 | 1 |
| Not Illustrated | Protective Rubber Boot for Switch | 5-892 | 1 |
| 14 | Handle--with mounting hardware | 5-892A | 1 |
| 15 | Hinge | 5-864 | 1 |
| 15A | Hinge Mount | 5-413 | 2 |
| Not Illustrated | On/Off Decal | 5-868 | 2 |
| Not Illustrated | Loop Clamp, 5/16" | 5-163 | 1 |
| | | 5-863 | 2 |

REMOVABLE BATTERY BOX

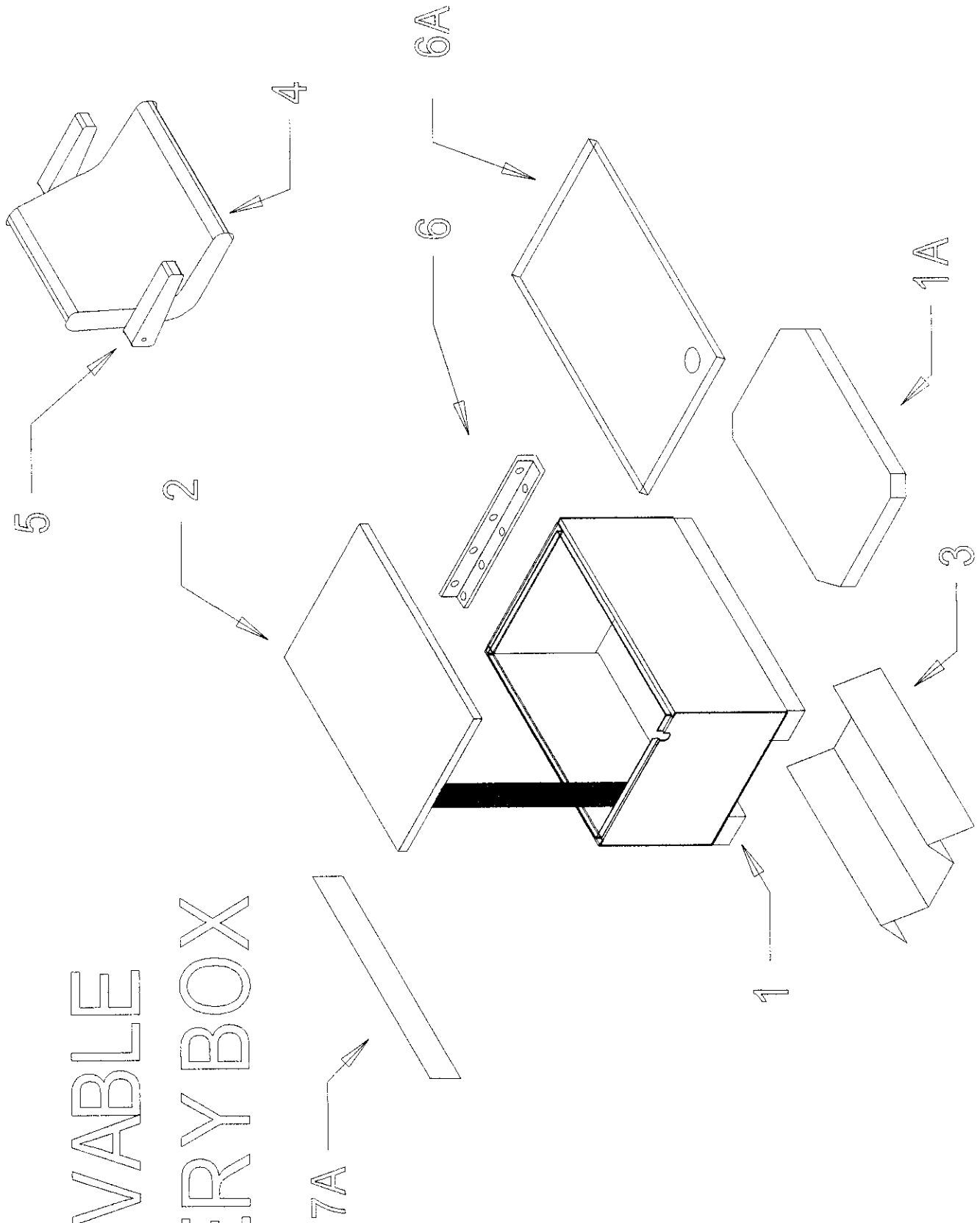

| Reference | DESCRIPTION | Part No. | Qty Req'd. |
|------------------------|-------------------------------------------------------------------------|----------|------------|
| | REMOVABLE BATTERY BOX SYSTEM | | |
| | <i>The Removable Battery Box System is Optional.</i> | | |
| 1 | Removable Battery Box (with fork tubes) | 5-160 | 1 |
| <i>Not Illustrated</i> | Plywood battery underlayment | 5-138 | 1 |
| 2 | Battery Box Lid | 5-146 | 1 |
| 3 | Battery Box Positioner. (Bolts to frame of machine) | 5-148 | 1 |
| 4 | Seat Sliding | 8-142 | 1 |
| 5 | Armrest Kit | 8-143A | 1 Set |
| 6 | Hinge | 5-128 | 1 |
| 6A | Battery Tray (black plastic) | 5-134 | 1 |
| 7A | Anti abrasion rubber strip to protect tanks. (Order 3 feet of material) | 4-112B | 1 |
| 8 | Polypropylene lid strap | 5-133 | 1 |
| <i>Not Illustrated</i> | Wiring Harness for Battery Set, Marine Terminal Style, Complete | 5-252N | 1 |
| <i>Not Illustrated</i> | Battery, 185 AH, 12 Volt | 4-271 | 4 or 6 |
| <i>Not Illustrated</i> | Battery, 205 AH, 12 Volt | 2-271 | 6 (Opt) |

VAC WAND & WATER JET SYSTEM

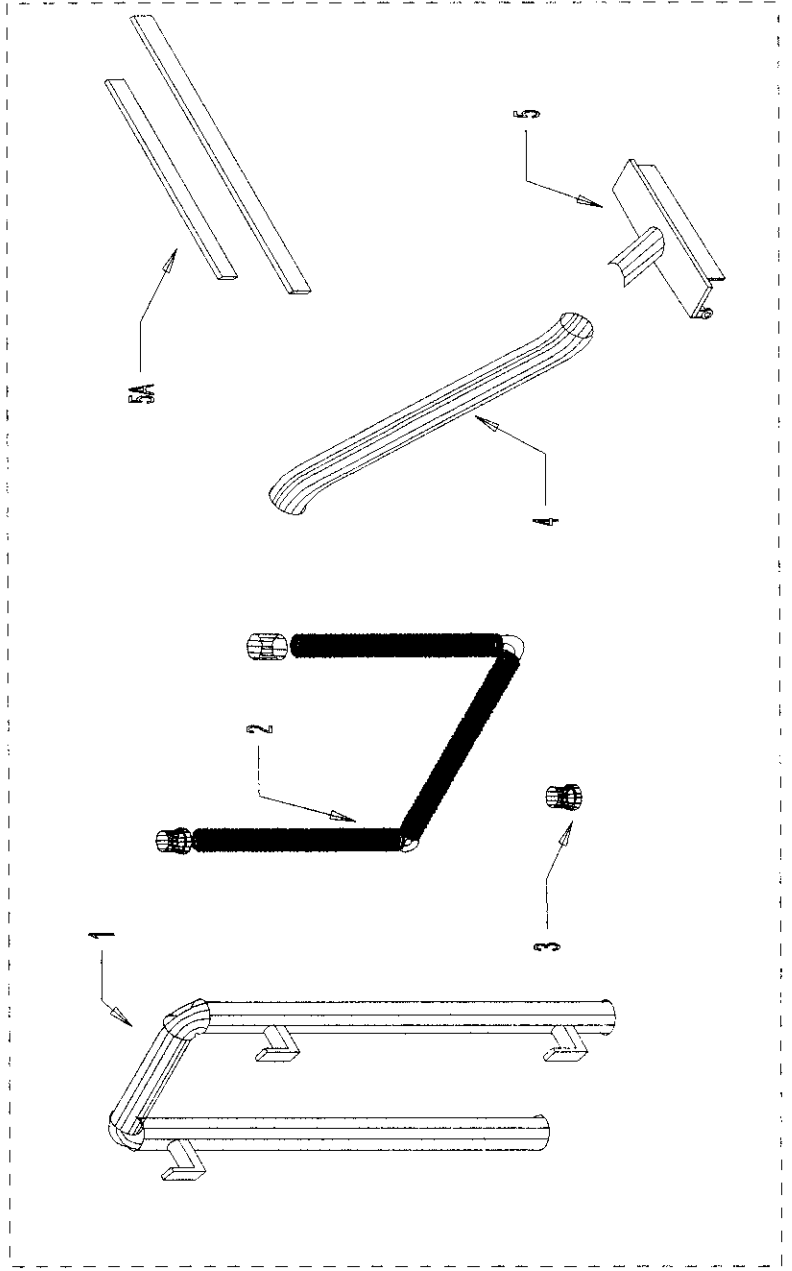
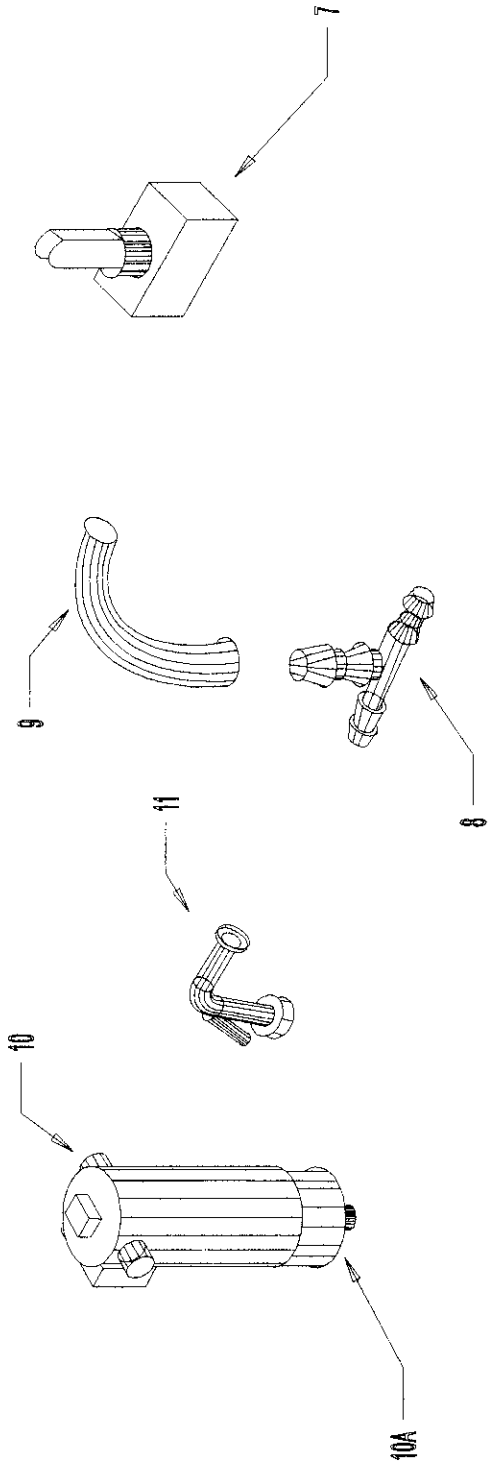

| Reference | DESCRIPTION | Part No. | Qty Req'd. |
|-----------------|-------------------------------------------------------------------------------------------------------------------------|----------------|--------------|
| | VAC WAND AND SPRAY JET SYSTEMS | | |
| | VAC WAND SYSTEM | | |
| 0 | COMPLETE WANDER HOSE FIELD KIT <i>Includes all of following items, plus installation instructions.</i> | 5-880 | 1 |
| 1 | Mounting Rack, <i>Includes Mounting Hardware</i> <i>Note: Mounting rack also used with Spray-Jet only systems</i> | 5-881 | 1 |
| 2 | Vacuum Hose <i>15 Feet long, 1.5" Dia., Includes Cuffs</i> | 5-886 5-883 | 2 1 |
| 4 | Wand Tube, Curved 54" | 5-884 7-710 | 1 1 |
| 5 | Vacuum Nozzle | 5-887 | 1 |
| 5A | Vacuum Nozzle blade kit. <i>Kit includes 2 blades, side wheels and brush</i> | 5-889 5-890 | 1 1 |
| | WATER JET SYSTEM | | |
| 7 | On-Off Toggle Switch | 5-892 | 1 |
| Not Illustrated | Toggle Switch protective boot | 5-892A | 1 |
| 8 | 1/2" T-Barb | 5-446 | 1 |
| | 5/8" T-Barb | 7-247 | 1 |
| 9 | 5/8" Hose | 5-460 | Sold by foot |
| | 1/2" Hose | 5-440 | Sold by foot |
| 10 | Pump, 60 psi | 5-891 | 1 |
| 10A | Pump's Fan Shroud | 5-893 | 1 |
| 11 | Spray Nozzle | 5-895 | 1 |
| 12 | Black rubber hose (for spray nozzle) 15 feet long. | 5-896 | 1 |
| Not Illustrated | Mounting Plate for Pump (Units built after 4/2000) <i>On these units the pump mounts on squeegee's towbar</i> | 5-3102 | 1 |
| Not Illustrated | Pump wiring harness | 5-897 | 1 |
| Not Illustrated | Pump fitting 5/8" | 5-891B | 1 |
| Not Illustrated | Pump Fitting 1/2" | 5-891A | 1 |